



OPERATING INSTRUCTIONS

EN

Translation of the Original

PKR 36X | IKR 36X

Pirani/cold cathode gauge | Cold cathode gauge

Dear Customer,

Thank you for choosing a Pfeiffer Vacuum product. Your new gauge is designed to support you in your individual application with maximum performance and without malfunctions. The name Pfeiffer Vacuum stands for high-quality vacuum technology, a comprehensive and complete range of top-quality products and first-class service. From this extensive, practical experience we have gained a large volume of information that can contribute to efficient deployment and to your personal safety.

In the knowledge that our product must avoid consuming work output, we trust that our product can offer you a solution that supports you in the effective and trouble-free implementation of your individual application.

Please read these operating instructions before putting your product into operation for the first time. If you have any questions or suggestions, please feel free to contact info@pfeiffer-vacuum.de.

Further operating instructions from Pfeiffer Vacuum can be found in the [Download Center](#) on our website.

Disclaimer of liability

These operating instructions describe all models and variants of your product. Note that your product may not be equipped with all features described in this document. Pfeiffer Vacuum constantly adapts its products to the latest state of the art without prior notice. Please take into account that online operating instructions can deviate from the printed operating instructions supplied with your product.

Furthermore, Pfeiffer Vacuum assumes no responsibility or liability for damage resulting from the use of the product that contradicts its proper use or is explicitly defined as foreseeable misuse.

Copyright

This document is the intellectual property of Pfeiffer Vacuum and all contents of this document are protected by copyright. They may not be copied, altered, reproduced or published without the prior written permission of Pfeiffer Vacuum.

We reserve the right to make changes to the technical data and information in this document.

Table of contents

1	About this manual	7
1.1	Validity	7
	1.1.1 Applicable documents	7
	1.1.2 Variants	7
1.2	Target group	8
1.3	Conventions	8
	1.3.1 Instructions in the text	8
	1.3.2 Pictographs	9
	1.3.3 Stickers on the product	9
	1.3.4 Abbreviations	9
1.4	Trademark proof	10
2	Safety	11
2.1	General safety information	11
2.2	Safety instructions	11
2.3	Safety precautions	13
2.4	Limits of use of the product	14
2.5	Proper use	14
2.6	Foreseeable improper use	14
2.7	Responsibilities and warranty	14
2.8	Owner requirements	15
2.9	Personnel qualification	15
	2.9.1 Ensuring personnel qualification	15
	2.9.2 Personnel qualification for maintenance and repair	15
	2.9.3 Advanced training with Pfeiffer Vacuum	16
2.10	Operator requirements	16
3	Product description	17
3.1	Function	17
3.2	Switch and status display	17
3.3	Identifying the product	18
3.4	Scope of delivery	18
4	Transport and storage	19
4.1	Transporting the product	19
4.2	Storing the product	19
5	Installation	20
5.1	Establishing the vacuum connection	20
5.2	Electronic unit	21
5.3	Establishing the electric connection	23
6	Operation	25
6.1	Operating modes PKR	25
6.2	Converting the PKR measuring signal and pressure	26
6.3	Converting the IKR measuring signal and pressure	27
6.4	Determining effective pressure with calibration factors	27
6.5	Ignition delay	30
6.6	Contamination	30
7	Disassembly	32
8	Maintenance	34
8.1	Calibrating the PKR gauge	34
8.2	Maintaining the IKR gauge	35
8.3	Disassembling the gauge	35
8.4	Replacing the ignition aid	36

8.5	Cleaning of components	38
8.6	Gauge assembling	39
9	Malfunctions	41
9.1	Troubleshooting	41
9.2	Identifying errors at the measurement chamber	42
10	Shipping	43
11	Recycling and disposal	44
11.1	General disposal information	44
11.2	Dispose of gauges	44
12	Service solutions by Pfeiffer Vacuum	45
13	Spare parts	47
14	Accessories	48
14.1	Accessory information	48
14.2	Ordering accessories	48
15	Technical data and dimensions	49
15.1	General	49
15.2	Technical data	49
15.3	Dimensions	53
	ETL certification PKR	54
	ETL certification IKR	55
	Declaration of Conformity	56
	Declaration of Conformity	57

List of tables

Tbl. 1:	Applicable documents	7
Tbl. 2:	PKR variants low voltage	7
Tbl. 3:	PKR variants high current	7
Tbl. 4:	IKR variants low voltage	8
Tbl. 5:	IKR variants high current	8
Tbl. 6:	Abbreviations used	10
Tbl. 7:	Permissible ambient conditions	14
Tbl. 8:	Illuminating diodes PKR	17
Tbl. 9:	Illuminating diodes IKR	18
Tbl. 10:	Operating modes PKR	25
Tbl. 11:	Constants for converting measuring signal and pressure	26
Tbl. 12:	Constants for converting measuring signal and pressure	27
Tbl. 13:	Calibration factors for the pressure range < 10 hPa PKR and IKR	29
Tbl. 14:	Calibration factors for the pressure range 0.02 hPa < p < 1 hPa in Pirani operation only PKR	30
Tbl. 15:	Malfunctions PKR	41
Tbl. 16:	Malfunctions IKR	42
Tbl. 17:	Measurement PKR	42
Tbl. 18:	Measurement IKR	42
Tbl. 19:	Spare parts	47
Tbl. 20:	Conversion table: Pressure units	49
Tbl. 21:	Conversion table: Units for gas throughput	49
Tbl. 22:	Measuring and pressure values PKR	49
Tbl. 23:	Measuring and pressure values IKR	49
Tbl. 24:	Electrical data PKR	50
Tbl. 25:	Electrical data IKR	51
Tbl. 26:	Internal volume and weight	51
Tbl. 27:	Ambient conditions	52
Tbl. 28:	Temperatures	52
Tbl. 29:	Substances in contact with the media	52

List of figures

Fig. 1:	PKR measuring configuration	17
Fig. 2:	Switch and LED	17
Fig. 3:	Establishing the vacuum connection	21
Fig. 4:	Electronic unit	22
Fig. 5:	Connection diagram	23
Fig. 6:	Measurement cable and Hirschmann cable socket	24
Fig. 7:	Relation between measuring signal and pressure	26
Fig. 8:	Relation between measuring signal and pressure	27
Fig. 9:	Pressure range > 10 hPa exclusively with Pirani operation PKR	28
Fig. 10:	Pressure range from 10 to 0.1 hPa PKR	28
Fig. 11:	Displayed pressure IKR	29
Fig. 12:	Disassembling the gauge	33
Fig. 13:	Calibrating the PKR gauge	35
Fig. 14:	Disassembling the gauge	36
Fig. 15:	Removing the ignition aid	37
Fig. 16:	Inserting the ignition aid in the mounting tool	37
Fig. 17:	Inserting the ignition aid	37
Fig. 18:	Switch for CAL calibration value	39
Fig. 19:	Gauge assembling	40
Fig. 20:	Contact pins of the measurement chamber	42
Fig. 21:	Complete measurement chamber (replacement sensor)	47
Fig. 22:	Dimensions	53

1 About this manual



IMPORTANT

Read carefully before use.
Keep the manual for future consultation.

1.1 Validity

This document describes the function of the products listed in the following and provides the most important information for safe use. The description is written in accordance with the valid directives. The information in this document refers to the current development status of the products. The document retains its validity assuming that the customer does not make any changes to the product.

1.1.1 Applicable documents

Designation	Document
"Total Pressure Measuring and Control Unit" operating instructions TPG 361 TPG 362	BG 5500
"Total Pressure Measuring and Control Unit" operating instructions TPG 366	BG 5501
Declarations of Conformity	A component of these instructions

Tbl. 1: Applicable documents

You can find these documents in the [Pfeiffer Vacuum Download Center](#).

1.1.2 Variants

This document applies to products with the following article numbers:

Article number	Designation
PT T02 140 010	PKR 360, DN 25 ISO-KF
PT T02 140 011	PKR 360 C, DN 25 ISO-KF, ceramic coated
PT T02 150 010	PKR 360, DN 40 ISO-KF
PT T02 150 011	PKR 360 C, DN 40 ISO-KF, ceramic coated
PT T02 350 010	PKR 360, DN 40 CF-F
PT T02 350 011	PKR 360 C, DN 40 CF-F, ceramic coated

Tbl. 2: PKR variants low voltage

Article number	Designation
PT T03 140 010	PKR 361, DN 25 ISO-KF
PT T03 140 011	PKR 361 C, DN 25 ISO-KF, ceramic coated
PT T03 150 010	PKR 361, DN 40 ISO-KF
PT T03 150 011	PKR 361 C, DN 40 ISO-KF, ceramic coated
PT T03 350 010	PKR 361, DN 40 CF-F
PT T03 350 011	PKR 361 C, DN 40 CF-F, ceramic coated

Tbl. 3: PKR variants high current

Article number	Designation
PT T00 140 010	IKR 360, DN 25 ISO-KF
PT T00 140 011	IKR 360 C, DN 25 ISO-KF, ceramic coated

Article number	Designation
PT T00 150 010	IKR 360, DN 40 ISO-KF
PT T00 150 011	IKR 360 C, DN 40 ISO-KF, ceramic coated
PT T00 350 010	IKR 360, DN 40 CF-F
PT T00 350 011	IKR 360 C, DN 40 CF-F, ceramic coated

Tbl. 4: IKR variants low voltage

Article number	Designation
PT T01 140 010	IKR 361, DN 25 ISO-KF
PT T01 140 011	IKR 361 C, DN 25 ISO-KF, ceramic coated
PT T01 150 010	IKR 361, DN 40 ISO-KF
PT T01 150 011	IKR 361 C, DN 40 ISO-KF, ceramic coated
PT T01 350 010	IKR 361, DN 40 CF-F
PT T01 350 011	IKR 361 C, DN 40 CF-F, ceramic coated

Tbl. 5: IKR variants high current

You can find the part number on the rating plate of the product.

Pfeiffer Vacuum reserves the right to make technical changes without prior notification.

Information that relates to only one of the products is indicated accordingly.

The figures in this document are not to scale.

Graphics without a caption reflect the product featuring a DN 25 ISO-KF vacuum connection, however, they also apply for the other vacuum connections accordingly.

Dimensions are in mm unless stated otherwise.

1.2 Target group

These operating instructions are aimed at all persons performing the following activities on the product:

- Transportation
- Setup (Installation)
- Usage and operation
- Decommissioning
- Maintenance and cleaning
- Storage or disposal

The work described in this document is only permitted to be performed by persons with the appropriate technical qualifications (expert personnel) or who have received the relevant training from Pfeiffer Vacuum.

1.3 Conventions

1.3.1 Instructions in the text

Usage instructions in the document follow a general structure that is complete in itself. The required action is indicated by an individual step or multi-part action steps.

Individual action step

A horizontal, solid triangle indicates the only step in an action.

- ▶ This is an individual action step.

Sequence of multi-part action steps

The numerical list indicates an action with multiple necessary steps.

1. Step 1
2. Step 2
3. ...

1.3.2 Pictographs

The pictographs used in the document indicate useful information.



Note



Tip



Wear laboratory gloves



Perform a visual inspection

1.3.3 Stickers on the product

This section describes all the stickers on the product along with their meaning.

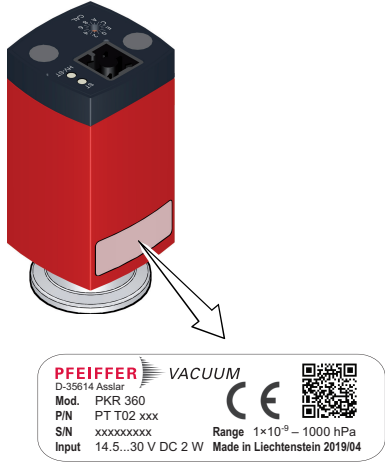
 <p>PFEIFFER VACUUM D-35614 Asslar Mod. PKR 360 P/N PT T02 xxx S/N xxxxxxxxx Input 14.5...30 V DC 2 W Range 1×10^{-9} – 1000 hPa Made in Liechtenstein 2019/04</p>	<p>Rating plate The rating plate is located on the back of the device.</p>
---	---

1.3.4 Abbreviations

Abbreviation	Explanation
ATM	Atmosphere
c	Constant for converting measuring signal and pressure
C	Calibration factor for calculating the pressure for gases other than air
d	Constant for converting measuring signal and pressure
GND	Ground
HV	High vacuum
cpl.	Complete unit
LED	Light emitting diode
LPS	Limited power source
MSL	Mean sea level
p	Pressure
PELV	Protective extra low voltage
s	seconds
WAF	Width Across Flats

Abbreviation	Explanation
U	Measuring signal [V] (output voltage)
VCR	Trademark of the Swagelok Company

Tbl. 6: Abbreviations used

1.4 Trademark proof

- FullRange® is a trademark of Pfeiffer Vacuum GmbH.
- Hirschmann® is a trademark of Hirschmann Electronics GmbH.
- Scotch-Brite® is a registered trade name of 3M Company.

2 Safety

2.1 General safety information

The following 4 risk levels and 1 information level are taken into account in this document.

DANGER

Immediately pending danger

Indicates an immediately pending danger that will result in death or serious injury if not observed.

- ▶ Instructions to avoid the danger situation

WARNING

Potential pending danger

Indicates a pending danger that could result in death or serious injury if not observed.

- ▶ Instructions to avoid the danger situation

CAUTION

Potential pending danger

Indicates a pending danger that could result in minor injuries if not observed.

- ▶ Instructions to avoid the danger situation

NOTICE

Danger of damage to property

Is used to highlight actions that are not associated with personal injury.

- ▶ Instructions to avoid damage to property



Notes, tips or examples indicate important information about the product or about this document.

2.2 Safety instructions



Safety instructions according to product life stages

All safety instructions in this document are based on the results of a risk assessment. Pfeiffer Vacuum has taken into account all the relevant life stages of the product.

Risks during installation

DANGER

Danger to life due to dangerous contact voltage

Voltages above 30 V (AC) or 60 V (DC) are considered dangerous in accordance with EN 61010. If you come into contact with dangerous contact voltage, this can result in injury through electric shocks or even death.

- ▶ Only connect the product to devices which meet the following criteria:
 - Requirements of the earthed protective extra-low voltage (PELV)
 - Limited power source (LPS) Class 2
- ▶ Secure the line to the product.
 - Pfeiffer Vacuum measuring and control equipment complies with this requirement.

⚠ DANGER

Risk to life due to electric shock

An improperly earthed product is potentially fatal in the event of a fault.

- ▶ Connect the product galvanically with the earthed vacuum chamber.
- ▶ Ensure that the connection complies with the requirements of a protective bonding according to EN 61010. (CF and VCR connections comply with this requirement.)
- ▶ Use electrically conductive centering rings and circlips for KF connections.

Risks during operation

⚠ WARNING

Risk of injury resulting from overpressure in the vacuum system

Opening tensioning pieces with an overpressure > 1000 hPa in the vacuum system can lead to injuries as a result of flying parts, and escaping process medium could prove harmful to health.

Elastomer seals in KF connections (e.g. O-rings) are not resistant to pressures > 2500 hPa. This could prove harmful to health due to escaping process medium.

- ▶ Do not open any tensioning pieces when overpressure is prevalent in the vacuum system.
- ▶ Use suitable tensioning pieces for overpressure.
- ▶ Use tensioning pieces which can only be opened and closed using a tool (e.g. tightening strap-circlip).
- ▶ Use sealing rings with an outer centering ring.

Risks during maintenance

⚠ DANGER

Risk to life due to electric shock

If no earth connection is established, voltage flows become hazardous to the touch and could lead to electronic components sustaining damage.

- ▶ Always tighten the electronic unit with the grub screw.
- ▶ Ensure that the grub screw of the electronic unit has been tightened correctly.

⚠ DANGER

Electric shock due to moisture entering the unit

Water that has entered the unit will result in personal injury through electric shocks.

- ▶ Only operate the unit in a dry environment.
- ▶ Operate the unit away from fluids and sources of moisture.
- ▶ Do not switch on the unit if fluid has entered it. Instead contact Pfeiffer Vacuum Service.
- ▶ Always disconnect the power supply before cleaning the unit.

⚠ WARNING

Health hazard through poisoning from toxic contaminated components or devices

Toxic process media result in contamination of devices or parts of them. During maintenance work, there is a risk to health from contact with these poisonous substances. Illegal disposal of toxic substances causes environmental damage.

- ▶ Take suitable safety precautions and prevent health hazards or environmental pollution by toxic process media.
- ▶ Decontaminate affected parts before carrying out maintenance work.
- ▶ Wear protective equipment.

⚠ WARNING**Health hazards due to cleaning agent**

The cleaning agent being used causes health hazards which could include, for example, poisoning, allergies, skin irritations, chemical burns or damage to the airways.

- ▶ When handling cleaning agents, observe the applicable regulations.
- ▶ Adhere to safety measures regarding handling and disposal of cleaning agents.
- ▶ Be aware of potential reactions with product materials.

Risks when shipping**⚠ WARNING****Risk of poisoning from contaminated products**

Where products that contain harmful substances are shipped for maintenance or repair purposes, the health and safety of service personnel is at risk.

- ▶ Comply with the instructions for safe distribution.

Risks during disposal**⚠ WARNING****Health hazard through poisoning from toxic contaminated components or devices**

Toxic process media result in contamination of devices or parts of them. During maintenance work, there is a risk to health from contact with these poisonous substances. Illegal disposal of toxic substances causes environmental damage.

- ▶ Take suitable safety precautions and prevent health hazards or environmental pollution by toxic process media.
- ▶ Decontaminate affected parts before carrying out maintenance work.
- ▶ Wear protective equipment.

2.3 Safety precautions

The product is designed according to the latest technology and recognized safety engineering rules. Nevertheless, improper use can result in danger to operator all third party life and limb, and product damage and additional property damage.

**Duty to provide information on potential dangers**

The product holder or user is obliged to make all operating personnel aware of dangers posed by this product.

Every person who is involved in the installation, operation or maintenance of the product must read, understand and adhere to the safety-related parts of this document.

**Infringement of conformity due to modifications to the product**

The Declaration of Conformity from the manufacturer is no longer valid if the operator changes the original product or installs additional equipment.

- Following the installation into a system, the operator is required to check and re-evaluate the conformity of the overall system in the context of the relevant European Directives, before commissioning that system.

General safety precautions when handling the product

- ▶ Observe all applicable safety and accident prevention regulations.
- ▶ Check that all safety measures are observed at regular intervals.
- ▶ Pass on safety instructions to all other users.
- ▶ Do not expose body parts to the vacuum.
- ▶ Always ensure a secure connection to the earthed conductor (PE).
- ▶ Never disconnect plug connections during operation.
- ▶ Observe the above shutdown procedures.
- ▶ Keep lines and cables away from hot surfaces (> 70 °C).

- ▶ Do not carry out your own conversions or modifications on the device.
- ▶ Observe the unit protection degree prior to installation or operation in other environments.
- ▶ Provide suitable touch protection, if the surface temperature exceeds 70 °C.
- ▶ Inform yourself about any contamination before starting work.

2.4 Limits of use of the product

Parameter		Value
Relative humidity of air (for 30 days of the year)	$1 \times 10^{-8} - 1 \times 10^{-2}$ hPa	≤ 70 % (non-condensing)
	$1 \times 10^{-7} - 1 \times 10^{-2}$ hPa	≤ 95 % (non-condensing)
Mounting orientation		Arbitrary
Usage		Only in indoor areas
Installation altitude max.		6000 m above sea level
Protection degree		IP40

Tbl. 7: Permissible ambient conditions

2.5 Proper use

PKR gauge

The FullRange gauge provides a vacuum measurement of gases within the range of 1×10^{-9} up to 1000 hPa.

IKR gauge

The gauge provides a vacuum measurement of gases within the range of 1×10^{-9} to 1×10^{-2} hPa.

Use the product according to its intended purpose

- ▶ Operate the gauge with a Pfeiffer Vacuum total pressure measuring and control unit or with an evaluation unit provided by the customer.
- ▶ Install, operate and maintain the gauge exclusively as prescribed in these operating instructions.
- ▶ Observe the limits of use prescribed in the technical data.
- ▶ Observe the technical data.

2.6 Foreseeable improper use

Improper use of the product invalidates all warranty and liability claims. Any use that is counter to the purpose of the product, whether intentional or unintentional, is regarded as improper use; in particular:

- Use outside the mechanical and electrical application limits of use (technical data)
- Use with corrosive or explosive media, if this is not explicitly permitted
- **PKR only:** Use for the measurement of highly flammable or combustible gases mixed with an oxidizing agent (e.g. atmospheric oxygen) within the explosion limits.
- Use outdoors
- Use after technical changes (on the inside or the outside of the product)
- Use with replacement or accessory parts that are unsuitable or are not approved

2.7 Responsibilities and warranty

Pfeiffer Vacuum shall assume no responsibilities and warranty if the operating company or a third party:

- disregards this document
- does not use the product for its intended purpose
- carries out any modifications to the product (conversions, changes, etc.) that are not listed in the corresponding product documentation
- operates the product with accessories that are not listed in the corresponding product documentation

The operator is responsible for the process media used.

2.8 Owner requirements

Safety-conscious working

1. Only operate the product in a technically flawless state.
2. Operate the product in line with its intended purpose, safety and hazard-conscious and only in compliance with these operating instructions.
3. Fulfill the following instructions and monitor the observation of the following instructions:
 - Proper use
 - Generally applicable safety instructions and accident prevention regulations
 - International, national and locally applicable standards and guidelines
 - Additional product-related guidelines and regulations
4. Only use original parts or parts approved by Pfeiffer Vacuum.
5. Keep the operating instructions available at the place of installation.
6. Ensure personnel qualification.

2.9 Personnel qualification

The work described in this document may only be carried out by persons who have appropriate professional qualifications and the necessary experience or who have completed the necessary training as provided by Pfeiffer Vacuum.

Training people

1. Train the technical personnel on the product.
2. Only let personnel to be trained work with and on the product when under the supervision of trained personnel.
3. Only allow trained technical personnel to work with the product.
4. Before starting work, make sure that the commissioned personnel have read and understood these operating instructions and all applicable documents, in particular the safety, maintenance and repair information.

2.9.1 Ensuring personnel qualification

Specialist for mechanical work

Only a trained specialist may carry out mechanical work. Within the meaning of this document, specialists are people responsible for construction, mechanical installation, troubleshooting and maintenance of the product, and who have the following qualifications:

- Qualification in the mechanical field in accordance with nationally applicable regulations
- Knowledge of this documentation

Specialist for electrotechnical work

Only a trained electrician may carry out electrical engineering work. Within the meaning of this document, electricians are people responsible for electrical installation, commissioning, troubleshooting, and maintenance of the product, and who have the following qualifications:

- Qualification in the electrical engineering field in accordance with nationally applicable regulations
- Knowledge of this documentation

In addition, these individuals must be familiar with applicable safety regulations and laws, as well as the other standards, guidelines, and laws referred to in this documentation. The above individuals must have an explicitly granted operational authorization to commission, program, configure, mark, and earth devices, systems, and circuits in accordance with safety technology standards.

Trained individuals

Only adequately trained individuals may carry out all works in other transport, storage, operation and disposal fields. Such training must ensure that individuals are capable of carrying out the required activities and work steps safely and properly.

2.9.2 Personnel qualification for maintenance and repair



Advanced training courses

Pfeiffer Vacuum offers advanced training courses to maintenance levels 2 and 3.

Adequately trained individuals are:

- **Maintenance level 1**
 - Customer (trained specialist)
- **Maintenance level 2**
 - Customer with technical education
 - Pfeiffer Vacuum service technician
- **Maintenance level 3**
 - Customer with Pfeiffer Vacuum service training
 - Pfeiffer Vacuum service technician

2.9.3 Advanced training with Pfeiffer Vacuum

For optimal and trouble-free use of this product, Pfeiffer Vacuum offers a comprehensive range of courses and technical trainings.

For more information, please contact [Pfeiffer Vacuum technical training](#).

2.10 Operator requirements

Observing relevant documents and data

1. Read, observe and follow this operating instruction and the work instructions prepared by the operating company, in particular the safety and warning instructions.
2. Install, operate and maintain the product only in accordance with these operating instructions.
3. Carry out all work only on the basis of the complete operating instructions and applicable documents.
4. Comply with the limits of use.
5. Observe the technical data.
6. Please contact the Pfeiffer Vacuum Service Center if your questions on operation or maintenance of the product are not answered in these operating instructions.
 - You can find information in the [Pfeiffer Vacuum service area](#).

3 Product description

3.1 Function

PKR gauge

The gauge has 2 measuring systems:

- Pirani measuring system
- Cold cathode measuring system functioning to the principle of the inverted magnetron

The Pirani measuring circuit is switched on at all times. The cold cathode measuring circuit controlled by the Pirani measuring circuit is only activated by the gauge when the pressures reach $p < 1 \times 10^{-2}$ hPa. Specific linking of both measuring systems ensures that the measuring systems generally behave as one standardized measuring system for the user. The measuring signal is logarithmically dependent on the pressure across the entire measuring range.

The gauge applies the optimum measuring configuration for the respective pressure range:

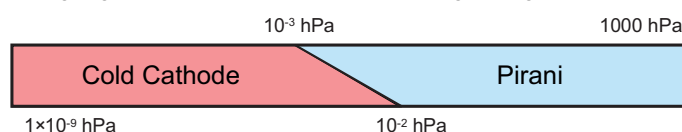

Fig. 1: PKR measuring configuration

IKR gauge

The gauge has a cold cathode measuring system functioning to the principle of the inverted magnetron. The measuring signal is logarithmically dependent on the pressure across the entire measuring range.

3.2 Switch and status display

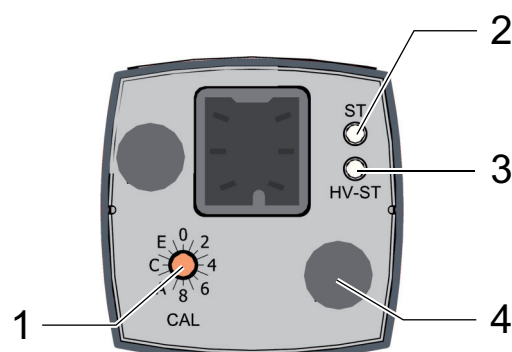

Fig. 2: Switch and LED

- | | |
|--------------------------------------|---|
| 1 Switch for calibration value (CAL) | 3 LED "HV-ST" (high voltage/cold cathode) |
| 2 LED "ST" (supply voltage/error) | 4 (for factory setting only) |

LED		Meaning
"ST"	"HV-ST"	
Off	Off	No power supply
Lights up green	Off	Supply voltage OK, Pirani active, cold cathode off
Lights up yellow	Flashes green	Supply voltage OK, pressure in cold cathode range, cold cathode not ignited
Lights up green	Lights up green	Cold cathode ignited
Lights up red	Off	Measurement system error
Flashes red	Off	EEPROM error
Lights up yellow	Off	Measuring range exceeded
Lights up yellow	Lights up green	Measuring range not reached

Tbl. 8: Illuminating diodes PKR

LED		Meaning
"ST"	"HV-ST"	
Off	Off	No power supply
Lights up yellow	Off	Supply voltage OK, cold cathode off
Lights up yellow	Flashes green	Supply voltage OK, pressure in cold cathode range, cold cathode not ignited
Lights up green	Lights up green	Cold cathode ignited
Flashes red	Off	EEPROM error
Lights up yellow	Lights up green	Measuring range not reached or exceeded

Tbl. 9: Illuminating diodes IKR

3.3 Identifying the product

You will need all the data from the rating plate to safely identify the product when communicating with Pfeiffer Vacuum.

1. Read the data on the product rating plate.
2. Record this data.
3. Always have all rating plate specifications to hand.

3.4 Scope of delivery

The shipment includes the following parts:

- Gauge
- Stylus (Ø 1.1 mm, PKR gauge only)
- Operating instructions

Unpacking the product and checking completeness of the shipment

1. Unpack the product.
2. Remove the transport fasteners, transport protection etc.
3. Store the transport fasteners, transport protection etc. in a safe place.
4. Check that the shipment is complete.
5. Ensure that no parts are damaged.

4 Transport and storage

4.1 Transporting the product

NOTICE

Damage caused by incorrect transport

Transport in unsuitable packaging or failure to install all transport locks can result in damage to the product.

- ▶ Comply with the instructions for safe transport.



Packing

We recommend keeping the transport packaging and original protective cover.

Transport product safely

- ▶ Observe the weight specified on the transport packaging.
- ▶ Where possible, always transport or ship the product in the original transport packaging.
- ▶ Always use dense and impact-proof transport packaging for the product.
- ▶ Remove the existing protective cover and transport protections only immediately prior to installation.
- ▶ Reattach transport locks and transport protections prior to each transport.

4.2 Storing the product

NOTICE

Damage caused by improper storage

Improper storage will lead to damage to the product.

Static charging, moisture, etc. will lead to defects on the electronic components.

- ▶ Comply with the instructions for safe storage.



Packing

We recommend storing the product in its original packaging.

Store product safely

- ▶ Store the product in a cool, dry, dust-free place, where it is protected against impacts and mechanical vibration.
- ▶ Always use dense and impact-proof packaging for the product.
- ▶ Where possible, store the product in its original packaging.
- ▶ Store electronic components in antistatic packaging.
- ▶ Maintain the permissible storage temperature.
- ▶ Avoid extreme fluctuations of the ambient temperature.
- ▶ Avoid high air humidity.
- ▶ Seal connections with the original protective caps.
- ▶ Protect the product with the original transport protection (where available).

5 Installation

5.1 Establishing the vacuum connection

⚠ DANGER

Risk to life due to electric shock

An improperly earthed product is potentially fatal in the event of a fault.

- ▶ Connect the product galvanically with the earthed vacuum chamber.
- ▶ Ensure that the connection complies with the requirements of a protective bonding according to EN 61010. (CF and VCR connections comply with this requirement.)
- ▶ Use electrically conductive centering rings and circlips for KF connections.

⚠ DANGER

Risk to life due to electric shock

If no earth connection is established, voltage flows become hazardous to the touch and could lead to electronic components sustaining damage.

- ▶ Always tighten the electronic unit with the grub screw.
- ▶ Ensure that the grub screw of the electronic unit has been tightened correctly.

⚠ WARNING

Risk of injury resulting from overpressure in the vacuum system

Opening tensioning pieces with an overpressure $> 1000 \text{ hPa}$ in the vacuum system can lead to injuries as a result of flying parts, and escaping process medium could prove harmful to health.

Elastomer seals in KF connections (e.g. O-rings) are not resistant to pressures $> 2500 \text{ hPa}$. This could prove harmful to health due to escaping process medium.

- ▶ Do not open any tensioning pieces when overpressure is prevalent in the vacuum system.
- ▶ Use suitable tensioning pieces for overpressure.
- ▶ Use tensioning pieces which can only be opened and closed using a tool (e.g. tightening strap-circlip).
- ▶ Use sealing rings with an outer centering ring.

NOTICE

Impairment from contamination and damage

Touching the devices or components with bare hands increases the desorption rate and leads to incorrect measurements. Dirt (e.g. dust, fingerprints, etc.) and damage impair the function.

- ▶ When working on high or ultra high vacuum systems, always wear clean, lint-free and powder-free laboratory gloves.
- ▶ Only use clean tools.
- ▶ Make sure that the connection flanges are free of grease.
- ▶ Remove protective caps and protective covers from flanges and connections only when necessary.
- ▶ Carry out all work in a well lit area.

NOTICE

Electric flashover from helium

Helium can cause electric flashovers in the unit's electronics which will destroy the electronics.

- ▶ Switch off the unit before carrying out a leak test.
- ▶ Remove the electronic unit before carrying out a leak test.

Prerequisites

- Appropriate ambient conditions
- Operating temperature within permissible range
- Adequate room available for electrical connection (e.g. permissible bending radii for cables)

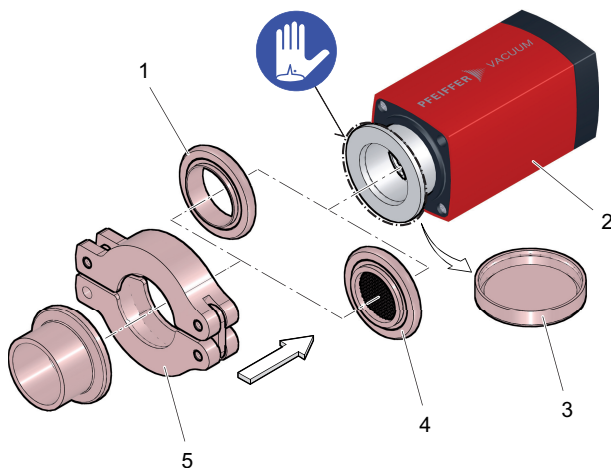

Fig. 3: Establishing the vacuum connection

- | | |
|----------------------------|--|
| 1 Seal with centering ring | 4 Seal with centering ring and filter |
| 2 Electronic unit | 5 Tensioning piece / small flange components |
| 3 Protective cap | |

Recommendations

- ▶ Ensure where possible that the gauge is not exposed to any vibrations during operation, as vibrations in general will lead to deviations in the measured values.
- ▶ Mount the gauge in a horizontal to upright mounting orientation (flange facing downwards).
 - This prevents condensate and particles from accumulating in the measurement chamber.
- ▶ Fit a seal with centering ring and filter for applications susceptible to pollution and to protect the measuring system against contamination.
- ▶ Ensure that the button and the switch of the gauge can be easily accessed with the stylus once fitted.
- ▶ Remove the electronic unit of the gauge temporarily wherever installation is only possible with the electronic unit removed.
 - This will facilitate assembly of the CF flange connection.

Procedure

1. Remove the protective cap and store in a safe place.
2. Assemble the gauge with vacuum components from the [Pfeiffer Vacuum Components Shop](#) on the vacuum system.

5.2 Electronic unit

⚠ DANGER

Risk to life due to electric shock

An improperly earthed product is potentially fatal in the event of a fault.

- ▶ Connect the product galvanically with the earthed vacuum chamber.
- ▶ Ensure that the connection complies with the requirements of a protective bonding according to EN 61010. (CF and VCR connections comply with this requirement.)
- ▶ Use electrically conductive centering rings and circlips for KF connections.

⚠ DANGER

Risk to life due to electric shock

If no earth connection is established, voltage flows become hazardous to the touch and could lead to electronic components sustaining damage.

- ▶ Always tighten the electronic unit with the grub screw.
- ▶ Ensure that the grub screw of the electronic unit has been tightened correctly.

NOTICE**Impairment from contamination and damage**

Touching the devices or components with bare hands increases the desorption rate and leads to incorrect measurements. Dirt (e.g. dust, fingerprints, etc.) and damage impair the function.

- ▶ When working on high or ultra high vacuum systems, always wear clean, lint-free and powder-free laboratory gloves.
- ▶ Only use clean tools.
- ▶ Make sure that the connection flanges are free of grease.
- ▶ Remove protective caps and protective covers from flanges and connections only when necessary.
- ▶ Carry out all work in a well lit area.

Removal of the electronic unit should facilitate assembly and baking out of the gauge.

Required tool

- Allen key, **WAF 2**

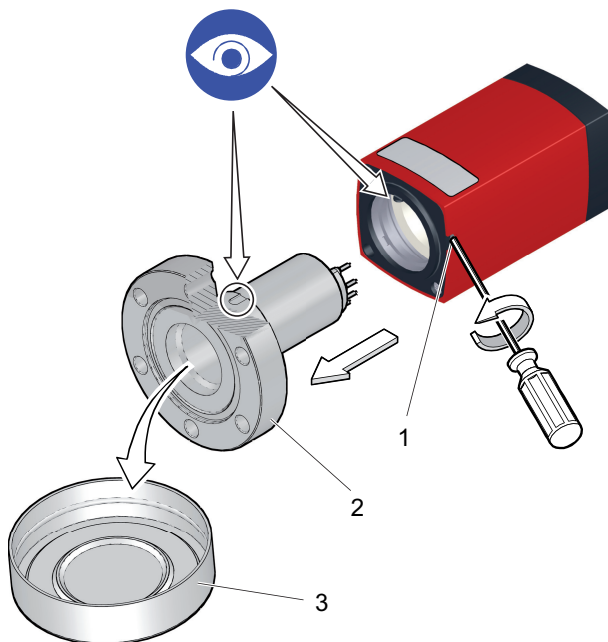

Fig. 4: Electronic unit

- | | |
|----------------------|------------------|
| 1 Set screw | 3 Protective cap |
| 2 Measurement system | |

Removing the electronic unit

1. Loosen the set screw on the side of the electronic unit.
2. Remove the electronic unit without any rotary movement of the measuring system.

Assembling the electronic unit

1. Carefully fit the electronic unit onto the measuring system.
2. Push the electronic unit as far as the stop.
3. Secure the set screw on the side of the electronic unit.

5.3 Establishing the electric connection

⚠ DANGER

Danger to life due to dangerous contact voltage

Voltages above 30 V (AC) or 60 V (DC) are considered dangerous in accordance with EN 61010. If you come into contact with dangerous contact voltage, this can result in injury through electric shocks or even death.

- ▶ Only connect the product to devices which meet the following criteria:
 - Requirements of the earthed protective extra-low voltage (PELV)
 - Limited power source (LPS) Class 2
- ▶ Secure the line to the product.
 - Pfeiffer Vacuum measuring and control equipment complies with this requirement.

NOTICE

Damage sustained as a result of improper connection

Improper connection, incorrect polarity or impermissible supply voltage will damage the gauge.

- ▶ Always connect the supply earth (Pin 5) with the earth for the supply unit.
- ▶ Always connect the shielding (Pin 6) with the earth for the supply unit.

Required tools

- Crosshead screwdriver
- Torque wrench (≤ 0.2 Nm)

Required materials

- Measurement cable for a Pfeiffer vacuum total pressure measuring and control unit from the [ActiveLine accessories range](#)
- Self-fabricated measurement cable for an evaluation unit provided by the customer
- Hirschmann cable socket

Establishing the electric connection

1. Connect the measurement cable to the gauge.
2. Tighten the locking screw on the Hirschmann cable socket.
 - Tightening torque: ≤ 0.2 Nm
3. Connect the gauge to a Pfeiffer Vacuum total pressure measuring and control unit, or to an evaluation unit provided by the customer.

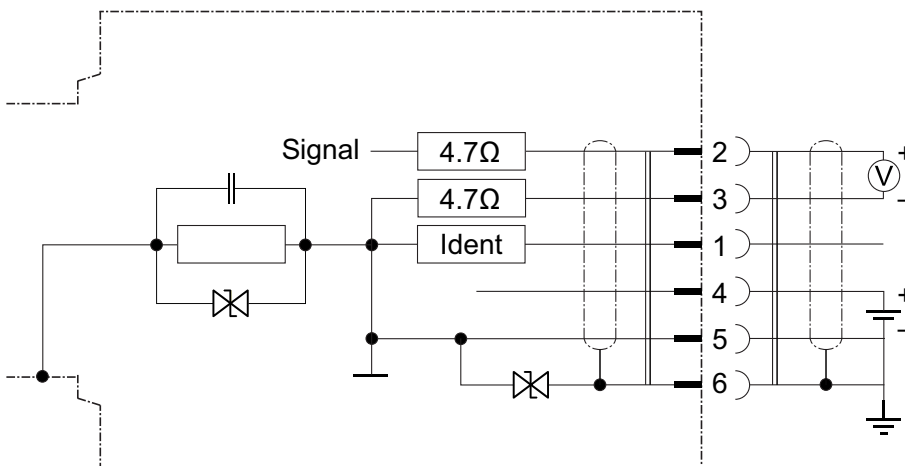

Fig. 5: Connection diagram

- | | | | |
|---|------------------|---|----------------------|
| 1 | Identification | 4 | Supply |
| 2 | Measuring signal | 5 | Supply earth (GND) |
| 3 | Signal earth | 6 | Screening, shielding |

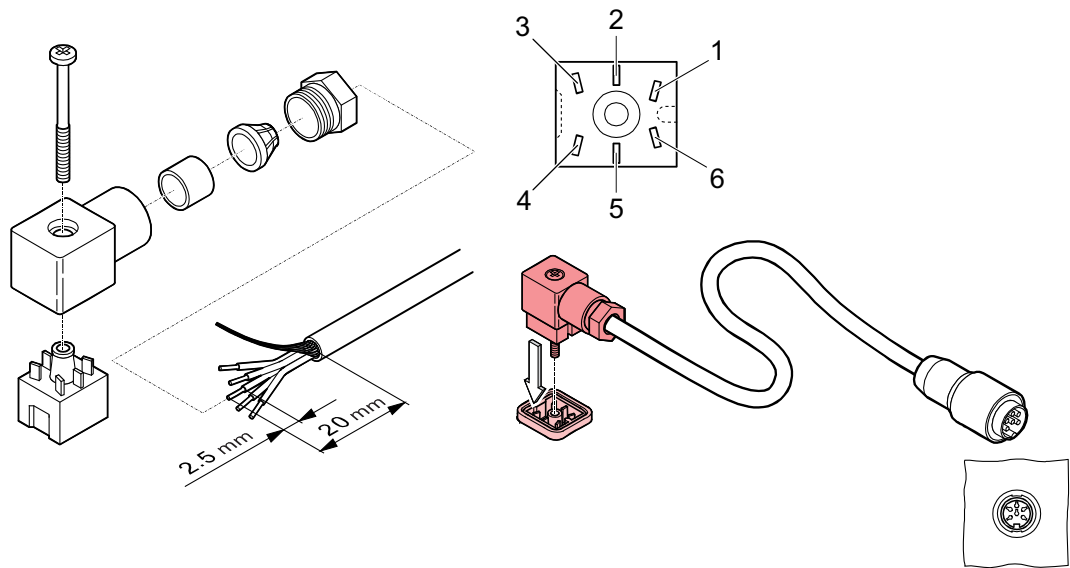

Fig. 6: Measurement cable and Hirschmann cable socket

Manufacturing a measurement cable

You can find additional information regarding measurement cable type and conductor cross-sections in the technical data.

1. Observe the following steps to ensure optimum signal quality, whereby ground loops, differences in potential or EMC will influence the measuring signal.
2. Use a cable with braided shield.
3. Connect the supply earth directly with the protective earth for power supply pack.
4. Use a differential measuring input and separate signal earth and supply earth.
5. Ensure that the potential difference for surge protection between supply earth and housing is $\leq 6\text{ V}$.
6. Assemble the Hirschmann cable socket.

Assembling the Hirschmann cable socket

1. Prepare the Hirschmann cable socket as shown in the "Measurement cable and Hirschmann cable socket" diagram.
2. Solder in the connection cable as prescribed in the terminal connection diagram.
3. Assemble the Hirschmann cable socket.

6 Operation



Controlling the IKR gauge with a Pirani gauge

For Pfeiffer Vacuum total pressure measuring and control units with at least 2 gauge connections, the IKR gauge can be controlled with a Pirani gauge, for example.

Once the supply voltage has been established, the measuring signal is available at the electrical connection between pins 2 and 3.

Recommendations for the PKR gauge

- ▶ Respect the stabilization period of at least 10 minutes.
- ▶ Respect the relation between measuring signal and pressure.
- ▶ Leave the gauge switched on at all times, regardless of the prevalent pressure.

Recommendations for the IKR gauge

- ▶ Respect the relation between measuring signal and pressure.
- ▶ Only switch the gauge on at pressures $< 10^{-2}$ hPa to avoid excessive contamination.

6.1 Operating modes PKR

The identification output shows the respective operating status set for the PKR gauge. As long as the cold cathode measuring circuit has not ignited, the signal output issues solely the Pirani measured value once again. (if $p < 5 \times 10^{-4}$ hPa: display "Pirani-Underrange").

Pressure	LED		Operations mode	Identification
	"ST"	"HV-ST"		
$p > 1 \times 10^{-2}$ hPa	Lights up green	Off	Pirani operation	11.1 k Ω (Pirani)
$p < 1 \times 10^{-2}$ hPa	Lights up yellow	Flashes green	Pirani operation (cold cathode measuring system not ignited)	11.1 k Ω (Pirani)
	Lights up green		Combined operation	9.1 k Ω (combination)

Tbl. 10: Operating modes PKR

6.2 Converting the PKR measuring signal and pressure

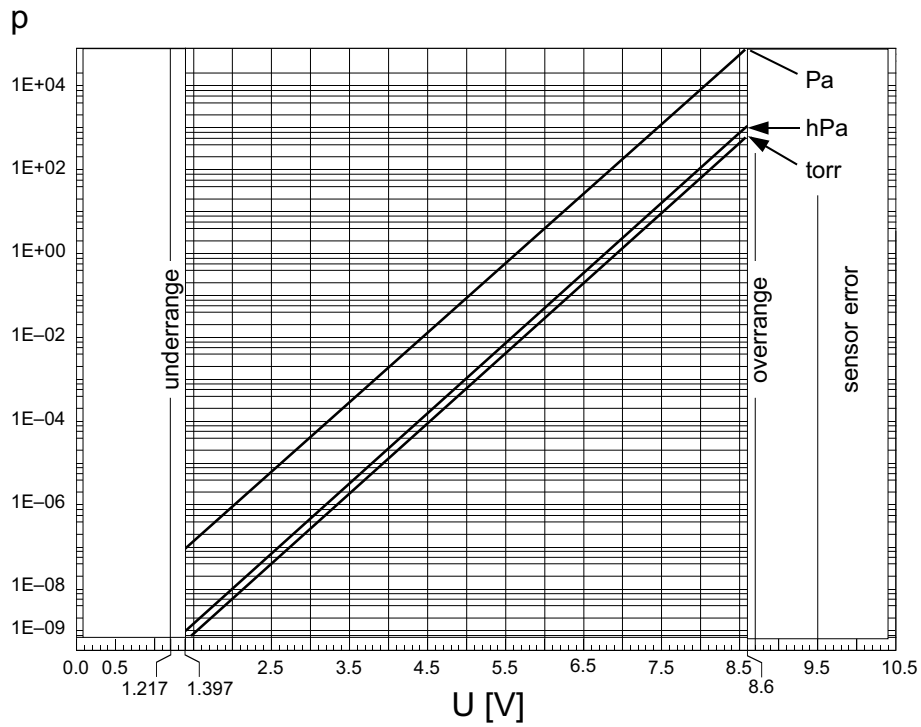

Fig. 7: Relation between measuring signal and pressure

p Pressure U Measuring signal [V] (output voltage)

Measuring signal (U)	Pressure (p)	Constant (c) ¹⁾	Constant (d) ²⁾
[V]	[hPa]	6.8	11.33
	[mbar]		
	[Torr]	6.875	11.46
	[micron]	5.075	8.458
	[Pa]	5.6	9.333

Tbl. 11: Constants for converting measuring signal and pressure

Converting measuring signal and pressure

Validity range

- 1×10^{-9} hPa < p < 1000 hPa
- 7.5×10^{-10} Torr < p < 750 Torr
- 1×10^{-7} Pa < p < 1×10^5 Pa

► Observe the constants for converting measuring signal and pressure.

► Convert measuring signal into pressure:

$$p = 10^{(1.667 \times U - d)}$$

► Convert pressure into measuring signal:

$$U = c + 0.6 \times \log_{10} p$$

1) Dependent upon unit of pressure

2) Dependent upon unit of pressure

6.3 Converting the IKR measuring signal and pressure

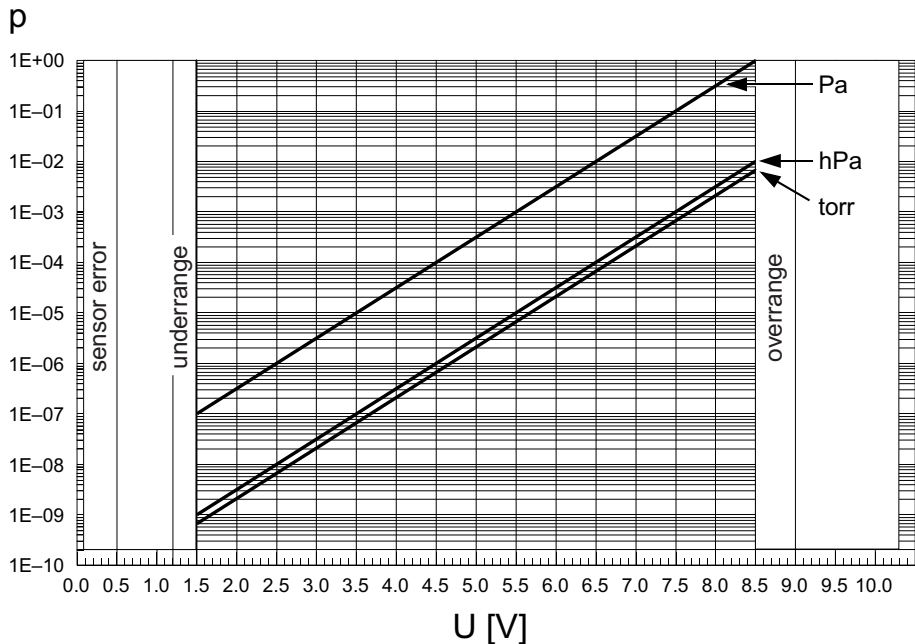

Fig. 8: Relation between measuring signal and pressure

p Pressure U Measuring signal [V]

Measuring signal (U)	Pressure (p)	Constant (c) ³⁾
[V]	[hPa]	10.5
	[mbar]	
	[Torr]	10.625
	[micron]	7.625
	[Pa]	8.5

Tbl. 12: Constants for converting measuring signal and pressure

Converting measuring signal and pressure

Validity range

- $1 \times 10^{-9} \text{ hPa} < p < 1 \times 10^{-2} \text{ hPa}$
- $7.5 \times 10^{-10} \text{ Torr} < p < 7.5 \times 10^{-3} \text{ Torr}$
- $1 \times 10^{-7} \text{ Pa} < p < 1 \text{ Pa}$

- ▶ Observe the constants for converting measuring signal and pressure.
- ▶ Convert measuring signal into pressure:

$$p = 10^{(U-c)}$$

- ▶ Convert pressure into measuring signal:

$$U = c + \log_{10} p$$

6.4 Determining effective pressure with calibration factors

The measuring signal is gas type-dependent. The characteristics apply for nitrogen (N₂), oxygen (O₂), dry air and carbon monoxide (CO).

3) Dependent upon unit of pressure

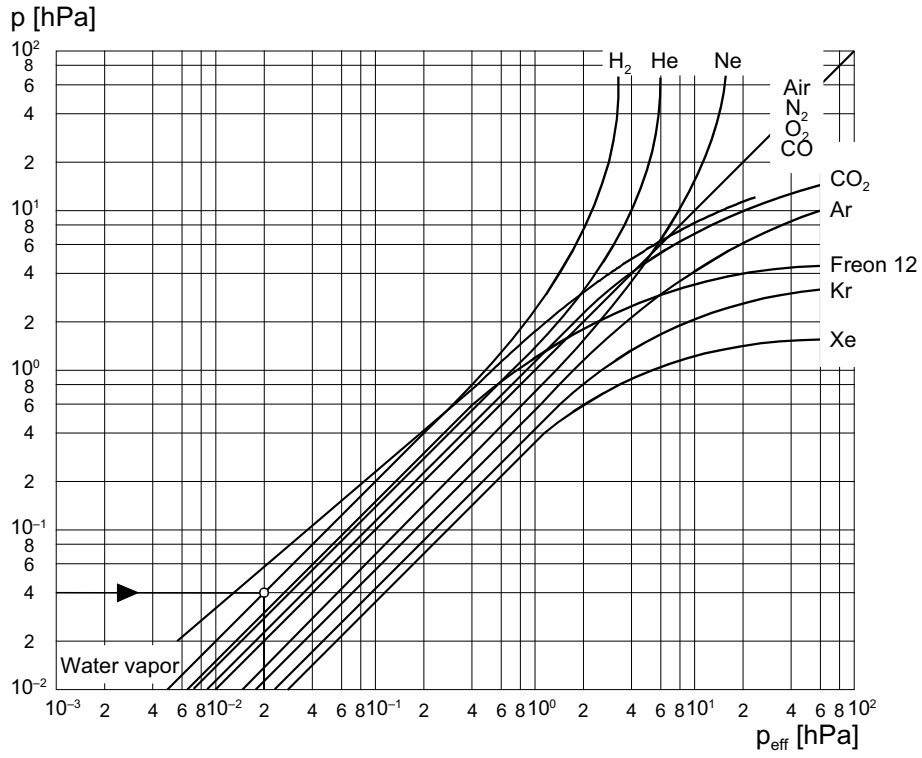

Fig. 9: Pressure range $> 10^{-2}$ hPa exclusively with Pirani operation PKR

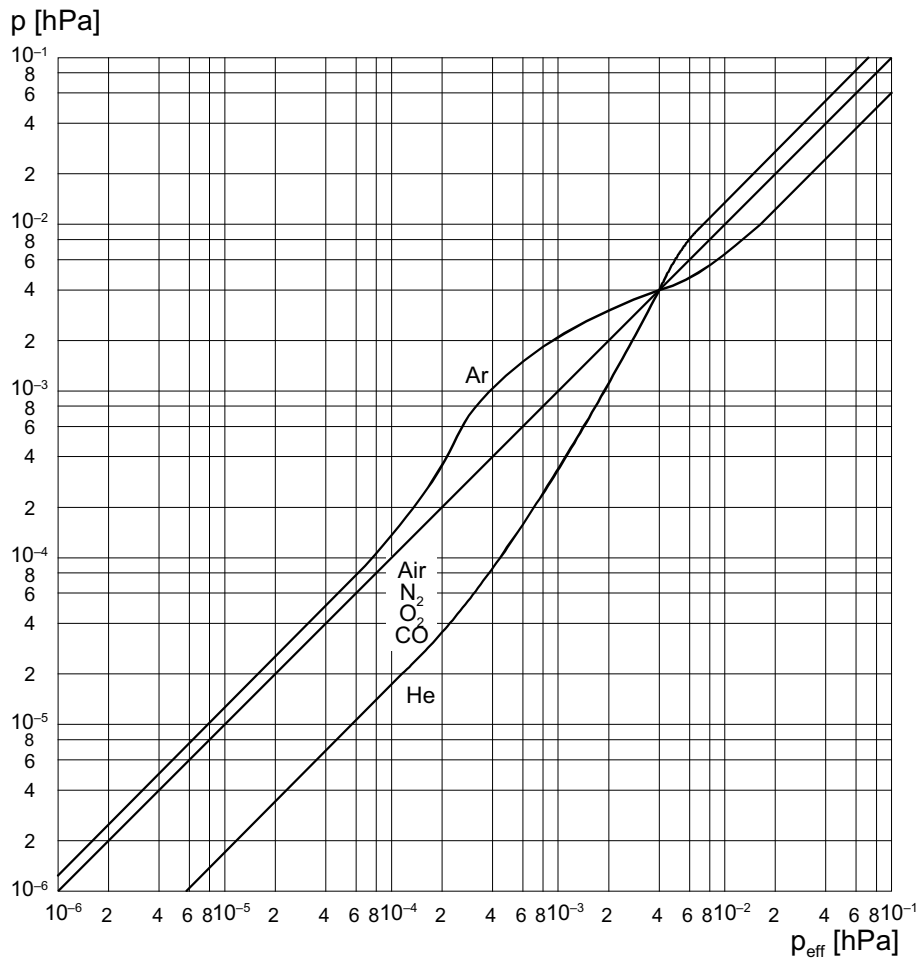

Fig. 10: Pressure range from 10^{-6} to 0.1 hPa PKR

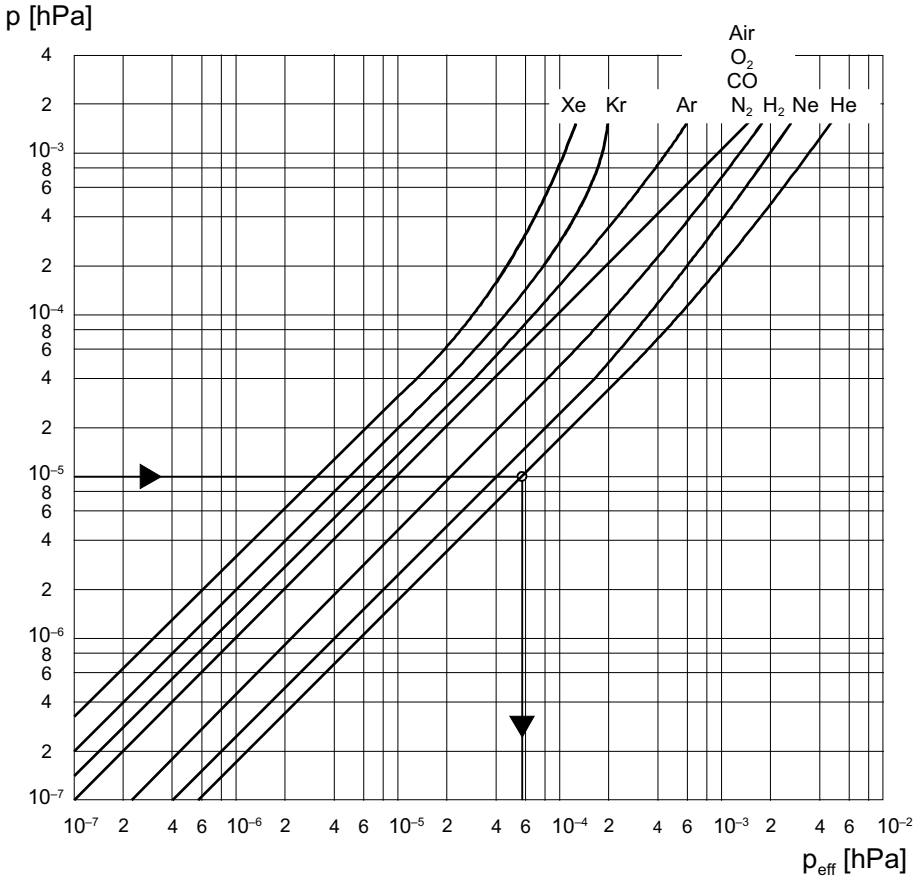

Fig. 11: Displayed pressure IKR

Calibration factors

In the pressure range < 10⁻⁵ hPa, the display is linear.

i

Gas and vapor mixtures

Process gases are mostly mixtures of gas and vapor. Precise measuring of gas and vapor mixtures is only possible using partial pressure measurement instruments, for example a quadrupole mass spectrometer.

Gas type	Calibration factor (C)
Air, oxygen (O ₂), carbon monoxide (CO), nitrogen (N ₂)	1.0
Hydrogen (H ₂)	2.4
Helium (He)	5.9
Neon (Ne)	4.1
Argon (Ar)	0.8
Krypton (Kr)	0.5
Xenon (Xe)	0.4

The calibration factors provided are mean values.

Tbl. 13: Calibration factors for the pressure range < 10⁻⁵ hPa PKR and IKR

Gas type	Calibration factor (C)
Air, oxygen (O ₂), carbon monoxide (CO), nitrogen (N ₂)	1.0
Hydrogen (H ₂)	0.5
Carbon dioxide (CO ₂)	0.9

The calibration factors provided are mean values.

Gas type	Calibration factor (C)
Water vapor	0.5
Freon 12	0.7
Helium (He)	0.8
Neon (Ne)	1.4
Argon (Ar)	1.7
Krypton (Kr)	2.4
Xenon (Xe)	3.0

The calibration factors provided are mean values.

Tbl. 14: Calibration factors for the pressure range $0.02 \text{ hPa} < p_{\text{rms}} < 1 \text{ hPa}$ in Pirani operation only PKR

Entering the calibration factor in a total pressure measuring and control unit

- ▶ Enter the calibration factor to correct the displayed measured value.

Calculating pressure for gases other than air

- ▶ Calculate the effective pressure using the following formula:

$$P_{\text{eff}} = C \times p$$

- P_{eff} = Effective pressure
- C = Calibration factor
- p = Displayed pressure (gauge calibrated for air)

6.5 Ignition delay

Cold cathode measuring systems have an ignition delay upon activation. This ignition delay is longer for lower pressures and is typically in clean, degassed units:

- 1×10^{-5} up to 1×10^{-2} hPa < 1 second
- 1×10^{-7} up to 1×10^{-5} hPa < 20 seconds
- 5×10^{-9} up to 1×10^{-7} hPa < 2 minutes
- $< 5 \times 10^{-9}$ hPa < 20 minutes

The ignition is a static process, for which even minimal depositions can have a major influence on the inner surfaces.

PKR gauge



Switching on at pressure $p < 3 \times 10^{-9}$ hPa

If you switch on the gauge at a pressure $p < 3 \times 10^{-9}$ hPa, the gauge will not be able to detect whether the cold cathode measurement system has ignited. The gauge displays "Pirani-Underrange".



Maintaining operation of the gauge

If continuous operation of the flange-mounted gauge is maintained regardless of the pressure range, the ignition delay time of the cold cathode measurement system is always negligible (< 1 s), with minimal thermal stabilization effects.

As long as the cold cathode measuring circuit has not ignited, the signal output issues solely the Pirani measured value once again (display "Pirani underrange" for pressures $p < 5 \times 10^{-4}$ hPa). The identification output signals solely Pirani operation.

6.6 Contamination



Warranty

Malfunctioning of the equipment as a direct result of wear or wear parts (e.g. ionization chamber) is not covered by the warranty.

Contamination of the gauge is dependent upon

- pressure in the vacuum chamber
- the type of process media
- potentially existing or newly accumulated contamination or its partial pressure (e.g. vapors, process particles etc.)
- the operating time

Continuous operation in the range between 10^{-4} hPa and 10^{-2} hPa can lead to major contamination, and thus reduced service life and shorter maintenance intervals.

Contamination of the gauge generally leads to deviations in the measured values:

- PKR only: Within the range of **high pressures** (1×10^{-3} hPa to 0.1 hPa), the pressure displayed is too high (contamination of the Pirani element). The Pirani measurement system must be recalibrated.
- PKR and IKR: Within the range of **low pressures** ($< 1 \times 10^{-3}$ hPa), the pressure displayed is generally too low (contamination of the cold cathode system). Excessive contamination will cause instabilities (separation of layers in the measurement chamber). This can lead to short circuiting. Complete quenching of the gas discharge is also possible in the event of contamination resulting from insulating layers (display: "underrange").

Influencing the degree of pollution

It is possible to influence the level of contamination to a certain extent. Particular care should be taken in the case of vapors that deposit in the plasma (e.g. of the cold cathode measuring system).

- ▶ Implement geometric safety measures (screening sheets, bends) for particles propagated in a straight line.
- ▶ Choose a flange position in which the partial pressure of the contamination is at a minimum.
- ▶ Switch off the gauge when depositing vapors are present.
- ▶ Protect the sensor during the process-related occurrence of separating vapors by shut-off devices (e.g. valve).

7 Disassembly

DANGER

Risk to life due to electric shock

An improperly earthed product is potentially fatal in the event of a fault.

- ▶ Connect the product galvanically with the earthed vacuum chamber.
- ▶ Ensure that the connection complies with the requirements of a protective bonding according to EN 61010. (CF and VCR connections comply with this requirement.)
- ▶ Use electrically conductive centering rings and circlips for KF connections.

WARNING

Health hazard through poisoning from toxic contaminated components or devices

Toxic process media result in contamination of devices or parts of them. During maintenance work, there is a risk to health from contact with these poisonous substances. Illegal disposal of toxic substances causes environmental damage.

- ▶ Take suitable safety precautions and prevent health hazards or environmental pollution by toxic process media.
- ▶ Decontaminate affected parts before carrying out maintenance work.
- ▶ Wear protective equipment.

WARNING

Risk of injury resulting from overpressure in the vacuum system

Opening tensioning pieces with an overpressure > 1000 hPa in the vacuum system can lead to injuries as a result of flying parts, and escaping process medium could prove harmful to health.

Elastomer seals in KF connections (e.g. O-rings) are not resistant to pressures > 2500 hPa. This could prove harmful to health due to escaping process medium.

- ▶ Do not open any tensioning pieces when overpressure is prevalent in the vacuum system.
- ▶ Use suitable tensioning pieces for overpressure.
- ▶ Use tensioning pieces which can only be opened and closed using a tool (e.g. tightening strap-circlip).
- ▶ Use sealing rings with an outer centering ring.

NOTICE

Impairment from contamination and damage

Touching the devices or components with bare hands increases the desorption rate and leads to incorrect measurements. Dirt (e.g. dust, fingerprints, etc.) and damage impair the function.

- ▶ When working on high or ultra high vacuum systems, always wear clean, lint-free and powder-free laboratory gloves.
- ▶ Only use clean tools.
- ▶ Make sure that the connection flanges are free of grease.
- ▶ Remove protective caps and protective covers from flanges and connections only when necessary.
- ▶ Carry out all work in a well lit area.

Prerequisites

- Vacuum system vented to atmospheric pressure
- Supply voltage switched off

Required tools

- Crosshead screwdriver

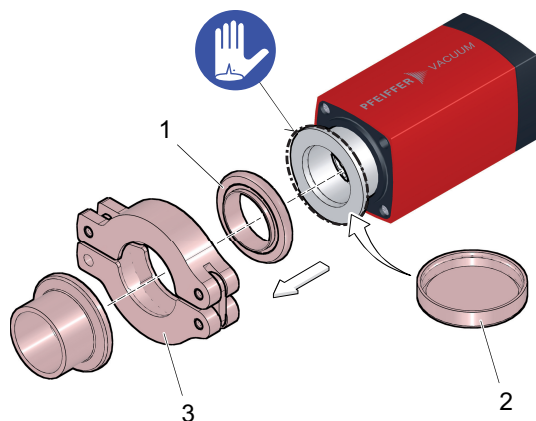

Fig. 12: Disassembling the gauge

- | | |
|----------------------------|--------------------|
| 1 Seal with centering ring | 3 Tensioning piece |
| 2 Protective cap | |

Disassembling the gauge

1. Loosen the locking screw of the Hirschmann cable socket on the gauge.
2. Disconnect the measurement cable from the gauge.
3. Recommendation: Remove the electronic unit of the gauge temporarily if disassembling is only possible with the electronic unit removed.
 - This will facilitate disassembling of the CF flange connection.
4. Remove the gauge from the vacuum system.
5. Fit the protective cap onto the connection flange.

8 Maintenance

WARNING

Health hazard through poisoning from toxic contaminated components or devices

Toxic process media result in contamination of devices or parts of them. During maintenance work, there is a risk to health from contact with these poisonous substances. Illegal disposal of toxic substances causes environmental damage.

- ▶ Take suitable safety precautions and prevent health hazards or environmental pollution by toxic process media.
- ▶ Decontaminate affected parts before carrying out maintenance work.
- ▶ Wear protective equipment.



Maintenance in the Pfeiffer Vacuum Service Center

Pfeiffer Vacuum offers a complete maintenance service for all products.

Pfeiffer Vacuum recommends: Contact your Pfeiffer Vacuum Service Center to arrange the maintenance of defective products and components.



Cleaning in the Pfeiffer Vacuum Service Center

Pfeiffer Vacuum recommends: Contact your nearest Pfeiffer Vacuum Service Center to arrange the cleaning of heavily-soiled products and components.



Warranty claim

Opening the device during the warranty period or damaging/removing the warranty seal will void the warranty.

Contact the Pfeiffer Vacuum Service Center in the event of process-related shorter maintenance intervals.



First read through the sections completely

Read the section with the work instructions through completely first before you commence with work.

Other climatic conditions, long-term operation, extreme temperatures, a different mounting orientation, and aging or contamination can lead to a zero point shift in the Pirani measurement system. A zero point shift will necessitate recalibration or cleaning.

8.1 Calibrating the PKR gauge

Pfeiffer Vacuum has calibrated the gauge to standard values at the factory.

The dominant cold cathode measuring circuit for the low pressure range ($< 1 \times 10^{-3}$ hPa) has undergone a fixed calibration by Pfeiffer Vacuum ex factory. HV calibration of the Pirani measuring circuit is performed automatically during operation for pressures 1×10^{-5} hPa. The gauge stores the new zero point value every 15 minutes in the fail-safe memory. The pressure range between approx. 10^{-2} hPa and 10^2 hPa is scarcely influenced during calibration. Manual HV calibration is necessary when the gauge is no longer providing pressures $< 10^{-2}$ hPa.

Required tools

- Stylus (max. \varnothing 1.1 mm)

Preparing for calibration

1. Ensure the same installation and ambient conditions as those applicable for normal use.
2. Check the filter for contamination as required.
3. Replace the filter if the filter is contaminated or damaged.
4. Put the gauge into operation.

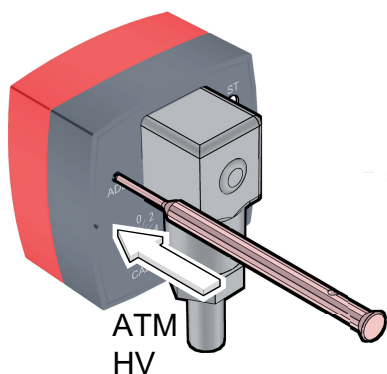

Fig. 13: Calibrating the PKR gauge

Performing an HV calibration

1. Perform commissioning of the gauge.
2. Evacuate the vacuum system to $p < 10^{-5}$ hPa.
3. Wait for at least 2 minutes.
4. Press the "ADJ" button briefly using a stylus.
 - The Pirani sensor calibrates to 1×10^{-5} hPa (standard). Calibration requires approx. 5 seconds.
5. Repeat the calibration if a pressure of 1×10^{-5} hPa is **not** displayed by the gauge at the measuring signal output.
 - The calibration was not successful this time.

Performing an ATM calibration

1. Perform commissioning of the gauge.
2. Operate the gauge for at least 10 minutes at atmospheric pressure.
3. Press the "ADJ" button briefly using a stylus.
 - The Pirani sensor calibrates to 1000 hPa (standard). Calibration requires approx. 5 seconds.
4. Repeat the calibration if a pressure of 1000 hPa is **not** displayed by the gauge at the measuring signal output.
 - The calibration was not successful this time.

8.2 Maintaining the IKR gauge

Pfeiffer Vacuum has calibrated the gauge to standard values at the factory. The gauge is maintenance-free.

Replacing faulty components

- ▶ Replace the ionization chamber and the ignition aid or the complete measurement chamber (replacement sensor) only if the unit is faulty.
- ▶ Replace the complete measurement chamber if heavily contaminated or faulty.

8.3 Disassembling the gauge

NOTICE

Impairment from contamination and damage

Touching the devices or components with bare hands increases the desorption rate and leads to incorrect measurements. Dirt (e.g. dust, fingerprints, etc.) and damage impair the function.

- ▶ When working on high or ultra high vacuum systems, always wear clean, lint-free and powder-free laboratory gloves.
- ▶ Only use clean tools.
- ▶ Make sure that the connection flanges are free of grease.
- ▶ Remove protective caps and protective covers from flanges and connections only when necessary.
- ▶ Carry out all work in a well lit area.

Required tools

- Allen key, **WAF 2**
- Pincers for circlip
- Tweezers

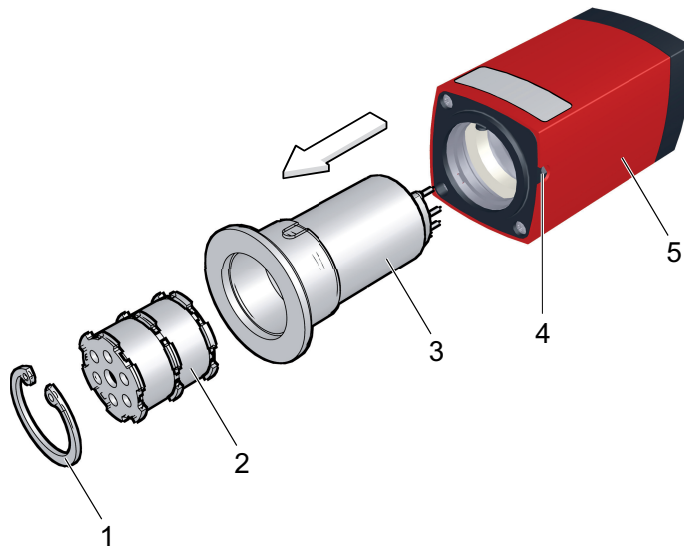

Fig. 14: Disassembling the gauge

- | | |
|-----------------------|-------------------|
| 1 Circlip | 4 Set screw |
| 2 Ionization chamber | 5 Electronic unit |
| 3 Measurement chamber | |

Disassembling the gauge

1. Remove the gauge from the vacuum system.
2. Loosen the set screw on the side of the electronic unit.
3. Remove the complete measurement chamber from the electronic unit.
4. Removing the circlip.
5. Remove the ionization chamber from the measurement chamber.

8.4 Replacing the ignition aid

NOTICE

Impairment from contamination and damage

Touching the devices or components with bare hands increases the desorption rate and leads to incorrect measurements. Dirt (e.g. dust, fingerprints, etc.) and damage impair the function.

- ▶ When working on high or ultra high vacuum systems, always wear clean, lint-free and powder-free laboratory gloves.
- ▶ Only use clean tools.
- ▶ Make sure that the connection flanges are free of grease.
- ▶ Remove protective caps and protective covers from flanges and connections only when necessary.
- ▶ Carry out all work in a well lit area.

Required tools

- Mounting tool for the ignition aid
- Tweezers

Spare part required

- Ignition aid

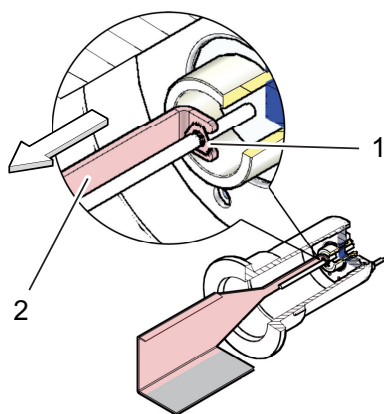

Fig. 15: Removing the ignition aid

- 1 Ignition aid
- 2 Mounting tool

Removing the ignition aid

- ▶ Remove the ignition aid.

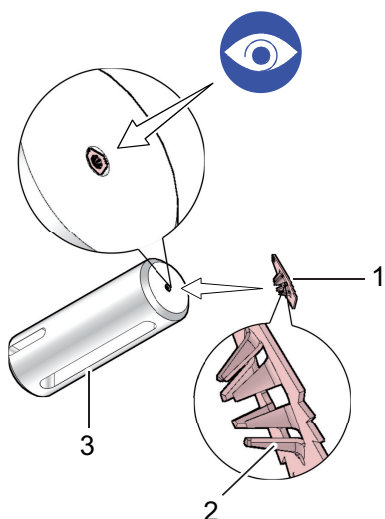

Fig. 16: Inserting the ignition aid in the mounting tool

- 1 Ignition aid
- 2 Serrated end of ignition aid
- 3 Mounting tool

Inserting the ignition aid in the mounting tool

1. Insert the new ignition aid in the mounting tool.
2. Ensure correct position of the ignition aid (serrated end at the bottom).

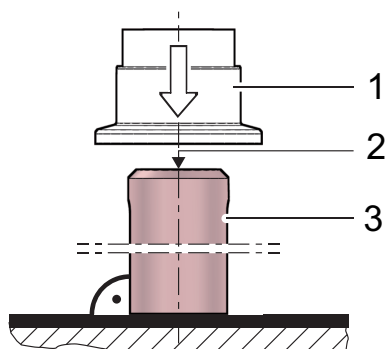

Fig. 17: Inserting the ignition aid

- 1 Measurement chamber (with anode)
- 2 Ignition aid
- 3 Mounting tool

Inserting the ignition aid

- ▶ Carefully push the measurement chamber with anode (either new or cleaned) into the mounting tool, centrally and parallel to the tool axis up to the stop.

8.5 Cleaning of components**⚠ DANGER****Electric shock due to moisture entering the unit**

Water that has entered the unit will result in personal injury through electric shocks.

- ▶ Only operate the unit in a dry environment.
- ▶ Operate the unit away from fluids and sources of moisture.
- ▶ Do not switch on the unit if fluid has entered it. Instead contact Pfeiffer Vacuum Service.
- ▶ Always disconnect the power supply before cleaning the unit.

⚠ WARNING**Health hazards due to cleaning agent**

The cleaning agent being used causes health hazards which could include, for example, poisoning, allergies, skin irritations, chemical burns or damage to the airways.

- ▶ When handling cleaning agents, observe the applicable regulations.
- ▶ Adhere to safety measures regarding handling and disposal of cleaning agents.
- ▶ Be aware of potential reactions with product materials.

NOTICE**Damage caused by penetrating moisture**

Penetrating moisture, e.g. through condensation or dripping water, damages the device.

- ▶ Protect the device against moisture penetrating.
- ▶ Only operate the device in a clean and dry environment.
- ▶ Operate the device away from fluids and humidity sources.
- ▶ Take special precautions if there is a risk of dripping water.
- ▶ Do not switch on the device if fluid has penetrated into it, instead contact the Pfeiffer Vacuum Service Center.

NOTICE**Damage caused by unsuitable cleaning agents**

Unsuitable cleaning agents damage the product.

- ▶ Do not use solvents as they attack the surface.
- ▶ Do not use any aggressive or abrasive cleaning agents.

Required consumables

- Polishing cloth (400 grade or Scotch-Brite)
- Industrial alcohol
- Cloth (soft, lint-free)

External cleaning of the device

1. Always use a cloth soaked in industrial alcohol for external cleaning.
2. Allow the surfaces to dry thoroughly after cleaning.

Check components for contamination

1. Check the ionization chamber for contamination.
2. Check the measurement chamber for contamination.
3. Check the ignition aid for contamination.
4. Replace the ionization chamber if only the ionization chamber is contaminated.
5. Replace the complete measurement chamber if the measurement chamber is heavily contaminated.
6. Replace the ignition aid if the ignition aid is contaminated.

Cleaning of components

1. Disassemble the gauge to the degree required.
 - Do not bend the anode.
2. Remove the old ignition aid.
3. Only perform work on the sealing surfaces concentrically.
4. Rub the inside walls of the measurement chamber up to the groove of the circlip with the polishing cloth until shiny.
5. Insert a new ignition aid.
6. Re-assemble the gauge.

8.6 Gauge assembling

⚠ DANGER

Risk to life due to electric shock

If no earth connection is established, voltage flows become hazardous to the touch and could lead to electronic components sustaining damage.

- ▶ Always tighten the electronic unit with the grub screw.
- ▶ Ensure that the grub screw of the electronic unit has been tightened correctly.

NOTICE

Impairment from contamination and damage

Touching the devices or components with bare hands increases the desorption rate and leads to incorrect measurements. Dirt (e.g. dust, fingerprints, etc.) and damage impair the function.

- ▶ When working on high or ultra high vacuum systems, always wear clean, lint-free and powder-free laboratory gloves.
- ▶ Only use clean tools.
- ▶ Make sure that the connection flanges are free of grease.
- ▶ Remove protective caps and protective covers from flanges and connections only when necessary.
- ▶ Carry out all work in a well lit area.

NOTICE

Electric flashover from helium

Helium can cause electric flashovers in the unit's electronics which will destroy the electronics.

- ▶ Switch off the unit before carrying out a leak test.
- ▶ Remove the electronic unit before carrying out a leak test.

Required tools

- Allen key, **WAF 2**
- Pincers for circlip
- Tweezers

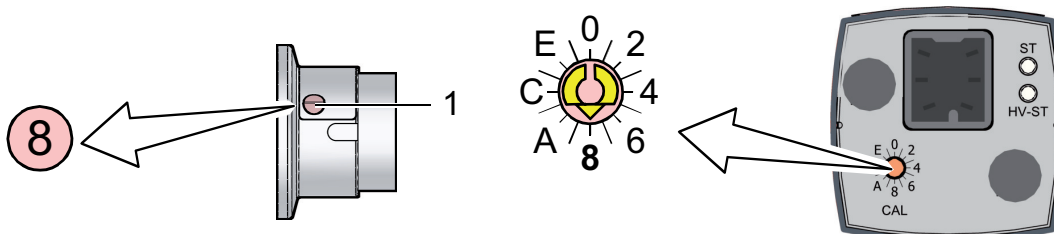

Fig. 18: Switch for CAL calibration value

- 1 Calibration value for replacement sensor (complete measurement chamber)

Setting the calibration value of the replacement sensor

- ▶ Set the calibration value for the replacement sensor at the switch for the calibration value (CAL) of the electronic unit.
- ▶ If you replace the entire measurement chamber, remember to set the calibration factor again afterwards.

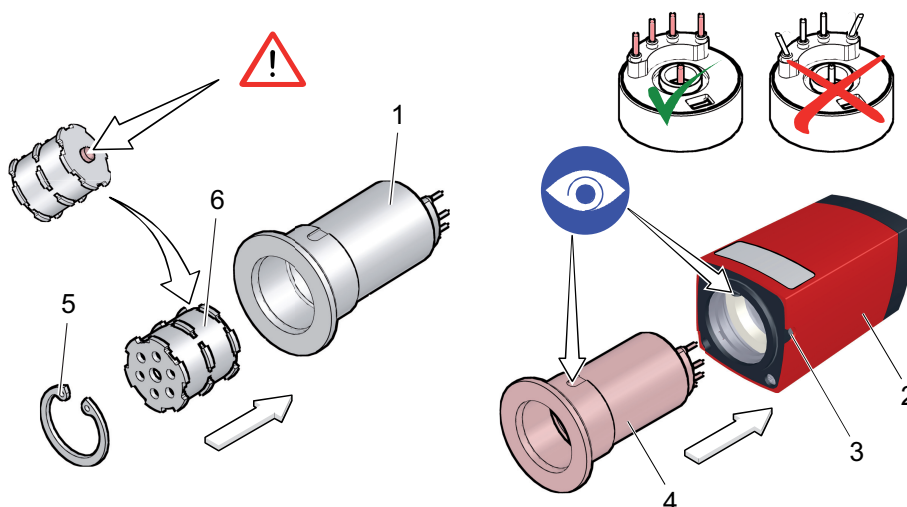

Fig. 19: Gauge assembling

- | | |
|-----------------------|----------------------------------|
| 1 Measurement chamber | 4 Measurement chamber (complete) |
| 2 Electronic unit | 5 Circlip |
| 3 Grub screw | 6 Ionization chamber |

Fitting the PKR gauge

1. Replace the ignition aid as required (see chapter "Replacing the ignition aid", page 36).
2. Observe arrangement of the ionization chamber.
3. Push the ionization chamber into the measurement chamber up to the mechanical stop.
4. Fit the circlip.
5. Perform a leak test where possible.
 - Leakage rate <math>< 10^{-9}</math> hPa l/s
6. Push the complete measurement chamber into the electronic unit up to the mechanical stop.
7. Ensure in this regard that the pins remain straight.
8. Secure the grub screw on the side of the electronic unit.
9. Perform a manual ATM and HV calibration.

Fitting the IKR gauge

1. Replace the ignition aid as required (see chapter "Replacing the ignition aid", page 36).
2. Observe arrangement of the ionization chamber.
3. Push the ionization chamber into the measurement chamber up to the mechanical stop.
4. Fit the circlip.
5. Perform a leak test where possible.
 - Leakage rate <math>< 10^{-9}</math> hPa l/s
6. Push the complete measurement chamber into the electronic unit up to the mechanical stop.
7. Ensure in this regard that the pins remain straight.
8. Secure the grub screw on the side of the electronic unit.

9 Malfunctions



Warranty

Malfunctioning of the equipment as a direct result of wear or wear parts (e.g. ionization chamber) is not covered by the warranty.



Rectifying malfunctions (reset)

In the event of a malfunction, Pfeiffer Vacuum recommends disconnecting the supply voltage, and then reconnecting after 5 seconds.

9.1 Troubleshooting

Malfunction	LED		Possible cause	Remedy
	"ST"	"HV-ST"		
No voltage at signal output	Off	Off	No supply	Switch the supply on.
Measuring signal unstable	Lights up green	Lights up green	Gauge contaminated	Replace the ionization chamber or the complete measurement chamber.
Voltage at signal output < 4.82 V (< 5×10^{-4} hPa) not possible.	Lights up yellow	Flashes green	Gas discharge has not ignited	Wait until the gas discharge ignites (approx. 5 minutes with a pressure of 10^{-9} hPa).
Voltage at signal output constantly > 5.6 V (> 0.01 hPa)	Lights up green	Off	Pirani zero point shift	Perform a manual HV calibration.
Voltage at signal output constantly > 9.5 V (sensor error)	Lights up red	Off	Pirani faulty	Replace the complete measurement chamber.
	Flashes red	Off	EEPROM error	Switch the gauge off, wait 5 seconds and then switch it back on (reset). Replace the gauge.
Signal constant with approx. 4.82 V (5×10^{-4} hPa).	Lights up green	Lights up green	Measurement chamber heavily contaminated	Replace the complete measurement chamber.

Tbl. 15: Malfunctions PKR

Malfunction	LED		Possible cause	Remedy
	"ST"	"HV-ST"		
No voltage at signal output	Off	Off	No supply	Switch the supply on.
Measuring signal unstable	Lights up green	Lights up green	Gauge contaminated	Replace the ionization chamber or the complete measurement chamber.
Voltage at signal output 0.15 V (sensor error)	Lights up yellow	Off	Overpressure in the measurement chamber	1. Evacuate at < 1×10^{-2} hPa. 2. Switch the gauge off and back on (reset).
Voltage at signal output 1.2 V (underrange)	Lights up yellow	Flashes green	Gas discharge has not ignited	Wait until the gas discharge ignites (approx. 5 minutes with a pressure of 10^{-9} hPa).

Malfunction	LED		Possible cause	Remedy
	"ST"	"HV-ST"		
Voltage at signal output constantly < 0.3 V	Flashes red	Off	EEPROM error	Switch the gauge off, wait 5 seconds and then switch it back on (reset). Replace the gauge.
Signal constant with approx. 7.2 V (5×10^{-4} hPa).	Lights up green	Lights up green	Measurement chamber heavily contaminated	Replace the complete measurement chamber.

Tbl. 16: Malfunctions IKR

9.2 Identifying errors at the measurement chamber

If you are fairly certain of the cause of a measurement chamber malfunction, you can carry out an approximate diagnosis using an ohmmeter. Venting of the vacuum system is not necessary.

Prerequisite

- Electronic unit removed

Equipment required

- Ohmmeter

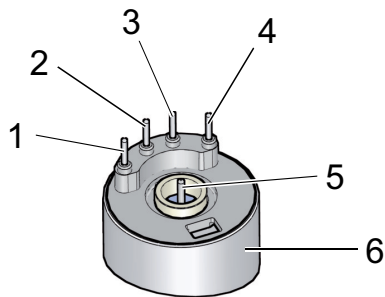

Fig. 20: Contact pins of the measurement chamber

1 – 5

Contact pin

6

Measurement chamber

Measurement between	Setpoint range	Reasons for values being outside of setpoint range
1 and 4	39.5 – 40.5 Ω (at 20 °C)	Faulty Pirani filament
1 and 2	1000 – 1100 Ω (at 20 °C)	Faulty Pirani temperature sensor
5 and 6	∞	Value $\ll \infty$: contamination, short circuiting of cold cathode

Tbl. 17: Measurement PKR

Measurement between	Setpoint range	Reasons for values being outside of setpoint range
5 and 6	∞	Value $\ll \infty$: contamination, short circuiting of cold cathode

Tbl. 18: Measurement IKR

Performing a resistance test

1. Perform the measurements at the contact pins of the measurement chamber using an ohmmeter.
2. Replace the complete measurement chamber if the measured value is outside of the setpoint range.

10 Shipping

WARNING

Risk of poisoning from contaminated products

Where products that contain harmful substances are shipped for maintenance or repair purposes, the health and safety of service personnel is at risk.

- ▶ Comply with the instructions for safe distribution.



Decontamination subject to charge

Pfeiffer Vacuum decontaminates products not clearly declared "Free of contamination" at your expense.

Ship product safely

- ▶ Do not ship microbiological, explosive or radioactively contaminated products.
- ▶ Observe the shipping guidelines for the participating countries and transport companies.
- ▶ Highlight any potential dangers on the outside of the packaging.
- ▶ Download the explanation for contamination at [Pfeiffer Vacuum Service](#).
- ▶ Always enclose a completed declaration of contamination.

11 Recycling and disposal

WARNING

Health hazard through poisoning from toxic contaminated components or devices

Toxic process media result in contamination of devices or parts of them. During maintenance work, there is a risk to health from contact with these poisonous substances. Illegal disposal of toxic substances causes environmental damage.

- ▶ Take suitable safety precautions and prevent health hazards or environmental pollution by toxic process media.
- ▶ Decontaminate affected parts before carrying out maintenance work.
- ▶ Wear protective equipment.



Environmental protection

You **must** dispose of the product and its components in accordance with all applicable regulations for protecting people, the environment and nature.

- Help to reduce the wastage of natural resources.
- Prevent contamination.



Environmental protection

The product and its components **must be disposed of in accordance with the applicable regulations relating to environmental protection and human health**, with a view to reducing natural resource wastage and preventing pollution.

11.1 General disposal information

Pfeiffer Vacuum products contain materials that you must recycle.

- ▶ Dispose of our products according to the following:
 - Iron
 - Aluminium
 - Copper
 - Synthetic
 - Electronic components
 - Oil and fat, solvent-free
- ▶ Observe the special precautionary measures when disposing of:
 - Fluoroelastomers (FKM)
 - Potentially contaminated components that come into contact with media

11.2 Dispose of gauges

Pfeiffer Vacuum gauges contain materials that you must recycle.

1. Dismantle the electronic unit.
2. Decontaminate the components that come into contact with process gases.
3. Separate the components into recyclable materials.
4. Recycle the non-contaminated components.
5. Dispose of the product or components in a safe manner according to locally applicable regulations.

12 Service solutions by Pfeiffer Vacuum

We offer first-class service

High vacuum component service life, in combination with low downtime, are clear expectations that you place on us. We meet your needs with efficient products and outstanding service.

We are always focused on perfecting our core competence – servicing of vacuum components. Once you have purchased a product from Pfeiffer Vacuum, our service is far from over. This is often exactly where service begins. Obviously, in proven Pfeiffer Vacuum quality.

Our professional sales and service employees are available to provide you with reliable assistance, worldwide. Pfeiffer Vacuum offers an entire range of services, from [original replacement parts](#) to [service contracts](#).

Make use of Pfeiffer Vacuum service

Whether preventive, on-site service carried out by our field service, fast replacement with mint condition replacement products, or repair carried out in a [Service Center](#) near you – you have various options for maintaining your equipment availability. You can find more detailed information and addresses on our homepage, in the [Pfeiffer Vacuum Service](#) section.

You can obtain advice on the optimal solution for you, from your [Pfeiffer Vacuum representative](#).

For fast and smooth service process handling, we recommend the following:



1. Download the up-to-date form templates.
 - [Explanations of service requests](#)
 - [Service requests](#)
 - [Contamination declaration](#)



- a) Remove and store all accessories (all external parts, such as valves, protective screens, etc.).
 - b) If necessary, drain operating fluid/lubricant.
 - c) If necessary, drain coolant.
2. Complete the service request and contamination declaration.



3. Send the forms by email, fax, or post to your local [Service Center](#).



4. You will receive an acknowledgment from Pfeiffer Vacuum.

PFEIFFER VACUUM

Submission of contaminated products

No microbiological, explosive, or radiologically contaminated products will be accepted. Where products are contaminated, or the contamination declaration is missing, Pfeiffer Vacuum will contact you before starting service work. Depending on the product and degree of pollution, **additional decontamination costs** may be incurred.

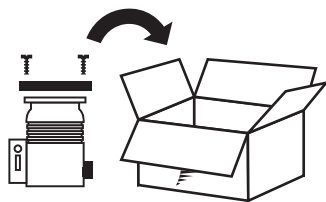

5. Prepare the product for transport in accordance with the provisions in the contamination declaration.
 - a) Neutralize the product with nitrogen or dry air.
 - b) Seal all openings with blind flanges, so that they are airtight.
 - c) Shrink-wrap the product in suitable protective foil.
 - d) Package the product in suitable, stable transport containers only.
 - e) Maintain applicable transport conditions.

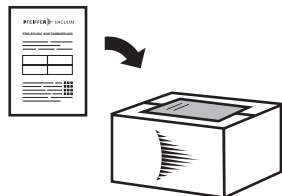

6. Attach the contamination declaration to the **outside** of the packaging.

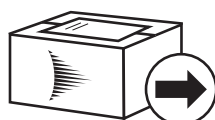

7. Now send your product to your local Service Center.



8. You will receive an acknowledgment/quotation, from Pfeiffer Vacuum.

PFEIFFER VACUUM

Our sales and delivery conditions and repair and maintenance conditions for vacuum devices and components apply to all service orders.

14 Accessories



View the [range of accessories for ActiveLine](#) on our website.

14.1 Accessory information

Measurement cable

Measurement cable in different lengths, for connecting to a Pfeiffer Vacuum total pressure measuring and control unit

Mating connector

Cable socket for fabrication of the application-specific connecting cable

Seals with centering ring and filter

Filter available in different pore sizes to protect the measuring system against contamination in the event of potential contaminating applications

14.2 Ordering accessories

Description	Order number
Measurement cable, 3 m	PT 448 250 -T
Measurement cable, 6 m	PT 448 251 -T
Measurement cable, 10 m ⁴⁾	PT 448 252 -T
Mating connector, 6 pole	B4707283MA
Centering ring with sintered metal filter, 20 µm pore size, FKM/stainless steel, DN 25 ISO-KF	PF 117 225 -T
Centering ring with sintered metal filter, 20 µm pore size, FKM/stainless steel, DN 40 ISO-KF	PF 117 240 -T

4) Further cable lengths are available up to 100 m.

15 Technical data and dimensions

15.1 General

	mbar	bar	Pa	hPa	kPa	Torr mm Hg
mbar	1	$1 \cdot 10^{-3}$	100	1	0.1	0.75
bar	1000	1	$1 \cdot 10^5$	1000	100	750
Pa	0.01	$1 \cdot 10^{-5}$	1	0.01	$1 \cdot 10^{-3}$	$7.5 \cdot 10^{-3}$
hPa	1	$1 \cdot 10^{-3}$	100	1	0.1	0.75
kPa	10	0.01	1000	10	1	7.5
Torr mm Hg	1.33	$1.33 \cdot 10^{-3}$	133.32	1.33	0.133	1

$$1 \text{ Pa} = 1 \text{ N/m}^2$$

Tbl. 20: Conversion table: Pressure units

	mbar l/s	Pa m ³ /s	sccm	Torr l/s	atm cm ³ /s
mbar l/s	1	0.1	59.2	0.75	0.987
Pa m ³ /s	10	1	592	7.5	9.87
sccm	$1.69 \cdot 10^{-2}$	$1.69 \cdot 10^{-3}$	1	$1.27 \cdot 10^{-2}$	$1.67 \cdot 10^{-2}$
Torr l/s	1.33	0.133	78.9	1	1.32
atm cm ³ /s	1.01	0.101	59.8	0.76	1

Tbl. 21: Conversion table: Units for gas throughput

15.2 Technical data

Parameter	Value
Measuring range (air, N ₂)	1×10^{-9} – 1000 hPa
Maximum pressure (absolute)	10 000 hPa, limited to inert gases and temperatures < 55°C
Burst pressure (absolute)	>13 000 hPa
Measuring principle	Pirani/cold cathode
Accuracy (N ₂)	approx. ±30% in the range 1×10^{-8} – 100 hPa approx. ±50 % in the range 100 – 1000 hPa
Repeatability (N ₂)	approx. ±5 % in the range 1×10^{-8} – 100 hPa

Tbl. 22: Measuring and pressure values PKR

Parameter	Value
Measuring range (air, N ₂)	1×10^{-9} – 1×10^{-2} hPa
Maximum pressure (absolute)	10 000 hPa, limited to inert gases and temperatures < 55°C
Burst pressure (absolute)	>13 000 hPa
Measuring principle	Cold cathode
Accuracy (N ₂)	approx. ±30% in the range 1×10^{-8} – 1×10^{-2} hPa
Repeatability (N ₂)	approx. ±5 % in the range 1×10^{-8} – 1×10^{-2} hPa

Tbl. 23: Measuring and pressure values IKR

Parameter		Value
Output signal (measuring signal)	Voltage range	approx. 0 V – +10.5 V DC
	Measuring range	1.397 – 8.6 V DC
	Error signal	9.5 – 10.5 V DC
	Relation voltage-pressure	logarithmic, lead 0.6 V DC/decade
Output impedance		2 × 4.7 Ω, short circuit-proof
Load impedance (minimum load)		≥10 kΩ, short-circuit proof
Response time		pressure-dependent
	p > 10 ⁻⁶ hPa	<100 ms
	p = 10 ⁻⁶ – 10 ⁻⁸ hPa	approx. 1 s
Gauge identification	Solely Pirani operation	Resistance 11.1 kΩ against supply earth
	Combined Pirani/cold cathodes operation	Resistance 9.1 kΩ against supply earth
	Conditions to be complied with in this regard: <ul style="list-style-type: none"> • The polarity of Pin 1 must always be positive against supply earth. • Measurements with constant current: Measurement current in the range of 0.2 – 0.3 mA • Measurements with constant voltage: Measurement voltage in the range 2 – 3 V DC 	
Supply voltage		Class 2/LPS
	At gauge ⁵⁾	14.5 – 30.0 V DC
	Ripple	max. 1 V _{pp}
Ignition voltage (in the measurement chamber)		≤4.5 kV
Operating voltage (in the measurement chamber)		≤3.3 kV
Operating current (in the measurement chamber)		PKR 360: Low current
		PKR 361: High current
Power consumption		≤2 W
Fuse (to be connected in series) ⁶⁾		≤ 1 AT
Connection (electrical)		Hirschmann GO 6 (6-pin, pins)
Measurement cable		5-pin, including shielding
Cable length		max. 75 m (0.14 mm ² /conductor)
		max. 100 m (0.34 mm ² /conductor)
		max. 300 m (1.0 mm ² /conductor)
Grounding concept	(see chapter “Establishing the electric connection”, page 23)	
	Vacuum connection and signal ground	connected with 10 kΩ (potential difference ≤ 16 V DC)
	Supply earth and signal earth	arranged separately, differential measurement recommended

Tbl. 24: Electrical data PKR

Parameter		Value
Output signal (measuring signal)	Voltage range	approx. 0 V – +10.5 V DC
	Measuring range	1.5 – 8.5 V DC
	Error signal	<0.5 V DC (no supply)
	Relation voltage-pressure	logarithmic, lead 1 V DC/decade
Output impedance		2 × 4.7 Ω, short circuit-proof
Load impedance (minimum load)		≥10 kΩ, short-circuit proof

5) Increase the minimum voltage for the supply unit proportional to the cable length.

6) Pfeiffer Vacuum measuring and control units comply with this requirement.

Parameter	Value	
Response time	pressure-dependent	
	$p > 10^{-6}$ hPa	<100 ms
	$p = 10^{-6} - 10^{-8}$ hPa	approx. 1 s
Gauge identification	Resistance 5.1 k Ω against supply earth	
	Conditions to be complied with in this regard: <ul style="list-style-type: none"> • The polarity of Pin 1 must always be positive against supply earth. • Measurements with constant current: Measurement current in the range of 0.2 – 0.3 mA • Measurements with constant voltage: Measurement voltage in the range 2 – 3 V DC 	
Supply voltage	Class 2/LPS	
	At gauge ⁷⁾	14.5 – 30.0 V DC
	Ripple	max. 1 V _{pp}
Ignition voltage (in the measurement chamber)	≤ 4.5 kV	
Operating voltage (in the measurement chamber)	≤ 3.3 kV	
Operating current (in the measurement chamber)	IKR 360: Low current	
	IKR 361: High current	
Power consumption	≤ 2 W	
Fuse (to be connected in series) ⁸⁾	≤ 1 AT	
Connection (electrical)	Hirschmann GO 6 (6-pin, pins)	
Measurement cable	5-pin, including shielding	
Cable length	max. 75 m (0.14 mm ² /conductor)	
	max. 100 m (0.34 mm ² /conductor)	
	max. 300 m (1.0 mm ² /conductor)	
Grounding concept	(see chapter "Establishing the electric connection", page 23)	
	Vacuum connection and signal ground	connected with 10 k Ω (potential difference ≤ 16 V DC)
	Supply earth and signal earth	arranged separately, differential measurement recommended

Tbl. 25: Electrical data IKR

Parameter	Value
Internal volume	approx. 19.9 cm ³ (DN 25 ISO-KF)
	approx. 20.9 cm ³ (DN 40 ISO-KF)
	approx. 25.2 cm ³ (DN 40 CF-F)
Weight	<280 g (DN 25 ISO-KF)
	<320 g (DN 40 ISO-KF)
	<570 g (DN 40 CF-F)

Tbl. 26: Internal volume and weight

Parameter	Value	
Relative humidity of air (for 30 days of the year)	$1 \times 10^{-8} - 1 \times 10^{-2}$ hPa	≤ 70 % (non-condensing)
	$1 \times 10^{-7} - 1 \times 10^{-2}$ hPa	≤ 95 % (non-condensing)
Mounting orientation	Arbitrary	

7) The minimum voltage for the supply unit must be increased proportional to the cable length.

8) Pfeiffer Vacuum measuring and control units comply with this requirement.

Parameter	Value
Usage	Only in indoor areas
Installation altitude max.	6000 m above sea level
Protection degree	IP40

Tbl. 27: Ambient conditions

Parameter	Value
Operation	5 – 55 °C
Pirani filament (PKR only)	120 °C
Storage	-40 – +70 °C
Bake out	≤150°C ⁹⁾

Tbl. 28: Temperatures

Parameter	Value
Flange	Stainless steel (1.4435)
Measurement chamber	Stainless steel (1.4435)
Pirani filament (PKR only)	Tungsten (W)
Feedthrough (insulation)	Ceramic (Al ₂ O ₃), glass
Feedthrough (ring)	Stainless steel (1.4435)
Feedthrough (anode)	Molybdenum (Mo)
Feedthrough (pin)	Nickel alloy (Ni)
Feedthrough (PKR 36x C, IKR 36x C)	Ceramic coated
Ionization chamber	Stainless steel (1.4301, 1.4016)
Ignition aid	Stainless steel (1.4310)

Tbl. 29: Substances in contact with the media

9) Without electronic unit

15.3 Dimensions

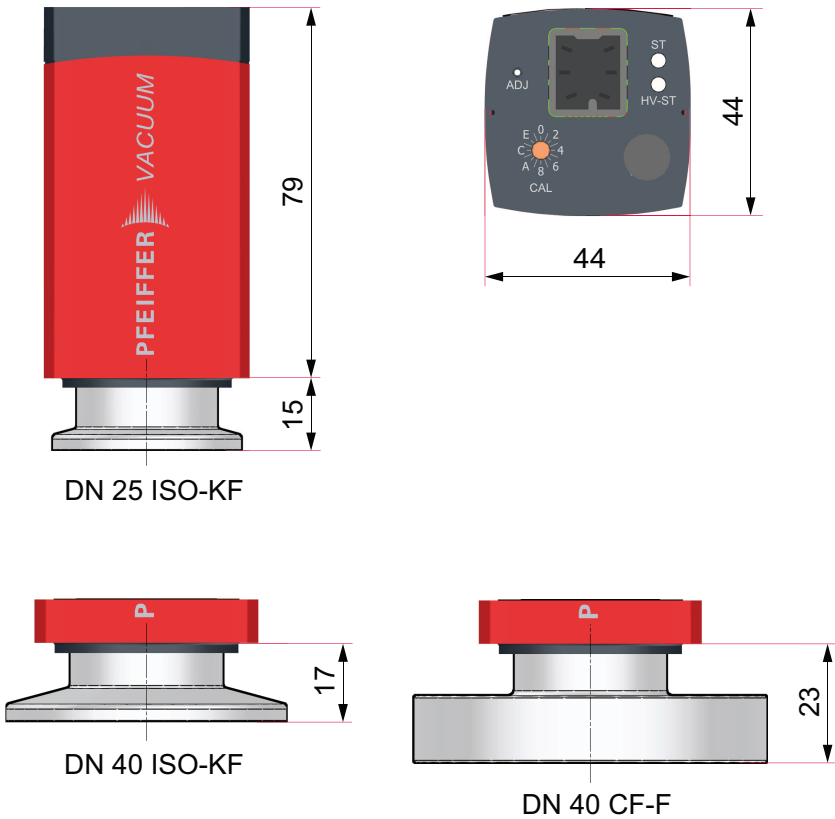

Fig. 22: Dimensions
Dimensions in mm.



Intertek
3103457

ETL LISTED

The products PKR 360, PKR 360 C, PKR 361 and PKR 361C

- conform to the UL standard
UL 61010-1.

- are certified to the CAN/CSA standard
CAN/CSA C22.2 No. 61010-1-12.



ETL LISTED

The products IKR 360, IKR 360 C, IKR 361 and IKR 361C

- conform to the UL standard
UL 61010-1.

- are certified to the CAN/CSA standard
CAN/CSA C22.2 No. 61010-1-12.

Declaration of Conformity

Declaration for product(s) of the type:

Pirani/cold cathode gauge

PKR 360
PKR 360 C
PKR 361
PKR 361 C

We hereby declare that the listed product satisfies all relevant provisions of the following **European Directives**.

Electromagnetic compatibility 2014/30/EU

Restriction of the use of certain hazardous substances 2011/65/EU

Restriction of the use of certain hazardous substances, delegated directive 2015/863/EU

Harmonized standards and applied national standards and specifications:

DIN EN IEC 61000-6-2:2019-11
DIN EN IEC 61000-6-3:2022-06
DIN EN 61010-1:2020-03
DIN EN 61326-1:2013-07

Signature:



(Daniel Sälzer)
Managing Director

Pfeiffer Vacuum GmbH
Berliner Straße 43
35614 Asslar
Germany

Asslar, 2022-07-01



Declaration of Conformity

Declaration for product(s) of the type:

Cold cathode gauge

IKR 360
IKR 360 C
IKR 361
IKR 361 C

We hereby declare that the listed product satisfies all relevant provisions of the following **European Directives**.

Electromagnetic compatibility 2014/30/EU

Restriction of the use of certain hazardous substances 2011/65/EU

Restriction of the use of certain hazardous substances, delegated directive 2015/863/EU

Harmonized standards and applied national standards and specifications:

DIN EN IEC 61000-6-2:2019-11
DIN EN IEC 61000-6-3:2022-06
DIN EN 61010-1:2020-03
DIN EN 61326-1:2013-07

Signature:



(Daniel Sälzer)
Managing Director

Pfeiffer Vacuum GmbH
Berliner Straße 43
35614 Asslar
Germany

Asslar, 2022-07-01



VACUUM SOLUTIONS FROM A SINGLE SOURCE

Pfeiffer Vacuum stands for innovative and custom vacuum solutions worldwide, technological perfection, competent advice and reliable service.

COMPLETE RANGE OF PRODUCTS

From a single component to complex systems:

We are the only supplier of vacuum technology that provides a complete product portfolio.

COMPETENCE IN THEORY AND PRACTICE

Benefit from our know-how and our portfolio of training opportunities!

We support you with your plant layout and provide first-class on-site service worldwide.

ed. C - Date 2207 - P/N:BG5164BEN



Are you looking for a
perfect vacuum solution?
Please contact us

Pfeiffer Vacuum GmbH
Headquarters • Germany
T +49 6441 802-0
info@pfeiffer-vacuum.de

www.pfeiffer-vacuum.com

PFEIFFER  **VACUUM**