



# MAINTENANCE INSTRUCTIONS

EN

Translation of the Original

## ASM 390 - ASM 392

Leak detector

**PFEIFFER**  **VACUUM**

---

## Disclaimer of liability

These operating instructions describe all models and variants of your product. Note that your product may not be equipped with all features described in this document. Pfeiffer Vacuum constantly adapts its products to the latest state of the art without prior notice. Please take into account that online operating instructions can deviate from the printed operating instructions supplied with your product.

Furthermore, Pfeiffer Vacuum assumes no responsibility or liability for damage resulting from the use of the product that contradicts its proper use or is explicitly defined as foreseeable misuse.

## Copyright

This document is the intellectual property of Pfeiffer Vacuum and all contents of this document are protected by copyright. They may not be copied, altered, reproduced or published without the prior written permission of Pfeiffer Vacuum.

We reserve the right to make changes to the technical data and information in this document.

# Table of contents

<b>1</b>	<b>About this manual</b>	<b>4</b>
1.1	Validity	4
	1.1.1 Applicable documents	4
	1.1.2 Products concerned	4
1.2	User target group	4
1.3	Conventions	4
	1.3.1 Instructions in the text	4
	1.3.2 Pictographs	4
	1.3.3 Labels	5
<b>2</b>	<b>Safety</b>	<b>7</b>
2.1	General safety information	7
	2.1.1 Safety instructions	7
	2.1.2 Precautions	9
<b>3</b>	<b>General information</b>	<b>10</b>
3.1	Spare parts	10
3.2	Precautions	10
3.3	Preparatory work	11
<b>4</b>	<b>Maintenance intervals and responsibilities</b>	<b>12</b>
<b>5</b>	<b>Service - Maintenance</b>	<b>13</b>
5.1	Cleaning	13
5.2	Detector powering off	13
5.3	Work plan disassembly/reassembly	13
5.4	Front cover disassembly/reassembly	14
5.5	Internal calibrated leak replacement	15
5.6	Analyzer cell maintenance	16
	5.6.1 Analyzer cell disassembly/reassembly	16
	5.6.2 Seal replacement	18
	5.6.3 Filament replacement	18
5.7	Fan maintenance	19
	5.7.1 Fan location	20
	5.7.2 Air inlet fan (V1) replacement	20
	5.7.3 Exhaust fan (V2) replacement	20
5.8	Filter maintenance	21
	5.8.1 Vacuum block air filter replacement	21
	5.8.2 Air inlet filter replacement	22
5.9	Pirani gauge replacement	22
<b>6</b>	<b>Decommissioning</b>	<b>24</b>
6.1	Shutting down for longer periods	24
6.2	Disposal	24
	6.2.1 Restriction of Hazardous Substances (RoHS)	24
	6.2.2 Electrical and Electronic Equipment (EEE)	24
<b>7</b>	<b>Malfunctions</b>	<b>26</b>
7.1	Operation monitoring	26
7.2	Fault display	26
<b>8</b>	<b>Service solutions by Pfeiffer Vacuum</b>	<b>27</b>
<b>9</b>	<b>Spare parts</b>	<b>29</b>
9.1	Tools	29
9.2	Leak detector spare parts	30
9.3	Accessories	32

# 1 About this manual



**IMPORTANT**

Read carefully before use.  
Keep the manual for future consultation.

## 1.1 Validity

This maintenance manual is intended for customers of Pfeiffer Vacuum. It describes the maintenance procedures that the customer can perform on the respective product. **This document has to be used in conjunction with the operating instructions of the product with the same name.**

### 1.1.1 Applicable documents

Document	Part Number
ASM 390/392 Operating instructions	126348*
* also available at <a href="http://www.pfeiffer-vacuum.com">www.pfeiffer-vacuum.com</a>	

### 1.1.2 Products concerned

This document applies to products with the following part numbers:

Part Number	Description
CSGB01GxMM9x	ASM 390
ESGB02GxMM9x	ASM 392

## 1.2 User target group

This maintenance manual is intended for all persons responsible for product maintenance, for the following operations:

- disassembly
- maintenance
- cleaning

The work described in this document must **only** be carried out by persons with suitable technical training (e.g. maintenance technicians) and have completed the necessary training as provided by Pfeiffer Vacuum.

## 1.3 Conventions

### 1.3.1 Instructions in the text

Usage instructions in the document follow a general structure that is complete in itself. The required action is indicated by an individual step or multi-part action steps.

**Individual action step**

A horizontal, solid triangle indicates the only step in an action.

- ▶ This is an individual action step.







**Sequence of multi-part action steps**

The numerical list indicates an action with multiple necessary steps.

1. Step 1
2. Step 2
3. ...







### 1.3.2 Pictographs

Pictographs used in the document indicate useful information.

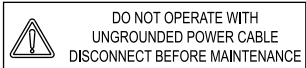
-  Note
-  Tip
-  Check a key point on the graphic.
-  Apply the stated tightening torque.
-  Respect the chronological order of operations and/or assembly/disassembly direction.
-  Correct, right choice.
-  Incorrect, wrong choice.

### 1.3.3 Labels

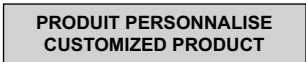
<b>INPUTS/OUTPUTS</b>	Inputs/Outputs communication interface connector
<b>SERIAL</b>	9-pin D-Sub RS-232 serial link connector
<b>NETWORK</b>	Ethernet plug
<b>USB</b>	USB plug

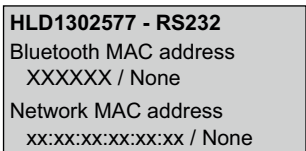
- 1  This label guarantees to the user that the product packaging has not been opened since leaving the factory.
- 2  This label indicates that some of the internal parts are electrically live and could cause electrical shock in case of contact.
  - Do not use the product if the main power supply cable is not earthed.
  - Disconnect the main power supply cable from the product before servicing the product.
- 3  This label indicates that some of the internal parts are electrically live and could cause electrical shock in case of contact.
  - Disconnect the main power supply cable from the product before removing the cover.
- 4  This label indicates that the detector's exhaust should not be blocked.
- 5  This label indicates the grounding point on the product.
- 6  This label indicates that the product has been customized at the customer's request.
- 7  This label indicates that the product has been certified compliant with quality control upon leaving the factory.
- 8  This label indicates that the product is subject to regulations for the treatment of electrical and electronic equipment waste (refer to the EC declaration of conformity for the product).
- 9  This label indicates the MAC address for the options installed in the product.

(Example)

10

Pu_GL : 1	Pu_N : 1
Mu_GL : 12856	Mu_N : 31
.....	
Mu_Cal : 1	Mu_LDS : 1800

For service centers use only

(Example)

11

DD-MM-YY④		
<b>Factory Firmware /Logiciel usine</b>		
L0232	V3302	E17D
L0264	V3200	FD87E7D
L0285	V3200	8C9D
①	②	③

This label provides information regarding firmware installed in the product.

- |   |                  |   |                   |
|---|------------------|---|-------------------|
| 1 | Firmware name    | 3 | Firmware checksum |
| 2 | Firmware version | 4 | Publication date  |

(Example)

12

<b>PFEIFFER</b> VACUUM		CE	
98 avenue de Brogny F-74000 ANNECY Made in France			
1	Kg	2	V
		3	Hz
		4	W
P/N :	5		6
S/N :	7	8	
			

Product rating plate.

- |   |                           |   |                     |
|---|---------------------------|---|---------------------|
| 1 | Weight                    | 5 | Part Number         |
| 2 | Use voltage               | 6 | Description         |
| 3 | Use frequency             | 7 | Serial number       |
| 4 | Maximum power consumption | 8 | Date of manufacture |

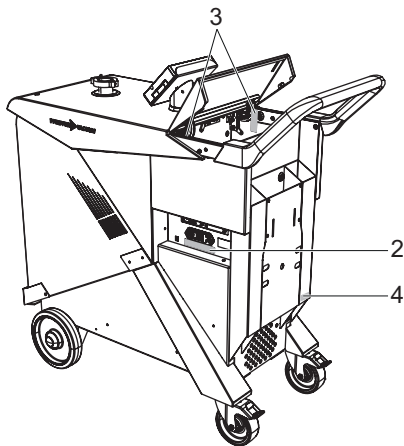

## 2 Safety

### 2.1 General safety information

The following 4 risk levels and 1 information level are taken into account in this document.

#### **DANGER**

##### **Immediately pending danger**

Indicates an immediately pending danger that will result in death or serious injury if not observed.

- ▶ Instructions to avoid the danger situation

#### **WARNING**

##### **Potential pending danger**

Indicates a pending danger that could result in death or serious injury if not observed.

- ▶ Instructions to avoid the danger situation

#### **CAUTION**

##### **Potential pending danger**

Indicates a pending danger that could result in minor injuries if not observed.

- ▶ Instructions to avoid the danger situation

#### **NOTICE**

##### **Danger of damage to property**

Is used to highlight actions that are not associated with personal injury.

- ▶ Instructions to avoid damage to property



Notes, tips or examples indicate important information about the product or about this document.

#### 2.1.1 Safety instructions

All safety instructions in this document are based on the results of the risk assessment carried out in accordance with Low-Voltage Directive 2014/35/EU regarding electrical safety. Where applicable, all life cycle phases of the product were taken into account.

#### **WARNING**

##### **Risk of electric shock due to non-compliant electrical installations**

This product uses mains voltage for its electrical supply. Non-compliant electrical installations or installations not done to professional standards may endanger the user's life.

- ▶ Only qualified technicians trained in the relevant electrical safety and EMC regulations are authorized to work on the electrical installation.
- ▶ This product must not be modified or converted arbitrarily.

#### **WARNING**

##### **Risk of electric shock in case of contact with products that are not electrically isolated**

When powering off \_mains switch to **O**\_, certain components located between the mains connection and the circuit breaker will still contain an electric charge (live). There is a risk of electric shock in case of contact.

- ▶ Make sure that the mains connection is always visible and accessible so that it can be unplugged at any time.
- ▶ Disconnect the mains cable from the electrical network before working on the product.
- ▶ Wait for the control panel screen to turn off completely before working on the product and/or removing the cover(s).

**⚠ WARNING**

**Risk of serious injury due to falling objects**

When transporting parts/components and during product maintenance, there is a danger of injury caused by loads slipping or falling.

- ▶ Carry small and medium-size components with both hands.
- ▶ Transport components that weigh more than 20 kg using suitable lifting gear.
- ▶ Wear safety shoes with steel toes in accordance with directive EN 347.

**⚠ WARNING**

**Risk of burns in case of contact with hot surfaces**

For the operator's safety, the products are designed to avoid thermal risk. However, specific operating conditions may exist that require extra caution on the part of the operator due to the high temperatures (surfaces > 70 °C for parts inside the cover(s)).

- ▶ Wait for the product to fully cool down before working on it.
- ▶ Protective gloves must be worn in accordance with standard EN ISO 21420.

**⚠ CAUTION**

**Risk of pinching when handling the storage box cover**

- ▶ Be careful not to leave your fingers under the cover when closing.

**⚠ DANGER**

**Health hazard in case of contact with components contaminated**

The components of the pumping circuit and the analyzer cell are contaminated with the gases pumped through the tested parts. These gases may be toxic, corrosive and/or reactive. Any contact with the contaminated parts or by-products generated by the process may be injurious to health.

- ▶ Wear appropriate protective equipment when performing maintenance on the components of the pumping line, vacuum block and analyzer cell.
- ▶ Ventilate the area thoroughly or carry out the maintenance under an extraction hood.
- ▶ Do not eliminate the by-products/residue as common waste; have them destroyed by a qualified company where necessary.

**⚠ WARNING**

**Poisoning risk in case of gas leakage after maintenance**

When connecting/disconnecting pumping line components (pumps, analyzer cell, vacuum block, pipework, valves, etc.) for maintenance, the tightness of the installation is broken, potentially causing leakage of hazardous residual gases (pumped gases for parts to be tested).

- ▶ During disassembly, always protect the bearing surfaces of the connecting flanges between the pumping line components.
- ▶ After reassembly, perform a tightness check on the pumping line of the detection system.

**⚠ WARNING**

**Risk linked to the various energy sources**

Electrical circuit and other pressurized circuits as nitrogen are potential hazards.

- ▶ Always lock these sources of energy before working on the product.

**⚠ WARNING**

**Risk linked to installation tightness**

When the product leaves the factory, product tightness under normal operating conditions is guaranteed.

- ▶ Perform a tightness test after all maintenance operations.

### General maintenance recommendations

- When you order spare parts, you must mention everything featured on the product rating plate.
- Comply with all safety and risk prevention instructions in accordance with local safety standards.
- Wait 5 minutes after powering off before working on the electrical components.
- Regularly check compliance with all precautionary measures.
- Do not switch on the product without the covers.
- Fill in the declaration of contamination form available on our website. Attach it to the product before shipping to one of our Pfeiffer Vacuum service centers.
- Use the original packaging to return the product to a Pfeiffer Vacuum service center: the manufacturer shall not be held liable for damage resulting from transport in unsuitable packaging.

## 2.1.2 Precautions



### Duty to provide information on potential dangers

The product holder or user is obliged to make all operating personnel aware of dangers posed by this product.

Every person who is involved in the installation, operation or maintenance of the product must read, understand and adhere to the safety-related parts of this document.



### Obligation to provide personal protective equipment

The operators or employers are obliged to provide the user of the product with the necessary personal protective equipment (PPE).

Persons responsible for installing, operating and repairing the product must wear PPE for safety.



### Infringement of conformity due to modifications to the product

The Declaration of Conformity from the manufacturer is no longer valid if the operator changes the original product or installs additional equipment.

- Following the installation into a system, the operator is required to check and re-evaluate the conformity of the overall system in the context of the relevant European Directives, before commissioning that system.



### Installation and use of the accessories

The products can be fitted with special accessories.

The installation, use and refurbishment of the connected accessories are described in detail in the respective operating instructions.

- Only use original accessories.
- Accessory part numbers (see chapter "Accessories").

Only qualified personnel trained in safety regulations (EMC, electrical safety, chemical pollution) are authorized to carry out the installation and maintenance described in this manual. Our service centers can provide the necessary training.

- ▶ Do not remove the blanked-off flange from the inlet port while the product is not in use.
- ▶ Do not expose any part of the human body to the vacuum.
- ▶ Follow the safety and accident prevention requirements.
- ▶ Regularly check compliance with all precautionary measures.
- ▶ Do not turn on the product if the cover is not in place.
- ▶ Do not move the product while it is in use (product powered on).
- ▶ Use the product's brakes to immobilize it during use (product powered on).

## 3 General information

### 3.1 Spare parts



#### Replacement of defective parts

The initial safety conditions of the product call into question if non-original parts are used.

- Use only spare parts available for order from Pfeiffer Vacuum Service ([see chapter "Spare parts", page 29](#)).
- To identify the product and communicate with Pfeiffer Vacuum look at the product's rating plate.

### 3.2 Precautions



#### Duty to provide information on potential dangers

The product holder or user is obliged to make all operating personnel aware of dangers posed by this product.

Every person who is involved in the installation, operation or maintenance of the product must read, understand and adhere to the safety-related parts of this document.



#### Infringement of conformity due to modifications to the product

The Declaration of Conformity from the manufacturer is no longer valid if the operator changes the original product or installs additional equipment.

- Following the installation into a system, the operator is required to check and re-evaluate the conformity of the overall system in the context of the relevant European Directives, before commissioning that system.



#### Obligation to provide personal protective equipment

The operators or employers are obliged to provide the user of the product with the necessary Personal Protective Equipment (PPE).

Persons responsible for installing, operating and repairing the product must wear PPE for safety.



#### Installation and use of the accessories

The products can be fitted with special accessories.

The installation, use and refurbishment of the connected accessories are described in detail in the respective operating instructions.

- Only use original accessories.
- Accessory part numbers (see chapter "Accessories").

Only qualified personnel trained in safety regulations (EMC, electrical safety, chemical pollution) are authorized to carry out the installation and maintenance described in this manual. Our service centers can provide the necessary training.

- ▶ Do not remove the blanking plate from the inlet pipe while the product is not in use.
- ▶ Do not expose any part of the human body to the vacuum.
- ▶ Do not turn on the product if the cover is not in place (unless otherwise stated).
- ▶ Do not move the product while it is in use (product powered on).
- ▶ Follow the safety and accident prevention requirements.
- ▶ Regularly check compliance with all precautionary measures.
- ▶ Use the product brakes to immobilize it during use (product powered on).

### 3.3 Preparatory work

The detector does not require any maintenance at the customer's premises, except for the sub-assembly maintenance described in this manual. All other maintenance must be carried out by our service center (see chapter "Service solutions by Pfeiffer Vacuum", page 27).

#### **NOTICE**

##### **Damage to the equipment if a detector is handled while switched on**

If it is necessary to move or work on the product, the user must first make sure that the detector is fully shut down, otherwise there is a risk of damage to some of the detector components. When the main switch/circuit breaker is set to **O**:

- ▶ Unplug the power cable.
- ▶ Wait 5 minutes after power-off before working on the product.

#### **Procedure**

To ensure the proper operation of the detector after on-site maintenance, follow the recommendations provided below:

- ▶ Handle the detector so it can be moved in the maintenance area (see chapter "Handling" of the Operating instructions.)
  - Clean, dust-free room.
- ▶ Wear suitable protective equipment.
- ▶ Use the recommended tools for each maintenance operation.
  - If necessary, a maintenance set is available to order (see chapter "Tools").
- ▶ Always protect the surfaces of connecting flanges (analyzer cell, pumps and pipework).
- ▶ After reassembly, perform a leak test on the replaced sub-assembly.

## 4 Maintenance intervals and responsibilities

Maintenance operations for levels 1 and 2 of the interval table are described in this manual.

Level 3 overhaul operations require a technician from the Pfeiffer Vacuum Service network.

Operation	Frequency	Level <sup>1)</sup>	Site <sup>2)</sup>
<b>ACP 40 backing pump</b>			
Pump replacement	20,000 hours or 4 years	3	OS
<b>SplitFlow 80 turbomolecular pump</b>			
Oil reservoir replacement	4 years	3	OS
Ball bearing replacement	4 years	3	OS
TC 110 electronic drive unit replacement	As needed	3	OS
Pump replacement	As needed	3	OS
<b>HiPace 80 turbomolecular pump</b>			
Oil reservoir replacement	4 years	3	OS
Ball bearing replacement	4 years	3	OS
TC 110 electronic drive unit replacement	As needed	3	OS
Pump replacement	As needed	3	OS
<b>Analyzer cell</b>			
Seal replacement	As needed	2	OS
Filament replacement	As needed	2	OS
Overhaul of analyzer cell	As needed	3	OS
<b>Valves</b>			
Replacement of all solenoid valves	500,000 tests	3	OS
Depression valve seal replacement	500,000 tests	3	OS
Depression valve replacement	As needed	3	OS
<b>Air inlet filter</b>			
Replacement of the fan air filter	According to condition of operation	2	OS
<b>Pirani gauge</b>			
Adjustment	According to condition of operation Every 4,300 hours (recommended)	1	OS
Gauge replacement	As needed	2	OS
<b>Fan</b>			
Fan replacement	As needed	2	OS
<b>Calibrated leak</b>			
Recalibration	Every 2 years (recommended)	2	OS
<b>Leak detector</b>			
Overhaul of the detector	According to conditions of operation Every 4 years recommended	3	OS/WS
1) Maintenance level	2) Maintenance site		
<ul style="list-style-type: none"> <li>• 1: Operator</li> <li>• 2: Technician with Pfeiffer Vacuum training</li> <li>• 3: Pfeiffer Vacuum service technician</li> </ul>	<ul style="list-style-type: none"> <li>• OS: on customer site</li> <li>• WS: Pfeiffer Vacuum service center</li> </ul>		

### Maintenance time monitoring

The primary pump, the turbomolecular pump and the valve maintenance counters alert the operator that a maintenance operation must be performed (see chapter "Timers before next maintenance" of the operating instructions).



### How to contact us

Product overhauls must be carried out by personnel with manufacturer training. Contact our nearest service center at the following e-mail address: [Pfeiffer Vacuum Service Support](mailto:Pfeiffer_Vacuum_Service_Support).

## 5 Service - Maintenance

### 5.1 Cleaning

- ▶ Clean the cover(s) with a soft, lint-free cloth and a product that will not damage the paint, painted surfaces or the labels.

### 5.2 Detector powering off

1. Set the switch/circuit breaker to **O**.
2. Disconnect the mains power cable.
3. Wait 5 minutes before working on the detector, removing the cover or moving the detector.

#### Pump stop due to power failure

When there is a mains power failure, the detector shuts down: it switches on again automatically when power is restored.

### 5.3 Work plan disassembly/reassembly

#### Prerequisites for disassembly

- ▶ Immobilize the leak detector by setting the brakes on the rear wheels.
- ▶ Power off the leak detector (see chapter "Powering Off").

#### Disassembly

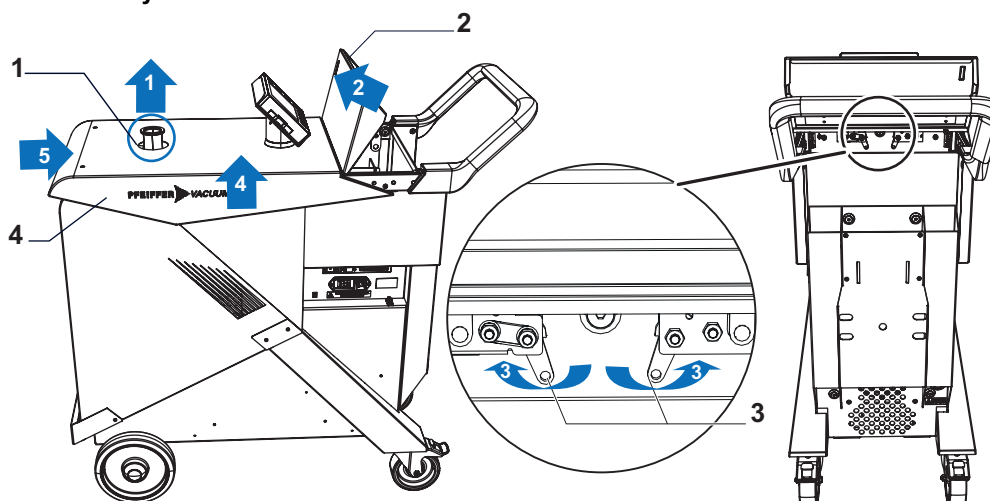

- |               |             |
|---------------|-------------|
| 1 Inlet pipe  | 3 Latch     |
| 2 Storage box | 4 Work plan |

1. Remove the flange around the inlet pipe.
2. Lift the cover of the storage box.
3. Operate each latch to unlock the work plan.
4. Carefully lift the work plan.
5. Push the work plan towards the rear of the detector then remove it.



The work plan can be removed without disconnecting the control panel as the cable is sufficiently long.

When the work plan has been removed from the detector, the operator must never perform mechanical actions on the calibrated leak or any other of the detector internal sub-assemblies.

#### Prerequisites for reassembly

- ▶ Power off the leak detector (see chapter "Powering Off").

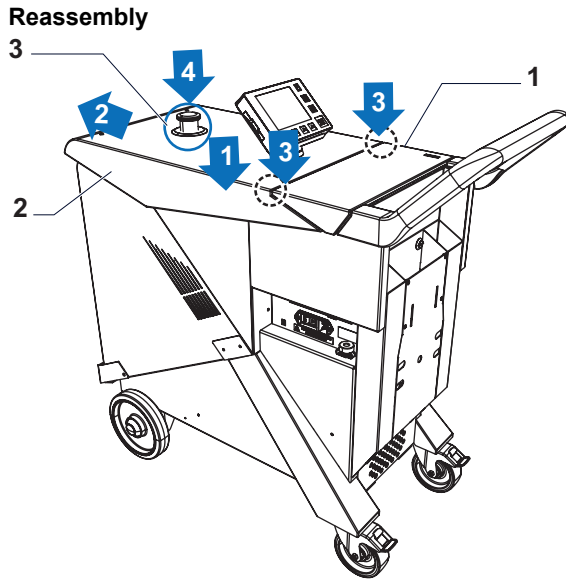

- 1 Storage box
- 2 Work plan
- 3 Inlet pipe

1. Place the work plan vertically on the frame.
2. Check that the control panel cable is clear: the control panel must be able to move at least 1 m from its support.
3. Pull the work plan towards the front of the detector then clip it on.
4. Refit the flange around the inlet pipe.

## 5.4 Front cover disassembly/reassembly

### Prerequisite for disassembly

- ▶ Disassemble the work plan (see chapter "Work plan disassembly/reassembly").

### Disassembly

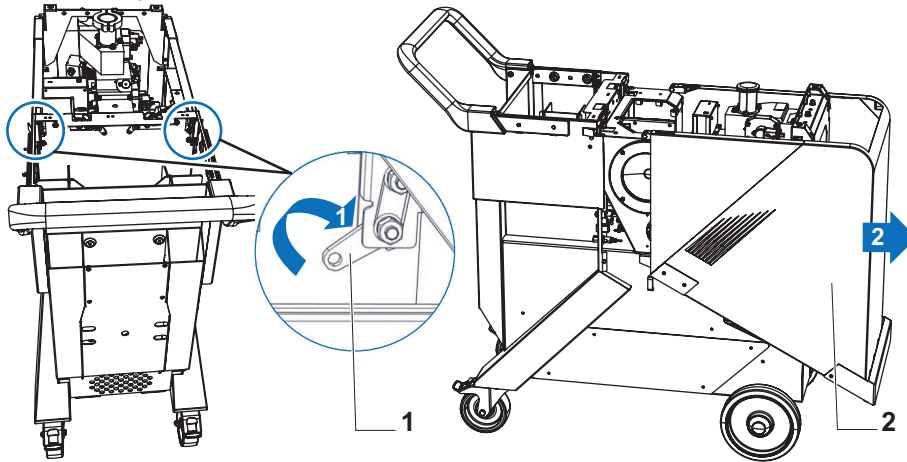

- 1 Latch
- 2 Cover

1. Operate each latch to unlock the cover.
2. Pull the cover forwards.

### Prerequisite for reassembly

- ▶ Power off the leak detector (see chapter "Powering Off").

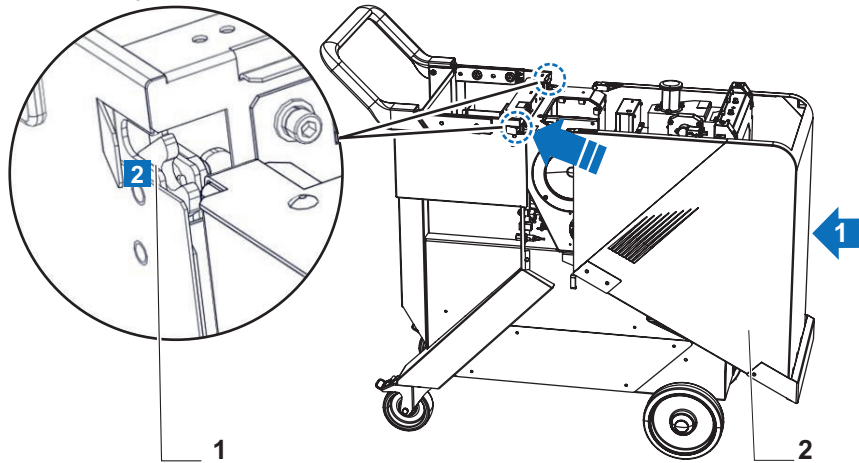
**Reassembly**

1 Latch                      2 Cover

1. Position the front cover on the frame and push it towards the front of the detector to clip it into the housing of each latch.
2. Check that the control panel cable is clear: the control panel must be able to move at least 1 m from its support.
3. Reassemble the work plan (see chapter "Work plan disassembly/reassembly").

## 5.5 Internal calibrated leak replacement

**Prerequisites**

- ▶ Power off the leak detector (see chapter "Powering Off").
- ▶ Remove the work plan (see chapter "Work plan disassembly/reassembly") and the front cover (see chapter "Front cover disassembly/reassembly").

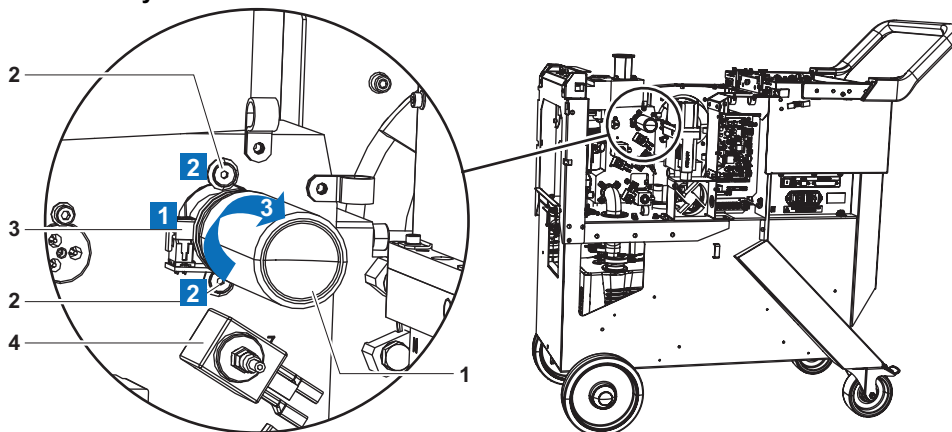
**Disassembly**

1 Calibrated leak                      3 Temperature sensor  
2 Fixing screws                      4 Valve

1. Disconnect the temperature sensor from the calibrated leak. Never separate the temperature sensor from the calibrated leak.
2. Loosen the 2 fixing screws without removing them.
3. Rotate the calibrated leak by 90° so that the temperature sensor is positioned above the valve as shown in the illustration.

**Reassembly**

1. Replace the calibrated leak.
2. Connect the temperature sensor.

3. Update the settings of the calibrated leak (see chapter “Spectro Menu” in the Operating Instructions).
4. Perform a calibration on the detector.

Every time a calibrated leak is replaced, update the calibrated leak setting (see chapter “Calibrated leak setting” in the Operating Instructions).

This operation can be carried out with the information featured on the calibrated leak rating plate or the calibrated leak certificate supplied with the leak.

**Example of calibrated leak rating plate**

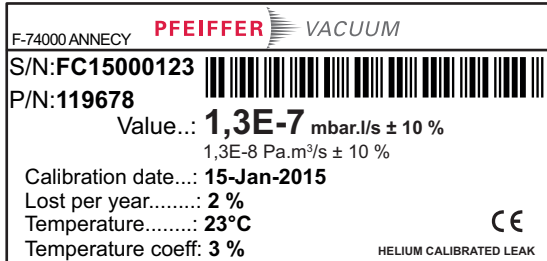

**Tightness test after calibrated leak maintenance**

- ▶ Open the calibration valve to carry out the test.
- ▶ Spray a light flow of helium 4 around the calibrated leak.
  - leak rate measured <math>< 1 \cdot 10^{-8} \text{ mbar}\cdot\text{l/s}</math> (

## 5.6 Analyzer cell maintenance



**Pollution of vacuum circuit components**

During maintenance operations for vacuum circuit components, avoid any contamination which could subsequently result in the degassing of the parts. Special caution must be exercised to ensure cleanliness. To avoid this:

- Perform the maintenance in an appropriate area (clean, dust-free and ventilated).
- Use non-woven materials.
- Dust the parts with filtered dry air (unless otherwise stated).
- Wear unpowdered vinyl gloves (clean room gloves).

### 5.6.1 Analyzer cell disassembly/reassembly

**⚠ WARNING**

**Risk of burns in case of contact with hot surfaces**

For the operator’s safety, the products are designed to avoid thermal risk. However, specific operating conditions may exist that require extra caution on the part of the operator due to the high temperatures (surfaces > 70 °C for parts inside the cover(s)).

- ▶ Wait for the product to fully cool down before working on it.
- ▶ Protective gloves must be worn in accordance with standard EN ISO 21420.

**Prerequisite condition(s) for the analyzer cell disassembly**

1. Make an air inlet on the vacuum circuit (see chapter “Secondary pump and analyzer cell maintenance” of the Operating instructions).
2. Power off the leak detector (see chapter “Powering Off”).
3. Remove the work plan (see chapter "Work plan disassembly/reassembly") and the front cover (see chapter "Front cover disassembly/reassembly").

### Analyzer cell disassembly

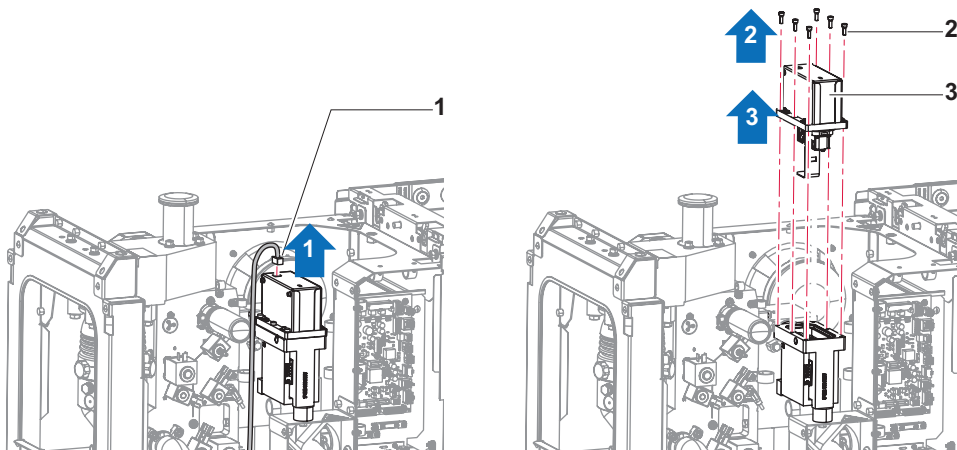

- 1 Harness                      3 Analyzer cell  
2 Fixing screws

1. Disconnect the harness from the cell.
2. Remove the cell's 6 fixing screws.
3. Free the analyzer cell manually and vertically.

### Analyzer cell reassembly

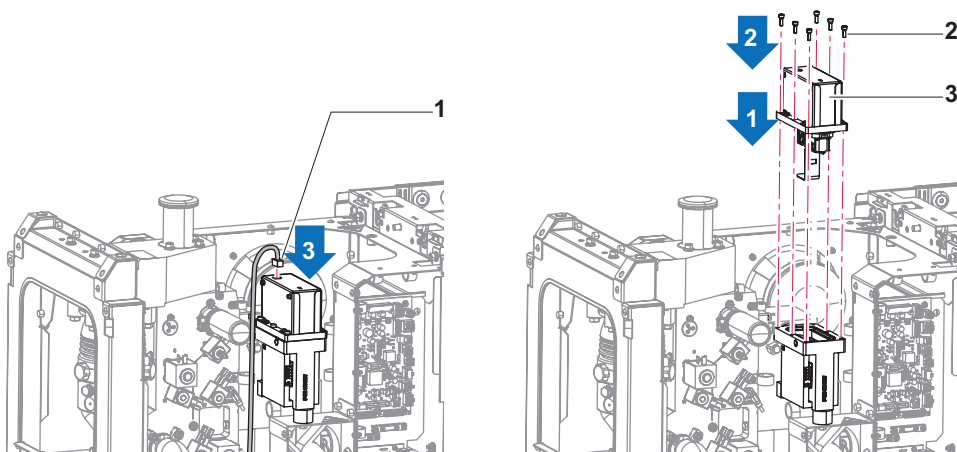

- 1 Harness                      3 Analyzer cell  
2 Fixing screws



#### Distortion of the measurement results with non-compliant analyzer cell

When it leaves the factory, the analyzer cell is set for the product in which it is installed.

The use of an analyzer cell different from the original component requires settings. Without these settings, the measurements made by the product are not correct. Only a Pfeiffer Vacuum service center can make these settings.

### Tightness test after analyzer cell reassembly

- ▶ Spray a light flow of helium 4 around the analyzer cell.
  - leak rate measured  $< 3 \cdot 10^{-10}$  mbar·l/s ( $3 \cdot 10^{-11}$  Pa·m<sup>3</sup>/s).

### 5.6.2 Seal replacement

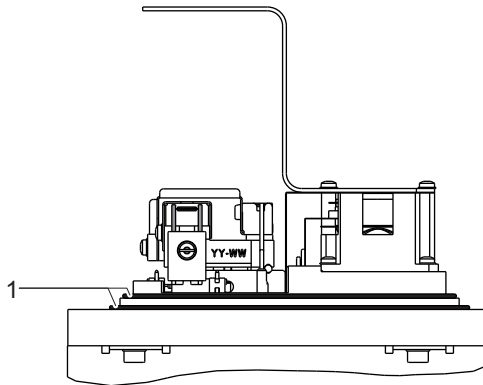

1 Seals

1. Remove the detector analyzer cell (see chapter “Disassembly/reassembly of the analyzer cell”).
2. Check the condition of the seals: change them if necessary.
3. Replace the 2 seals. **Never lubricate the seals.**

### 5.6.3 Filament replacement

NOTICE

**Distortion of product performance due to damaged filament**

The new filament has a white deposit on the surface.  
 With use, the white deposit oxidizes and turns black: this is normal.  
 Any contact with the filament may damage it.

- ▶ Keep the filament in its protective box when it is not installed in the analyzer cell.
- ▶ Do not touch the filament with your fingers (even with gloves) or any other object.
- ▶ Do not clean the new or used filament with cloth or fingers.
- ▶ Do not dust the filament with pressurized air or by blowing on it.

#### Disassembly

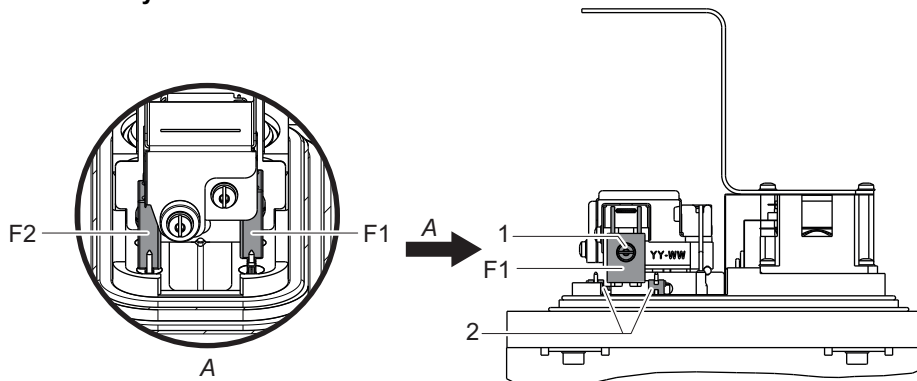

- |               |                           |
|---------------|---------------------------|
| F1 Filament 1 | 1 Fixing screw and washer |
| F2 Filament 2 | 2 Fastening clips         |

1. Remove the detector analyzer cell (see chapter “Disassembly/reassembly of the analyzer cell”).
2. Remove the fixing screw and washer of the defective filament.
3. Remove the 2 fastening clips using flat pliers (2 new clips are supplied with the spare filament).

## Reassembly

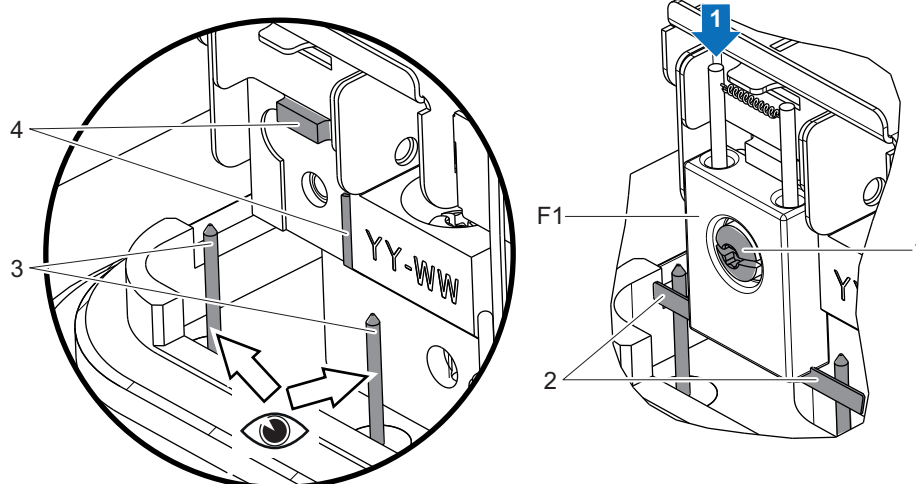

- |    |                         |   |                 |
|----|-------------------------|---|-----------------|
| F1 | Filament 1              | 3 | Connectors      |
| 1  | Fixing screw and washer | 4 | Centering stops |
| 2  | Filament strip          |   |                 |

 The connectors are perpendicular to the supporting surface and parallel to each other.

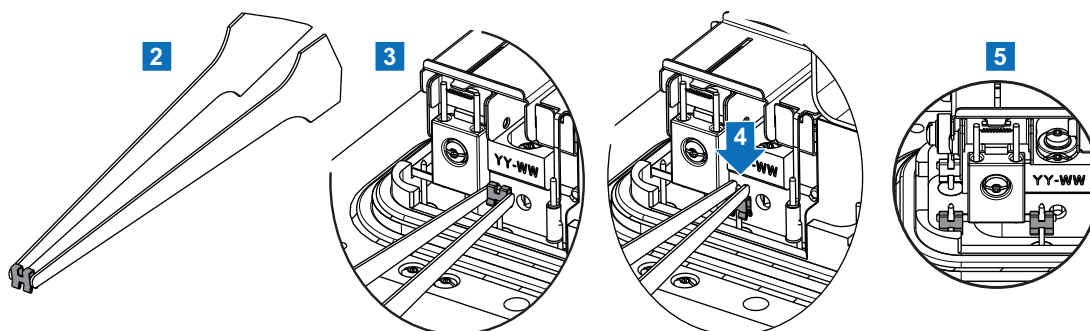

1. Place the new filament on its housing against both centering stops. Fix it with the screw and washer provided with the filament.
2. Fit the fastening clips on the connectors on each side of the filament.
3. Reassemble the analyzer cell (see chapter "Disassembly/reassembly of the analyzer cell").
4. Update the replaced filament maintenance counter from the menu (see chapter "Information" of the operating instructions).

## 5.7 Fan maintenance

## 5.7.1 Fan location

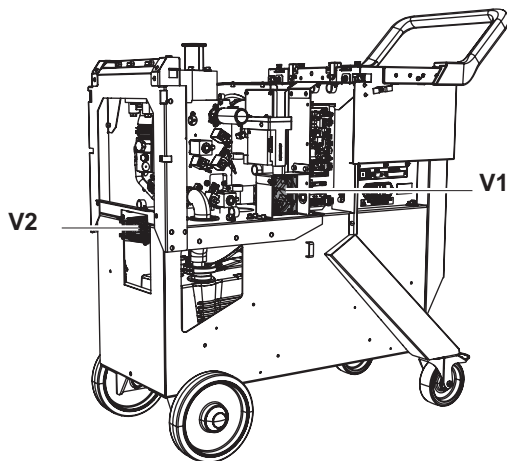

V1 Air inlet fan      V2 Air exhaust fan

## 5.7.2 Air inlet fan (V1) replacement

### Prerequisite condition(s) for the air inlet fan replacement

1. Power off the leak detector (see chapter "Powering Off").
2. Remove the work plan (see chapter "Work plan disassembly/reassembly") and the front cover (see chapter "Front cover disassembly/reassembly").

### Air inlet fan disassembly

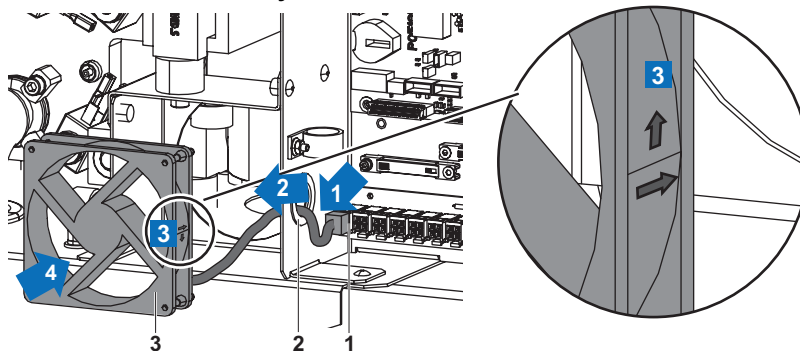

1 Harness                      3 Fan (V1)  
2 Bulkhead adapter

1. Disconnect the harness from the fan (V1).
2. Pass the cable through the bulkhead adapter
3. Remove the fan.

### Air inlet fan reassembly

1. Position the new fan, ensuring it is the correct way around.
  - Item 4 in the illustration indicates the air flow direction.
2. Pass the fan harness through the bulkhead adapter.
3. Clip on the fan.
4. Connect the harness.

## 5.7.3 Exhaust fan (V2) replacement

### Prerequisite condition(s) for the exhaust fan replacement

1. Power off the leak detector (see chapter "Powering Off").
2. Remove the work plan (see chapter "Work plan disassembly/reassembly") and the front cover (see chapter "Front cover disassembly/reassembly").

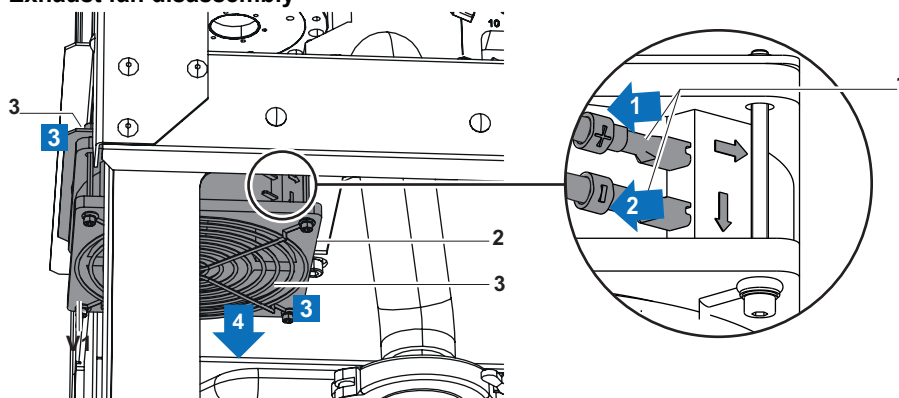
**Exhaust fan disassembly**

- 1 Harness                      3 Protection grid  
2 V2 Fan

1. Disconnect the harness from the fan (V2).
2. Remove the fan.

**Exhaust fan reassembly**

1. Position the new fan, ensuring it is the correct way around.
  - Item 4 in the illustration indicates the air flow direction.
2. Place a protective grill on each side of the fan.
3. Attach the fan.
4. Connect the fan harness, respecting the (+) and (-) polarities.

## 5.8 Filter maintenance

### 5.8.1 Vacuum block air filter replacement

**Prerequisite(s) for the vacuum block air filter disassembly**

1. Power off the leak detector (see chapter "Powering Off").
2. Remove the work plan (see chapter "Work plan disassembly/reassembly") and the front cover (see chapter "Front cover disassembly/reassembly").

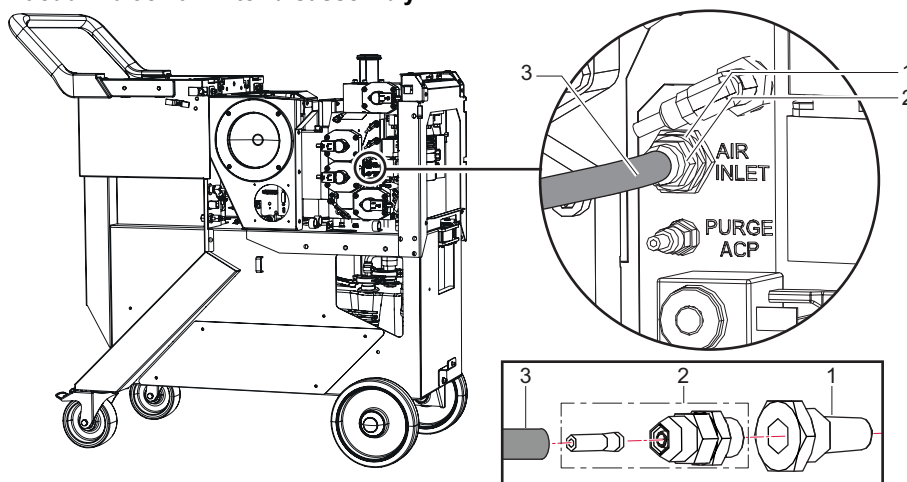
**Vacuum block air filter disassembly**

- 1 Filter                              3 Polyurethane tube  
2 Connector

1. Loosen the connector to free the tube.
2. Remove the tube.
3. Unscrew the connector in the filter.
4. Unscrew the filter in the vacuum block.

### Vacuum block air filter reassembly

1. Screw the filter in the vacuum block.
2. Screw the connector in the filter.
3. Position the tube in the connector and screw the connector.

## 5.8.2 Air inlet filter replacement

### Prerequisite(s) for the air inlet filter disassembly

- ▶ Power off the leak detector (see chapter "Powering Off").

### Air inlet filter disassembly/reassembly

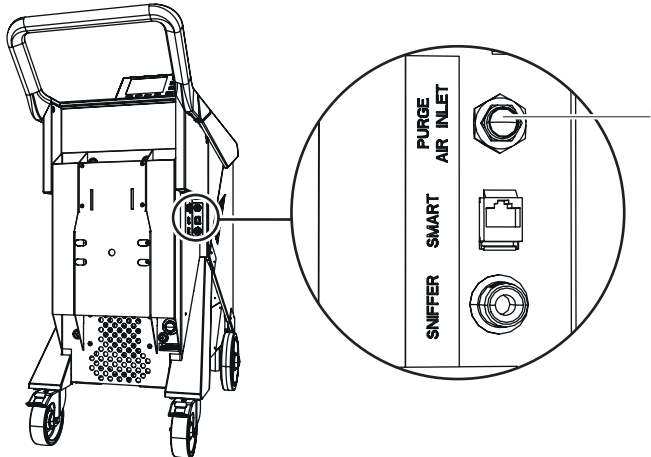

- 1 Air inlet filter

- ▶ Loosen the air inlet filter and replace it.



### Risk of pollution

The air inlet vent must never remain open to the air. Ensure the filter is on the connector at all times.

## 5.9 Pirani gauge replacement

### Tools

- ▶ Retainer screw

### Prerequisites

1. Power off the leak detector (see chapter "Powering Off").
2. Remove the work plan (see chapter "Work plan disassembly/reassembly") and the front cover (see chapter "Front cover disassembly/reassembly").

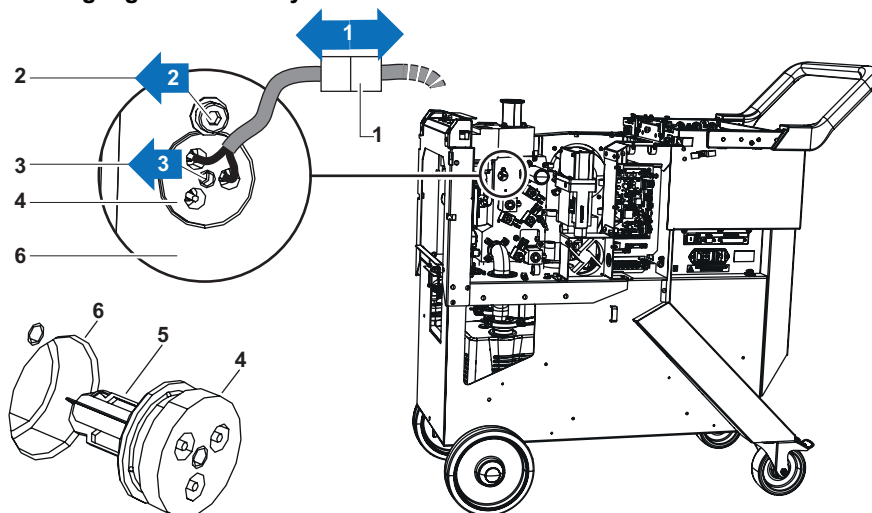
**Pirani gauge disassembly**

- |                  |                |
|------------------|----------------|
| 1 Harness        | 4 Gauge        |
| 2 Retainer screw | 5 Filaments    |
| 3 CHc screws     | 6 Vacuum block |

1. Disconnect the harness from the gauge.
2. Remove the retainer screw.
3. Screw the CHc screw into the center of the gauge (CHc screw in the maintenance kit supplied with the detector).
4. Pull on the CHc screw to free the gauge.

**Pirani gauge reassembly**

1. Position the new gauge.
  - When inserting the new gauge, do not bring the gauge filaments into contact with the vacuum block.
2. Tighten the retainer screw.
3. Connect the harness to the gauge.
4. Make adjustments to the gauge (see chapter “Calibration of the internal Pirani gauge” in the Operating Instructions).

**Tightness test after Pirani gauge maintenance**

1. Put the detector into cycle.
2. Spray a light flow of helium 4 around the gauge.
  - **leak rate measured** <  $3 \cdot 10^{-10}$  mbar·l/s ( $3 \cdot 10^{-11}$  Pa·m<sup>3</sup>/s).

## 6 Decommissioning

### 6.1 Shutting down for longer periods

If the detector must be shut down for an extended period of time, after use it is recommended that you:

1. Apply the extended storage procedure (see chapter "Storage" of the Operating Instructions).
2. Keep the detector in its original packaging or under its protective cover in a dust-free environment.
3. Recommission according to the instructions in the chapter "Operation" of the Operating Instructions. If a problem occurs, contact your Pfeiffer Vacuum service center.

### 6.2 Disposal



#### Environmental protection

The product and its components **must be disposed of in accordance with the applicable regulations relating to environmental protection and human health**, with a view to reducing natural resource wastage and preventing pollution.

Our products contain various recyclable materials: iron, steel, stainless steel, cast iron, brass, aluminum, nickel, copper, PTFE, FEP.

Familiarize yourself with the service request procedure and fill in the declaration of contamination when returning products to our service centers (see chapter "Service solutions by Pfeiffer Vacuum", page 27).

#### 6.2.1 Restriction of Hazardous Substances (RoHS)



#### The 'Restriction of Hazardous Substances' (RoHS) directive

The RoHS. directive lays down rules on the restriction of the use of hazardous substances in electrical and electronic equipment (EEE) with a view to contributing to the protection of human health and the environment, including the environmentally sound recovery and disposal of WEEE.

The manufacturer must ensure that EEE placed on the market, including cables and spare parts intended for repair, reuse, update or capacity building, contain hazardous substances subject to limitation to the extent permitted by law.

#### 6.2.2 Electrical and Electronic Equipment (EEE)

Electrical and Electronic Equipment (EEE) contain polluting material (electronic boards, batteries, screens, capacitors, mercury, etc.)

Depollution and subsequent recycling of this equipment are necessary to preserve our natural resources and particularly strategic raw materials.



This product bears the identification logo because it is subject to regulations on the management of Waste from EEE.

The manufacturer shall only be required to take back EEE marked Pfeiffer Vacuum sold by Pfeiffer Vacuum:

- EEE subject to applicable regulations for recycling end-of-life products;
- Complete, non modified EEE using original Pfeiffer Vacuum spare parts and including all of their assemblies and sub-assemblies, excluding batteries.

**Product on sale on French soil**

**In the absence of any specific contract and pursuant to current applicable legislation (and Articles R543-172 et seq. of the Environment Code in particular), all EEEs sold by Pfeiffer Vacuum on French soil are covered by the organization and financing of removal and treatment of waste from EEEs provided by Pfeiffer Vacuum.**

In order to fulfill its obligations, Pfeiffer Vacuum finances the collection and recycling of waste from EEE by subscribing to **ecosystem**. This voluntary arrangement enables owners of EEEs on French soil to benefit from easy, free solutions to ensure that EEEs subject to the regulations are recycled.

To find out more about the collection solutions, contact **ecosystem** who will inform you of the best collection solution for your needs: [www.ecosystem.eco](http://www.ecosystem.eco)

For further details, consult the General Conditions of Sale available in French on the Pfeiffer Vacuum website.

**Product on sale outside of France**









**In the absence of any specific contract and pursuant to Directive 2012/19/EC on the treatment of waste from EEE, for all EEE sold by Pfeiffer Vacuum outside of France (European Union and third countries), the owner shall be exclusively responsible for organizing and financing the collection and treatment of waste from EEE sold by Pfeiffer Vacuum.**

The owner is exclusively responsible, in particular, for its collection (gathering, sorting and storage of waste for its transportation to the treatment site), recycling, recovery and/or disposal, unless otherwise required by legal provisions applicable in the country where the owner is located, which must be reported to Pfeiffer Vacuum by the owner.

# 7 Malfunctions

## 7.1 Operation monitoring

During operation, the user is notified of an incident on the detector control panel.

Type of fault	Control panel	
Warning	Display of fault.  	Click on the pictogram  to display the fault.
Error	Display of fault.  	Click on the pictogram  to display the fault.
Critical error	Display of the message "Critical error - E244".  	Contact our service center.

## 7.2 Fault display

► Press the **i Next** pictograph. The fault is displayed.

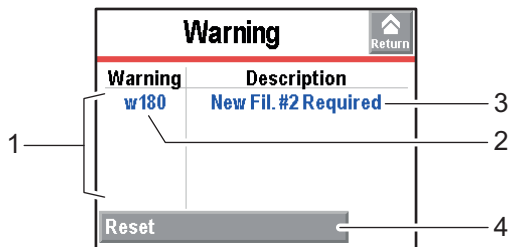

- 1 Fault list: 5 max.
- 2 RS-232 fault code
- 3 Fault description
- 4 To delete the warning and fault: it will be displayed again if the problem has not been solved.

## 8 Service solutions by Pfeiffer Vacuum

### We offer first-class service

High vacuum component service life, in combination with low downtime, are clear expectations that you place on us. We meet your needs with efficient products and outstanding service.

We are always focused on perfecting our core competence – servicing of vacuum components. Once you have purchased a product from Pfeiffer Vacuum, our service is far from over. This is often exactly where service begins. Obviously, in proven Pfeiffer Vacuum quality.

Our professional sales and service employees are available to provide you with reliable assistance, worldwide. Pfeiffer Vacuum offers an entire range of services, from original replacement parts to service contracts.

### Make use of Pfeiffer Vacuum service

Whether preventive, on-site service carried out by our field service, fast replacement with mint condition replacement products, or repair carried out in a Service Center near you – you have various options for maintaining your equipment availability. You can find more detailed information and addresses on our homepage, in the Pfeiffer Vacuum Service section.

**You can obtain advice on the optimal solution for you, from your Pfeiffer Vacuum representative.**

**For fast and smooth service process handling, we recommend the following:**



1. Download the up-to-date form templates.
  - [Explanations of service requests](#)
  - [Service requests](#)
  - [Contamination declaration](#)



- a) Remove and store all accessories (all external parts, such as valves, protective screens, etc.).
  - b) If necessary, drain operating fluid/lubricant.
  - c) If necessary, drain coolant.
2. Complete the service request and contamination declaration.



3. Send the forms by email, fax, or post to your local Service Center.

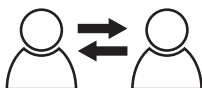

4. You will receive an acknowledgment from Pfeiffer Vacuum.

PFEIFFER VACUUM

### Submission of contaminated products

No microbiological, explosive, or radiologically contaminated products will be accepted. Where products are contaminated, or the contamination declaration is missing, Pfeiffer Vacuum will contact you before starting service work. Depending on the product and degree of pollution, **additional decontamination costs** may be incurred.

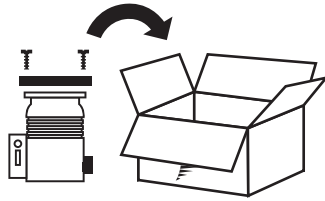

5. Prepare the product for transport in accordance with the provisions in the contamination declaration.
  - a) Neutralize the product with nitrogen or dry air.
  - b) Seal all openings with blind flanges, so that they are airtight.
  - c) Shrink-wrap the product in suitable protective foil.
  - d) Package the product in suitable, stable transport containers only.
  - e) Maintain applicable transport conditions.

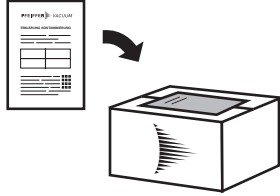

6. Attach the contamination declaration to the **outside** of the packaging.

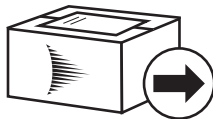

7. Now send your product to your local Service Center.

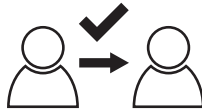

8. You will receive an acknowledgment/quotation, from Pfeiffer Vacuum.

PFEIFFER VACUUM

Our sales and delivery conditions and repair and maintenance conditions for vacuum devices and components apply to all service orders.

## 9 Spare parts

### 9.1 Tools



Designation	Qty	Part Number
<b>The maintenance set contains:</b>		<b>114718</b>
Box-shank nut spinner	1	-
Screwdriver for TORX® 6x35 screws	1	-
CHC screw, M4x80	1	-
CHC screw, M4x12	3	-
Washer, M4	3	-
CHC screw, M3x6	4	-
Washer, M3	4	-
2.5 mm male hexagonal wrench	1	-
3 mm male hexagonal wrench	1	-
4 mm male hexagonal wrench	1	-
5 mm male hexagonal wrench	1	-
Seal - 3G analyzer cell	2	-
ANXR screwdriver, 20x100	1	-

Designation	Qty	Part Number
Adaptor pack for calibrated leak, DN 16 ISO-KF	1	110715
Adaptor pack for calibrated leak, DN 25 ISO-KF	1	110716
Unequal tee, DN 25/25/16 ISO-KF	1	068269
Calibrated leak + valve 1/3 10-6, DN 25 ISO-KF	1	FV4610
Silicon vacuum grease (100 g tube)	1	064600
Needlenose pliers	1	115396

## 9.2 Leak detector spare parts

### Display

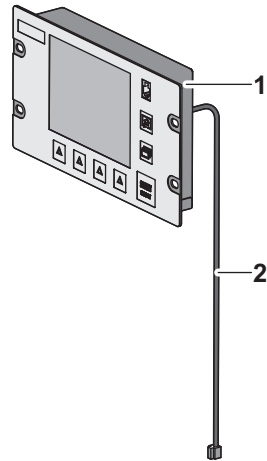

Item	Designation	P/N	Qty	Comments
1	3G control panel	122446S	1	-
2	3G control panel cable - 5 m	123909	1	-

### Ventilation

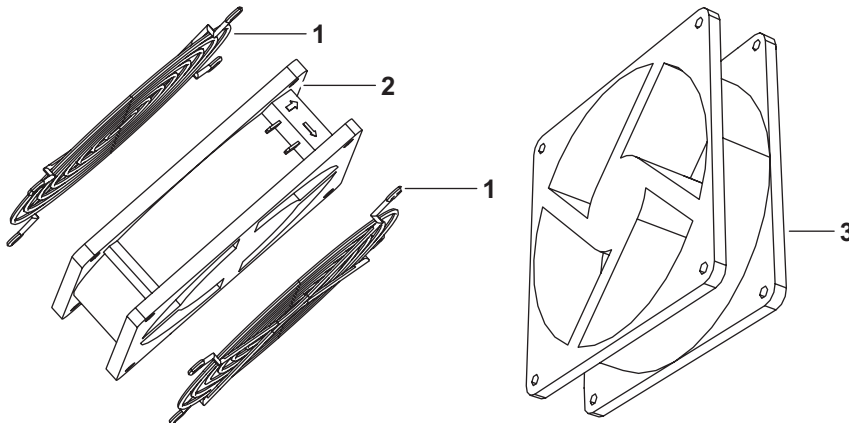

Item	Designation	P/N	Qty	Comments
1	Fan Grill 120x120 mm (101094)	056067	1	Sold individually
2	Fan	101094	1	-
3	Fan	126790	1	-

### Power and electrical supply



Item	Designation	P/N	Qty	Comments
1	Mains cable, 6 m 15 A - USA	126141	1	-
2	Mains cable, 6 m 16 A - Europe	126142	1	-

### Measurement

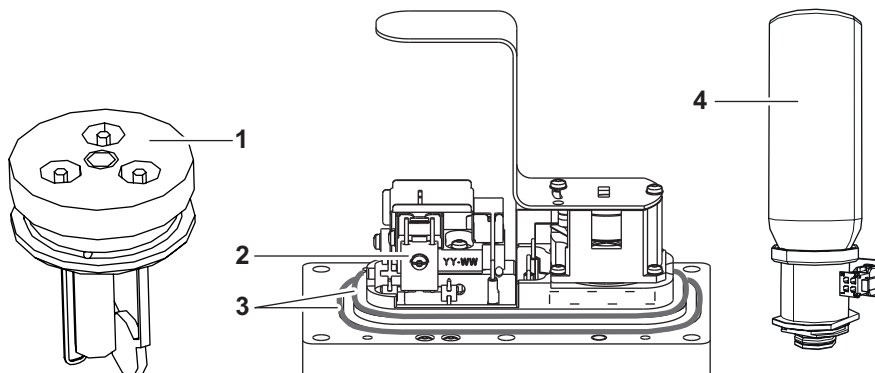

Item	Designation	P/N	Qty	Comments
1	PI1 gauge, aluminum	795706	1	-
2	Filament - 3G analyzer cell	114864S	1	-
3	NBR seal - 3G analyzer cell	114346	1	Sold individually
4	Internal calibrated leak	121528S	1	-

### Vacuum block

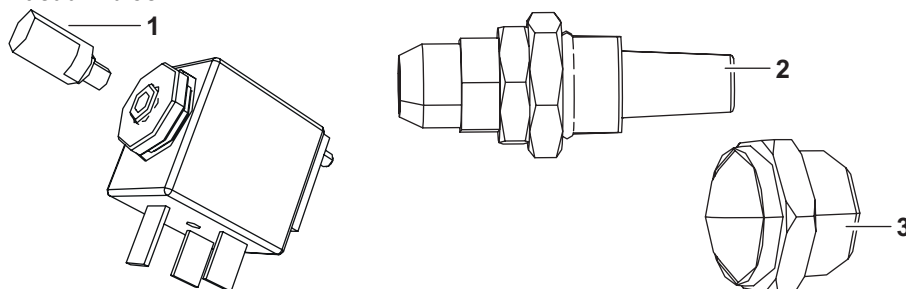

Item	Designation	P/N	Qty	Comments
1	Silencer, M5 sintered bronze	108449	1	-
2	Vacuum block sintered filter	122237	1	-
3	Silencer, 1/4" stainless steel wire braid	101552	1	-

### Exhaust

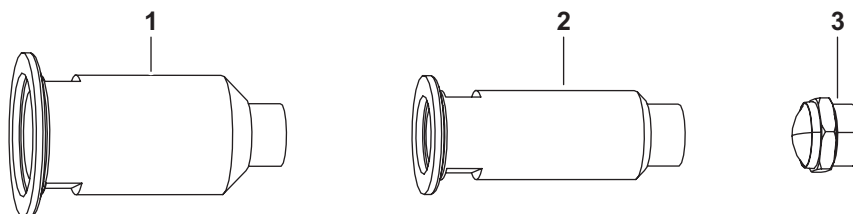

Item	Designation	P/N	Qty	Comments
1	Exhaust pipe, DN 25 ISO-KF	126602	1	-
2	Exhaust pipe, DN 40 ISO-KF	126603	1	-
3	Silencer, 1/2" stainless steel wire braid	109369	1	-

**Pipes - Connections - Seals**

Item	Designation	P/N	Qty	Comments
-	Stainless steel flexible pipe, DN 25/40 ISO-KF - L 250 mm	101539	1	-
-	Silencer, 1/2" stainless steel wire braid	109369	1	-
-	Silencer, 1/4" stainless steel wire braid	101552	1	-
-	Quick connect clamp, DN 10/16 ISO-KF	110BSR016	1	-
-	Quick connect clamp, DN 20/25 ISO-KF	120BSR025	1	-
-	Quick connect clamp, DN 32/40 ISO-KF	120BSR040	1	-
-	Stainless steel blanking plate, DN 40 ISO-KF	120FBL040	1	-
-	HNBR O-ring, DN 25 ISO-KF	106022	1	-
-	HNBR O-ring, DN 40 ISO-KF	106023	1	-
-	HNBR O-ring, DN 16 ISO-KF	106021	1	-
-	Centering ring, DN 25 ISO-KF	120ZRG025	1	-
-	Centering ring, DN 40 ISO-KF	120ZRG040	1	-
-	HNBR O-ring, DN 63 ISO-K	106816	1	-
-	Centering ring, DN 16 ISO-KF	120ZRG016	1	-
-	NBR seal - 3G analyzer cell	114346	1	Sold by the meter
-	Polyurethane tube, D6 thickness 1 mm	118207	1	Sold by the meter
-	Centering ring, DN 63 ISO-K	068174	1	Sold by the meter

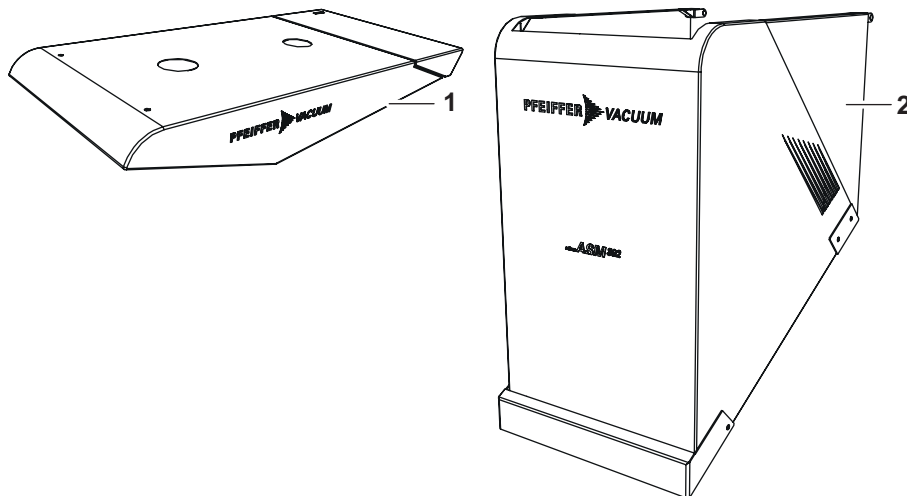
**Cover**

Item	Designation	P/N	Qty	Comments
1	Work plan - ASM 390/392	126789	1	-
2	Equipped front cover - ASM 390/392	126249S	1	-

**9.3 Accessories**

Item	Designation	Part Number	Qty	Comments
-	O-ring Ø 5 mm - D 114 mm	082152	1	-
-	Bronze dust filter 20 µm D 114 mm	105847	1	-
-	Bronze dust filter 5 µm D 114 mm	105848	1	-
-	Bronze dust filter 20 µm, DN 25/25 ISO-KF	105841	1	-
-	Bronze dust filter 20 µm, DN 40/40 ISO-KF	105842	1	-
-	Bronze dust filter 20 µm, DN 40/25 ISO-KF	105843	1	-

Item	Designation	Part Number	Qty	Comments
-	Bronze dust filter 5 µm, DN 25/25 ISO-KF	105844	1	-
-	Bronze dust filter 5 µm, DN 40/40 ISO-KF	105845	1	-
-	Bronze dust filter 5 µm, DN 40/25 ISO-KF	105846	1	-
-	Stainless steel dust filter D 114 mm	-	1	5 or 15 µm - Consult us
-	Stainless steel dust filter, DN 25/25 ISO-KF	-	1	5 or 15 µm - Consult us
-	Stainless steel dust filter, DN 40/40 ISO-KF	-	1	5 or 15 µm - Consult us
-	Stainless steel dust filter, DN 40/25 ISO-KF	-	1	5 or 15 µm - Consult us

## VACUUM SOLUTIONS FROM A SINGLE SOURCE

Pfeiffer Vacuum stands for innovative and custom vacuum solutions worldwide, technological perfection, competent advice and reliable service.

## COMPLETE RANGE OF PRODUCTS

From a single component to complex systems:

We are the only supplier of vacuum technology that provides a complete product portfolio.

## COMPETENCE IN THEORY AND PRACTICE

Benefit from our know-how and our portfolio of training opportunities!

We support you with your plant layout and provide first-class on-site service worldwide.

Ed. 03 - Date 2021/07 - P/N:126348MEN



Are you looking for a  
perfect vacuum solution?  
Please contact us

Pfeiffer Vacuum GmbH  
Headquarters • Germany  
T +49 6441 802-0  
info@pfeiffer-vacuum.de

[www.pfeiffer-vacuum.com](http://www.pfeiffer-vacuum.com)