

TURBOVAC i(X)

TURBOVAC 90 i(X), 250 i(X),
(T) 350 i(X), (T) 450 i(X)

Turbomolecular Pumps with Integrated
Frequency Converter (and Control Unit)

Operating Instructions 300554863_002_C0

Part Nos.

810030V1000 to 810089V9999

820050V1000 to 820089V9999

830050V1000 to 830089V9999



Contents

	Page
0 Important Safety Information	5
0.1 Mechanical hazards	5
0.2 Electrical hazards	6
0.3 Thermal hazards	7
0.4 Hazards caused by materials and substances	7
0.5 Danger of ignition	8
0.6 Dangers in connection with safety-related measures and precautions	8
0.7 Risk of damaging the pump	8
1 Description	9
1.1 Design	11
1.2 Standard equipment	11
1.3 Technical data	12
1.3.1 Technical data for the integrated drive electronics	22
1.4 Ordering data	35
1.5 Accessories	36
2 Transport and storing	39
3 Installation	40
3.1 Conforming utilization	40
3.1.1 Non-conforming utilization	40
3.2 Operating environment	41
3.3 Fitting accessories	42
3.4 Attach the pump to the vacuum chamber	45
3.5 Forevacuum connection	50
3.6 Connect the cooling	52
3.6.1 Air cooling	52
3.6.2 Water cooling	53
3.6.3 Water Quality	53
3.7 Connect a power failure venting valve or a venting valve	56
3.8 Connect purge gas	57
3.9 Connect a flange heater	58
3.10 Connect a vacuum gauge head (only for TURBOVAC iX)	59
3.11 Electrical connection	60

4	Operation	65
4.1	Media compatibility / purge gas	65
4.2	Interfaces	65
4.3	Switching on	67
4.4	Shutting down	68
4.5	Venting	69
4.6	Bakeout	70
4.7	Removing the pump from the system	71
5	Maintenance	72
5.1	Cleaning	72
5.2	Leybold Service	73
6	Troubleshooting	74
7	Waste Disposal	76
	Certificates	76
	EC Incorporation Declaration	77
	EC Declaration of Conformity	78

The TURBOVAC allows through both standard and optional interfaces controlling of the pump and setting up of some pump functions according to specific requirements. The Operating Instructions **300450826 Serial Interfaces for TURBOVAC i/iX** offers detailed information on the RS 232, RS 485, Profibus and USB interfaces of the TURBOVAC.

Original operating instructions.

Safety Information

NOTICE



Obligation to Provide Information

Before installing and commissioning the pump, carefully read these Operating Instructions and follow the information so as to ensure optimum and safe working right from the start.

The Leybold **TURBOVAC** has been designed for safe and efficient operation when used properly and in accordance with these Operating Instructions. It is the responsibility of the user to carefully read and strictly observe all safety precautions described in this section and throughout the Operating Instructions. The pump must only be operated in the proper condition and under the conditions described in the Operating Instructions. It must be operated and maintained by trained personnel only. Consult local, state, and national agencies regarding specific requirements and regulations. Address any further safety, operation and/or maintenance questions to our nearest office.

DANGER



DANGER indicates an imminently hazardous situation which, if not avoided, will result in death or serious injury.

WARNING



WARNING indicates a potentially hazardous situation which, if not avoided, could result in death or serious injury.

CAUTION



CAUTION indicates a potentially hazardous situation which, if not avoided, could result in minor or moderate injury.

NOTICE



NOTICE is used to notify users of installation, operation, programming or maintenance information that is important, but not hazard related.

We reserve the right to alter the design or any data given in these Operating Instructions. The illustrations are not binding.

Retain the Operating Instructions for further use.

0 Important Safety Information

0.1 Mechanical hazards

- 1 Avoid exposing any part of the human body to the vacuum.
- 2 The pressure in the pump must not exceed 1.4 bar (absolute).
- 3 The pump is intended for generating a vacuum only. If there is a risk of an overpressure within the system and the pump, then the pump must be protected against this, by way of an overpressure safety valve, for example.
- 4 Vent the pump only up to atmospheric pressure.
- 5 When using the pump with a purge gas valve, protect the purge gas supply such that in the event of a malfunction no overpressure can occur within the system.
- 6 The pump must be firmly mounted to the vacuum chamber. If the mounting is not sturdy enough, pump blockage could cause the pump to break loose; internal pump components could be thrown in all directions. Never operate the pump (in bench testing, for example) without proper flanging to the vacuum chamber. Observe the information in Section 3.4.
- 7 Due to high-speed and temperature, the service life of the rotor is limited. If the rotor is changed too late, it may be destroyed. Thus in the flange mounts high forces and torque conditions can occur. The mounting screws for the pump may be torn off. We recommend an exchange of the rotor unit after 80,000 operating hours at the latest. When using clamped flange connections at the housing or with components above the housing, sudden twisting of the entire pump can be experienced.
- 8 Turbopumps as described in the following operation manual contain a high portion of kinetic energy due to their high rotational speed in combination with the specific rotor mass. In case of a malfunction of the system, for example rotor/stator contact or even a rotor crash, the rotational energy is released.
- 9 To avoid the destruction of the equipment and to prevent injuries of the operating staff the leading European manufacturers of vacuum pumps strictly recommend to follow the installation instructions as given in this manual.

WARNING



Safety Information

DANGER



0.2 Electrical hazards

- 1 The electrical connection must only be provided by a trained person. Please observe the national regulations in the country of use like EN 50110-1 for Europe, for example.
- 2 The pump must only be connected to power supplies which meet the requirements for functional extra-low voltages with positive isolation in accordance with IEC 60364-4-41 (or local regulations) (PELV). All interfaces must only be operated with PELV-fed components and devices.
- 3 Lethal voltages are present at the mains connections. Before starting with any maintenance and service work, de-energise (lockout/tagout) the product first.
- 4 Unplug any connectors only when the mains voltage is switched off and the pump does no longer turn.
- 5 Unauthorized device conversion and modifications are prohibited for safety reasons.
- 6 The outputs at the frequency converter are not free of voltage.
- 7 Lay connecting lines so that they cannot be damaged. Protect the lines against humidity and contact with water. Avoid any heat stress on the line due to unfavourable laying conditions.
- 8 Suitably support the connecting lines so that the pumps are not exposed to any major mechanical stress.
- 9 Do not expose the pump and the connections to dripping water. Note the information on the IP type of protection.
- 10 When storing the pump in a humid atmosphere, these can suffer corrosion. Corrosion gives rise to conductive deposits which in turn can cause short-circuits and reduce the insulation levels of electrical components
- 11 Transport the pump only in its original packaging so as to avoid any mechanical damage which in turn may reduce air gaps and creepage distances.
- 12 When applying external voltages above 42 V to the connection terminals, observe the applicable VDE safety regulations!
- 13 Make the electrical connections only after pump and accessories (e.g. air cooler) have been installed mechanically.
- 14 The slot for the Anybus interface must be blanked off during operation of the pump: either through a blank panel or by inserting an optional Anybus module.

0.3 Thermal hazards

- 1 Handle the equipment only while vented and cooled down.
- 2 During operation of the pump certain areas can get hot (65 °C max.). Protect hot parts against being touched.

CAUTION



0.4 Hazards caused by materials and substances

- 1 The pump is not suited for pumping of reactive or corrosive media. If the rotor is attacked by process gases, it can suffer destruction. Thus in the flange mounts high forces and torque conditions can occur. The mounting screws for the pump may be torn off. When using clamped flange connections at the housing or with components above the housing, sudden twisting of the entire pump can be experienced.
- 2 When pumping dusty media, use a dust filter. The pollution degree II applies to the pump's inside, too.
- 3 If low concentration corrosive or reactive gases are being pumped, then operate the pump with purge gas.
- 4 Please consult us as to which types of pump are required for specific processes and applications.
- 5 The forevacuum line must be tight. Hazardous gases can escape at leaks or the gases being pumped can react with air or humidity. A leak search will always be required after having installed the pump and after service work on the vacuum system. Upon delivery the pump has an integral leak rate of $< 1 \cdot 10^{-8}$ mbar·l/s. When pumping toxic gases we recommend a leak search on a regular basis.
- 6 If the pump has previously handled hazardous gases, implement the proper precautionary measures before opening the intake or exhaust connection. Before opening the pump, purge it for a longer period of time with an inert gas. If necessary, use gloves, a respirator and/or protective clothing and work under an exhaust hood. Firmly seal off the pump. When shipping the contaminated pump for servicing, please also state the type of hazard. For this you must use a form which we have prepared for you.
- 7 Contaminated parts can be detrimental to health and environment. Before beginning with any work, first find out whether any parts are contaminated. Adhere to the relevant regulations and take the necessary precautions when handling contaminated parts.
- 8 The cooling water from the return is not of drinking water quality and should not be used for this purpose. After having operated the pump, the cooling water lines may suffer from microbiological contamination. Take appropriate safety precautions.

DANGER



Safety Information

CAUTION**0.5 Danger of ignition**

- 1 During operation the pressure inside the turbomolecular pump is so low that there is no danger of ignition (at pressures below about 100 mbar). A hazardous condition will be created if flammable mixtures enter the hot pump at pressures above 100 mbar. During operation the pump can reach temperatures as high as 140 °C internally, and at parts of the outside surfaces 65 °C. Sparks could occur in case of damage to the pump and these could ignite explosive mixtures. Also note the safety information provided by the gas supplier.

CAUTION**0.6 Dangers in connection with safety-related measures and precautions**

- 1 The frequency converter is not equipped with its own emergency shut down switch. Such a facility needs to be provided from the side of the system.

NOTICE**0.7 Risk of damaging the pump**

- 1 Never touch the rotor. Touching the rotor may cause injury and damage the rotor bearing.
 - 2 Foreign objects which enter the pump through the intake would cause serious damage to the rotor. That's why we recommend installing an inlet screen. Damages caused during operation without the inlet screen are excluded from warranty.
 - 3 The contact surfaces of pump housing, vacuum system and centering ring must be free of grease and dry so as to ensure sufficient stability in case the rotor seizes.
 - 4 Connect a purge gas or venting valve to the correct flange. Confusing the venting and purge gas flange can cause shock venting of the pump.
 - 5 The interface connectors have UNC 4-40 threads. Do not use connectors with M3 threads.
 - 6 Disconnect and connect the cable connections between pump and power supply only while the pump is turning no longer (green status LED off) **and** with the mains power switched off (yellow power LED off). Otherwise there is the risk of damaging the frequency converter.
 - 7 Exposure of the pump to accelerating forces must be avoided or reduced to such an extent that the rotor unit will not be excited by vibrations. In the case of critical applications you must consult our Applications Dept. first.
-

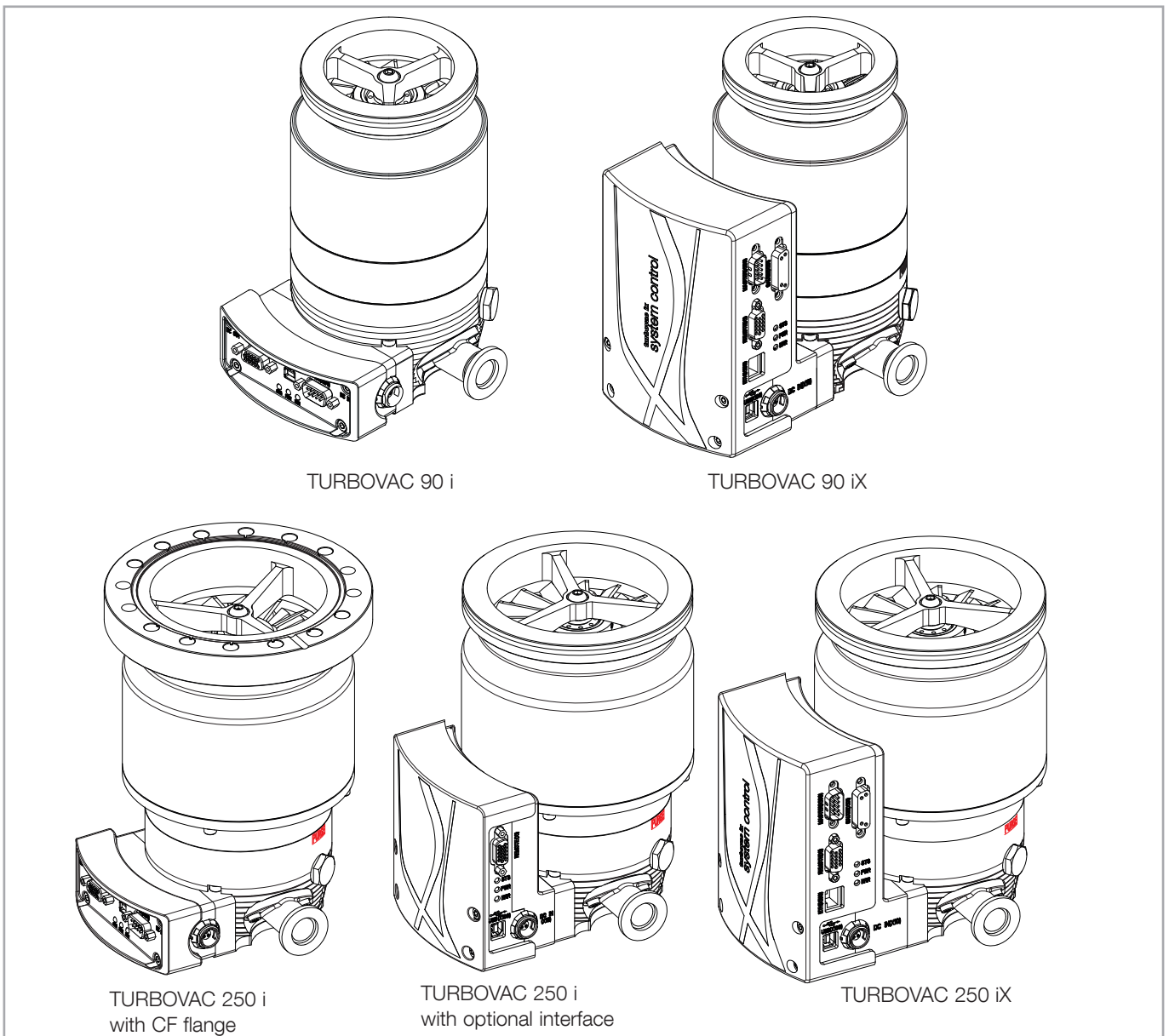

Fig. 1.1 TURBOVAC 90/250 i(X) models

1 Description

The TURBOVAC 90 i(X), 250 i(X), (T) 350 i(X) and (T) 450 i(X) are turbomolecular pumps designed to evacuate vacuum chambers down to pressure levels in the high vacuum and ultra-high vacuum range.

They are suitable for pumping air and clean gases. A forevacuum pump and a power supply are required for their operation.

Description

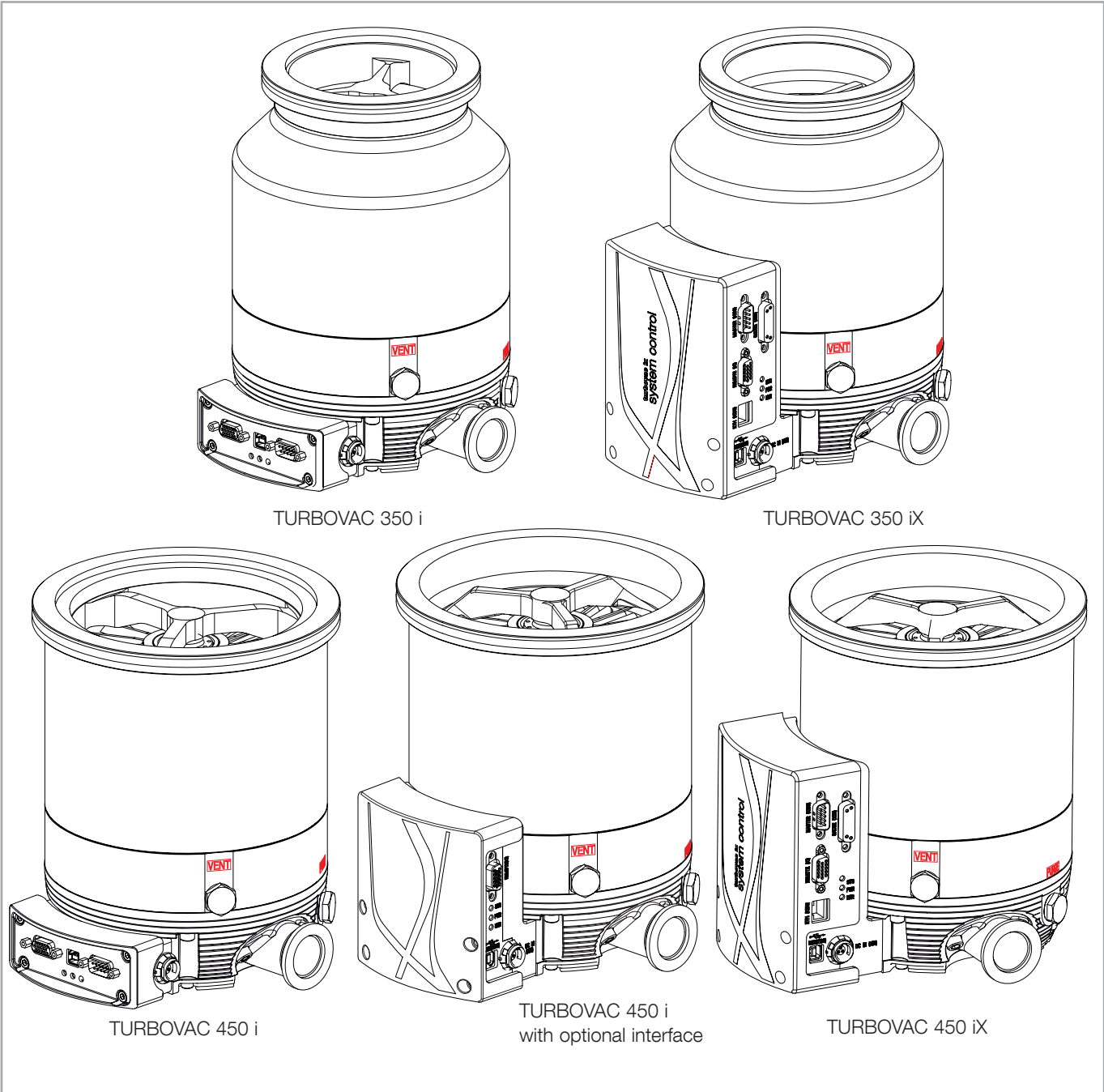

Fig. 1.2 TURBOVAC 350/450 i(X) models

1.1 Design

The pump models TURBOVAC **T** ... i(X) are of the standard TMP rotor type; the TURBOVAC ... i(X) models are wide-range TMPs equipped with an additional Holweck stage.

With the built-in frequency converter as the electronic drive the TURBOVAC i(X) forms one single unit. The electronic drive governs the pump's speed and serves as a monitor for all functions of the pump. Moreover, the TURBOVAC **iX** is equipped with an integrated vacuum system controller for connection and operation of various accessory components.

At the high vacuum side the bearing is of a non-wearing permanent magnetic bearing type, at the forevacuum side a lifetime lubricated oil-free ceramic ball bearing is used.

Water cooling or an air cooling fan is available as optional equipment.

The intake flange should be fitted with a wire mesh inlet screen to protect the pump against mechanical damage caused by foreign objects.

The pumps are equipped with a venting and a purge gas facility. The connections are blanked off by default with G1/8" closure screws.

Venting and purge gas valves, or a venting screw, or a pressure regulator can be connected directly to the pump.

1.2 Standard equipment

Turbomolecular pump with integrated electronic drive unit (and integrated vacuum system control unit for TURBOVAC iX)

High and fore-vacuum flanges are protective-capped.

Flange mounting elements, the DC In plug and the inlet screen are not enclosed, but are available as accessories, see Section 1.5.

Only TURBOVAC iX

An USB stick with the LEYASSIST software is included.

Description

1.3 Technical data

TURBOVAC		90 i(X)	250 i(X)
High-vacuum connection	DN	63 ISO-K 63 CF	100 ISO-K 100 CF
Forevacuum connection	DN	16 KF	16 KF
Pumping speed*	$l \cdot s^{-1}$		
N ₂		90	225
Ar		83	210
He		90	250
H ₂		78	210
Gas throughput*	$mbar \cdot l \cdot s^{-1}$		
N ₂		10	6
Ar		3	3
He		11	6
H ₂		11	> 10
Compression ratio*			
N ₂		$1 \cdot 10^{11}$	$1 \cdot 10^{11}$
Ar		$1 \cdot 10^{11}$	$1 \cdot 10^{11}$
He		–	–
H ₂		$5 \cdot 10^7$	$2 \cdot 10^7$
Ultimate pressure with 2-stage oil-sealed rotary vane pump ISO-K / CF	mbar	$< 8 \cdot 10^{-8} / < 5 \cdot 10^{-10}$	
Max. permissible forevacuum pressure for N ₂	mbar	14	
Operating speed	min^{-1}	72 000	
Speed adaptation		62 to 100 %	
Run-up time, approx.	min	2	
Max. power consumption	W	240	
Power consumption at ultimate pressure, approx.	W		
24 V		7	7
48 V		9.5	10
Type of protection	IP	40	

* Please contact us when using Argon or other “heavy” gases as process gas.

Description

TURBOVAC		90 i(X)	250 i(X)
Ambient temperature during operation storage	°C		+5 to +45 -15 to +70
Cooling standard			Convection
Cooling optional			Air or water
Cooling water connection			plug connection for 6x1 hose / alternatively G 1/8-in. screw-in thread
Cooling water consumption	l/h		30 to 60
Permissible cooling water pressure (bar(g): bar (gauge) is overpressure, i.e. atmospheric pressure = 0 bar(g))	bar(g)		3 - 6
Permissible cooling water temperature	°C		15 to 35
Weight ISO-K / CF TURBOVAC i TURBOVAC iX	kg	3.1 / 4.8 3.6 / 5.3	4,0 / 6,6 4,5 / 7,1
Recommended forevacuum pumps	TRIVAC SCROLLVAC DIVAC	D 2,5 E / D 4 B SC 5 D 1,4 HV 3	D 2,5 E / D 4 B SC 5 D / SC 15 D 3,8 HV 3
Noise level with convection cooling with radial air cooler with axial air cooler	dB(A)		< 41 < 44 < 49
Max. bake-out temperature of the CF version, water cooled	°C		100
Max. rel. air humidity			approx. 85% (non-condensing)
Purge gas flow	mbar · l · s ⁻¹ sccm		0.4 24
Purge gas connection			G 1/8"
Venting connection			G 1/8"

Description

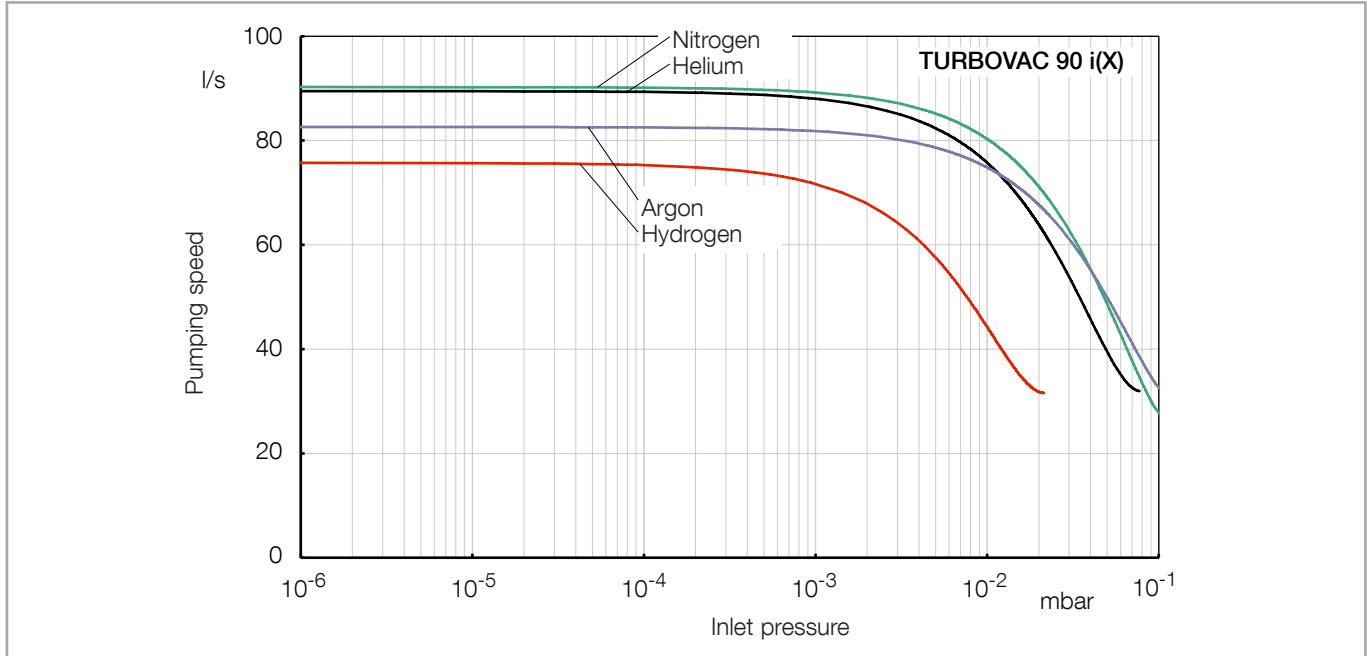

Fig. 1.3 Pumping speed curves for the TURBOVAC 90 i(X)

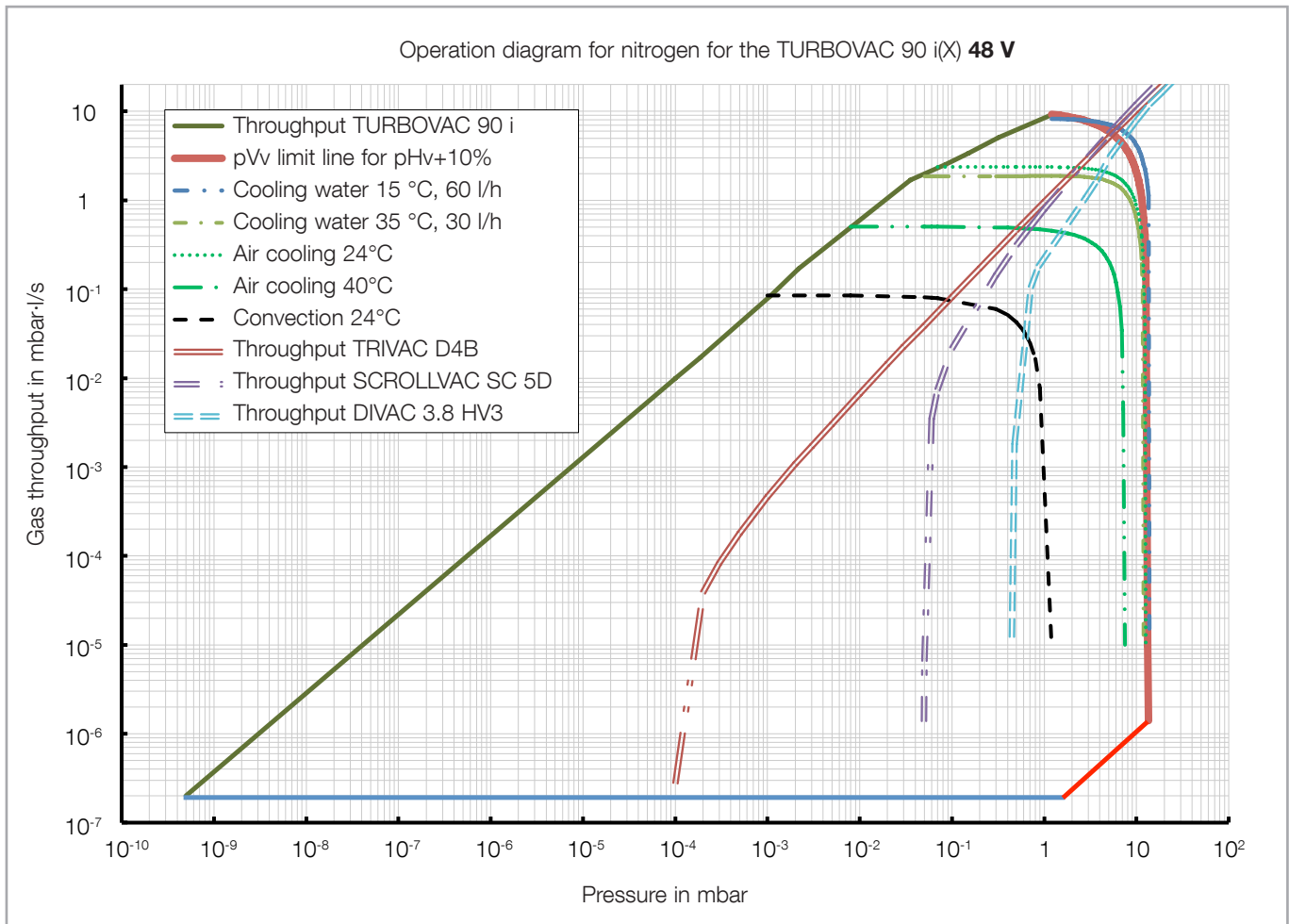

Fig. 1.4a Operation diagram for nitrogen for the TURBOVAC 90 i(X) 48 V

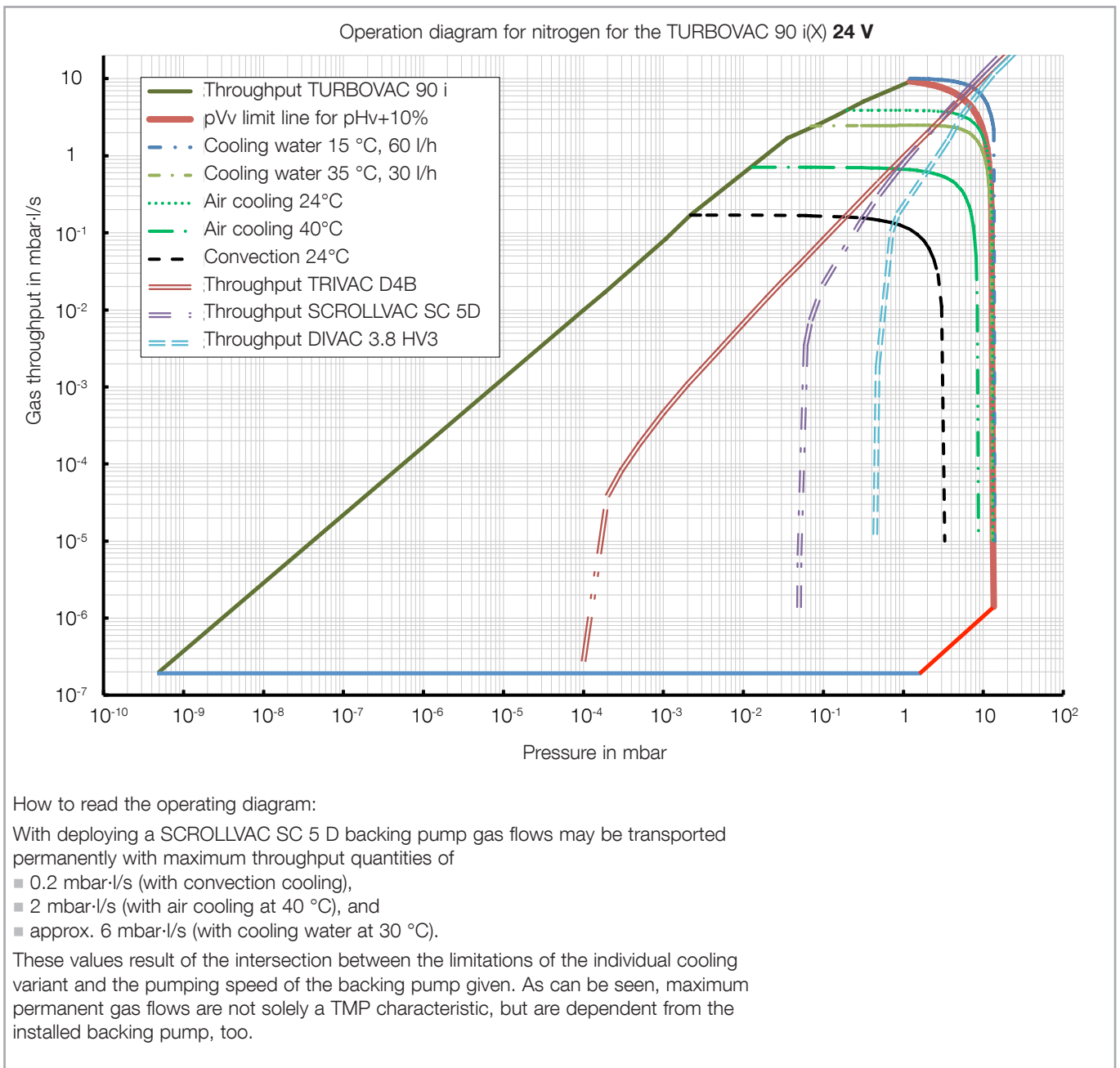

Fig. 1.4b Operation diagram for nitrogen for the TURBOVAC 90 i(X) 24 V

Description

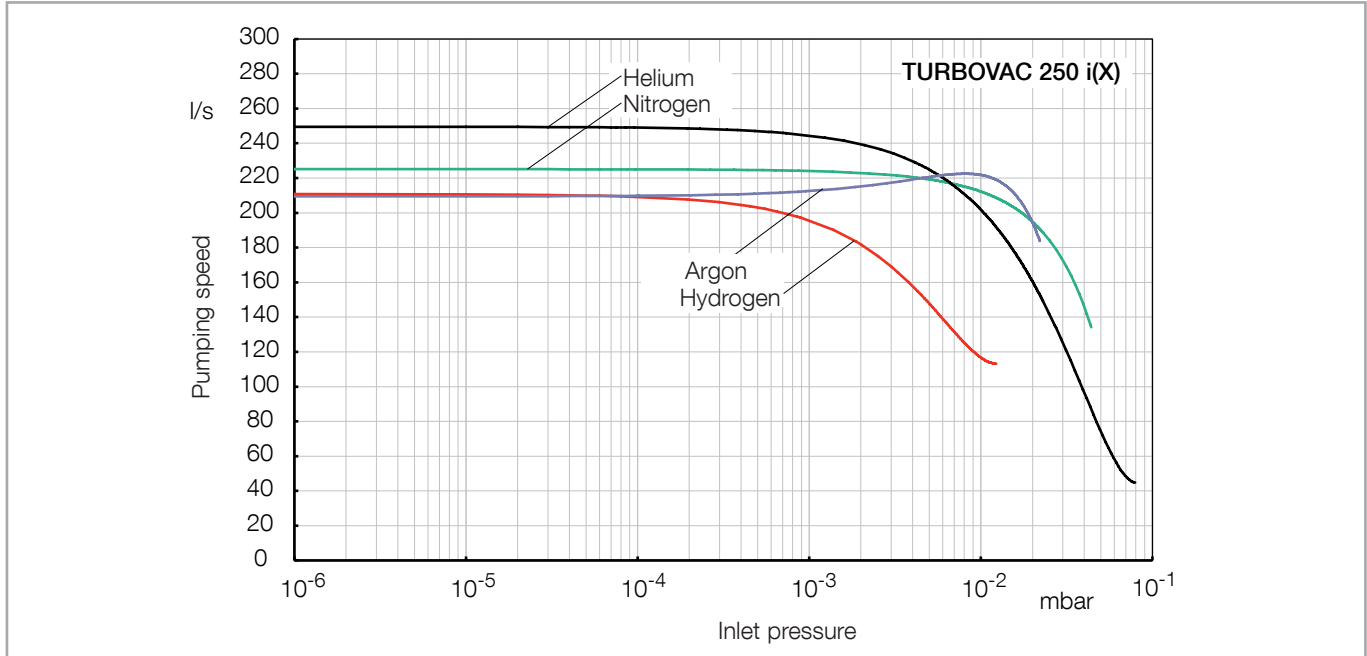

Fig. 1.5 Pumping speed curves for the TURBOVAC 250 i(X)

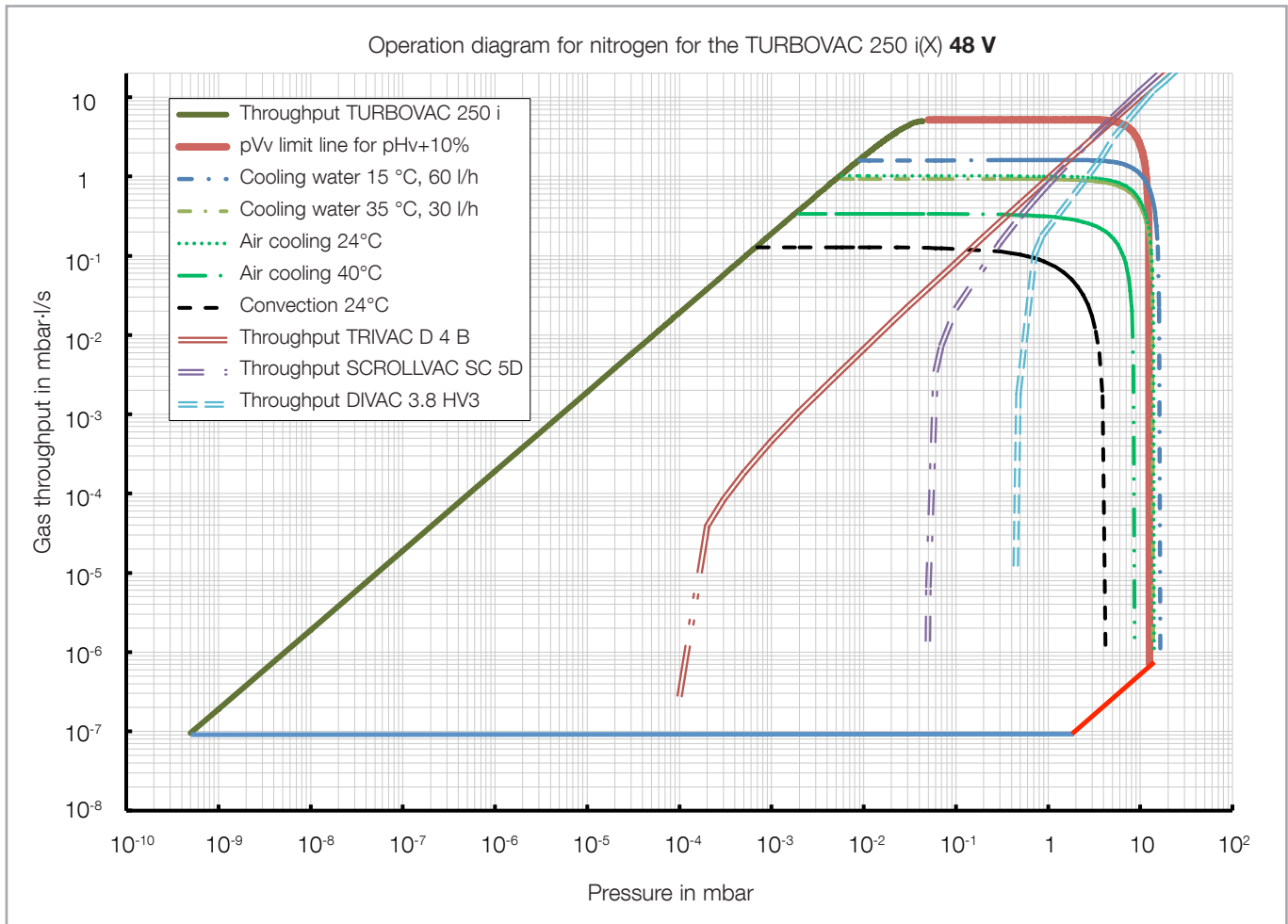

Fig. 1.6a Operation diagram for nitrogen for the TURBOVAC 250 i(X) 48 V

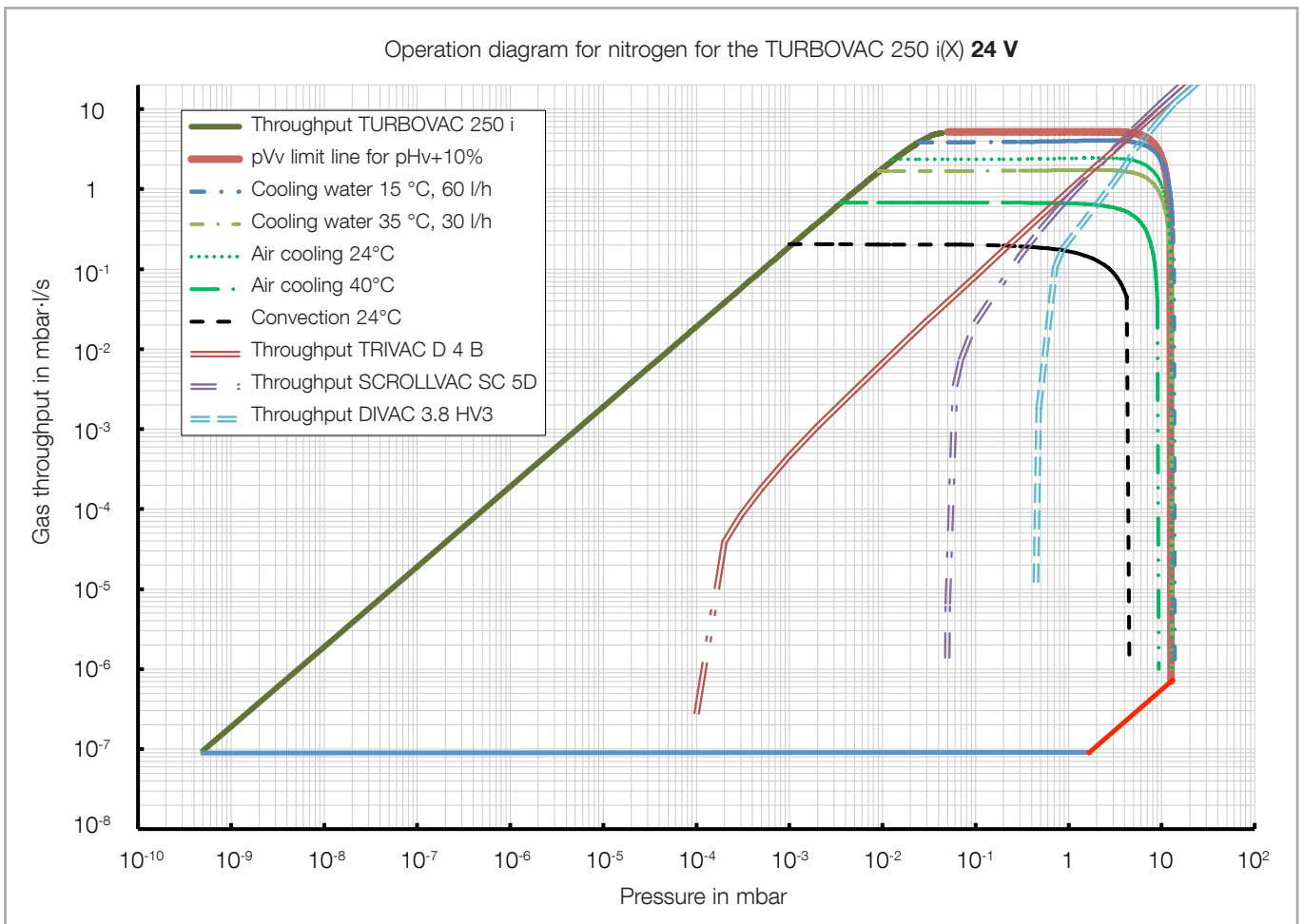

Fig. 1.6b Operation diagram for nitrogen for the TURBOVAC 250 i(X) 24 V

How to read the operating diagram:

With deploying a SCROLLVAC SC 5 D backing pump gas flows may be transported permanently with maximum throughput quantities of

- 0.2 mbar·l/s (with convection cooling),
- 0.7 mbar·l/s (with air cooling at 40 °C), and
- approx. 2 mbar·l/s (with cooling water at 35 °C).

These values result of the intersection between the limitations of the individual cooling variant and the pumping speed of the backing pump given. As can be seen, maximum permanent gas flows are not solely a TMP characteristic, but are dependent from the installed backing pump, too.

Description

TURBOVAC		350 i(X)	T 350 i(X)	450 i(X)	T 450 i(X)
High-vacuum connection	DN	100 ISO-K 100 CF	100 ISO-K 100 CF	160 ISO-K 160 CF	160 ISO-K 160 CF
Forevacuum connection	DN	25 KF	25 KF	25 KF	25 KF
Pumping speed for	$l \cdot s^{-1}$				
N ₂		290	290	430	430
Ar		260	260	400	400
He		360	360	440	440
H ₂		350	320	420	400
Gas throughput	$mbar \cdot l \cdot s^{-1}$				
N ₂		4.5	11.5	4.5	11.5
Ar		2.0	6.0	2.0	6.0
He		8.0	20.0	8.0	20.0
H ₂		8.0	20.0	8.0	20.0
Compression ratio					
N ₂		$1 \cdot 10^{11}$	$1 \cdot 10^{10}$	$1 \cdot 10^{11}$	$1 \cdot 10^{10}$
Ar		$1 \cdot 10^{11}$	$1 \cdot 10^{11}$	$1 \cdot 10^{11}$	$1 \cdot 10^{11}$
He		$1 \cdot 10^8$	$1 \cdot 10^6$	$1 \cdot 10^8$	$1 \cdot 10^6$
H ₂		$1 \cdot 10^6$	$1 \cdot 10^4$	$1 \cdot 10^6$	$1 \cdot 10^4$
Ultimate pressure with 2-stage oil-sealed rotary vane pump ISO-K / CF	mbar	$< 8 \cdot 10^{-8} / < 5 \cdot 10^{-10}$			
Max. permissible forevacuum pressure for N ₂	mbar	10	0.5	10	0.5
Operating speed	min^{-1}	60 000			
Speed adaptation		50 to 100 %			
Run-up time, approx.	min	5.5	3.5	5.5	3.5
Max. power consumption	W	240			
Power consumption at ultimate pressure	W	20			
Type of protection	IP	40			

Description

TURBOVAC		350 i(X)	T 350 i(X)	450 i(X)	T 450 i(X)
Ambient temperature during operation storage	°C			+5 to +45 -15 to +70	
Cooling standard				Convection	
Cooling optional				Air or water	
Cooling water connection				plug connection for 6x1 hose / alternatively G 1/8-in. screw-in thread	
Cooling water consumption	l/h			50 to 100	
Permissible cooling water pressure (bar(g): bar (gauge) is overpressure, i.e. atmospheric pressure = 0 bar(g))	bar(g)			3 - 6	
Permissible cooling water temperature	°C			15 to 35	
Weight ISO-K / CF TURBOVAC i TURBOVAC iX	kg	7.5 / 11.5 8.0 / 12.0	7.0 / 11.0 7.5 / 11.5	7.7 / 12.5 8.2 / 13.0	7.2 / 12.0 7.7 / 12.5
Recommended forevacuum pumps	TRIVAC SCROLLVAC DIVAC	D 4 B SC 5/15 D 3.8 HV3	D 16 B SC 15D / 30D -	D 4 B SC 5/15 D 3.8 HV3	D 16 B SC 15D / 30D -
Noise level with convection cooling with radial air cooler with axial air cooler	dB(A)			< 44 < 47 < 49	
Max. bake-out temperature of the CF version, water cooled	°C			100	
Max. rel. air humidity				approx. 85% (non-condensing)	
Purge gas flow	mbar · l · s ⁻¹ sccm			0.4 24	
Purge gas connection				G 1/8"	
Venting connection				G 1/8"	

Description

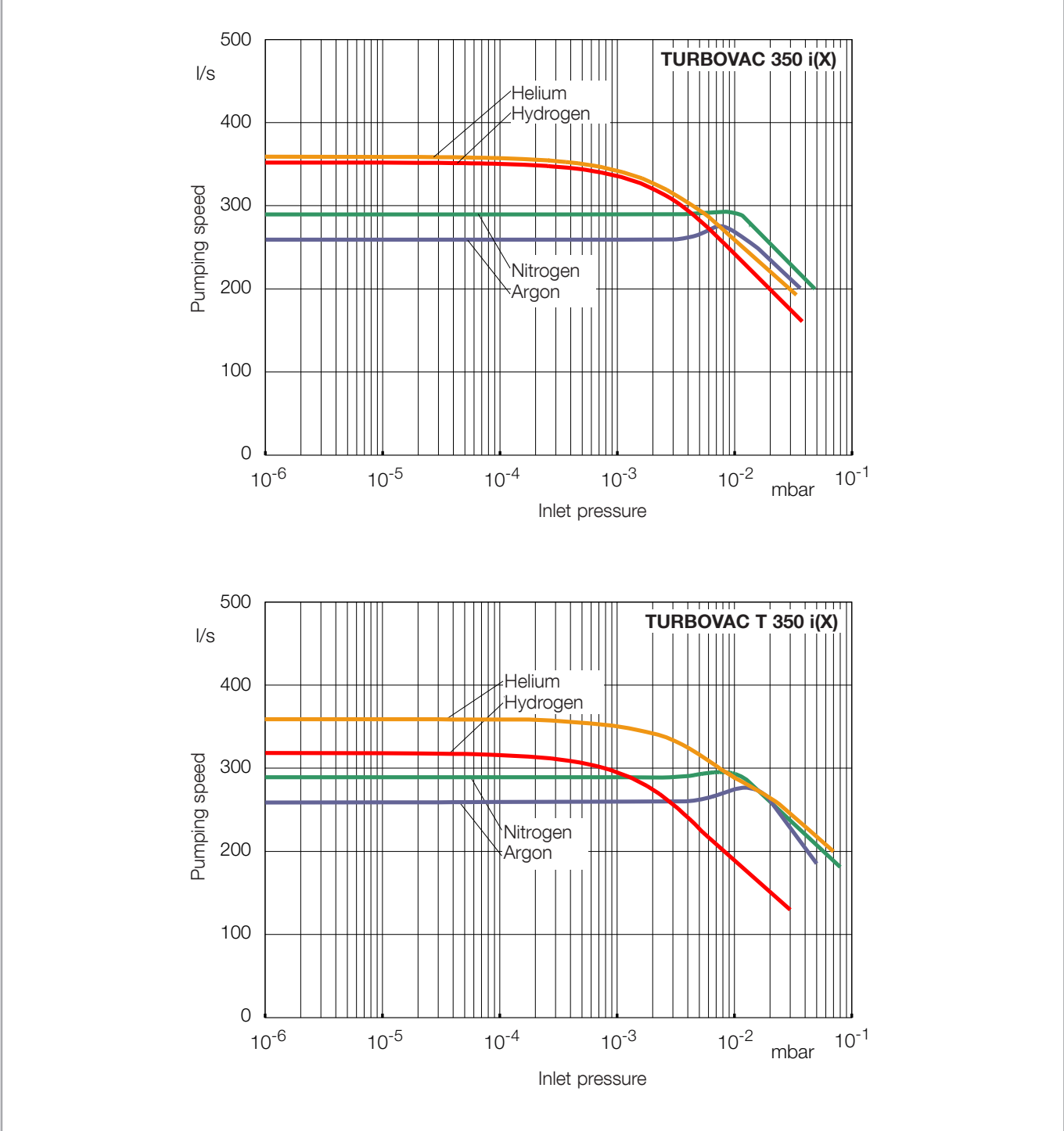

Fig. 1.7 Pumping speed curves for the TURBOVAC 350 i(X) and the TURBOVAC T 350 i(X)

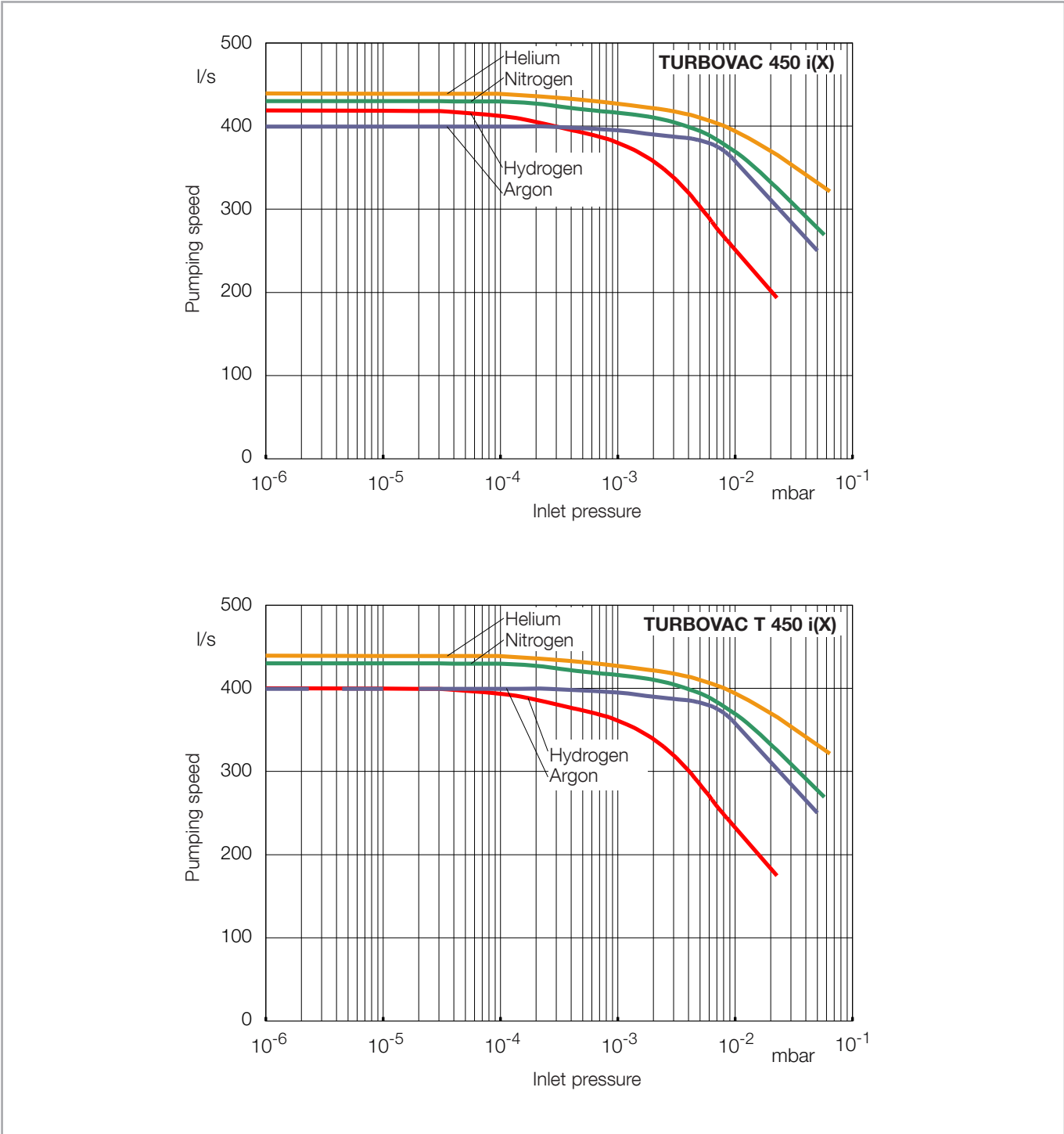

Fig. 1.8 Pumping speed curves for the TURBOVAC 450 i(X) and the TURBOVAC T 450 i(X)

Description

1.3.1 Technical data for the integrated drive electronics

	TURBOVAC i Drive electronics	TURBOVAC iX Drive electronics and vacuum system control unit
Supply voltage	24/48 V DC \pm 10 %	24/48 V DC \pm 10 %
Max. current consumption	10 A at 24 V DC	10 A at 24 V DC
Max. power consumption	240 W	240 W
Interfaces	see ordering data	see ordering data
Residual ripple	< 3 %	< 3 %
Max. length of the DC cable (for variants with removable front end)	0,5 m	–
Max. contact rating of the relays	48 V, 0.5 A 24 V, 1.0 A	48 V, 0.5 A 24 V, 1.0 A
Overvoltage category	II	II
Contamination grade	2	2
Accessory connections	1 pc. M8 connector, 24 V DC	3 pcs M8 connector, 24 V DC
Maximum load rating for the 24 V DC outputs (powering accessories, e.g. cooling unit or valves)	24 V, max. 18 W	24 V, 12 W
Vacuum gauge head connection	–	15 pin Sub-D

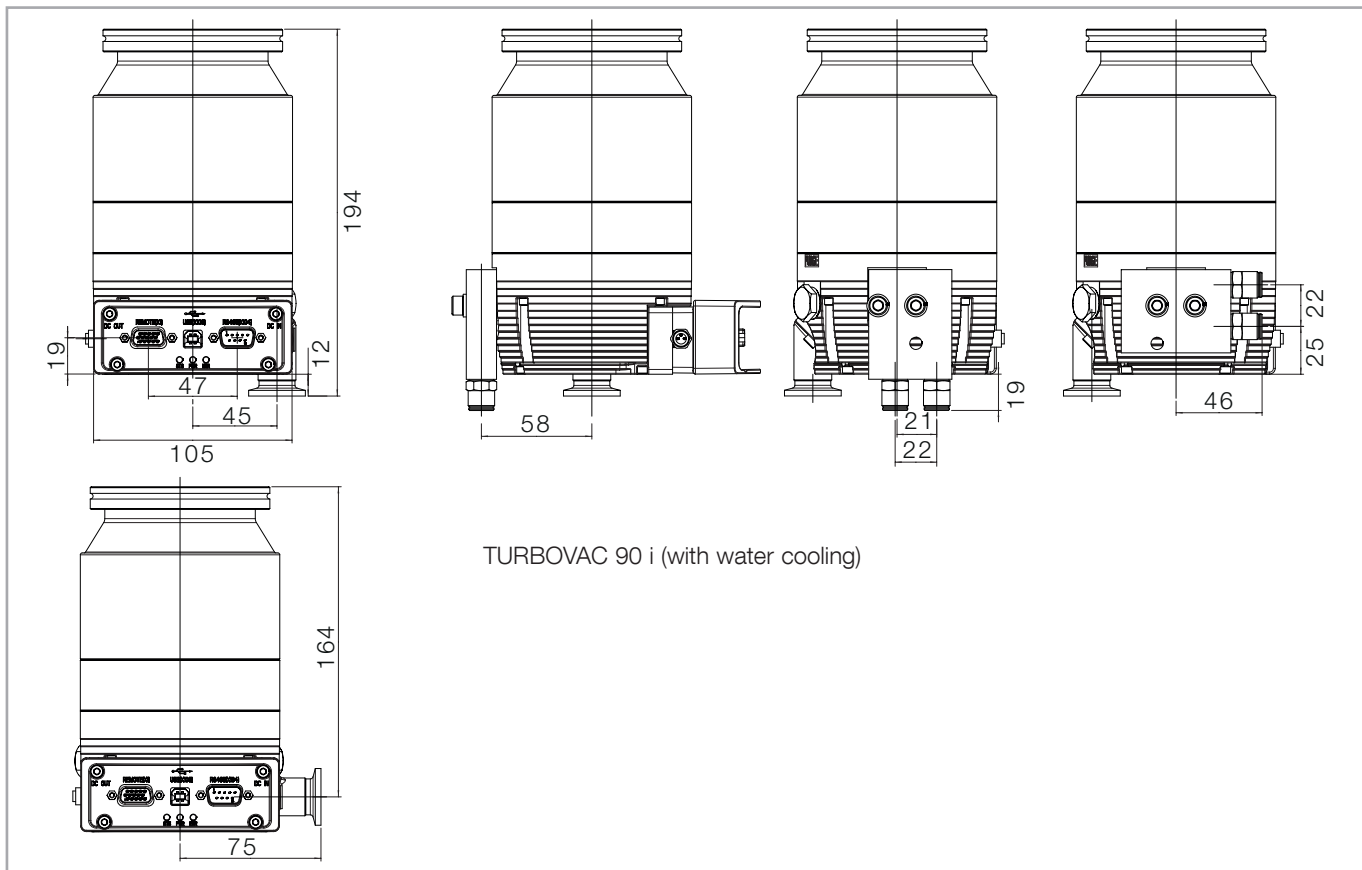

Fig. 1.9 Dimensional drawings, dimensions in mm

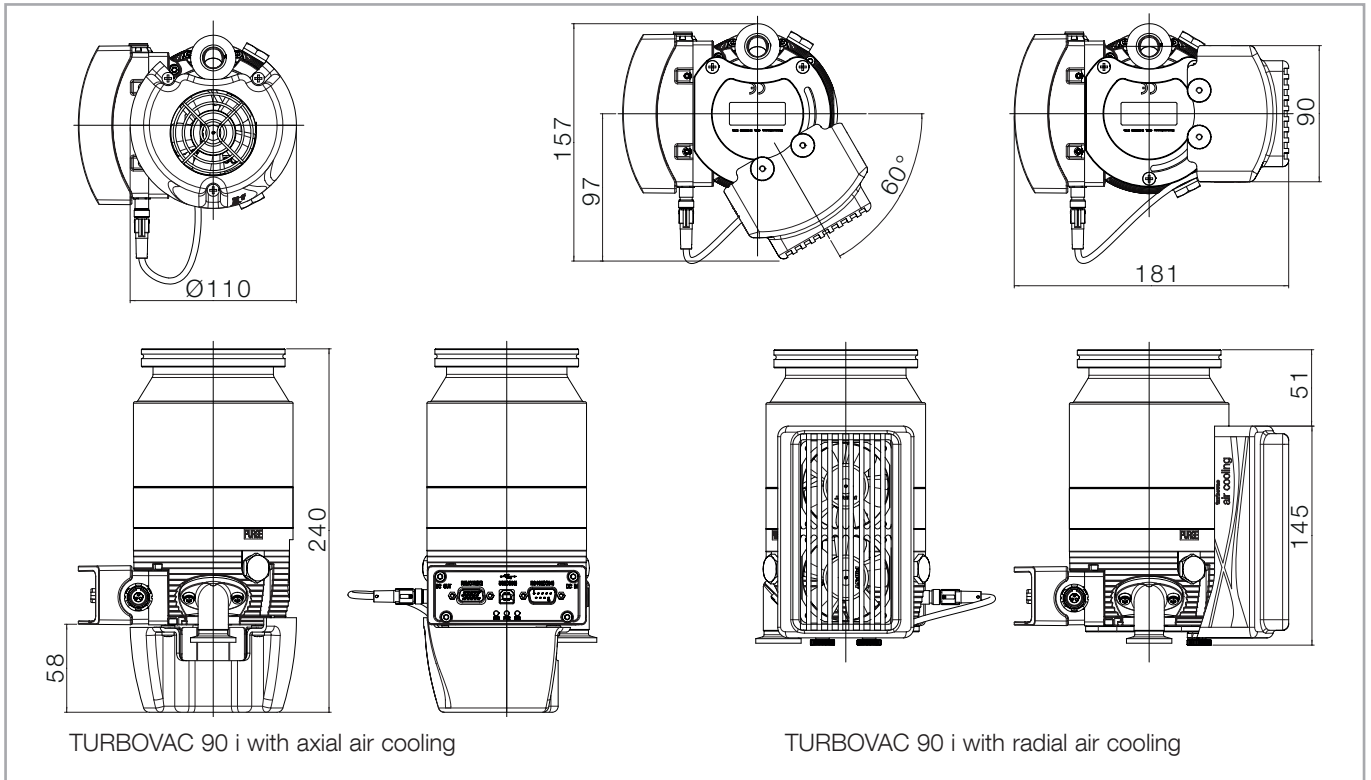

Fig. 1.10 Dimensional drawings, dimensions in mm

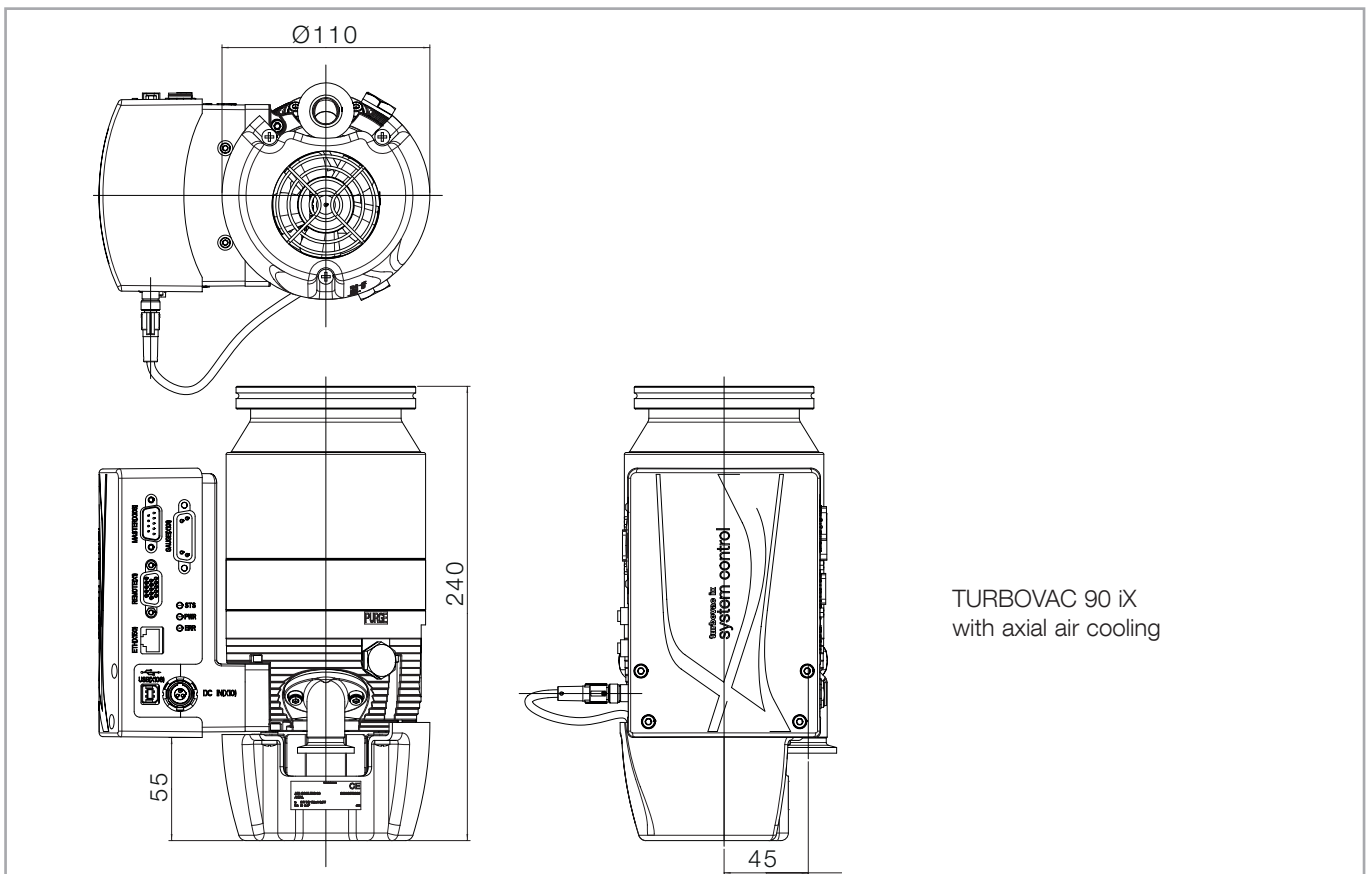

Fig. 1.11 Dimensional drawings, dimensions in mm

Description

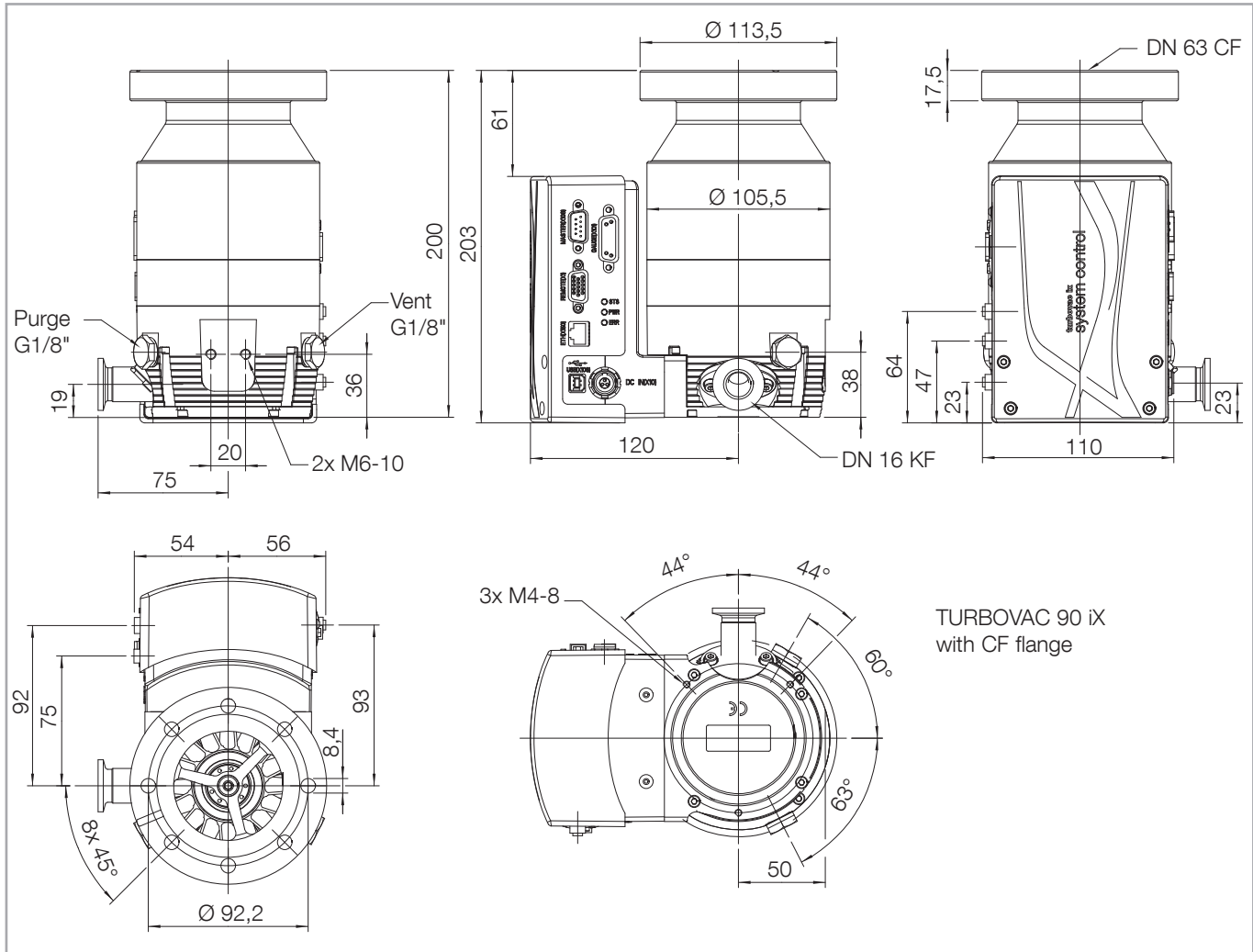

Fig. 1.12 Dimensional drawings, dimensions in mm

Description

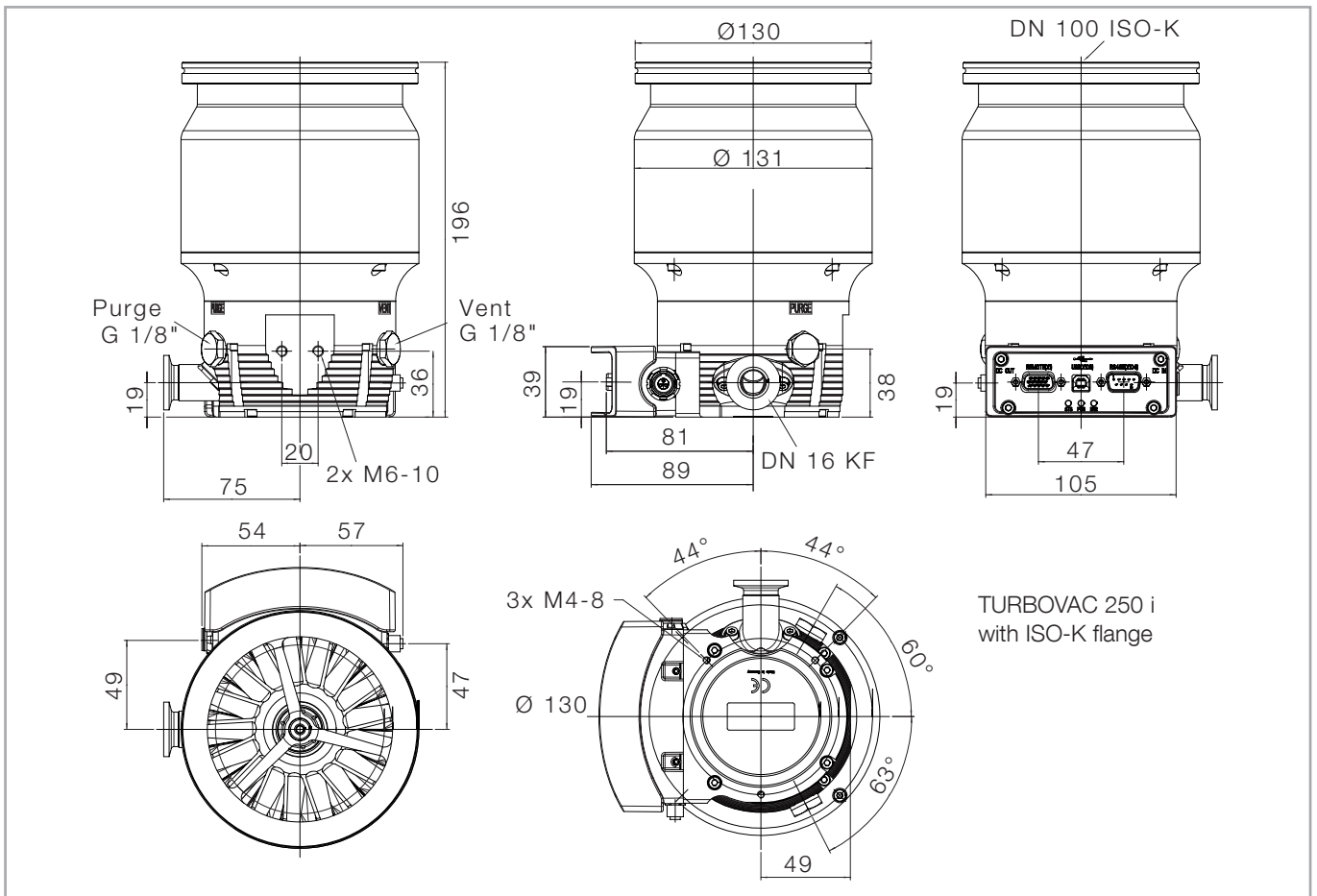

Fig. 1.13 Dimensional drawings, dimensions in mm

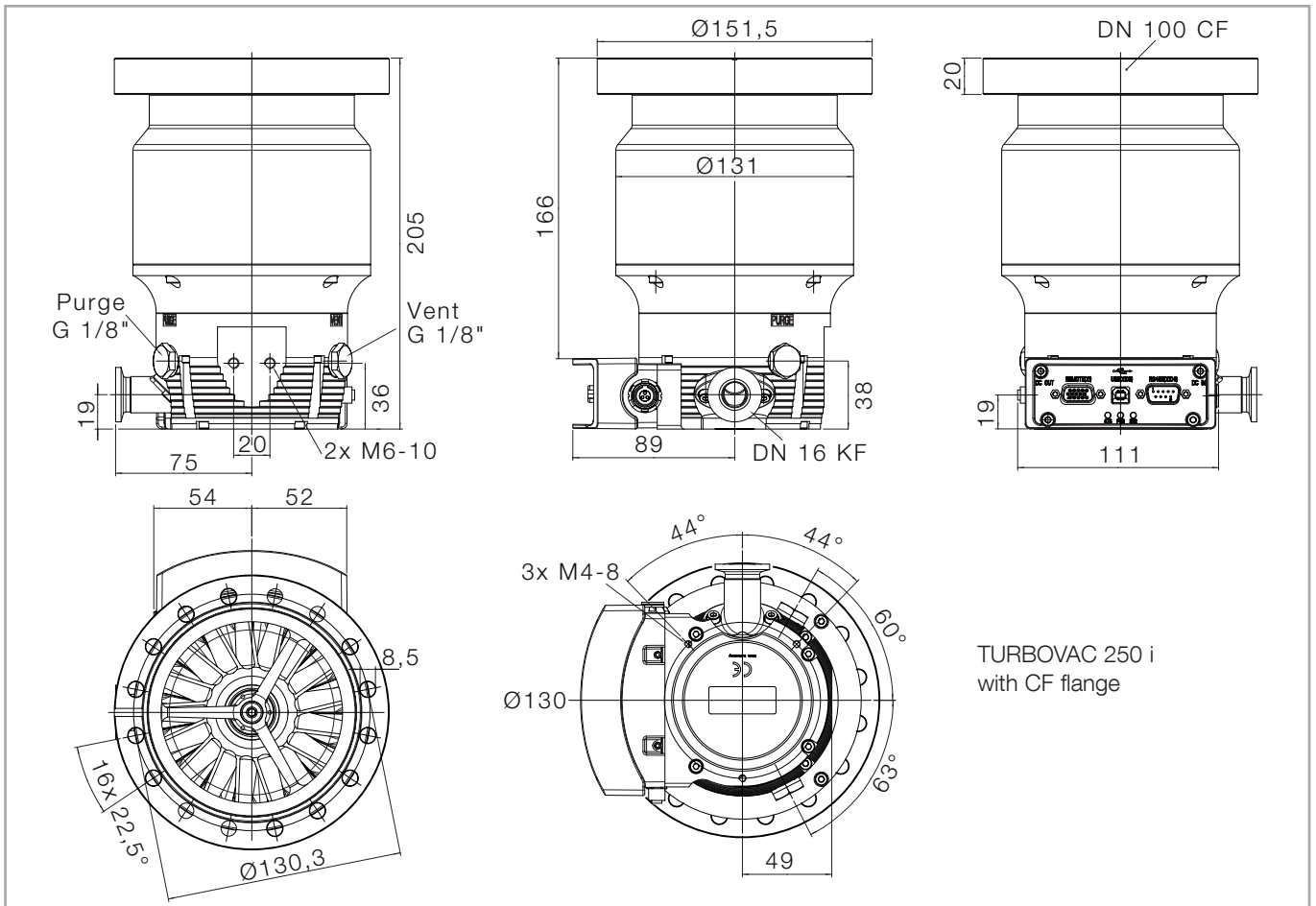
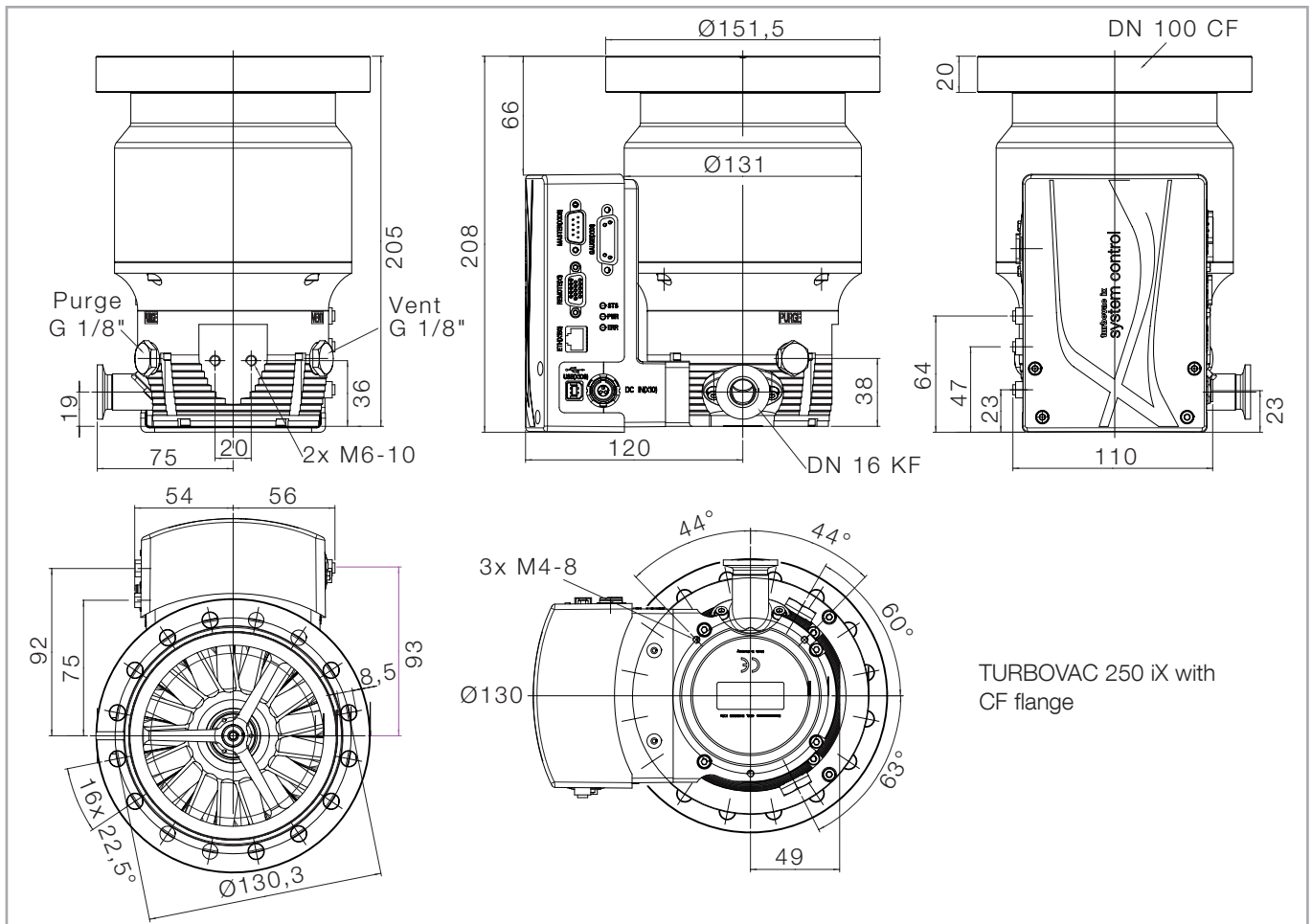
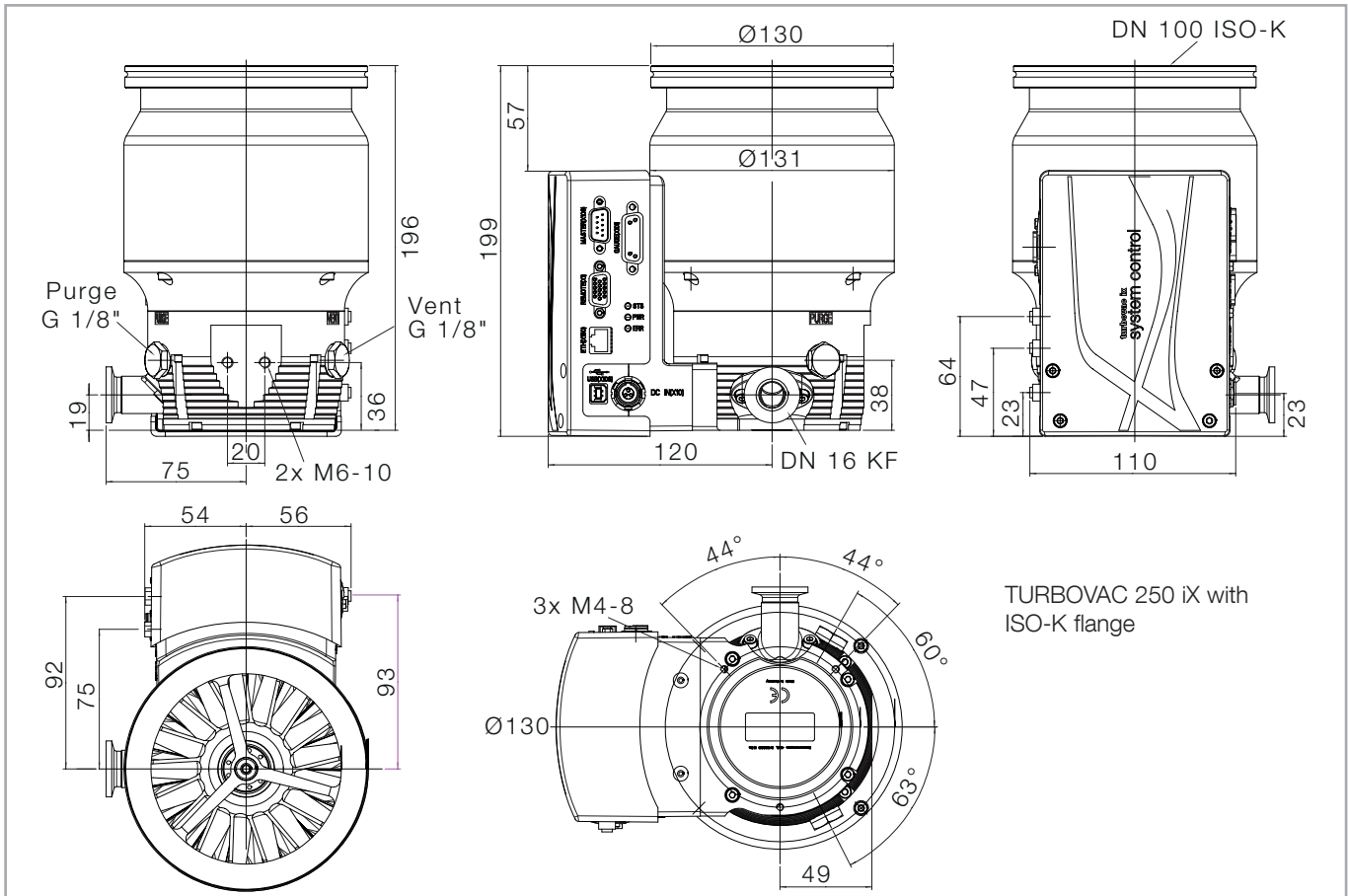

Fig. 1.14 Dimensional drawings, dimensions in mm

Description



Description

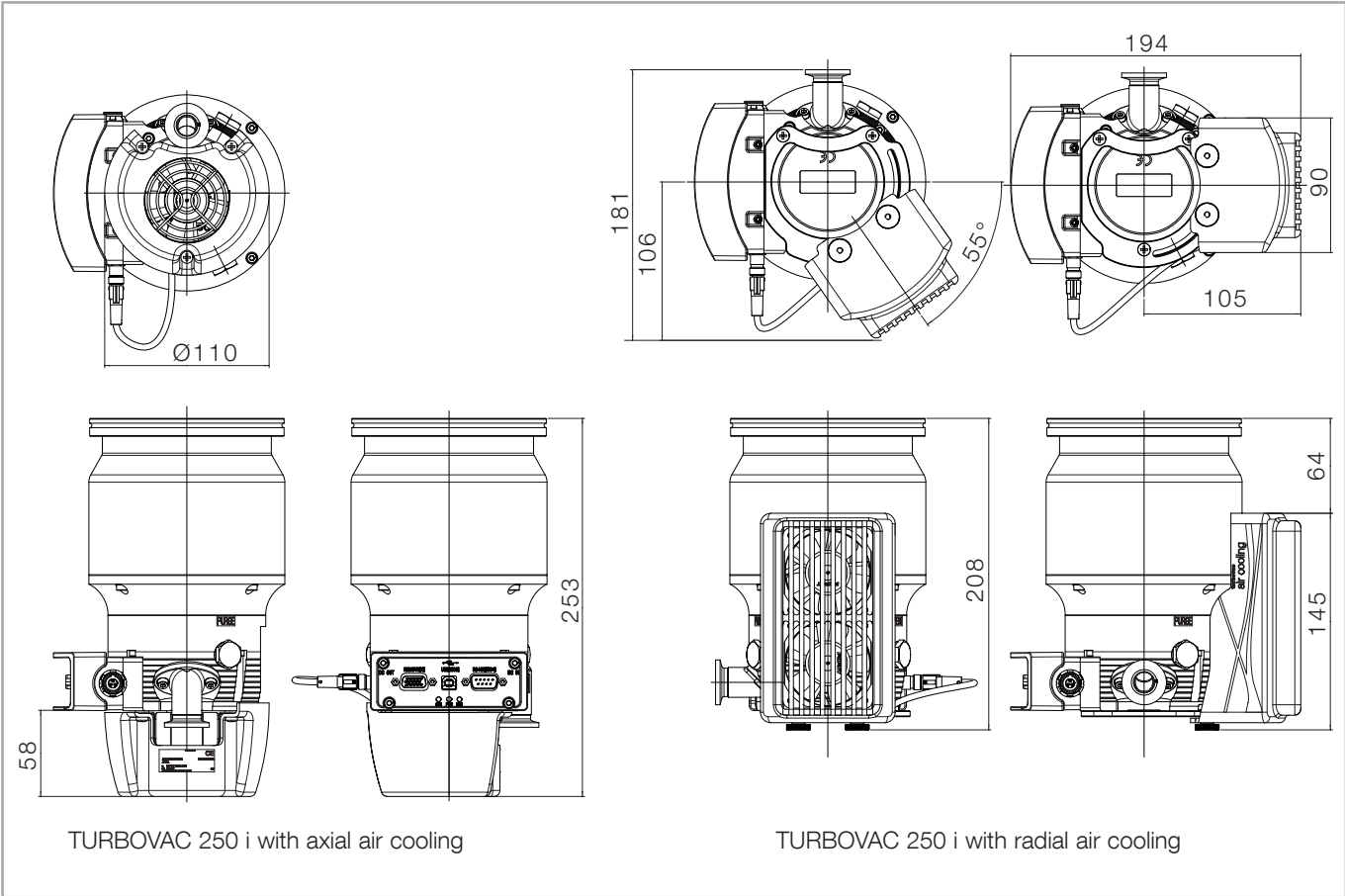

Fig. 1.17 Dimensional drawings, dimensions in mm

Description

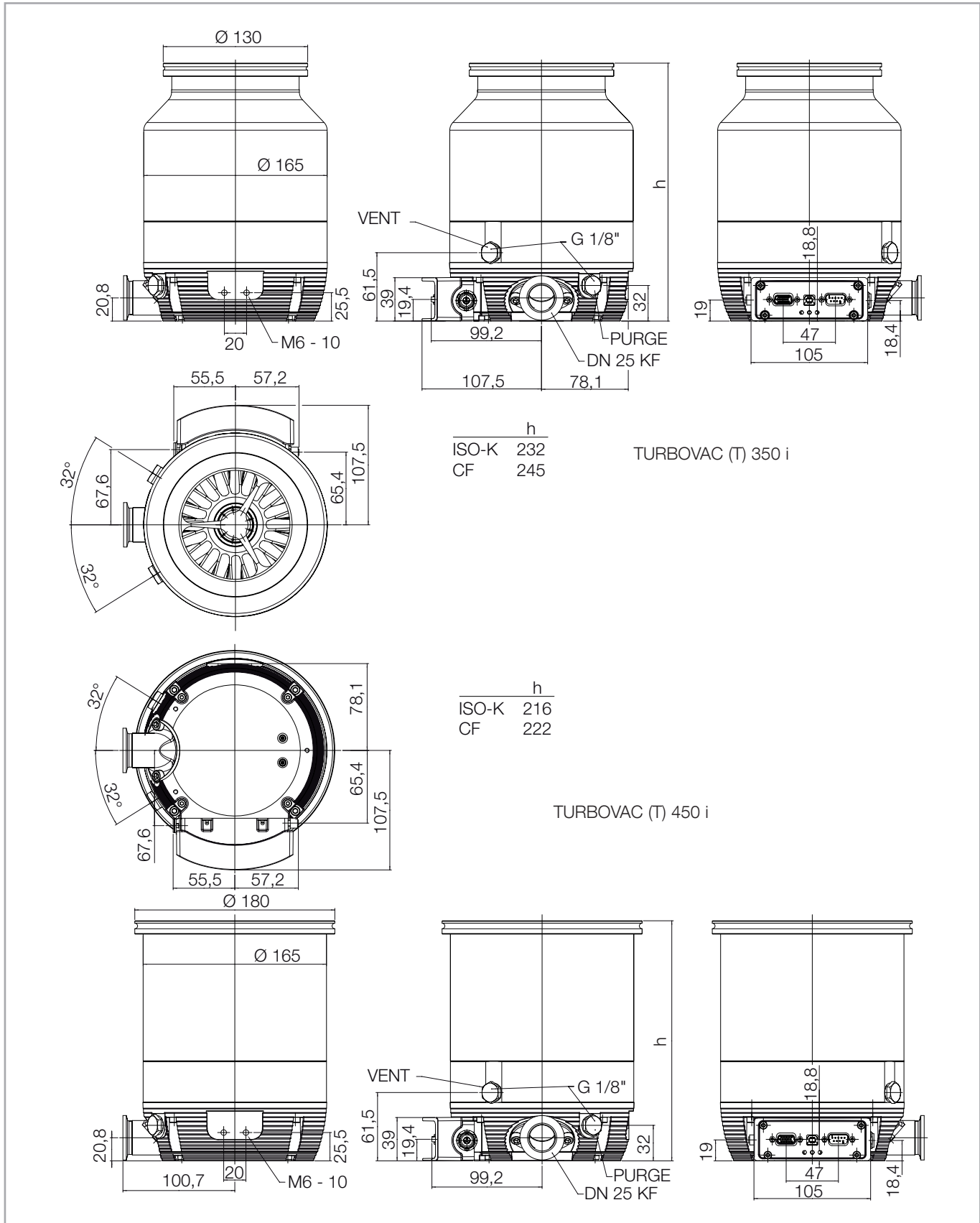

Fig. 1.18 Dimensional drawings, dimensions in mm

Description

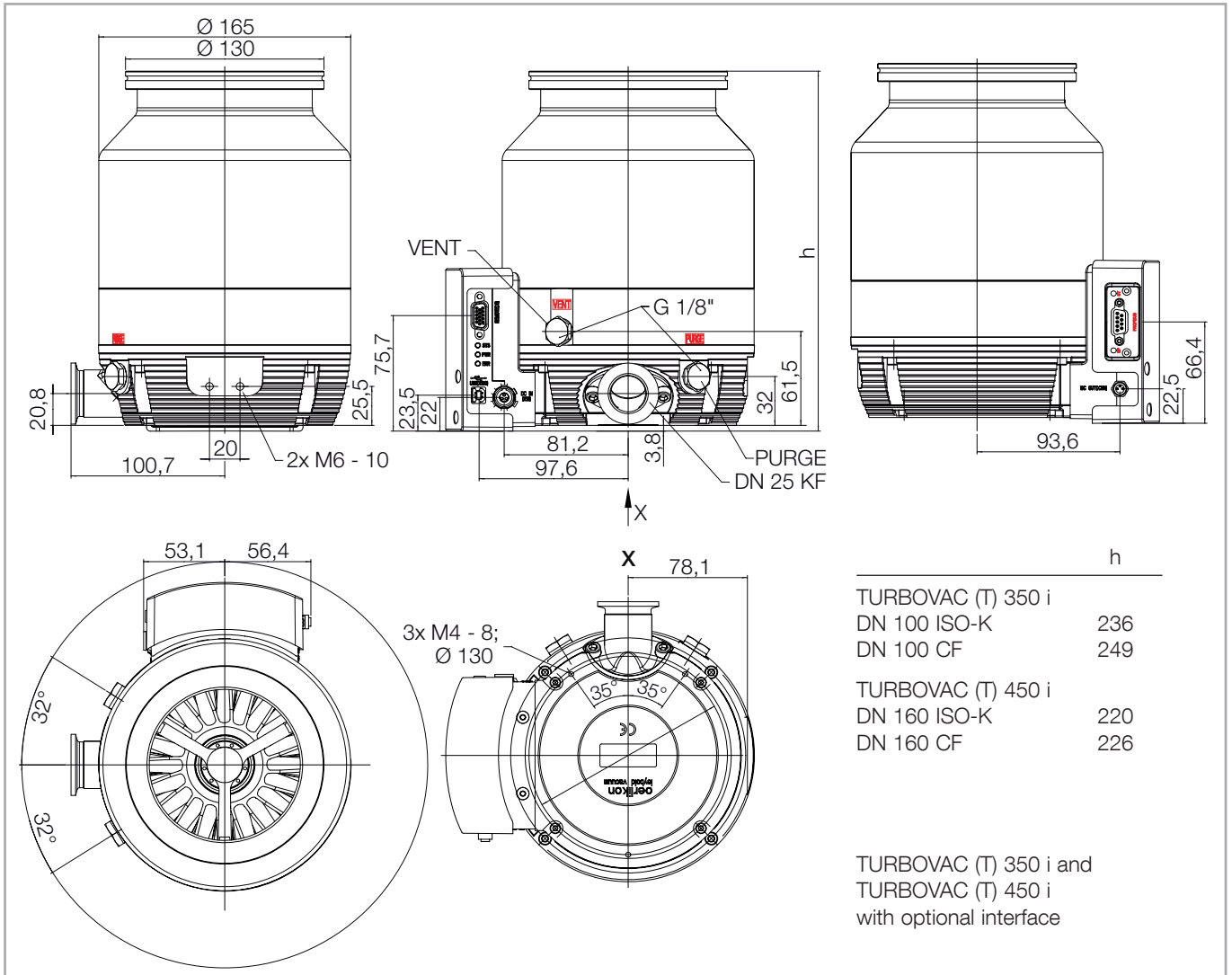

Fig. 1.19 Dimensional drawings, dimensions in mm

Description

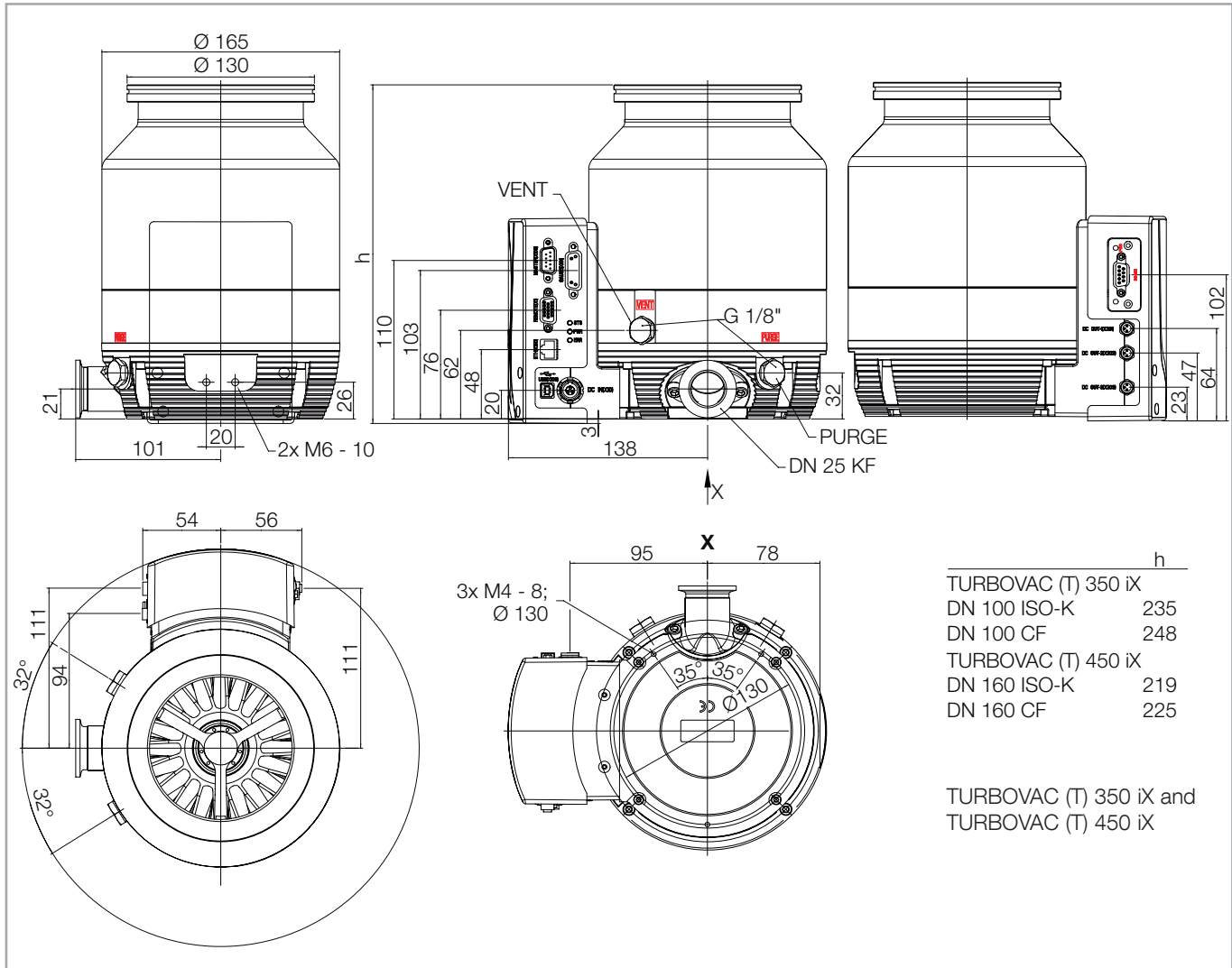

Fig. 1.20 Dimensional drawings, dimensions in mm

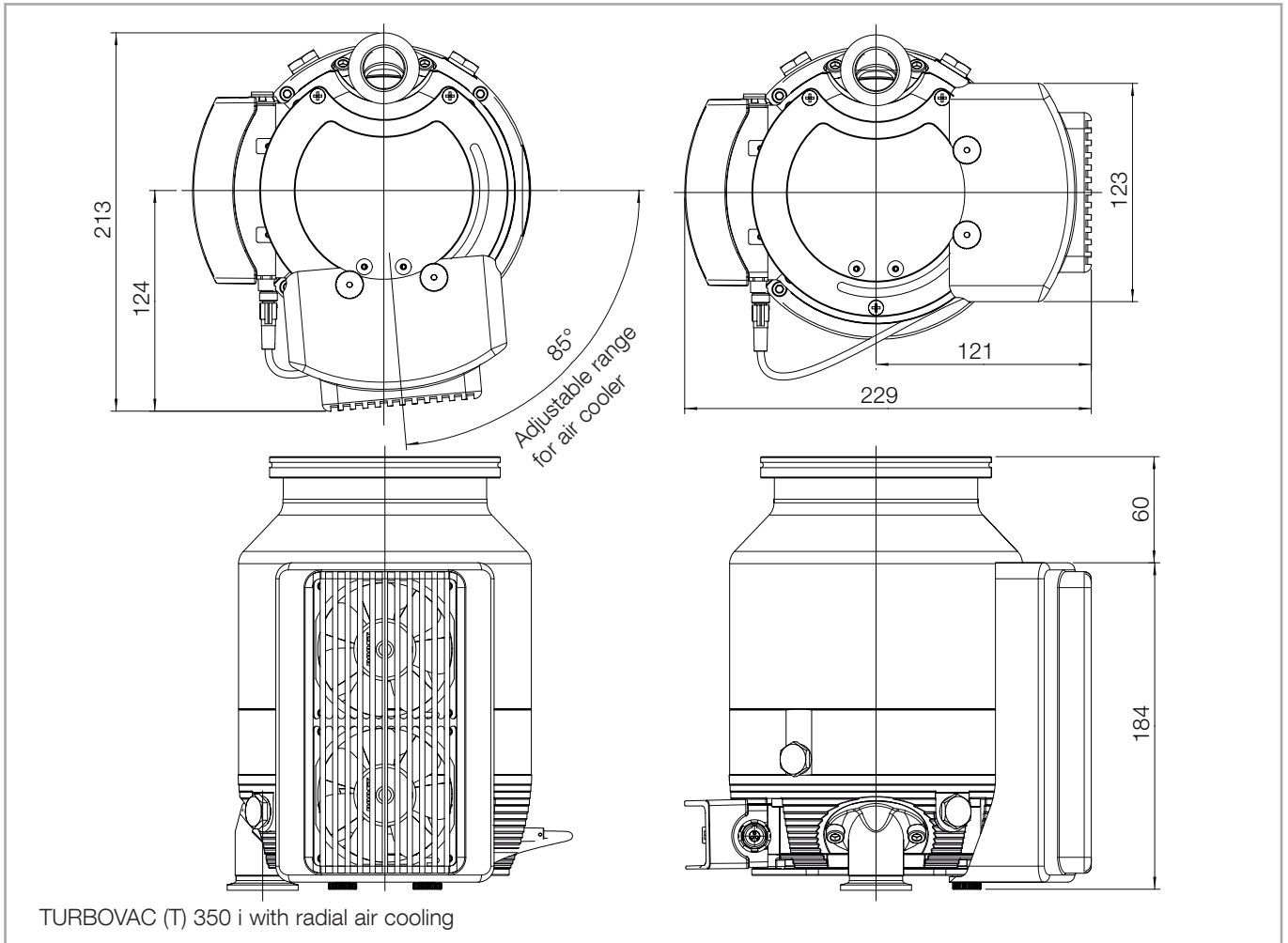

Fig. 1.21 Dimensional drawings

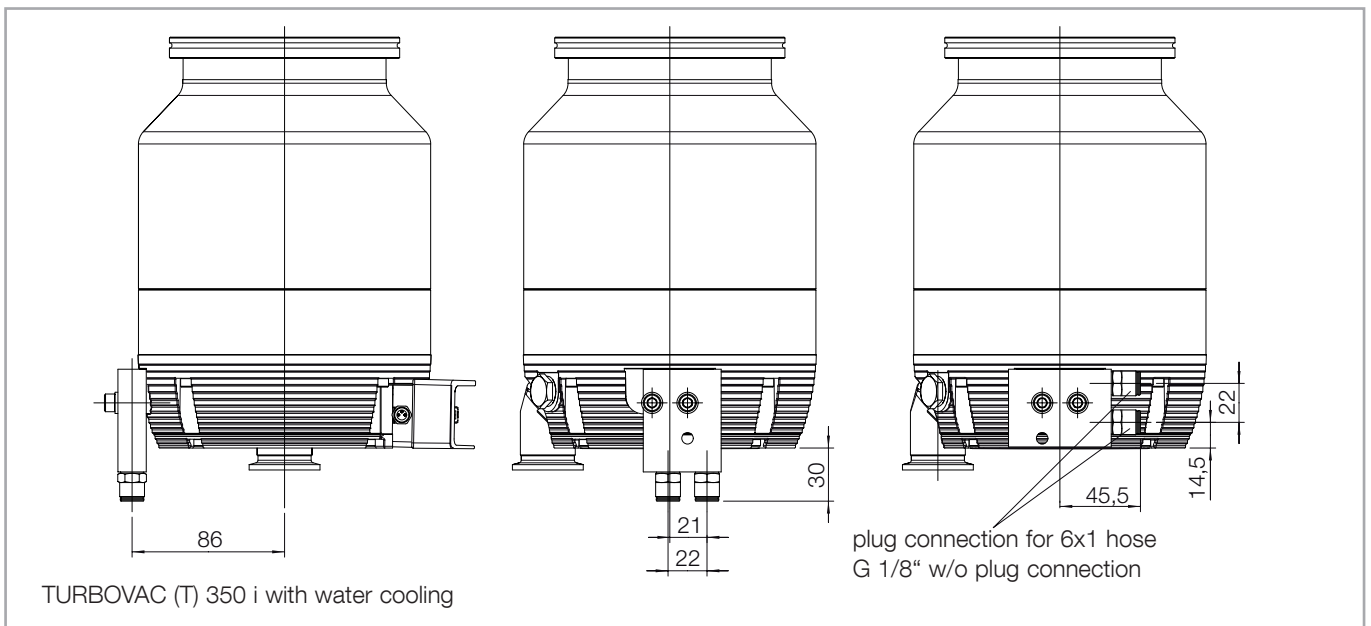

Fig. 1.22 Dimensional drawings

Description

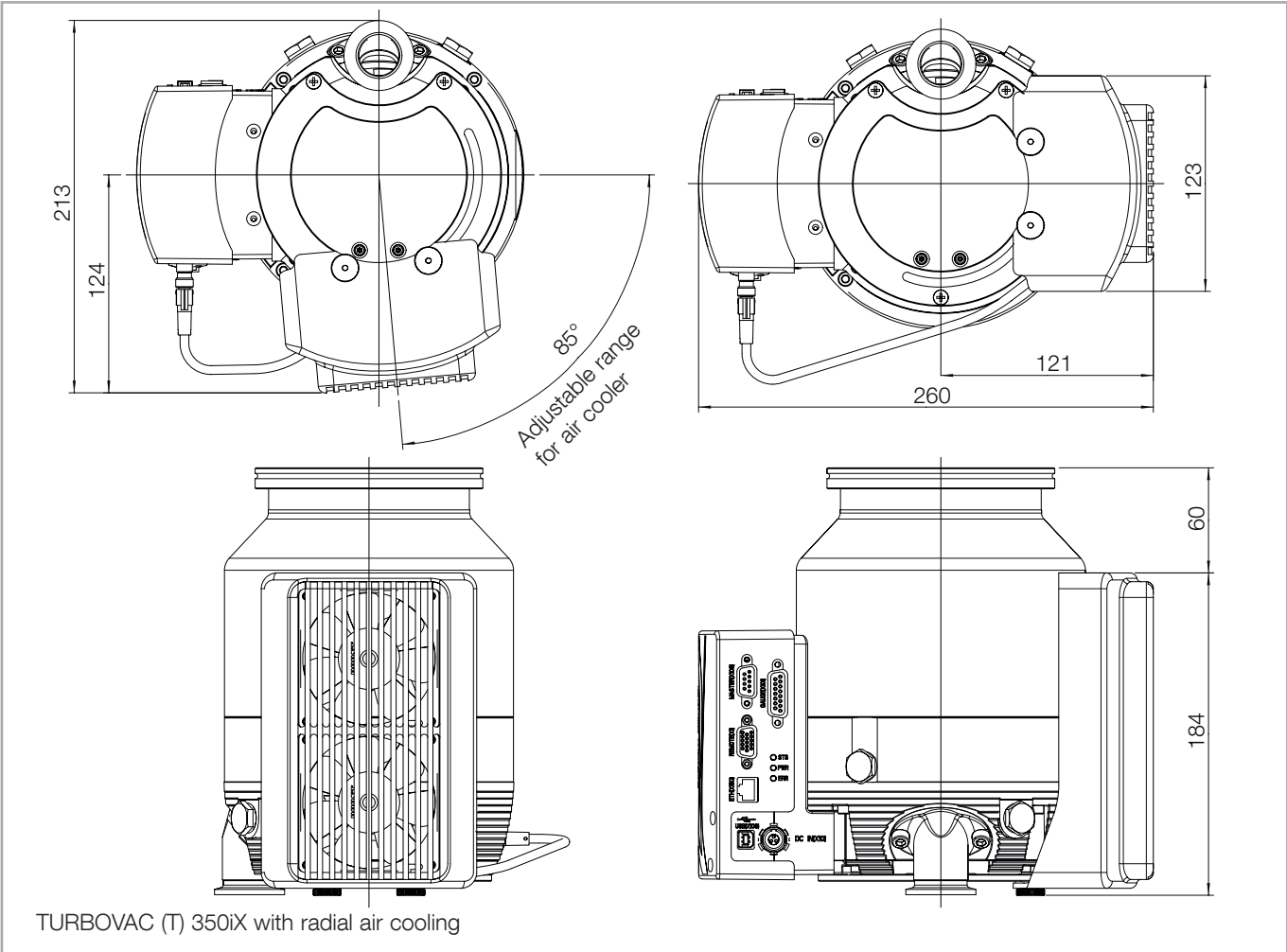

Fig. 1.23 Dimensional drawings

Description

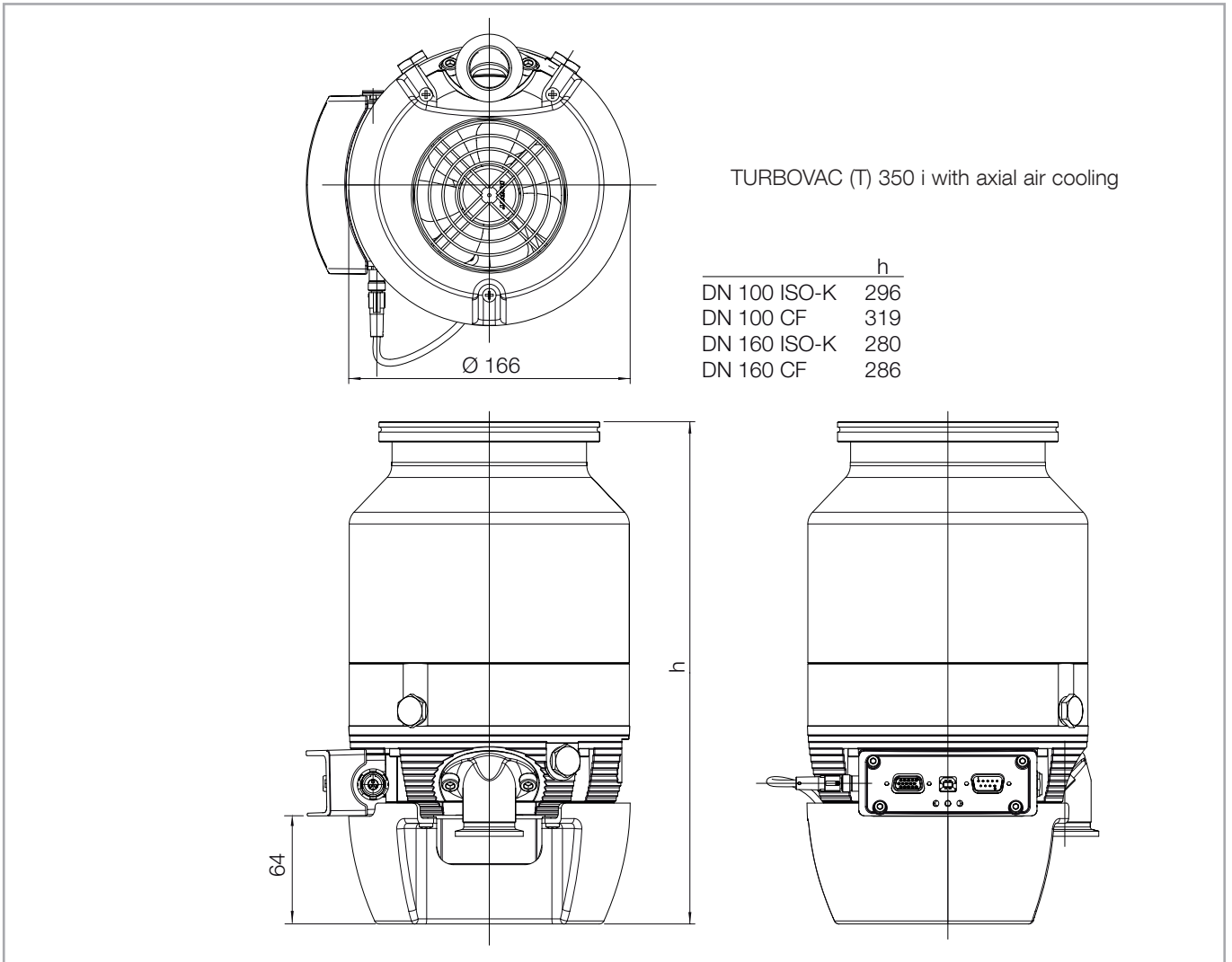

Fig. 1.24 Dimensional drawings

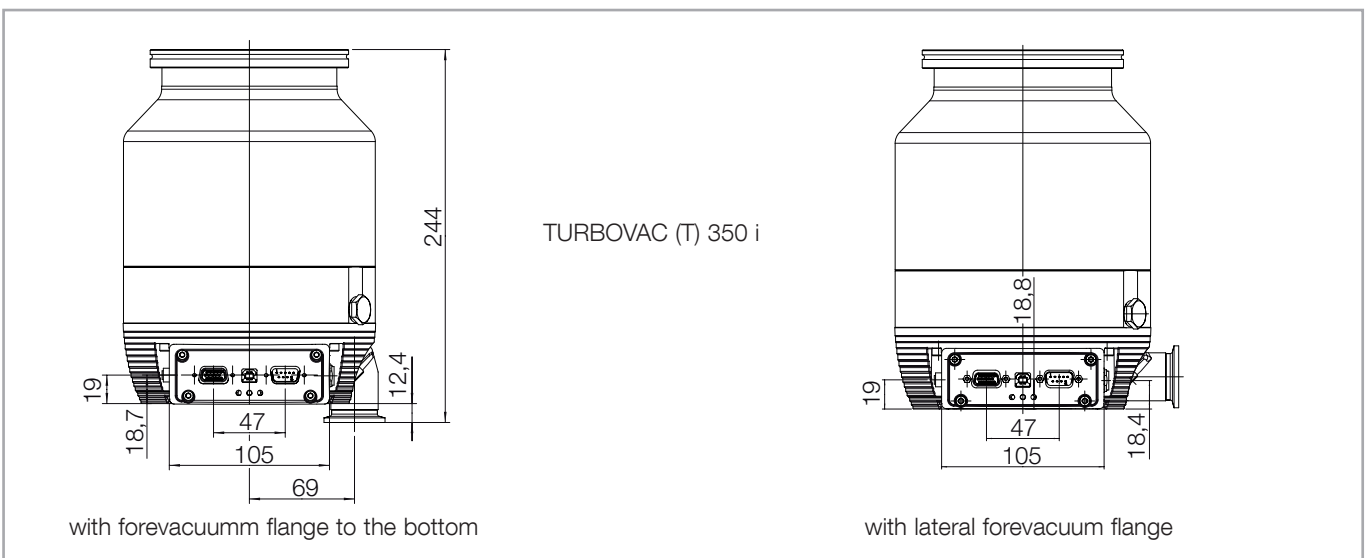

Fig. 1.25 Dimensional drawings

Description

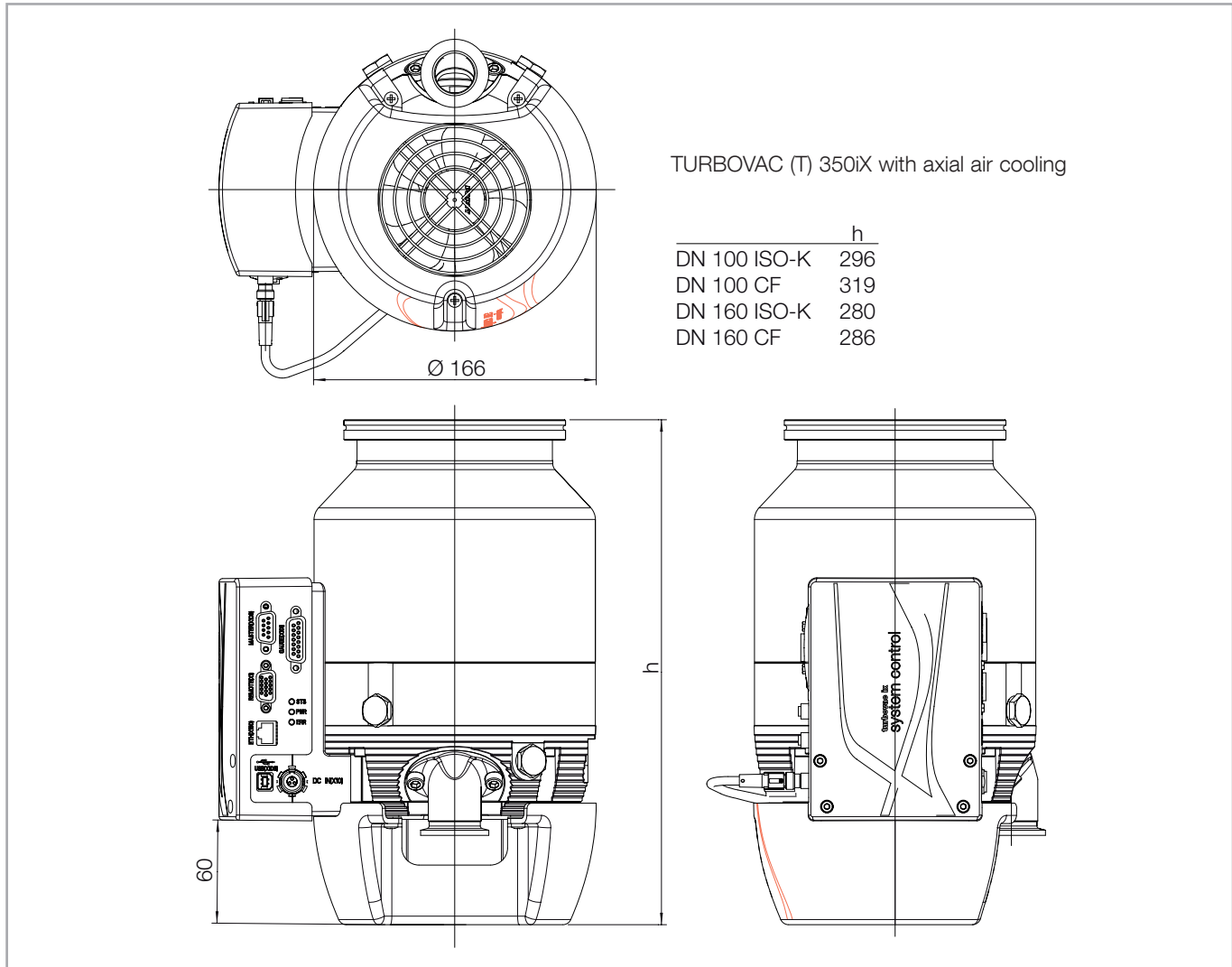

Fig. 1.26 Dimensional drawings

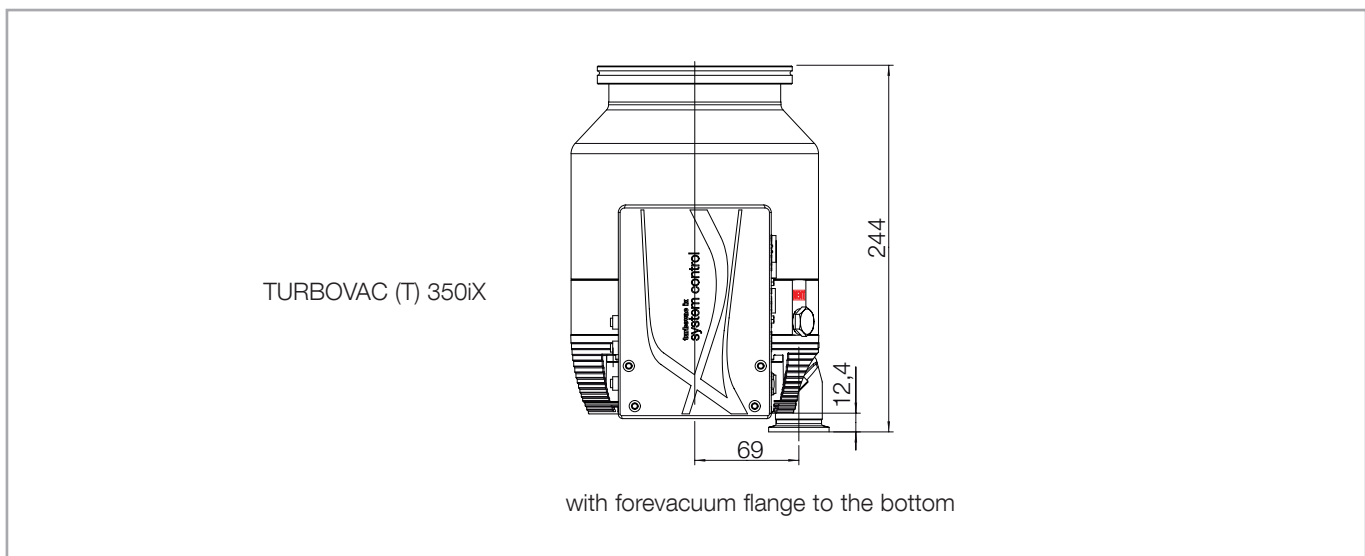

Fig. 1.27 Dimensional drawings

1.4 Ordering data

TURBOVAC	90 i	250 i
RS 485, USB+, 15-pin digital I/O interface		
High-vacuum flange	63 ISO-K	100 ISO-K
Part No.	810031V1000	820051V1000
High-vacuum flange	63 CF	100 CF
Part No.	810041V1000	820061V1000
High-vacuum flange	40 KF	
Part No.	810011V1000	

RS 232, USB+, 15-pin digital I/O interface		
High-vacuum flange	63 ISO-K	100 ISO-K
Part No.	810031V2100	820051V2100

TURBOVAC	90 iX	250 iX
RS 485, USB+, 15-pin digital I/O interface		
High-vacuum flange	63 ISO-K	100 ISO-K
Part No.	810031V3300	820051V3300
High-vacuum flange	63 CF	100 CF
Part No.	810041V3300	820061V3300

TURBOVAC	350 i	T 350 i	450 i	T 450 i
RS 485, USB+, 15-pin digital I/O interface				
High-vacuum flange	100 ISO-K	100 ISO-K	160 ISO-K	160 ISO-K
Part No.	830051V1000	830050V1000	830071V1000	830070V1000
High-vacuum flange	100 CF	100 CF	160 CF	160 CF
Part No.	830061V1000	830060V1000	830081V1000	830080V1000



Optional interface (RS 232, Profibus), USB+, 15-pin digital I/O interface: on request

TURBOVAC	350 iX	T 350 iX	450 iX	T 450 iX
USB+, 15-pin digital I/O interface				
High-vacuum flange	100 ISO-K	100 ISO-K	160 ISO-K	160 ISO-K
Part No.	830051V3000	830050V3000	830071V3000	830070V3000
High-vacuum flange	100 CF	100 CF	160 CF	160 CF
Part No.	830061V3000	830060V3000	830081V3000	830080V3000

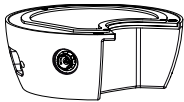
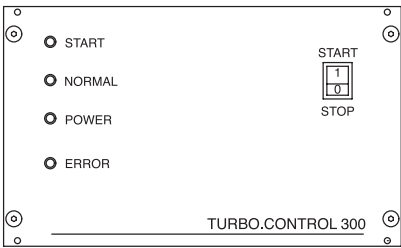

RS 485, USB+, 15-pin digital I/O interface				
High-vacuum flange	100 ISO-K	100 ISO-K	160 ISO-K	160 ISO-K
Part No.	830051V3300	830050V3300	830071V3300	830070V3300
High-vacuum flange	100 CF	100 CF	160 CF	160 CF
Part No.	830061V3300	830060V3300	830081V3300	830080V3300

Description

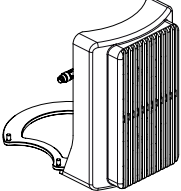
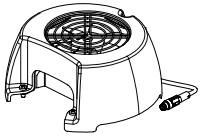
1.5 Accessories

	Part No.	
Power supply TURBO.POWER integra incl. 0.3 m cable	800100V0003	
Cable TURBOVAC i/iX - TURBO.POWER integra, 1 m	800096V0100	
Cable TURBOVAC i/iX - TURBO.POWER integra, 3 m	800096V0300	
Cable TURBOVAC i/iX - TURBO.POWER integra, 5 m	800096V0500	
Power supply and control unit TURBO.CONTROL 300	800100V0001	
Cable TURBOVAC - Turbo.Control 300, 1 m	800092V0100	
Cable TURBOVAC - Turbo.Control 300, 3 m	800092V0300	
Cable TURBOVAC - Turbo.Control 300, 5 m	800092V0500	
Cable TURBOVAC - Turbo.Control 300, 10 m extension	800092V1000	
Cable TURBOVAC - Turbo.Control 300, 20 m extension	800092V2000	
Mains cable for power supplies, 3 m long		
EC plug	800102V0002	
UK plug	800102V0003	
US plug	800102V1002	
24/48 V DC In plug TURBOVAC	800090V0000	
TURBOVAC i DC cable with bare wire ends, 1 m	800095V0100	
TURBOVAC i DC cable with bare wire ends, 3 m	800095V0300	
TURBOVAC i DC cable with bare wire ends, 5 m	800095V0500	
Accessory cable TURBOVAC i, M8-M8, 2 m	800110V0016	
Y cable TURBOVAC i, M8	800110V0020	
Start stop switch for TMP	800110V0021	
USB cable 2.0 Type A/B, 1.8 m	800110V0108	
Relay box for forevacuum pump, 1-phase, 10A incl. 2 m M8-M8 cable	800110V0030	
LEYASSIST software for TMPs (included in the standard equipment for TURBOVAC iX)	230439V01	
Air cooling radial		
TURBOVAC 90 i(X)	800136V0007	
TURBOVAC 250 i(X)	800136V0009	
TURBOVAC 350-450 i(X)	800136V0005	
Air cooling axial		
TURBOVAC 90 i(X) and 250 i(X)	800136V0008	
TURBOVAC 350-450 i(X)	800136V0006	

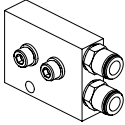
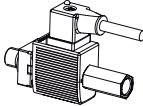
Description

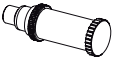
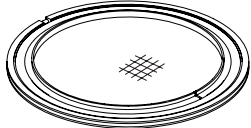
	Part No.	
Water cooling TURBOVAC i(X), hose 6x1, G 1/8"	800135V0005	
Water cooling TURBOVAC i(X), hose 1/4"	800135V0006	
Venting valve, 24 V DC, G 1/8"	800120V0012	
Power failure venting valve 24 V DC, G 1/8"	800120V0022	
Purge gas valve, 24 V DC, G 1/8", 24 sccm	800120V0013	
Purge gas throttle 24 sccm	800120V0014	
Air filter for TMP, G 1/8"	800110V0022	
Air drier TURBOVAC	auf Anfrage	
Flange heater DN 63 CF, 230V	800137V0003	
Flange heater DN 63 CF, 115V	800137V0004	
Flange heater DN 100 CF, 230V	800137V0005	
Flange heater DN 100 CF, 115V	800137V0006	
Flange heater DN 160 CF, 230V	800137V0007	
Flange heater DN 160 CF, 115V	800137V0008	
Vibration absorber DN 100 ISO-K for other flanges	800131V1100 on request	
Centering ring with coarse inlet screen DN 63 ISO-K	800133V0011	
Centering ring with splinter guard DN 63 ISO-K	800133V0012	
Centering ring with coarse inlet screen DN 100 ISO-K	800133V0021	
Centering ring with splinter guard DN 100 ISO-K	800133V0022	
Centering ring with coarse inlet screen DN 160 ISO-K	800133V0031	
Centering ring with splinter guard DN 160 ISO-K	800133V0032	
Coarse inlet screen DN 63 CF (3.2 mm)	800132V0011	
Splinter guard DN 63 CF (0.8 mm)	800132V0012	
Coarse inlet screen DN 100 CF (3.2 mm)	800132V0021	
Splinter guard DN 100 CF (0.8 mm)	800132V0022	
Coarse inlet screen DN 160 CF (3.2 mm)	800132V0031	
Splinter guard DN 160 CF (0.8 mm)	800132V0032	

Description

	Part No.
Mounting kit TURBOVAC	
DN 63 ISO-K	800134V0010
DN 63 CF	800134V0011
DN 100 ISO-K	800134V0020
DN 100 CF	800134V0021
DN 100 ISO-K to ISO-F	800134V0025
DN 160 ISO-K	800134V0030
DN 160 CF	800134V0031
DN 160 ISO-K to ISO-F	800134V0035

Transport and storing

2 Transport and storing

Remove the equipment from the transportation box and keep the packaging. Make sure that the product has not been damaged during transportation. If this unit is damaged contact your carrier and inform Leybold if necessary. For storage of the product, use the packaging provided.

Be careful not to damage the sockets and connections during transportation

Do not stand below the pump while connecting or removing the turbomolecular pump.

The turbomolecular pump is shipped in a sealed PE bag with desiccant. Do not open the sealed package until immediately before installing.

Do not remove the covers and blanking flanges until you are ready to make the connections, to ensure that the turbomolecular pump is installed under the cleanest possible conditions.

Do not store pump and accessories in a moist atmosphere so as to prevent these items from suffering corrosion.

NOTICE



WARNING



3 Installation

3.1 Conforming utilization

The turbomolecular pump is intended for generating a vacuum. It is suited for non-corrosive processes only.

The turbomolecular pump must be bolted to a rigid vacuum system and connected to a suitable backing pump.

It is intended for being operated within closed rooms.

The use of any accessories which have not been specified by Leybold is only allowed after approval by Leybold.

3.1.1 Non-conforming utilization

Non-conforming utilizations for both pump and frequency converter are among others:

- Pumping of gases and vapours for which the materials of the pump are unsuitable.
- Operation in connection with processes in which GaAs (gallium arsenide) is being pumped.
- Pumping of gas mixtures with an oxygen content of > 21%.
- Pumping of corrosive gases and dust containing gases without reverting to purge gas operation.
- Pumping of condensable vapours without suitably controlling the temperature of the pump. Upon compression within the pump, these vapours may condense or form deposits.
- Pumping of dusts and solids without the use of suitable screens and filters.
- Operation at an inadmissibly high forevacuum pressure.
- Operation at inadmissibly high gas loads.
- Utilization of both pump and frequency converter in explosion hazard areas.
- Non-compliance of the specified maintenance and servicing intervals
- Operation of the pump and drive electronics in environments which demand protection type IP 40 or higher and where the installation site is over 4000 m the above sea level.
- Utilization in systems and pump systems in which the pressure may exceed 1.4 bar abs.
- Operation with an inadequately mounted pump
- Operation without having flanged the pump to the system or without having connected it to a suitable backing pump.
- Operation with additional heat sources involving thermal radiation, thermal conduction via the high vacuum or the forevacuum flange, strong magnetic fields or very hot process gases, for example. In environments with water cooling operation, CF flanges may be baked-out up to 100 °C.

- Use in systems in which impact stress and vibrations or periodically occurring forces affect pump, frequency converter and cables.
- Operation on moving system or system components (locks or movable pump systems, for example).
- Operation at vibration absorbers and vacuum components (gate valves, valves) which are not capable of sustaining the specified deceleration torque should the pump rotor seize.
- Stepping on pump, add-on parts, drive electronics, flanges and cables to climb onto the system.
- Fitting of add-on parts to the forevacuum flange which cause an inadmissible high load.
- Removing, covering or obstructing warning notices.
- Standstill or storing of the pump without suitable sealing-off and drying. Storing in a humid atmosphere can cause corrosion.
- Conversions, manipulations and maintenance work by personnel not authorised by Leybold..

Any non-conforming utilisation of pump, frequency converter and accessories can result in severe injury or death and cause damage to components.

WARNING

3.2 Operating environment

Permissible ambient temperature	5 to 45 °C no dripping or spraying water, no explosive gas atmospheres
Installation altitude	up to 4000 m At altitudes over 2000 m heat dissipation by the ambient air is impaired.

3.3 Fitting accessories

See also Section 1.5 accessories.

Various accessory components can be connected to the TURBOVAC i(X)

- Water cooling or air cooling, see Section 3.6.
- Purge gas valve, venting valve or power failure venting valve, see Sections 3.7 and 3.8
- Relay box for switching a forevacuum pump.

The accessory connections are pre-configured in the factory and are therefore ready for immediate operation when connecting the pre-configured accessory equipment.

Configurations may be modified via the interfaces. For this refer to the interface Operating Instructions.

Only for TURBOVAC i

Secondary devices are directly energised and activated via the accessory connection X201 (M8 plug); by means of a Y-cable 2 accessories can be connected at the same time.

In this case both devices will be switched parallelly (i.e. de-energised active / in-active). The factory-set accessories's interface features a plug-and-play mode, and is instantly ready for operation with the connected device (energised with pump switched on).

Only for TURBOVAC iX

Additional accessory components can be connected to the TURBOVAC iX

- Pressure gauge
- Further 24 V DC operated equipment which may be driven depending on the pump status.

The accessory components can be electrically powered and driven through three accessory connections. The following table shows the TURBOVAC iX configuration as delivered from the factory:

Accessory connection	Pre-configured equipment	Reaction
X201	Air cooling	Air cooling unit is running when the TURBOVAC is running.
X202	Relay box for forevacuum pump	Forevacuum pump is running when the TURBOVAC has received the start command.
X203	Venting valve	The venting valve opens when the start command is revoked and the frequency drops below 999 Hz. At 5 Hz the valve is closed again (no power failure venting!).

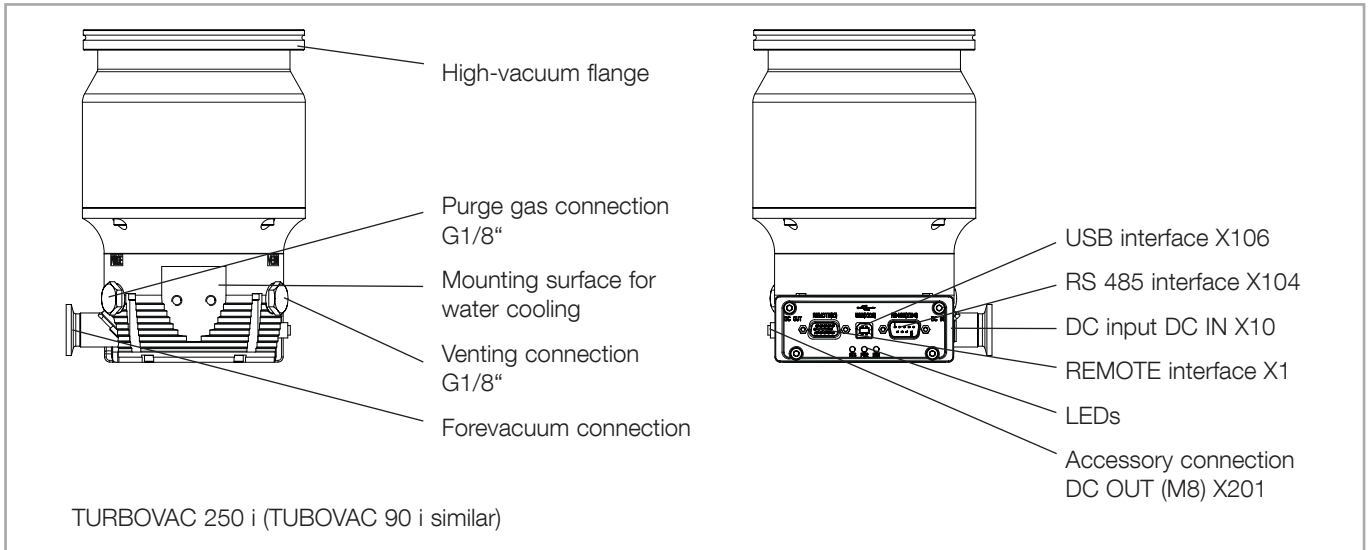

Fig. 3.1 Connections

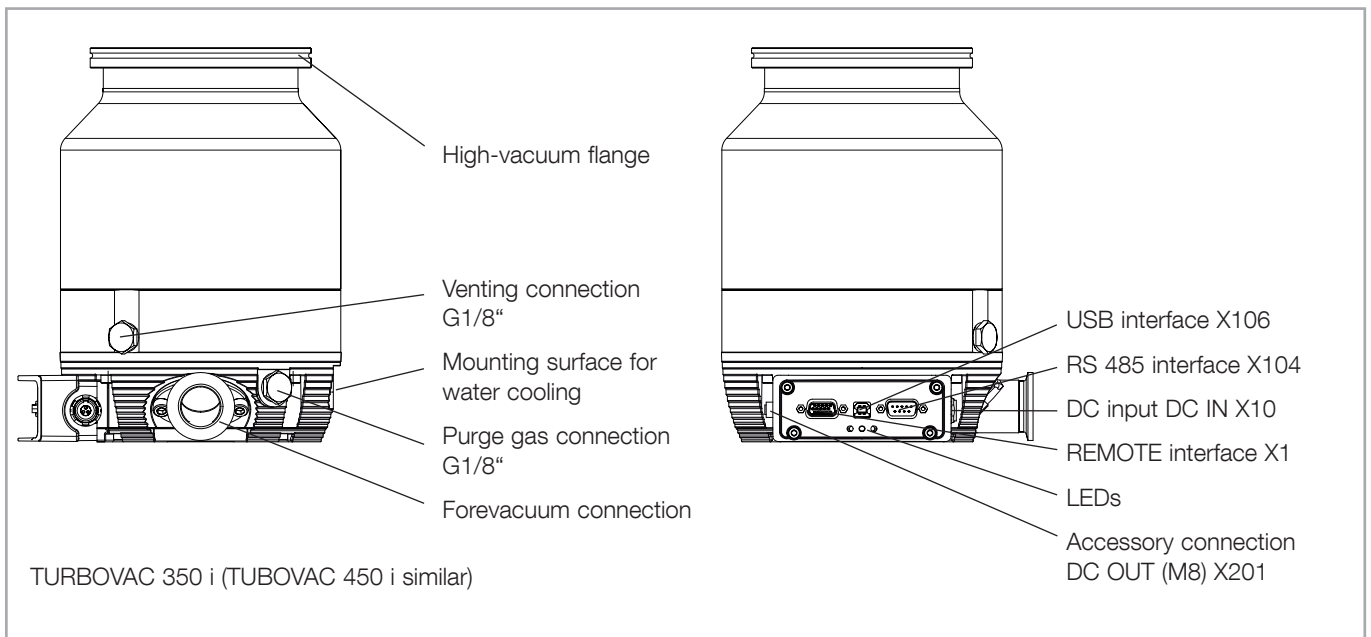

Fig. 3.2 Connections

Installation

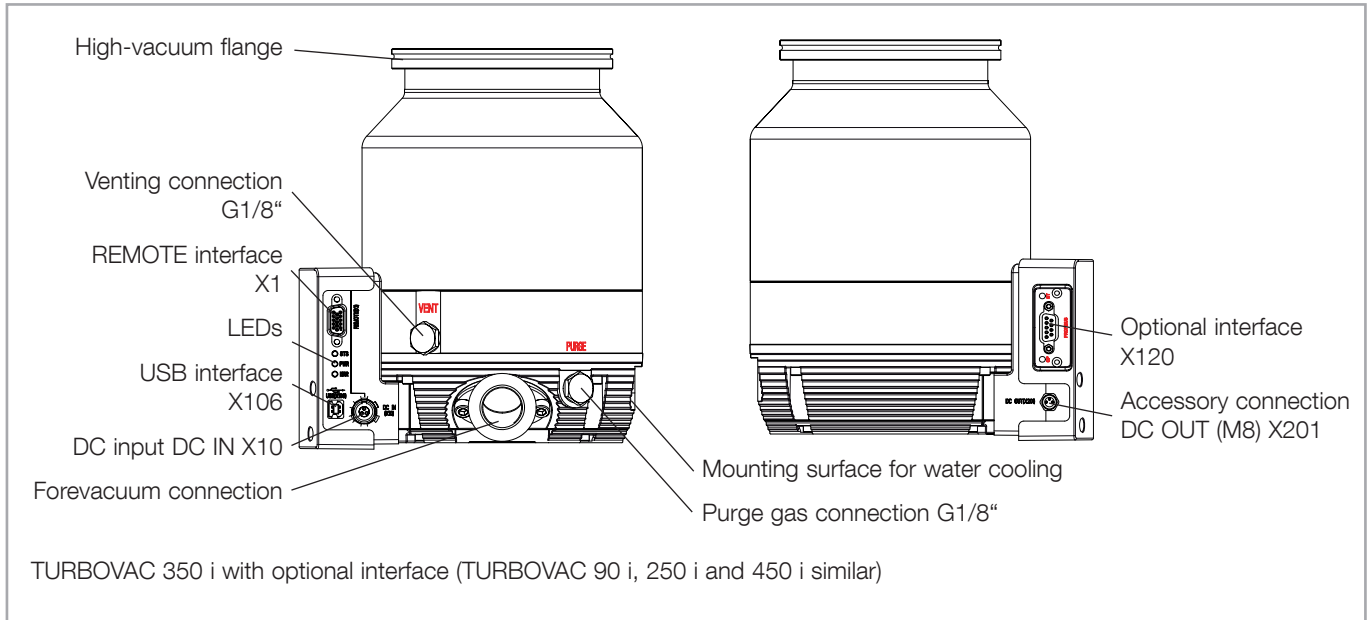

Fig. 3.3 Connections

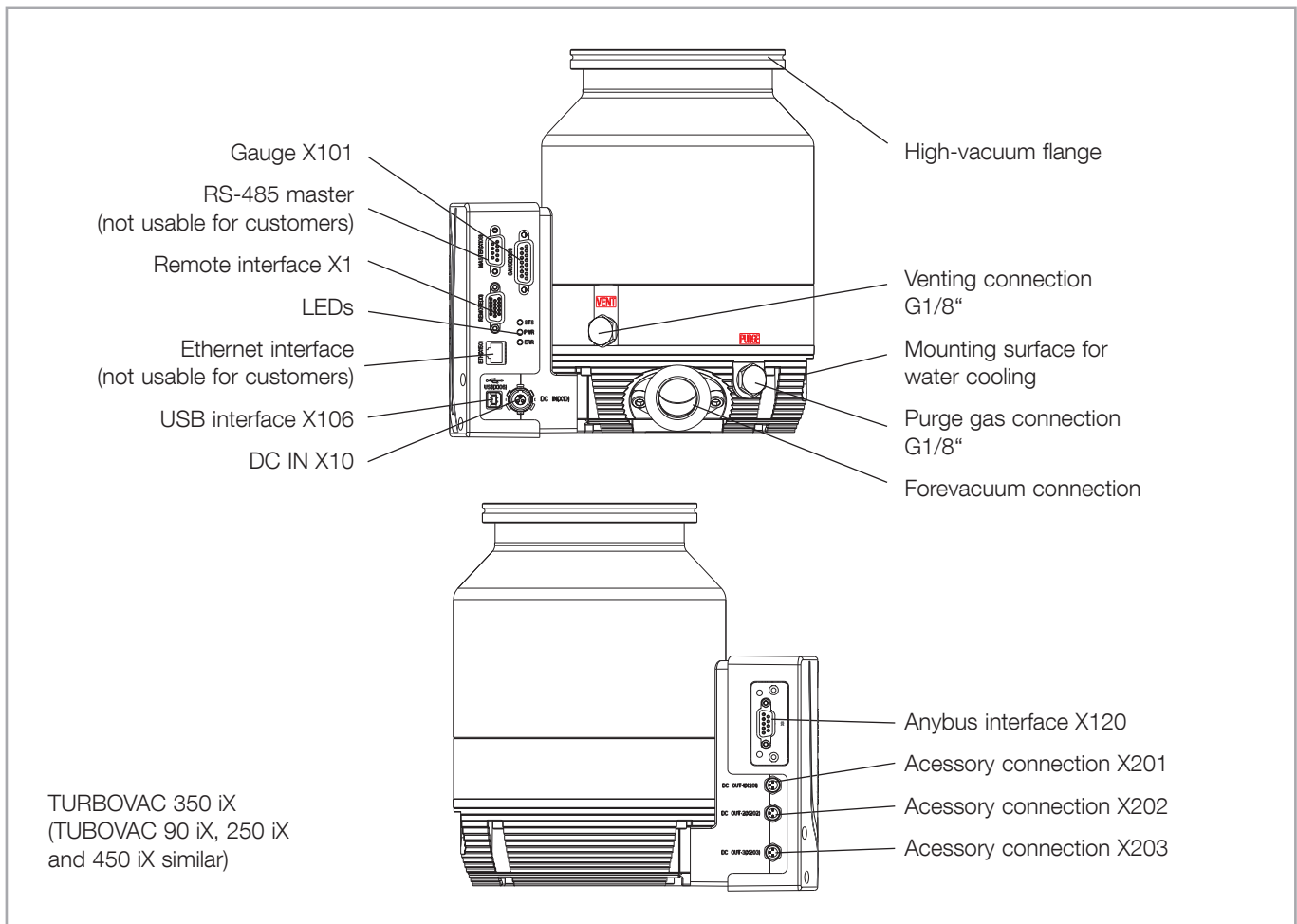

Fig. 3.4 Connections

3.4 Attach the pump to the vacuum chamber

Never touch the rotor. Touching the rotor may cause injury and damage the rotor bearing.

The high vacuum flange must be solidly mounted to the vacuum chamber. Observe Safety Information 0.1.6.

Remove the transport seal from the intake flange and remove the desiccant. Pay attention to maximum cleanliness when connecting.

In the case of a sudden rotor vane rupture or rotor-stator contact which may occur in practice (caused, for example, by solid objects from the process chamber entering the pump through the high vacuum flange), the following torques need to be absorbed by the system:

TURBOVAC 90 i(X)	max. 250 Nm
TURBOVAC 250 i(X)	max. 850 Nm
TURBOVAC (T) 350 i(X), (T) 450 i(X)	max.1000 Nm

In most applications the pump is flanged to the high vacuum flange at the apparatus. The pump can be mounted and operated in any desired attitude.

When using flange connecting elements in accordance with DIN 28404, ISO 1609 (ISO-K flange connection) or ISO 3669 (CF flange connection), which fit positively to the pump flange, check the maximum load capacity of the connecting element. Not all flange components can withstand the forces that occur in a crash.

If the strength of the component is not sufficient, there is the possibility of providing an additional safeguard via the three threaded holes in the base of the pump.

The flange material to which the pump is bolted, must have at operating temperature a minimum strength specification of 150 N/mm².

Operation with vibration absorber

To decouple extremely sensitive equipment and to prevent transfer of external vibrations to the pump a special resonance damper is available for mounting at the high vacuum flange.

In this case mount the turbomolecular pump separately. A vibration absorber cannot reliably sustain the high deceleration torque in case of a rotor seizure.

If additional mounting is not possible, then the pump must be protected by a suitable shield during operation.

NOTICE



WARNING



Torque when the rotor seizes

Installation

On the cooling surface it is possible to connect a vibration sensor: thread M6, 10 mm deep.

If several turbomolecular pumps are installed to the vacuum chamber of the same system, there is the risk of interference (vibration interference between the pumps). If such a risk exists please contact Leybold Application Support.

The standard mounting arrangement for the pump is adequate to ensure earthquake protection. If required mount the system to the floor or the walls.

Install a splinter guard or an inlet screen

To protect the TMP against foreign material from the vacuum vessel we recommend to mount a centering ring with a fine or coarse inlet screen at the high vacuum flange, though this will reduce the pumping speed at the chamber flange.

Reduction of the pumping speed in %	H ₂	He	N ₂	Ar
Fine inlet screen DN 63		on request		
Coarse inlet screen DN 63		on request		
Fine inlet screen DN 100	5	7	24	24
Coarse inlet screen DN 100	2	2	10	8
Fine inlet screen DN 160	6	9	20	23
Coarse inlet screen DN 160	1	2	6	7

Damages caused during operation without the inlet screen are excluded from warranty.

Flange mounting for ISO-K flanges

When flanging on the high vacuum connecting flange, place the O-ring on the centering ring. The O-ring must remain in place smooth and untwisted. Thereafter put the outer ring (support ring) in place.

Mount the turbomolecular pump according to Fig. 3.5 and 3.6 and tighten the bolts crosswise step-by-step.

When using an ultra sealing ring, always use an outer support ring. The information on the number of bolts and clamps also applies to the ultra sealing rings.

Required for the installation:

- mounting kit (accessories)
- coarse or fine inlet screens (accessories, optional)

NOTICE



The contact surfaces of pump housing, vacuum system and centering ring must be free of grease and dry so as to ensure adequate strength in case the rotor should seize.

ISO-K flange at ISO-K flange

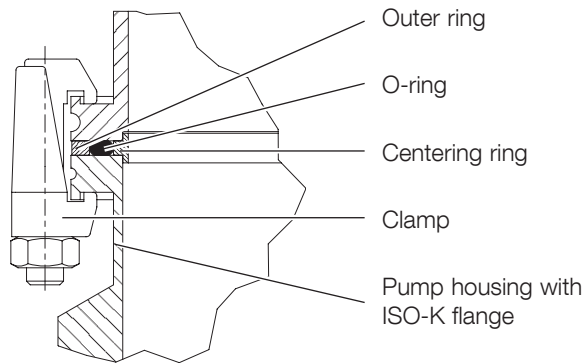

Flange	DN 63 ISO-K	DN 100 ISO-K	DN 160 ISO-K
Number of clamps	4 x M10	6 x M10	6 x M10
Minimum clamp strength, yield strength	> 450 N/mm ²		
Fastening torque	20 ⁺³ ₀ Nm		

The fastening torque levels apply to lubricated threads.

ISO-K flange at ISO-F flange with collar flange

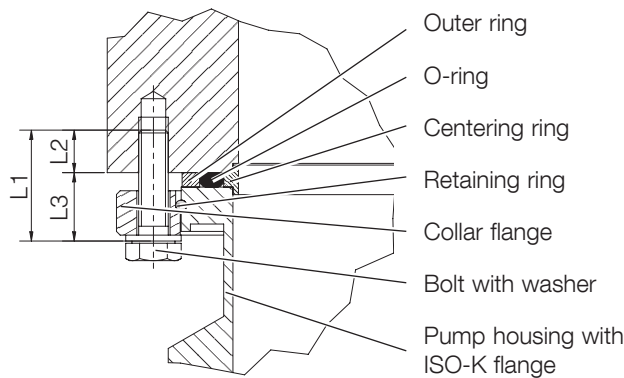

Flange	DN 63 ISO-K	DN 100 ISO-K	DN 160 ISO-K
Number of bolts	4 x M8	8 x M8	8 x M10
Minimum bolt strength, yield strength	> 450 N/mm ²	> 600 N/mm ²	> 600 N/mm ²
Minimum screw in depth L2 for steel	12 mm	12 mm	13 mm
for aluminium	16 mm	12 mm	18 mm
L3	18.5 mm	18.5 mm	23 mm
Recommended bolts – ISO 4014 for steel flanges	M8x30	M8x30	M10x40
for aluminium flanges	M8x35	M8x30	M10x45
Bolt quality stainless steel bolts	8.8 or A2(A4)-70	8.8 or A2(A4)-80	8.8 or A2(A4)-80
Fastening torque	15 ⁺² ₀ Nm	20 ⁺³ ₀ Nm	35 ⁺⁵ ₀ Nm

Fig. 3.5 Mounting high vacuum flange ISO-K

Installation

ISO-K flange at ISO-F flange with claws

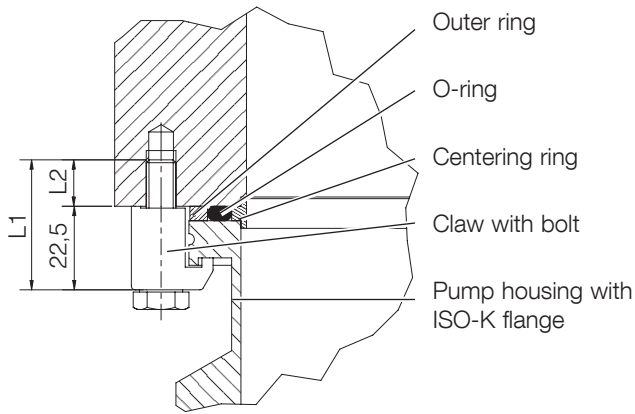

The fastening torque levels apply to lubricated threads.

Flange	DN 63 ISO-K	DN 100 ISO-K	DN 160 ISO-K
Number of clamps	4 x M8	8 x M8	8 x M10
Minimum bolt strength, yield strength	> 450 N/mm ²	> 600 N/mm ²	> 600 N/mm ²
Minimum screw in depth L2 for steel for aluminium	12 mm 16 mm	12 mm 12 mm	13 mm 18 mm
Recommended bolts – ISO 4014 for steel flanges for aluminium flanges	M8x35 M8x40	M8x35 M8x35	M10x35 M10x40
Bolt quality stainless steel bolts	8.8 or A2(A4)-70	8.8 or A2(A4)-80	8.8 or A2(A4)-80
Fastening torque	15 ⁺² ₀ Nm	20 ⁺³ ₀ Nm	35 ⁺⁵ ₀ Nm

Fig. 3.6 Mounting high vacuum flange ISO-K

CF flange connection with clearance hole

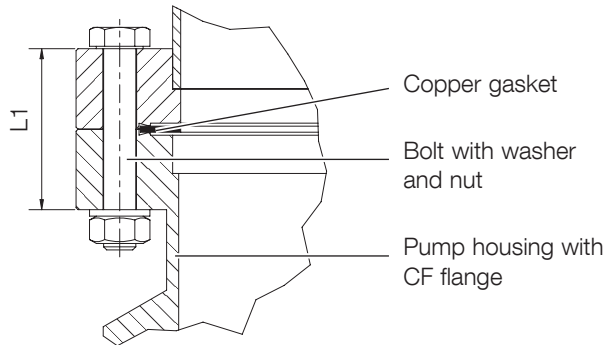

Flange	DN 63 CF	DN 100 CF	DN 160 CF
Number of bolts	8 x M8	16 x M8	20 x M8
Minimum bolt strength, yield strength		> 450 N/mm ²	
Recommended bolts – ISO 4014 L1 =	M8x45 35	M8x50 40	M8x55 44
Bolt quality stainless steel bolts		8.8 or A2(A4)-70	
Fastening torque		15 ⁺² ₀ Nm	

The fastening torque levels apply to lubricated threads.

CF flange connection with blind hole thread

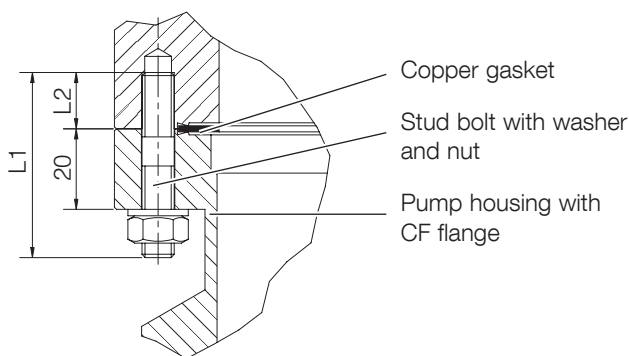

Flange	DN 63 CF	DN 100 CF	DN 160 CF
Number of bolts	8 x M8	16 x M8	20 x M8
Minimum bolt strength, yield strength		> 450 N/mm ²	
Minimum screw-in depth for steel	12 mm	12 mm ≤ L2 < 16 mm	
Recommended bolts for steel flanges – DIN 835 L1 =		M8x30 45	
Bolt quality stainless steel bolts		8.8 or A2(A4)-70	
Fastening torque		15 ⁺² ₀ Nm	

Fig. 3.7 Mounting the CF high vacuum flange

Installation

Flange mounting for CF flanges

Before fitting, check to ensure that the sealing edge is undamaged. Do not touch the copper gasket and the sealing edge with your bare hands.

NOTICE



The contact surfaces of pump housing, vacuum system and centering ring must be free of grease and dry so as to ensure adequate strength in case the rotor should seize.

Mount the turbomolecular pump according to Fig 3.7 and tighten the bolts step-by-step.

When the pump shall be baked out, the threads of the bolts should have been lubricated with a high temperature lubricant.

Owing to the deformation of the copper gasket, the fastening torque of all bolts must be checked once more after having completed the installation work.

Required for the installation:

- mounting kit (accessories)
- coarse or fine inlet screens (accessories, optional)

CAUTION



During operation the pump can get so hot that there is the risk of suffering burns (up to approximately 65 °C). Protect the hot parts against being touched.

3.5 Forevacuum connection

The forevacuum flange may be detached, turned by 180°, and refit, cf. the dimensional drawing of Fig. 1.22. Tightening torque for the screws is:

TURBOVAC 90 i(X), 250 i(X)	$3 \pm 0,5 \text{ Nm}$
TURBOVAC (T) 350 i(X), (T) 450 i(X)	5^{+2}_0 Nm

Connect the clean forevacuum line with the small flange connectors or the hose couplings, and take care not to constrict the forevacuum flange's diameter.

Ensure that the pump is sufficiently isolated against vibrations generated by the forevacuum pump.

No forces from the piping system may be allowed to affect the turbomolecular pump. Support the piping correspondingly or decouple through flexible joints.

DANGER



The forevacuum line must be tight. Hazardous gases can escape at leaks or the gases being pumped can react with air or humidity. Observe Safety Information 0.4.5.

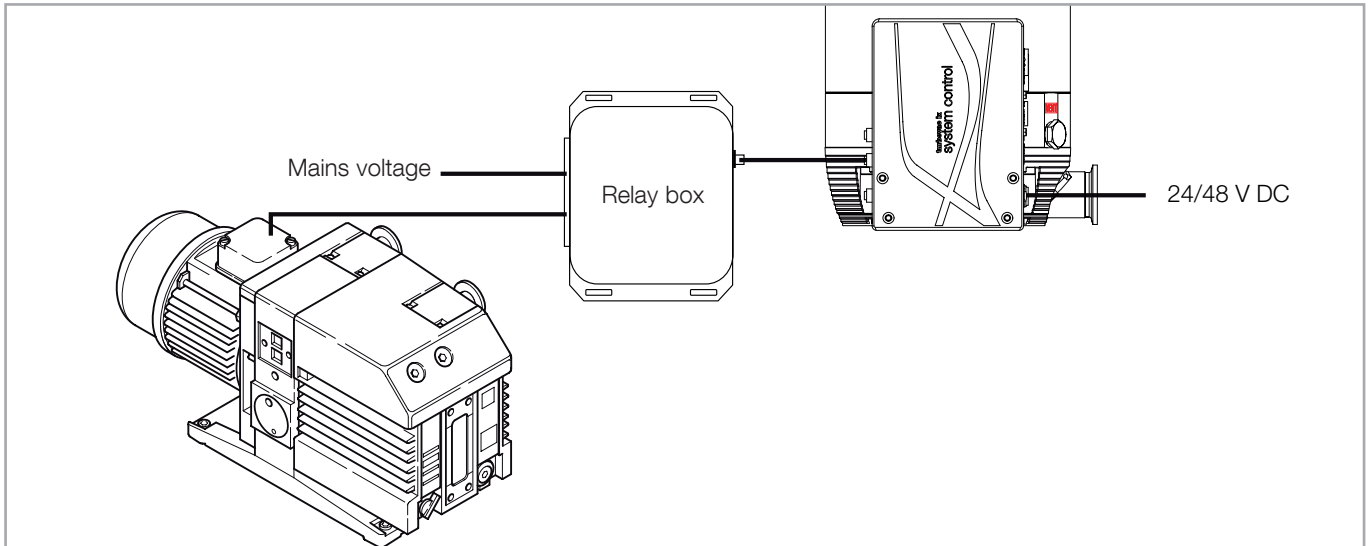

Fig. 3.8 Connecting the forevacuum pump via the relay box

Only for TURBOVAC i

The forevacuum pump can be energised at the accessories connection of the TURBOVAC via the relay box.

Only for TURBOVAC iX

A forevacuum pump may be electrically connected through the relay box to accessory connection X202 on the TURBOVAC iX.

The relay box switches the forevacuum pump on when a start command is present for the turbomolecular pump, and the relay box switches the forevacuum pump off when the start command is revoked.

Through parameter 643[1] the switch-on delay time and through parameter 644[1] a shutdown delay time in seconds can be set up (the default for both parameters is 0).

Installation

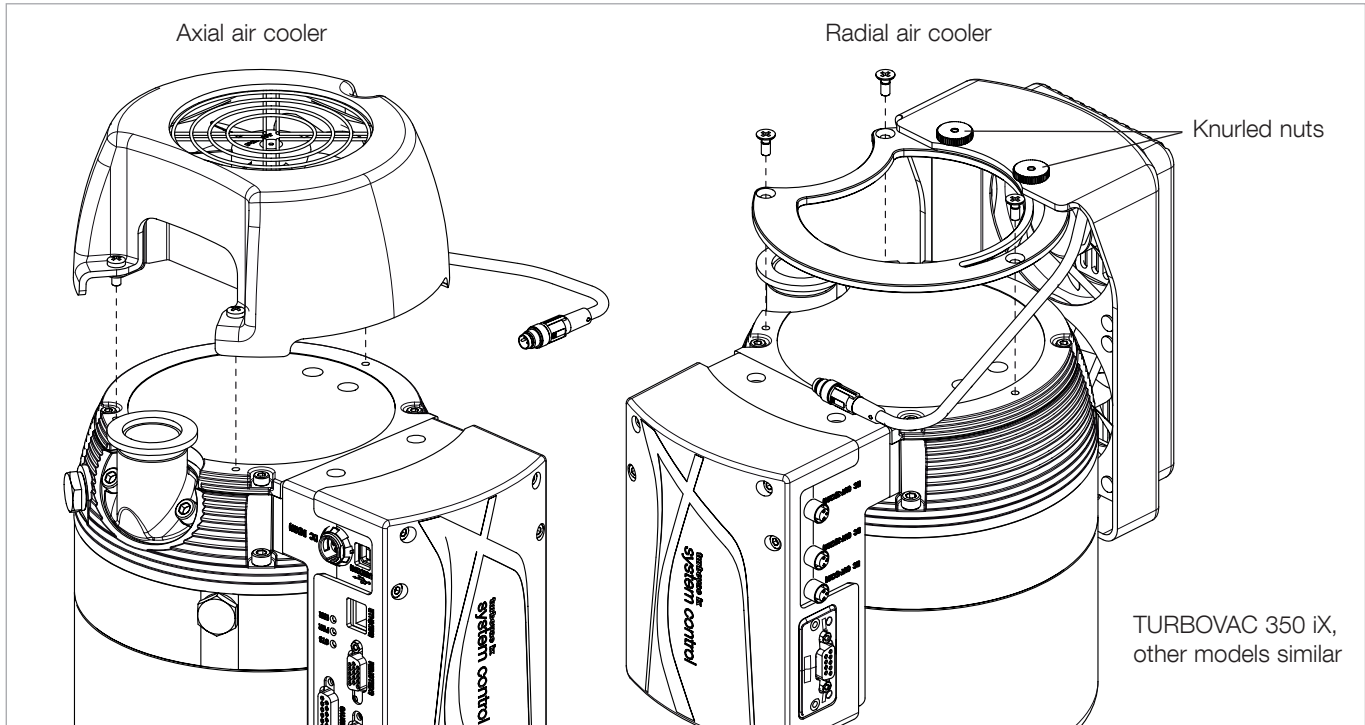

Fig. 3.9 Mounting air coolers

3.6 Connect the cooling

Cooling of the pump depends on the required pumping power and the ambient temperature. When the pump is insufficiently cooled it will shut down.

High gas throughputs, cyclic operation or high ambient temperatures will necessitate air or water cooling, refer to the operations diagram for the TURBOVAC 90 i (Fig. 1.4) or Fig. 3.13 for the TURBOVAC 350/450 i(X).

3.6.1 Air cooling

When installing air cooled pumps within a system ensure that sufficient quantities of fresh air are freely available. The air cooling facility is powered via the pump.

Use the 3 bolts which are included in the delivery to attach the air cooling unit at the bores provided on TURBOVAC, see also the resp. dimensional drawings. Plug in the control cable of the air cooler into the accessories connection (X201 for the TURBOVAC iX) and screw tightly. The accessory connection is so pre-configured that the air cooler will always be running when the pump is running. To change this setting, refer to the interface Operating Instructions.

The radial air cooler may be adjusted and turned after loosening the 2 knurled nuts, refer to the air cooler Operating Instructions.

3.6.2 Water cooling

Attach the cooling water block to the TURBOVAC with 2 M6 screws, tightening torque is 8_0^{+2} Nm . Depending on the requirements the supply or the drainage may be arranged radially or axially, cf. the dimensional drawings. Connect the cooling water hoses.

The hose connections may be unscrewed and removed, to make use of the integrated G 1/8"-threads.

Adjust the cooling water temperature so that the formation of condensate is avoided. With pump downtimes the cooling water has to be turned off.

When switching the cooling water supply on and off by means of an electrically actuated valve, connect the valve so that it will be switched on and off together with the pump.

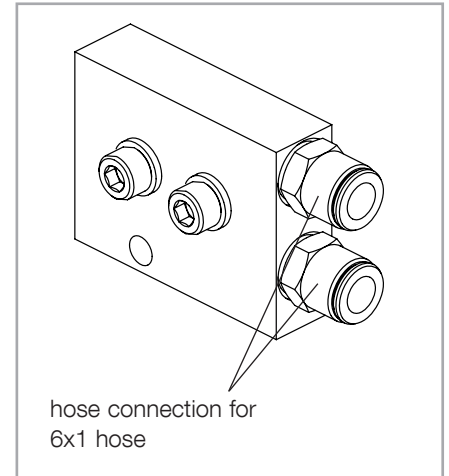

Fig. 3.10 Cooling water block

3.6.3 Water Quality

In order to ensure long trouble-free operation the cooling water must not contain any oils, greases and suspended solids. Moreover, we recommend compliance with the following limit values:

Appearance	Clear, free of oils and greases
Suspended matter	< 250 mg/l
Particle size	< 150 µm
Electrical conductivity	< 700 µS/cm
pH value	7.0 to 9.0
Total hardness (total alkaline earths)	< 8 °dH
Aggressive carbon dioxide	None, not detectable
Chloride	< 100 mg/l
Sulphates	< 150 mg/l
Nitrate	≤ 50 mg/l
Iron	< 0.2 mg/l
Manganese	< 0.1 mg/l
Ammonium	< 1.0 mg/l
Free chlorine	< 0.2 mg/l

8 °dH (degrees German hardness) = 1.4mmol/l
 = 10 °e (degrees English hardness)
 = 14 °f (degrees French hardness)

If there is the danger of frost, you may use a water glycol mixture of up to 30 %.

DS water (softened or fully desalinated water) can be used for cooling the pump, if the pH value corresponds to the range indicated above.

Installation

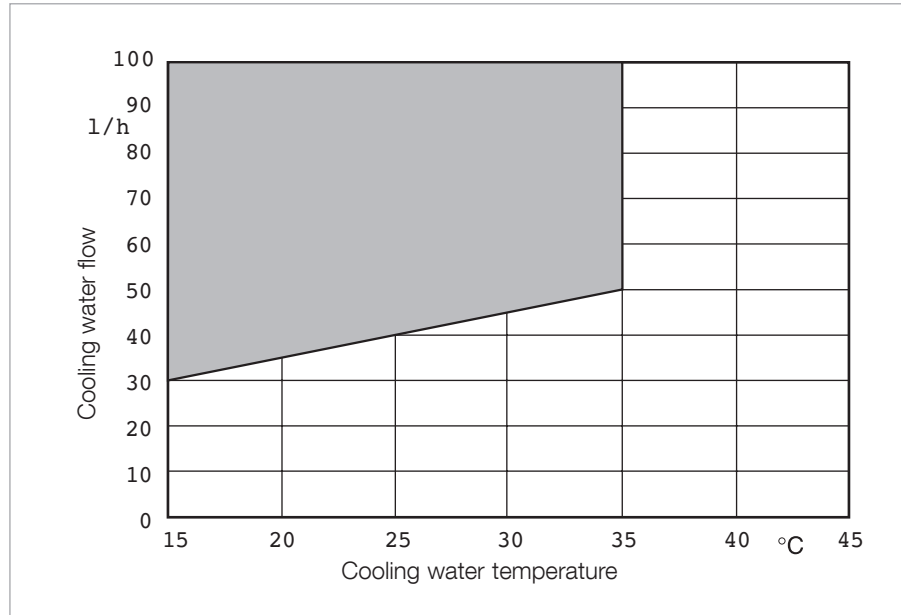

Fig. 3.11 Cooling water requirements



Abb. 3.12 Dewpoint diagram

Cooling conditions for pumps with an ISO-K flange and aluminium housing

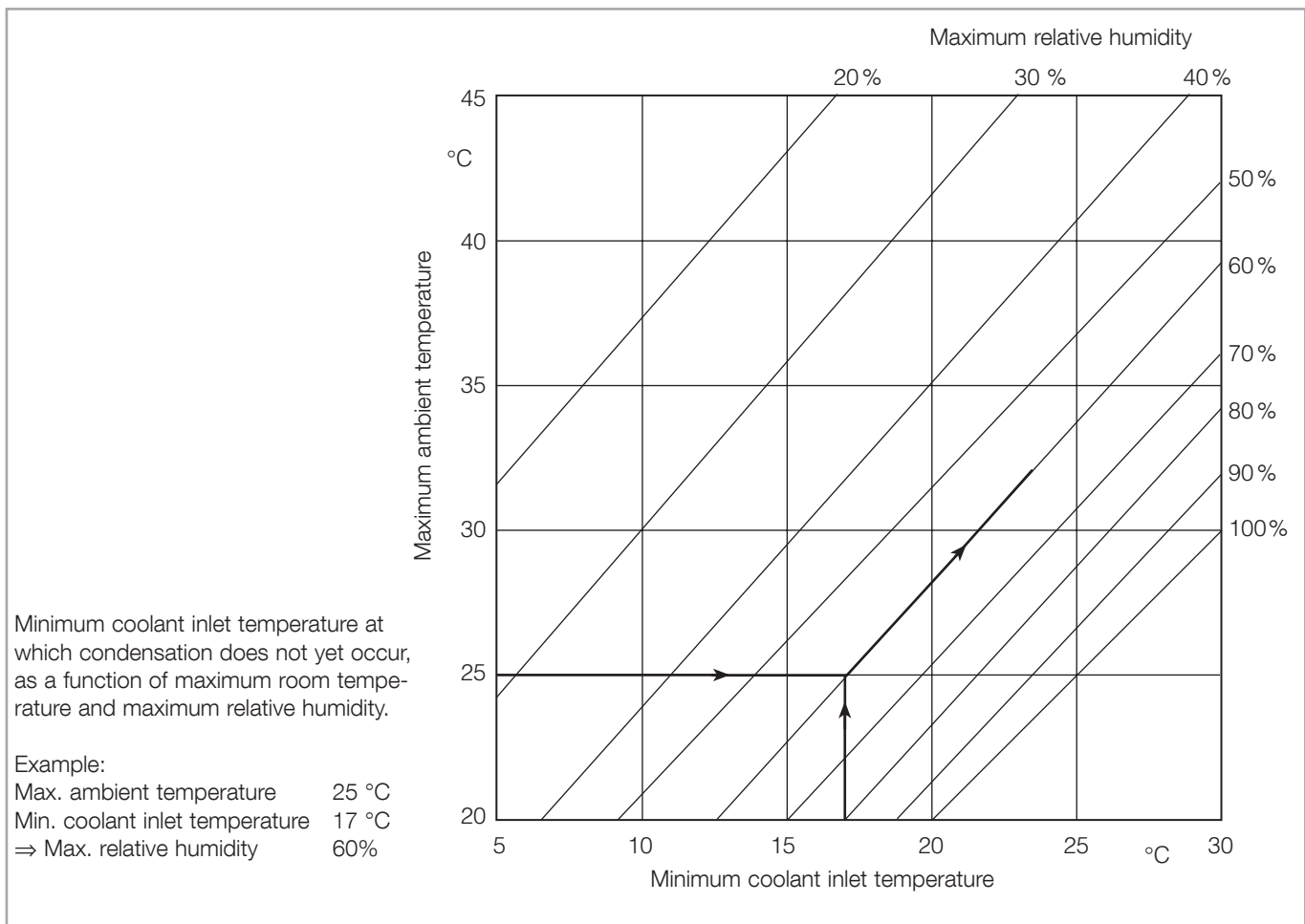
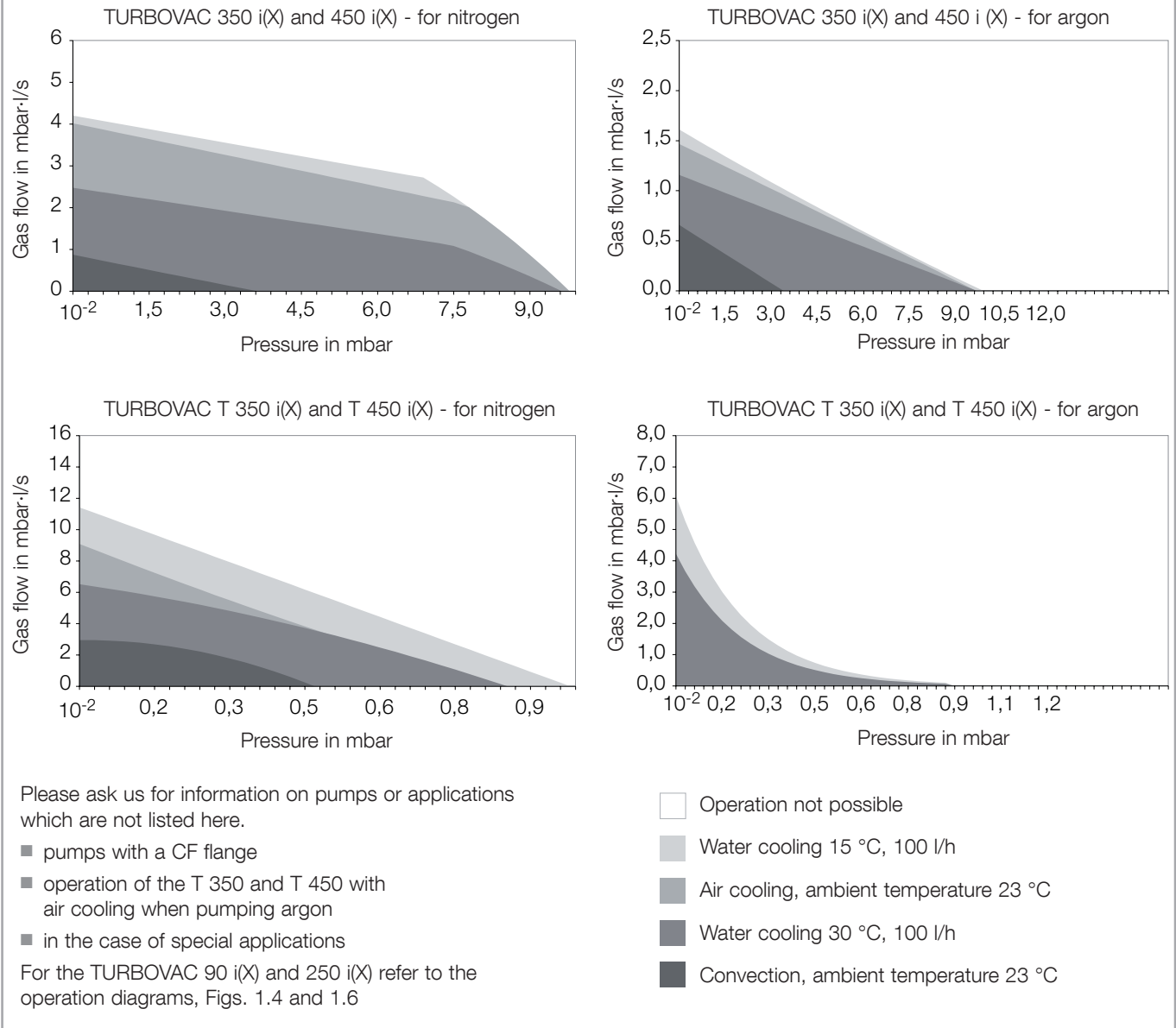

Fig. 3.13 Cooling conditions

Installation

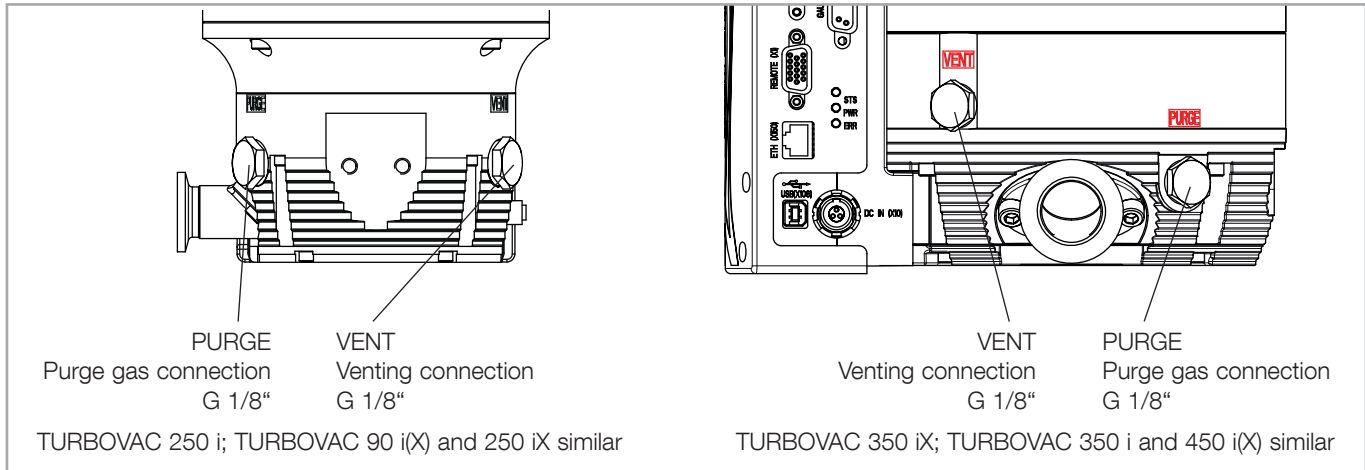

Fig. 3.14 Venting and purge gas connections

3.7 Connect a power failure venting valve or a venting valve

The power failure venting valve (normally open) or venting valve (normally closed) vents the pump and the forevacuum line when the pump is switched off and thus keeps oil vapor from diffusing back from the forevacuum line. A choke nozzle in the vent port ensures that the pump is not vented too fast.

The max. permissible pressure in the pump must not exceed 1.4 bar (abs.).

Unscrew and remove the locking screw and the gasket from the venting connection of the TURBOVAC.

Screw in the venting valve and the gasket into the venting connection.

If applicable connect the venting gas supply at the valve's inlet (G1/8").

WARNING



The pressure in the pump must not exceed 1400 mbar (0.4 bar overpressure). Observe Safety Information 0.1.2 to 0.1.5.

NOTICE



Connect a purge gas or venting valve to the correct flange. Confusing the venting and purge gas flange can cause shock venting of the pump.

Only for TURBOVAC i

Plug in the corresponding control cable into the accessories connection.

For the electronic drive unit change the venting valve settings to venting operation (via the interfaces).

Only for TURBOVAC iX

Plug in the corresponding control cable into the accessories connection X203. Accessory connection X203 is so pre-configured that the venting valve opens when the start command is revoked and the frequency drops below 999 Hz. At 5 Hz this valve is closed again. This is no power failure venting! The limits can be changed through parameter 28[2] (upper switching threshold) and parameter 647[2] (lower switching threshold). For this refer to the

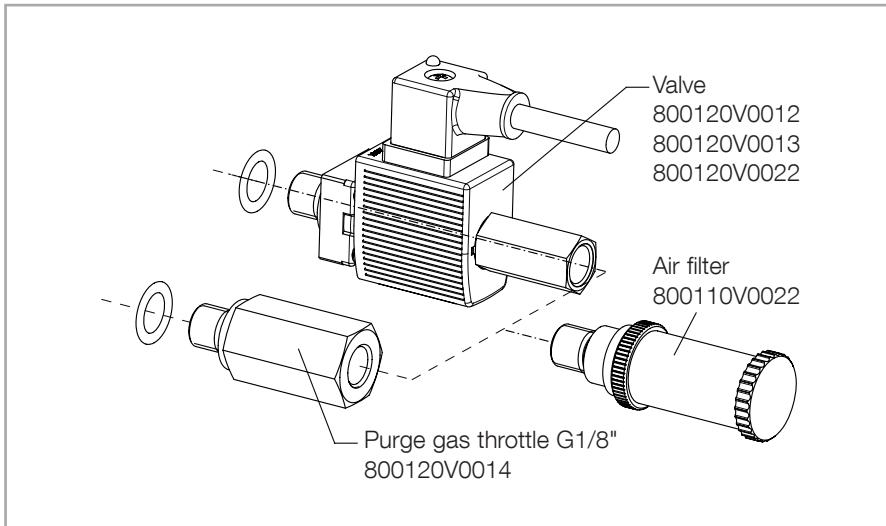

Fig. 3.15 Fitting valve

interface Operating Instructions.

Either connect a power failure venting valve electrically separately or connect it to X201, X202 or X203 and thereafter change the function for the accessory connection. For this refer to the interface Operating Instructions.

3.8 Connect purge gas

When having to decide which gases need or not need to be pumped with purge gas we are available to provide assistance.

Refer to Section 4.1 for suited gases.

Consider the additional purge gas flow when selecting a suitable backing pump.

We recommend a purge gas flow of 0.4 mbar-l/s (24 sccm) with Nitrogen.

The pressure in the pump must not exceed 1400 mbar (0.4 bar overpressure). Observe Safety Information 0.1.2 to 0.1.5.

WARNING



The purge gas is fed either through an activated valve or a manually operated throttle.

Purge gas connection with purge gas valve

Unscrew and remove the locking screw and the gasket from the purge gas connection of the TURBOVAC.

Screw in the purge gas valve and the gasket into the thread.

Connect the purge gas supply at the valve's inlet (G1/8").

Either connect the purge gas valve electrically separately or connect it to an accessory connection and thereafter change the function for the accessory connection. For this refer to the interface Operating Instructions.

Installation

Purge gas connection with purge gas throttle

Unscrew and remove the locking screw and the gasket from the purge gas connection of the pump.

Then screw in the throttle and the gasket into the thread.

3.9 Connect a flange heater

Only for TURBOVACs with CF flange

If pressures in the range of 10^{-8} mbar or below are to be developed, the vacuum chamber and the components installed therein will have to be baked out. In addition, the TURBOVAC can be baked out using the flange heater provided for this purpose.

With the aid of the relay box the heating jacket can be driven directly via the turbopump. For this connect the heating jacket to the relay box and insert the connection cable of the relay box at the accessory connection (X201 for the TURBOVAC iX) and screw it down.

The accessory connection has been so pre-configured that the heating jacket will heat as long as the turbomolecular pump is running. To change this setting, refer to the interface Operating Instructions.

Alternatively the heating jacket may be connected through the corresponding mains power cable to the power supply.

Information on baking out is also given in Section 4.6.

3.10 Connect a vacuum gauge head (only for TURBOVAC iX)

One of the listed vacuum gauge heads may be connected to connection X101.

Connect the vacuum gauge head only after having switched off the pump first.

Vacuum gauge head	Connection cable	Pressure range
TTR 101, TTR 101 S2, TTR 101 N, TTR 101 N(S2)	Type F	5×10^{-4} ...1500 mbar
ITR 200 S, ITR 200 SL, ITR 200 SP, ITR 200 SD	Type C	5×10^{-10} ...1000 mbar
PTR 225, PTR 225 S, PTR 237, PTR 225 N, PTR 225 N(S), PTR 237 N	Type F	1×10^{-9} ... 1×10^{-2} mbar
CTR 100/101, CTR 100 N, CTR 101 N	Type C	1×10^{-1} ...1000 torr to 1×10^{-5} ...0,1 torr
TTR 91, TTR 91 S, TTR 96 S, TTR 91 N, TTR 91 N(S), TTR 96 N(S)	Type F	5×10^{-4} ...1000 mbar
PTR 90, PTR 90 N	Type F	5×10^{-9} ...1000 mbar
ITR 90, ITR 90 P	Type C	5×10^{-10} ...1000 mbar

The type of connected vacuum gauge head is detected automatically.

The measured value can be read out in millibar, Torr and Pascal through parameter as real value.

P616: measured value in millibar

P617: measured value in Torr

P618: measured value in Pascal

Further parameters (like filter time, CTR vacuum gauge head subtype, gas type correction factor etc., for example) may be set up for the respective vacuum gauge head.

For this refer to the interface Operating Instructions.

Installation

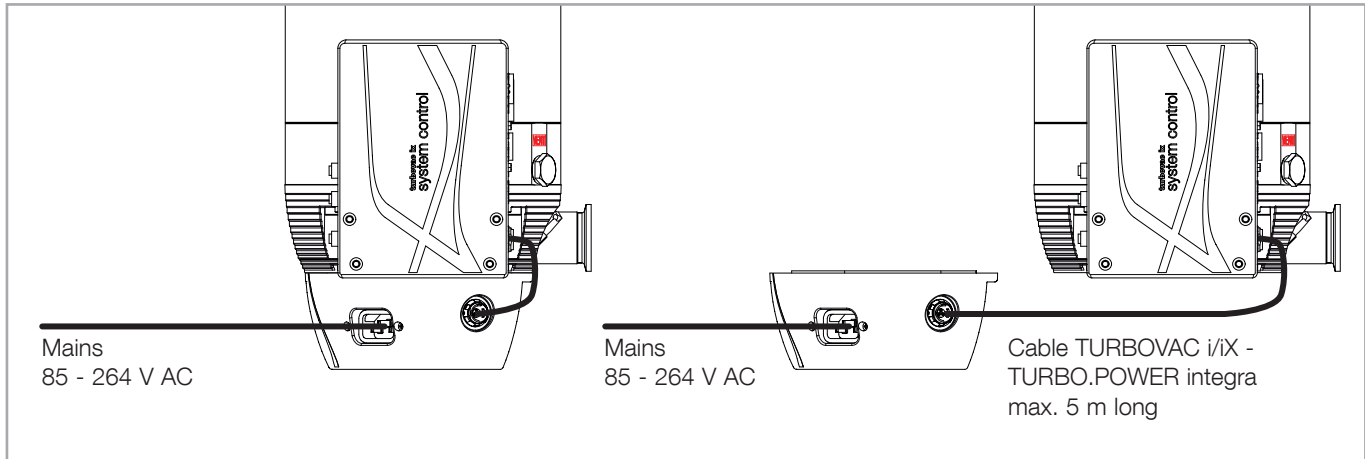

Fig. 3.16 TURBOVAC iX with power supply

3.11 Electrical connection

DANGER



Observe Safety Information 0.2

Unplug any connectors only when the mains voltage is switched off **and** the pump does no longer turn.

NOTICE



Ensure correct polarity

Pin 1 24/48 V

Pin 2 GND

Pin 3 0 V

The pump can be operated with 24 V or 48 V DC power supply. Take note of the performance data specified in Section 1.3.1.

When pulling the DC IN connector first retract the retaining sleeve

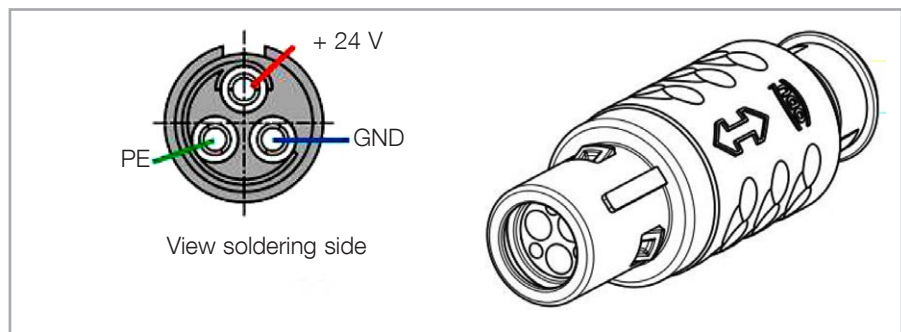

Fig. 3.17 Power supply connector DC IN (X10)

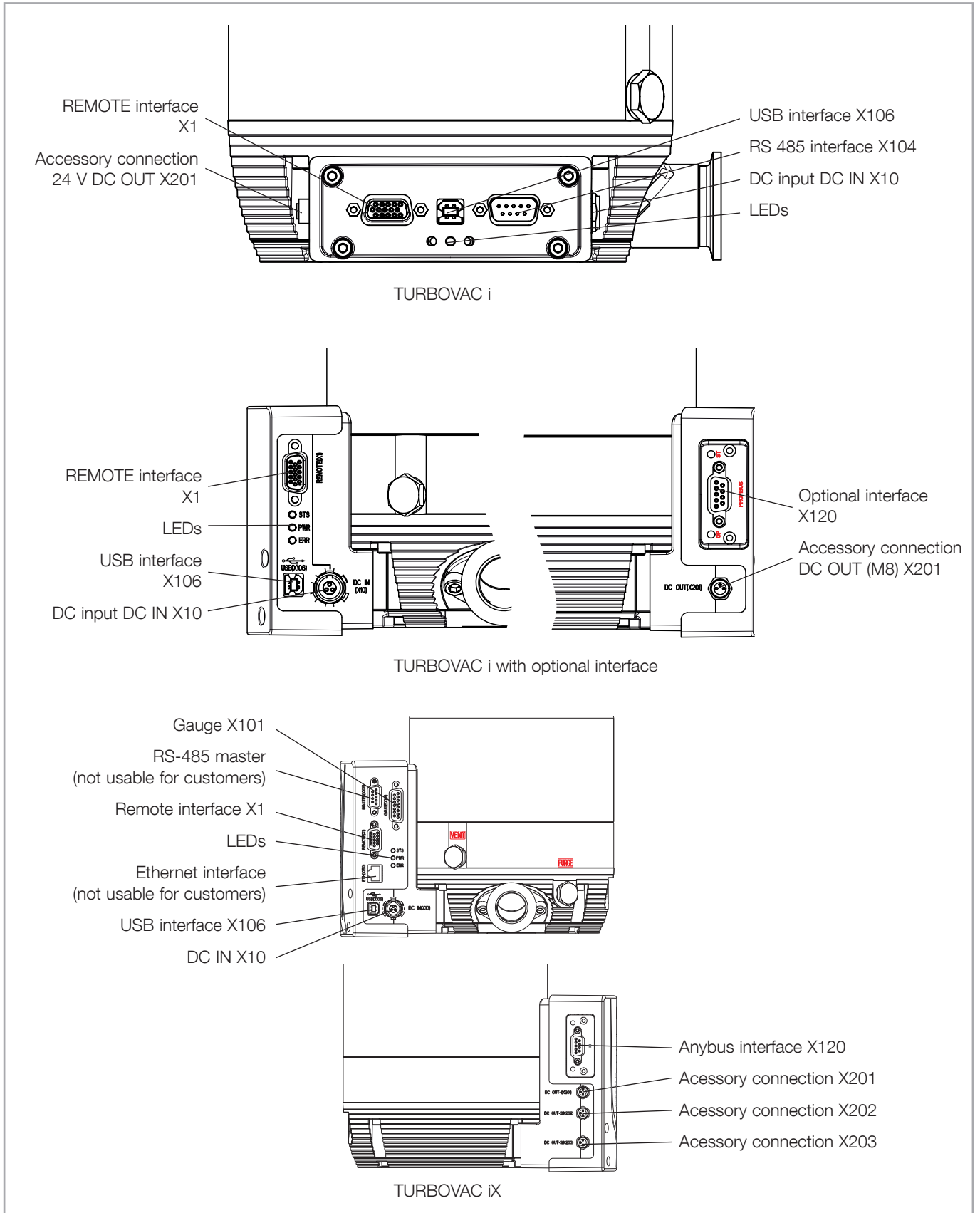

Fig. 3.18 Interfaces

Installation



 STS  PWR  ERR	green LED STATUS	
	off:	Pump at standstill (< 3 Hz)
	flashes slowly 1/s:	Start command is present (about 10 s after start)
	flashes fast 3/s:	Running up
	flashes slowly 0.5/s:	Running down
	on:	Normal operation
	yellow LED POWER	
	off:	No supply voltage
	flashes 1/s:	Supply voltage too low or too high
	flashes 3/s:	Running down and pump speed < 100 Hz
	on:	Supply voltage is present
	red LED ERROR	
	off:	No error, no warning
flashes:	Warning is present, pump can be operated possibly with some restrictions	
on:	Fault is present, pump stopped or can not be operated	
LED running light (green-yellow-red)		
Pump is in a state in which it cannot be controlled		
Possible reasons:		
<ul style="list-style-type: none">■ Initialisation shortly after switching on the supply voltage■ Memory procedure in progress (power supply must not be interrupted)■ Reset of factory setting is ongoing■ Firmware update is ongoing		
Valid from firmware parameter P2: R02.09.01		

Fig. 3.19 LEDs

The electronics are protected by an internal fuse. The fuse cannot be replaced by the customer.

The cable protection and voltage drop and the minimum supply voltage must be adhered to when wiring.

When operating more than one pump with a single power supply, it may be necessary to fuse each pump separately due to the line protection.

Emergency shut down: By shutting down the power supply voltage. Please note the information on shutting down and emergency shut down provided in Section 4.4.

REMOTE X1
15-pole Sub-D female
High Density

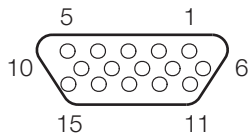

Maintain pin 6 Signal GND and pin 13 Analog GND separate so as to avoid equalisation currents.

Pin	Name	Description
1	Error relay	(com)
2	Error relay	(n.c.)
3	Normal operation relay	(n.o.)
4	Normal operation relay	(com)
5	Normal operation relay	(n.c.)
6	Signal GND	
7	High level output	24 V, 100 mA, Tolerance acc. to device supply voltage
8	Start input (High) Reset input (Low)	High > 10 V ± 0,5 V Low < 7.5 V ± 0,5 V
9	Error relay	(n.o.)
10	Standby input	High > 10 V ± 0.5 V Low < 7.5 V ± 0.5 V
11	Cooling/Venting valve input (Low)	High > 10 V ± 0.5 V Low < 7.5 V ± 0.5 V
12	Analog output (Default: Frequency)	0 ... 10 V, 2 mA
13	Analog GND	
14	Warning relay	(n.c.)
15	Warning relay	(com)
Shield	Connected with pump housing	

Start/Stop input

0V = STOP/Error reset
24 V = START

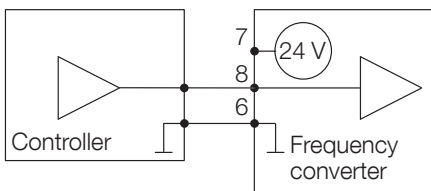

Pin 10

0 V = no Standby operation
24 V = Standby operation

Pin 11

0 V = no function
24 V = Cooling or valve is activated

Contact open = STOP/Error reset
Contact closed = START

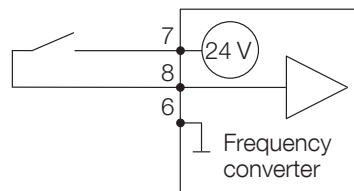

Pin 10

Contact open: no Standby operation
Contact closed: Standby operation

Pin 11

Contact open: no function
Contact closed: Cooling or valve is activated

Analog output

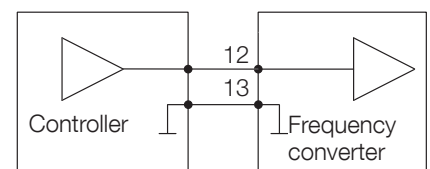

Relay

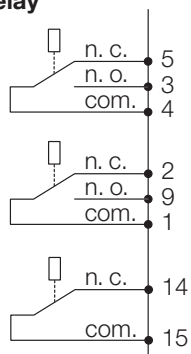

Normal operation relay

4 and 5 connected (normal position) Run-down, run-up, stop
4 and 3 connected Normal operation

Error relay

1 and 2 connected (normal position) No error
1 and 9 connected Error

Warning relay

14 and 15 connected (normal position) No warning
14 and 15 open Warning

Fig. 3.20 REMOTE interface X1

Installation

Relay status

Input data / status				Output data				Operating mode	
Start/stop signal	Pump rotating	Normal frequency \geq 90% of setpoint frequency	Error is present	Motor drive	Relay NORMAL OPERATION	Relay ERROR	LED STATUS (green)	LED ERROR (red)	Other modes are not possible; they indicate a failure affecting the frequency converter.
Stop	no	no	no	off	passive	passive	off	off	Pump not operating
Stop	yes	no	no	off	passive	passive	flashes	off	Pump is decelerating
Stop	yes	yes	no	off	passive	passive	flashes	off	Just after stop; pump was in the normal operating mode before that
Start	no	no	no	on	passive	passive	off	off	Just after start
Start	yes	no	no	on	passive	passive	flashes	off	Pump is accelerating
Start	yes	yes	no	on	active	passive	green	off	Pump is in the normal operating mode
Stop	no	no	yes	off	passive	active	off	red	Error is present; pump is at standstill
Stop	yes	no	yes	off	passive	active	flashes	red	Error is present; pump is decelerating
Stop	yes	yes	yes	off	passive	active	flashes	red	Error has just occurred
Start	no	no	yes	off	passive	active	off	red	Error is present; pump is at standstill
Start	yes	no	yes	off	passive	active	flashes	red	Error is present; pump is decelerating
Start	yes	yes	yes	off	passive	active	flashes	red	Error has just occurred

4 Operation

4.1 Media compatibility / purge gas

The TURBOVAC integra is suitable for pumping air and clean gases.

If reactive gases in low concentrations must be pumped operate the pump with purge gas.

We would be glad to consult with you as regards the media which can safely be handled with this unit.

Install a micropore filter when pumping media which contains dust.

Suited for venting or purging are all gases,

- which will not cause corrosion or pitting in aluminium and steel and
- which in connection with process deposits in the pump will not cause corrosion or sticking.

For venting and as the purge gas we recommend inert gases like nitrogen or argon. The temperature of these gases should be between 5 °C and 80 °C, max. relative humidity should not exceed 10 ppm.

The gas must be clean.

In individual cases and after consultation also dry, filtered, oil-free air or filtered ambient air may be used (filter mesh < 1µm).

Change the filters after some time, at least annually.

4.2 Interfaces

The TURBOVAC i(X) is always equipped with the following interfaces for customers:

- USB (COM port) (X106)
- REMOTE (X1)

Moreover, some models are equipped with an Anybus interface which in turn may be equipped with different interfaces like a RS 485, for example.

The control hierarchy is as follows: Anybus interface → USB → REMOTE (X1). See also parameter 179.

The frequency converter is configured through the parameters according to the parameter list. Pxxx denotes parameter value xxx.

The PC software LeyAssist allows convenient access by the user to the parameters of the frequency converter.

Operating Instructions 300450826 Serial Interfaces for TURBOVAC i/IX offer a detailed description of the interfaces RS 232, RS 485, Profibus and USB of the TURBOVAC.

Operation

Applications which can be implemented with the aid of the serial interface:

Application	Benefits to the customer	How to do it
Networking of several pumps and other equipment	Savings relating to the costs for signalling cables	With Field Bus systems
Automation	Savings related to repetitive manual work	For example by a control computer
Avoidance of warnings and warnings before overload operation and early detection of a failing pump	<ul style="list-style-type: none"> ■ Precise planning for maintenance ■ Improved reliability of sensitive production processes in a vacuum 	Monitoring of: <ul style="list-style-type: none"> ■ Motor current P5 ■ Motor temperature P7 ■ Frequency converter temperature P11
Standby operation	<ul style="list-style-type: none"> ■ Cutting process gas consumption ■ Cutting energy consumption 	Reducing the rotor's frequency through P24
Troubleshooting	Quick analysis of problems	Reading of error memories P171, P174 and P176: error code, speed, operating hours for error Read out warning messages through P227
Slow pressure control by changing the pumping speed	Dispensing with a flow controller	Changing the rotor frequency through parameter 24
Starting the pump with a delay if several consumers are connected to the same PSU	Cost savings through smaller power supply units if peak loads can be reduced	With P36, delay
Lowering the normal operation threshold	Normal operating mode is attained faster, processes can be started faster	Reduce frequency threshold through P25
Only for TURBOVAC iX: Switch the fan depending on temperature or frequency	Saving of electricity, reduce noise, optimise the pump temperature for the process	Configure accessory connection (X201, for example) correspondingly, for example, enter function code 30 in parameter 134[0] and set up the temperature limits in parameter 122[0] and 26[0].
Only for TURBOVAC iX: Individually adapt venting and purge gas (active venting, adaptation of the delay time etc.)	Save gas, process speed-up	Correspondingly configure the function code for an accessory connection (X203, for example)
Control cooling water flow	Avoid condensation during cooling water operation	Connect cooling water valve at accessory connection (X201, for example)
Enable generator operation (power backup mode)	The power produced by the pump when running in the generator mode may be used for other electrical consumers and the pump is also decelerated faster.	With P249 This function is only changed after de-energising the pump and then restarting it.
Only for TURBOVAC iX: Changing the function of the accessory outputs	Different applications for connected accessories	Configure the accessory connection, see interface Operating Instructions

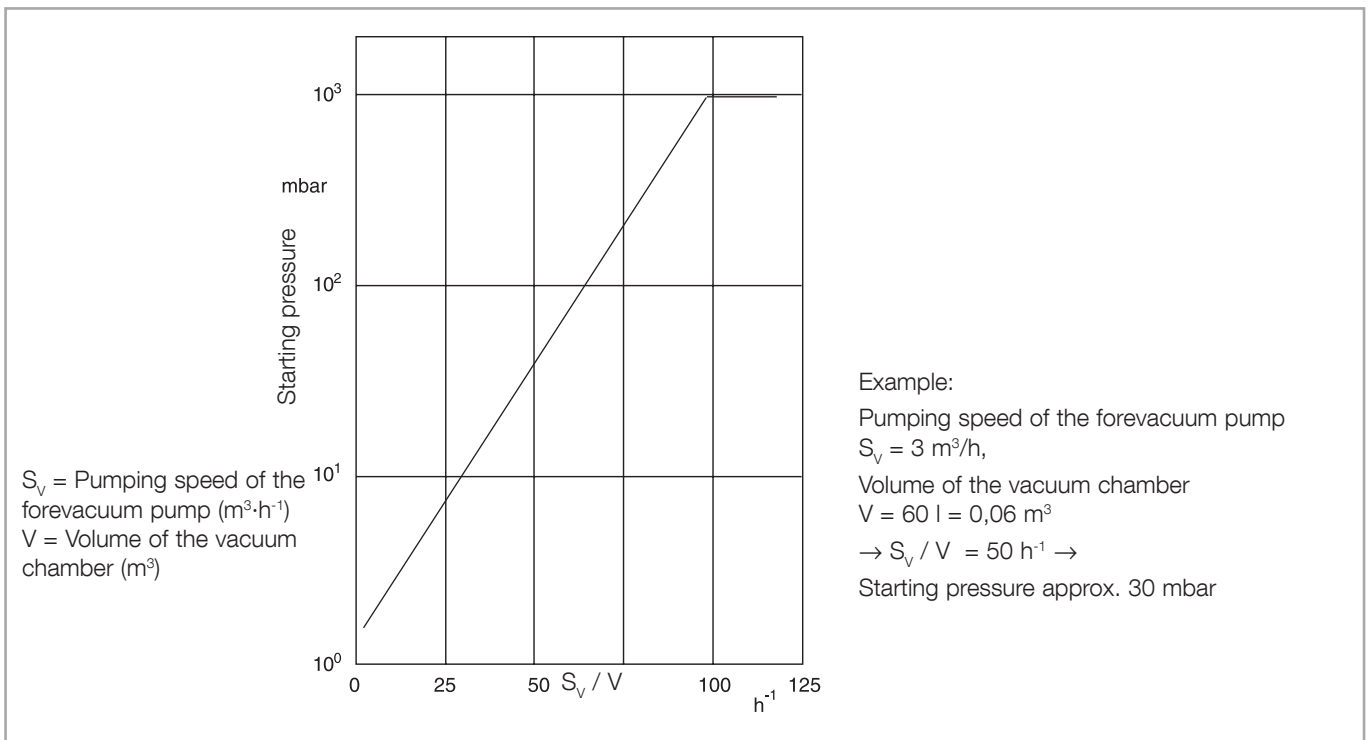

Fig. 4.1 Determining the starting pressure of a turbomolecular pump when evacuating large volumes

4.3 Switching on

Switch on the power supply. All LEDs come on one after the other (sequential light), drive electronics (and vacuum system controller) are running up (for approximately 35 seconds).

The maximum starting pressure for the turbomolecular pump can be read from the graph in Fig. 4.1.

Switch on the turbomolecular pump

- via pins 7 and 8 of the socket REMOTE (X1) (For example via a remote control or with the aid of the plug with integrated ON/OFF switch.
- by a start command via the interface.

The turbomolecular pump accelerates. The green LED flashes. When the pump reaches normal operation the green LED lights up permanently.

Avoid the influences of shock and vibration when the pump is running.

Exposure of the pump to accelerating forces must be avoided or reduced to such an extent that the rotor unit will not be excited by vibrations. In the case of critical applications you must consult our Applications Dept. first.

After a mains power failure the pump can run up automatically once more if a start command is present.

Starting pressure

NOTICE



4.4 Shutting down

Switch off the pump.

- via contacts 7 and 8 of the socket REMOTE (X1)
- apply a stop command via the interface
- for the power supply units offered or recommended by Leybold switch off the DC voltage.

Generator operation

After switching off, the green status LED will flash until the rotor of the turbomolecular pump is at standstill. This may take several minutes. With the DC power supply off, the turbomolecular pump will act as a generator supplying the frequency converter and the control unit with the connected devices with energy as indicated by the yellow power LED. When the generator mode is enabled, the turbomolecular pump supplies power back in to the DC power grid.

Switch off the forevacuum pump.

Venting

When using oil-sealed forevacuum pumps, vent the turbomolecular pump before it comes to a stop; refer to Section 4.5.

When using TRIVAC pumps the built-in anti-suckback valve will close automatically, shutting off the forevacuum line. In forevacuum pumps without a vacuum retention valve, close the valve in the forevacuum line.

When the system is not operating, ensure that neither ambient air nor cleaning media can enter the pump.

If a failure occurs the turbomolecular pump will be shut down automatically. The red LED at the frequency converter lights up.

Emergency shut down

In the case of an emergency shut down, the pump is switched off as described above. The rotor of the turbomolecular pump may be stopped faster by venting the pump.

Under vacuum conditions the pump may take up to one hour to run down, when venting to atmospheric pressure it may take up to one minute. During the time the pump is running down, the green LED will flash, indicating that the rotor has not yet arrived at standstill.

When shutting down by **switching off the power supply voltage**, there will be only enough power for the LEDs down to a speed of the pump of approximately 200 Hz. Thus the pump may still turn without a LED being on. For this reason, when switching off without venting, wait for approximately 15 minutes after the LEDs have turned off until the pump has arrived at standstill.

CAUTION



Unplug any connectors only when the mains voltage is switched off **and** the pump does no longer turn.

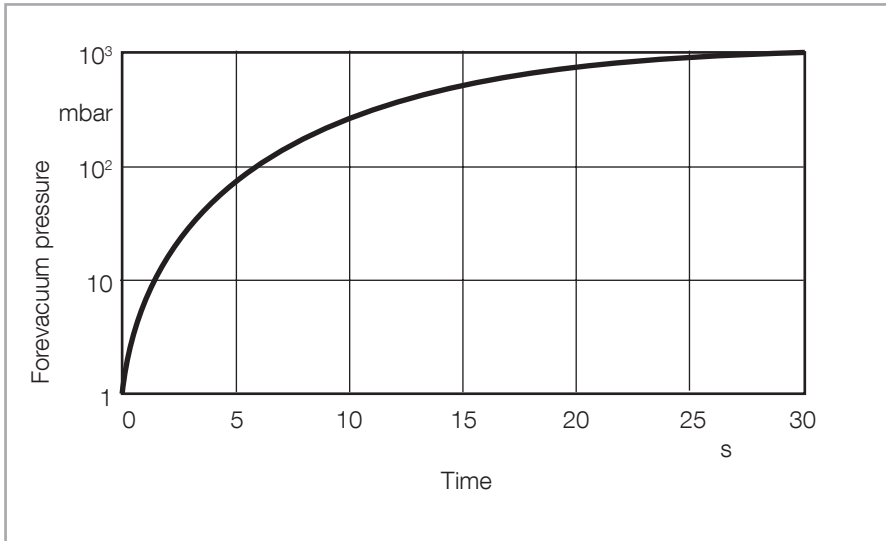

Fig. 4.2 Maximum rise in pressure

4.5 Venting

Refer to Section 4.1 for suited gases.

Venting Methods

There are three different methods of venting the turbomolecular pump.

The pump can be vented via the **venting connection (VENT)**, by means of a venting valve, a power failure venting valve, or a venting screw.

Cautious venting of the pump is possible from the **high vacuum side**, since here the bearing forces will be lowest. When doing so, no free jet of gas must be allowed to form on the rotor so as to avoid exposing the rotor to additional forces.

When venting the pump through its **foreline connection**, neither oil nor particles may be entrained in the gas flow from the forevacuum side into the pump.

Speed of the Pressure Rise

All turbomolecular pumps may be vented at full speed. However, the pressure must not increase faster than specified through the pressure rise curve, see Fig. 4.2..

The pump must be vented significantly slower when there is the risk of particles entering into the pump from the process. During venting, the flow must be of the laminar type in both the vacuum chamber and the turbomolecular pump.

The pump must not be vented to pressures above atmospheric pressure.

Speed

Pressure rise curve

Particles

4.6 Bakeout

Only for TURBOVACs with CF flange, see also Section 3.9.

If pressures in the range of 10^{-8} mbar or below are to be developed, the vacuum chamber and the components installed therein will have to be baked out. In addition, the TURBOVAC can be baked out using the flange heater provided for this purpose.

Protect the rotor against intensive, direct heat radiation. When baking out at the forevacuum side – at a sorption trap, for example – ensure that the components attached direct are not heated to more than 100 °C (212 °F).

Operate the pump with water cooling when baking out.

4.7 Removing the pump from the system

Shut down the pump and vent as described in Sections 4.4 and 4.5.

If the pump has previously handled hazardous gases, implement the proper precautionary measures before opening the intake or exhaust connection.

Observe Safety Information 0.4.6.

Disconnect the pump only when it has come to a full stop. The green LED must have gone out.

During run down the pump may still turn without a LED being on, observe the information on emergency shut down given in Section 4.4.

Then switch the mains power off and wait until the yellow power LED is off. Then only disconnect any cable connections.

The pumps may be contaminated with process gases. These gases may be toxic and hazardous to health. In addition, deposits with similarly dangerous properties may have formed. Many of these gases and deposits form acids when they come into contact with humid air. This will result in serious corrosion damage to the pump.

To avoid health hazards and corrosion damage when the pumps are detached from the system, fasten a container of desiccant under the transport cover of the high vacuum connection and then close the pump immediately at all flange connections. Store the pump, with a desiccant, in an airtight PE bag.

Corrosion damage due to faulty packing will nullify the guarantee.

Pack the pump so that it cannot be damaged during shipping and storage. Pay particular attention to protection for the flanges and the electrical plug.

Observe the instructions in Section 5.2 if you forward the pump to Leybold.

DANGER



Hazardous gases Deposits

Desiccant

Maintenance

5 Maintenance

Rotor exchange

We recommend an exchange of the rotor unit after 80,000 operating hours at the latest.

Such maintenance work can only be done by the Leybold Service. If required contact the Leybold service center nearest to your location. You can find the address on our internet page www.leybold.com.

At high pump loads - for example during cyclic operation, at high gas throughputs or at high ambient temperatures - the aforementioned maintenance work should be carried forward. Please consult Leybold for recommendations.

WARNING



Observe Safety information 0.1.7.

Bearing replacement

If required, the bearings may be changed on site by our after sales service or in the nearest Leybold Service Center. For such work please ask us for a quotation.

Purge gas filter

Depending on the degree of contamination of the purge gas used the filter will clog and will have to be exchanged (our experience indicates that this will become necessary after 1 to 6 months).

Adsorption trap

When an adsorption trap is used, regenerate or renew the adsorption agent regularly; refer to the operating instructions provided with the trap.

5.1 Cleaning

If required clean the turbomolecular pump of dust with a dry cloth.

Cleaning the frequency converter internally

The converter essentially requires no servicing since it contains no components which could be adjusted.

Depending on the installation particulars and the ambient conditions, the converter may collect grime (dust, moisture) on the inside. Such contamination can lead to malfunctions, overheating or short circuits and will have to be avoided to the maximum extent possible. The Leybold Service Department can clean the converter.

5.2 Leybold Service

Whenever you send us in equipment, indicate whether the equipment is contaminated or is free of substances which could pose a health hazard. If it is contaminated, specify exactly which substances are involved. You must use the form we have prepared for this purpose.

A copy of the form has been reproduced at the end of these Operating Instructions: "Declaration of Contamination for Compressors, Vacuum Pumps and Components". Another suitable form is available from www.leybold.com → Documents → Download Documents.

Attach the form to each pump.

This statement detailing the type of contamination is required to satisfy legal requirements and for the protection of our employees.

We must return to the sender any equipment which is not accompanied by a contamination statement.

Contamination

Form

Troubleshooting

CAUTION



6 Troubleshooting

When the connector cable is attached, the outputs at the frequency converter are not free of voltage.

Before you start searching for the source of the problem, you should carry out a few simple checks:

Are the connections in good working order?

- Mains connection,
- 24/48 V DC cable to the frequency converter.

Observe the polarity.

Is the forevacuum pressure sufficient?

After having removed the cause for the error reset the error message: By applying a STOP signal via the socket REMOTE (X1), or by a reset sequence via the serial interface or by switching the mains power off.

The error codes can only be read if a serial interface is present.

The following table has been provided as a guide when determining the causes of errors.

Malfunction	Possible cause	Remedy	Shut down
Yellow power LED is not on	No DC power DC power miswired Frequency converter defective	Check cables and power supply Ensure correct polarity of the DC cable. Have the pump repaired. The following may damage the freq. converter: - Disconnection of the DC cable while the pump was still rotating - Non-compliance with the note related to connecting several pump to a single power supply.	—
Red LED flashes	Warning message.	The pump can continue to run, as long as operation limits are only exceeded for a short time. In case of longer exceeding send pump and frequency converter to the Leybold service.	no
Turbomolecular pump does not start, ERROR LED does not light.	Interface protocol error No communication via the serial interface. REMOTE connector (X1) connected wrongly.	Use USS protocol. Connect bus as shown in the interface instructions Observe Fig. 3.20.	—
Turbomolecular pump produces loud running noises and vibrations.	Rotor out of balance Bearing defective	Balance the rotor Replace the bearing	no

Troubleshooting

Malfunction	Possible cause	Remedy	Shut down
Pump overload, pump cannot keep up its speed. When the speed drops below 900 Hz* the red LED flashes. When this continues for more than 12 min* the pump shuts down.	Forevacuum pressure too high.	Check the ultimate pressure of the backing pump and install a bigger backing pump if req.	yes
	Gas flow too high	Seal leak, check process	
	Fan defective	Replace fan	
	Water cooling switched off	Switch on water cooling	
Turbomolecular pump does not reach ultimate pressure.	Measurement instrument defective	Inspect the measurement sensor	no
	Measurement sensors soiled	Clean or replace the sensors	
	Leaks at the equipment, lines or the pump	Check for leaks	
	Pump soiled	Clean the pump	
	Forevacuum pump provides insufficient pumping speed or ultimate pressure which is too high.	Check the ultimate pressure of the forevacuum pump and install a higher-capacity vacuum pump if necessary	
	Frequency parameters programmed wrongly	Check parameters.	
Running pump can not be stopped via X1	Pump has been started via the serial interface, the interface controls the pump	Disconnect the DC supply or connect serial interface and stop via bus	no
Connected accessories do not operate as intended	Accessories incorrectly connected or wrong function code has been set up or function code dependent parameters have not been properly set up.	Check the settings for the function codes and the corresponding parameters OR check to ensure that the accessories have been connected to the correct accessory connection.	no

* Default values for normal operation threshold (P25) and max. run-up time (P32), can be changed via serial interface.

Disposal

Contamination



7 Waste Disposal

The equipment may have been contaminated by the process or by environmental influences. In this case the equipment must be decontaminated in accordance with the relevant regulations. We offer this service at fixed prices.

Contaminated parts can be detrimental to health and environment. Before beginning with any work, first find out whether any parts are contaminated. Adhere to the relevant regulations and take the necessary precautions when handling contaminated parts.

Separate clean components according to their materials, and dispose of these accordingly. We offer this service. Further details are available on request.

When sending us any equipment, observe the regulations given in Section "5.2 Leybold service".

Certificates

The TURBOVAC i have been tested by the TÜV Rheinland of North America according to the requirements of

- IEC 61010-1:2010 (Third Edition)

CB Report No. 21249112 001
CB Certificate No. DE 2020071

- UL 61010-1:2012
CSA C22.2 No. 61010-1-12

cTUVus File No. USA-JE 31381698 005
cTUVus Certificate No. CU 72132224 03

The components are in compliance to the tested standards.

The TÜV Rheinland of North America is a "Nationally Recognized Testing Laboratory" (**NRTL**) for the USA and Canada.



EC Declaration of Incorporation

(Translation of original Declaration of Incorporation)

The manufacturer: Leybold GmbH
Bonner Strasse 498
D-50968 Köln, Germany

herewith declares that the following product:

Product designation: turbo-molecular pump with integrated controller

Type designation:

For pumps with max 3 inlets:

TURBOVAC *a1/a2/a3* i, TURBOVAC T *a1/a2/a3* i

TURBOVAC *a1/a2/a3* iX, TURBOVAC T *a1/a2/a3* iX

TURBOVAC *a1/a2/a3* iC, TURBOVAC T *a1/a2/a3* iC

a1 = 30 until 450, *a2*, *a3* = 1 until 300 (Indices *a2* and *a3* optional)

For pumps with > 3 inlets:

TURBOVAC *numeral m* i

TURBOVAC *numeral m* iC

Numeral= quad, penta, hexa, hepta, octa, nona, deca
(according to the number of inlets (up to 10))

m = 1 until 99

Part number:

8xxxxxVxxxx

8xxxxxVxxxx

8xxxxxVxxxx / 8xxxxxVxxxxC

x= 0 until 9

8xxxxxVxxxx

8xxxxxVxxxx / 8xxxxxVxxxxC

x= 0 until 9

complies with the following fundamental requirements of the **Machinery Directive (2006/42/EC)**:
Annex I, Paragraph 1.1.2, 1.1.3, 1.1.5, 1.2.1, 1.2.3, 1.2.4.1, 1.2.4.2, 1.2.6, 1.3.1, 1.3.2, 1.3.3, 1.3.4, 1.3.7,
1.5.1, 1.5.2, 1.5.4, 1.5.5, 1.5.13, 1.6.1 and 1.7.1

The safety objectives of the Low Voltage Directive 2014/35/EU were complied with in accordance with
Appendix 1 No. 1.5.1 of Machinery Directive 2006/42/EC.

The following harmonised standards have been applied:

EN 1012-2:1996+A1:2009 Compressors and vacuum pumps - Safety requirements
Part 2: Vacuum pumps

EN 60204-1:2006 Safety of machinery - Electrical equipment of machines
Part1: General requirements

The incomplete machine may only be put into operation after it has been determined that the machine into
which the incomplete machine shall be installed complies with the regulations laid down in the EC
Machinery Directive (2006/42/EG).

The manufacturer commits himself to make the special documentation on the incomplete machine
electronically available to national authorities upon request. The special engineering documentation
belonging to the machine was compiled in accordance with Annex VII Part B.

Documentation officer: Herbert Etges
T: +49(0)221 347 0
F: +49(0)221 347 1250
documentation@leybold.com

Cologne, October 11, 2016

Cologne, October 11, 2016



ppa. Martin Tollner
Head of Product Lines



ppa. Dr. Monika Mattern-Klosson
Head of Quality & Business Process Management

Document No.: 300437378-002-A4

EU Declaration of Conformity

(Translation of original Declaration of Conformity)

The manufacturer: Leybold GmbH
Bonner Strasse 498
D-50968 Köln
Germany

herewith declares that the products specified and listed below which we have placed on the market, comply with the applicable EU Council Directives. This declaration becomes invalid if modifications are made to the product without agreement of Leybold GmbH.

Product designation: turbo-molecular pump with integrated controller

Type designation:

For pumps with max 3 inlets:

TURBOVAC *a1/a2/a3* i, TURBOVAC T *a1/a2/a3* i
TURBOVAC *a1/a2/a3* iX, TURBOVAC T *a1/a2/a3* iX
TURBOVAC *a1/a2/a3* iC, TURBOVAC T *a1/a2/a3* iC

a1 = 30 until 450, *a2*, *a3* = 1 until 300 (Indices *a2* and *a3* optional)

For pumps with > 3 inlets:

TURBOVAC *numeral m* i
TURBOVAC *numeral m* iC

Numeral = quad, penta, hexa, hepta, octa, nona, deca
(according to the number of inlets (up to 10))
m = 1 until 99

Part number:

8xxxxxVxxxx
8xxxxxVxxxx
8xxxxxVxxxx / 8xxxxxVxxxxC

x = 0 until 9

8xxxxxVxxxx
8xxxxxVxxxx / 8xxxxxVxxxxC

x = 0 until 9

The products complies to the following European Council Directives:

Electromagnetic Compatibility (2014/30/EU)

The following harmonized standards have been applied:

EN 61326-1:2013 Electrical equipment for measurement, control and laboratory use
EMC requirements — Part 1: General requirements
Emissions: Group 1, Class B ; iX variants = Class A
Immunity: Industrial electromagnetic environment

Documentation officer: Herbert Etges
T: +49(0)221 347 0
F: +49(0)221 347 1250
documentation@leybold.com

Cologne, October 11, 2016

Cologne, October 11, 2016



ppa. Martin Tollner
Head of Product Lines



ppa. Dr. Monika Mattern-Klosson
Head of Quality & Business Process Management

Document No.: 300437378-002-A4

Sales and Service

Germany

Leybold GmbH

Sales, Service, Support Center (3SC)
Bonner Strasse 498
D-50968 Cologne
T: +49-(0)221-347 1234
F: +49-(0)221-347 31234
sales@leybold.com
www.leybold.com

Leybold GmbH

Sales Area North

Branch Office Berlin
Industriestrasse 10b
D-12099 Berlin
T: +49-(0)30-435 609 0
F: +49-(0)30-435 609 10
sales.bn@leybold.com

Leybold GmbH

Sales Office South

Branch Office Munich
Karl-Hammerschmidt-Strasse 34
D-85609 Aschheim-Dornach
T: +49-(0)89-357 33 9-10
F: +49-(0)89-357 33 9-33
sales.mn@leybold.com
service.mn@leybold.com

Leybold Dresden GmbH

Service Competence Center

Zur Wetterwarte 50, Haus 304
D-01109 Dresden
Service:
T: +49-(0)351-88 55 00
F: +49-(0)351-88 55 041
info.dr@leybold.com

Europe

Belgium

Leybold Nederland B.V.

Belgisch bijkantoor

Leuvensesteenweg 542-9A
B-1930 Zaventem
Sales:
T: +32-2-711 00 83
F: +32-2-720 83 38
sales.zv@leybold.com
Service:
T: +32-2-711 00 82
F: +32-2-720 83 38
service.zv@leybold.com

France

Leybold France S.A.S.

Parc du Technopolis, Bâtiment Beta
3, Avenue du Canada
F-91940 Les Ulis cedex
Sales and Service:
T: +33-1-69 82 48 00
F: +33-1-69 07 57 38
info.ctb@leybold.com
sales.ctb@leybold.com

Leybold France S.A.S.

Valence Factory
640, Rue A. Bergès
B.P. 107
F-26501 Bourg-lès-Valence Cedex
T: +33-4-75 82 33 00
F: +33-4-75 82 92 69
marketing.vc@leybold.com

Great Britain

Leybold UK LTD.

Unit 9
Silverglade Business Park
Leatherhead Road
Chessington
Surrey (London)
KT9 2QL
Sales:
T: +44-13-7273 7300
F: +44-13-7273 7301
sales.ln@leybold.com
Service:
T: +44-13-7273 7320
F: +44-13-7273 7303
service.ln@leybold.com

Italy

Leybold Italia S.r.l.

Via Trasimeno 8
I-20128 Mailand
Sales:
T: +39-02-27 22 31
F: +39-02-27 20 96 41
sales.mi@leybold.com
Service:
T: +39-02-27 22 31
F: +39-02-27 22 32 17
service.mi@leybold.com

Netherlands

Leybold Nederland B.V.

Floridadreef 102
NL-3565 AM Utrecht
Sales and Service:
T: +31-(30) 242 63 30
F: +31-(30) 242 63 31
sales.ut@leybold.com
service.ut@leybold.com

Switzerland

Leybold Schweiz AG, Pfäffikon

Churerstrasse 120
CH-8808 Pfäffikon
Warehouse and shipping address:
Riedthofstrasse 214
CH-8105 Regensdorf
Sales:
T: +41-44-308 40 50
F: +41-44-302 43 73
sales.zh@leybold.com
Service:
T: +41-44-308 40 62
F: +41-44-308 40 60
service.zh@leybold.com

Spain

Leybold Spain, S.A.

C/. Huelva, 7
E-08940 Cornellà de Llobregat
(Barcelona)
Sales:
T: +34-93-666 43 11
F: +34-93-666 43 70
sales.ba@leybold.com
Service:
T: +34-93-666 46 11
F: +34-93-685 43 70
service.ba@leybold.com

America

USA

Leybold USA Inc.

5700 Mellon Road
USA-Export, PA 15632
T: +1-724-327-5700
F: +1-724-325-3577
info.ex@leybold.com
Sales:
T: +1-724-327-5700
F: +1-724-333-1217
Service:
T: +1-724-327-5700
F: +1-724-325-3577

Brazil

Leybold do Brasil

Rod. Vice-Prefeito Hermenegildo Tonolli,
nº. 4413 - 6B
Distrito Industrial
Jundiaí - SP
CEP 13.213-086
Sales and Service:
T: +55 11 3395 3180
F: +55 11 99467 5934
sales.ju@leybold.com
service.ju@leybold.com

Asia

P. R. China

Leybold (Tianjin)

International Trade Co. Ltd.

Beichen Economic
Development Area (BEDA),
No. 8 Western Shuangchen Road
Tianjin 300400
China
Sales and Service:
T: +86-22-2697 0808
F: +86-22-2697 4061
F: +86-22-2697 2017
sales.tj@leybold.com
service.tj@leybold.com

India

Leybold India Pvt Ltd.

No. 82(P), 4th Phase
K.I.A.D.B. Plot
Bommasandra Industrial Area
Bangalore - 560 099
Indien
Sales and Service:
T: +91-80-2783 9925
F: +91-80-2783 9926
sales.bgl@leybold.com
service.bgl@leybold.com

Japan

Leybold Japan Co., Ltd.

Headquarters
Shin-Yokohama A.K.Bldg., 4th floor
3-23-3, Shin-Yokohama
Kohoku-ku, Yokohama-shi
Kanawaga 222-0033
Japan
Sales:
T: +81-45-471-3330
F: +81-45-471-3323
sales.yh@leybold.com

Leybold Japan Co., Ltd.

Tsukuba Technical Service Center
1959, Kami-yokoba
Tsukuba-shi, Ibaraki-shi 305-0854
Japan
Service:
T: +81-29 839 5480
F: +81-29 839 5485
service.iik@leybold.com

Malaysia

Leybold Malaysia

Leybold Singapore Pte Ltd.

No. 1 Jalan Hi-Tech 2/6
Kulim Hi-Tech Park
Kulim, Kedah Darul
Aman 09000
Malaysia
Sales and Service:
T: +604 4020 222
F: +604 4020 221
sales.ku@leybold.com
service.ku@leybold.com

South Korea

Leybold Korea Ltd.

3F. Jellzone 2 Tower
Jeongja-dong 159-4
Bundang-gu Sungnam-si
Gyeonggi-do
Bundang 463-384, Korea
Sales:
T: +82-31 785 1367
F: +82-31 785 1359
sales.bd@leybold.com
Service:
623-7, Upsung-Dong
Cheonan-Si
Chungcheongnam-Do
Korea 330-290
T: +82-41 589 3035
F: +82-41 588 0166
service.cn@leybold.com

Singapore

Leybold Singapore Pte Ltd.

8 Commonwealth Lane #01-01
Singapore 149555
Singapore
Sales and Service:
T: +65-6303 7030
F: +65-6773 0039
sales.sg@leybold.com
service.sg@leybold.com

Taiwan

Leybold Taiwan Ltd.

No 416-1, Sec. 3
Chunghsin Rd., Chutung
Hsinchu County 310
Taiwan, R.O.C.
Sales and Service:
T: +886-3-500 1688
F: +886-3-583 3999
sales.hc@leybold.com
service.hc@leybold.com

Headquarter

Leybold GmbH

Bonner Strasse 498
D-50968 Cologne
T: +49-(0)221-347-0
F: +49-(0)221-347-1250
info@leybold.com



www.leybold.com