



Why **TURBOVAC** i?

The Ultimate Vacuum Performance



Why TURBOVAC i?



Why use the Leybold TURBOVAC i/iX?

Designed to offer the best performance, the TURBOVAC i/iX series has a **higher pumping speed** and delivers **lower initial and operating costs**. With its exceptional features such as light gas pumping speeds of up to 60% above present reference products, and compression values that are approximately 100x higher than previous generation products, it is **the right choice for all your applications**.

✓ From pumping speed 90 l/s to 1390 l/s

The TURBOVAC i/iX range covers pumping speeds up to 1390 l class.

✓ From serviceability to active bearing management

A pump generation for stress-free operation and service where the pump actively manages the bearing, and bearing replacement on-site is possible.

✓ From IP40 to IP54

While all TURBOVAC i/iX pumps offer IP40 as standard, IP54 is an option for protection in industrial and coating environments.

✓ Stress-Free Operation

Robustness increases your productivity and system uptime.

- Proven reliability and consistent performance across a range of processes and demanding applications.
- Fit & Forget, user friendly and highly dependable installation and operation.
- Robust against mechanical impact and harsh venting.
- Optimized rotor design for optimum pumping performance.

✓ Exceptional Performance

TURBOVAC i/iX has been designed to optimize both pumping speed performance and compression ratio.

- Unique pump stages design to deliver excellent performance also process applications with increased gas flows.
- Light gas pumping speeds of up to 60% above present reference products.
- Compression values 100 times higher than previous generation products.
- Wide range of performance variants.

That's why!



As the world's oldest vacuum pump manufacturer, Leybold's pioneering inventions, such as the first molecular air pump in 1909, paved the way for other vacuum technologies, including turbomolecular pumps, which are critical in many modern-day applications.

✓ Minimal Application Impact

TURBOVAC i/iX is the first and only mechanical turbomolecular pump with our unique oil-free hybrid bearing concept and lifetime-lubricated ball bearings.

- Low vibration design for reduced noise, mechanical stress and negative impact on vibration sensitive applications.
- Clean oil-free bearings ensure maintenance free operation and zero contamination.

✓ Flexible Platform & Control Options

A wide choice of customer interfaces is available across TURBOVAC i/iX range.

- Integrated electronics and a variety of options for communication and control.
- Installation in any orientation for ease of system integration.
- Variable rotor and drag stage configurations to perfectly match your application requirements.
- Flexible from port position to fully customized products.

✓ The Leybold Promise

Our pioneering spirit and expertise shapes the future we build together.

- We are the reliable experts in vacuum.
- Our sales and applications teams will help you specify the right solution.
- Our commitment to continuous improvement and passion for exploring new ideas drives product innovation in the most advanced and complex applications.
- Building long-lasting relationships since 1850

Why TURBOVAC i?

Analytics

- Electron microscopy
- Leak detection
- Mass spectrometry
- Surface analysis
- Plasma monitoring
- Residual gas analysis

Research & Development

- Particle accelerators
- Fusion technology
- Plasma research
- Space simulation
- Cryogenic research
- Elementary particle physics
- Nanotechnology
- Biotechnology
- Nuclear Research

Multitude of applications & wide range of off the shelf solutions

That's why!

The Leybold TURBOVAC i/X turbomolecular pumps are highly versatile and are therefore suited for a wide range of applications in Research & Development, Analytical, Life Sciences and Industrial sectors.

The pump range consists of a large number of variants and accessories meeting the requirements of your process, aimed at providing the best possible performance.



That's why!

Industry & Coating

- Flat Panel Display (FPD)
- LED / OLED
- Hard disk coating
- Photovoltaics
- Glass coating (PVD)
- CD/DVD/Blu ray production
- Optical coating (PVD)
- Web coating
- Medical technology
- Industrial leak detection
- Electron beam welding
- Isolation vacuums, lamp & tube manufacturing
- Heat treatment
- Vacuum drying
- Vacuum furnaces

Customised products delivered by our dedicated Customer Focused Engineering team.

That's Why!

When customized pumps are needed for integration into your instrument or volume application, the **Leybold Customer Focus Engineering (CFE) team is dedicated to delivering to your specification.**

The team will manage all aspects of the process from requirements gathering to prototyping products in typically 12 weeks or less. They will also ensure availability of volume pump supply when you need it.

The team is committed to making cooperation with Leybold on customized products simple and fast, and to work out high quality solutions to meet your needs.



Why TURBOVAC i?



All about the range. All about the benefits.

BENEFITS	TURBOVAC i		TURBOVAC iX
	Compact standard interface	Anybus front end	
Pumping speeds: 90, 250, 350, 450, 850, 925		✓	
Pumping speeds: 1350 and 1390	✓		
High compression for all gases		✓	
Oil free sealed for bearings with long lifetime		✓	
Full range of venting and purging option		✓	
Operation in any orientation		✓	
Customized products		✓	
Compatible with LeyAssit PC software		✓	
Digital I/O interface		✓	
3 LED status indicators		✓	
USB port		✓	
Standard RS485 Interface	✓		
Full Field Bus support (RS232, RS485, ProfiBUS, ProfiNET, Ethernet, EtherCAT etc.)			✓
Upgradeable to IP54 for models 850, 950, 1350, 1450		✓	
Ports to control ancillary devices (Air cooler, Valves, Relay box...)		1 port	3 ports
Smart backing pump control			✓
Regulate pump gauge interface & share pressure data			✓
Ability to function as a basic vacuum controller			✓

That's why!

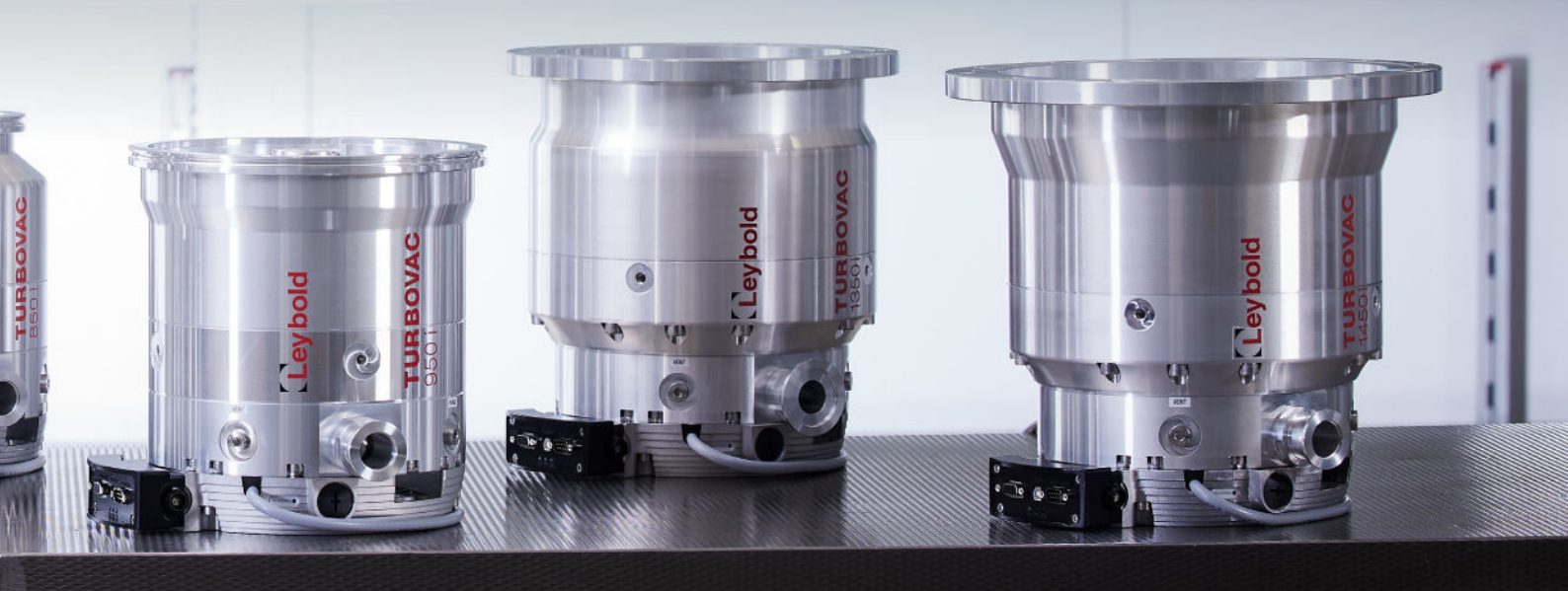

One core platform. Two interface standards.

TURBOVAC i pumps are available with two selectable interfaces.

- The **compact standard interface** has RS485, USB & Digital I/O interfaces with 3 status LED's and the possibility to control 1 accessory.
- The **Anybus interface** is a step up with full field bus support and the option to upgrade to IP54 water & dust ingress resistance.

TURBOVAC iX pumps extend the functionality of your pump enabling it to act as your controller in your vacuum system.

The iX range also comes with full communication protocol and fieldbus support.

Control up to 6 accessories as well as your backing pump, making these models a true vacuum solution.



Technical specifications

TURBOVAC		90 i/iX	250 i/iX	350 i/iX	450 i/iX
High-vacuum connection	DN	63 ISO-K / CF	100 ISO-K / CF	100 ISO-K / CF	160 ISO-K / CF
Fore-vacuum connection	DN	16 KF	16 KF	25 KF	25 KF
Pumping speed for N ₂ Ar He H ₂	l · s ⁻¹	90 83 90 78	225 210 250 210	290 260 360 350	430 400 440 420
Gas throughput N ₂ Ar He H ₂	mbar · l · s ⁻¹	10 3 11 11	6 3 6 > 10	4.5 2.0 8.0 8.0	4.5 2.0 8.0 8.0
Compression ratio N ₂ Ar He H ₂		> 1 · 10 ¹¹ > 1 · 10 ¹¹ 1 · 10 ⁸ 5 · 10 ⁷	> 1 · 10 ¹¹ > 1 · 10 ¹¹ 1 · 10 ⁸ 2 · 10 ⁷	> 1 · 10 ¹¹ > 1 · 10 ¹¹ 1 · 10 ⁸ 1 · 10 ⁶	> 1 · 10 ¹¹ > 1 · 10 ¹¹ 1 · 10 ⁸ 1 · 10 ⁶
Ultimate pressure ISO-K/CF with 2-stage oil-sealed rotary vane pump	mbar	≤ 8 · 10 ⁻⁸ / ≤ 5 · 10 ⁻¹⁰			
Max. permissible fore-vacuum pressure for N ₂	mbar	14		10	
Operating speed	rpm	72 000			
Cooling standard		Convection			
Cooling optional		Air or water			
Weight ISO-K/CF	kg	3.5 / 5.3	4.5 / 7.1	7.5 / 11.5	7.7 / 12.5
Recommended fore-vacuum pumps	TRIVAC SCROLLVAC DIVAC	D 2,5 B / D 4 B SC 7 plus 3.8 HV3	D 2,5 B / D 4 B SC 7 /15 plus 3.8 HV3	D 4 B SC 7/15 plus 3.8 HV3	D 4 B SC 7 /15 plus 3.8 HV3
Supply voltage		24/48V DC ± 10 %			
Max. current consumption		10A at 24V DC			
Max. power consumption	W	240			
Interfaces	i Versions iX Versions	RS 485, USB, 15-pin digital I/O (additional on request) Optional RS 485, RS 232, Profibus (additional on request)			

TURBOVAC		850 i/iX	950 i/iX	1350 i	1450 i
High-vacuum connection	DN	160 ISO-K / CF	200 ISO-K / CF	200 ISO-K / ISO-F	250 ISO-K / ISO-F
Fore-vacuum connection	DN	25 KF	25 KF	40 KF	40 KF
Pumping speed for N ₂ Ar He H ₂	l · s ⁻¹	720 655 850 755	900 840 925 770	1250 1150 1350 1150	1380 1280 1390 1210
Gas throughput (*) N ₂ Ar He H ₂	mbar · l · s ⁻¹	14 3,5 21 >15	14 3,5 21 > 15	> 24 ** 12 18 10	> 24 ** 12 18 10
Compression ratio N ₂ Ar He H ₂		> 1 · 10 ¹¹ > 1 · 10 ¹¹ 1,3 · 10 ⁸ 4,4 · 10 ⁶	> 1 · 10 ¹¹ > 1 · 10 ¹¹ 1,3 · 10 ⁸ 4,4 · 10 ⁶	> 1 · 10 ⁸ > 1 · 10 ⁸ 4 · 10 ⁵ 2 · 10 ⁴	> 1 · 10 ⁸ > 1 · 10 ⁸ 4 · 10 ⁵ 2 · 10 ⁴
Ultimate pressure ISO-K/CF with 2-stage oil-sealed rotary vane pump	mbar	3 · 10 ⁻⁸ / 3 · 10 ⁻¹⁰		< 7,5 · 10 ⁻⁹	
Max. permissible fore-vacuum pressure for N ₂	mbar	15		4	
Operating speed	min ⁻¹	49 200		42 000	
Cooling standard		Convection		Water	
Cooling optional		Air or water			
Weight ISO-K/CF	kg	14,6 / 19,6	15,4 / 21,7	23,5 / 24,3	24,4 / 25,5
Recommended fore-vacuum pumps	ECODRY SCROLLVAC DIVAC	65 plus SC 7 plus 3.8 HV3			
Supply voltage		48V DC + 5 % / - 10 %			
Max. current consumption		13A at 48V DC			
Max. power consumption	W	600		800	
Interfaces		see ordering data			

(*) If working with lighter gases contact Leybold applications team for a boosted gas throughput

(**) Contact Leybold for high gas throughput of Nitrogen

Technical specifications

TURBOVAC 90 i

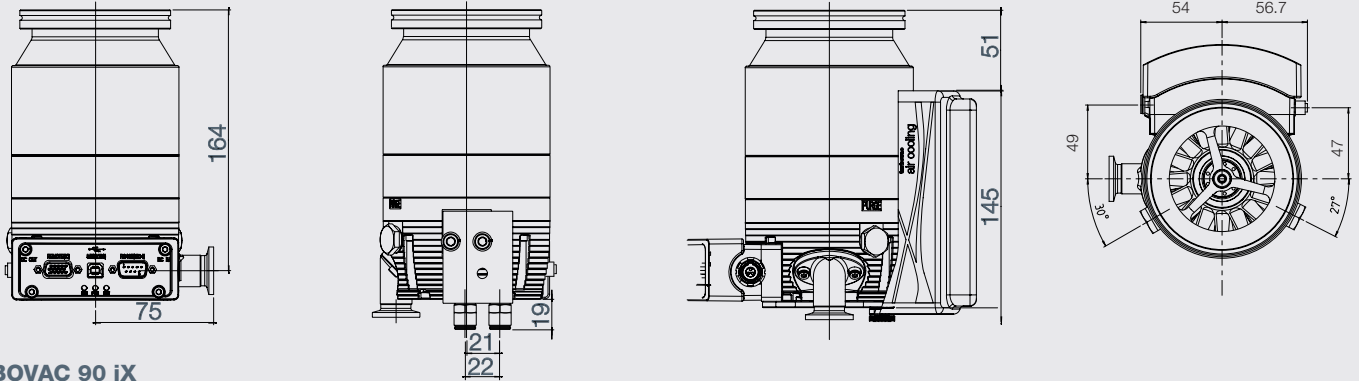

TURBOVAC 90 iX

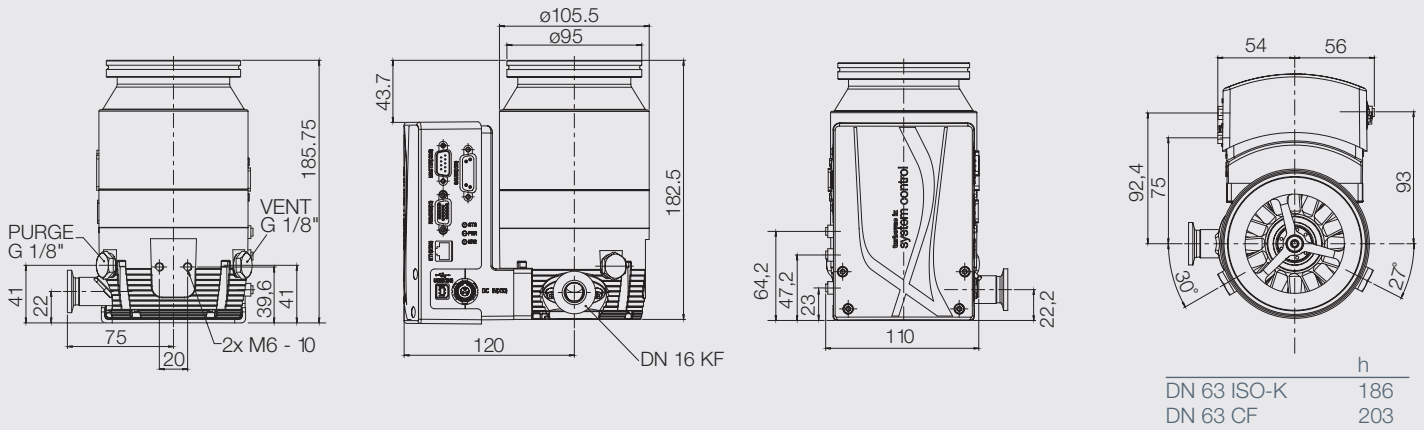

TURBOVAC 250 i

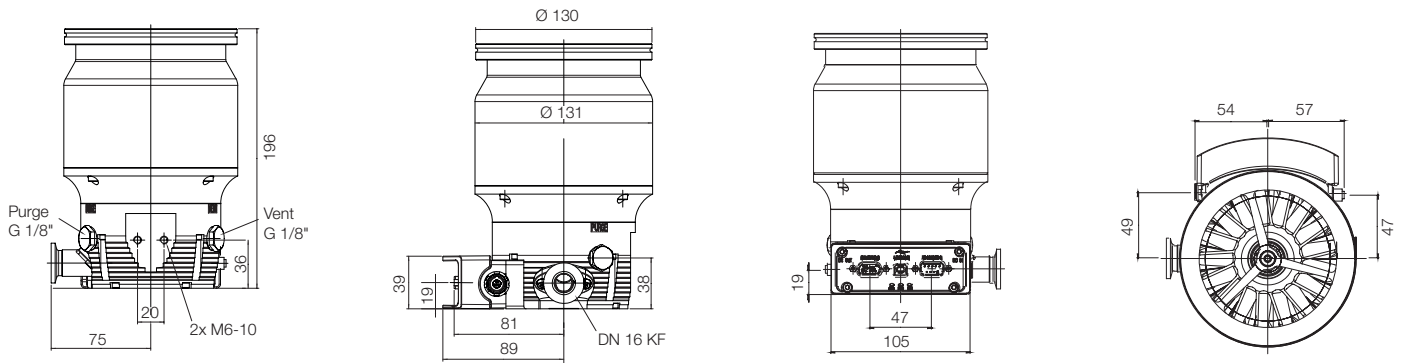

TURBOVAC 250 iX

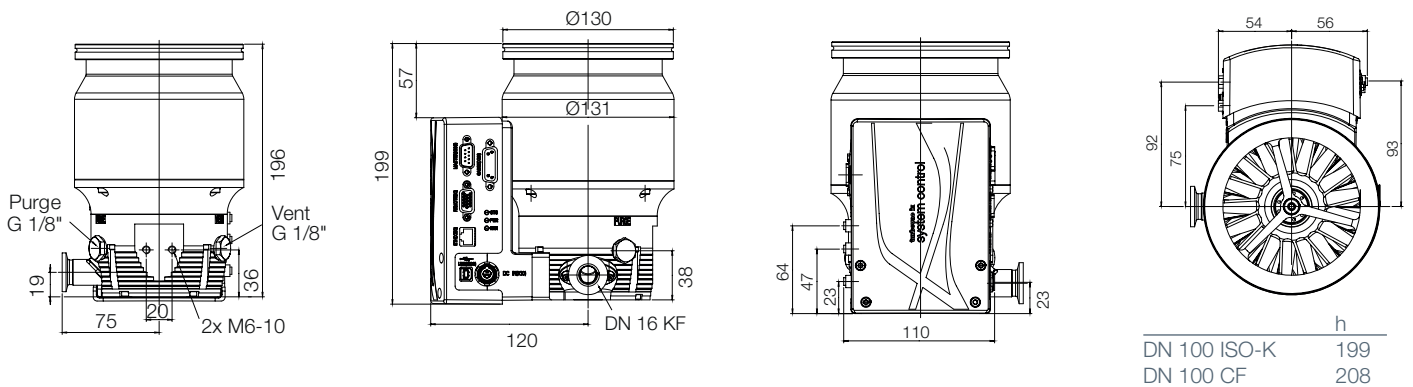

TURBOVAC 350 i

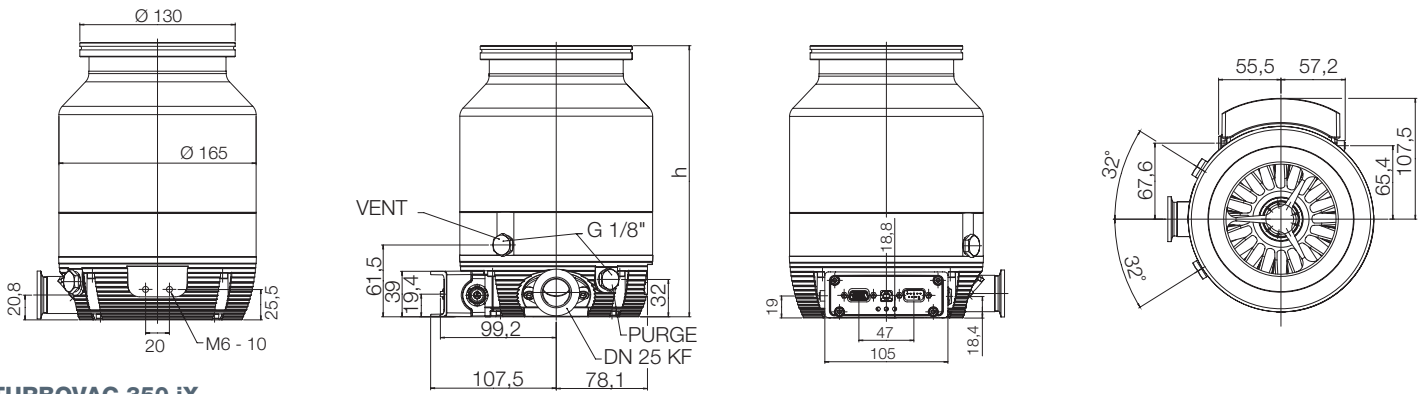

TURBOVAC 350 iX

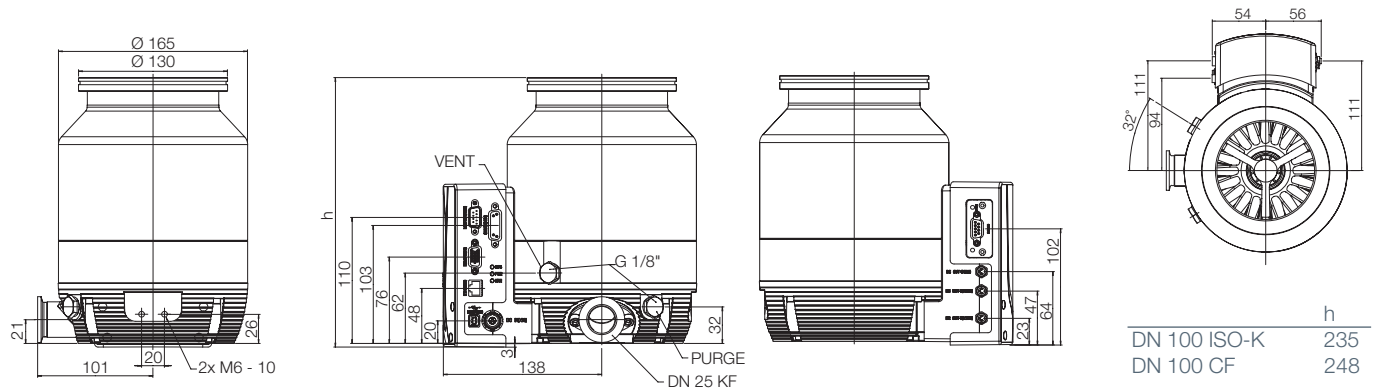

TURBOVAC 450 i

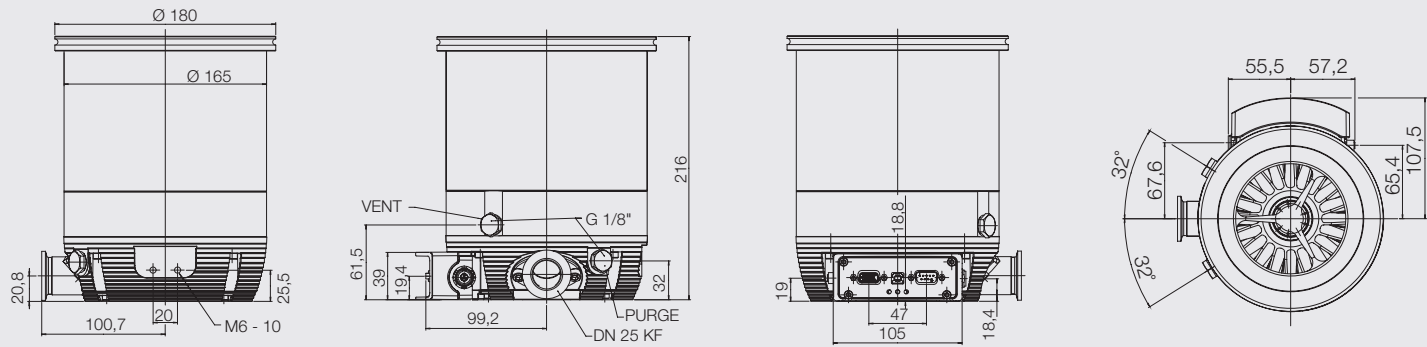

TURBOVAC 450 iX

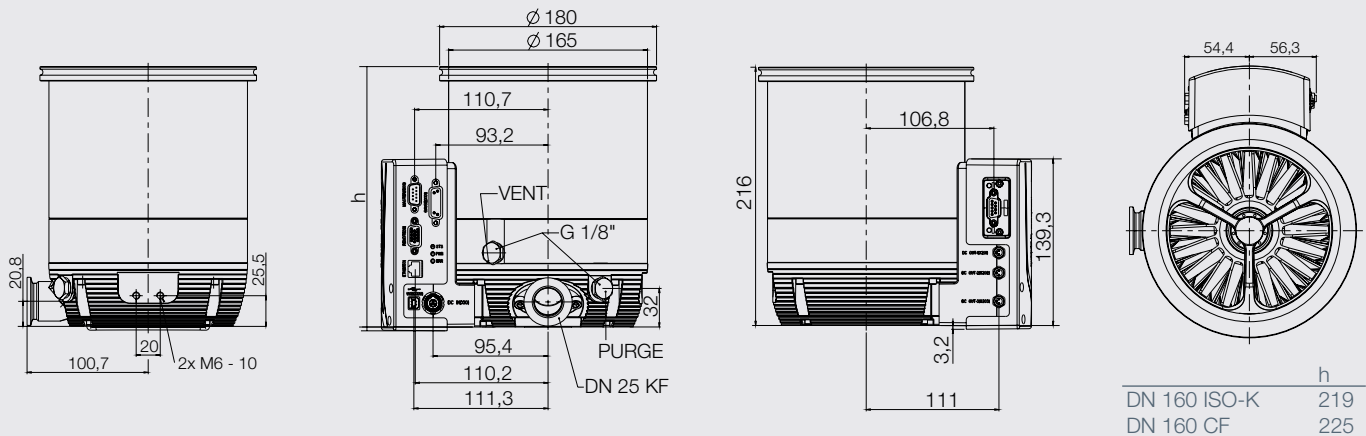

Technical specifications

TURBOVAC 850 i

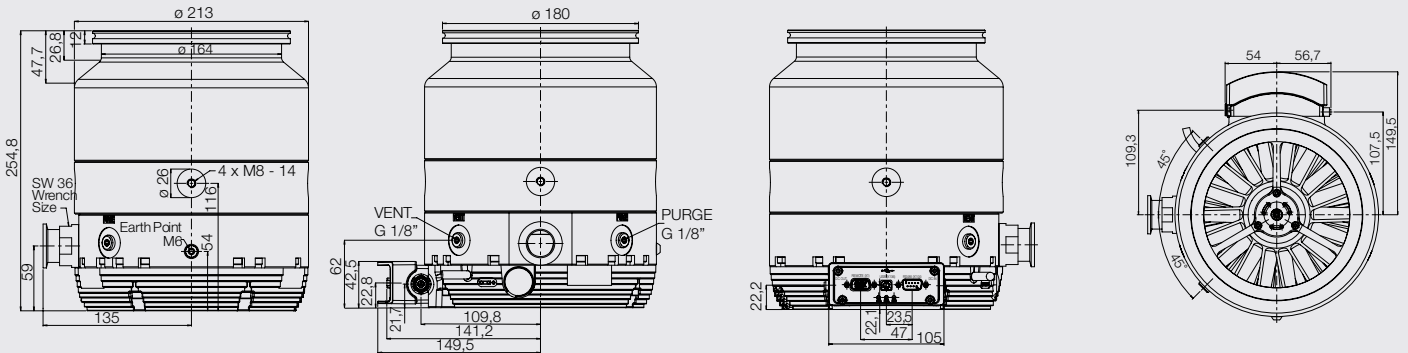

TURBOVAC 850 iX

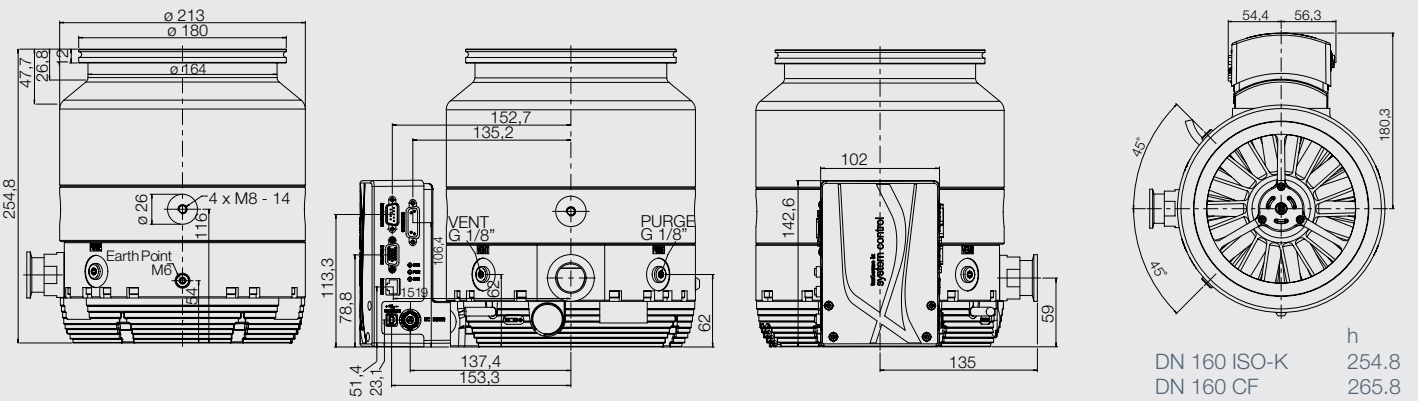

TURBOVAC 950 i

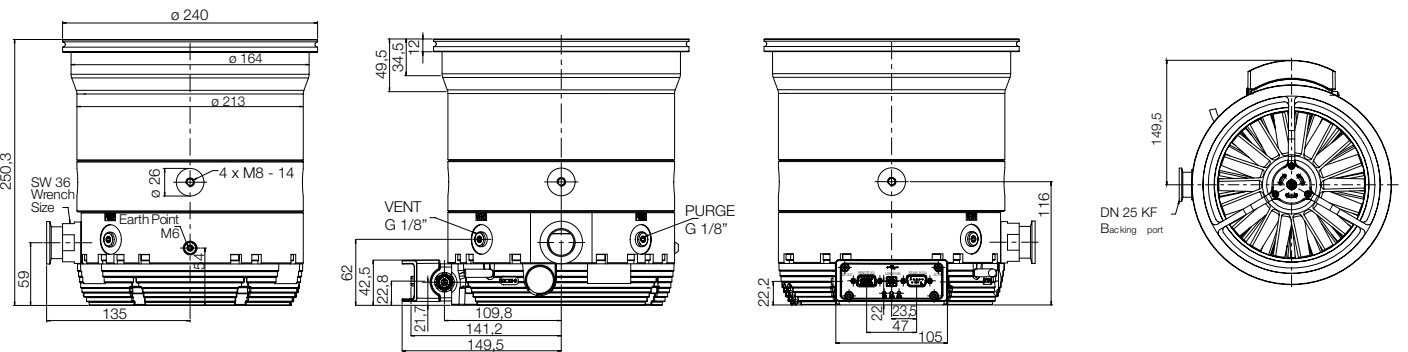

TURBOVAC 950 iX

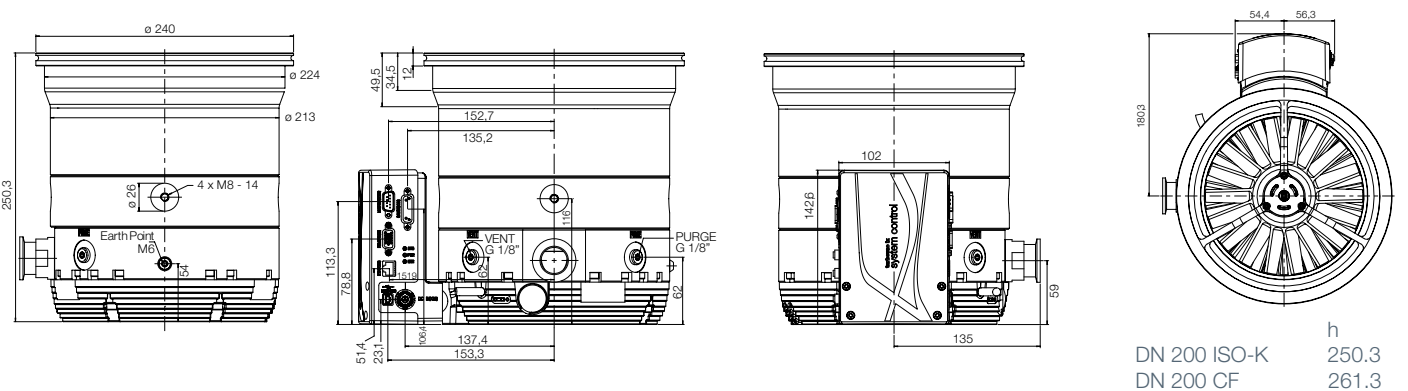

TURBOVAC 1350 i

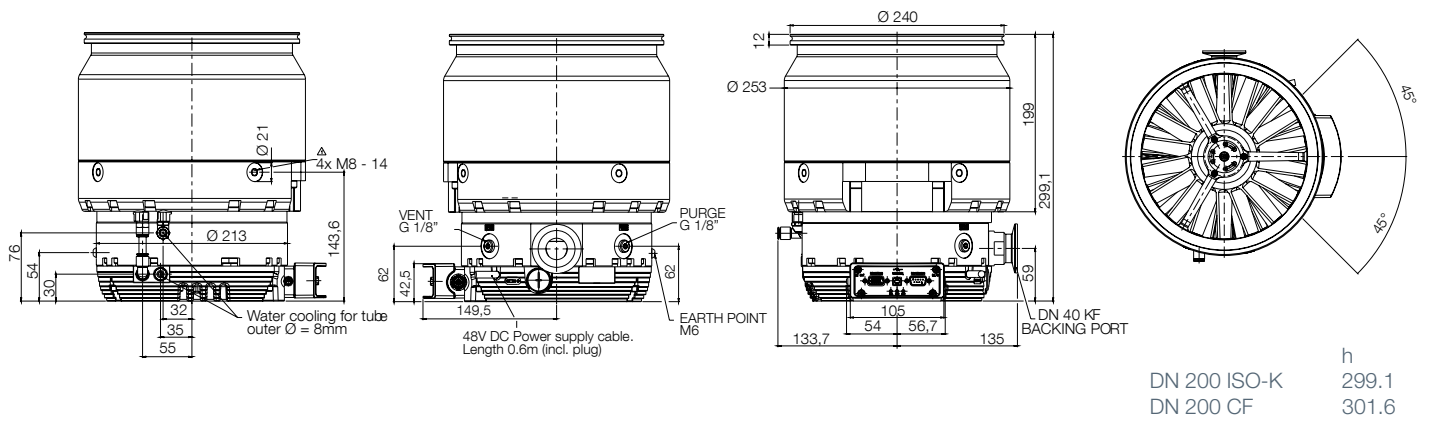

TURBOVAC 1450 i

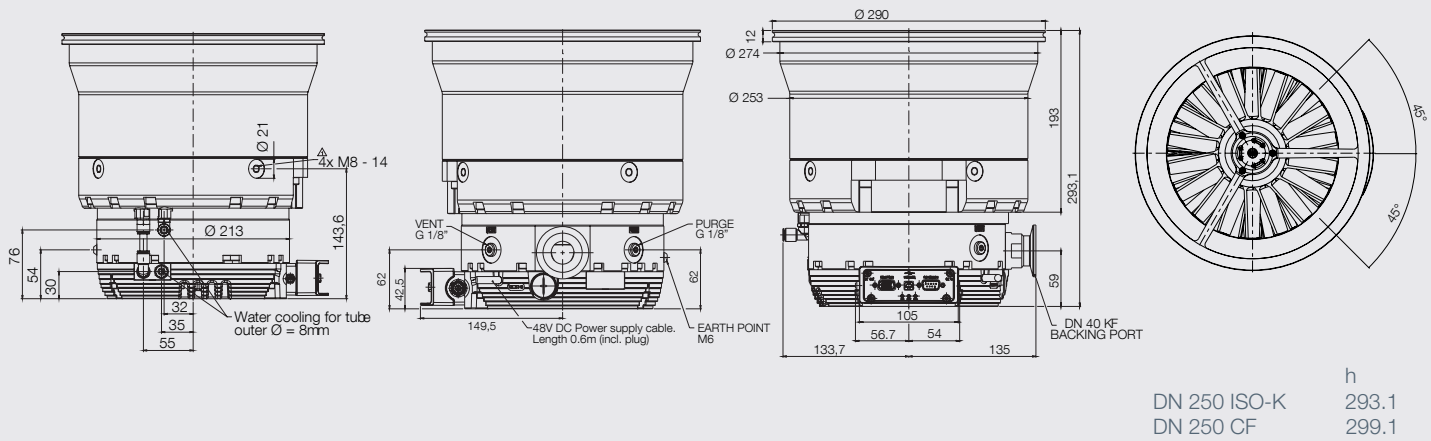

Technical specifications

TURBOVAC 90 i/iX

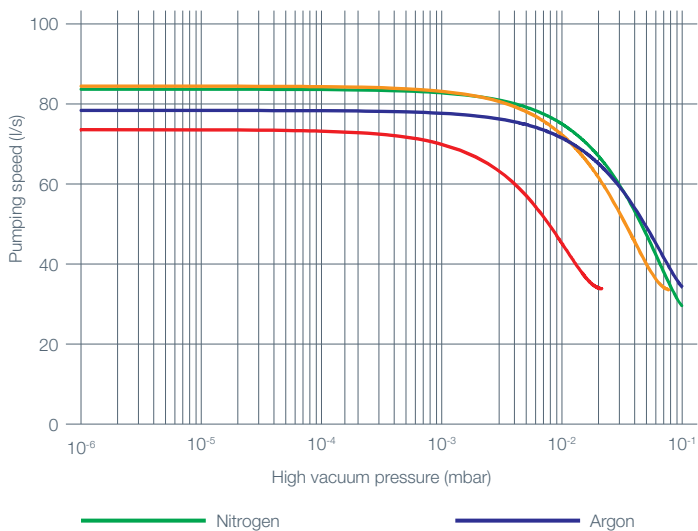

TURBOVAC 250 i/iX

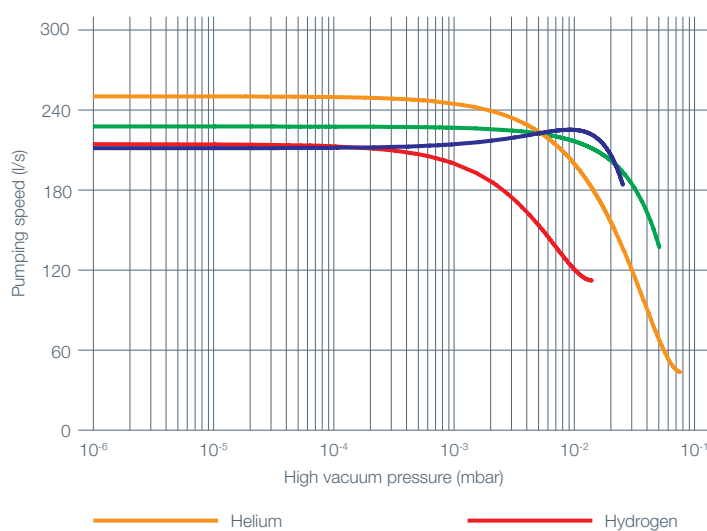

TURBOVAC 350 i/iX

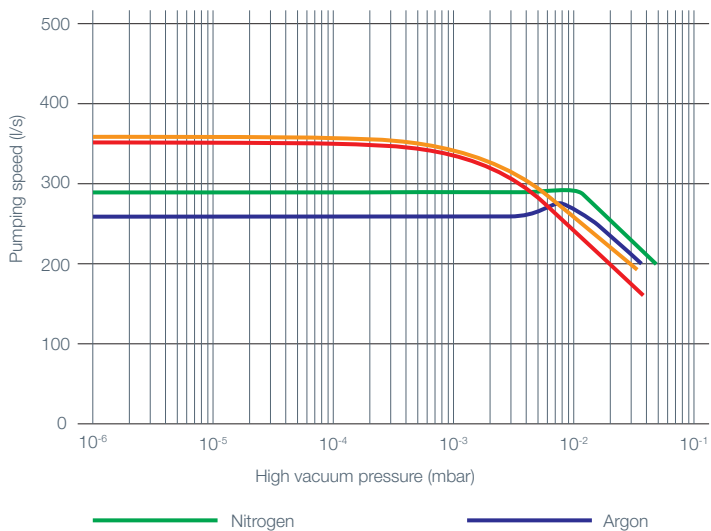

TURBOVAC 450 i/iX

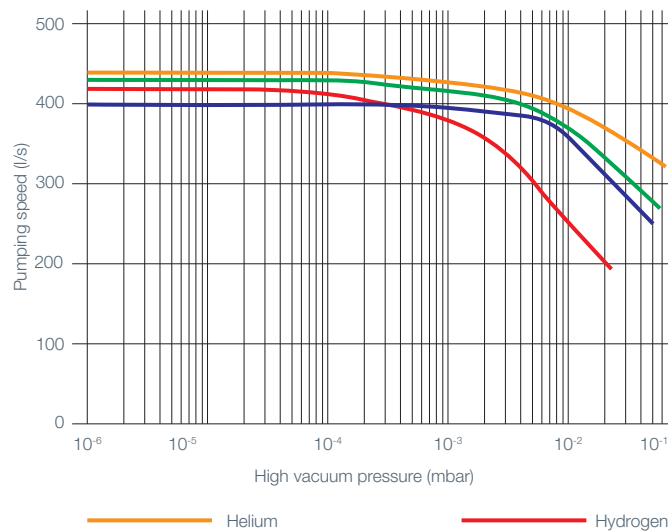

TURBOVAC 850 i/iX

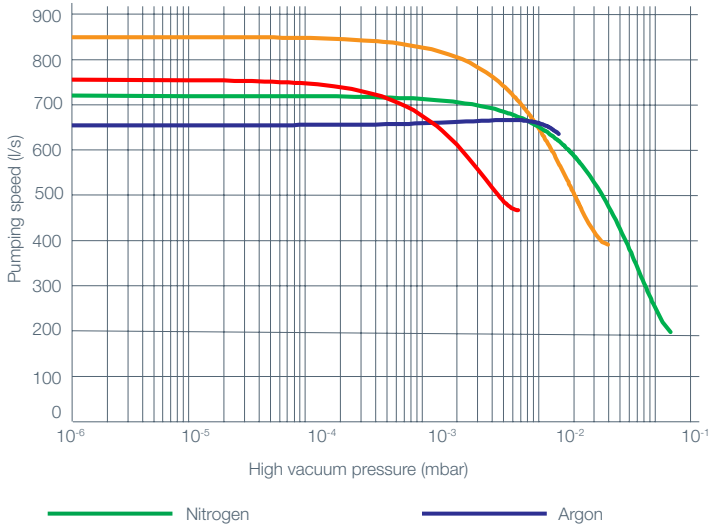

TURBOVAC 950 i/iX

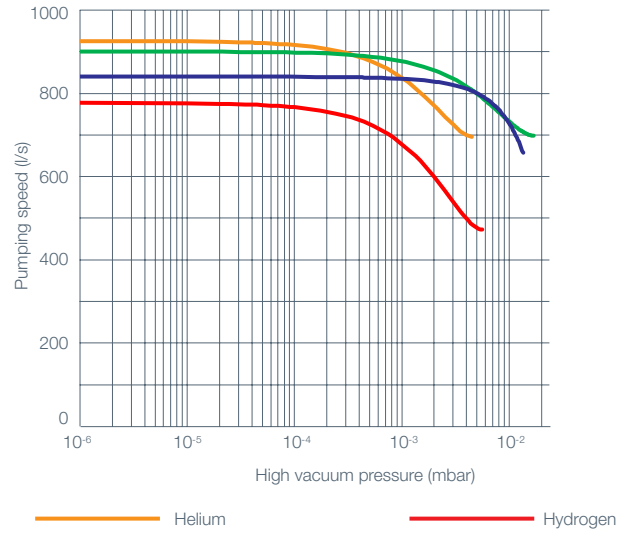

TURBOVAC 1350 i

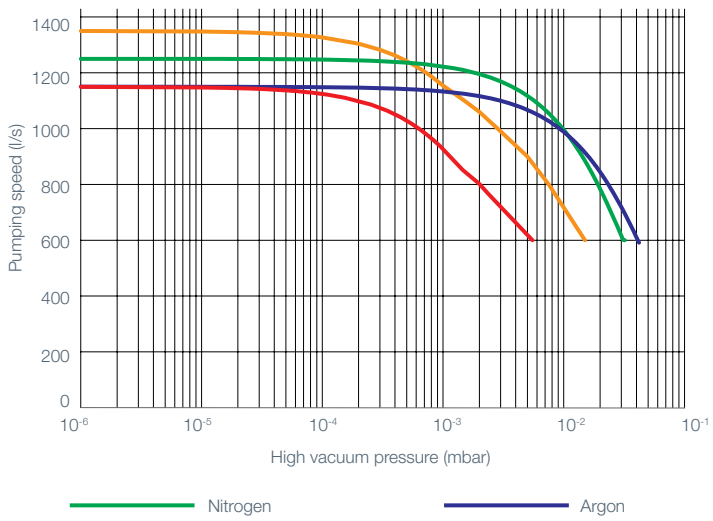

TURBOVAC 1450 i

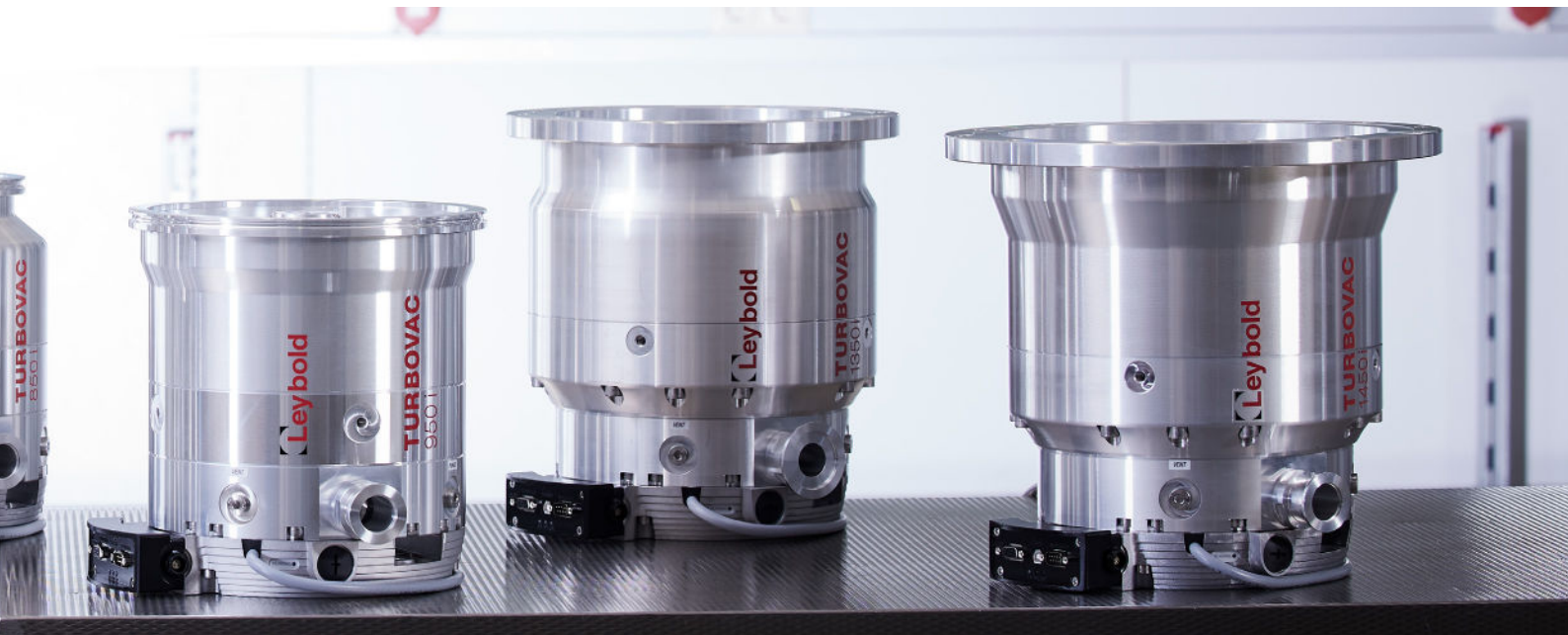
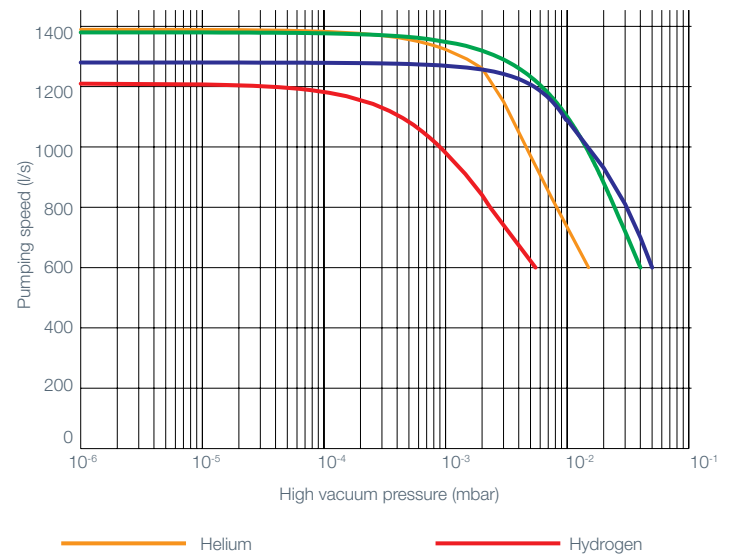

Accessories

		90 i/iX	250 i/iX	350 i/iX	450 i/iX	850 i/iX	950 i/iX	1350 i	1450 i
Power supply, cables and accessories									
800100V0003	TURBO.POWER integra (TPI) incl. cable 0.3 m		✓						
800100V0005	Mounting kit TPI	✓							
	Mounting kit TPI			Standard					
800096V0100	Cable TURBOVAC i/iX – TURBO.POWER integra, 1 m		✓						
800096V0300	Cable TURBOVAC i/iX – TURBO.POWER integra, 3 m		✓						
800096V0500	Cable TURBOVAC i/iX – TURBO.POWER integra, 5 m		✓						
800102V0002	Mains cable for power supplies, 3 m, EC plug					✓			
800102V0003	Mains cable for power supplies, 3 m, UK plug					✓			
800102V1002	Mains cable for power supplies, 3 m, US plug					✓			
800110V0016	Accessory cable TURBOVAC i, M8-M8, 2m					✓			
800110V0020	Y cable TURBOVAC i/iX, M8					✓			
800110V0021	Start stop switch for TURBOVAC i/iX					✓			
800110V0108	USB cable 2.0 Type A/B, 1.8 m					✓			
800110V0030	Relay box for fore vacuum pump, 1-phase, 10A, incl. 2 m M8-M8 cable					✓			
800100V0010	TURBO.POWER 800							✓	
800100V0110	Mounting kit TURBO.POWER 800							✓	
800096V0303	Cable TURBOVAC i/iX – TURBO.POWER 800, 3 m							✓	
800096V0503	Cable TURBOVAC i/iX – TURBO.POWER 800, 5 m							✓	
800096V0101	Cable TURBOVAC i/iX – open end, 1 m							✓	
800096V0301	Cable TURBOVAC i/iX – open end, 3 m							✓	
800096V0501	Cable TURBOVAC i/iX – open end, 5 m							✓	
Control									
800100V0004	TURBO.CONTROL i					✓			
800110V0028	Table top housing					✓			
800110V0027	Power supply 24 VDC / 1.5 A					✓			
Venting and Purge									
800120V0012	Venting valve, 24 V DC, G 1/8"					✓			
800120V0013	Purge gas valve, 24V DC, 24 sccm, G 1/8"					✓			
800120V0014	Purge gas throttle, 24 sccm, G 1/8"					✓			
800120V0022	Power failure venting valve, 24V DC, G 1/8"					✓			
800110V0022	Air filter, G 1/8"					✓			

		90 i/iX	250 i/iX	350 i/iX	450 i/iX	850 i/iX	950 i/iX	1350 i	1450 i
Cooling									
800136V0007	Air cooling radial	✓							
800136V0009	Air cooling radial		✓						
800136V0005	Air cooling radial			✓					
800136V0011	Air cooling radial					✓			
800136V0008	Air cooling axial	✓							
800136V0006	Air cooling axial			✓					
800135V0005	Water cooling		✓						
800135V0006	Water cooling, G 1/4"		✓						
800135V0007	Water cooling					✓			
	Water cooling								Standard
Heating									
800137V0003	Flange heating DN 63 CF, 230 V	✓							
800137V0004	Flange heating DN 63 CF, 115 V	✓							
800137V0005	Flange heating DN 100 CF, 230V		✓						
800137V0006	Flange heating DN 100 CF, 115V		✓						
800137V0007	Flange heating DN 160 CF, 230V				✓				
800137V0008	Flange heating DN 160 CF, 115V				✓				
Anybus Modules									
410300V0902	Anybus RS232 Module					✓			
410300V0903	Anybus RS485 Module					✓			
410300V0904	Anybus Profibus M40 Module		✓						
410300V0906	Anybus Ethernet Module		✓						
410300V0905	Anybus Profinet IRT Module		✓						
410300V0907	Anybus EtherCAT Module		✓						
410300V0908	IP54 Anybus Profibus M40 Module						✓		
410300V0909	IP54 Anybus Profinet IRT Module						✓		
410300V0910	IP54 Anybus Ethernet Module						✓		
410300V0911	IP54 Anybus EtherCAT Module						✓		

Order information

For operating TURBOVAC i/iX: a suitable fore vacuum pump, a power supply as well as a DC/mains cable are mandatory. Further accessories might be required depending on the application and operating conditions.

Models	High Vacuum Flange	Flange Type Part Number (PN)				Compact Interface	Anybus Front End	Dedicated inverted use variant
		DN	KF	DN ISO-K	DN ISO-F			
TURBOVAC i	DN	KF	DN ISO-K	DN ISO-F	DN CF	V1000	V2000	U
	40	810011				√	√	
90 i	63		810031		810041	√	√	
250 i	100		820051		820061	√	√	
350 i	100		830051		830061	√	√	
450 i	160		830071		830081	√	√	
850 i	160		840071		840081	√	√	
950 i	200		840091		840091	√	√	
1350 i	200		850092	850102		√	√	√
1450 i	250		850122	850132		√	√	√

Models	High Vacuum Flange	Flange Type Part Number (PN)		Preselected RS485
		DN ISO-K (KF)	DN CF	
TURBOVAC iX	DN	DN ISO-K (KF)	DN CF	ISO-K
	40	(810011V3000)		810011V3300
90 iX	63	810031V3000	810041V3000	810031V3300
250 iX	100	820051V3000	820061V3000	820051V3300
350 iX	100	830051V3000	830061V3000	830051V3300
450 iX	160	830071V3000	830081V3000	830071V3300
850 iX	160	840071V3000	840081V3000	840071V3300
950 iX	200	840091V3000	840091V3000	840091V3300

All part numbers come with USB, 15 pin digital I/O

- V1000 comes with standard RS485 connection
- V2000 has full field support with the anybus module and optional
- V3000 describes Turbovac iX which makes your pump a vacuum solution
- For more details on interface please see dedicated table

To create full Part Number:

Combine the flange dimension & type with the front end of choice and select U variant if required.

Example: TURBOVAC 1450i with ISO-F and Anybus for inverted use = 850132V2000U



Pioneering products. Passionately applied.