



OPERATING INSTRUCTIONS

EN

Translation of the Original

HENA 61 | 101

Rotary vane pump

PFEIFFER  **VACUUM**

Dear Customer,

Thank you for choosing a Pfeiffer Vacuum product. Your new rotary vane pump is designed to support you by its performance, its perfect operation and without interfering your individual application. The name Pfeiffer Vacuum stands for high-quality vacuum technology, a comprehensive and complete range of top-quality products and first-class service. With this expertise, we have acquired a multitude of skills contributing to an efficient and secure implementation of our product.

Knowing that our product must not interfere with your actual work, we are convinced that our product offers you the solution that supports you in the effective and trouble-free execution of your individual application.

Please read these operating instructions before putting your product into operation for the first time. If you have any questions or suggestions, please feel free to contact info@pfeiffer-vacuum.de.

Further operating instructions from Pfeiffer Vacuum can be found in the [Download Center](#) on our website.

Disclaimer of liability

These operating instructions describe all models and variants of your product. Note that your product may not be equipped with all features described in this document. Pfeiffer Vacuum constantly adapts its products to the latest state of the art without prior notice. Please take into account that online operating instructions can deviate from the printed operating instructions supplied with your product.

Furthermore, Pfeiffer Vacuum assumes no responsibility or liability for damage resulting from the use of the product that contradicts its proper use or is explicitly defined as foreseeable misuse.

Copyright

This document is the intellectual property of Pfeiffer Vacuum and all contents of this document are protected by copyright. They may not be copied, altered, reproduced or published without the prior written permission of Pfeiffer Vacuum.

We reserve the right to make changes to the technical data and information in this document.

Table of contents

1	About this manual	7
1.1	Validity	7
	1.1.1 Applicable documents	7
	1.1.2 Variants	7
1.2	Target group	7
1.3	Conventions	7
	1.3.1 Instructions in the text	7
	1.3.2 Pictographs	8
	1.3.3 Stickers on the product	8
	1.3.4 Abbreviations	9
1.4	Trademark proof	9
2	Safety	10
2.1	General safety information	10
2.2	Safety instructions	10
2.3	Safety precautions	14
2.4	Product usage limits	15
2.5	Proper use	15
2.6	Foreseeable improper use	15
2.7	Personnel qualification	16
	2.7.1 Ensuring personnel qualification	16
	2.7.2 Personnel qualification for maintenance and repair	16
3	Product description	17
3.1	Function	17
	3.1.1 Operating fluid	18
	3.1.2 Cooling	18
	3.1.3 Gas ballast system	18
	3.1.4 Operating fluid return via the float valve	18
3.2	Identifying the product	19
3.3	Product features	19
3.4	Scope of delivery	19
4	Transportation and Storage	20
4.1	Transporting the vacuum pump	20
4.2	Storing the vacuum pump	21
5	Installation	22
5.1	Installing the vacuum pump	22
5.2	Connecting the vacuum side	22
5.3	Connecting the exhaust side	23
5.4	Filling the operating fluid	24
5.5	Establishing mains connection	25
	5.5.1 Connect three phase motor with 6-pin terminal board	26
	5.5.2 Connect three phase motor with 9-pin terminal board	27
	5.5.3 Checking the direction of rotation	27
	5.5.4 Setting the motor protection switch	27
	5.5.5 Frequency inverter for vacuum pumps with 3-phase motor	28
	5.5.6 Connecting the PTC thermistor tripping unit	29
6	Operation	30
6.1	Putting the vacuum pump into operation	30
6.2	Switching on the vacuum pump	30
6.3	Operating the rotary vane pump with gas ballast	31
6.4	Operating the rotary vane pump with manual gas ballast valve	32
6.5	Refilling operating fluid	33
6.6	Switching off the vacuum pump	33

7	Maintenance	35
7.1	Maintenance instructions	35
7.2	Checklist for inspection and maintenance	36
7.3	Changing the operating fluid	37
7.3.1	Determine degree of aging of P3 operating fluid	37
7.3.2	Changing the operating fluid	38
7.3.3	Rinsing and cleaning the rotary vane vacuum pump	39
7.3.4	Changing the operating fluid filter	39
7.4	Change the exhaust filter in the operating fluid separator	40
7.4.1	Dismantling the exhaust filters	41
7.4.2	Mounting the exhaust filters	42
7.5	Cleaning the gas ballast filter	43
7.6	Cleaning the operating fluid return line	43
7.7	Cleaning the intake strainer	45
8	Decommissioning	47
8.1	Shutting down for longer periods	47
8.2	Recommissioning	47
9	Recycling and disposal	48
9.1	General disposal information	48
9.2	Dispose of rotary vane pump	48
10	Malfunctions	49
11	Service solutions by Pfeiffer Vacuum	51
12	Spare parts	53
12.1	Operating fluids – Maintenance level 1	53
12.2	Maintenance kit – maintenance level 1	53
12.3	Overhaul kit – maintenance level 3	53
12.4	Set of seals	53
12.5	Set of vanes	53
12.6	Ordering spare parts packages	53
13	Accessories	55
13.1	Accessory information	55
13.2	Ordering accessories	55
14	Technical data and dimensions	57
14.1	General	57
14.2	Technical data	57
14.3	Dimensions	59
	Declaration of conformity	61

List of tables

Tbl. 1:	Stickers on the product	8
Tbl. 2:	Abbreviations used in this document	9
Tbl. 3:	Product usage limits	15
Tbl. 4:	Features of the rotary vane pumps	19
Tbl. 5:	Motor protection switch setting values for Hena 61 global motor	28
Tbl. 6:	Motor protection switch setting values for Hena 61 Asian motor	28
Tbl. 7:	Motor protection switch setting values for Hena 101 global motor	28
Tbl. 8:	Motor protection switch setting values for Hena 101 Asian motor	28
Tbl. 9:	Maintenance intervals	36
Tbl. 10:	Troubleshooting for rotary vane pumps	50
Tbl. 11:	Consumables	53
Tbl. 12:	Spare parts packages	54
Tbl. 13:	Accessories for Hena 61 Hena 101	56
Tbl. 14:	Conversion table: Pressure units	57
Tbl. 15:	Conversion table: Units for gas throughput	57
Tbl. 16:	Technical data Hena 61	58
Tbl. 17:	Technical data Hena 101	59

List of figures

Fig. 2:	Position of the stickers on the product	8
Fig. 3:	Operating principle	17
Fig. 4:	Structure of the rotary vane pump	18
Fig. 5:	Transporting the vacuum pump	20
Fig. 6:	Minimum distances to the lateral limitations, top view	22
Fig. 7:	Filling the operating fluid	25
Fig. 8:	Delta connection	26
Fig. 9:	Star circuit	26
Fig. 10:	Terminal board for low voltage	27
Fig. 11:	Motor winding and terminal board for high voltage	27
Fig. 12:	Connection example with PTC thermistor tripping unit	29
Fig. 13:	Operating the vacuum pump with gas ballast system	32
Fig. 14:	Operating the rotary vane pump with manual gas ballast valve	32
Fig. 15:	Refilling operating fluid	33
Fig. 16:	Draining the operating fluid	39
Fig. 17:	Change operating fluid filter	40
Fig. 18:	Dismantling the exhaust filters	42
Fig. 19:	Cleaning the gas ballast filter	43
Fig. 20:	Operating fluid return with float valve	44
Fig. 21:	Dismantling / assembling the intake strainer	45
Fig. 22:	Dimensions Hena 61	59
Fig. 23:	Dimensions Hena 101	60

1 About this manual



IMPORTANT

Read carefully before use.
Keep the manual for future consultation.

1.1 Validity

This operating instructions is a customer document of Pfeiffer Vacuum. The operating instructions describe the functions of the named product and provide the most important information for the safe use of the device. The description is written in accordance with the valid directives. The information in this operating instructions refers to the product's current development status. The document shall remain valid provided that the customer does not make any changes to the product.

1.1.1 Applicable documents

Document	Number
Declaration of conformity	A component of these instructions

You can find this document in the [Pfeiffer Vacuum Download Center](#).

1.1.2 Variants

These instructions apply to HenaLine vacuum pumps.

Pump type	Pump version
Hena 61	Standard version of rotary vane pump
Hena 101	Standard version of rotary vane pump

1.2 Target group

This operating instructions is intended for persons who

- transport,
- installation,
- operate,
- decommissioning,
- servicing and cleaning,
- storage or disposal.

The work described in this document may only be carried out by persons who have appropriate professional qualifications (experts).

1.3 Conventions

1.3.1 Instructions in the text

Usage instructions in the document follow a general structure that is complete in itself. The required action is indicated by an individual step or multi-part action steps.

Individual action step

A horizontal, solid triangle indicates the only step in an action.

- ▶ This is an individual action step.





Sequence of multi-part action steps

The numerical list indicates an action with multiple necessary steps.

1. Step 1
2. Step 2
3. ...





1.3.2 Pictographs

The pictographs used in the document indicate useful information.

-  Note
-  Tip
-  true
-  false

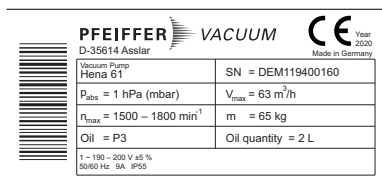
1.3.3 Stickers on the product

This section describes all the stickers on the product along with their meaning.

 <p>PFEIFFER VACUUM Year 2020 Made in Germany Vacuum Pump Hena 61 SN = DEM119400160 $P_{abs} = 1 \text{ hPa (mbar)}$ $V_{max} = 63 \text{ m}^3/\text{h}$ $n_{max} = 1500 - 1800 \text{ min}^{-1}$ $m = 65 \text{ kg}$ Oil = P3 Oil quantity = 2 L 1 - 190 - 200 V ±5% 50/60 Hz 9A IP55</p>	<p>Rating plate (example) Rating plate of the rotary vane pump Motor rating plate (not shown)</p>
	<p>Warning hot surface This sticker warns of injuries caused by high temperatures as a result of contact without safeguards during operation.</p>
	<p>Electrical voltage warning The sticker warns of the risk of electric shock when working with the housing open.</p>
	<p>No stepping on surface This sticker prohibits the use of the vacuum pump as a climbing aid.</p>
	<p>Arrow indicating direction of rotation The direction of rotation arrow indicates the direction of rotation of the motor.</p>

Tbl. 1: Stickers on the product

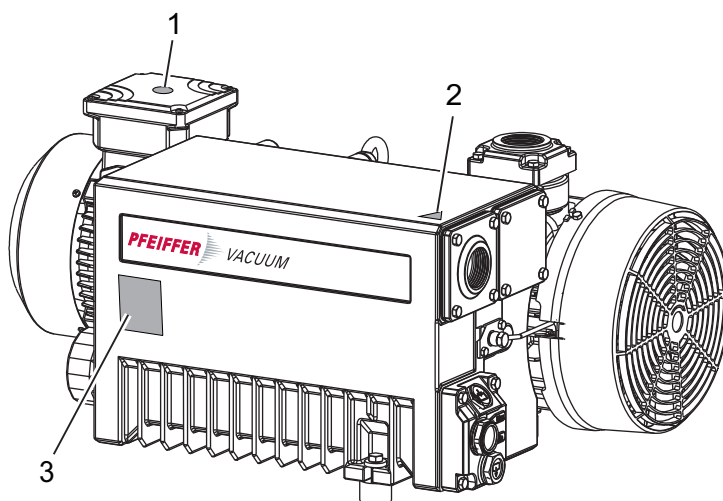

Fig. 2: Position of the stickers on the product

- 1 Operating instructions note
- 2 Hot surface warning sign
- 3 Rating plate of the rotary vane pump

1.3.4 Abbreviations

Abbreviation	Meaning in this document
OI	Operating instructions
N.N.	Mean sea level
PE	Earthed conductor (protective earth)
WAF	Width across flats
RSSR	Radial shaft seal ring

Tbl. 2: Abbreviations used in this document

1.4 Trademark proof

- Loctite® is a trademark of HENKEL IP & HOLDING GMBH.

2 Safety

2.1 General safety information

The following 4 risk levels and 1 information level are taken into account in this document.

⚠ DANGER
<p>Immediately pending danger</p> <p>Indicates an immediately pending danger that will result in death or serious injury if not observed.</p> <ul style="list-style-type: none"> ▶ Instructions to avoid the danger situation

⚠ WARNING
<p>Potential pending danger</p> <p>Indicates a pending danger that could result in death or serious injury if not observed.</p> <ul style="list-style-type: none"> ▶ Instructions to avoid the danger situation

⚠ CAUTION
<p>Potential pending danger</p> <p>Indicates a pending danger that could result in minor injuries if not observed.</p> <ul style="list-style-type: none"> ▶ Instructions to avoid the danger situation

NOTICE
<p>Danger of damage to property</p> <p>Is used to highlight actions that are not associated with personal injury.</p> <ul style="list-style-type: none"> ▶ Instructions to avoid damage to property

i	<p>Notes, tips or examples indicate important information about the product or about this document.</p>
----------	---

2.2 Safety instructions

All safety instructions in this document are based on the results of the risk assessment carried out in accordance with Machinery Directive 2006/42/EC Annex I and DIN EN ISO 12100 Section 5. Where applicable, all life cycle phases of the product were taken into account.

Risks during transport

⚠ WARNING
<p>Risk of serious injury from swinging, toppling or falling objects</p> <p>During transport, there is a risk of crushing and impact on swinging, toppling or falling objects. There is a risk of injuries to limbs, up to and including bone fractures and head injuries.</p> <ul style="list-style-type: none"> ▶ Secure the danger zone if necessary. ▶ Pay attention to the center of gravity of the load during transport. ▶ Ensure even movements and moderate speeds. ▶ Observe safe handling of the transport devices. ▶ Avoid sloping attachment aids. ▶ Never stack products. ▶ Wear protective equipment, e.g. safety shoes.

Risks during installation

⚠ DANGER**Danger to life from electric shock**

Touching exposed and voltage-bearing elements causes an electric shock. Improper connection of the mains supply leads to the risk of touchable live housing parts. There is a risk to life.

- ▶ Before the installation, check that the connection leads are voltage-free.
- ▶ Make sure that electrical installations are only carried out by qualified electricians.
- ▶ Provide adequate grounding for the device.
- ▶ After connection work, carry out an earthed conductor check.

⚠ WARNING**Danger of poisoning due to toxic process media escaping from the exhaust pipe**

During operation with no exhaust line, the vacuum pump allows exhaust gases and vapors to escape freely into the air. There is a risk of injury and fatality due to poisoning in processes with toxic process media.

- ▶ Observe the pertinent regulations for handling toxic process media.
- ▶ Safely purge toxic process media via an exhaust line.
- ▶ Use appropriate filter equipment to separate toxic process media.

⚠ WARNING**Tilting danger! Serious injury due to tilting of the product**

There is a danger of the vacuum pump not attached tipping over due to changes in the center of gravity or incorrect loading. Serious injuries due to trapping or crushing of limbs, e.g. feet, are the result.

- ▶ Do not use the vacuum pump as a climbing aid.
- ▶ Do not exert any force on the product.
- ▶ Ensure that the product has a safe centre of gravity, when mounting components.
- ▶ Wear protective equipment, e.g. protective shoes

⚠ CAUTION**Danger of injury from moving parts**

After a power failure or a standstill as a result of overheating, the motor restarts automatically. There is a risk of injury to fingers and hands if they enter the operating range of rotating parts.

- ▶ Safely disconnect motor from the mains.
- ▶ Secure the motor against reactivation.
- ▶ Dismantle the vacuum pump for inspection, away from the system if necessary.

Risks during operation

⚠ WARNING**Danger of poisoning due to toxic process media escaping from the exhaust pipe**

During operation with no exhaust line, the vacuum pump allows exhaust gases and vapors to escape freely into the air. There is a risk of injury and fatality due to poisoning in processes with toxic process media.

- ▶ Observe the pertinent regulations for handling toxic process media.
- ▶ Safely purge toxic process media via an exhaust line.
- ▶ Use appropriate filter equipment to separate toxic process media.

⚠ WARNING**Risk of burns from ejected hot oil mist**

During operation, hot pressurized oil mist escapes from the operating fluid separator.

- ▶ Only operate the vacuum pump with the filler screw securely fitted.
- ▶ Open the locking screws on the separator only while the vacuum pump is switched off.

⚠ WARNING

Tilting danger! Serious injury due to tilting of the product

There is a danger of the vacuum pump not attached tipping over due to changes in the center of gravity or incorrect loading. Serious injuries due to trapping or crushing of limbs, e.g. feet, are the result.

- ▶ Do not use the vacuum pump as a climbing aid.
- ▶ Do not exert any force on the product.
- ▶ Ensure that the product has a safe centre of gravity, when mounting components.
- ▶ Wear protective equipment , e.g. protective shoes

⚠ CAUTION

Risk of injury from entrapment of body parts

After a power failure or a standstill as a result of overheating, the motor restarts automatically. A risk exists of minor injury to fingers and hands (e.g., hematoma), from direct contact with the vacuum flange.

- ▶ Maintain sufficient distance to the vacuum flange during all work.
- ▶ Safely disconnect motor from the mains.
- ▶ Secure the motor against re-start.

⚠ CAUTION

Danger of injury from bursting as a result of high pressure in the exhaust line

Faulty or inadequate exhaust pipes lead to dangerous situations, e.g. increased exhaust pressure. There is a danger of bursting. Injuries caused by flying fragments, the escaping of high pressure, and damage to the unit cannot be excluded.

- ▶ Route the exhaust line without shut-off units.
- ▶ Observe the permissible pressures and pressure differentials for the product.
- ▶ Check the function of the exhaust line on a regular basis.

⚠ CAUTION

Danger of burns on hot surfaces

Depending on the operating and ambient conditions, the surface temperature of the vacuum pump can increase to above 70 °C.

- ▶ Provide suitable touch protection.

Risks during maintenance, decommissioning and malfunctions

⚠ WARNING

Health hazard through poisoning from toxic contaminated components or devices

Toxic process media result in contamination of devices or parts of them. During maintenance work, there is a risk to health from contact with these poisonous substances. Illegal disposal of toxic substances causes environmental damage.

- ▶ Take suitable safety precautions and prevent health hazards or environmental pollution by toxic process media.
- ▶ Decontaminate affected parts before carrying out maintenance work.
- ▶ Wear protective equipment.

⚠ WARNING

Danger to life from electric shock in the event of a fault

In the event of a fault, devices connected to the mains may be live. There is a danger to life from electric shock when making contact with live components.

- ▶ Always keep the mains connection freely accessible so you can disconnect it at any time.

⚠ WARNING**Health hazard and risk of environmental damage from toxic contaminated operating fluid**

Toxic process media can cause operating fluid contamination. When changing the operating fluid, there is a health hazard due to contact with poisonous substances. Illegal disposal of toxic substances causes environmental damage.

- ▶ Wear suitable personal protective equipment when handling these media.
- ▶ Dispose of the operating fluid according to locally applicable regulations.

⚠ WARNING**Health hazard through poisoning from toxic contaminated components or devices**

Toxic process media result in contamination of devices or parts of them. During maintenance work, there is a risk to health from contact with these poisonous substances. Illegal disposal of toxic substances causes environmental damage.

- ▶ Take suitable safety precautions and prevent health hazards or environmental pollution by toxic process media.
- ▶ Decontaminate affected parts before carrying out maintenance work.
- ▶ Wear protective equipment.

⚠ WARNING**Tilting danger! Serious injury due to tilting of the product**

There is a danger of the vacuum pump not attached tipping over due to changes in the center of gravity or incorrect loading. Serious injuries due to trapping or crushing of limbs, e.g. feet, are the result.

- ▶ Do not use the vacuum pump as a climbing aid.
- ▶ Do not exert any force on the product.
- ▶ Ensure that the product has a safe centre of gravity, when mounting components.
- ▶ Wear protective equipment, e.g. protective shoes

⚠ CAUTION**Risk of injury from entrapment of body parts**

After a power failure or a standstill as a result of overheating, the motor restarts automatically. A risk exists of minor injury to fingers and hands (e.g., hematoma), from direct contact with the vacuum flange.

- ▶ Maintain sufficient distance to the vacuum flange during all work.
- ▶ Safely disconnect motor from the mains.
- ▶ Secure the motor against re-start.

⚠ CAUTION**Scalding from hot operating fluid**

Danger of burns when draining operating fluid if it comes into contact with the skin.

- ▶ Wear protective equipment.
- ▶ Use a suitable collection vessel.

⚠ CAUTION**Danger of burns on hot surfaces**

In the event of a fault, the surface temperature of the vacuum pump can increase to above 105 °C.

- ▶ Allow the vacuum pump to cool down before carrying out any work.
- ▶ Wear personal protective equipment if necessary.

⚠ CAUTION

Danger of injury from moving parts

After a power failure or a standstill as a result of overheating, the motor restarts automatically. There is a risk of injury to fingers and hands if they enter the operating range of rotating parts.

- ▶ Safely disconnect motor from the mains.
- ▶ Secure the motor against reactivation.
- ▶ Dismantle the vacuum pump for inspection, away from the system if necessary.

Risks during disposal

⚠ WARNING

Health hazard through poisoning from toxic contaminated components or devices

Toxic process media result in contamination of devices or parts of them. During maintenance work, there is a risk to health from contact with these poisonous substances. Illegal disposal of toxic substances causes environmental damage.

- ▶ Take suitable safety precautions and prevent health hazards or environmental pollution by toxic process media.
- ▶ Decontaminate affected parts before carrying out maintenance work.
- ▶ Wear protective equipment.

2.3 Safety precautions

i

Duty to provide information on potential dangers

The product holder or user is obliged to make all operating personnel aware of dangers posed by this product.

Every person who is involved in the installation, operation or maintenance of the product must read, understand and adhere to the safety-related parts of this document.

i

Infringement of conformity due to modifications to the product

The Declaration of Conformity from the manufacturer is no longer valid if the operator changes the original product or installs additional equipment.

- Following the installation into a system, the operator is required to check and re-evaluate the conformity of the overall system in the context of the relevant European Directives, before commissioning that system.

General safety precautions when handling the product

- ▶ Observe all applicable safety and accident prevention regulations.
- ▶ Check that all safety measures are observed at regular intervals.
- ▶ Do not expose body parts to the vacuum.
- ▶ Always ensure a secure connection to the earthed conductor (PE).
- ▶ Never disconnect plug connections during operation.
- ▶ Observe the above shutdown procedures.
- ▶ Keep lines and cables away from hot surfaces (> 70 °C).
- ▶ Never fill or operate the unit with cleaning agents or cleaning agent residues.
- ▶ Do not carry out your own conversions or modifications on the unit.
- ▶ Observe the unit protection class prior to installation or operation in other environments.
- ▶ Provide suitable touch protection, if the surface temperature exceeds 70 °C.

2.4 Product usage limits

Parameter	Hena 61	Hena 101
Installation location	<ul style="list-style-type: none"> ● Indoors, protected against: <ul style="list-style-type: none"> – dust deposits – falling objects – fire-fighting water ● Outdoors, protected against: <ul style="list-style-type: none"> – falling objects – direct influence of weather such as rain, splash water, strong drafts and sunlight – fire-fighting water – lightning strike 	
Installation altitude	max. 1000 m above sea level At installation heights > 1000 m above sea level, the rated power of the motor must be reduced or the ambient temperature limited due to increased heating of the vacuum pump.	
Orientation	horizontal	
permissible angle of inclination	±1°	
Pumped medium intake temperature, max.	+40 °C	
Ambient temperature with mineral-based operating fluids (P3)	5 °C to 35 °C	
Ambient temperature with synthetic-based operating fluids (D1)	5 °C to 40 °C	
Relative air humidity	max. 85%	
Permissible operating pressure range during continuous operation	< 800 hPa	
Exhaust pressure	Atmospheric pressure	

Tbl. 3: Product usage limits

2.5 Proper use

- ▶ Use the vacuum pump for vacuum generation only.
- ▶ When pumping media with an oxygen concentration level of $\geq 21\%$, only use perfluorinated, synthetic oils (YLC 250 B, A113) as operating fluid.
- ▶ Adhere to the installation, commissioning, operating, and maintenance instructions.
- ▶ Do not use any accessory parts other than those recommended by Pfeiffer Vacuum.

2.6 Foreseeable improper use

Improper use of the product invalidates all warranty and liability claims. Any use that is counter to the purpose of the product, whether intentional or unintentional, is regarded as misuse, in particular:

- Pumping of corrosive media
- Pumping radioactive media
- Pumping of gases that introduce an ignition source to the suction chamber
- Pumping of gases that contain impurities such as particles, dust, or condensate
- Pumping of explosive media
- Pumping of media with a propensity to sublimation
- Pumping of fluids
- Use of the vacuum pump in potentially explosive atmospheres
- Use of the vacuum pump outside the specified area of application
- Use for pressure generation
- Use in strong electrical, magnetic, or electromagnetic fields
- Connection to vacuum pumps or equipment which are not suitable for this purpose according to their operating instructions

- Connection to devices with exposed live parts
- Use of accessories or spare parts not listed in these operating instructions
- Use of operating fluids other than those specified by Pfeiffer Vacuum
- Use of D1 or mineral oil as operating fluid with an oxygen concentration level of > 21 %. Mineral oils are combustible and ignite in high temperatures and when they come into contact with pure oxygen. This oils oxidize heavily and thus lose their lubricating capacity.

2.7 Personnel qualification

The work described in this document may only be carried out by persons who have appropriate professional qualifications and the necessary experience.

Training people

1. Train the technical personnel on the product.
2. Only let personnel to be trained work with and on the product when under the supervision of trained personnel.
3. Only allow trained technical personnel to work with the product.
4. Before starting work, make sure that the commissioned personnel have read and understood these operating instructions and all applicable documents, in particular the safety, maintenance and repair information.

2.7.1 Ensuring personnel qualification

Specialist for mechanical work

Only a trained specialist may carry out mechanical work. Within the meaning of this document, specialists are people responsible for construction, mechanical installation, troubleshooting, and maintenance of the product, and who have the following qualifications:

- Qualification in the mechanical field in accordance with nationally applicable regulations
- Knowledge of this documentation

Specialist for electrical engineering work

Only a trained electrician may carry out electrical engineering work. Within the meaning of this document, electricians are people responsible for electrical installation, commissioning, troubleshooting, and maintenance of the product, and who have the following qualifications:

- Qualification in the electrical engineering field in accordance with nationally applicable regulations
- Knowledge of this documentation

In addition, these individuals must be familiar with applicable safety regulations and laws, as well as the other standards, guidelines, and laws referred to in this documentation. The above individuals must have expressly granted operational authorization, to commission, program, configure, mark, and earth devices, systems, and circuits in accordance with safety technology standards.

Trained individuals

Only adequately trained individuals may carry out all works in other transport, storage, operation, and disposal fields. Such training must ensure that individuals are capable of carrying out the required activities and work steps safely and properly.

2.7.2 Personnel qualification for maintenance and repair

Adequately trained individuals are:

- **Maintenance level 1**
 - Customer with technical education
 - Pfeiffer Vacuum service technician
- **Maintenance level 3**
 - Pfeiffer Vacuum service technician

3 Product description

3.1 Function

The rotary vane pumps of the HenaLine are single-stage, oil-sealed rotary positive displacement pumps with air cooling and circulatory lubrication. A non-return valve in the vacuum connection closes the intake line automatically when the rotary vane pump is switched off and prevents an operating fluid return flow. The integrated oil mist filter cleans the conveyed gas and prevents the operating fluid mist from being emitted at the exhaust. The operating fluid collected in the separator is supplied back to the rotary vane pump. A filter is also installed on the operating fluid separator for cleaning the operating fluid.

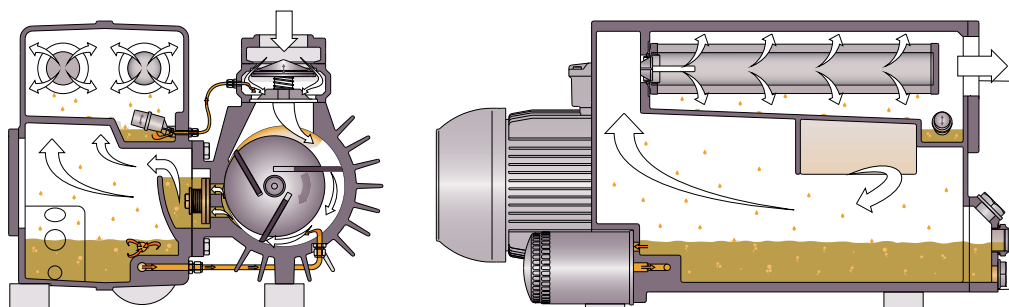

Fig. 3: Operating principle

The rotary vane pump requires operating fluid for sealing the gap, for lubrication and for cooling. The operating fluid reservoir is on the pressure side of the vacuum pump on the floor of the operating fluid separator. The pressure differential between the pressure side and suction side automatically causes operating fluid to be sucked in over the supply lines from the operating fluid separator and injected into the pumping system. The incoming operating fluid, together with the incoming gas, is pumped through the rotary vane pump and exhausted into the operating fluid separator as oil mist. Operating fluid that is separated at the exhaust filters collects in the upper part of the operating fluid separator and is returned via an operating fluid return line directly to the intake side. The rotary vane pump is cooled by heat radiation from the surface of the vacuum pump, the air flow of the two fans and the pumped gas.

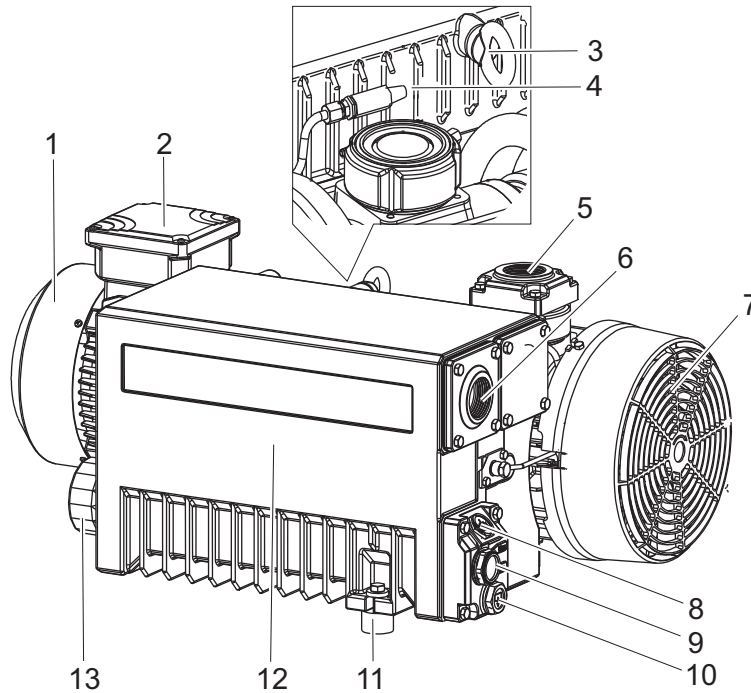

Fig. 4: Structure of the rotary vane pump

- | | |
|---|------------------------------------|
| 1 Motor | 8 Filler screw for operating fluid |
| 2 Motor terminal box | 9 Sight glass |
| 3 Crane lug | 10 Drain screw |
| 4 Gas ballast filter | 11 Rubber-metal bumper |
| 5 Vacuum connection | 12 Operating fluid separator |
| 6 Exhaust connection | 13 Operating fluid filter |
| 7 Axial fan with oil/air heat exchanger | |

3.1.1 Operating fluid

The pump oil, also known as operating fluid, fulfills various tasks in a rotary vane pump:

- lubrication of all moving parts
- filling part of the dead volume under the exhaust valve
- sealing the gap between the intake and exhaust channel, and between the vanes and the working chamber
- ensuring an optimal temperature balance through heat transfer

3.1.2 Cooling

The rotary vane pump is cooled by thermal radiation from its surface, the air flow of the two fans and the pumped gas.

3.1.3 Gas ballast system

The gas ballast system supplies air to the working chamber of the rotary vane pump periodically at the beginning of the compression phase. When pumping down vapors, this air prevents condensation within certain limits in the rotary vane pump. The gas ballast valve affects the final pressure of the rotary vane pump.

3.1.4 Operating fluid return via the float valve



Function of the operating fluid return

The operating fluid return functions only at an operating pressure of < 800 hPa.

The rotary vane pump is equipped with an operating fluid return as standard. If the operating fluid collected in the operating fluid separator reaches a certain level, a float valve opens and the ejected operating fluid is returned to the intake port of the vacuum pump.

3.2 Identifying the product

- ▶ To ensure clear identification of the product when communicating with Pfeiffer Vacuum, always keep all of the information on the rating plate to hand.
- ▶ Observe the motor-specific data on the motor rating plate attached separately.

3.3 Product features

Pump type	Characteristics
Hena 61	<ul style="list-style-type: none"> • Nominal pumping speed <ul style="list-style-type: none"> – 50 Hz: 63 m³/h – 60 Hz: 76 m³/h • Vacuum connection and gas outlet: G1 1/4" • Operating fluid return via the float valve • Gas ballast unit without shut-off valve
Hena 101	<ul style="list-style-type: none"> • Nominal pumping speed <ul style="list-style-type: none"> – 50 Hz: 100 m³/h – 60 Hz: 120 m³/h • Vacuum connection and gas outlet: G1 1/4" • Operating fluid return via the float valve • Gas ballast unit without shut-off valve

Tbl. 4: Features of the rotary vane pumps

3.4 Scope of delivery

- Rotary vane pump with motor
- Operating fluid
- Locking caps for vacuum and exhaust connection
- Operating instructions

4 Transportation and Storage

4.1 Transporting the vacuum pump

⚠ WARNING

Risk of serious injury from oscillating, toppling or falling objects

During transport, there is a risk of crushing and impact on oscillating, toppling or falling objects. There is a risk of injuries to limbs, up to and including bone fractures and head injuries.

- ▶ Secure the danger zone if necessary.
- ▶ Note the center of gravity of the load during transport.
- ▶ Do not lift the vacuum pump via the eye bolt on the motor.
- ▶ Ensure harmonious movements and moderate speeds.
- ▶ Observe safe handling of the transport devices.
- ▶ Avoid sloping attachment aids.
- ▶ Never stack products.
- ▶ Wear protective equipment, e.g. safety shoes.

NOTICE

Equipment damage from operating fluid leaking into the pumping system.

If the vacuum pump is tipped, the operating fluid will overflow into the pumping system, resulting in the vane breaking when the vacuum pump is switched on.

- ▶ Always transport the vacuum pump horizontally or without operating fluid filling.
- ▶ Fill in the operating fluid only at the final installation location.



Preparations for transport

Pfeiffer Vacuum recommends keeping the transport packaging and original protective cover.

General information regarding safe transport

1. Observe the weight specified on packaging.
2. Use transport equipment (e.g. fork lift truck or lift truck).
3. Where possible, always transport or ship the product in the original packaging.
4. Be mindful of transport damage.
5. Always place the product on an adequately sized, level surface.

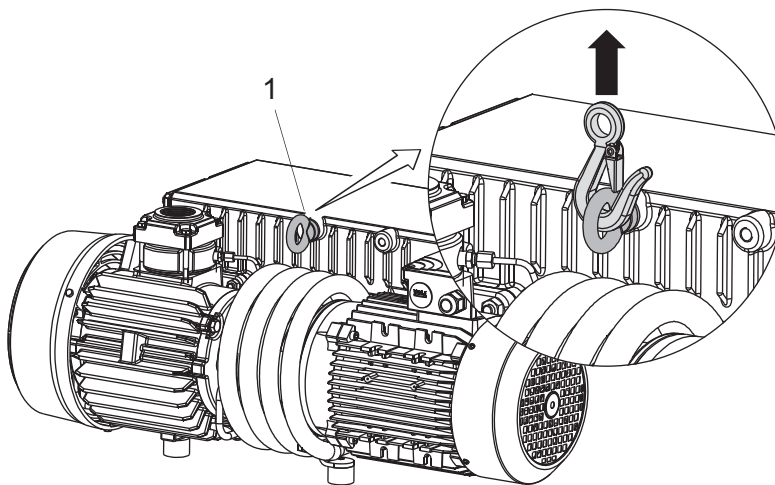

Fig. 5: Transporting the vacuum pump

1 Crane lug

Transporting the vacuum pump without its packaging

1. Unpack the vacuum pump.
2. Only remove the present protective cover immediately prior to installation.
3. For lifting, use the crane lug provided for this purpose.
4. Lift the vacuum pump out of the transport packaging.
5. Loosen and remove all parts from the original packaging.
6. Use another belt to lift the vacuum pump without motor and if accessories are mounted.

4.2 Storing the vacuum pump**Storage**

Pfeiffer Vacuum recommends storing the products in their original transport packaging.

Procedure

1. Seal the vacuum and exhaust connection.
2. Store the vacuum pump only in dry, dust-free rooms, within the specified ambient conditions.
3. In rooms with humid or aggressive atmospheres: Hermetically seal the vacuum pump together with a drying agent in a plastic bag.
4. Change the operating fluid if the storage period is longer than 2 years.

5 Installation

5.1 Installing the vacuum pump

⚠ WARNING

Tilting danger! Serious injury due to tilting of the product

There is a danger of the vacuum pump not attached tipping over due to changes in the center of gravity or incorrect loading. Serious injuries due to trapping or crushing of limbs, e.g. feet, are the result.

- ▶ Do not use the vacuum pump as a climbing aid.
- ▶ Do not exert any force on the product.
- ▶ Ensure that the product has a safe centre of gravity, when mounting components.
- ▶ Wear protective equipment, e.g. protective shoes

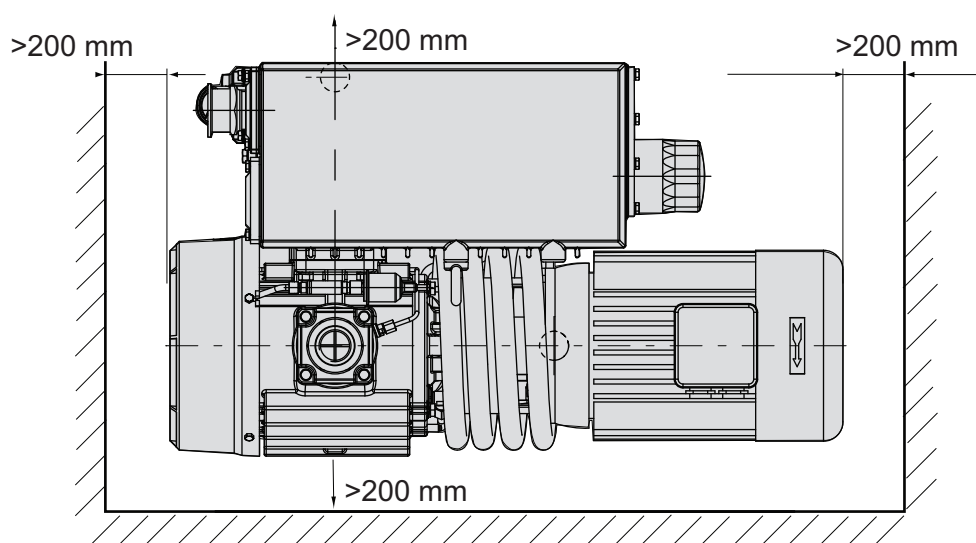

Fig. 6: Minimum distances to the lateral limitations, top view

Procedure

1. Place the vacuum pump on a flat, horizontal surface.
2. Observe the permissible angle of inclination of $\pm 1^\circ$.
3. The vacuum pump can be secured with stationary installation on the base as required.
4. When installing the pump in a closed housing, ensure adequate air circulation.
5. Keep the sight glass visible and freely accessible.
6. Keep the voltage and frequency specifications on the motor rating plate visible and freely accessible.
7. Ensure that the connections remain freely accessible at all times.

5.2 Connecting the vacuum side

NOTICE

Property damage from contaminated gases

Pumping down gases that contain impurities (condensate, particles) damages the vacuum pump.

- ▶ Use suitable filters or separators from the Pfeiffer Vacuum range of accessories, to protect the vacuum pump.



Installation and operation of accessories

Pfeiffer Vacuum offers a series of special, compatible accessories for its rotary vane pumps.

- You can find information and ordering options for approved [accessories](#) online.
- Described accessories are not included in the shipment.

Required consumable material

- Screw lock, e.g. Loctite 245 or Loctite 577

Procedure

1. Remove the protective cover from the vacuum connection.
2. Establish the shortest possible pipeline between vacuum pump and vacuum chamber.
3. Choose a minimum diameter equal to the nominal diameter of the vacuum connection.
4. Clean the connection threads.
5. Seal the connection threads with screw lock.
6. Install the piping with pipe components and fasteners from the [Pfeiffer Vacuum Components Shop](#).
7. Support or suspend the piping to the vacuum pump so that no piping system forces act on the vacuum pump.
8. Use a screwing flange, separator or filter from the Pfeiffer Vacuum line of [accessories](#) if necessary.

5.3 Connecting the exhaust side

WARNING

Danger of poisoning due to toxic process media escaping from the exhaust pipe

During operation with no exhaust line, the vacuum pump allows exhaust gases and vapors to escape freely into the air. There is a risk of injury and fatality due to poisoning in processes with toxic process media.

- ▶ Observe the pertinent regulations for handling toxic process media.
- ▶ Safely purge toxic process media via an exhaust line.
- ▶ Use appropriate filter equipment to separate toxic process media.

CAUTION

Danger of injury from bursting as a result of high pressure in the exhaust line

Faulty or inadequate exhaust pipes lead to dangerous situations, e.g. increased exhaust pressure. There is a danger of bursting. Injuries caused by flying fragments, the escaping of high pressure, and damage to the unit cannot be excluded.

- ▶ Route the exhaust line without shut-off units.
- ▶ Observe the permissible pressures and pressure differentials for the product.
- ▶ Check the function of the exhaust line on a regular basis.



Installation and operation of accessories

Pfeiffer Vacuum offers a series of special, compatible accessories for its rotary vane pumps.

- You can find information and ordering options for approved [accessories](#) online.
- Described accessories are not included in the shipment.



Condensate separator

Pfeiffer Vacuum recommends installing a condensate separator, with condensate drain at the lowest point of the exhaust line.

Required consumable material

- Screw lock, e.g. Loctite 245 or Loctite 577

Procedure

1. Remove the protective cap from the exhaust connection.
2. Choose a minimum diameter equal to the nominal diameter of the exhaust connection.
3. Route the piping downwards from the vacuum pump, to prevent condensate return.
 - If an air trap is created in the system then a device for draining condensation water must be provided at the lowest point.
4. Clean the connection threads.
5. Seal the connection threads with screw lock.
6. Install the piping with pipe components and fasteners from the [Pfeiffer Vacuum Components Shop](#).
7. Support or suspend the piping to the vacuum pump so that no piping system forces act on the vacuum pump.

5.4 Filling the operating fluid

NOTICE

Risk of damage due to the use of non-approved operating fluid

Product-specific performance data are not achieved. All liability and warranty claims against Pfeiffer Vacuum are also excluded.

- ▶ Only use approved operating fluids.
- ▶ Only use other application-specific operating fluids after consultation with Pfeiffer Vacuum.

The type of operating fluid specified, as well as the filling quantity for the entire rotary vane pump, are shown on the rating plate. Only the operating fluid used during initial installation is permissible.

Approved operating fluid

- P3 (standard operating fluid)
- D1 for special applications (such as higher operating temperatures)

Read the operating fluid type on the rating plate

- ▶ Refer to the rating plate of the vacuum pump for type and quantity of intended operating fluid.

Required consumable material

- Operating fluid

Required tool

- Ring spanner **WAF 32**

Required aids

- Funnel (optional)

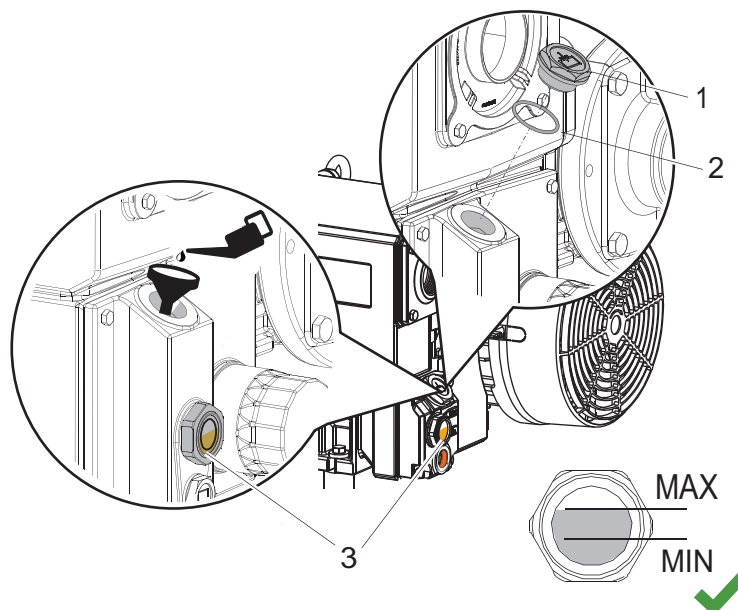

Fig. 7: Filling the operating fluid

- | | |
|----------------|---------------|
| 1 Filler screw | 3 Sight glass |
| 2 O-ring | |

Filling the operating fluid

1. Unscrew the filler screw.
2. Fill the operating fluid according to the sight glass.
 - The correct fill level is between the MIN/MAX markings or within the ring mark on the sight glass.
3. Screw in the filler screw.
 - Be careful with the O-ring.
4. Shut off the vacuum connection or the intake port valve, if fitted.
5. Start the vacuum pump.
6. Operate the vacuum pump for approx. 5 minutes.
7. Switch off the vacuum pump.
8. Wait approx. 1 minute until the operating fluid has accumulated in the operating fluid separator.
9. Check the fill level on the sight glass.
 - The correct fill level is between the MIN/MAX markings or within the ring mark on the sight glass.
10. If necessary, fill more operating fluid in case the fill level is incorrect.
11. Open the intake port valve, if fitted.

5.5 Establishing mains connection

⚠ DANGER

Danger to life from electric shock

Touching exposed and voltage-bearing elements causes an electric shock. Improper connection of the mains supply leads to the risk of touchable live housing parts. There is a risk to life.

- ▶ Before the installation, check that the connection leads are voltage-free.
- ▶ Make sure that electrical installations are only carried out by qualified electricians.
- ▶ Provide adequate grounding for the device.
- ▶ After connection work, carry out an earthed conductor check.

⚠ CAUTION

Danger of injury from moving parts

After a power failure or a standstill as a result of overheating, the motor restarts automatically. There is a risk of injury to fingers and hands if they enter the operating range of rotating parts.

- ▶ Safely disconnect motor from the mains.
- ▶ Secure the motor against reactivation.
- ▶ Dismantle the vacuum pump for inspection, away from the system if necessary.

NOTICE

Risk of damage from excess voltage

Incorrect or excessive mains voltage will destroy the motor.

- ▶ Always observe the motor rating plate specifications.
- ▶ Route the mains connection in accordance with locally applicable provisions.
- ▶ Always provide a suitable mains fuse to protect the motor and supply cable in the event of a fault.
 - Pfeiffer Vacuum recommends the circuit breaker type "K" with slow tripping characteristic.

NOTICE

Property damage from high starting torque

The specific load behavior of the vacuum pump requires direct on-line starting at full motor power. Engine damage occurs if a different starting circuit is used.

- ▶ Always start the motor directly.
- ▶ **Never** use a star-delta start-up circuit.

5.5.1 Connect three phase motor with 6-pin terminal board

There are 2 different circuit configurations:

- Delta connection for low voltage
- Star circuit for high voltage

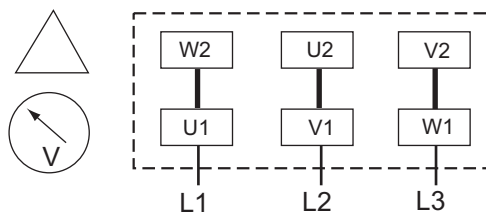

Fig. 8: Delta connection

The 3 wires are connected in series. Their connection points are connected to the mains. The voltage per phase is equal to the mains voltage, while the mains current is $\sqrt{3}$ times the phase current. The delta connection is marked with the Δ symbol. The voltage between the incoming mains supply lines is called mains voltage. The mains current is the current flowing in the incoming supply lines.

Connect the three phase motor with delta connection

- ▶ Connect the three phase motor according to the connection diagram.

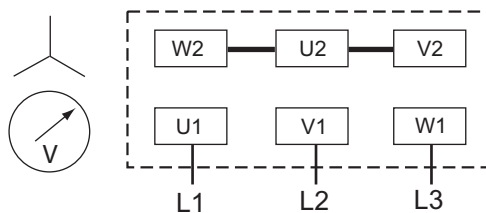

Fig. 9: Star circuit

The ends of the 3 phases are connected in the star point. The terminal voltage is $\sqrt{3}$ times the phase voltage, the mains current is equal to the phase current. The star circuit is marked with the Y symbol.

Connect the three phase motor with star circuit

- ▶ Connect the three phase motor according to the connection diagram.

5.5.2 Connect three phase motor with 9-pin terminal board

There are 2 different circuit configurations:

- Double star circuit for low voltage
- Star circuit for high voltage

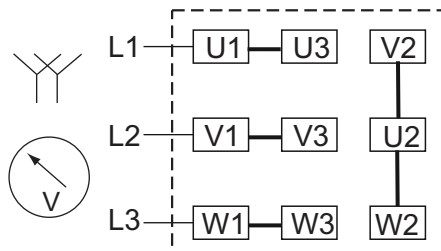

Fig. 10: Terminal board for low voltage

The parallel-switched winding strands are arranged in a star layout. The mains current is distributed to two coils in each case.

Connect the three phase motor with double star circuit

- ▶ Connect the three phase motor according to the connection diagram.

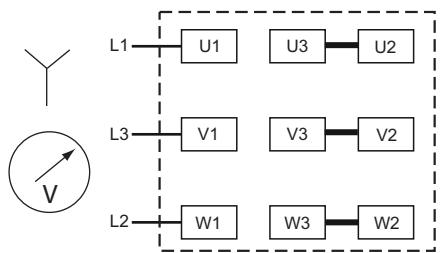

Fig. 11: Motor winding and terminal board for high voltage

The series-switched winding strands are arranged in a star layout. The mains voltage must be higher by a factor of 2, the mains current is halved compared to the double star circuit.

Connect the three phase motor with star circuit

- ▶ Connect the three phase motor according to the connection diagram.

5.5.3 Checking the direction of rotation

NOTICE
<p>Equipment damage from incorrect direction of rotation</p> <p>The direction of rotation must be checked on vacuum pumps with three phase motors. If the vacuum pump has an incorrect direction of rotation, damage may be caused to the pumping system after a short time.</p> <ul style="list-style-type: none"> ▶ Determine the intended direction of rotation based on the arrow sticker. ▶ Fill in the operating fluid only after that.

Procedure

1. Switch on the vacuum pump briefly (2 to 3 seconds).
 - The motor and motor fan must rotate counter-clockwise (see the arrow on the fan cover).
2. If the direction of rotation is incorrect, exchange the 2 phases on the connection cable.

5.5.4 Setting the motor protection switch

Motor protection switches are current-dependent protective devices for the drive motors. Motor protection switches with slow tripping characteristics are suitable.

An increase of 1.5 times the rated current over a 2 minute period is permissible for the drive motors (in accordance with EN 60034-1), without tripping the motor protection switch.

Procedure

1. Take the settings for the motor protection switch from the following table.
2. Take into consideration that certain operating conditions (for example, cold vacuum pump start) can cause short-term increases in current consumption.
3. Set the desired value on the motor protection switch.

Voltage [V]	Frequency [Hz]	Motor rating [kW]	I_N [A]	I_{max} [A]
190 – 200	50	2.0	8.2	61
380 – 400	50	2.0	4.1	31
208	60	2.4	8.9	70
220	60	2.4	8.4	66
230	60	2.4	8.2	64
440	60	2.4	4.2	33
460	60	2.4	4.1	32

Tbl. 5: Motor protection switch setting values for Hena 61 global motor

Voltage [V]	Frequency [Hz]	Motor rating [kW]	I_N [A]	I_{max} [A]
200	50	2.0	8.7	80
346	50	2.0	5.0	46
220	60	2.4	8.8	77
380	60	2.4	5.1	45

Tbl. 6: Motor protection switch setting values for Hena 61 Asian motor

Voltage [V]	Frequency [Hz]	Motor rating [kW]	I_N [A]	I_{max} [A]
190 – 200	50	2.7	12.0	99
380 – 400	50	2.7	6.0	50
208	60	3.4	13.2	107
220	60	3.4	13.0	106
230	60	3.4	12.8	104
440	60	3.4	6.5	53
460	60	3.4	6.4	52

Tbl. 7: Motor protection switch setting values for Hena 101 global motor

Voltage [V]	Frequency [Hz]	Motor rating [kW]	I_N [A]	I_{max} [A]
200	50	2.7	15.6	142
346	50	2.7	9.0	82
220	60	3.4	14.2	131
380	60	3.4	8.2	76

Tbl. 8: Motor protection switch setting values for Hena 101 Asian motor

5.5.5 Frequency inverter for vacuum pumps with 3-phase motor

Rotary vane pumps with variable rotation speed can be operated within a mains frequency range of 35 to 60 Hz. Start-up is ramped (maximum run-up time: 30 s). Shutdown can take place immediately.

5.5.6 Connecting the PTC thermistor tripping unit



Tripping units store the shut-down

Pfeiffer Vacuum recommends connecting motors with PTC in the stator winding to a PTC resistor tripping device for protection against overload.

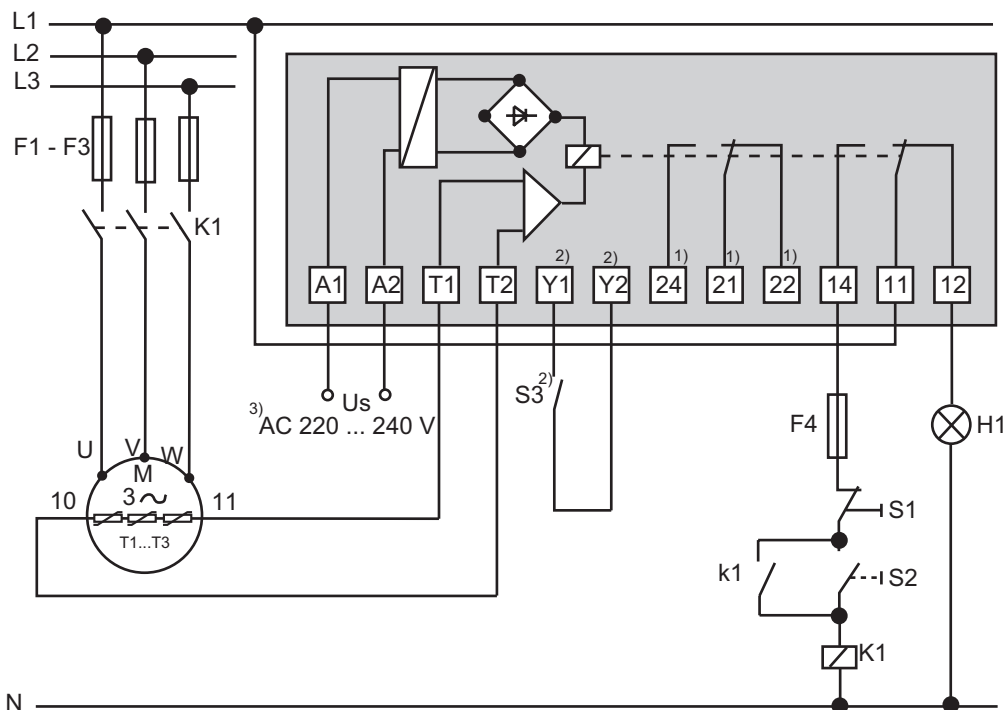

Fig. 12: Connection example with PTC thermistor tripping unit

U _s	Control voltage	T1 – T3	PTC resistor sensor
S ₁	OFF button	H1	Tripping indicator
S ₂	ON button	M	Motor, 3-phase
S ₃	RESET button	1)	For devices with two relay outputs only
K1	Contactor	2)	For MSR type (model) only
F1 – F4	Fuses	3)	Only for order no.: P 4768 052 FQ and P 4768 052 FE

Procedure

- ▶ After shut-down, switch the tripping unit back on manually via the installed RESET button or via the external RESET S3.
 - Switching on mains detected as automatic RESET.

6 Operation

6.1 Putting the vacuum pump into operation

WARNING

Danger of poisoning due to toxic process media escaping from the exhaust pipe

During operation with no exhaust line, the vacuum pump allows exhaust gases and vapors to escape freely into the air. There is a risk of injury and fatality due to poisoning in processes with toxic process media.

- ▶ Observe the pertinent regulations for handling toxic process media.
- ▶ Safely purge toxic process media via an exhaust line.
- ▶ Use appropriate filter equipment to separate toxic process media.

WARNING

Tilting danger! Serious injury due to tilting of the product

There is a danger of the vacuum pump not attached tipping over due to changes in the center of gravity or incorrect loading. Serious injuries due to trapping or crushing of limbs, e.g. feet, are the result.

- ▶ Do not use the vacuum pump as a climbing aid.
- ▶ Do not exert any force on the product.
- ▶ Ensure that the product has a safe centre of gravity, when mounting components.
- ▶ Wear protective equipment, e.g. protective shoes

CAUTION

Danger of injury from bursting as a result of high pressure in the exhaust line

Faulty or inadequate exhaust pipes lead to dangerous situations, e.g. increased exhaust pressure. There is a danger of bursting. Injuries caused by flying fragments, the escaping of high pressure, and damage to the unit cannot be excluded.

- ▶ Route the exhaust line without shut-off units.
- ▶ Observe the permissible pressures and pressure differentials for the product.
- ▶ Check the function of the exhaust line on a regular basis.

Before switching on

1. Check the operating fluid in the sight glass.
2. Compare the voltage and frequency specifications on the motor rating plate with the available mains voltage and frequency.
3. Protect the vacuum pump from sucking in contamination using suitable measures.
4. Check the operating fluid at regular intervals.
5. Check the exhaust connection for free passage (max. permissible pressure: atmospheric pressure).

6.2 Switching on the vacuum pump

WARNING

Risk of burns from ejected hot oil mist

During operation, hot pressurized oil mist escapes from the operating fluid separator.

- ▶ Only operate the vacuum pump with the filler screw securely fitted.
- ▶ Open the locking screws on the separator only while the vacuum pump is switched off.

⚠ CAUTION**Danger of burns on hot surfaces**

Depending on the operating and ambient conditions, the surface temperature of the vacuum pump can increase to above 70 °C.

- ▶ Provide suitable touch protection.

NOTICE**Risk of damage to the drive from increased motor current consumption**

At an intake pressure of approximately 300 hPa and under unfavorable operating conditions (such as for example exhaust side counterpressure), the power input exceeds the rated current.

- ▶ Limit the maximum power input of 1.5 times the rated current to max. 2 minutes (in accordance with EN 60034-1).

**Cycle operation**

Cycle operation with maximum 10 cycles per hour is possible.

Longer operating phases and short downtimes permit a functionally safe operating condition of the vacuum pump.

Operating Conditions

- You can switch on the vacuum pump in every pressure range, between atmospheric pressure and final pressure.
- The optimal operating condition of the vacuum pump is continuous operation.
- When pumping down dry gases, no special precautions are required.
- If the gas ballast system is permanently open, this limits the achievable final pressure of the vacuum pump.
- Low final pressures are possible with the gas ballast valve closed. To seal or control the gas ballast system, there are various accessories available.

Switching on the vacuum pump

1. If required, switch the vacuum pump on in each pressure range.
2. Shut off the vacuum connection.
3. Allow the vacuum pump to warm up prior to process start, with the vacuum connection closed, for approx. 30 minutes.

Inspect operating fluid level

1. Regularly check the operating fluid level while the vacuum pump is running and at operating temperature.
2. Make sure that the fill level is within the markings of the sight glass.
3. Check the operating fluid fill level daily during continuous operation, and every time the vacuum pump is switched on.

6.3 Operating the rotary vane pump with gas ballast

NOTICE**Risk of damage from condensation in vacuum pump**

During operation without gas ballast, condensation may form as a result of the vapor compatibility of the vacuum pump being exceeded.

- ▶ Pump condensable vapors only when the vacuum pump is warm and the gas ballast valve open.
- ▶ Allow the vacuum pump to run on after process end for another 30 minutes with the gas ballast valve open.
 - This cleans the operating fluid and protects the vacuum pump against corrosion.

The rotary vane pump has a gas ballast system through which air is permanently taken in. To achieve the lowest possible final pressure, a manual gas ballast valve (ball valve) can be retrofitted as a shut-off device.

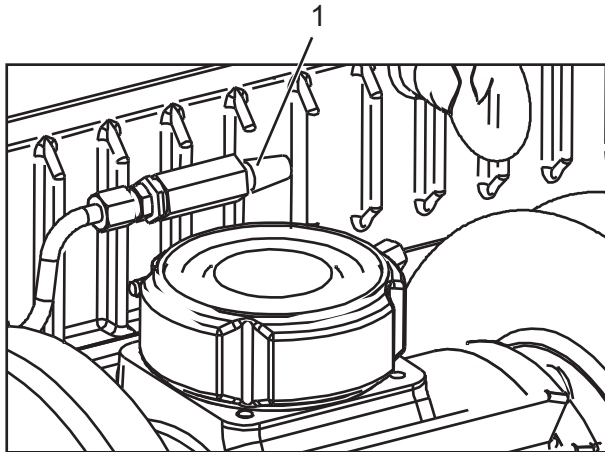

Fig. 13: Operating the vacuum pump with gas ballast system

1 Gas ballast filter

6.4 Operating the rotary vane pump with manual gas ballast valve



No intermediate settings possible

An intermediate setting between open/closed is not possible.

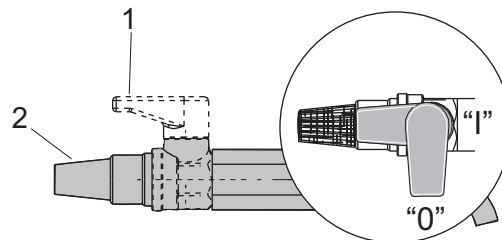

Fig. 14: Operating the rotary vane pump with manual gas ballast valve

1 Ball valve 2 Gas ballast filter

Prerequisite

- Manual gas ballast valve retrofitted
- Vacuum pump heated up for 30 minutes

Behavior with process gases with condensable vapors

- ▶ Operate the vacuum pump with gas ballast, i.e. with the gas ballast valve open.

Open gas ballast valve

- ▶ Turn the ball valve to position "1".

Close gas ballast valve

- ▶ Turn the ball valve to position "0".

After the process

- ▶ Operate the vacuum pump for a further 30 minutes.

6.5 Refilling operating fluid

Prerequisite

- Vacuum pump switched off

Required tool

- Ring spanner, **WAF 32**

Required consumable material

- Operating fluid

Required aids

- Funnel (optional)

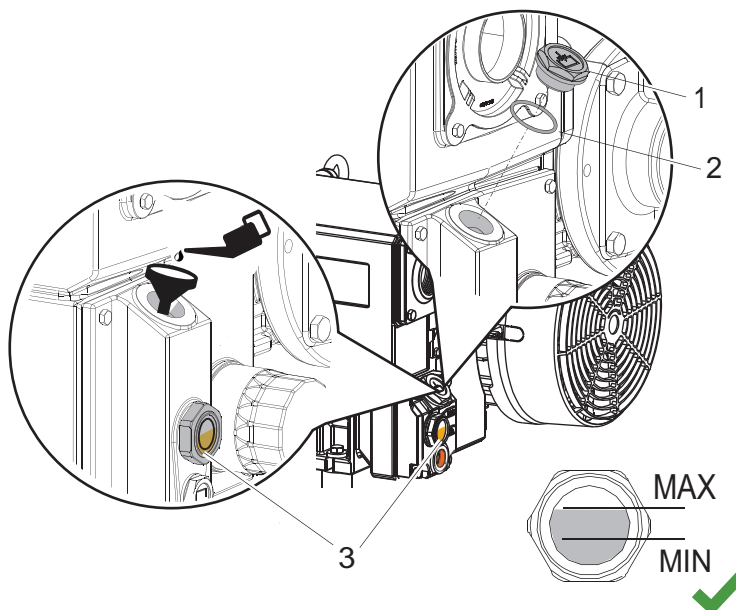

Fig. 15: Refilling operating fluid

- | | |
|----------------|---------------|
| 1 Filler screw | 3 Sight glass |
| 2 O-ring | |

Procedure

1. Unscrew the filler screw.
2. With the vacuum pump at operating temperature, refill with operating fluid up to the top marking before the minimum fill level is reached.
3. Screw in the filler screw again.
 - Be careful with the O-ring.

6.6 Switching off the vacuum pump

NOTICE

Contamination from operating fluid backflow

After the vacuum pump is switched off, there is a risk that the connected vacuum system can become contaminated by backflow. The safety valve on the vacuum pump is not suitable for longer-term sealing.

- ▶ Install an additional shut-off valve in the intake line.
- ▶ Shut off the intake line immediately after switching off the vacuum pump.

NOTICE

Contamination of the vacuum chamber from operating fluid backflow

After the vacuum pump is switched off, there is a risk that the connected vacuum system can become contaminated by backflow.

- ▶ Vent the vacuum chamber, regardless of its size, within 30 seconds.
- ▶ Shut off the intake line with an additional shut-off valve, after the vacuum pump is switched off during longer venting operations.

Rotary vane vacuum pumps of the HenaLine have an integrated non-return valve on the suction side. The non-return valve closes automatically when the vacuum pump is switched off, preventing the return flow of gas and processing materials into the intake line.

Procedure

1. If required, switch the vacuum pump off in each pressure range.
2. Isolate the control input or disconnect the electronic drive unit safely from the mains.
3. Install an additional shut-off valve in the intake line to ensure that the vacuum is maintained in the vacuum chamber.
4. Remove the mains cable and disconnect the vacuum pump from the power supply.

7 Maintenance

7.1 Maintenance instructions

WARNING

Health hazard through poisoning from toxic contaminated components or devices

Toxic process media result in contamination of devices or parts of them. During maintenance work, there is a risk to health from contact with these poisonous substances. Illegal disposal of toxic substances causes environmental damage.

- ▶ Take suitable safety precautions and prevent health hazards or environmental pollution by toxic process media.
- ▶ Decontaminate affected parts before carrying out maintenance work.
- ▶ Wear protective equipment.

WARNING

Tilting danger! Serious injury due to tilting of the product

There is a danger of the vacuum pump not attached tipping over due to changes in the center of gravity or incorrect loading. Serious injuries due to trapping or crushing of limbs, e.g. feet, are the result.

- ▶ Do not use the vacuum pump as a climbing aid.
- ▶ Do not exert any force on the product.
- ▶ Ensure that the product has a safe centre of gravity, when mounting components.
- ▶ Wear protective equipment, e.g. protective shoes

CAUTION

Danger of injury from moving parts

After a power failure or a standstill as a result of overheating, the motor restarts automatically. There is a risk of injury to fingers and hands if they enter the operating range of rotating parts.

- ▶ Safely disconnect motor from the mains.
- ▶ Secure the motor against reactivation.
- ▶ Dismantle the vacuum pump for inspection, away from the system if necessary.

CAUTION

Danger of burns on hot surfaces

Depending on the operating and ambient conditions, the surface temperature of the vacuum pump can increase to above 70 °C.

- ▶ Provide suitable touch protection.

NOTICE

Danger of property damage from improper maintenance

Unprofessional work on the vacuum pump will lead to damage for which Pfeiffer Vacuum accepts no liability.

- ▶ We recommend taking advantage of our service training offering.
- ▶ When ordering spare parts, specify the information on the nameplate.

The following section describes the tasks for cleaning and maintaining the vacuum pump. More advanced works are described in the service instructions.

Prerequisites

- Vacuum pump switched off
- Vacuum pump vented to atmospheric pressure
- Vacuum pump cooled

Preparing maintenance

- ▶ Safely disconnect the drive motor from the mains.
- ▶ Secure the motor against switching back on.
- ▶ For maintenance work, only dismantle the vacuum pump to the extend needed.
- ▶ Dispose of used operating fluid according to applicable regulations in each case.
- ▶ When using synthetic operating fluid, please observe the associated application instructions.
- ▶ Only clean the pump parts using industrial alcohol, isopropanol or similar media.

7.2 Checklist for inspection and maintenance



Notes on maintenance intervals

Depending on the process, the required maintenance intervals may be shorter than the reference values specified in the table.

- Consult with Pfeiffer Vacuum Service about shorter maintenance intervals for extreme loads or for specific processes.



Maintenance intervals

You can carry out the **inspection** yourself.

We recommend Pfeiffer Vacuum Service for carrying out maintenance work of **Maintenance Level 1** and **Maintenance Level 3** (revision). If the required intervals listed below are exceeded, or if maintenance work is carried out improperly, no warranty or liability claims are accepted on the part of Pfeiffer Vacuum. This also applies wherever parts other than original spare parts are used.

Action described in document	Inspection		Maintenance level 1 OI	Maintenance level 3	Required material
	daily	every 6 months	yearly	every 5 years	
Inspection					
<ul style="list-style-type: none"> • Check the operating fluid filling level • Check the vacuum pump for operating fluid leaks 	■				
<ul style="list-style-type: none"> • Clean the outside of the pump housing • If fitted, clean the gas ballast valve filter • If fitted, check and clean the air/oil heat exchanger 		■			
Maintenance Level 1 – operating fluid and filter change					
<ul style="list-style-type: none"> • Changing the operating fluid • Changing the operating fluid filter • Changing the exhaust filter 			■		<ul style="list-style-type: none"> • Operating fluid • Maintenance set level 1
Maintenance Level 3 – overhaul including changing all wear parts					
<ul style="list-style-type: none"> • Change the bearings, seals and valves • Vane change, optional 				■	Contact Pfeiffer Vacuum Service. <ul style="list-style-type: none"> • Set of vanes, optional • Overhaul kit

Tbl. 9: Maintenance intervals

7.3 Changing the operating fluid

WARNING

Health hazard and risk of environmental damage from toxic contaminated operating fluid

Toxic process media can cause operating fluid contamination. When changing the operating fluid, there is a health hazard due to contact with poisonous substances. Illegal disposal of toxic substances causes environmental damage.

- ▶ Wear suitable personal protective equipment when handling these media.
- ▶ Dispose of the operating fluid according to locally applicable regulations.

CAUTION

Scalding from hot operating fluid

Danger of burns when draining operating fluid if it comes into contact with the skin.

- ▶ Wear protective equipment.
- ▶ Use a suitable collection vessel.



Pfeiffer Vacuum recommends determining the precise service life of the operating fluid in the first operating year.

The service life may deviate from the reference value specified depending on thermic and chemical loads, and the accumulation of suspended particles and condensate in the operating fluid.



Operating fluid type

Fundamentally, when filling, refilling, or changing operating fluid, you must always use the operating fluid type specified on the rating plate. Should process conditions change, you can convert to a different operating fluid type.



Safety data sheets

You can obtain the safety data sheets for operating fluids from Pfeiffer Vacuum on request, or from the [Pfeiffer Vacuum Download Center](#).

The usable life of operating fluid is dependent on the area of application of the rotary vane vacuum pumps.

Instructions for when operating fluid should be changed

- The vacuum pump does not reach the specified ultimate pressure.
- Operating fluid is perceptibly polluted, milky, or cloudy when viewed through the sight glass.
- It is possible to detect thermal aging of the operating fluid from its color identification number (applies to mineral oils only).

7.3.1 Determine degree of aging of P3 operating fluid

WARNING

Health hazard and risk of environmental damage from toxic contaminated operating fluid

Toxic process media can cause operating fluid contamination. When changing the operating fluid, there is a health hazard due to contact with poisonous substances. Illegal disposal of toxic substances causes environmental damage.

- ▶ Wear suitable personal protective equipment when handling these media.
- ▶ Dispose of the operating fluid according to locally applicable regulations.

You can determine the degree of aging of P3 operating fluid in clean processes using the color chart (in accordance with DIN 51578). The supplementary sheet with the document number PK0219 can be obtained from the [Pfeiffer Vacuum Download Center](#).

Prerequisites

- Vacuum pump switched off
- Vacuum pump is vented to atmospheric pressure on the suction side
- Vacuum pump cooled

Required aids

- Test tube
- Pipette with flexible hose

Determine degree of aging of P3 operating fluid

1. Unscrew the filler screw.
2. Use the pipette to extract a sample of the operating fluid from the filling port.
3. Pour the sample into a test tube.
4. Check the sample in bright light.
5. If it is a reddish-brown color at the latest (corresponding with color identification number 5), change the operating fluid.
6. Screw in the filler screw.

7.3.2 Changing the operating fluid**⚠ WARNING****Health hazard and risk of environmental damage from toxic contaminated operating fluid**

Toxic process media can cause operating fluid contamination. When changing the operating fluid, there is a health hazard due to contact with poisonous substances. Illegal disposal of toxic substances causes environmental damage.

- ▶ Wear suitable personal protective equipment when handling these media.
- ▶ Dispose of the operating fluid according to locally applicable regulations.

⚠ CAUTION**Scalding from hot operating fluid**

Danger of burns when draining operating fluid if it comes into contact with the skin.

- ▶ Wear protective equipment.
- ▶ Use a suitable collection vessel.

**Cleaning by changing the operating fluid**

Pfeiffer Vacuum recommends, in cases of heavy contamination with process residues, cleaning the inside of the vacuum pump with several operating fluid changes.

**Notes on changing the operating fluid**

- Drain the operating fluid in warm state, if possible.
- Tilt the vacuum pump forwards slightly to completely empty it.

Prerequisites

- Vacuum pump switched off
- Vacuum pump vented to atmospheric pressure
- Vacuum pump has cooled so that it can be touched
- Operating fluid still warm

Required consumable material

- Operating fluid

Required tools

- Ring spanner, **WAF 32**
- Ring spanner, **WAF 27**

Required aids

- Collection receptacle (> 2 l)

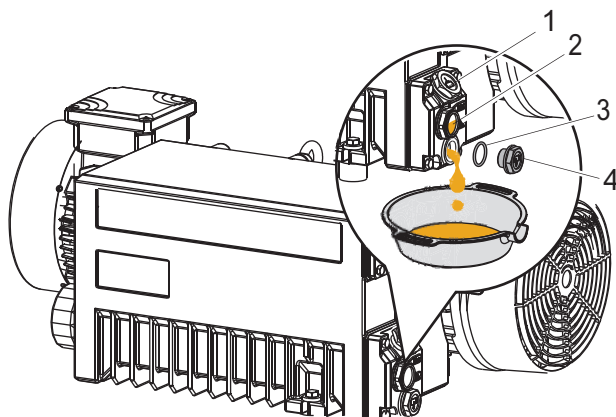

Fig. 16: Draining the operating fluid

- | | |
|----------------|---------------|
| 1 Filler screw | 3 O-ring |
| 2 Sight glass | 4 Drain screw |

Draining the operating fluid

1. Unscrew the filler screw.
 - Be careful with the O-ring.
2. Place a collection vessel below the drain hole.
3. Unscrew the drain screw.
 - Be careful with the O-ring.
4. Allow operating fluid to drain into collection vessel.

Filling fresh operating fluid

1. Screw in the drain screw.
 - Be careful with the O-ring.
2. Fill new operating fluid.
3. Check level.
4. Screw in the filler screw.
 - Be careful with the O-ring.

7.3.3 Rinsing and cleaning the rotary vane vacuum pump



Cleaning by changing the operating fluid

Pfeiffer Vacuum recommends, in cases of heavy contamination with process residues, cleaning the inside of the vacuum pump with several operating fluid changes.

Required consumable material

- Operating fluid
- Maintenance set level 1

Required aids

- Collection receptacle (> 7 l)

Change operating fluid for cleaning

1. Operate the vacuum pump with the gas ballast open, until it is warm.
2. Perform an operating fluid change.
3. Check the pollution level and repeat the changing of the operating fluid if necessary.
4. In case of highly contaminated operating fluid, replace the operating fluid filter and the exhaust filter.

7.3.4 Changing the operating fluid filter

The operating fluid filter must be changed:

- in event of saturation
 - You can recognize a saturated operating fluid filter by the fact that the filter housing is cool on the outside while the rotary vane pump is running at operating temperature.
- with each operating fluid change
- according to the maintenance level

Prerequisites

- Vacuum pump switched off
- Vacuum pump vented to atmospheric pressure
- Operating fluid drained

Required tool

- Strap wrench

Required aids

- Collection receptacle (> 1 l)

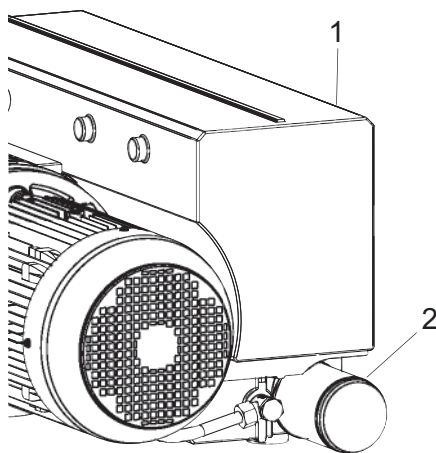

Fig. 17: Change operating fluid filter

- 1 Operating fluid separator 2 Operating fluid filter

Procedure

1. Place a collection receptacle below the operating fluid filter.
2. Unscrew the operating fluid filter using a strap wrench.
 - Pay attention to escaping operating fluid.
3. Apply oil to the sealing surface of the operating fluid filter.
4. Screw the operating fluid filter on finger-tight.

7.4 Change the exhaust filter in the operating fluid separator

⚠ WARNING

Health hazard through poisoning from toxic contaminated components or devices

Toxic process media result in contamination of devices or parts of them. During maintenance work, there is a risk to health from contact with these poisonous substances. Illegal disposal of toxic substances causes environmental damage.

- ▶ Take suitable safety precautions and prevent health hazards or environmental pollution by toxic process media.
- ▶ Decontaminate affected parts before carrying out maintenance work.
- ▶ Wear protective equipment.

**Change the exhaust filter annually**

Pfeiffer Vacuum recommends replacing the exhaust filter in the operating fluid separator annually, depending on the work process and the contamination incurred during the process.

Signs for saturation of the exhaust filter:

- higher current consumption of the motor
- increased emission of operating fluid mist at the gas outlet
- increased pressure in the operating fluid separator (pressure gage display in the red area).

Continuous monitoring of the filter resistance

- ▶ To continually monitor the filter resistance, use a manometer from the Pfeiffer Vacuum accessories instead of the filler screw.

7.4.1 Dismantling the exhaust filters

**Number of exhaust filters may deviate from the example**

Depending on the type of vacuum pump, between 1 and 8 exhaust filters are used. Filter changing is described using 2 exhaust filters as an example.

- Always change all existing exhaust filters.
- Also change exhaust filters that are located behind the blind cover.

Prerequisites

- Vacuum pump switched off
- Vacuum pump vented to atmospheric pressure
- Vacuum pump cooled

Required consumable material

- Maintenance set level 1

Required tool

- Hexagonal wrench **SW 10**

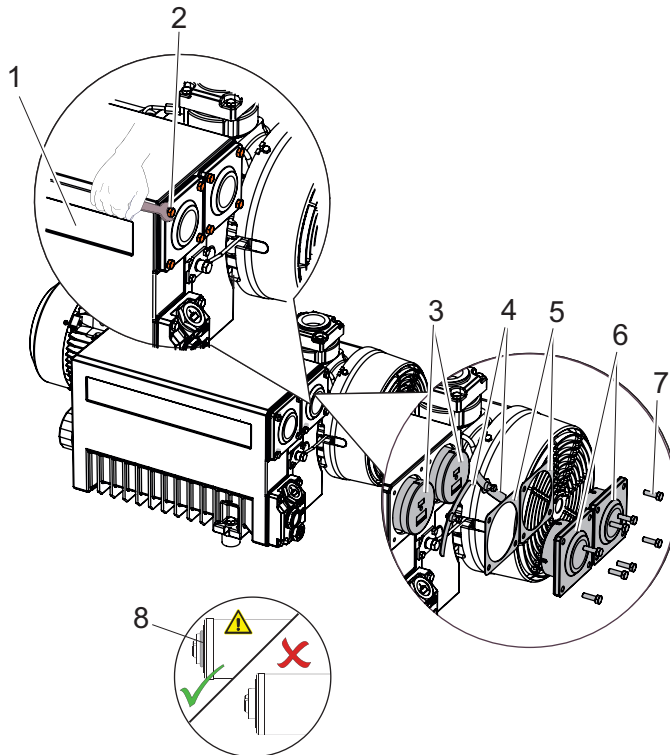

Fig. 18: Dismantling the exhaust filters

- | | |
|-----------------------------|-------------------------------|
| 1 Operating fluid separator | 5 Flat seal |
| 2 Exhaust line | 6 Separator cover plate |
| 3 Exhaust filter | 7 Hexagon head set screw (8×) |
| 4 Filter spring | 8 O-ring on exhaust filter |

Procedure

1. Remove the exhaust line.
2. Remove the separator cover plate.
 - Pay attention to the flat seal.
3. Loosen the screw and relieve tension in the filter spring.
 - Do not remove the screw.
4. Press the filter spring out of the recesses.
5. Remove the filter spring.
6. Pull the exhaust filter completely out of the operating fluid separator.
7. Replace the exhaust filter.

7.4.2 Mounting the exhaust filters

Prerequisites

- Vacuum pump switched off
- Vacuum pump vented to atmospheric pressure
- Vacuum pump cooled

Required consumable material

- Maintenance kit – Maintenance level 1

Required tools

- Hexagonal wrench **SW 10**
- Calibrated torque wrench (tightening factor ≤ 2.5)

Procedure

1. Install the exhaust filter
 - Be careful with the O-ring.
 - The arrow on the filter indicates the installation orientation. The arrow must point upwards (↑).
2. Insert the filter spring in the operating fluid separator.

3. Check the screw in the filter spring.
 - The tip of the screw must project approx. 2 to 5 turns of the thread beyond the filter spring.
4. Fit the separator cover plate with new flat seal.
5. Tighten the screws on the separator cover plate evenly.
 - Tightening torque: **6 Nm**
6. Assemble the exhaust line.

7.5 Cleaning the gas ballast filter

The gas ballast filter is soiled if the vacuum pump takes in ambient air containing dust during gas ballast operation.

As the soiling increases, the throughput of the gas ballast filter decreases. The risk of condensation and corrosion in the vacuum pump increases.

Required consumable materials

- Compressed air
- Industrial alcohol
- Soft cloth (lint-free)

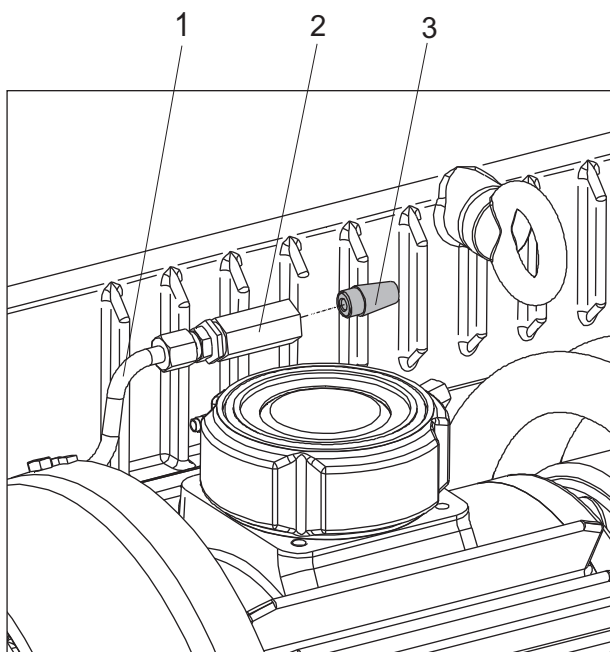

Fig. 19: Cleaning the gas ballast filter

- | | |
|---------------------|----------------------|
| 1 Gas ballast line | 3 Gas ballast filter |
| 2 Gas ballast valve | |

Removing and cleaning the gas ballast filter

1. Dismantle the gas ballast filter.
2. Clean the gas ballast filter using alcohol.
3. Blow out the gas ballast filter from inside to out using compressed air.
4. Replace the gas ballast filter in the event of major contamination or damage.
5. Check the gas ballast line for congestion.
6. If a gas ballast line is plugged, disassemble it.
7. Blow out the gas ballast line using compressed air.

7.6 Cleaning the operating fluid return line

In order to guarantee correct functioning of the operating fluid return, Pfeiffer Vacuum recommends cleaning the operating fluid return line and the float valve:

- with each operating fluid change
- with each exhaust filter change

This allows the vacuum pump to reach the final pressure and no operating fluid escapes at the exhaust flange.

Prerequisites

- Vacuum pump switched off
- Vacuum pump vented to atmospheric pressure
- Vacuum pump cooled
- Operating fluid drained
- Exhaust filter changed in the operating fluid separator

Required consumable material

- Operating fluid of the vacuum pump
- Parts according to the maintenance kit
- Compressed air

Required tool

- Hexagonal wrench, **WAF 4**

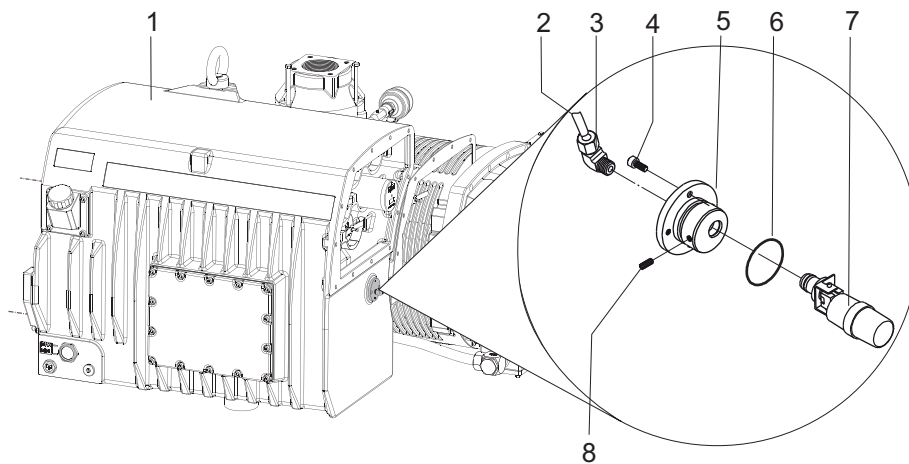

Fig. 20: Operating fluid return with float valve

- | | |
|-------------------------------|-------------------------|
| 1 Operating fluid separator | 5 Valve holder |
| 2 Operating fluid return line | 6 O-ring |
| 3 Elbow union | 7 Float valve |
| 4 Screws | 8 Grub screw, set screw |

Dismantle the float valve



Operating fluid leaks out

Small amounts of operating fluid may leak out when carrying out the work described below.

1. Where necessary, extract the remaining operating fluid from the float chamber inside the operating fluid separator.
2. Disconnect the operating fluid return line at the elbow union.
3. Remove the screws on the valve holder.
4. If necessary, the screws can be used to press down the valve holder.
5. Remove the valve holder with float valve whilst paying particular attention to the O-ring.
6. Loosen the grub screw in the valve holder.
7. Remove the float valve from the valve holder.

Clean the float valve and operating fluid return line

1. Clean the float valve.
2. Clean operating fluid return line with compressed air.

Mounting the float valve

1. Check the function of the float valve.
 - Make sure that the float moves easily by its own weight.
 - Make sure that the axial sealing surface on the floater is clean.
2. Mount the float valve in the correct installation position in the valve holder.
3. Mount the valve holder with a new o-ring onto the operating fluid separator.

4. Mount the elbow union and the operating fluid return line.
5. Refill the operating fluid.
6. Start up the vacuum pump.
7. Perform a final pressure test on the operating fluid return line to check for leaks.

7.7 Cleaning the intake strainer

The intake strainer in the vacuum connection upper section must be cleaned:

- when the throughput decreases
- if there is visible contamination

Prerequisites

- Vacuum pump switched off
- Vacuum pump is vented to atmospheric pressure on the suction side
- Vacuum pump cooled

Required tool

- Hexagonal wrench, **WAF 13**
- Calibrated torque wrench

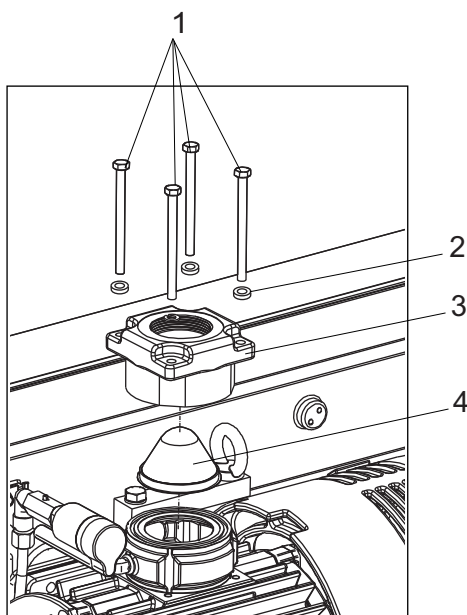

Fig. 21: Dismantling / assembling the intake strainer

- | | |
|-----------------------|---------------------|
| 1 Cylinder screw (4x) | 3 Vacuum connection |
| 2 Washer (4x) | 4 Intake strainer |

Dismantling the intake strainer

1. Dismantle the intake line.
2. Unscrew the cheesehead screws.
 - Pay attention to the washers.
3. Remove the vacuum connection.
4. Remove the intake strainer from the intake duct.
5. Dismantle the part of the non-return valve resting in the intake duct.

Clean all parts and examine for wear

1. Clean all parts.
2. Examine all parts for wear.

Assembling the intake strainer

1. Mount the parts of the non-return valve.
2. Insert the intake strainer into the intake duct.

3. Fit the vacuum connection.
4. Screw on the cylinder screws.
 - Pay attention to the washers.
 - Tightening torque: **20 Nm**

8 Decommissioning

8.1 Shutting down for longer periods

Before shutting down the vacuum pump, observe the following instructions to adequately protect the interior of the vacuum pump (pumping system) against corrosion:

1. Switch off the vacuum pump.
2. Vent the vacuum pump.
3. Allow the vacuum pump to cool down.
4. Remove the vacuum pump from the vacuum system if necessary.
5. Change the operating fluid.
6. Start the vacuum pump and bring it to operating temperature in order to wet the inside of the vacuum pump with fresh operating fluid.
7. Seal the connections with the original protective covers.
8. Store the vacuum pump in dry, dust-free rooms, within the specified ambient conditions.
9. Pack the vacuum pump together with a drying agent in a plastic bag, and seal the vacuum pump airtight if it is to be stored in rooms with damp or aggressive atmospheres.
10. For longer storage periods (> 2 years), Pfeiffer Vacuum recommends changing the operating fluid again prior to recommissioning.

8.2 Recommissioning

NOTICE

Risk of damage to vacuum pump as a result of operating fluid aging

The operating fluid usability is limited (max. 2 years). Prior to recommissioning, following a shutdown of **2 years or more**, carry out the following work.

- ▶ Change the operating fluid.
- ▶ Change the radial shaft seal rings and other elastomer parts if required.
- ▶ Observe the maintenance instructions – consult Pfeiffer Vacuum if necessary.

Changing the bearings

- ▶ For vacuum pumps with roller bearings, change the bearings.

9 Recycling and disposal

WARNING

Health hazard through poisoning from toxic contaminated components or devices

Toxic process media result in contamination of devices or parts of them. During maintenance work, there is a risk to health from contact with these poisonous substances. Illegal disposal of toxic substances causes environmental damage.

- ▶ Take suitable safety precautions and prevent health hazards or environmental pollution by toxic process media.
- ▶ Decontaminate affected parts before carrying out maintenance work.
- ▶ Wear protective equipment.



Environmental protection

You **must** dispose of the product and its components in accordance with all applicable regulations for protecting people, the environment and nature.

- Help to reduce the wastage of natural resources.
- Prevent contamination.



Environmental protection

The product and its components **must be disposed of in accordance with the applicable regulations relating to environmental protection and human health**, with a view to reducing natural resource wastage and preventing pollution.

9.1 General disposal information

Pfeiffer Vacuum products contain materials that you must recycle.

- ▶ Dispose of our products according to the following:
 - Iron
 - Aluminium
 - Copper
 - Synthetic
 - Electronic components
 - Oil and fat, solvent-free
- ▶ Observe the special precautionary measures when disposing of:
 - Fluoroelastomers (FKM)
 - Potentially contaminated components that come into contact with media

9.2 Dispose of rotary vane pump

Pfeiffer Vacuum rotary vane pumps contain materials that you must recycle.

1. Fully drain the lubricant.
2. Dismantle the motor.
3. Decontaminate the components that come into contact with process gases.
4. Separate the components into recyclable materials.
5. Recycle the non-contaminated components.
6. Dispose of the product or components in a safe manner according to locally applicable regulations.

10 Malfunctions

⚠ CAUTION

Danger of injury from moving parts

After a power failure or a standstill as a result of overheating, the motor restarts automatically. There is a risk of injury to fingers and hands if they enter the operating range of rotating parts.

- ▶ Safely disconnect motor from the mains.
- ▶ Secure the motor against reactivation.
- ▶ Dismantle the vacuum pump for inspection, away from the system if necessary.

⚠ CAUTION

Danger of burns on hot surfaces

In the event of a fault, the surface temperature of the vacuum pump can increase to above 105 °C.

- ▶ Allow the vacuum pump to cool down before carrying out any work.
- ▶ Wear personal protective equipment if necessary.

NOTICE

Danger of property damage from improper maintenance

Unprofessional work on the vacuum pump will lead to damage for which Pfeiffer Vacuum accepts no liability.

- ▶ When ordering spare parts, specify the information on the nameplate.

Should malfunctions occur, you can find information about potential causes and how to fix them here:

Problem	Possible causes	Remedy
Vacuum pump will not start up	<ul style="list-style-type: none"> • No mains voltage or voltage does not correspond to the motor data 	<ul style="list-style-type: none"> • Check the mains voltage and mains fuse • Check the motor switch.
	<ul style="list-style-type: none"> • Pump temperature too low 	<ul style="list-style-type: none"> • Heat the vacuum pump to > 12 °C.
	<ul style="list-style-type: none"> • Thermal protection switch has triggered 	<ul style="list-style-type: none"> • Determine and eliminate the cause. • Allow the vacuum pump to cool down as required.
	<ul style="list-style-type: none"> • Pumping system contaminated 	<ul style="list-style-type: none"> • Clean the vacuum pump. • Contact Pfeiffer Vacuum Service.
	<ul style="list-style-type: none"> • Pumping system damaged 	<ul style="list-style-type: none"> • Clean and maintain the vacuum pump. • Contact Pfeiffer Vacuum Service.
	<ul style="list-style-type: none"> • Motor faulty 	<ul style="list-style-type: none"> • Replace the motor.
Vacuum pump switches off after a while after being started	<ul style="list-style-type: none"> • Thermal protection switch of the motor has triggered 	<ul style="list-style-type: none"> • Determine and eliminate the cause of overheating. • Allow the motor to cool down as required.
	<ul style="list-style-type: none"> • Mains fuse triggered due to overload (e.g. cold start) 	<ul style="list-style-type: none"> • Bring vacuum pump to permissible ambient temperature range.
	<ul style="list-style-type: none"> • Exhaust pressure too high 	<ul style="list-style-type: none"> • Check exhaust line outlet openings and exhaust side accessories.

Problem	Possible causes	Remedy
Vacuum pump does not reach the specified final pressure	<ul style="list-style-type: none"> Measurement result distorted 	<ul style="list-style-type: none"> Check the measurement instrument. Check the final pressure without system connected.
	<ul style="list-style-type: none"> Vacuum pump or connected accessory contaminated 	<ul style="list-style-type: none"> Clean the vacuum pump. Check the components for contamination.
	<ul style="list-style-type: none"> Operating fluid contaminated 	<ul style="list-style-type: none"> Operate the vacuum pump with the gas ballast valve open over a longer period. Change the operating fluid.
	<ul style="list-style-type: none"> Operating fluid level too low 	<ul style="list-style-type: none"> Top up the operating fluid.
	<ul style="list-style-type: none"> Leak in system 	<ul style="list-style-type: none"> Locate and eliminate the leak.
	<ul style="list-style-type: none"> Vacuum pump is damaged 	<ul style="list-style-type: none"> Contact Pfeiffer Vacuum Service.
Pumping speed of vacuum pump too low	<ul style="list-style-type: none"> The intake line is not suitably dimensioned 	<ul style="list-style-type: none"> Make sure that connections are short and cross sections adequately dimensioned.
	<ul style="list-style-type: none"> Exhaust pressure too high 	<ul style="list-style-type: none"> Check exhaust line outlet openings and exhaust side accessories.
Loss of operating fluid	<ul style="list-style-type: none"> Operating fluid separator leaking 	<ul style="list-style-type: none"> Check for leaks. Replace the seal as required.
	<ul style="list-style-type: none"> Radial shaft seal rings (RSSR) leaking 	<ul style="list-style-type: none"> Contact Pfeiffer Vacuum Service.
	<ul style="list-style-type: none"> Operational loss of operating fluid 	<ul style="list-style-type: none"> Check the oil return.
Unusual noises during operation	<ul style="list-style-type: none"> Pumping system is contaminated or damaged 	<ul style="list-style-type: none"> Clean and maintain the vacuum pump. Contact Pfeiffer Vacuum Service.
	<ul style="list-style-type: none"> Motor bearing is faulty 	<ul style="list-style-type: none"> Change the motor. Contact Pfeiffer Vacuum Service.

Tbl. 10: Troubleshooting for rotary vane pumps

11 Service solutions by Pfeiffer Vacuum

We offer first-class service

High vacuum component service life, in combination with low downtime, are clear expectations that you place on us. We meet your needs with efficient products and outstanding service.

We are always focused on perfecting our core competence – servicing of vacuum components. Once you have purchased a product from Pfeiffer Vacuum, our service is far from over. This is often exactly where service begins. Obviously, in proven Pfeiffer Vacuum quality.

Our professional sales and service employees are available to provide you with reliable assistance, worldwide. Pfeiffer Vacuum offers an entire range of services, from [original replacement parts](#) to [service contracts](#).

Make use of Pfeiffer Vacuum service

Whether preventive, on-site service carried out by our field service, fast replacement with mint condition replacement products, or repair carried out in a [Service Center](#) near you – you have various options for maintaining your equipment availability. You can find more detailed information and addresses on our homepage, in the [Pfeiffer Vacuum Service](#) section.

You can obtain advice on the optimal solution for you, from your [Pfeiffer Vacuum representative](#).

For fast and smooth service process handling, we recommend the following:



1. Download the up-to-date form templates.
 - [Explanations of service requests](#)
 - [Service requests](#)
 - [Contamination declaration](#)



- a) Remove and store all accessories (all external parts, such as valves, protective screens, etc.).
 - b) If necessary, drain operating fluid/lubricant.
 - c) If necessary, drain coolant.
2. Complete the service request and contamination declaration.



3. Send the forms by email, fax, or post to your local [Service Center](#).



4. You will receive an acknowledgment from Pfeiffer Vacuum.

PFEIFFER VACUUM

Submission of contaminated products

No microbiological, explosive, or radiologically contaminated products will be accepted. Where products are contaminated, or the contamination declaration is missing, Pfeiffer Vacuum will contact you before starting service work. Depending on the product and degree of pollution, **additional decontamination costs** may be incurred.

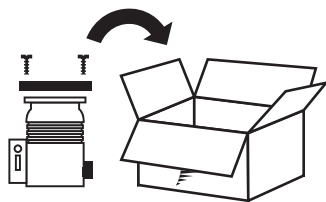

5. Prepare the product for transport in accordance with the provisions in the contamination declaration.
 - a) Neutralize the product with nitrogen or dry air.
 - b) Seal all openings with blind flanges, so that they are airtight.
 - c) Shrink-wrap the product in suitable protective foil.
 - d) Package the product in suitable, stable transport containers only.
 - e) Maintain applicable transport conditions.

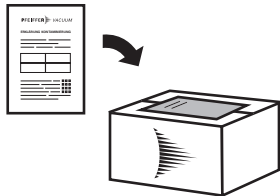

6. Attach the contamination declaration to the **outside** of the packaging.

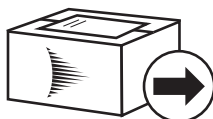

7. Now send your product to your local Service Center.

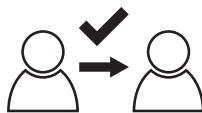

8. You will receive an acknowledgment/quotation, from Pfeiffer Vacuum.

PFEIFFER VACUUM

Our sales and delivery conditions and repair and maintenance conditions for vacuum devices and components apply to all service orders.

12 Spare parts

12.1 Operating fluids – Maintenance level 1

Select the respective operating fluid type and quantity under consideration of the details on the rating plate.

Description	Order number
P3, mineral oil, 1 l	PK 001 106 -T
P3, mineral oil, 5 l	PK 001 107 -T
P3, mineral oil, 20 l	PK 001 108 -T
D1, synthetic diester based oil, 1 l	PK 005 875 -T
D1, synthetic diester based oil, 5 l	PK 005 876 -T

Tbl. 11: Consumables

12.2 Maintenance kit – maintenance level 1

The maintenance kit contains:

- Filler and drain screw seals for one operating fluid change
- Seals of the separator cover plate for cleaning the oil chamber
- Exhaust filter
- Operating fluid filter
- Filter material

12.3 Overhaul kit – maintenance level 3

The overhaul kit contains all the wear parts of the vacuum pump that must be replaced after the vacuum pump has been dismantled and cleaned:

- Set of seals with all seals relevant for the function
- Bearing
- Intake strainer
- Operating fluid and exhaust filters
- Wearing parts of the valves
- Coupling sleeve

12.4 Set of seals

The set of seals contains:

- all seals from the main- and sub-assemblies,
- Radial shaft seal rings (RSSR)

12.5 Set of vanes

The set of vanes contains:

- Vane

12.6 Ordering spare parts packages

Procedure

1. Have the vacuum pump part number to hand, along with other details from the rating plate.
2. Install original spare parts only.

Spare parts package	Pump type	Order number
Set of seals	Hena 61	PK E60 021 -T
	Hena 101	
Maintenance kit	Hena 61	PK E61 021 -T
	Hena 101	
Overhaul kit without vane	Hena 61	PK E62 022 -T
	Hena 101	PK E62 023 -T
Set of vanes	Hena 61	PK E68 022 -T
	Hena 101	PK E68 023 -T
Operating fluid filter	Hena 61	PK 100 129
	Hena 101	
Gas ballast filter	Hena 61	PK 100 170 -U
	Hena 101	

Tbl. 12: Spare parts packages

13 Accessories



View the [range of accessories for rotary vane pumps](#) on our website.

13.1 Accessory information

Condensate separator

Protects the vacuum pump against fluids from the intake line and from the condensate return from the exhaust line

Dust separators

Protects the vacuum pump from particles out of the process

Activated carbon filter

Protects the vacuum pump and the operating fluid against gaseous contaminants with assembly on the intake side and lowers the concentration of damaging exhaust products with assembly on the exhaust side

Sorption trap

Prevents the backflow of hydrocarbons when using mineral operating fluid (P3)

Screwing flange

Enables the connection of components with ISO-K

Manual gas ballast valve

A ball valve enables the gas ballast unit to be sealed in order to reach a lower final pressure

Locking screw

Permanently locks the gas ballast unit

Magnetized gas ballast valve

Enables remote control of the gas ballast unit, operation with 24 VDC

Pressure gauge

Monitors the saturation of the exhaust filter

Operating fluid level switch unit

Monitors the operating fluid level of the vacuum pump and activates a switching contact when the minimum filling level is reached

PTC resistor tripping unit for motor protection

Monitors the temperature of the motor winding

13.2 Ordering accessories

Description	Order number
Sorption Trap ST 40, 230 V	053380
Sorption Trap ST 40, 115 V	104371
Operating Fluid Level Switch	PK 100 138 -T
SAS 40, DN 40 ISO-KF, polyester filter	PK Z60 510
KAS 40, Condensate Separator	PK Z10 008
FAK 040, activated carbon filter	PK Z30 008
Screw-in flange DN 40 ISO-KF / G 1 1/4"	PK 300 525
Manometer for monitoring the operating fluid separator G 3/4"	PK 100 126
PTC Resistor Tripping Device 24 V AC/DC	P 4768 052 FE
PTC Resistor Tripping Device 220 – 240 V AC	P 4768 052 FQ
Locking Screw A2B, G 1/8 A with Seal FPM	N 3191 431 5P
Gas ballast valve manually actuated	PK 100 150

Description	Ordner number
Gas Ballast Valve with Solenoid Valve	PK 100 143 -U
Gas Ballast Valve with Solenoid Valve	PK 100 144 -U

Tbl. 13: Accessories for Hena 61 | Hena 101

14 Technical data and dimensions

14.1 General

Basis for the technical data of Pfeiffer Vacuum rotary vane pumps:

- Specifications according to PNEUROP committee PN5
- ISO 21360-1: 2016: "Vacuum technology - Standard methods for measuring vacuum-pump performance - Part 1: General description"
- Leak test to ascertain the integral leakage rate according to EN 1779: 1999 technique A1; with 20 % helium concentration, 10 s measurement duration
- Sound pressure level according to ISO 3744, class 2

	mbar	bar	Pa	hPa	kPa	Torr mm Hg
mbar	1	$1 \cdot 10^{-3}$	100	1	0.1	0.75
bar	1000	1	$1 \cdot 10^5$	1000	100	750
Pa	0.01	$1 \cdot 10^{-5}$	1	0.01	$1 \cdot 10^{-3}$	$7.5 \cdot 10^{-3}$
hPa	1	$1 \cdot 10^{-3}$	100	1	0.1	0.75
kPa	10	0.01	1000	10	1	7.5
Torr mm Hg	1.33	$1.33 \cdot 10^{-3}$	133.32	1.33	0.133	1

$$1 \text{ Pa} = 1 \text{ N/m}^2$$

Tbl. 14: Conversion table: Pressure units

	mbar l/s	Pa m ³ /s	sccm	Torr l/s	atm cm ³ /s
mbar l/s	1	0.1	59.2	0.75	0.987
Pa m ³ /s	10	1	592	7.5	9.87
sccm	$1.69 \cdot 10^{-2}$	$1.69 \cdot 10^{-3}$	1	$1.27 \cdot 10^{-2}$	$1.67 \cdot 10^{-2}$
Torr l/s	1.33	0.133	78.9	1	1.32
atm cm ³ /s	1.01	0.101	59.8	0.76	1

Tbl. 15: Conversion table: Units for gas throughput

14.2 Technical data

Classification	Hena 61	Hena 61	Hena 61	Hena 61
Part number	PK D04 121 111	PK D04 121 112	PK D04 121 121	PK D04 121 122
Final pressure without gas ballast	$\leq 5 \cdot 10^{-1}$ hPa	$\leq 1.5 \cdot 10^{-1}$ hPa	$\leq 5 \cdot 10^{-1}$ hPa	$\leq 1.5 \cdot 10^{-1}$ hPa
Final pressure with gas ballast	≤ 1.5 hPa	≤ 1.5 hPa	≤ 1.5 hPa	≤ 1.5 hPa
Leak rate safety valve	$\leq 8 \cdot 10^{-3}$ Pa m ³ /s	$\leq 8 \cdot 10^{-3}$ Pa m ³ /s	$\leq 8 \cdot 10^{-3}$ Pa m ³ /s	$\leq 8 \cdot 10^{-3}$ Pa m ³ /s
Emission sound pressure level without gas ballast at 60 Hz	≤ 67 dB(A)	≤ 67 dB(A)	≤ 67 dB(A)	≤ 67 dB(A)
Emission sound pressure level without gas ballast at 50 Hz	≤ 64 dB(A)	≤ 64 dB(A)	≤ 64 dB(A)	≤ 64 dB(A)
Continuous inlet pressure, max.	800 hPa	800 hPa	800 hPa	800 hPa
Motor version	3-ph motor	3-ph motor	3-ph motor	3-ph motor
Rated power 50 Hz	2 kW	2 kW	2 kW	2 kW
Rated power 60 Hz	2.4 kW	2.4 kW	2.4 kW	2.4 kW
Cooling method	Air	Air	Air	Air
Nominal pumping speed at 50 Hz	63 m ³ /h	63 m ³ /h	63 m ³ /h	63 m ³ /h
Nominal pumping speed at 60 Hz	76 m ³ /h	76 m ³ /h	76 m ³ /h	76 m ³ /h
Rotation speed at 50 Hz	1500 rpm	1500 rpm	1500 rpm	1500 rpm
Rotation speed at 60 Hz	1800 rpm	1800 rpm	1800 rpm	1800 rpm

Classification	Hena 61	Hena 61	Hena 61	Hena 61
Mains connection: voltage 50 Hz	190–200/380–400 V	190–200/380–400 V	200/346 V	200/346 V
Mains connection: voltage 60 Hz	208/220/230/440/460 V	208/220/230/440/460 V	220/380 V	220/380 V
Mains requirement: voltage (range)	±5 %	±5 %	±5 %	±5 %
Mains cable included	No	No	No	No
Gas ballast	Yes	Yes	Yes	Yes
Switch	No	No	No	No
Connection: Atmospheric side	Female thread G 1¼"	Female thread G 1¼"	Female thread G 1¼"	Female thread G 1¼"
Connection: Vacuum side	Female thread G 1¼"	Female thread G 1¼"	Female thread G 1¼"	Female thread G 1¼"
Operating fluid	D1	P3	D1	P3
Operating fluid amount	2 l	2 l	2 l	2 l
Ambient temperature	5 – 40 °C	5 – 35 °C	5 – 40 °C	5 – 35 °C
Shipping and storage temperature	-25 – 55 °C	-25 – 55 °C	-25 – 55 °C	-25 – 55 °C
Protection degree	IP55	IP55	IP55	IP55
Weight	64.5 kg	64.5 kg	64.5 kg	64.5 kg

Tbl. 16: Technical data Hena 61

Classification	Hena 101	Hena 101	Hena 101	Hena 101
Part number	PK D04 131 111	PK D04 131 112	PK D04 131 121	PK D04 131 122
Final pressure without gas ballast	$\leq 5 \cdot 10^{-1}$ hPa	$\leq 1.5 \cdot 10^{-1}$ hPa	$\leq 5 \cdot 10^{-1}$ hPa	$\leq 1.5 \cdot 10^{-1}$ hPa
Final pressure with gas ballast	≤ 1.5 hPa	≤ 1.5 hPa	≤ 1.5 hPa	≤ 1.5 hPa
Leak rate safety valve	$\leq 8 \cdot 10^{-3}$ Pa m ³ /s	$\leq 8 \cdot 10^{-3}$ Pa m ³ /s	$\leq 8 \cdot 10^{-3}$ Pa m ³ /s	$\leq 8 \cdot 10^{-3}$ Pa m ³ /s
Emission sound pressure level without gas ballast at 60 Hz	≤ 68 dB(A)	≤ 68 dB(A)	≤ 68 dB(A)	≤ 68 dB(A)
Emission sound pressure level without gas ballast at 50 Hz	≤ 65 dB(A)	≤ 65 dB(A)	≤ 65 dB(A)	≤ 65 dB(A)
Continuous inlet pressure, max.	800 hPa	800 hPa	800 hPa	800 hPa
Motor version	3-ph motor	3-ph motor	3-ph motor	3-ph motor
Rated power 50 Hz	2.7 kW	2.7 kW	2.7 kW	2.7 kW
Rated power 60 Hz	3.4 kW	3.4 kW	3.4 kW	3.4 kW
Cooling method	Air	Air	Air	Air
Nominal pumping speed at 50 Hz	100 m ³ /h	100 m ³ /h	100 m ³ /h	100 m ³ /h
Nominal pumping speed at 60 Hz	120 m ³ /h	120 m ³ /h	120 m ³ /h	120 m ³ /h
Rotation speed at 50 Hz	1500 rpm	1500 rpm	1500 rpm	1500 rpm
Rotation speed at 60 Hz	1800 rpm	1800 rpm	1800 rpm	1800 rpm
Mains connection: voltage 50 Hz	190–200/380–400 V	190–200/380–400 V	200/346 V	200/346 V
Mains connection: voltage 60 Hz	208/220/230/440/460 V	208/220/230/440/460 V	220/380 V	220/380 V
Mains requirement: voltage (range)	±5 %	±5 %	± 5 %	± 5 %
Mains cable included	No	No	No	No
Gas ballast	Yes	Yes	Yes	Yes
Switch	No	No	No	No
Connection: Atmospheric side	Female thread G 1¼"	Female thread G 1¼"	Female thread G 1¼"	Female thread G 1¼"
Connection: Vacuum side	Female thread G 1¼"	Female thread G 1¼"	Female thread G 1¼"	Female thread G 1¼"

Classification	Hena 101	Hena 101	Hena 101	Hena 101
Operating fluid	D1	P3	D1	P3
Operating fluid amount	2 l	2 l	2 l	2 l
Ambient temperature	5 – 40 °C	5 – 35 °C	5 – 40 °C	5 – 35 °C
Shipping and storage temperature	-25 – 55 °C	-25 – 55 °C	-25 – 55 °C	-25 – 55 °C
Protection degree	IP55	IP55	IP55	IP55
Weight	78 kg	78 kg	78 kg	78 kg

Tbl. 17: Technical data Hena 101

14.3 Dimensions

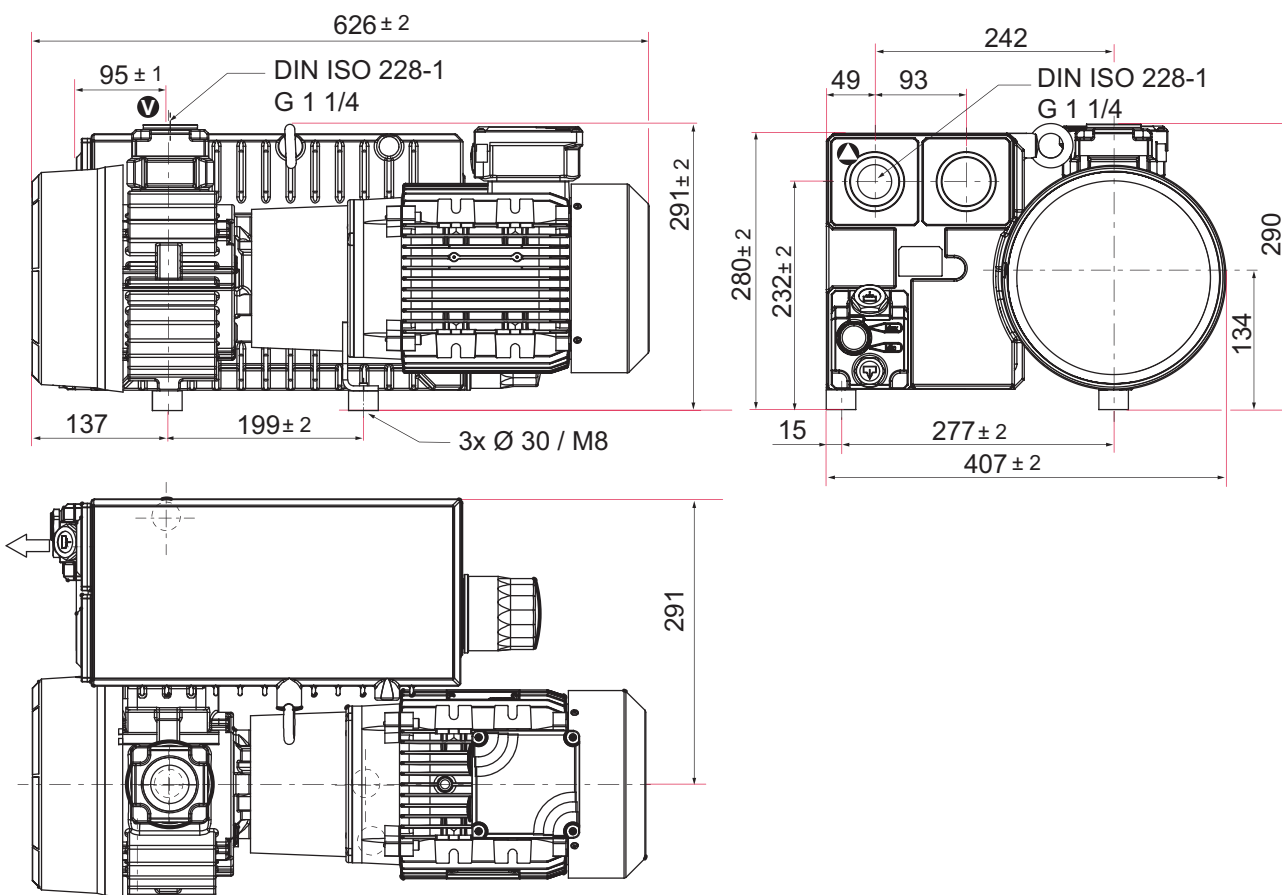

Fig. 22: Dimensions Hena 61
Dimensions in mm

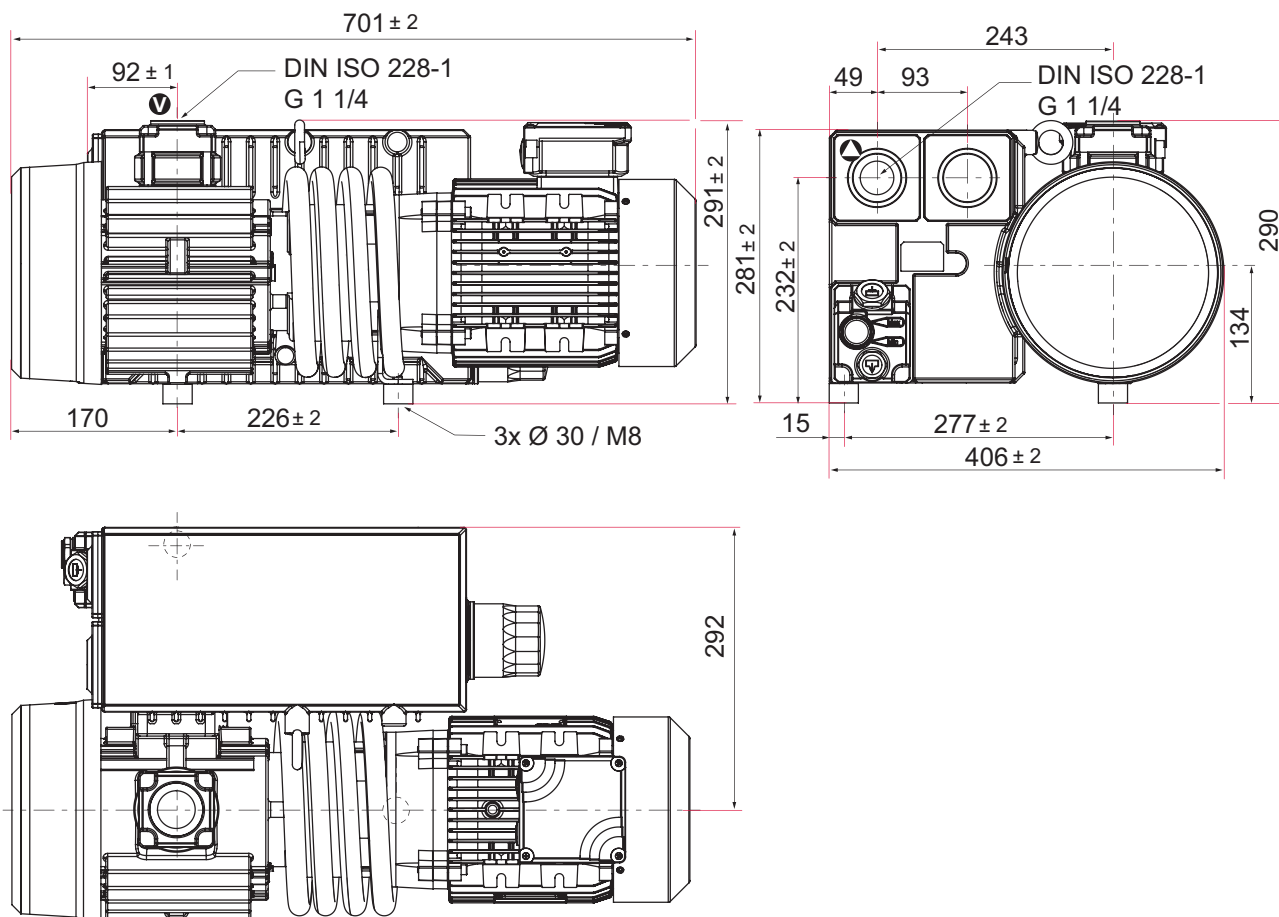

Fig. 23: Dimensions Hena 101
 Dimensions in mm

Declaration of conformity

Declaration for product(s) of the type:

Rotary vane pump

Hena 61

Hena 101

We hereby declare that the listed product satisfies all relevant provisions of the following **European Directives**.

Machinery 2006/42/EC (Annex II, no. 1 A)

Electromagnetic compatibility 2014/30/EU

Restriction of the use of certain hazardous substances 2011/65/EU

Restriction of the use of certain hazardous substances, delegated directive 2015/863/EU

Harmonized standards and applied national standards and specifications:

DIN EN ISO 12100: 2011-03

DIN EN 60204-1: 2019-06

DIN EN ISO 13857: 2008-06

DIN EN 61000-6-2: 2006-03

DIN EN 1012-1: 2011-02

DIN EN 61000-6-4: 2011-09

DIN EN 1012-2 : 2011-12

DIN EN ISO 2151 : 2009-01

DIN EN 13849-1: 2016-06

The authorized representative for the compilation of technical documents is Mr. Wolfgang Bremer, Pfeiffer Vacuum GmbH, Berliner Straße 43, 35614 Asslar, Germany.

Signature:



(Daniel Sälzer)
Managing Director

Pfeiffer Vacuum GmbH
Berliner Straße 43
35614 Asslar
Germany

Asslar, 2020-03-06



VACUUM SOLUTIONS FROM A SINGLE SOURCE

Pfeiffer Vacuum stands for innovative and custom vacuum solutions worldwide, technological perfection, competent advice and reliable service.

COMPLETE RANGE OF PRODUCTS

From a single component to complex systems:

We are the only supplier of vacuum technology that provides a complete product portfolio.

COMPETENCE IN THEORY AND PRACTICE

Benefit from our know-how and our portfolio of training opportunities!

We support you with your plant layout and provide first-class on-site service worldwide.

ed. C - Date 2005 - P/N:PD00866BEN



Are you looking for a
perfect vacuum solution?
Please contact us

Pfeiffer Vacuum GmbH
Headquarters • Germany
T +49 6441 802-0
info@pfeiffer-vacuum.de

www.pfeiffer-vacuum.com

PFEIFFER  **VACUUM**