

TURBOVAC i/iX

Power Supply TURBO.POWER integra

Brief Instructions 300450827_002_C2

P/N 800100V0003

Description

The TURBO.POWER integra is a power supply unit for powering the following turbomolecular pumps:

TURBOVAC 350 i / iX, 450 i / iX

TURBOVAC 350/xx i, 450/xx i

TURBOVAC 350/xxx/xx i / iC

TURBOVAC 400/xxx/xx i / iC

The mains input is protected by a fuse.

The TURBO.POWER integra can be fitted to the pump or utilized as a benchtop unit.

Supplied Equipment

Power supply unit, 30 cm long cable TURBOVAC i/iX - TURBO.POWER integra and 3 bolts and 3 distance bolts for fitting to the pump, 3 feet for utilization as a benchtop unit.

Accessories

Cable TURBOVAC i/iX - TURBO.POWER integra, 1 m	800096V0100
3 m	800096V0300
5 m	800096V0500
Mains cable for TURBO.POWER integra, 3 m long with Euro plug	800102V0002
with UK plug	800102V0003
with US plug 6-15 P, 115 V	800102V1002



Fig. 1 TURBO.POWER integra

Technical Data

Input	
Mains voltage	100 - 240 VAC, 50/60 Hz
Max. power consumption	403 VA
Efficiency	85 %
Leakage current	2 mA / 230 VDC
AC fusing	5 A, slow-blow
Output	
Nominal DC output voltage	24 V \pm 5% (SELV)
Max. DC continuous current	8 A
DC peak current (60 s)	10 A
Max. rated power output	252 W
Other data	
Weight	1.2 kg
Protection type (EN 60529)	IP 40
Ambient temperature during operation	5 – 45 °C
in storage	-15 – +70 °C
Relative air humidity	5 to 85 % non condensing
Overvoltage category	II
Contamination grade	2
Resistance to interference	61000-6-2 Industry
Interference sourcing	61000-6-3 Household
Max. operating altitude	2000 m above sea level, up to 3000 m with 1%/100 m derating

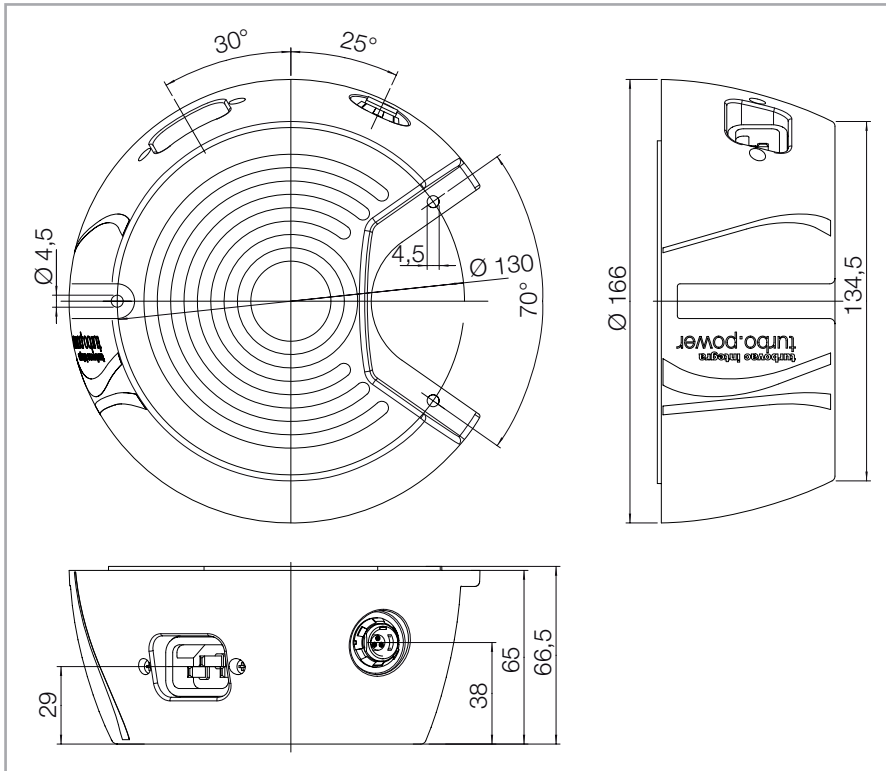

Fig. 2 Dimensional drawing; dimensions in mm

Installation

Note the safety information given in the Operating Instructions for the pump.

Connect or disconnect cable connections only provided the consumers are non-operative **and** after having switched off the mains power first. Connecting or disconnecting the cable connections with the mains power present or with the pump turning, can destroy the components.

The TURBO.POWER integra must only be opened by certified Leybold Service Centres. Opening by unauthorised personnel voids warranty.

Note also the information given in the Operating Instructions for the pump.

CAUTION



NOTICE

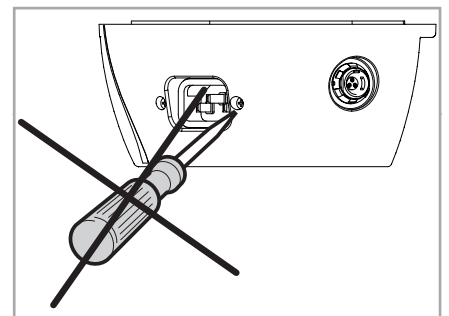

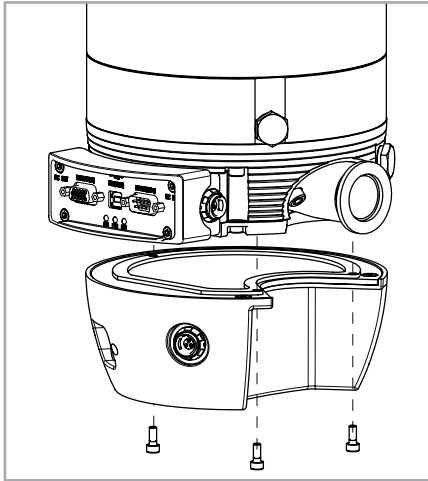

Fig. 3 Fitting to the pump

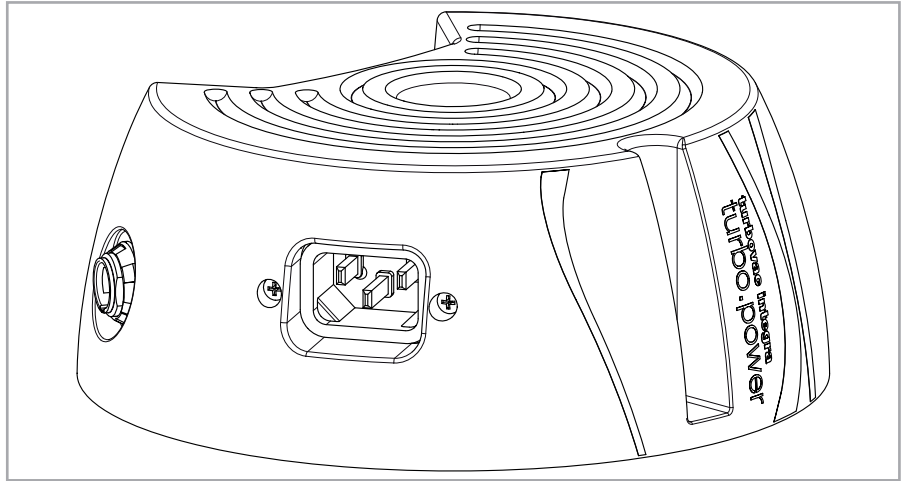

Fig. 4 Benchtop unit

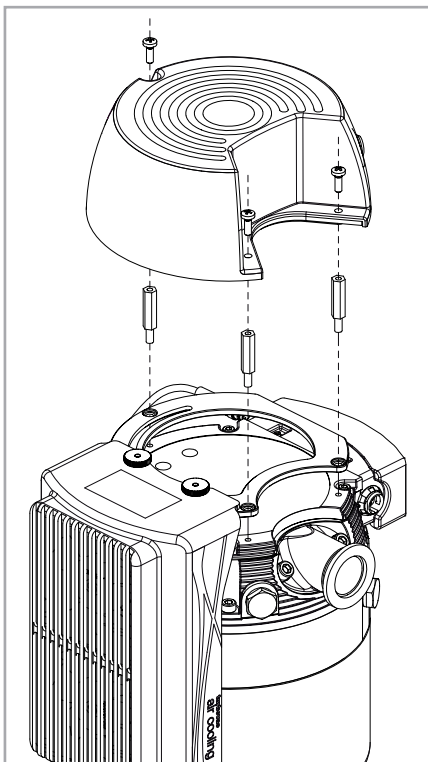

Fig. 5 Fitting to the pump with distance bolts

Installation to the pump

Affix the power supply unit using 3 bolts screwed into the holes provided on the TURBOVAC. If the power supply unit is mounted together with the radial air cooler use the supplied distance bolts.

Utilization as a benchtop unit

Fix the supplied adhesive feet to the power supply and place the unit on an even, level surface.

Insert the connecting cable between pump and TURBO.POWER integra. The necessary 0.3 m long connecting cable is included in the delivery. For utilization as a benchtop unit, longer connecting cables are available as an accessory.

The TURBO.POWER integra is not equipped with a mains switch. As soon as the mains cable has been connected, the unit will power up. Then the yellow LED at the frequency converter lights up.

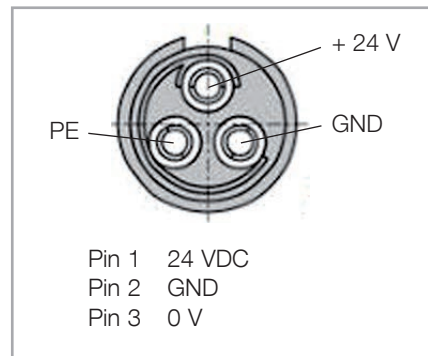

Fig. 6 Pin assignment at the power supply unit

Operation

The turbomolecular pump and the TURBO.POWER integra must only be operated if installed in compliance with the information provided in the Operating Instructions.

CAUTION



Switching on

Plug the mains cable in. Secure the mains cable so that it cannot be pulled out inadvertently. The mains power supply must be coordinated (have an earth connection).

Switch the turbomolecular pump on and then off, see Operating Instructions for the turbomolecular pump. The turbomolecular pump will only start when inserting the mains cable provided a start command is present.

Shutting down

Switch off the pump at the frequency converter.

After switching off, the green status LED will flash until the rotor of the turbomolecular pump is at standstill. This may take several minutes. With the DC power supply off, the turbomolecular pump will act as a generator supplying the frequency converter with energy as indicated by the yellow power LED.

To shut down the frequency converter, switch the pump off and wait until the rotor of the turbomolecular pump has arrived at standstill (green status LED off).

Then disconnect the mains plug.

Emergency shut down

For emergency shutdown disconnect the mains plug.

Maintenance

The TURBO.POWER integra is maintenance free. Repairs must only be done by Leybold.

During all work on the, the system must be protected against being switched on. For this disconnect the mains plug.

EU Declaration of Conformity

(Translation of original Declaration of Conformity)

The manufacturer: Leybold GmbH
Bonner Strasse 498
D-50968 Köln
Germany

herewith declares that the products specified and listed below which we have placed on the market, comply with the applicable EU Council Directives. This declaration becomes invalid if modifications are made to the product without agreement of Leybold GmbH.

Product designation: Power Supply
Type designation: TURBO.POWER integra
Part numbers: 800100V0003

The product complies to the following European Council Directives:

Low Voltage Directive (2014/35/EU)
Electromagnetic Compatibility (2014/30/EU)
Directive RoHS (2011/65/EU) & (2015/863)

The following harmonized standards have been applied:

EN 61010-1:2010 Safety requirements for electrical equipment for measurement, control, and laboratory use — Part 1: General requirements

EN 61326-1:2013 Electrical equipment for measurement, control and laboratory use — EMC requirements — Part 1: General requirements
Emissions: Group 1, Class B
Immunity: Industrial electromagnetic environment

EN IEC 63000:2018 Technical documentation for the assessment of electrical and electronic products with respect to the restriction of hazardous substances

Documentation officer: Leybold GmbH, Bonner Straße 498, D-50968 Köln
T: +49(0)221 347 0
F: +49(0)221 347 1250
documentation@leybold.com

Cologne, June 26th, 2020



Dr. Thomas Dreifert
Manager Engineering
Product Company Cologne

Cologne, June 26th, 2020

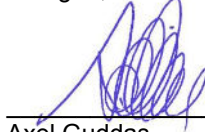

Axel Guddas
General Manager
Product Company Cologne