

SINCE 1889



Yamato

Photo Absorbance Sensor

PiCOEXPLORER

User's Manual and Troubleshooting Guide

PAS-110-YU

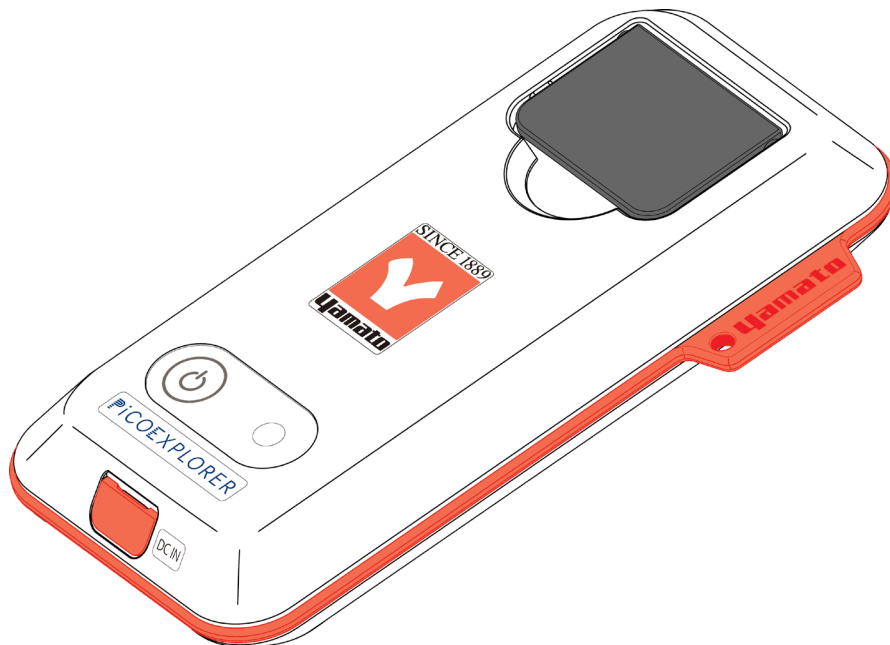

Yamato Scientific America, Inc.

Contents of this User's Manual may change without notice.

Due to design improvements, and/or specification and app changes,

PiCOEXPLORER™ configuration may change without notice.

All company names and products names in this manual are the property of their respective trademark holders.

Patent Pending

Supported Version
Android: 3.1.1
iOS: 2.0.8

Thank you for purchasing the PiCOEXPLORER™ PAS-110-YU photo absorbance sensor. This manual contains detailed descriptions, instructions for use, and specifications of this device. Please print out and store this manual in a safe place, and refer to as needed.

SAFETY NOTES

These safety notes are intended to help you use this device properly and safely. These notes contain essential and crucial instructions that must be followed at all times. Please read and understand these notes before reading the rest of the manual and guide.



This icon indicates a possible danger of loss of life or injury.





This icon indicates a possible danger of injury to personnel or physical damage.











This icon indicates important information concerning easy-to-make mistakes that can adversely affect operation and maintenance. Not following the instructions given could result in damage to the device.

 WARNING	<ul style="list-style-type: none"> ● Do not use the device near medical equipment. The radio waves emitted by wireless communication module could have an adverse effect on nearby pacemakers or electrical medical devices. ● Do not use near automatic doors, alarms, or other automatic electrical control devices. The wireless communication module could cause malfunctioning in these devices. ● Do not use any USB cables that have been damaged or deformed. Doing so could result in smoke, overheating, or fire. ● Carefully read and correctly follow the instruction in this user’s manual about the use of USB cables. Replace any cable that looks defective or damaged. ● Do not wash the device with water, or disassemble or tamper with it in any way. Doing so could result in electric shock, fire, or smoke. ● When powering the device thru a USB connector, use a PC with a limited-energy circuit USB output, or an AC adapter with a limited-energy circuit used to power PCs.
 CAUTION	<p>HANDLING OF PHOTO ABSORBANCE SENSOR</p> <ul style="list-style-type: none"> ● This device is for general analytic use. It was not designed for, nor should it be used for, medical diagnostic purposes requiring very high levels of reliability and/or accuracy. Yamato Scientific Co., Ltd. cannot be held responsible for any damages or liabilities resulting from the inappropriate use of this device for such purposes. ● To avoid eye injury, never look directly at the light source in the device. ● When connecting and removing the USB cable, do so carefully; do not jam the connector or yank the cord. ● Avoid dropping the unit or otherwise exposing to shocks or extreme forces. <p>HANDLING OF BATTERIES</p> <ul style="list-style-type: none"> ● Follow all instructions of this manual on the handling and use of dry-cell batteries. ● Use only the battery type specified (AAA type). Other types may damage the unit. ● Insert batteries properly, matching the plus and minus ends to the equivalent connections inside the unit. ● When replacing batteries, always replace all 3 batteries together. ● Keep batteries out of the hands of small children. ● If the unit will not be used for some time, remove the batteries before storage. Leaking batteries can cause severe damage.

SAFETY NOTES

 <p>CAUTION</p>	<p>HANDLING OF BATTERIES</p> <ul style="list-style-type: none"> ● Do not expose batteries to heat or toss into open flames. ● For the sake of the environment, dispose of used batteries responsibly and in accordance with local regulations. ● The batteries that come packaged with the unit were inserted only for device testing purposes. They may not last long; replace them as soon as possible.
 <p>CAUTION</p>	<p>HANDLING OF A BLUETOOTH DEVICE</p> <ul style="list-style-type: none"> ● This is a Bluetooth low-energy compatible device. It cannot be connected with any other wireless communication protocol. ● This device has been certified as having the proper wireless system for low-power electronic communication. Do not remove the label of certification from the device. It is against the law to tamper with the device by disassembling, and/or altering operation. Doing so may result in criminal prosecution. ● This device communicates using a 2.4GHz frequency range. This range is also used by the following wireless transmitters: commercial, scientific, and medical devices and other similar devices, wireless transmitters used to detect moving object on factory lines (which require licensing), low-power wireless transmitters which do not require licensing, and amateur wireless transmitters, all of the above designated herein as “other wireless transmitters”. Before using, make sure there is no such wireless transmitter in the vicinity which could cause interference. If you find that the operation of this device near another wireless transmitter is causing interference, increase the distance between the devices or if possible, turn off the other device.
 <p>IMPORTANT</p>	<ul style="list-style-type: none"> ● Do not use in areas with high levels of dust, oil smoke, steam, damp, or high heat. ● If the unit gets wet or submerged in liquid, immediately turn off and consult your vendor. ● Dirt and other contaminants in the measuring chamber can cause erroneous readings. Before using, make sure the measuring chamber is clean; if not, carefully wipe away all contaminants with a cotton swab or gauze/soft cloth. ● Do not swing the device by its strap. This could damage/loosen the water-resistant packing in the device. ● You may be subjected to penalties to use this device in the country not authorizing the device usage due to its restrictions on wireless use. ● Communications errors or reductions in communication speed may result when using the device in the proximity of a 2.4GHz wireless LAN. Keep the device and the communicating tablet as close to each other as possible to avoid this.

CONTENTS

SAFETY NOTES	2
DEVICE FEATURES	5
HARDWARE PACKAGE	5
HARDWARE COMPONENTS	6
BATTERY INSERTION / APP. INSTALL	7
TAKING MEASUREMENTS	8
1. Using the Top Screen	10
 2. Wireless Connection	11
 3. Graphing the Standard Curve	13
3-1 Measurement Wavelength Range Selection	13
3-2 Blank Measurement	14
3-3 Measuring Known Concentrations	16
3-4 Graphing the Standard Curve	18
3-5 Standard Curve Loading Function	19
3-6 Unit Maintenance Function	20
3-7 Other Functions	23
 4. Taking Measurements	25
4-1 Manual Measurement	26
4-2 Timed Measurement (Simplified Kinetic Measurement)	27
 5. Turbidity Measurements	29
 6. Displaying Previous Measurements	32
7. Saving Data (to a CSV file)	34
OTHER SCREENS	
 8. Info Screen	35
 9. Maintenance Screen	36
 10. Help Screen	38
MAINTENANCE	39
TROUBLESHOOTING	40
WARRANTY AND AFTER-SERVICE	42
SPECIFICATIONS	43
LAWS AND REGULATIONS	44

SAFETY NOTES

DEVICE FEATURES
HARDWARE PACKAGE

HARDWARE
COMPONENTS

APP INSTALL
BATTERY INSERTION

TAKING
MEASUREMENTS

OTHER SCREENS

MAINTENANCE

TROUBLE-
SHOOTING

WARRANTY AND
AFTER-SERVICE

SPECIFICATIONS

LAWS AND
REGULATIONS

DEVICE FEATURES

- The PICOEXPLORER™ is a portable absorptiometer that uses a white LED as its light source.
- You can verify PICOEXPLORER™ measurement results on your Smartphone or tablet PC by downloading a special application that uses Bluetooth communication to check the results of measurement.
- The high sensitivity yet extremely compact design of this device is the result of breakthrough Silicone Optical Technology (SOT™).
- Battery-driven and portable.
- Measurements can be taken directly from unopened PCR tubes, helping to prevent contamination.

HARDWARE PACKAGE

The standard package includes:

- (1) PAS-110-YU Unit 1
- (2) Quick Start Guide (includes warranty)..... 1

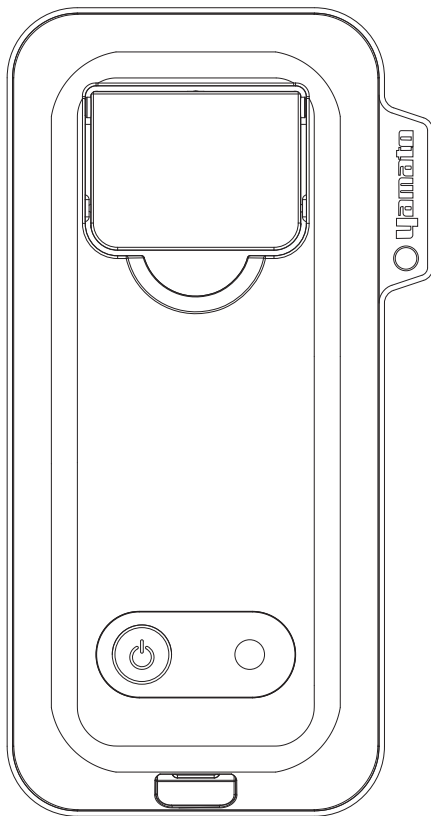

PAS-110-YU Unit

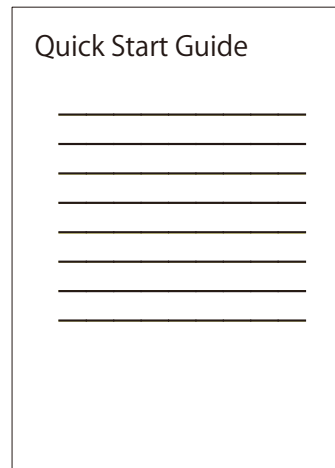

Quick Start Guide (includes warranty)

HARDWARE COMPONENTS

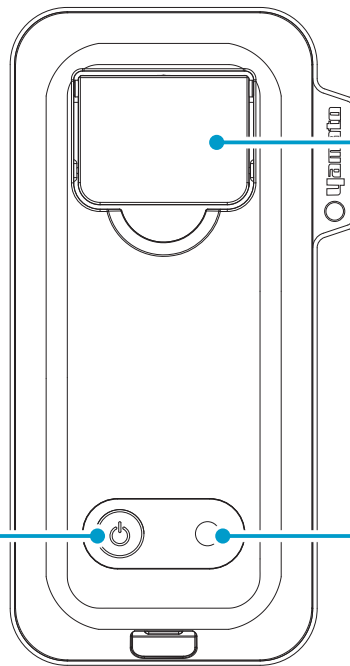

Power Switch
Turn unit on and off.

Measurement Chamber Cover
Open this cover to insert PCR tube for sample measurement.

Status Light

- Steady Red: check battery level
- Steady Purple: powered and connected via Bluetooth Low Energy
- Blinking Red: Low voltage*
- Blinking Blue: measurement in progress

* Some batteries may fail without first blinking.

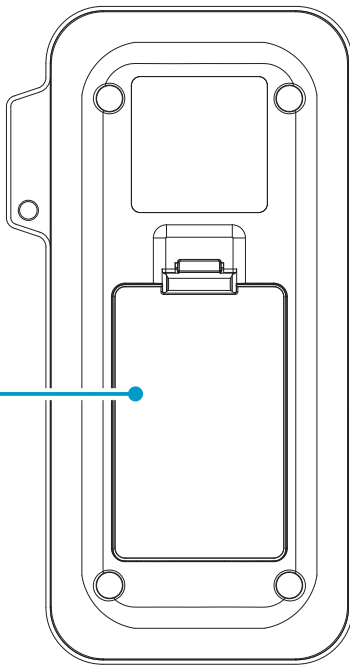

Battery Cover
Open to insert batteries.

USB Interface Connector (micro USB)
For connection with a USB cable. Can be used to supply power instead of batteries. Not a data communication channel.

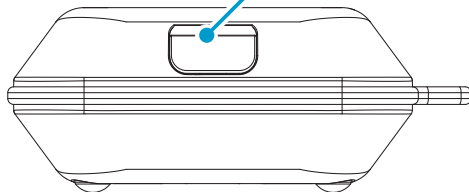

BATTERY INSERTION

·The unit does not come with ready-to-use, fully charged batteries.

Batteries Needed: 3 AAA Type Dry-Cell Batteries



Use only AAA type batteries. Use of other types may damage the unit.

Follow the 3 steps below when replacing batteries.

1. Open the battery cover on the back side of the unit.
2. Insert batteries, aligning the plus and minus (+ and -) ends of the batteries with the plus and minus markings on the inside of the battery case.
3. Close the battery cover.

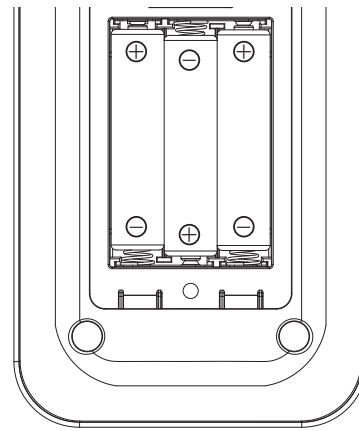

Make sure battery cover is securely fastened. A loose cover may allow water to seep into the unit and cause damage.
Before opening the cover, wipe off any liquid on the outside to prevent see page and possible damage.

APP INSTALL

Please download and install the free app via Google Play or App Store.

App download procedure

1. Please open Google Play or App Store.
2. Type "PAS110" in the search box to use the search.
3. Tap on the left icon and confirm the content. Tap on "install" or "obtain" and follow the instructions to install the app.
4. Wait until the "download and installation are complete." Tap on "open" to start the app.

TAKING MEASUREMENTS

Follow the procedure outlined below for taking basic measurement readings.

1. Turn on unit power. The status light will turn red ●.
 - * If battery level falls too low, the red light will begin blinking.
2. Open the measurement chamber lid and set PCR tube into the measurement chamber. Firmly close the lid.

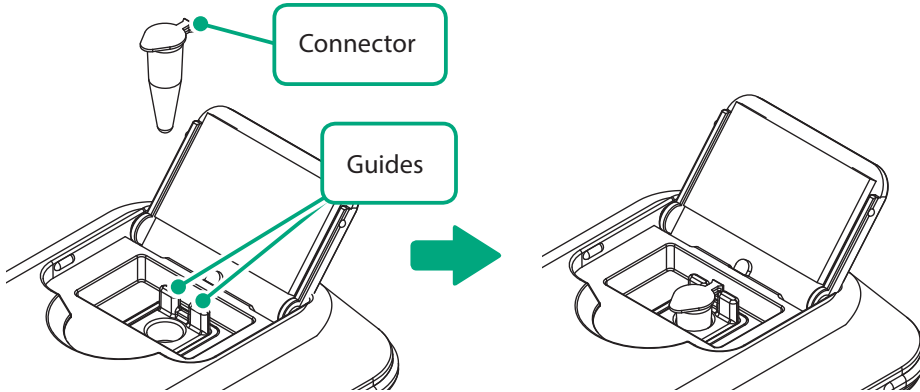

Note that the tube lid connector should fit snugly between the two guide projections at the back of the chamber.

 CAUTION	Do not let any sample liquid from the PCR Tube spill into the unit. This could damage the optical unit.
-------------	---

3. Launch the tablet application (PAS-110) by tapping the icon. **Page10, 1. Using the Top Screen.**
4. Make BLE connection. **Page11, 2. Wireless Connection.**

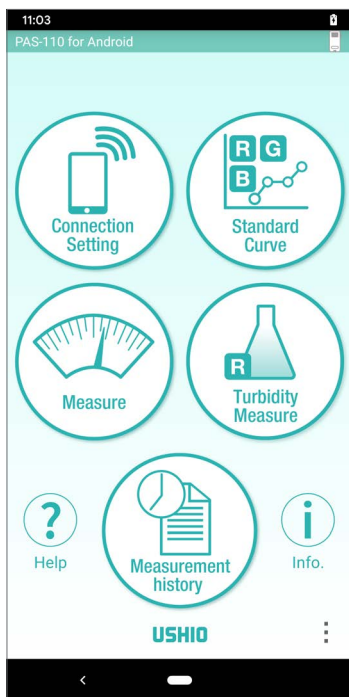

Top Screen

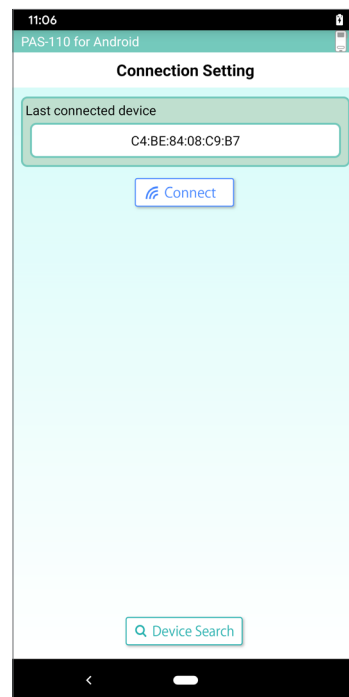

Connection Setting Screen

TAKING MEASUREMENTS

5. Draw a standard curve.

Page13, 3. Graphing the Standard Curve

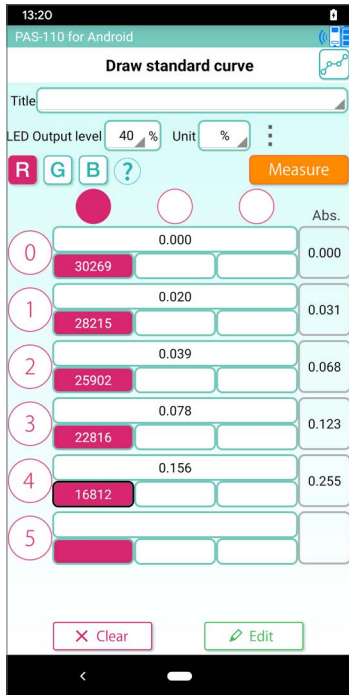

Drawing Standard Curve Screen

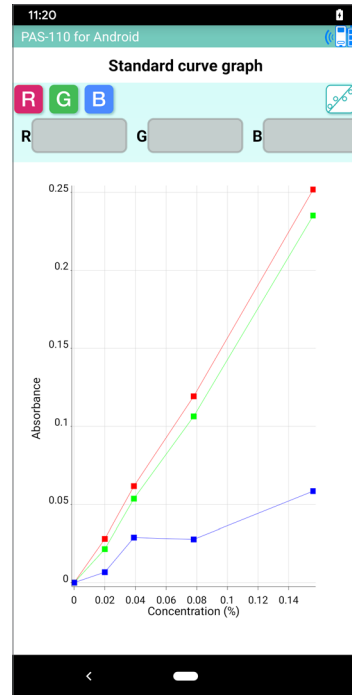

Standard Curve Graph Screen

6. Measure concentration of the unknown sample.

Page25, 4. Taking Measurements

No.	Concentration	Date
1	0.034	2019/11/22 11:25
2	Out of range	2019/11/22 11:25
3	0.017	2019/11/22 11:25
4	0.078	2019/11/22 11:25
5		
6		
7		
8		

Concentration Measurement Screen

7. Check previous measurements.

Page32, 6. Displaying Previous Measurements

No.	Concentration	Date
1	0.029	2019/05/28 10:54
2	0.036	2019/05/28 10:55
3	0.133	2019/05/28 10:55
4	0.128	2019/05/28 10:55
5		
6		
7		
8		

Measurement History Screen

TAKING MEASUREMENTS

1. Using the Top Screen

The top screen displays the following buttons.

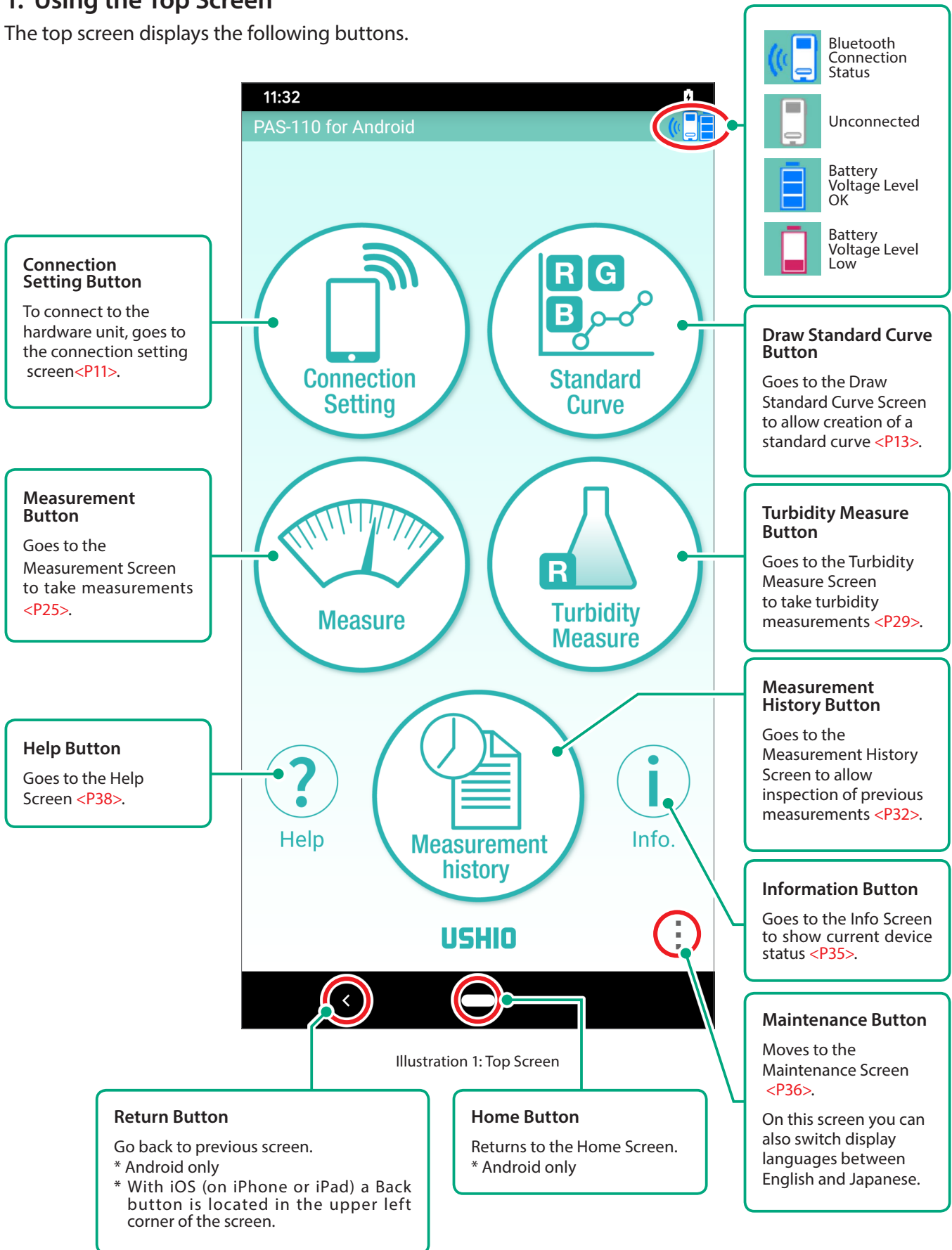

Illustration 1: Top Screen



TAKING MEASUREMENTS

2. Wireless Connection

Tap the **Connection Setting Button** on the top screen to move to this screen (Illustration 2-1).

* Make sure that Bluetooth functionality is enabled on your Smartphone or tablet PC.

 If you are using an Android device, it is necessary to turn on access permission to the location of the app and location service of the device. When these are OFF, you can not connect to the device.

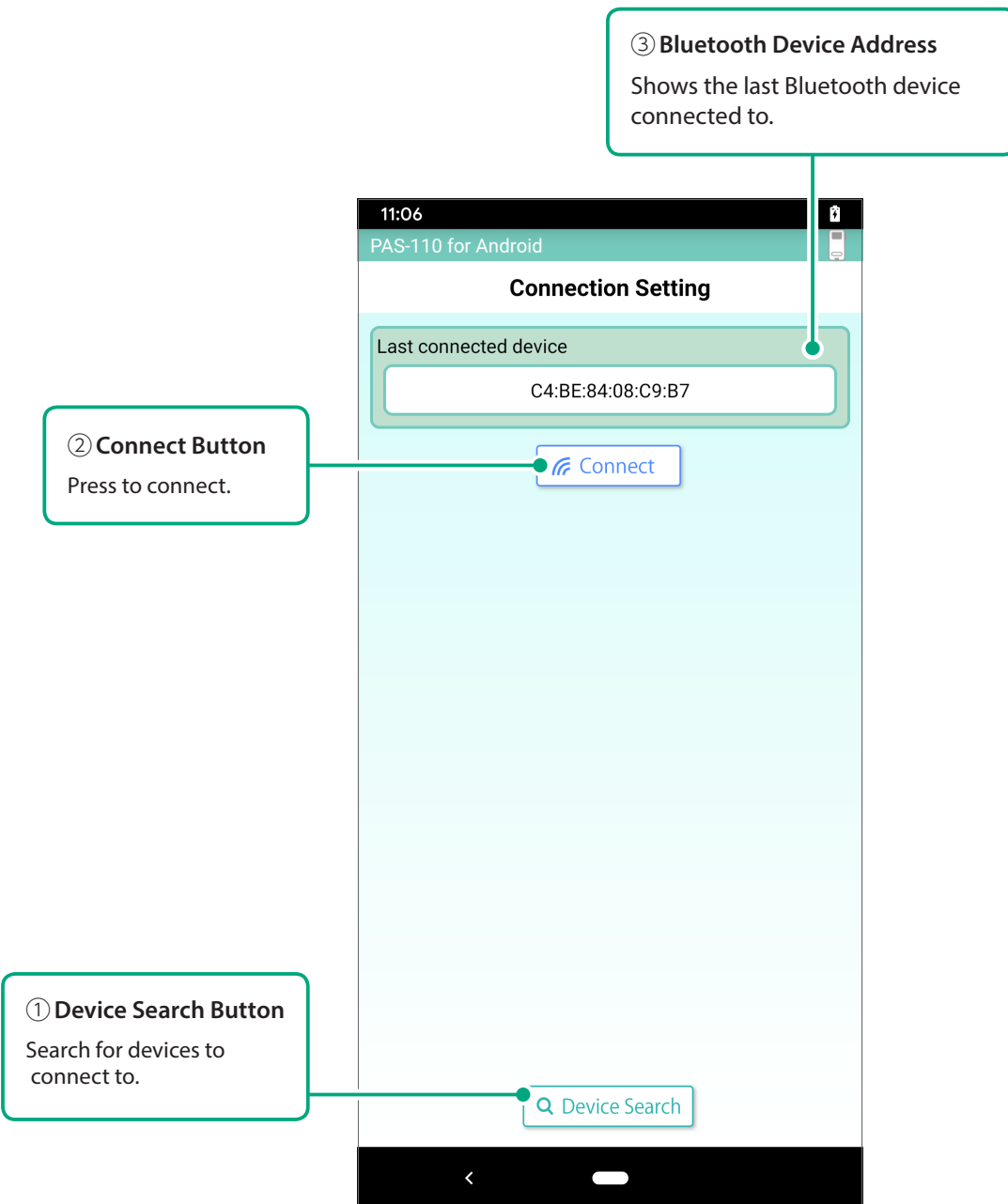

Illustration 2-1: Connection Setting Screen

TAKING MEASUREMENTS

- Tap ① **Device Search Button** to search for photo absorbance sensor unit. If not detected, turn the photo absorbance sensor off and on, then tap the ① **Device Search Button** again. If the photo absorbance sensor is found, its Bluetooth device address will be displayed as shown in Illustration 2-3.

* (iOS only) "PAS-110" is displayed for the first time. The address will be displayed from the second time.

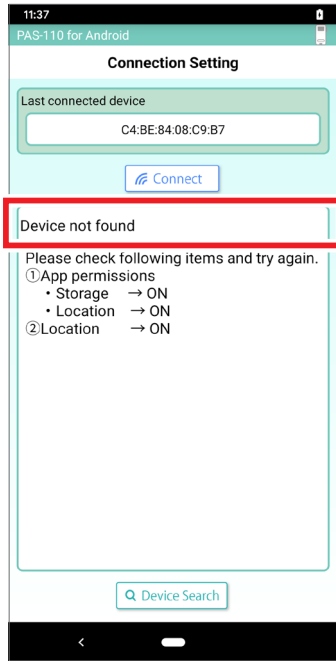

Illustration 2-2:
Device Address Not Found



Illustration 2-3:
Device Address Found

- Tap the device address that you wish to connect to.
The background color of the address will change, indicating selection.(Illustration 2-4).

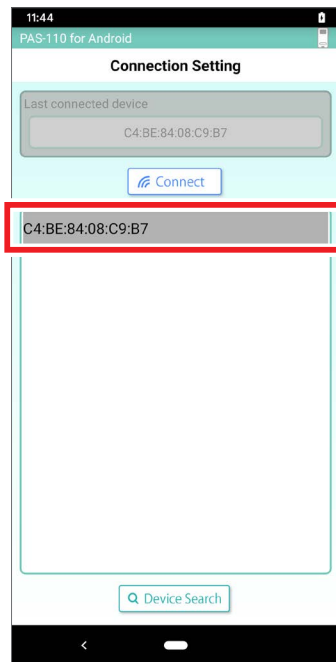

Illustration 2-4: Device Address Selected

- Tap the ② **Connect Button** to begin connecting.
- Once the connection is established, tap the **Return Button** to return to the top screen.

TAKING MEASUREMENTS

3. Graphing the Standard Curve

When drawing a standard curve, first prepare a set of samples of known concentration.

The procedure is as follows:

1. Measurement wavelength range selection;
2. Blank measurement;
3. Measure known concentration sample data;
4. Verify the standard curve graph.

Before beginning the procedure, be sure to tap the **Clear Button** (3-7 (1)) to clear previous data.

Tap the **Standard Curve Button** on the top screen to move to the Draw Standard Curve Screen (Illustration 3-1).

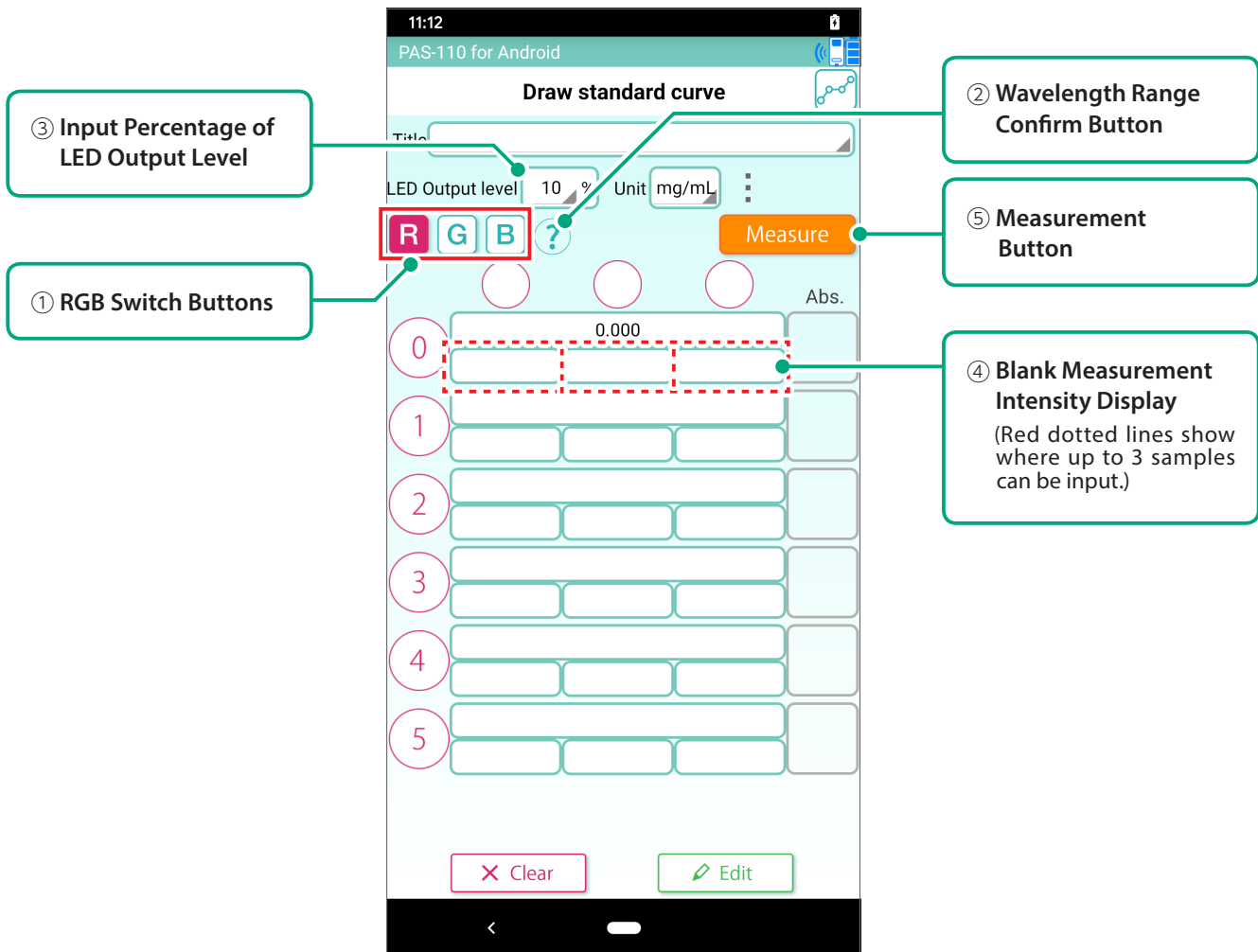

Illustration 3-1: Draw Standard Curve Screen ①

3-1. Measurement Wavelength Range Selection

- (1) Select the wavelength range for the sample to be measured using the ① **RGB Switch Buttons**.
- (2) You can check the Maximum absorption wavelength and wavelength range by tapping the ② **Wavelength Range Confirm Button** of hint icon.

TAKING MEASUREMENTS

3-2. Blank Measurement

- (1) Set the sample for determining the blank concentration into the measurement chamber.
- (2) The ③ LED output level is 10% by default, but other levels can be selected. Select the LED output level as appropriate according to blank measurement timing.

We recommend first taking a measurement at the 10% default level, and then making adjustments later
 < Page 15(5)>.

Tap the ③, the scrolling list (Illustration 3-2) is displayed. Then select the number and tap the OK button.

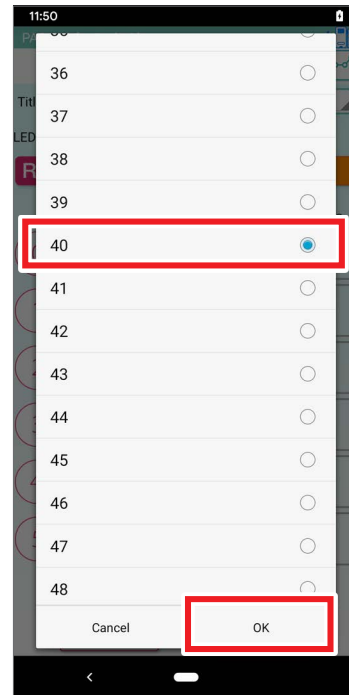

Illustration 3-2:
Scrolling list of LED output levels

- (3) Do blank measurement. When you tap the ④ Blank Measurement Intensity Display, a black frame appears as shown in Illustration 3-3.

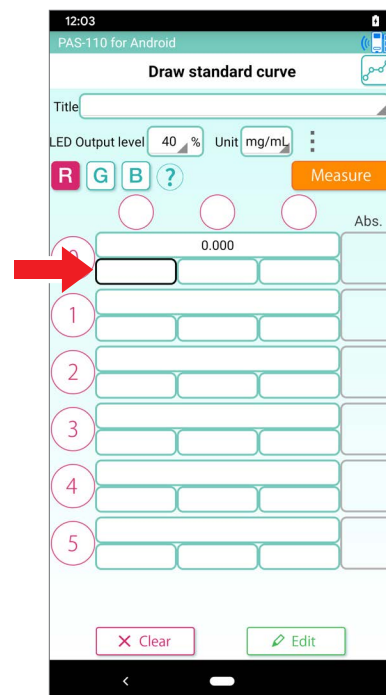

Illustration 3-3:
Baseline data input box selected

TAKING MEASUREMENTS

- (4) Blank measurement begins when you tap the ⑤ **Measure Button**. The measured blank intensity is displayed in the black frame, and the absorption value (0.000) is displayed in the frame on the right (Illustration 3-4).

At this time R, G, and B data are simultaneously measured. When measurement is finished, the value will be displayed in white font. This data will be used to make the graph of the curve < Page 18 > .

*The measured intensity indicates the amount of light passing through the sample. Absorption is calculated based on the blank measurement intensity and the measured intensity of the sample.

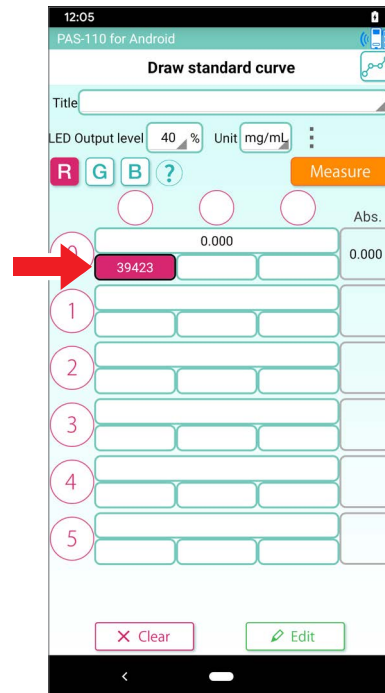

Illustration 3-4:
Measured value displayed in white font

- (5) The blank measurement intensity should fall in the range of 30000 to 60000. If the value is lower, raise the LED output level <Page 14(2)>. Also, tap the ① **RGB Switch Buttons** and make sure that the blank measurement intensity values for R, G, and B are not all 65535. Values of 65535 indicate that the measurement data is saturated, so absorption cannot be properly measured.
- (6) If the measured intensity is 65535, return to (2), lower the LED output level, and then measure again. When the level is changed, a prompt like that shown in Illustration 3-5 is displayed to request confirmation that data is to be cleared; select "Yes".

This completes blank measurement.

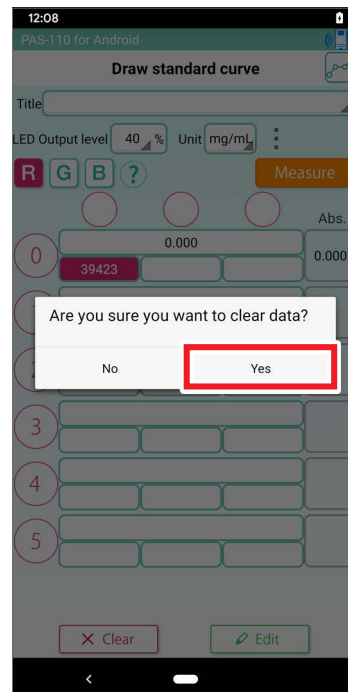

Illustration 3-5:
Data Clear Confirmation Notice

TAKING MEASUREMENTS

3-3. Measuring Known Concentrations

Using the same Draw Standard Curve Screen (Illustration 3-6), measure a series of samples of known concentrations.

- (1) Set a sample into the measurement chamber of the photo absorbance sensor.

The screenshot shows the 'Draw standard curve' screen with the following callouts:

- ① Concentration Units Select Button**: Points to the 'Unit' dropdown menu.
- ② Known Concentration Input Area**: Points to the input fields for concentrations 1 through 5. Note: (Always enter concentration values in ascending order in Input Areas 1 → 5.)
- ③ Known Concentration Sample Measurement Intensity Display**: Points to the intensity values (e.g., 30269, 28215) inside the dotted red lines. Note: (Up to 3 measurements can be made on the sample, displayed inside the dotted red line.)
- ④ Measurement Button**: Points to the orange 'Measure' button.
- ⑤ Absorbance Value Display**: Points to the absorbance values (e.g., 0.000, 0.031) in the right column. Note: (Blue outline: values multiplied by an absorbance multiplier)
- ⑥ Standard Curve Graph Display Button**: Points to the graph icon in the top right corner.

Input Area	Known Concentration	Sample Measurement Intensity	Absorbance Value
0	0.000		0.000
1	0.020	30269	0.031
2	0.039	28215	0.068
3	0.078	25902	0.123
4	0.156	22816	0.255
5		16812	

Illustration 3-6: Draw Standard Curve Screen ②

TAKING MEASUREMENTS

- Tap the ① **Concentration Units Select Button** to choose the units in which the measurements will be made (Illustration 3-7). Tap the OK to confirm.

Initially, four unit variations are registered (mg/mL, $\mu\text{g}/\text{mL}$, ng/mL, and %). See <Pages 20-22> for how to add new units.

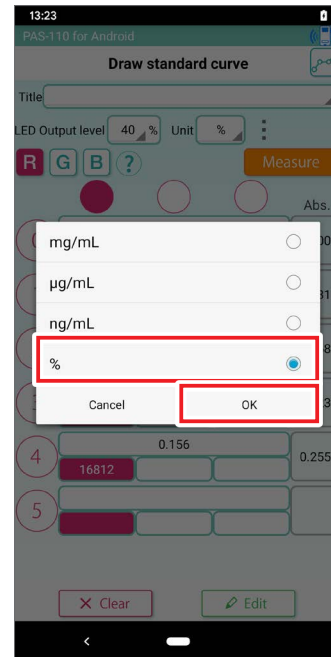

Illustration 3-7:
Selection of Concentration Units

- Tap the ② **Known Concentration Input Area** and input the known concentration value.
- Tap the ③ **Known Concentration Sample Measurement Intensity Display** to display the black frame.
- Tap the ④ **Measure Button** to begin measurement. The measured value will be displayed in white font.
- The ⑤ **Absorbance Value Display** will show the actual calculated absorbance.
- When this measurement is finished, remove the current sample in the photo absorbance sensor, place the next sample in, return to step (1), and repeat the process.
- When all the samples have been measured, tap the ⑥ **Standard Curve Graph Display Button** and confirm the graphed results. The values displayed in white font (Illustration 3-8) are the ones displayed on the standard curve <Page 18>. If you wish to a measurement from the graph, remove it by a long press on that data's display box.
- When you return to the top screen and proceed to "Measure", the unknown sample is measured using the created standard curve <Page 25>. The standard curve data is stored together with the measurement data <Page 34>.

* The standard curve cannot be saved by itself.

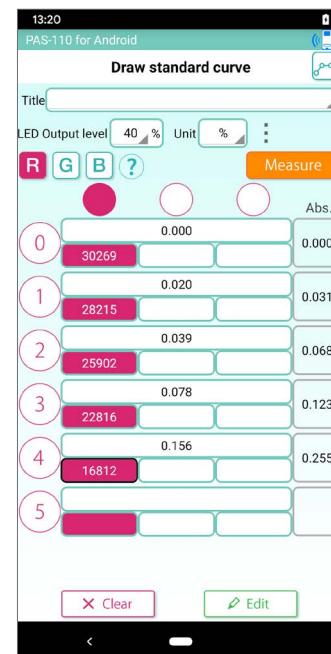

Illustration 3-8:
Results of Standard Curve
Measurement Procedure

TAKING MEASUREMENTS

3-4. Graphing the Standard Curve

Here we explain how to check the graph of created calibration curve.

- (1) When you tap the **Standard Curve Graph Display Button**, a graph appears indicating concentration on the horizontal axis and absorption on the vertical axis (Illustration 3-9).

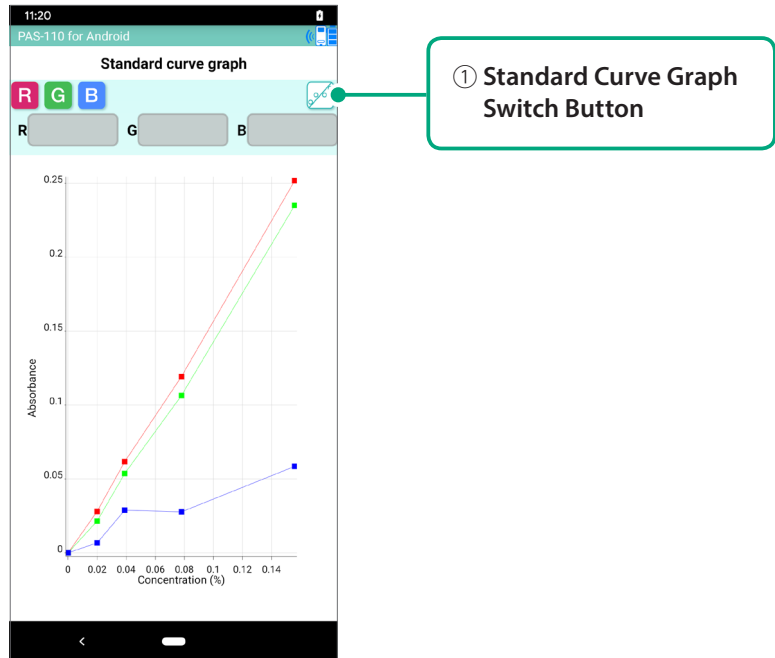

Illustration 3-9:
Standard Curve Graph Screen

- (2) When you tap the ① **Standard Curve Graph Switch Button**, graph displayed changes to show a least squares linear regression line for the data (Illustration 3-10). Also, the coefficient of determination (R^2) is displayed at ②. This value indicates the linearity of the data how well the least squares line fits the data is indicated by this value.

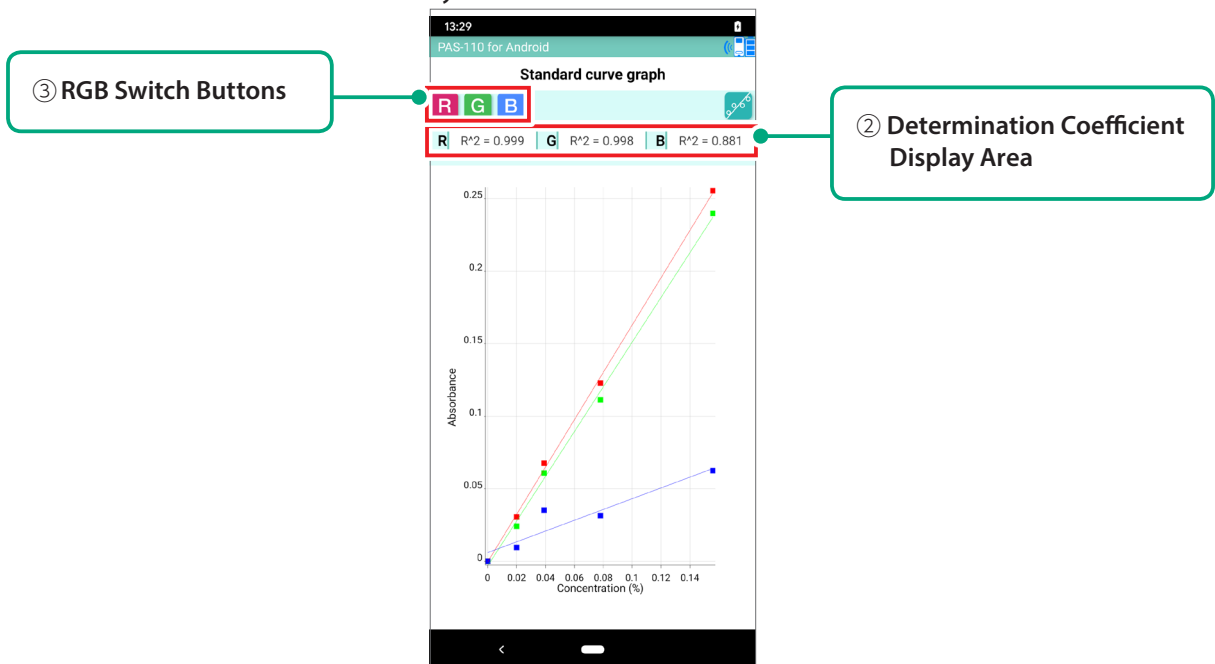

Illustration 3-10:
Fitting a Line to the Measured Data Points

- (3) All of the RGB graphs appear in the initial display. Graph display of each of the RGB graphs can be switched on or off using the ③ **RGB Switch Buttons**.

TAKING MEASUREMENTS

3-5. Standard Curve Loading Function

Here we explain how to recall stored standard curve data that was used during earlier measurement for reuse.

- (1) Tap the ① **Select Standard Curve Data** to display the standard curve data selection screen.

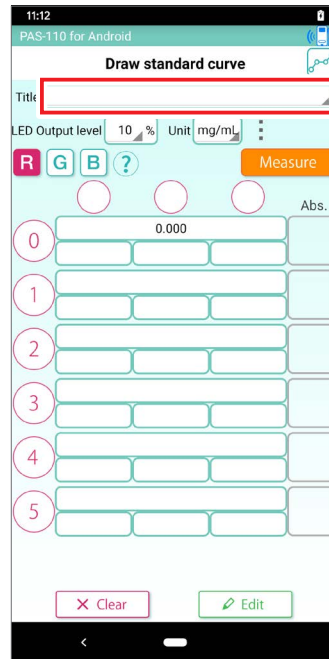

- (2) Select the standard curve data and tap the ① **Load button**. The data loaded from the CSV file is displayed on the standard curve creation screen.

If the added unit is unavailable after saving the standard curve data, "mg/mL" will be selected. If you add the unit again on the unit maintenance screen, the unit will be available.

* If you load a standard curve created on another device, there is possibility not to perform accurate measurement.

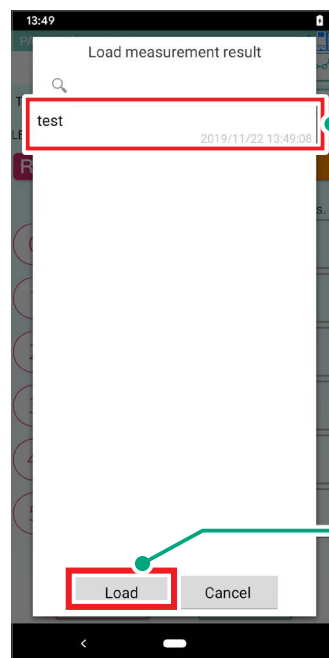

3-6. Unit Maintenance Function

Here we show how to add new units in addition to the ones that are registered by initial setting (mg/mL, µg/mL, ng/mL, and %).

How to add a unit

- (1) Tap the **Unit Maintenance Button** on the standard curve creation screen to display the unit maintenance screen.

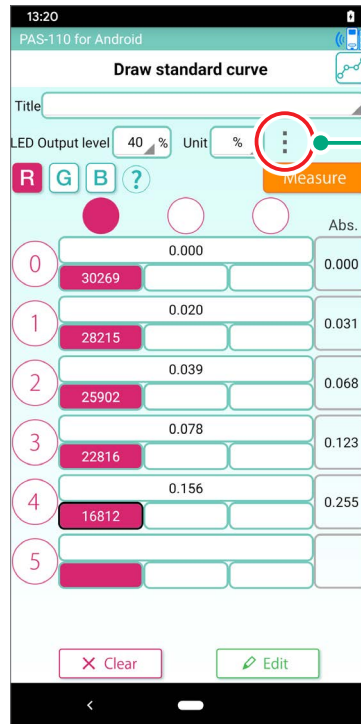

Unit Maintenance Button

- (2) Tap the **Add Line Button** on the unit maintenance screen to display the input line (maximum 10 lines).

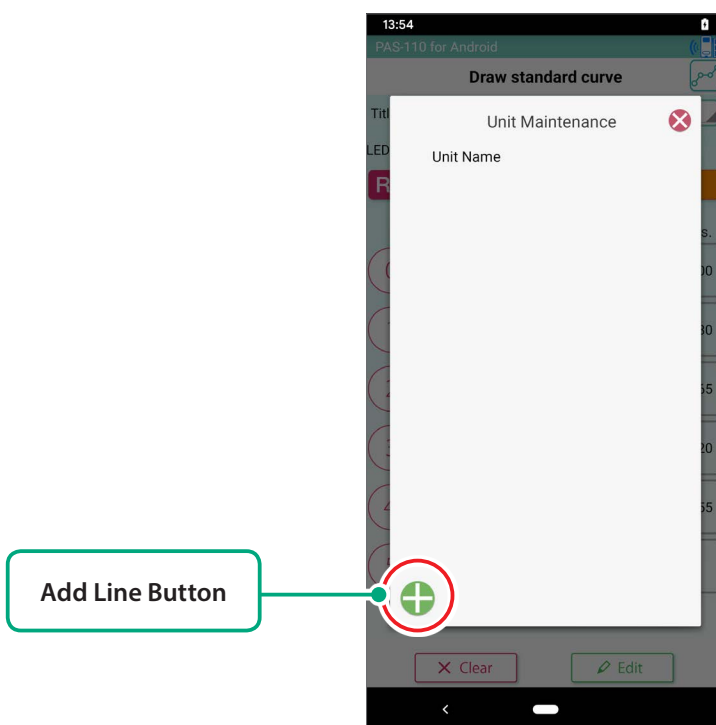

Add Line Button

TAKING MEASUREMENTS

(3) When you enter a unit, it is added to the unit selection list on the standard curve creation screen.

* Special characters (such as μ) cannot be entered.

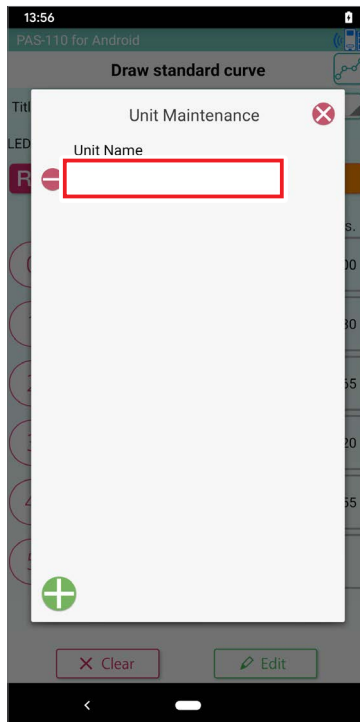

(4) You can select the added unit by tapping it.

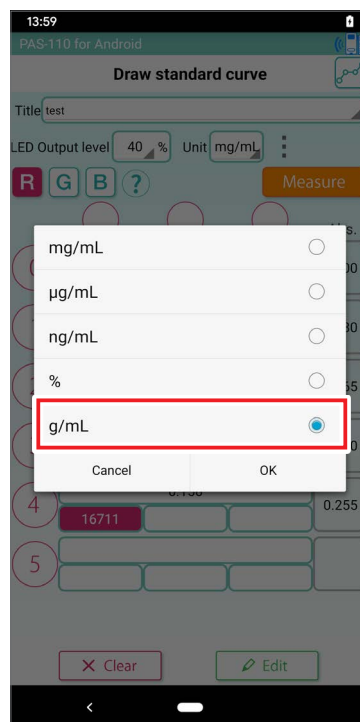

TAKING MEASUREMENTS

How to delete a unit

(1) Tap the **Unit Delete Select Button** on the unit maintenance screen to display the **Delete Button**.

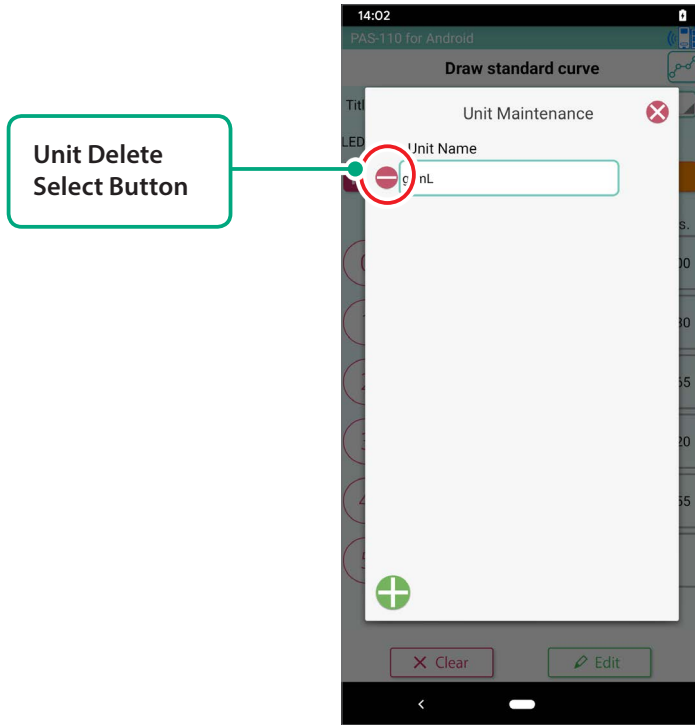

(2) When you tap the **Delete Button**, the line is deleted, and it is also removed from the unit selection list on the standard curve creation screen.

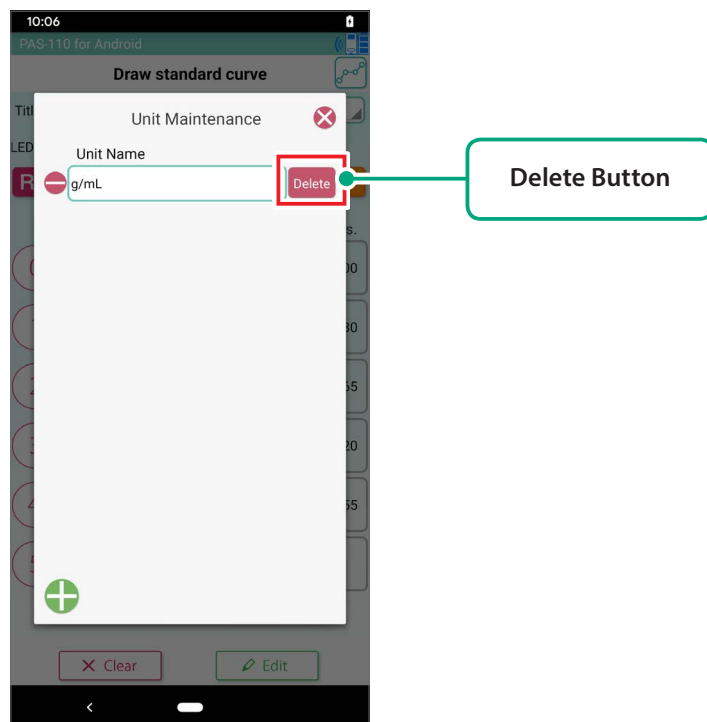

TAKING MEASUREMENTS

3-7. Other Functions

This section describes miscellaneous functions of the app.

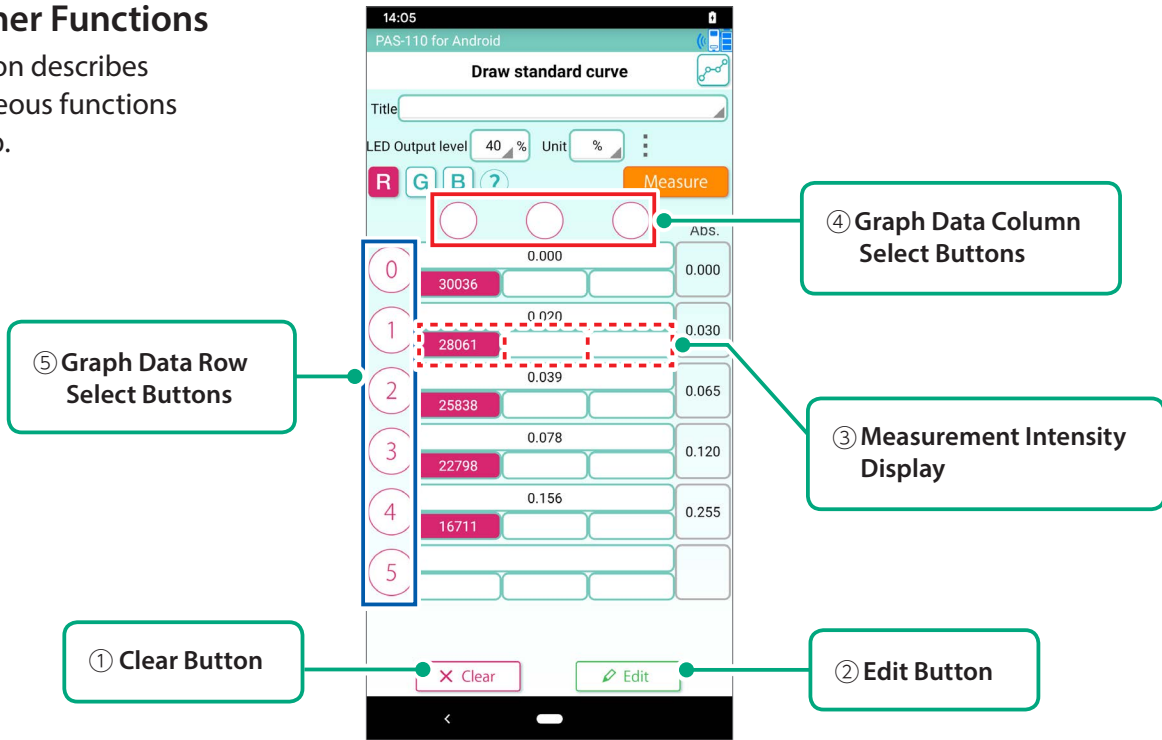

Illustration 3-11:
Draw Standard Curve Screen ③

(1) Data Clear Function

Tap the ① **Clear Button** to clear all data.

(2) Data Edit Button

Tap the Known Concentration Input Area, then the ② **Edit Button** to directly edit the data values (Illustration 3-12).

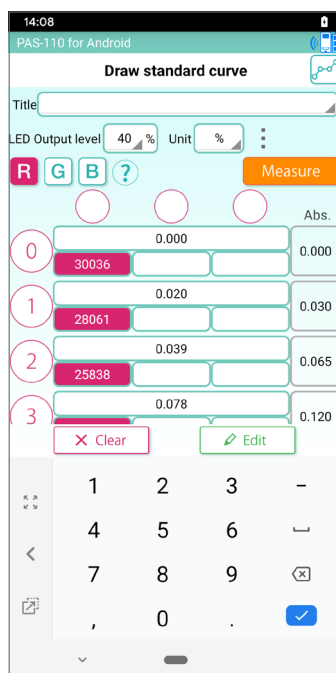

Illustration 3-12:
Directly Editing Data Values

TAKING MEASUREMENTS

(3) Graph Data Column Selection

You can select the measurement intensity data column used for calculating absorption by tapping the ④ **Graph Data Column Select Buttons** (Illustration 3-13).

With the initial setting, absorbance based on average measured intensity is displayed. Using this function, absorbance can be calculated based on individual values of measured intensity.

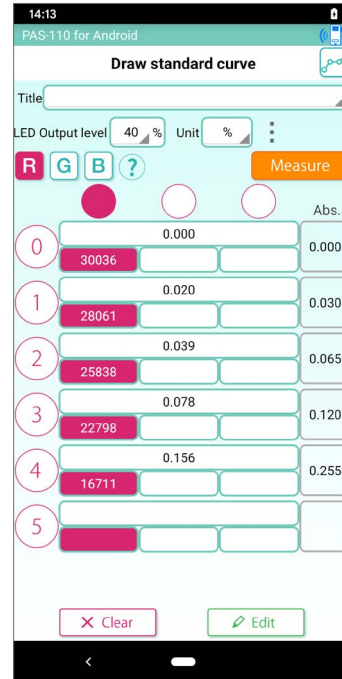

Illustration 3-13:
Entire Data Column Selected

(4) Graph Data Row Selection

You can select the row of data to be applied to the standard curve graph by tapping the ⑤ **Graph Data Row Select Buttons** (Illustration 3-14).

With the initial setting, all data rows are applied to (plotted in) the standard curve graph. Using this function, you can select the row of data to be applied to the standard curve graph.

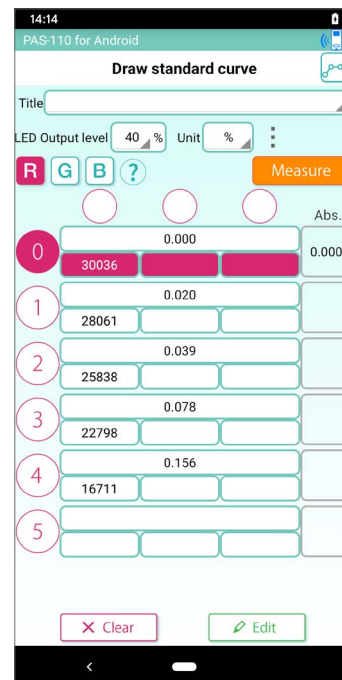

Illustration 3-14:
Entire Graph Data Row Selected



TAKING MEASUREMENTS

4. Taking Measurements

Measure an unknown sample based on the standard curve. Unknown samples can be measured after creating a standard curve <Pages 13-18> or recalling a previously prepared standard curve <Page 19>. Tap the **Measure Button** on the top screen to move to the Measurement Screen (Illustration 4-1).

The screenshot shows the 'Measure' screen of the PAS-110 for Android. It includes a title input box, LED Output level (40%), a units selection dropdown (currently showing '%'), RGB switch buttons (R, G, B), a 'Measure' button, a table of measurement history, and 'Export CSV' and 'Clear' buttons at the bottom.

No.	Concentration	Date
1	Out of range	2019/11/22 13:48
2	0.033	2019/11/22 13:48
3	0.078	2019/11/22 13:48
4		
5		
6		
7		
8		

Illustration 4-1: Measurement Screen



TAKING MEASUREMENTS

4-1. Manual Measurement

- (1) Set the unknown sample in the measurement chamber.
- (2) Enter the Title of the run into the ① **Title Input Box**
- (3) Tap the ② **Measure Button** to measure the unknown sample. "Out of range" is displayed for values that fall outside the range of the standard curve. Although the application displays "Out of range," absorbance and intensity are displayed on the computer following CSV output.
- (4) With the initial setting, the measured valued (white) is displayed based on interpolation of the standard curve between two points, but upon tapping the ③ **Standard Curve Switch Buttons**, display switches to the measurement value (green) based on the least squares fit line.
- (5) You can check the standard curve graph by tapping the ④ **Standard Curve Graph Button**. Measured values of unknown samples are plotted on the standard curve graph as open circles.
- (6) Tap the ⑤ **CSV File Button** to output the data values to a CSV file.

Page 34, 7. Saving Data (to a CSV file).

Saved data can be rechecked at any time from the History Screen.

The following single-byte characters cannot be entered.

Android [,][][?][>][<][/][¥][:]["][*][\]
 iOS [,][][?][>][<][/][¥][:]["][*][\][_]

- (7) Units for the measurement value of the unknown sample can be selected from among three options in the ⑥ **Unit Selection Area** (Illustration 4-2).
 - Concentration (mg/mL in the figure below): The concentration is calculated from absorbance based on the prepared standard curve.
 - RGB: This is the measurement value prior to conversion to absorbance.
 - ABS: This is the absorbance value prior to conversion to concentration.

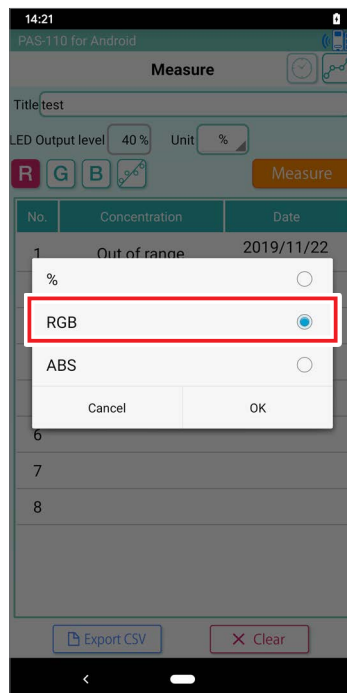

Illustration 4-2:
Concentration Units Selection



TAKING MEASUREMENTS

- (8) Display can be switched to measurement results for each of the RGB wavelength modes (Illustration 4-3) using the ⑦ RGB Switch Buttons.



Illustration 4-3:
Example: Selected G Data Values Displayed.

4-2. Timed Measurement (Simplified Kinetic Measurement)

This function allows automatic timed measurement of an unknown sample without using a standard curve. For example, by using this function you can track the change in state of an unknown sample over time, or measure the same sample more than once while automatically increase the measurement number n.

* Measurement unit is limited to intensity value (RGB).

How to start

- (1) Set timed measurement ON <Pages 36-37> and enable the ⑧ Timed Measurement Button.
- (2) Tap ⑧ Timed Measurement button. Timed Measurement setting screen pops up.
- (3) In the Timed Measurement setting screen, set the measurement interval and the measurement duration. The example at right shows the settings for continuous measurement at 2-second intervals for 60 seconds.

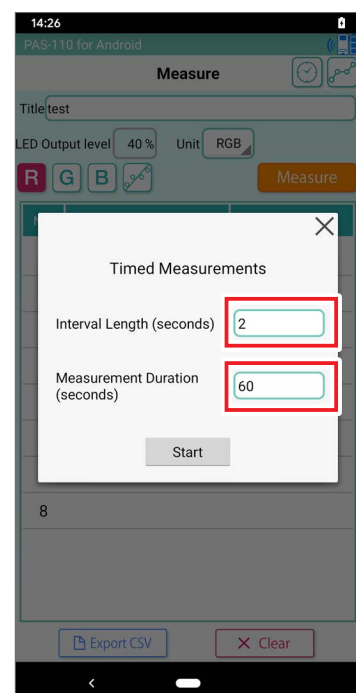

TAKING MEASUREMENTS

(4) Timed measurement starts immediately when you tap the **Start Button**.

* Do not tap "Back" "Home" button or push the power button during the Timed Measurement. The measurement will be stopped.

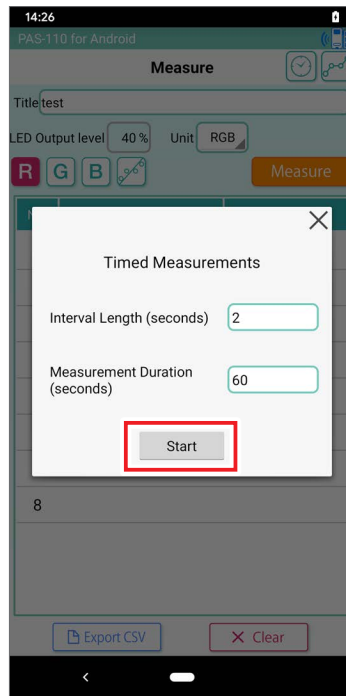

How to stop

Tap the ⑧ **Timed Measurement Button** while timed measurement is in progress opens the Timed Measurements screen. Tap the **Stop Button** interrupts timed measurement.

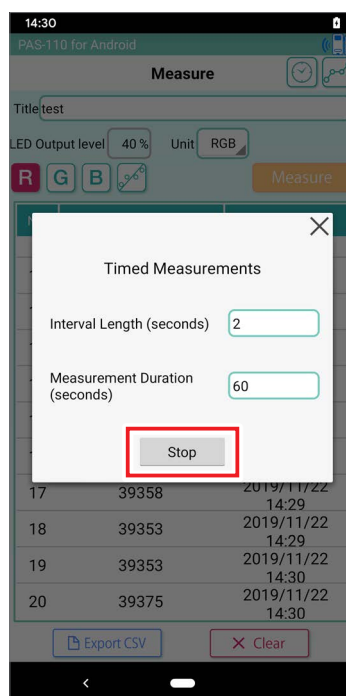

5. Turbidity Measurements

The turbidity of the solution is measured as the O.D. (Optical Density) of the R sensor.

The procedure is as follows: (Example of E.coli culture)

1. Run calibration;
2. Set the blank solution (Culture solution without E.coli), run blank measurement;
3. Set the cultured E.coli and measure.

Tap the **Turbidity Measure Button** on the top screen to move to the Turbidity Measurement Screen (Illustration 5-1).

The screenshot shows the 'Turbidity Measure' screen with the following elements and callouts:

- ⑤ Title Input Section:** A text input field labeled 'Title'.
- ① Calibration Button:** A red button labeled '① Calibration'. Legend: Red : unexecuted, Blue : executed.
- ② Blank Measurement Button:** A light red button labeled '② Blank'. Legend: Red : unexecuted, Blue : executed. Note: Operation is possible after the Calibration.
- ③ Measurement Button:** An orange button labeled '③ Measure'. Note: Operation is possible after the Blank Measurement.
- ⑥ Conversion Factor Input Section:** A field labeled 'Conversion Factor' with the value '1.00' and a red warning icon '<P31>'. Note: Conversion Factor.
- ④ CSV File Button:** A blue button labeled 'Export CSV'.
- ⑦ Clear Button:** A pink button labeled 'Clear' with a red 'X' icon.

Technical details on the screen: Max Wavelength : 615nm, Wavelength Range : 575~660nm.

No.	O.D.	Date
1		
2		
3		
4		
5		
6		
7		
8		
9		
10		

Illustration 5-1: Turbidity Measurement Screen

TAKING MEASUREMENTS

5-1. Turbidity Measurements

- (1) Tap the **Turbidity Measure Button** on the top screen.
- (2) Tap the Calibration Start. (Illustration 5-2)

The device automatically adjusts the LED output. It takes about 10 seconds.

<p>CAUTION</p>	<p>If calibration fails, check that there is no sample or foreign matter with high absorbance in the measurement chamber.</p> <p>If it fails repeatedly, there may be a device failure. Please turn off the power and contact a customer support desk.</p>
----------------	--

- (3) Set the blank solution to the reference, tap the Blank Measurement Start. (Illustration 5-3)
- (4) Set the sample and tap the ③ **Measure Button**. (Illustration 5-4)

The O.D. of the sample is displayed. If you have multile samples, you can repeat measurement in the same way.

- (5) Tap the ④ **CSV File Button** to output the data values to a CSV file.

Page 34, 7. Saving Data (to a CSV file).

The following single-byte characters cannot be entered.

Android [,] [] [?] [>] [<] [/] [¥] [:] ["] [*] [\]
 iOS [,] [] [?] [>] [<] [/] [¥] [:] ["] [*] [\] [_]

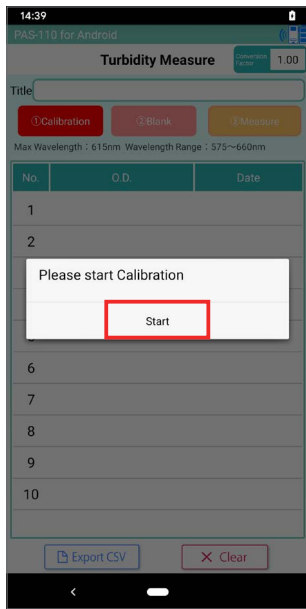

Illustration 5-2: Calibration

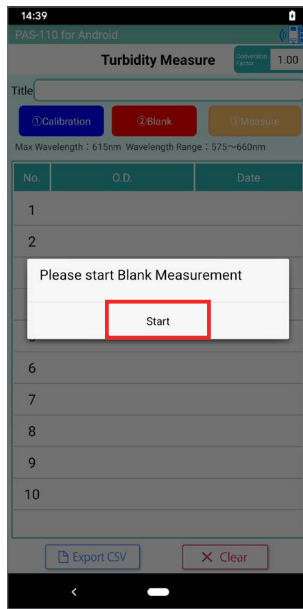

Illustration 5-3: Blank Measurement

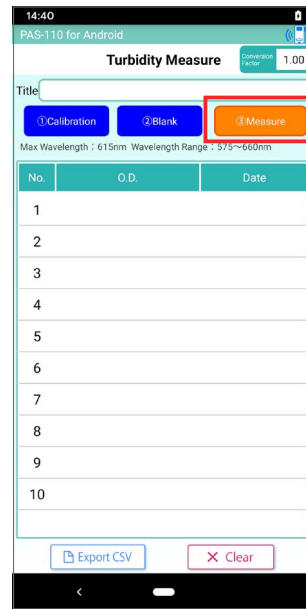

Illustration 5-4: Measurable State

If you want to measure different samples of cells or culture solution, tap the ② **Blank Measurement Button** and start from blank measurement again.

To clear the measurement results, tap the ⑦ **Clear Button**.

TAKING MEASUREMENTS

5-2. Conversion Factor

The Conversion Factor of O.D. to be displayed can be set in the ⑥ Conversion Factor Input Section.
(Illustration 5-5)

For example, by acquiring the correlation with another device and using the conversion value as a factor, it can be converted to the O.D. of another device.

This factor is independent of the Absorbance Multiplier <P37 8.Maintenance Screen>.

The O.D. is calculated based on the following equation.

$$\text{O.D.} = \text{Measured Value} \times \text{Conversion Factor}$$

The Conversion Factor is not common to all the devices, because the measurement value differs depending on the device.

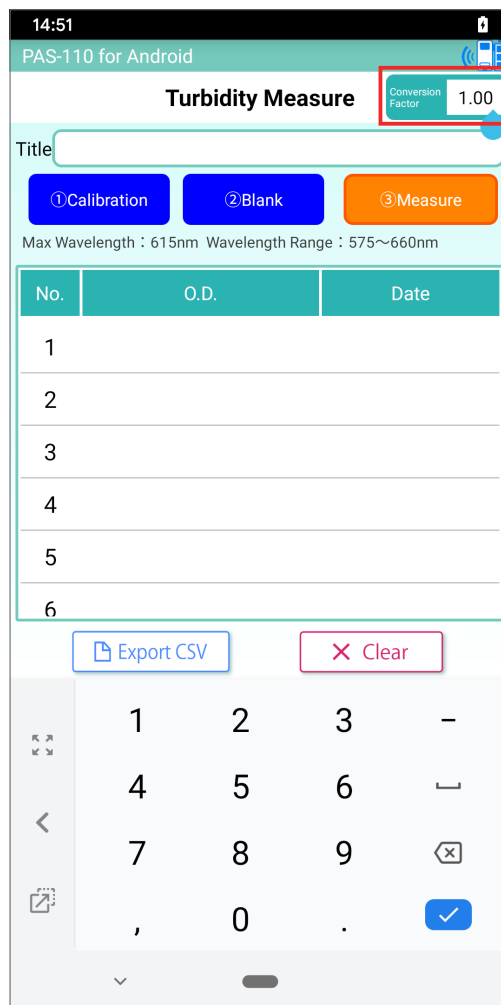

Illustration 5-5 : Conversion Factor Input Screen

If you change the Conversion Factor during measurement, the measurement result before the change will also reflect the changed Conversion Factor.

TAKING MEASUREMENTS

6. Displaying Previous Measurements

Tap the **Measurement History Button** on the top screen to move to the Measurement History Screen (Illustration 6-1).

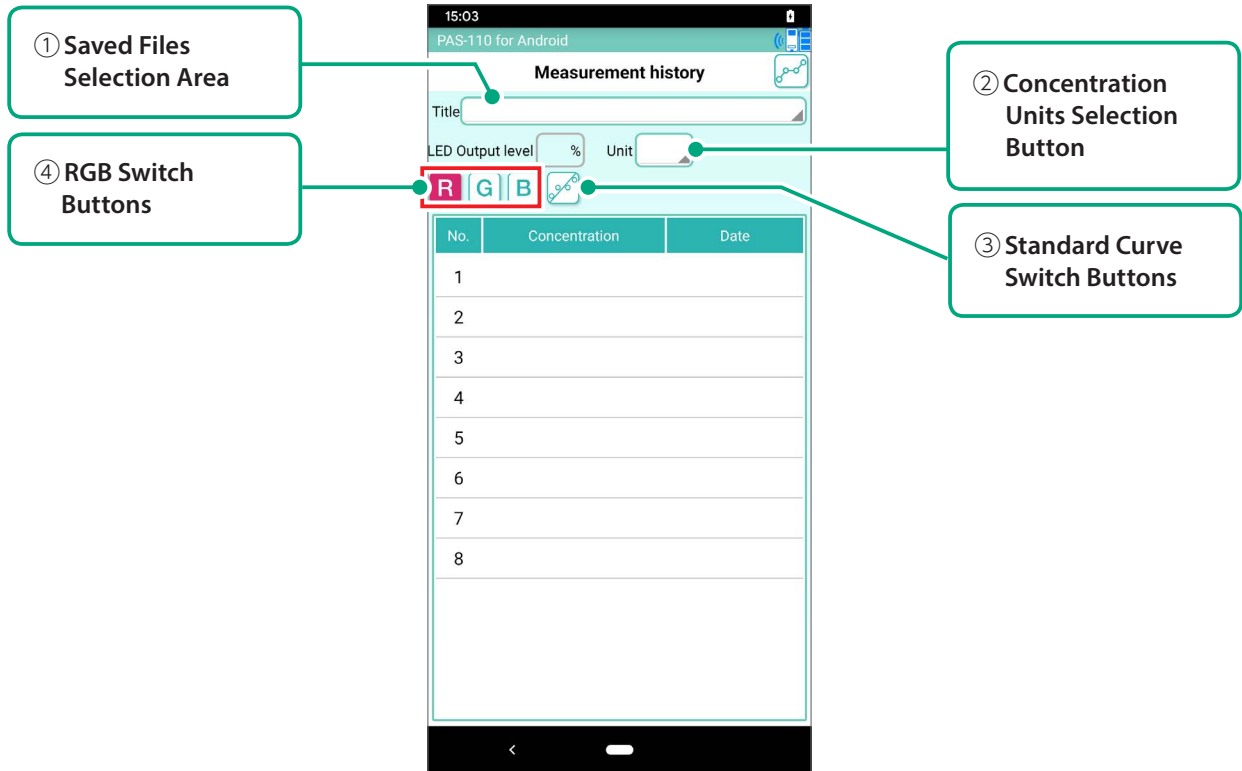

Illustration 6-1: Measurement History Screen

(1) Previously saved measurement data can be checked by tapping the **1 Saved Files Selection Area** and selecting the saved data.

At the case of concentration measurement, illustration 6-2 is displayed.
At the case of turbidity measurement, illustration 6-3 is displayed.

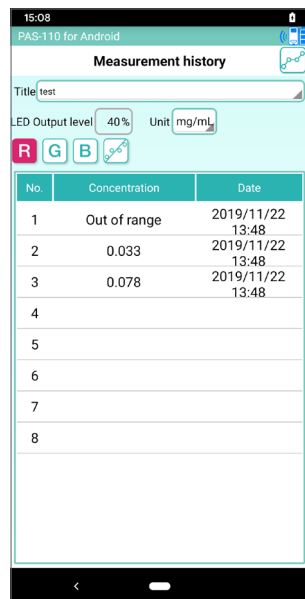

Illustration 6-2: Measurement History Screen of concentration measurement

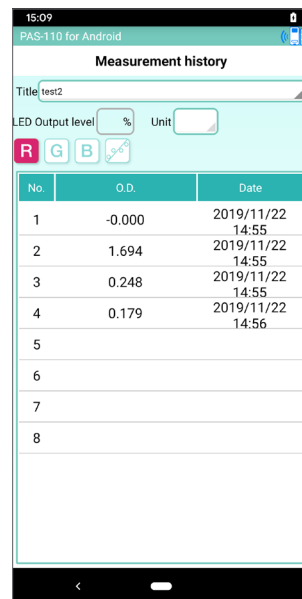

Illustration 6-3: Measurement History Screen of turbidity measurement

*At the case of turbidity measurement, it is not possible to select concentration units and wavelengths.

TAKING MEASUREMENTS

- (2) Units for the measurement value can be selected from among three options (concentration, intensity <RGB>, or absorbance <ABS> by tapping the ② **Concentration Unit Selection Button** shown in Illustration 6-4.

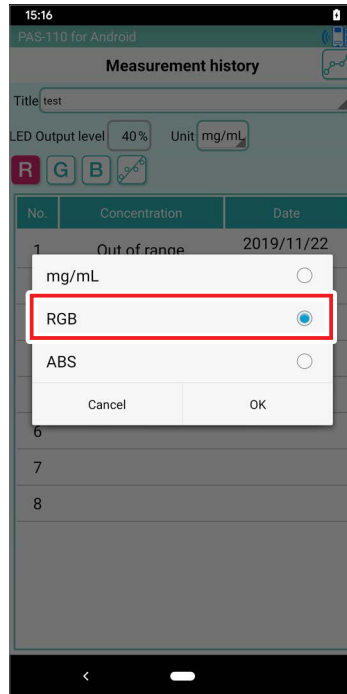

Illustration 6-4: Concentration Units Selection

- (3) Display switches to the unknown sample measurement value based on the least squares line when you tap the ③ **Standard Curve Switch Buttons**.
- (4) Display can be switched between measurement results for each of the RGB wavelength modes (Illustration 6-5) using the ④ **RGB Switch Buttons**.

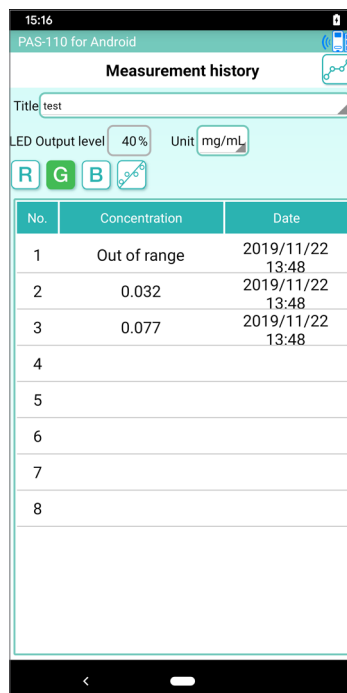

Illustration 6-5: Display of Measurement Data



TAKING MEASUREMENTS

7. Saving Data (to a CSV file)

Saved measurement data is accumulated in your Smartphone or tablet PC in CSV format. Here we explain how to output CSV files to a computer.

<For Android Devices>

- ① Connect your Smartphone or tablet PC to your computer with the USB cable.
- ② Extract the data as outlined below.
Android → data → com.ushio.pas110ui → files

<For iOS Devices (on iPhone or iPad)>

- ① Connect the tablet and computer.
- ② Open iTunes.
- ③ Select the connected tablet.
- ④ Select "App" below Settings.
- ⑤ Select "PAS-110" below File Sharing.
- ⑥ Select the file you saved with App.
- ⑦ Click "Add File..."
- ⑧ Select a folder to save the file.

Download iTunes from the link below.
<http://www.apple.com/jp/itunes/download/>

NOTE : On iOS, you can delete saved data only from iTunes.

- The CSV file format is as shown below.
- Concentration measurement result

Measurement Data

Measurement Result	test_190617	Timer function: FALSE	Absorbance multiplier: 2												
Selected-R	Color	No	Concentration (curve fitting by least square method)	Concentration (straight line connecting two points)	Unit	Value	Absorbance	LED Output Level	Sensor Accumulation Time	Temperature	DateTime				
R	1	0.019	0.02	mg/mL	20089	0.008	20	50	1449	2019/6/17 13:21					
R	2	0.043	0.041	mg/mL	19053	0.153	20	50	1448	2019/6/17 13:22					
R	3	0.082	0.081	mg/mL	16284	0.29	20	50	1452	2019/6/17 13:22					
R	4	0.035	0.034	mg/mL	19627	0.128	20	50	1452	2019/6/17 13:22					
R	5	0.138	0.138	mg/mL	12978	0.487	20	50	1451	2019/6/17 13:23					
G	1	0.010	0.02	mg/mL	31097	0.05	20	50	1449	2019/6/17 13:21					
G	2	0.041	0.041	mg/mL	28488	0.126	20	50	1448	2019/6/17 13:22					
G	3	0.079	0.08	mg/mL	24745	0.249	20	50	1452	2019/6/17 13:22					
G	4	0.033	0.034	mg/mL	29346	0.101	20	50	1452	2019/6/17 13:22					
G	5	0.135	0.135	mg/mL	20058	0.431	20	50	1451	2019/6/17 13:23					
B	1	0.011	0.019	mg/mL	30317	0.008	20	50	1449	2019/6/17 13:21					
B	2	0.056	0.048	mg/mL	29154	0.042	20	50	1448	2019/6/17 13:22					
B	3	0.082	0.083	mg/mL	20510	0.062	20	50	1452	2019/6/17 13:22					
B	4	0.025	0.026	mg/mL	29949	0.019	20	50	1452	2019/6/17 13:22					
B	5	0.137	0.138	mg/mL	27196	0.103	20	50	1451	2019/6/17 13:23					
Wavelength	Conc. ^{*1}		Conc. ^{*2}		Unit	Value	Abs.	LED Output Level	Sensor Accumulation Time	Temp.	Measurement Date				
StandardCurve															
Color	No	Concentration	Unit	Value1 Validity ^{*3}	Value1	Value2 Validity	Value2	Value3 Validity	Value3	Absorbance	LED Output Level	Sensor Accumulation Time	Temperature	DateTime	
R	0	0	mg/mL	TRUE	22737	TRUE	22738	TRUE	22717	0	20	50	1449	2019/6/17 13:21	
R	1	0.02	mg/mL	TRUE	21015	TRUE	21003	TRUE	21001	0.069	20	50	1449	2019/6/17 13:21	
R	2	0.04	mg/mL	TRUE	19175	TRUE	19175	TRUE	19197	0.147	20	50	1449	2019/6/17 13:21	
R	3	0.08	mg/mL	TRUE	16365	TRUE	16357	TRUE	16354	0.296	20	50	1449	2019/6/17 13:21	
R	4	0.16	mg/mL	TRUE	11941	TRUE	11912	TRUE	11918	0.56	20	50	1448	2019/6/17 13:21	
G	0	0	mg/mL	TRUE	32953	TRUE	32951	TRUE	32947	0	20	50	1449	2019/6/17 13:21	
G	1	0.02	mg/mL	TRUE	31100	TRUE	31096	TRUE	31099	0.05	20	50	1449	2019/6/17 13:21	
G	2	0.04	mg/mL	TRUE	28662	TRUE	28675	TRUE	28693	0.121	20	50	1449	2019/6/17 13:21	
G	3	0.08	mg/mL	TRUE	24817	TRUE	24806	TRUE	24805	0.246	20	50	1449	2019/6/17 13:21	
G	4	0.16	mg/mL	TRUE	18261	TRUE	18255	TRUE	18256	0.513	20	50	1449	2019/6/17 13:21	
B	0	0	mg/mL	TRUE	30617	TRUE	30621	TRUE	30607	0	20	50	1449	2019/6/17 13:21	
B	1	0.02	mg/mL	TRUE	30301	TRUE	30300	TRUE	30306	0.009	20	50	1449	2019/6/17 13:21	
B	2	0.04	mg/mL	TRUE	29285	TRUE	29300	TRUE	29317	0.038	20	50	1449	2019/6/17 13:21	
B	3	0.08	mg/mL	TRUE	26599	TRUE	26582	TRUE	26592	0.06	20	50	1449	2019/6/17 13:21	
B	4	0.16	mg/mL	TRUE	26709	TRUE	26699	TRUE	26700	0.119	20	50	1449	2019/6/17 13:21	

Calibration Curve Data

*1 Based on calibration curve of fitting line
*2 Based on calibration curve of obtained by complementing two points

*3 TRUE appears if a measurement has been taken, FALSE if no measurement taken. TRUE is displayed in all columns here because three measurement were taken.

- Turbidity measurement result

Measurement Result	test_od	Conversion Factor	1	Calibration time	2019/6/17 13:14
SelectedR					
Color	No	O.D.	Sensor Accumulation Time	Temperature	Date Time
R Blank	0	0	50	1437	2019/6/17 13:14
R	1	0.001	50	1441	2019/6/17 13:15
R	2	0.034	50	1441	2019/6/17 13:15
R	3	0.074	50	1440	2019/6/17 13:15
R	4	0.14	50	1442	2019/6/17 13:15
R	5	0.281	50	1443	2019/6/17 13:15

Optical Density Sensor Accumulation Time Temp. Measurement Date



8. Info Screen

Tap the Info Button on the top screen to move to the Info Screen (Illustration 8-1).

The Info Screen displays information on both the hardware photo absorbance sensor and the mobile app.

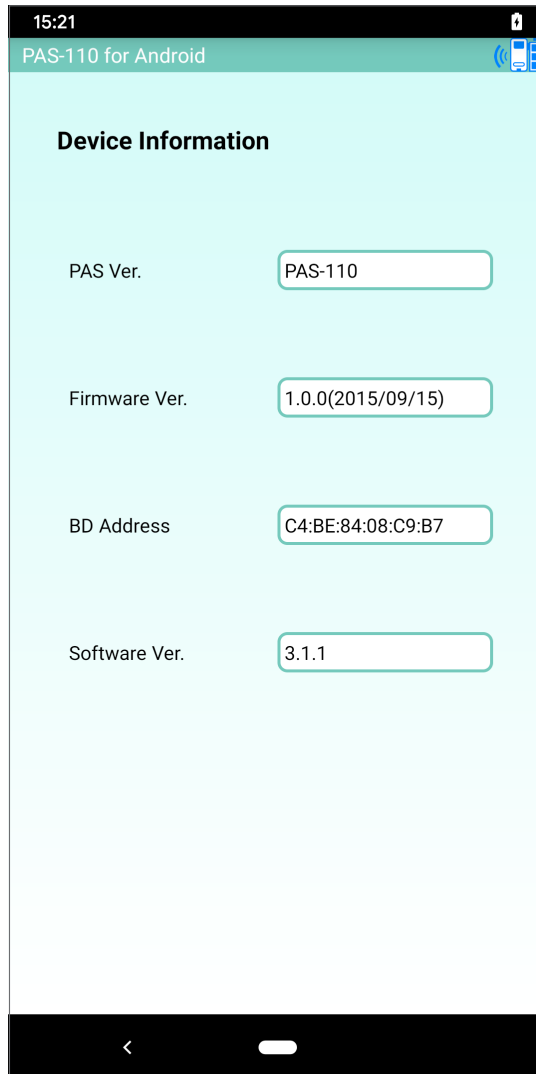

Illustration 8-1: Info Screen

9. Maintenance Screen

Tap the **Maintenance Button** on the top screen to move to the Maintenance Screen (Illustration 9-1). The Maintenance Screen displays the ① **Diagnostics Button** and ② **Function Settings Buttons**.

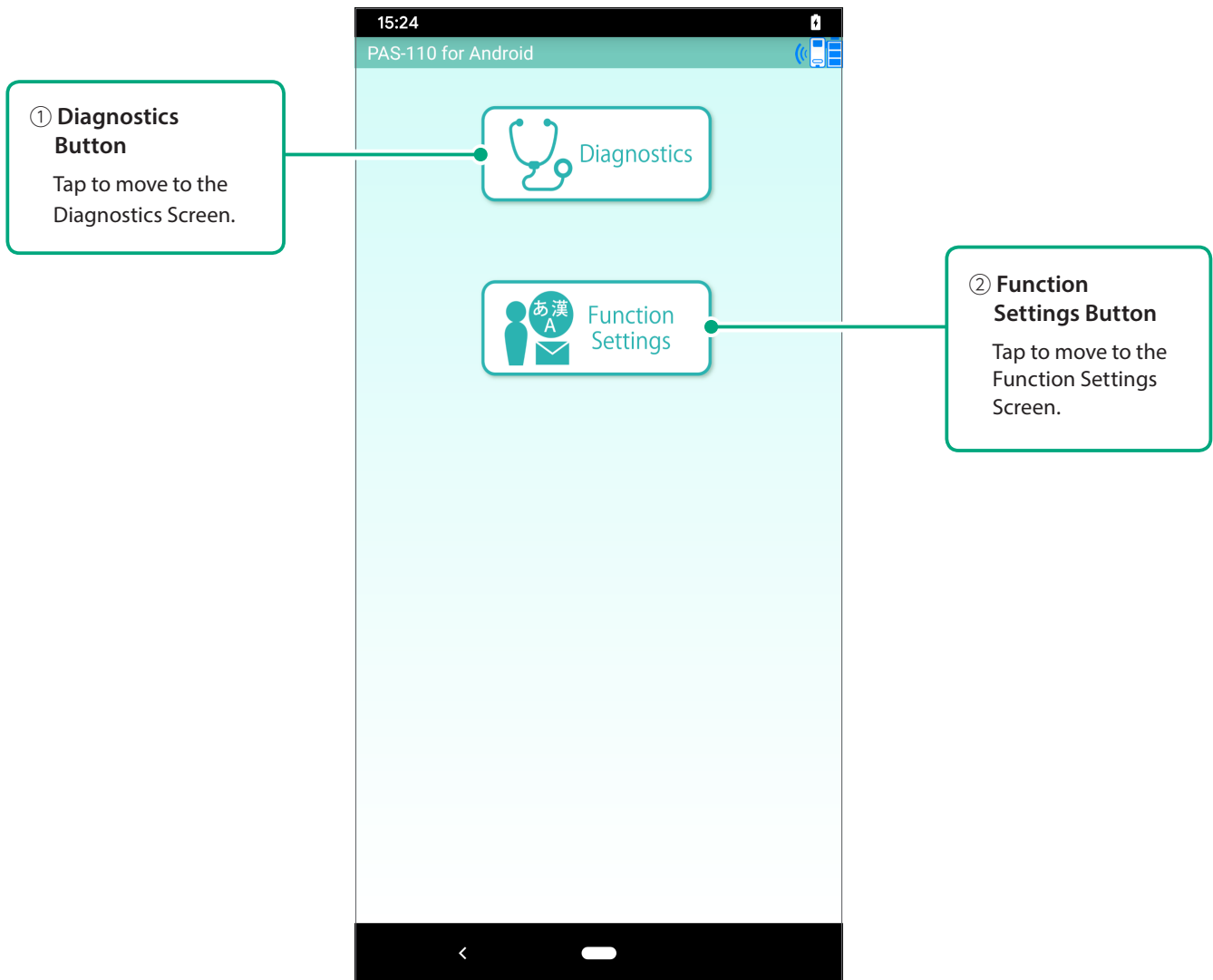

Illustration 9-1: Maintenance Screen

The ① **Diagnostics Button** is used by manufacturer to check device operation. Please do not use it.

Tap the ② **Function Settings Button** to move to the Function Settings screen. From this screen, you can make the following settings(Illustration 9-2).

Language: Switch between English, Japanese and Chinese.

Sensor Accumulation Time: Change the time for light volume accumulation. The initial setting is 50 ms. If you change this setting, set an appropriate LED output level as explained on [<pages 14-15>](#).

Timer Function: Set the Timed Measurement function [<pages 27-28>](#). Setting timed measurement ON enables the **Timed Measurement Button**.

Absorbance Multiplier: Set the multiplier for absorbance display. For example, correlation with a previously used instrument can be taken, then the calculated Conversion Factor can be set to allow conversion from another device's absorbance values.

This value is independent of the turbidity measurement Conversion Factor [<page 29>](#).

*Since absorbance values vary according to device, it is not possible to apply the same Conversion Factor to all devices.

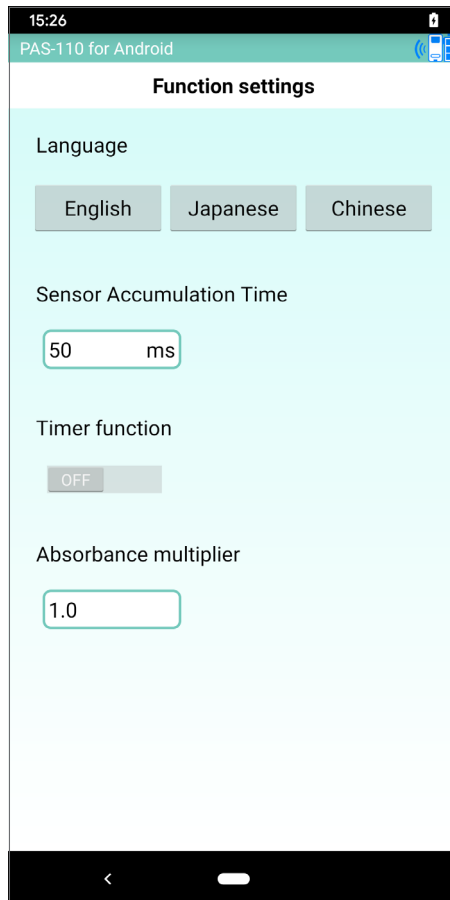

Illustration 9-2:
Function Settings Screen



10. Help Screen

Tap the **Help Button** on the top screen to move to the Help Screen (Illustration 10).

This screen provides a weblink to the user’s manual, troubleshooting guide, and other relevant documentation. Contact the Support Desk if you have any further questions or concerns.

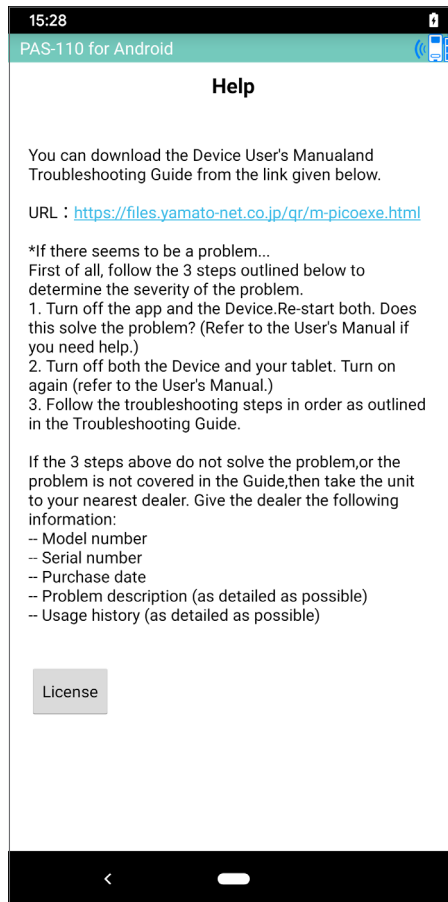

Illustration 10: Help Screen

MAINTENANCE



Do not wipe the device with organic solvents.
 Make sure the battery case cover is completely closed before cleaning.

Maintenance

• Device Exterior

Clean the device exterior with a clean, soft cloth wetted with a weak neutral detergent solution. Lightly wipe clean, then wipe again with a clean, dry cloth to remove all excess moisture.

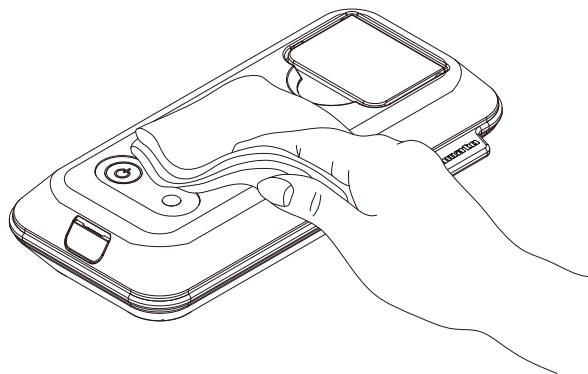

• Measurement Chamber

Do not use a stiff cloth to wipe the optical unit inside the chamber. Doing so can easily damage this sensitive component.

Remove dust and other contaminants from the optical unit by carefully wiping with a clean, soft cloth or cotton swab.

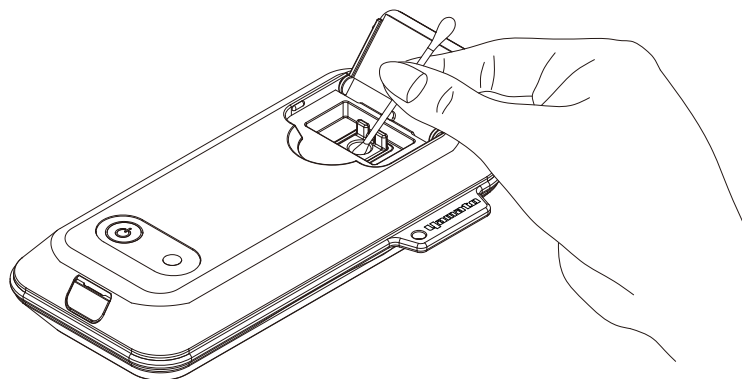

• Long-Term Storage

If the device will not be used for a long time, securely fasten the measurement chamber cover, and remove all batteries (refer to section on Battery Insertion). Close and lock the battery cover, and store in a secure location away from direct sunlight, dust, dirt, or high temperature or humidity.

TROUBLESHOOTING

[Problem Indicator 1] No power to unit or soon shuts off

Possible Cause	Solution
Batteries inserted incorrectly	Check batteries, re-insert correctly.
Batteries low or dead	Install fresh batteries (AAA x 3). Always change all 3 batteries together. A standard USB cable can also be used to supply power.
Electric short or malfunction	Possible damage due to shock of dropping or impact. Contact your dealer.

[Problem Indicator 2] No Bluetooth connection or connection lost

Possible Cause	Solution
Access permission to the location of the app and location service of the device are not ON. (Android only)	Please give the following permission to the app. <ul style="list-style-type: none"> • Location • Storage If these are OFF, you will be prompted for permission when the app is launched. Please turn on the location service of the device. Example (Google Pixel 3) : Settings → Security & location → Location
Auto-Off function killed connection (No connection for 2 minutes, auto shut-off)	Press power button on device to re-establish connection.
Device and receiver too far apart	Connection best at distance of less than 10 meters. Ambient conditions may impact transmission, so try to keep device and receiver as close as possible.
Interference from another device	Electrical interference may occur due to transmission by wireless LAN, microwave, or other Bluetooth devices in the vicinity. Move device and receiver away from such devices.
Too many possible receivers nearby	Turn off power to other nearby receivers.
Physical object blocking signal between device and receiver	Relocate device and receiver or remove object.
Device address not displayed on Connection Setting Screen	Please re-scan. Refer to Page 11, 2. Wireless Connection, in User's Manual.
App and device malfunction	Turn off both device and receiver, then turn on again. Data may be lost when you do this.
Batteries low	Even if the Status Light <P6> is not blinking, the battery voltage may not be sufficient. Install fresh batteries (AAA x 3). Always change all 3 batteries together. A standard USB cable can also be used to supply power.
Electrical short or malfunction inside device	Possible damage due to shock of dropping or impact. Contact your dealer.

[Problem Indicator 3] Can't take readings (or reading results variable)

Possible Cause	Solution
No Bluetooth connection	See "No Bluetooth Connection" section immediately above.
Bluetooth connection to other device	Re-connect to the photo absorbance sensor.
Standard curve not correctly received	Recheck data for errors. Refer to Page 13, 3. Graphing the Standard Curve, in User's Manual.
Error message: "The temperature is different from when the calibration curve was created"	This message displayed when there is an ambient temperature difference of about ±10°C between time when curve was drawn and time of measurement. Adjust ambient temperature and restart measurement.

TROUBLESHOOTING

[Problem Indicator 3] Can't take readings (or reading results variable)

Possible Cause	Solution
Screen freezes or display unstable	Turn off both device and receiver, then turn on again. Data may be lost when you do this.
Dirt or contaminant in measurement chamber	Clean chamber with a clean cotton swab or gauze. Do not use alcohol or organic solvent. Refer to Page 39, Maintenance, in User's Manual.
Too little sample in tube	Sample volume of 30µL or more required.
PCR Tube not inserted correctly	Check whether lid is properly closed and no foreign objects inside chamber. Reset tube in holder. Refer to Page 8 in User's Manual.
PCR Tube dimensions do not fit holder	Switch to supported tube size.
Device tilted	Place device on a stable, level surface (less than a 10° tilt from horizontal).
Sample concentration too strong	Adjust output strength of LEDs. (Make sure you have used correct volume and type of sample, and diluted correctly.) *
Sample concentration too weak	Make sure you have used correct volume and type of sample, and diluted correctly. *
Device cannot operate in current environment	Check operating parameters of device and use only in environments within the specified parameters.
Sample cannot be measured in current environment	Check specs of sample and only attempt measurement in environments within the specified parameters.
Deterioration of LED or sensor	Contact your dealer with details of how the device has been used.

Other Problem Indicators

Possible Cause	Solution
Device makes noise when tipped	Internal component may be damaged. Contact your dealer with details of how the device has been used.
Device was used or stored in environment outside specified parameters	
Liquid spilled on measurement unit	

*Fingerprints or moisture on the side of the PCR tube or bubbles in the tip of the PCR tube or sample can prevent correct measurement.

Warranty Policy

Yamato Scientific Co., Ltd. warrants this device to be free from physical defects in material and workmanship for a period of 1 year from the date of the original retail purchase. If the device fails during this period, the company will replace or repair the device free of charge.

However, this warranty is void under the following circumstances:

<ul style="list-style-type: none"> • failure due to device usage in violation of the environmental and handling specifications and procedures outlined in the guidelines found in the User’s Manual, catalog, and other relevant documentation
<ul style="list-style-type: none"> • failure due to device tampering or disassembly
<ul style="list-style-type: none"> • failure due to improper device storage
<ul style="list-style-type: none"> • failure due to accidental dropping or hard impact, or subjecting the device to undue pressure
<ul style="list-style-type: none"> • failure due to improper battery use or battery leakage
<ul style="list-style-type: none"> • failure due to device usage in a country not authorizing it

If Something Seems Wrong...

If you suspect a problem with the device, first follow these 3 simple steps:

- ① Turn off power to the device and turn off the app, then turn both back on.
- ② Turn off power to both the device and the tablet, then turn both back on.
- ③ Refer to the Troubleshooting Guide above, locate your problem, and see if the suggested solution solves the problem.

If the problem persists after this, or the problem indicator is not listed in the Troubleshooting Guide, contact your local dealer for help.

When contacting your dealer, be sure to provide the following information:

<ul style="list-style-type: none"> • Model Number
<ul style="list-style-type: none"> • Serial Number
<ul style="list-style-type: none"> • Date of Purchase
<ul style="list-style-type: none"> • Description of Problem (as detailed as possible)
<ul style="list-style-type: none"> • Usage History (as detailed as possible)

PiCOEXPLORER™ Support Desk

Yamato Scientific America, Inc.
 Email: technical@yamato-usa.com

SPECIFICATIONS

PAS-110-YU Hardware Unit

Device name		Photo absorbance sensor			
Brand		Yamato			
Model name		PiCOEXPLORER			
Dimensions		70 x 150 x 30 mm (excluding protrusions)			
Weight		about 200g (including batteries)			
Power		<ul style="list-style-type: none"> · 4.5V DC (3 AAA-type batteries) · 5V DC (micro-USB connector*1) 			
Operating voltage		Battery 3.6~4.5 Vdc			
Battery Life		about 5 hours ^{*2}			
Usage Environment	Temperature/Humidity	5-35 °C, 70% RH or less			
	Altitude	2000m or less			
	Installation Condition	indoor, pollution degree 2			
Measurement	Total Samples	1 sample			
	Time	1 second or more			
	Absorbance Range	0.02 or more (Gentian violet dilute solution)			
	Detection Limit	1 ng/mL (Bromophenol blue aqueous solution)			
Sensor Unit	Light Source	White LED			
	Detector		Maximum absorption wavelength	Wavelength range	
		Color Sensor	Red	615 nm	575-660 nm
		Green	530 nm	455-630 nm	
Blue	460 nm	400-540 nm			
Communication Interface		Bluetooth low energy (Bluetooth smart)			
Frequency of operation		2402-2480 MHz			
Type of modulation		GFSK			
Channel spacing		2 MHz			
Channel number		40			
Peak output power		Less than 0 dBm			
Antenna gain		2.41 dBi			
Antenna type		PCB Antenna			
Compatible Device		Android 5.0 or later, iOS 9.1 or later ^{*3}			
Supported PCR Tube		Cap type: Flat Volume: 0.2 mL			
Minimum Sample Volume		30 μL ^{*4}			

*1 Use the cable to connect to a computer or other appropriate power source to power the unit without batteries (the device automatically senses the power source; this connection cannot be used to transmit data.)

*2 This battery life is based on using new, fully-charged batteries. However, battery life cannot be guaranteed as different operating conditions can alter battery life drastically.

*3 As of June 2019.

*4 With a sample volume of 30μL, be sure to measure with the device tilted 10° or less from the horizontal.

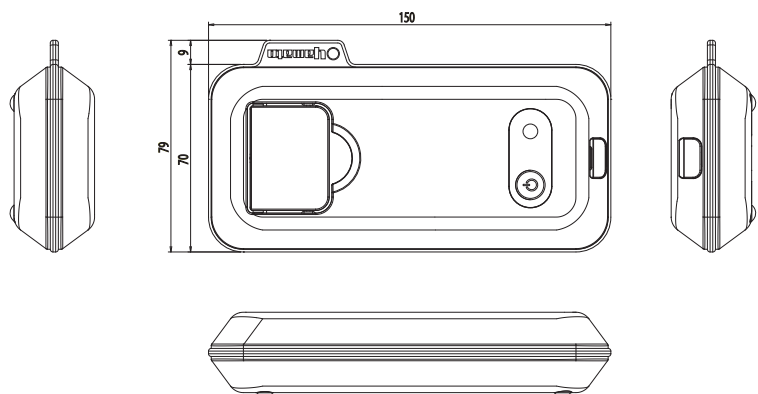

LAWS AND REGULATIONS / APPROVED STANDARDS

FCC NOTICE

This device complies with part 15 of the FCC Rules.

Operation is subject to the following two conditions:

- (1) This device may not cause harmful interference, and
- (2) this device must accept any interference received, including interference that may cause undesired operation.

Changes or modifications not expressly approved by the party responsible for compliance could void the user's authority to operate the equipment.

Note: This equipment has been tested and found to comply with the limits for a Class B digital device, pursuant to part 15 of the FCC Rules.

These limits are designed to provide reasonable protection against harmful interference in a residential installation.

This equipment generates, uses and can radiate radio frequency energy and, if not installed and used in accordance with the instructions, may cause harmful interference to radio communications. However, there is no guarantee that interference will not occur in a particular installation.

If this equipment does cause harmful interference to radio or television reception, which can be determined by turning the equipment off and on, the user is encouraged to try to correct the interference by one or more of the following measures:

- Reorient or relocate the receiving antenna.
- Increase the separation between the equipment and receiver.
- Connect the equipment into an outlet on a circuit different from that to which the receiver is connected.
- Consult the dealer or an experienced radio/TV technician for help.

IC NOTICE

This Class A digital apparatus complies with Canadian ICES-003.

Cet appareil numérique de la classe A est conforme à la norme NMB-003 du Canada.

This device complies with Industry Canada licence-exempt RSS standard(s). Operation is subject to the following two conditions: (1) this device may not cause interference, and (2) this device must accept any interference, including interference that may cause undesired operation of the device.

Le présent appareil est conforme aux CNR d'Industrie Canada applicables aux appareils radio exempts de licence.

L'exploitation est autorisée aux deux conditions suivantes : (1) l'appareil ne doit pas produire de brouillage, et

(2) l'utilisateur de l'appareil doit accepter tout brouillage radioélectrique subi, même si le brouillage est susceptible d'en compromettre le fonctionnement.

Yamato Scientific America, Inc.

925 Walsh Avenue, Santa Clara, CA 95050, USA

<http://www.yamato-usa.com> Toll Free: 1-800-292-6286