

# TwisTorr 305-IC

Pump models: X3513-64000, X3513-64001, X3513-64002, X3513-64003, X3513-64004, X3513-64005, X3513-64006, X3513-64007, X3513-64016, X3513-64017, X3513-64018, X3513-64019, X3513-64020, X3513-64021, X3513-64022, X3513-64023, X3513-64024, X3513-64025, X3513-64026, X3513-64027, X3513-64028, X3513-64029, X3513-64030, X3513-64031

**Manuale di istruzioni**

**Bedienungshandbuch**

**Notice de mode d'emploi**

**Manual de instrucciones**

**用户手册**

**ユーザーマニュアル**

**User Manual**

87-901-058-01

12/2019



**Agilent Technologies**

## Notices

© Agilent Technologies, Inc. 2019

No part of this manual may be reproduced in any form or by any means (including electronic storage and retrieval or translation into a foreign language) without prior agreement and written consent from Agilent Technologies, Inc. as governed by United States and international copyright laws.

## Manual Part Number

Publication Number: 87-901-058-01

## Edition

Edition 12/2019

Printed in ITALY

Agilent Technologies Italia S.p.A.

Vacuum Products Division

Via F.lli Varian, 54

10040 Leini (TO)

ITALY

## Warranty

**The material contained in this document is provided “as is,” and is subject to being changed, without notice, in future editions. Further, to the maximum extent permitted by applicable law, Agilent disclaims all warranties, either express or implied, with regard to this manual and any information contained herein, including but not limited to the implied warranties of merchantability and fitness for a particular purpose. Agilent shall not be liable for errors or for incidental or consequential damages in connection with the furnishing, use, or performance of this document or of any information contained herein. Should Agilent and the user have a separate written agreement with warranty terms covering the material in this document that conflict with these terms, the warranty terms in the separate agreement shall control.**

## Technology Licenses

The hardware and/or software described in this document are furnished under a license and may be used or copied only in accordance with the terms of such license.

## Restricted Rights Legend

If software is for use in the performance of a U.S. Government prime contract or subcontract, Software is delivered and licensed as “Commercial computer software” as defined in DFAR 252.227-7014 (June 1995), or as a “commercial item” as defined in FAR 2.101(a) or as “Restricted computer software” as defined in FAR 52.227-19 (June 1987) or any equivalent agency regulation or

contract clause. Use, duplication or disclosure of Software is subject to Agilent Technologies’ standard commercial license terms, and non-DOD Departments and Agencies of the U.S. Government will receive no greater than Restricted Rights as defined in FAR 52.227-19(c)(1-2) (June 1987). U.S. Government users will receive no greater than Limited Rights as defined in FAR 52.227-14 (June 1987) or DFAR 252.227-7015 (b)(2) (November 1995), as applicable in any technical data.

## Trademarks

Windows and MS Windows are U.S. registered trademarks of Microsoft Corporation.

## Safety Notices

### CAUTION

A **CAUTION** notice denotes a hazard. It calls attention to an operating procedure, practice, or the like that, if not correctly performed or adhered to, could result in damage to the product or loss of important data. Do not proceed beyond a **CAUTION** notice until the indicated conditions are fully understood and met.

### WARNING

A **WARNING** notice denotes a hazard. It calls attention to an operating procedure, practice, or the like that, if not correctly performed or adhered to, could result in personal injury or death. Do not proceed beyond a **WARNING** notice until the indicated conditions are fully understood and met.

## TwisTorr 305-IC



Page intentionally left blank

# Contents

<b>1 Istruzioni per l'uso</b>	<b>15</b>
Informazioni su questo manuale	17
Validità	17
Definizioni e terminologia	18
Definizione di Attenzione, Avvertenza e Nota	18
Simboli di Avvertenza	19
Sicurezza	21
Uso corretto	21
Uso improprio	22
Attrezzatura di protezione	23
Linee guida di sicurezza per pompe turbomolecolari	25
Transporto & Immagazzinamento	26
Descrizione del prodotto	27
Installazione	28
Preparazione per l'installazione	28
Apertura	30
Riparazione di TwisTorr 305-IC	32
Collegamento della flangia per alto vuoto	33
Installazione della flangia ISO-K	34
Installazione della flangia ConFlat	35
Collegamento della pompa del vuoto anteriore	36
Avvio e funzionamento di TwisTorr 305-IC	37
Arresto di TwisTorr 305-IC	40
Arresto di emergenza	40
Manutenzione	41
Vita del rotore	41

## Contents

Soft Start	42
Pulizia	42
Smaltimento	43
Servizio Post Vendita	44
<b>2</b>	<b>45</b>
<b>Gebrauchsanleitung</b>	<b>45</b>
Über dieses Handbuch	47
Gültigkeit	47
Begriffsbestimmungen und Terminologie	48
Definition von Vorsicht, Warnung und Hinweis	48
Warnsymbole	49
Sicherheit	51
Sachgemäße Verwendung	51
Unsachgemäße Verwendung	52
Schutzausrüstung	53
Sicherheitsrichtlinie für Turbomolekularpumpen	55
Transport und Lagerung	56
Produktbeschreibung	57
Installation	58
Vorbereitung zum Einbau	58
Einrichten	60
Montage von TwisTorr 305-IC	62
Anschluss des Hochvakuumflansches	63
Installation des ISO-K-Flansches	64
Installation des ConFlat-Flansches	65
Anschluss der Vorvakuumpumpe	66
Inbetriebnahme und Betrieb vom TwisTorr 305-IC	67
TwisTorr 305-IC stoppen	70
Notausschaltung	70
Wartung	71
Rotordauer	71

Sanftanlauf	72
Reinigung	72
Entsorgung	73
Service	74
<b>3 Mode d'emploi</b>	<b>75</b>
À propos de ce manuel	77
Validité	77
Définitions et terminologie	78
Symboles d'avertissement	79
Sécurité	81
Utilisation appropriée	81
Utilisation inappropriée	82
Équipement de protection	83
Directive de sécurité pour les pompes turbomoléculaires	85
Transport et entreposage	86
Description du produit	87
Installation	88
Préparation pour l'installation	88
Configuration	90
Montage du TwisTorr 305-IC	92
Raccordement de la bride à vide élevé	93
Installation de la bride ISO-K	94
Installation de la bride ConFlat	95
Raccordement de la bride à vide préliminaire	96
Démarrage et utilisation du TwisTorr 305-IC	97
Arrêt du TwisTorr 305-IC	100
Arrêt d'urgence	100
Entretien	101
Durée de vie du rotor	101
Démarrage progressif	102

## Contents

Nettoyage	102
Mise au rebut	103
Service	104
<b>4 Instrucciones de Uso</b>	<b>105</b>
Acerca del manual	107
Validez	107
Definiciones y terminología	108
Definición de Precaución, Advertencia y Nota	108
Símbolos de advertencia	109
Seguridad	111
Uso correcto	111
Uso incorrecto	112
Equipo de protección	113
Pautas de seguridad para bombas turbomoleculares	115
Transporte y almacenamiento	116
Descripción del producto	117
Instalación	118
Preparación para instalación	118
Puesta en marcha	120
Montaje de la TwisTorr 305-IC	122
Conexión de la brida de alto vaciado	123
Instalación de la brida ISO-K	124
Instalación de la brida ConFlat	125
Conexión de la bomba pre-vaciado	126
Puesta en marcha y funcionamiento de TwisTorr 305-IC	127
Parada de la TwisTorr 305-IC	130
Parada de emergencia	130
Mantenimiento	131
Vida del rotor	131
Arranque suave	132

Limpieza	132
Eliminación	133
Servicio	134
<b>5 使用说明</b>	<b>135</b>
关于这本手册	137
有效性	137
定义和术语	138
警告、警告和注释的定义	138
警告符号	139
安全	141
正确使用	141
使用不当	142
防护设备	143
涡轮分子泵安全指南	145
运输及存储	146
产品描述	147
安装	148
安装准备	148
设置	150
TwisTor 305-IC 的安装	152
高真空法兰的连接	153
ISO-K 法兰的安装	154
ConFlat 法兰的安装	155
前真空泵的连接	156
TwisTorr 305-IC 的启动和运行	157
停止 TwisTorr 305-IC	160
紧急停止	160
维护	161

## Contents

转子寿命	161
慢启动	162
清洗	162
处置方式	163
服务	164
<b>6 使用方法</b>	<b>165</b>
このマニュアルについて	167
<b>有効性</b>	167
定義と用語	168
警告・注意・注の定義	168
警告の記号	169
<b>安全性</b>	171
<b>適切な使用</b>	171
<b>不適切な使用</b>	172
保護用装備	173
ターボ分子ポンプ用安全ガイドライン	175
移送&保管	176
製品説明	177
取り付け	178
取り付けの準備	178
セットアップ	180
<b>TwisTorr 305-IC 実装</b>	182
高真空フランジの接続	183
ISO-K フランジの取り付け	184
ConFlat フランジの取り付け	185
フォア真空ポンプの接続	186
TwisTorr 305-IC の起動開始と操作	187
TwisTorr 305-IC を停止する	190

緊急停止	190
メンテナンス	191
ローターの寿命	191
ソフトスタート	192
クリーニング	192
廃棄	193
サービス	194
<b>7 Instructions for Use</b>	<b>195</b>
About this manual	197
Validity	197
Definitions and terminology	198
Definition of Caution, Warning and Note	198
Warning Symbols	199
Safety	201
Proper Use	201
Improper Use	202
Protective equipment	203
Safety Guideline for Turbomolecular Pumps	205
Transport & Storage	206
Product description	207
Installation	208
Preparation for Installation	208
Set-up	210
TwisTorr 305-IC Mounting	212
Connection of the High Vacuum Flange	213
Installation of ISO-K Flange	214
Installation of ConFlat Flange	215
Connection of the Fore-Vacuum Pump	216
Startup and Operation of the TwisTorr 305-IC	217

## Contents

Stopping the TwisTorr 305-IC	220
Emergency stop	220
Maintenance	221
Rotor life	221
Soft Start	222
Cleaning	222
Disposal	223
Service	224
<b>8 Technical Information</b>	<b>225</b>
Description of the TwisTorr 305-IC	227
Technical Specification	233
TwisTorr 305-IC Outline	236
Pump Operations	247
Inlet screen installation	247
Air Cooling Kit Installation (only for air cooled pumps)	250
Assembling procedure Air Cooling Kit X3500-68010	251
Water Cooling Kit Connection (only for water cooling pumps)	255
Vent Accessories	258
Pump Used with Corrosive and Oxidizing Gases	261
Purge Valve Installation	263
Pump Used in Presence of Magnetic Fields	264
Vibration Isolator Installation	264
Controller Operations	265
Interconnections	265
1 - Vent	266
2 - External Fan	266
3 - IN/OUT and Power Supply	266
Signal Description	268

How to Connect the Open Collector Inputs of the Controller	272
How to Connect the Controller Outputs	273
RS485/RS232 communication description	274
Windows Protocol	276
Window Description	281
NFC Function	287
Screenshot APP	289
Connection through USB plug	290
Error messages	291
Warning messages	293
Accessories and Spare Parts	295

## Contents

Page intentionally left blank



## 1 Istruzioni per l'uso

Informazioni su questo	17
Validità	17
Definizioni e terminologia	18
Definizione di Attenzione, Avvertenza e Nota	18
Simboli di Avvertenza	19
Sicurezza	21
Uso corretto	21
Uso improprio	22
Attrezzatura di protezione	23
Linee guida di sicurezza per pompe turbomolecolari	25
Transporto & Immagazzinamento	26
Descrizione del prodotto	27
Installazione	28
Preparazione per l'installazione	28
Apertura	30
Riparazione di TwisTorr 305-IC	32
Collegamento della flangia per alto vuoto	33
Installazione della flangia ISO-K	34
Installazione della flangia ConFlat	35
Collegamento della pompa del vuoto anteriore	36
Avvio e funzionamento di TwisTorr 305-IC	37
Arresto di TwisTorr 305-IC	40
Arresto di emergenza	40
Manutenzione	41
Vita del rotore	41
Soft Start	42
Pulizia	42
Smaltimento	43
Servizio Post Vendita	44

## **1 TwisTorr 305-IC Manuale di istruzioni**

## Informazioni su questo manuale

### Validità

Questo manuale elenca le istruzioni per gli utenti di TwisTorr 305-IC, con particolare riferimento alle nozioni relative a sicurezza, funzionamento e manutenzione di primo livello, limitatamente alle operazioni di manutenzione di cui l'utente è responsabile.

Le operazioni di manutenzione, illustrate nelle sezioni specifiche, con disposizioni specifiche relative al livello più elevato di manutenzione (personale appositamente addestrato per le operazioni di manutenzione) non devono essere eseguite dall'utente.

Per una corretta installazione e avvio/arresto, consultare il capitolo "Installazione". Per un uso tecnico più dettagliato, consultare il capitolo "Operazioni".

Per ulteriori dettagli sull'utilizzo tecnico, consultare il capitolo "Operazioni".

#### NOTA

1. Questo manuale contiene informazioni utili affinché tutto il personale che utilizza TwisTorr 305-IC possa utilizzarlo in sicurezza e garantire la perfetta efficienza, per tutta la sua durata.
2. Conservare questo manuale, insieme a tutte le pubblicazioni ad esso correlate, in un luogo accessibile, conosciuto da tutti gli operatori/personale di manutenzione.

## Definizioni e terminologia

### Definizione di Attenzione, Avvertenza e Nota

Alcuni riferimenti importanti di questo manuale sono evidenziati e incorniciati in colori contrastanti.

---

#### AVVERTENZA!



I messaggi di avvertenza attirano l'attenzione dell'operatore su una procedura o una pratica specifica che, se non eseguita in modo corretto, potrebbe provocare gravi lesioni personali.

---

#### ATTENZIONE!

I messaggi di attenzione sono visualizzati prima di procedure che, se non osservate, potrebbero causare danni all'apparecchiatura.

---

#### NOTA

Le note contengono informazioni importanti e forniscono maggiori dettagli su passaggi specifici.

---

## Simboli di Avvertenza

Di seguito si riporta un elenco di simboli che vengono visualizzati insieme agli avvisi TwisTorr 305-IC. Viene mostrato anche il pericolo che descrivono.

Un simbolo triangolare indica un'avvertenza. I significati dei simboli che possono apparire accanto alle avvertenze nella documentazione o sullo strumento stesso sono i seguenti:



Corrente continua



Non toccare



Dichiarazione Europea di  
Conformità



Pericolo generico



Sito di produzione



Spegni



Accendi



Messa a terra protettiva



## 1 Istruzioni per l'uso

### Simboli di Avvertenza

Il seguente simbolo può essere usato sulle etichette di avvertenza attaccate allo strumento. Quando viene visualizzato questo simbolo, consultare il relativo manuale operativo o di servizio per la procedura corretta a cui fa riferimento tale etichetta di avvertenza.



I seguenti simboli appaiono sullo strumento per vostra informazione.

	Accensione principale
	Se rosso, significa malfunzionamento
	Se giallo, significa avvertenza
	Porta USB
	Messa a terra protettiva
	Non toccare
J1	Connettore principale
NFC	Near Field Communication (antenna dello smartphone)
	Certificazione CE
	Certificazione CSA
RoHS	Limitazione della Certificazione delle Sostanze Pericolose
	Certificazione RoHS China
	Rifiuti di Apparecchiature Elettriche ed Elettroniche

## Sicurezza

Questa sezione contiene le informazioni, prescritte dalla Direttiva Macchine 2006/42/CE, che sono essenziali per la conformità e il rispetto delle norme di sicurezza sia in generale che in relazione all'uso specifico della macchina.

La mancata osservanza di queste istruzioni e delle altre istruzioni contenute nel presente manuale può rendere inefficaci le condizioni di sicurezza previste in fase di progettazione e causare incidenti a chi utilizza la macchina.

Agilent Technologies declina ogni responsabilità per danni alla macchina o per la sicurezza fisica dell'operatore o di terzi derivanti dal mancato rispetto delle norme di sicurezza indicate nella documentazione tecnica.

## Uso corretto

Questo manuale contiene importanti avvertenze e istruzioni di sicurezza da osservare affinché l'unità funzioni in sicurezza.

Il prodotto descritto in questo manuale è destinato esclusivamente all'ambito specificato nelle istruzioni. Il manuale fornisce inoltre indicazioni relative ai requisiti essenziali per l'applicazione e il funzionamento del prodotto, nonché le misure di sicurezza che possono essere adottate per garantire un funzionamento regolare. Agilent Technologies non fornisce alcuna garanzia né si assume alcuna responsabilità per applicazioni diverse da quelle descritte nel presente manuale o in cui i requisiti essenziali e le misure di sicurezza non siano rispettati. Il prodotto deve essere utilizzato solo da personale qualificato in grado di adottare le misure di sicurezza necessarie in condizioni che non causano danni o lesioni. Gli accessori e le attrezzature utilizzati con il prodotto devono essere forniti o approvati da Agilent Technologies.

Qualsiasi operazione di regolazione o manutenzione deve essere eseguita da un tecnico professionista informato dei rischi.

Le riparazioni sul prodotto devono essere eseguite esclusivamente da personale autorizzato Agilent.

## Uso improprio

Agilent Technologies declina ogni responsabilità derivante dall'uso improprio di TwisTorr 305-IC.

L'uso improprio comporterà la perdita di tutti i reclami per responsabilità e garanzie. L'uso improprio è definito come:

- installazione della pompa con materiale di montaggio non specificato
- pompaggio di gas corrosivi e ossidanti senza flusso di spurgo adeguato (vedere la sezione "Pompa utilizzata con gas corrosivi e ossidanti")
- pompaggio di gas esplosivi
- pompaggio di vapori di condensazione
- pompaggio di liquidi
- pompaggio di polvere
- funzionamento con flusso di gas elevato improprio
- funzionamento con pressioni inadeguate per il vuoto avanzato
- funzionamento con modalità gas selezionata diversa dal gas effettivamente utilizzato
- funzionamento con elevati livelli impropri di apporto termico isolato
- funzionamento in campi magnetici elevati impropri
- ventilazione con alte velocità di ventilazione inadeguate
- utilizzo della pompa del vuoto per generare pressione
- funzionamento del dispositivo in aree con radiazioni ionizzate
- funzionamento in aree potenzialmente esplosivo
- utilizzo del dispositivo in sistemi in cui stress e vibrazioni simili a impatti o forze periodiche influiscono sul dispositivo.

## Attrezzatura di protezione

L'attrezzatura di protezione degli operatori che stanno operando o eseguendo la manutenzione del sistema di pompaggio deve essere sempre adeguata al tipo di operazione da eseguire. Inoltre, deve soddisfare i requisiti di sicurezza della legislazione in vigore nel paese in cui viene utilizzata la macchina.

In generale, l'operatore deve indossare scarpe antinfortunistiche durante la manipolazione del 305-IC e durante l'installazione.



### **AVVERTENZA!**

#### **Pericolo per la salute a causa di sostanza pericolose durante la manutenzione o l'installazione**

A seconda della peculiarità del processo, le pompe per vuoto, i componenti o i fluidi di funzionamento possono essere contaminati da sostanze tossiche, reattive o radioattive.

→ Indossare attrezzatura di protezione adeguata durante la manutenzione e le riparazioni o in caso di reinstallazione.



### **AVVERTENZA!**

#### **Rischio di lesioni dovute alla caduta di oggetti**

Durante il trasporto manuale delle pompe per vuoto, sussiste il pericolo che i carichi scivolino e cadano.

→ Trasportare pompe per vuoto di piccole e medie dimensioni a due mani.

→ Qualsiasi attrezzatura più pesante di 20 kg deve essere trasportata utilizzando un dispositivo di sollevamento adatto.

→ Indossare scarpe antinfortunistiche con puntale in acciaio secondo la direttiva EN 347.

## 1 Istruzioni per l'uso

### Attrezzatura di protezione

---



#### **ATTENZIONE!** Rischio di lesioni a causa di spigoli vivi

I rischi del rotore e dello statore delle turbopompe hanno bordi molto affilati.

- ➔ Prima di riparare la pompa o prima di qualsiasi azione di montaggio/smontaggio della pompa del sistema, attendere per l'arresto completo della pompa.
  - ➔ Non operare direttamente all'interno della pompa.
  - ➔ Se necessario, indossare guanti protettivi secondo la EN 420.
-

## Linee guida di sicurezza per pompe turbomolecolari

Le pompe turbomolecolari descritte nel seguente manuale contengono una grande quantità di energia cinetica dovuta all'elevata velocità di rotazione in combinazione con la massa specifica dei loro rotori.

In caso di malfunzionamento di una parte meccanica della pompa, l'energia di rotazione può essere rilasciata a qualunque cosa sulla quale la pompa sia fissata.

---

**AVVERTENZA!**

**Per evitare danni alle apparecchiature e per prevenire lesioni al personale operativo, è necessario seguire scrupolosamente le istruzioni di installazione fornite nel presente manuale!**

---

## Transporto & Immagazzinamento

Al fine di garantire il massimo livello di prestazioni e affidabilità delle pompe turbomolecolari Agilent, è necessario seguire le seguenti linee guida per evitare la condensa:

- durante la spedizione, lo spostamento e lo stoccaggio delle pompe, non devono essere superate le seguenti specifiche ambientali:
  - intervallo di temperatura: -da 40 °C a 70 °C
  - intervallo di umidità relativa: da 0 a 90 % (senza condensa).
- la durata di conservazione di una pompa turbomolecolare è di 12 mesi dalla data di spedizione.
- le pompe turbomolecolari devono essere sempre avviate progressivamente quando vengono ricevute e utilizzate per la prima volta dal cliente.
- le pompe turbomolecolari devono essere sempre avviate gradualmente dopo un periodo di inattività della pompa di 60 giorni.

### **ATTENZIONE!**

Se per qualsiasi motivo viene superata la scadenza della conservazione, la pompa deve essere restituita alla fabbrica. Per informazioni, contattare il rappresentante Agilent Vacuum locale e il servizio di assistenza.

---

## Descrizione del prodotto

Questa attrezzatura è destinata all'uso professionale e deve essere utilizzata da professionisti.

TwisTorr 305-IC è una pompa turbomolecolare per applicazioni con vuoto elevato e altissimo che è in grado di pompare qualsiasi tipo di gas o composto di gas non corrosivo e ossidante.

L'azione di pompaggio si ottiene attraverso una turbina ad alta velocità (max. 60600 rpm) azionata da un motore elettrico ad alte prestazioni.

È privo di agenti contaminanti e, quindi, è adatto per applicazioni che richiedono un vuoto "pulito".

Informazioni dettagliate sono fornite nella sezione "Informazioni tecniche".

## Installazione

### Preparazione per l'installazione

TwisTorr 305-IC viene fornito in un imballo protettivo speciale; se si presentano segni di danni, che potrebbero essersi verificati durante il trasporto, contattare l'ufficio vendite locale.

Evitare impatti improvvisi sul 305-IC che potrebbero essere causati dalla sua caduta. Fare attenzione a conservare la confezione per riutilizzarla in caso di conservazione per un lungo periodo di tempo o in caso di spedizione.

Non gettare i materiali di imballaggio in modo non autorizzato. Il materiale è riciclabile al 100% ed è conforme alla Direttiva CEE 94/62 e successive modifiche.

#### ATTENZIONE!

Per evitare problemi di degassificazione, non usare le mani nude per maneggiare i componenti che saranno esposti al vuoto. Usare sempre guanti o altre protezioni appropriate.

---

#### NOTA

La normale esposizione all'ambiente non può danneggiare TwisTorr 305-IC. Tuttavia, si consiglia di tenerlo sigillato nella sua busta di plastica fino a quando non viene installato nel sistema, evitando così qualsiasi forma di inquinamento da polvere.

---

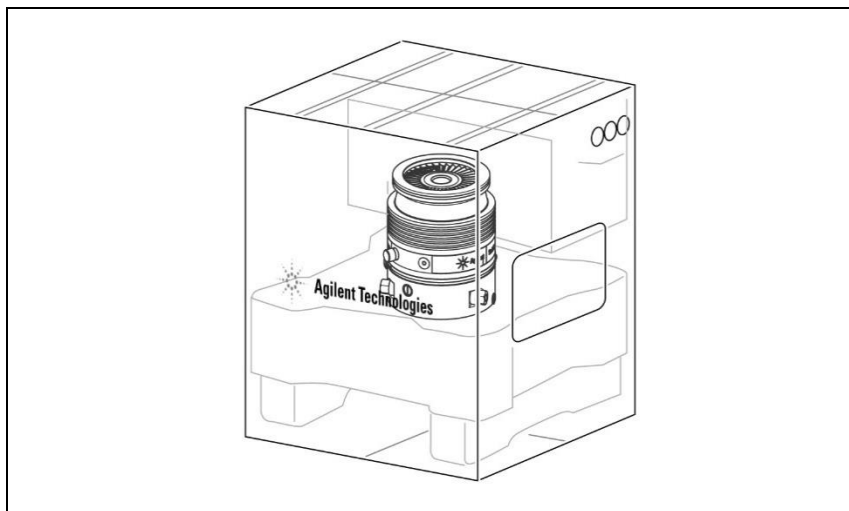

**Figura 1** Imballo del TwisTorr 305-IC

## 1 Istruzioni per l'uso

### Apertura

# Apertura

**ATTENZIONE!** Il 305-IC è un dispositivo elettronico sensibile alle scariche elettrostatiche e, per questo motivo, viene fornito in una custodia protettiva con tappi sulla connessione USB oltre che sulla connessione DB15. Rimuovere questi cappucci protettivi solo quando si collega la pompa al controller.

**ATTENZIONE!** Non rimuovere l'adesivo e il cappuccio protettivo fino a quando non si è pronti per installare la turbopompa sul sistema.



Figura 2

Installare questo dispositivo solo in ambienti chiusi e non utilizzare la pompa in un ambiente esposto ad agenti atmosferici (pioggia, ghiaccio, neve), polvere, gas aggressivi o in ambienti esplosivi o ad alto rischio di incendio.

Durante il funzionamento è necessario rispettare le seguenti condizioni ambientali per evitare la condensa:

- pressione ambiente massima: 2 bar sopra la pressione atmosferica
- temperatura: da +5 °C a +35 °C
- umidità relativa: 0 – 90 % (senza condensa).

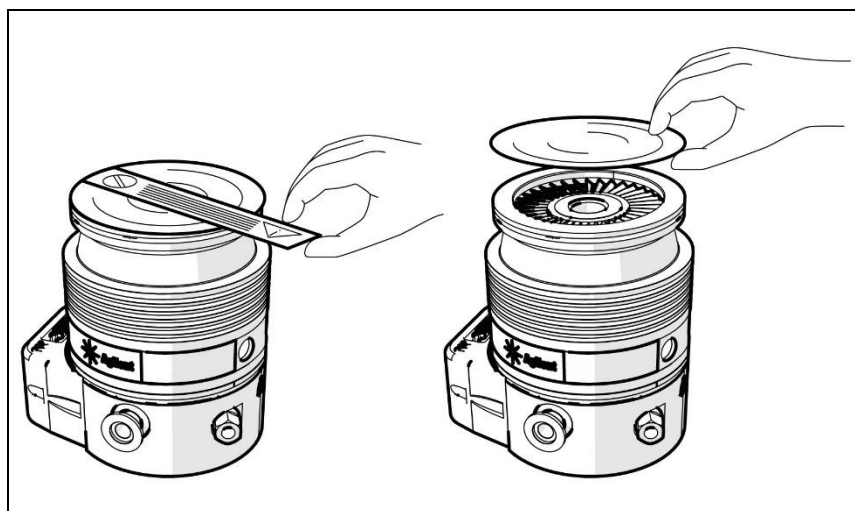
## Riparazione di TwisTorr 305-IC

---

**AVVERTENZA!**



La mancata osservanza di queste istruzioni di installazione potrebbe comportare il distacco della pompa dal sistema in caso di guasto del rotore, con conseguenti danni materiali o lesioni gravi o mortali.

---

TwisTorr 305-IC può essere installato in qualsiasi posizione. Fissare TwisTorr 305-IC in una posizione stabile, montando la flangia di ingresso della turbopompa sulla controflangia del sistema, con una connessione in grado di resistere a una coppia di 1000 Nm attorno al proprio asse.

La turbopompa con flangia di ingresso ConFlat e ISO K deve essere fissata alla camera del vuoto mediante l'apposito hardware Agilent. Per ulteriori dettagli consultare la sezione "Installazione di ConFlat e ISO K".

**ATTENZIONE!**

TwisTorr 305-IC non può essere riparato tramite la sua base.

---

## Collegamento della flangia per alto vuoto

Se il rotore si arresta improvvisamente, la coppia risultante deve essere assorbita dall'hardware che fissa la flangia dell'alto vuoto.

I bulloni o l'hardware devono soddisfare le specifiche seguenti.

---

### **AVVERTENZA!**



È obbligatorio collegare la pompa in modo tale da resistere alla coppia specificata nella sezione "ISTRUZIONI PER L'USO". In particolare, prestare attenzione al design dei morsetti, al materiale dei morsetti e ai bulloni e alla coppia di fissaggio dei bulloni. Utilizzare solo morsetti (o bulloni) di classe ad alta resistenza  $\geq 8,8$ .

---

### **AVVERTENZA!**



Se la pompa viene fissata su una camera a vuoto con flange diverse da quelle consigliate da Agilent, esiste la possibilità che il 305-IC si attorcigli o si strappi nel caso in cui il rotore si arresti improvvisamente. La combinazione di diversi tipi di flangia non è consentita. Agilent non si assume alcuna responsabilità per tutti i danni derivanti da un fissaggio improprio.

---

**1 Istruzioni per l'uso**  
Installazione della flangia ISO-K

## Installazione della flangia ISO-K

Per i collegamenti della flangia ISO-K, fissare le due flange con i morsetti modello IC63250DCMZ o equivalenti, come mostrato nella figura seguente (è possibile utilizzare facoltativamente uno schermo protettivo).

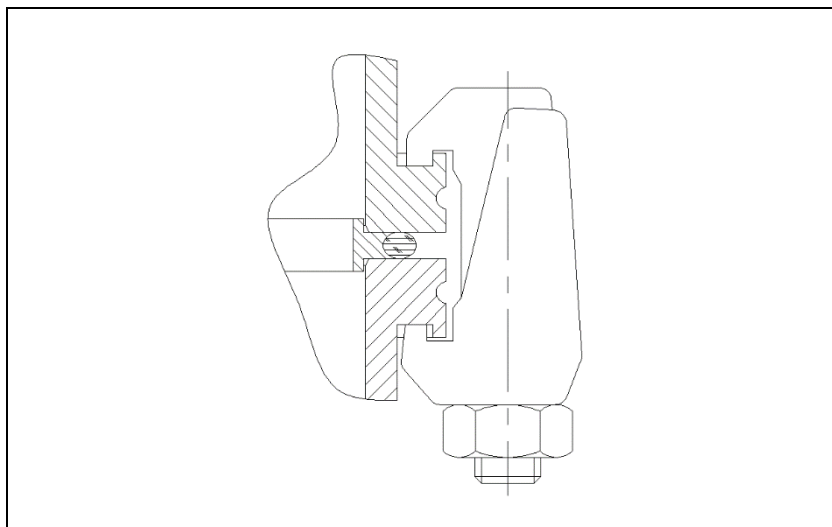

**Figura 3**

Utilizzare il numero richiesto di morsetti artiglio:

- 4 per la flangia ISO 100
- 4 per la flangia ISO 160

Stringere le fascette con una coppia di 22 Nm.

## Installazione della flangia ConFlat

Per i collegamenti delle flange ConFlat, fissare le due flange con le viti come mostrato nella figura seguente (è possibile utilizzare facoltativamente uno schermo protettivo).



Figura 4

Utilizzare il numero richiesto di viti:

- 16 per CFF 6"
- 20 per CFF 8"

Collegare le unità e serrare a turno ciascuna vite. Ripetere il serraggio sequenziale fino a quando le facce della flangia si incontrano. Stringere le viti con una coppia di 20 Nm.

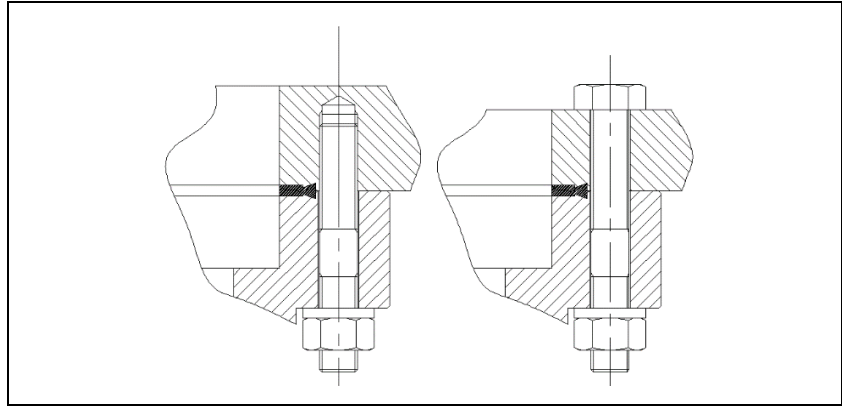
Per la flangia ConFlat consigliamo solo l'uso di bulloni in acciaio ad alta resistenza.

Per facilitare il montaggio e lo smontaggio, è facoltativo applicare il lubrificante Felpro C-100 ad alta temperatura per le filettature delle viti che sporgono dalla flangia e tra i dadi e la flangia.

In alcuni casi, i collegamenti possono essere effettuati solo con il bullone nella parte inferiore.

### ATTENZIONE!

Prestare attenzione quando si serrano dadi e bulloni per evitare di creare ammaccature nella busta.

## 1 Istruzioni per l'uso

### Collegamento della pompa del vuoto anteriore

# Collegamento della pompa del vuoto anteriore

La connessione forzata deve essere effettuata utilizzando la flangia KF 16 NW fornita su TwisTorr 305-IC. Il collegamento alla pompa principale può essere effettuato mediante una pompa o un tubo classificati come vuoto. Se viene utilizzato un tubo rigido, qualsiasi vibrazione generata dalla pompa meccanica deve essere attenuata attraverso l'uso del soffietto.

#### NOTA

TwisTorr 305-IC è caratterizzato da un elevato rapporto di compressione anche per i vapori d'olio. Quando si utilizza una pompa meccanica a tenuta d'olio, è consigliabile installare una trappola adatta tra la turbopompa e la pompa del vuoto anteriore per evitare il riflusso di olio o particolato dalle pompe a secco.

---

## Avvio e funzionamento di TwisTorr 305-IC

Per accendere TwisTorr 305-IC tramite il controller di bordo, fornire alla pompa la tensione di alimentazione corretta e agire sui segnali "START" e "INTERLOCK". Una volta riconosciuti questi segnali, il controller avvia la pompa.

### NOTE















- (1) Per trovare la posizione dei pin di ingresso della tensione di alimentazione (su IN/OUT e connettore di alimentazione), nonché i valori ammessi per la tensione di ingresso, consultare la sezione "Specifiche tecniche" e "IN/OUT e alimentazione" di questo manuale di istruzioni.
  - (2) Per trovare la posizione dei pin di ingresso START/STOP e INTERLOCK (sul connettore IN/OUT e connettore di alimentazione), nonché le relative caratteristiche elettriche, fare riferimento a "IN/OUT e alimentazione" sezione di questo manuale di istruzioni.
  - (3) Per trovare dettagli su come collegare i segnali START/STOP e INTERLOCK, fare riferimento alla sezione "Come collegare gli ingressi Open Collector del controller" di questo manuale di istruzioni.
  - (4) TwisTorr 305-IC è dotato di un connettore di accoppiamento DB15, non precablato. Questo connettore di accoppiamento DB15 è adatto per resistere al livello corrente necessario per alimentare il controller ed è pienamente compatibile con il connettore DB15 montato sull'unità di controllo. Può essere utilizzato, dopo un corretto cablaggio, sia per collegare il TwisTorr 305-IC alla fonte di alimentazione sia alle parti accessorie (ventola di raffreddamento, valvole di sfiato) e anche alla comunicazione seriale.
-

## 1 Istruzioni per l'uso

### Avvio e funzionamento di TwisTorr 305-IC

**AVVERTENZA!** Lo stato della pompa verrà visualizzato dai 3 LED sul controller.



LED	SIMBOLO	STATO LED	TON/TOFF	SIGNIFICATO
Verde 		Off		Spento
		On, lampeggiante		305-IC OFF, stato: STOP/WAITING INTERLOCK/FAIL
		On, lampeggiante invers		305-IC ON, velocità target non ancora raggiunta, stato: STARTING (RAMP)/AUTO TUNING
		ON, Luce fissa		305-IC ON, velocità target raggiunta, stato: NORMAL OP.
		On, lampeggiante		305-IC ON, riduzione velocità, stato: BRAKING
Giallo 		Off		Nessun avviso
		ON, Luce fissa		Avviso
Rosso 		Off		Nessun malfunzionamento
		ON, Luce fissa		Malfunzionamento

**NOTA**

- (1) Nel caso in cui venga rilevato un malfunzionamento (LED rosso, ON luce fissa), la pompa non può girare dopo aver ricevuto il comando di avvio. L'utente può risolvere il motivo del malfunzionamento controllando i messaggi di errore tramite comunicazione seriale e facendo riferimento anche all'elenco delle azioni suggerite. Quando viene rilevato un malfunzionamento, l'unità elettronica entra nello stato FAIL; una volta individuato il motivo del guasto, le unità devono ricevere un nuovo comando di avvio per ripristinare lo stato FAIL. Di conseguenza, se il motivo del malfunzionamento è stato risolto, alla ricezione del nuovo comando START, lo stato della luce a led rosso verrà immediatamente spento e il 305 IC funzionerà correttamente, mostrando lo stato (sulla comunicazione seriale. e dalle indicazioni led verdi) che sono appropriate alle condizioni di lavoro attuali (RAMP, NORMAL, ecc.).
- (2) Nel caso in cui venga rilevato un avviso (LED giallo, ON luce fissa), la pompa può girare correttamente al ricevimento del comando di avvio. L'utente può risolvere il motivo dell'avviso controllando i messaggi di errore tramite comunicazione seriale e anche facendo riferimento all'elenco delle azioni suggerite. Al rilevamento di una condizione di avviso, l'unità continua a funzionare senza interruzioni e mostrando lo stato (sulla comunicazione seriale e dalle indicazioni dei led verdi) che è appropriato per le condizioni di lavoro correnti (RAMPA, NORMALE, ecc.) ).  
Questo perché, gli avvisi non sono correlati ad alcuna condizione di blocco per la funzionalità della pompa. Una volta risolto il motivo dell'avviso, la luce a led gialla si spegne immediatamente e, nella maggior parte dei casi, l'utente non deve eseguire ulteriori azioni sul 305 IC Solo in pochissimi casi, al fine di resettare correttamente il segnale di avviso, l'utente deve spegnere l'unità.

**AVVERTENZA!**

L'avvio iniziale della pompa sarà in modalità "SOFT START"; per informazioni dettagliate su questa modalità consultare la sezione dedicata a pagina 42.



## Arresto di TwisTorr 305-IC

Per arrestare 305-IC, non in emergenza, è necessario:

- a) se 305-IC è configurato in REMOTE MODE, e INTERLOCK è impostato su CONTINUOUS MODE, premere quindi i segnali "START" o "INTERLOCK";
- b) se 305-IC è configurato in REMOTE MODE, e INTERLOCK è impostato su IMPULSE MODE, premere quindi il segnale START;
- c) se 305-IC è configurato in SERIAL Mode, inviare quindi un comando di STOP al 305-IC.

## Arresto di emergenza

L'arresto di emergenza può essere ottenuto rimuovendo l'alimentazione.

---

**AVVERTENZA!**



**Questa modalità deve essere utilizzata solo in caso di emergenza. L'uso di questa modalità di arresto potrebbe causare guasti e/o danni alla pompa. L'uso improprio di questa modalità di arresto potrebbe invalidare la garanzia.**

---

## Manutenzione

La manutenzione non è necessaria a meno che il LED giallo non sia acceso. Per verificare l'errore è possibile leggere il codice tramite connessione seriale. Se una pompa rimane ferma per un periodo di tempo prolungato, si consiglia di verificare visivamente la connessione DB15 per assicurarsi che sia priva di ossidazione.

Qualsiasi altra manutenzione deve essere eseguita da personale autorizzato.

---

### AVVERTENZA!



**Prima di eseguire qualsiasi intervento sul sistema, scollegarlo dall'alimentazione, sfiatare la pompa con la valvola di sfiato, attendere che il rotore sia completamente fermo e attendere che la temperatura superficiale della pompa sia inferiore a 50° C.**

---

In caso di guasto della pompa, è possibile utilizzare il servizio di riparazione Agilent o il "servizio di cambio avanzato Agilent", che offre un sistema rigenerato per sostituire il sistema guasto. Il pezzo di ricambio 305-IC viene spedito al momento dell'ordine. Quindi si restituisce il 305-IC non funzionante nella scatola in cui vi era il pezzo di ricambio 305-IC.

### NOTA

Prima di restituire una pompa per la riparazione o il servizio di sostituzione avanzata al produttore, è essenziale completare e inviare all'ufficio vendite locale il modulo "Richiesta di restituzione" allegato al presente manuale di istruzioni. Copia della stessa deve essere inserita nella confezione del sistema prima della spedizione.

---

Se è necessario eliminare un pezzo, assicurarsi che vengano seguite le normative locali per lo smaltimento appropriato.

## Vita del rotore

La resistenza alla fatica del rotore della pompa turbomolecolare 305-IC risultante dalla valutazione teorica è di 405000 cicli di rampa da arresto a piena velocità e ritorno a fine corsa.

Come misura precauzionale, considerando l'utilizzo tipico della pompa e tenendo conto dei limiti di sicurezza, Agilent consiglia di restituire la pompa dopo 17 anni di utilizzo per la manutenzione.

## Soft Start

---

### AVVERTENZA!



Per garantire una corretta lubrificazione dei cuscinetti, la pompa ha un'impostazione predefinita chiamata soft start. Se la pompa è rimasta ferma per un periodo prolungato o all'avvio iniziale, il controller si avvierà automaticamente all'avvio graduale. Questa modalità di funzionamento consente al prodotto di accelerare per un periodo di tempo prolungato.

Questa modalità operativa automatica non può essere disattivata dall'utente. L'utente può eventualmente decidere di avviare il prodotto sempre in "modalità soft start", agendo su un comando seriale appropriato, come specificato di seguito.

---

La modalità "Soft Start" consente la corretta redistribuzione del grasso presente nei cuscinetti, dopo un lungo periodo di inattività.

La modalità "Soft Start" si attiva automaticamente nei seguenti casi:

- 1 Al primo avvio;
  - 2 Dopo 60 giorni dal raggiungimento dell'ultimo momento nella condizione "FULL SPEED".
- 

### AVVERTENZA!



Questa modalità può essere attivata manualmente utilizzando il comando seriale WIN100. WIN 100 non ha alcun effetto sul soft start automatico al primo avvio e dopo 60 giorni dall'ultimo momento in FULL SPEED. Vedi la sezione "Protocollo di Windows".

---

## Pulizia

La superficie esterna del 305-IC può essere pulita solo con un detergente delicato.

## Smaltimento

### Significato del logo "WEEE" presente nelle etichette

Il seguente simbolo viene applicato in conformità con la Direttiva CE WEEE (Rifiuti di apparecchiature elettriche ed elettroniche).

Questo simbolo (**valido solo nei paesi della Comunità europea**) indica che il prodotto a cui si applica NON deve essere smaltito insieme ai normali rifiuti domestici o industriali ma deve essere inviato a un sistema di raccolta differenziata. L'utente finale è quindi invitato a contattare il fornitore del dispositivo, che sia la Capogruppo o un rivenditore, per avviare il processo di raccolta e smaltimento dopo aver verificato i termini e le condizioni di vendita contrattuali.



Per maggiori informazioni consultare:

<http://www.agilent.com/environment/product/index.shtml>

## Servizio Post Vendita

Nel caso in cui un cliente necessiti di un servizio di sostituzione o riparazione avanzato, si prega di contattare il distributore locale o spedire direttamente a:

[vpt-customer@agilent.com](mailto:vpt-customer@agilent.com)

[vpl-customer@agilent.com](mailto:vpl-customer@agilent.com)

È necessario completare il modulo di richiesta di restituzione per restituire la pompa ad Agilent per l'assistenza (fornito alla fine di questo manuale).

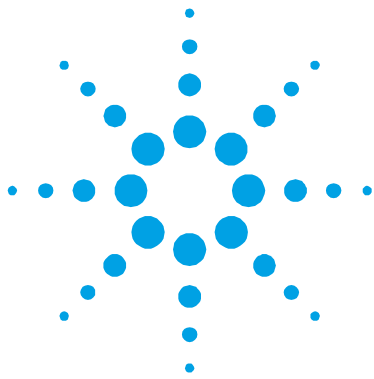

## 2 Gebrauchsanleitung

Über dieses Handbuch	47
Gültigkeit	47
Begriffsbestimmungen und Terminologie	48
Definition von Vorsicht, Warnung und Hinweis	48
Warnsymbole	49
Sicherheit	51
Sachgemäße Verwendung	51
Schutzausrüstung	53
Sicherheitsrichtlinie für Turbomolekularpumpen	55
Transport und Lagerung	56
Produktbeschreibung	57
Installation	58
Vorbereitung zum Einbau	58
Einrichten	60
Montage von TwisTorr 305-IC	62
Anschluss des Hochvakuumflansches	63
Installation des ISO-K-Flansches	64
Installation des ConFlat-Flansches	65
Anschluss der Vorvakuumpumpe	66
Inbetriebnahme und Betrieb vom TwisTorr 305-IC	67
TwisTorr 305-IC stoppen	70
Notausschaltung	70
Wartung	71
Rotordauer	71
Sanftanlauf	72
Reinigung	72
Entsorgung	73
Service	74

## 2 TwisTorr 305-IC Bedienungshandbuch

# Über dieses Handbuch

## Gültigkeit

In diesem Handbuch werden die Anweisungen für die Benutzer des TwisTorr 305-IC aufgeführt, insbesondere in Bezug auf die Begriffe zu Sicherheit, Betrieb und Wartung auf der ersten Ebene, der auf die vom Benutzer zu verantwortenden Wartungsarbeiten beschränkt sind.

Die Wartungsarbeiten, die in den spezifischen Abschnitten mit spezifischen Bestimmungen für den höheren Wartungsgrad (speziell für Wartungsarbeiten geschultes Personal) dargestellt sind, dürfen nicht vom Benutzer durchgeführt werden.

Informationen zur korrekten Installation und zum Starten/Stoppen finden Sie im Kapitel "Installation".

Ausführlichere technische Informationen finden Sie im Kapitel "Betrieb".

### HINWEIS

1. Dieses Handbuch enthält nützliche Informationen, damit alle Mitarbeiter, die den TwisTorr 305-IC verwenden, ihn sicher bedienen und für die gesamte Lebensdauer eine einwandfreie Funktion gewährleisten kann.
  2. Bewahren Sie dieses Handbuch zusammen mit allen zugehörigen Veröffentlichungen an einem für alle Bediener/Wartungspersonal zugänglichen Ort auf.
-

## Begriffsbestimmungen und Terminologie

### Definition von Vorsicht, Warnung und Hinweis

In dieser Gebrauchsanleitung werden wichtige Sicherheitshinweise folgendermaßen farblich hervorgehoben.

---

#### **WARNUNG!**



Die Warnhinweise lenken die Aufmerksamkeit des Bedieners auf eine bestimmte Prozedur oder Praktik, die bei unkorrekter Ausführung schwere Verletzungen hervorrufen können

---

#### **VORSICHT!**

Die Vorsichtshinweise vor bestimmten Prozeduren machen den Bediener darauf aufmerksam, daß bei Nichteinhaltung Schäden an der Anlage entstehen können.

---

#### **HINWEIS**

Hinweise sollen auf wichtige Informationen aufmerksam machen und nähere Informationen zu bestimmten Schritten enthalten.

---

## Warnsymbole

Das Folgende ist eine Liste von Symbolen, die in Verbindung mit den Warnungen auf dem TwisTorr 305-IC angezeigt werden. Die von ihnen beschriebene Gefahr wird ebenfalls angezeigt.

Ein dreieckiges Symbol weist auf eine Warnung hin. Die Bedeutung der Symbole, die neben Warnhinweisen in der Dokumentation oder auf dem Gerät selbst erscheinen können, ist wie folgt:



Gleichstrom



Nicht berühren



Europäische  
Konformitätserklärung



Allgemeine Gefahr



Herstellungsbetrieb



Ausschalten



Einschalten



Schutzerdungsanschluss



## 2 Gebrauchsanleitung

### Warnsymbole

Das folgende Symbol kann auf am Gerät angebrachten Warnschildern verwendet werden. Wenn Sie dieses Symbol sehen, finden Sie in der jeweiligen Betriebs- oder Wartungsanleitung das richtige Verfahren, auf das sich dieses Warnschild bezieht.



Die folgenden Symbole werden zu Ihrer Information auf dem Instrument angezeigt.

	Netz einschalten
	Wenn rot, bedeutet dies eine Fehlfunktion
	Wenn gelb, bedeutet dies eine Warnung
	USB-Anschluss
	Schutzerdungsklemme
	Nicht berühren
J1	Verbindungsstück
NFC	Nahfeldkommunikation (Antenne des Smartphones)
CE	CE-Zertifizierung
	CSA-Zertifizierung
RoHS	Beschränkung gefährlicher Stoffe
	RoHS-Chinazertifizierung
	Elektro- und Elektronikaltgeräte

## Sicherheit

Dieser Abschnitt enthält die in der Maschinenrichtlinie 2006/42/EG vorgeschriebenen Informationen, die für die Einhaltung der Sicherheitsbestimmungen im Allgemeinen und in Bezug auf den spezifischen Einsatz der Maschine von wesentlicher Bedeutung sind.

Die Nichtbeachtung dieser Anweisungen und der anderen in diesem Handbuch enthaltenen Anweisungen kann die in der Konstruktionsphase vorgesehenen Sicherheitsbedingungen ineffizient machen und Unfälle bei den Bedienern der Maschine verursachen.

Agilent Technologies lehnt jede Verantwortung für Schäden an der Maschine oder für die physische Sicherheit des Bedieners oder Dritter ab, die sich aus der Nichtbeachtung der in den technischen Unterlagen angegebenen Sicherheitsregeln ergeben.

## Sachgemäße Verwendung

Dieses Handbuch enthält wichtige Warnungen und Sicherheitshinweise, die beachtet werden müssen, damit das Gerät sicher funktioniert.

Das in dieser Anleitung beschriebene Produkt ist ausschließlich für den in der Anleitung angegebenen Anwendungsbereich bestimmt. Das Handbuch enthält auch Angaben zu den grundlegenden Anforderungen für die Anwendung und den Betrieb des Produkts sowie zu den Sicherheitsmaßnahmen, die zur Gewährleistung eines regelmäßigen Betriebs ergriffen werden können. Agilent Technologies übernimmt keine Garantie oder Verantwortung für Anwendungen, die nicht in diesem Handbuch beschrieben sind oder bei denen die grundlegenden Anforderungen und Sicherheitsmaßnahmen nicht eingehalten werden.

Das Produkt darf nur von qualifiziertem Personal verwendet werden, das in der Lage ist, die erforderlichen Sicherheitsmaßnahmen unter Bedingungen zu treffen, die keine Schäden oder Verletzungen verursachen. Alle mit dem Produkt verwendeten Zubehörteile und Geräte müssen von Agilent Technologies geliefert oder genehmigt werden.

Einstellungs- oder Wartungsarbeiten müssen von einem Fachmann durchgeführt werden, der über die Risiken informiert ist.

Reparaturen am Produkt dürfen ausschließlich von Agilent-autorisiertem Personal durchgeführt werden.

## Unsachgemäße Verwendung

Agilent Technologies lehnt jede Verantwortung ab, die sich aus der unsachgemäßen Benutzung vom TwisTorr 305-IC ergibt.

Bei unsachgemäßer Verwendung verfallen alle Haftungs- und Gewährleistungsansprüche. Unsachgemäße Verwendung ist definiert als:

- Installation der Pumpe mit nicht spezifiziertem Befestigungsmaterial
- Pumpen von ätzenden und oxidierenden Gasen ohne ordnungsgemäßen Spülfluss (siehe Abschnitt „Pumpe für ätzende und oxidierende Gase“)
- Pumpen von explosiven Gasen
- Pumpen von kondensierenden Dämpfen
- Pumpen von Flüssigkeiten
- Pumpen von Pulver
- Betrieb mit unzulässig hohem Gasdurchsatz
- Betrieb mit ungeeignetem Hochvakuumdruck
- Betrieb mit gewählter Gasart, die sich vom tatsächlich verwendeten Gas unterscheidet
- Betrieb mit ungeeignet hoher Wärmeisolation
- Betrieb in unzulässig hohen Magnetfeldern
- Entlüften mit ungeeignet hohen Entlüftungsraten
- Verwendung der Vakuumpumpe zur Druckerzeugung
- Betrieb des Gerätes in Bereichen mit ionisierender Strahlung
- Betrieb in explosionsgefährdeten Bereichen
- Verwendung des Geräts in Systemen, in denen stoßartige Beanspruchungen und Vibrationen oder periodische Kräfte auf das Gerät einwirken.

## Schutz-ausrüstung

Die Schutz-ausrüstung der Bediener, die das Pumpensystem bedienen oder warten, muss immer für die Art des auszuführenden Vorgangs geeignet sein. Darüber hinaus muss es den Sicherheitsanforderungen der in dem Land, in dem die Maschine verwendet wird, geltenden Rechtsvorschriften entsprechen.

Im Allgemeinen muss der Bediener beim Umgang mit dem 305-IC und während der Installation Unfallverhütungsschuhe tragen.



### **WARNUNG!**

#### **Gesundheitsgefahr durch gefährliche Stoffe bei Wartung oder Installation**

Vakuumpumpen, Komponenten oder Betriebsflüssigkeiten können je nach Prozessbesonderheit mit giftigen, reaktiven oder radioaktiven Stoffen verunreinigt sein.

→ Tragen Sie bei Wartungs- und Reparaturarbeiten oder bei einer erneuten Installation angemessene Schutz-ausrüstung.



### **WARNUNG!**

#### **Verletzungsgefahr durch herunterfallende Gegenstände**

Beim Transport von Vakuumpumpen von Hand besteht die Gefahr, dass Lasten verrutschen und herunterfallen.

- Tragen Sie kleine und mittlere Vakuumpumpen mit zwei Händen.
- Alle Geräte, die schwerer als 20 kg sind, sollten mit einer geeigneten Hebevorrichtung transportiert werden.
- Sicherheitsschuhe mit Stahlkappe gemäß Richtlinie EN 347 tragen.

## 2 Gebrauchsanleitung

### Schutzausrüstung



---

#### **VORSICHT!**

#### **Verletzungsgefahr durch scharfe Kanten**

Rotor- und Statorscheiben von Turbopumpen haben sehr scharfe Kanten.

- ➔ Warten Sie vor der Wartung der Pumpe oder vor dem Ein- und Ausbau der Pumpe vom System bis zum vollständigen Stillstand der Pumpe.
  - ➔ Nicht direkt im Hochvakuumflansch betreiben.
  - ➔ Gegebenenfalls Schutzhandschuhe nach EN 420 tragen.
-

## Sicherheitsrichtlinie für Turbomolekularpumpen

Turbomolekularpumpen, wie sie in der folgenden Betriebsanleitung beschrieben sind, enthalten aufgrund der hohen Drehzahl in Kombination mit der spezifischen Masse ihrer Rotoren eine große Menge kinetischer Energie. Bei einer Funktionsstörung eines mechanischen Teils der Pumpe kann die Rotationsenergie an alle Stellen abgegeben werden, an denen die Pumpe befestigt ist.

---

**WARNUNG!**



Um Geräteschäden und Verletzungen des Bedienpersonals zu vermeiden, sind die in diesem Handbuch enthaltenen Installationsanweisungen unbedingt zu beachten!

---

## Transport und Lagerung

Um die maximale Leistung und Zuverlässigkeit von Agilent Turbomolekularpumpen zu gewährleisten, müssen die folgenden Richtlinien beachtet werden, um Kondensation zu vermeiden:

- Beim Versand, Transport und der Lagerung von Pumpen sollten die folgenden Umgebungsbedingungen nicht überschritten werden:
  - Temperaturbereich: Von -40 °C bis 70 °C
  - relativer Luftfeuchtigkeitsbereich: von 0 bis 90% (nicht kondensierend).
- Die Haltbarkeit einer Turbomolekularpumpe beträgt 12 Monate ab Versanddatum.
- Die Turbomolekularpumpen müssen immer sanft gestartet werden, wenn sie vom Kunden zum ersten Mal empfangen und betrieben werden.
- Die Turbomolekularpumpen müssen nach einer gewissen Zeit von 60 Tage von Inaktivität der Pumpe immer sanft gestartet werden.

### **VORSICHT!**

Wenn aus irgendeinem Grund die Haltbarkeitsdauer überschritten wird, muss die Pumpe an das Werk zurückgeschickt werden. Bitte wenden Sie sich an den lokalen Agilent Vacuum Vertriebs- und Servicevertreter, um weitere Informationen zu erhalten.

---

## Produktbeschreibung

Dieses Gerät ist für den professionellen Gebrauch und für den professionellen Gebrauch bestimmt.

TwisTorr 305-IC ist eine Turbomolekularpumpe für Hoch- und Ultrahochvakuumanwendungen, die alle Arten von nicht korrosiven und oxidierenden Gasen oder Gasverbindungen fördern kann.

Die Pumpwirkung wird durch eine Hochgeschwindigkeitsturbine (max. 60600 U/min) erzielt, die von einem Hochleistungselektromotor angetrieben wird.

Sie ist frei von Verunreinigungen und eignet sich daher für Anwendungen, die ein „sauberes“ Vakuum erfordern.

Detaillierte Informationen entnehmen Sie dem Abschnitt „Technische Informationen“.

## Installation

### Vorbereitung zum Einbau

TwisTorr 305-IC wird in einer speziellen Schutzverpackung geliefert. Wenden Sie sich an Ihr lokales Verkaufsbüro, wenn dies Anzeichen von Schäden zeigt, die während des Transports aufgetreten sein können.

Vermeiden Sie plötzliche Stöße auf den 305-IC, die durch Herunterfallen verursacht werden können. Bewahren Sie den Verpackungskarton auf, um ihn bei längerer Lagerung oder beim Versand wieder verwenden zu können.

Entsorgen Sie das Verpackungsmaterial nicht auf unbefugte Weise. Das Material ist zu 100% recycelbar und entspricht der EG-Richtlinie 94/62 und nachfolgenden Änderungen.

#### **VORSICHT!**

Um Ausgasungsprobleme zu vermeiden, verwenden Sie keine bloßen Hände, um Bauteile zu handhaben, die Vakuum ausgesetzt sind. Verwenden Sie immer Handschuhe oder einen anderen geeigneten Schutz.

---

#### **HINWEIS**

Normale Umwelteinflüsse können den TwisTorr 305-IC nicht beschädigen. Trotzdem ist es ratsam, es bis zum Einbau in das System in der Plastiktüte aufzubewahren, um jegliche Verschmutzung durch Staub zu vermeiden.

---

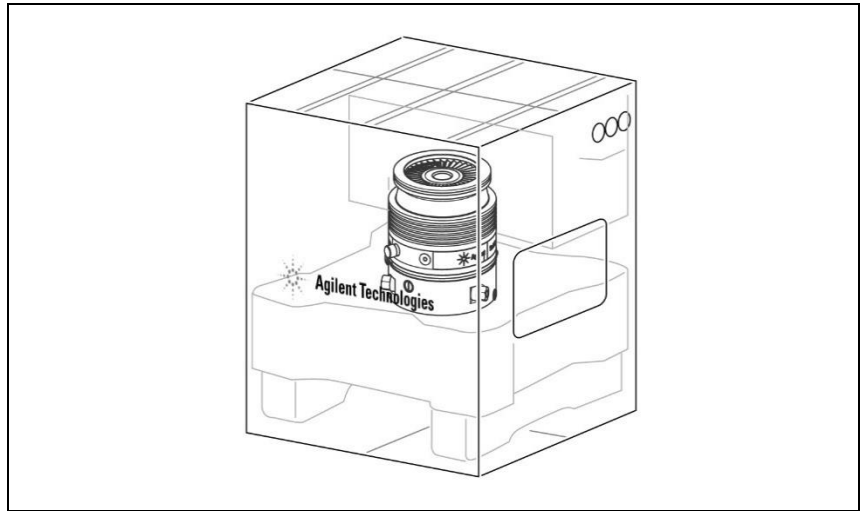

**Abbildung 1** TwisTorr 305-IC-Verpackung

## Einrichten

**VORSICHT!** 305-IC ist ein gegen elektrostatische Entladungen empfindliches elektronisches Gerät und wird bis zu diesem Zeitpunkt in einer Schutzhülle mit Kapfen am USB-Anschluss sowie am DB15-Anschluss geliefert. Entfernen Sie diese Schutzkappen nur, wenn Sie die Pumpe an den Controller anschließen.

**VORSICHT!** Entfernen Sie den Klebstoff und die Schutzkappe erst, wenn Sie bereit sind, die Turbopumpe am System zu installieren.



Abbildung 2

Stellen Sie das Gerät nur in Innenräumen auf und verwenden Sie die Pumpe nicht in Umgebungen, die Witterungseinflüssen (Regen, Eis, Schnee), Staub, aggressiven Gasen oder explosionsgefährdeten Umgebungen ausgesetzt sind.

Während des Betriebs müssen folgende Umgebungsbedingungen eingehalten werden, um Kondensation zu vermeiden:

- Maximaler Umgebungsdruck: 2 bar über dem atmosphärischen Druck
- Temperatur: von +5 °C bis +35 °C
- Relative Feuchtigkeit: 0-90% (nicht kondensierend).

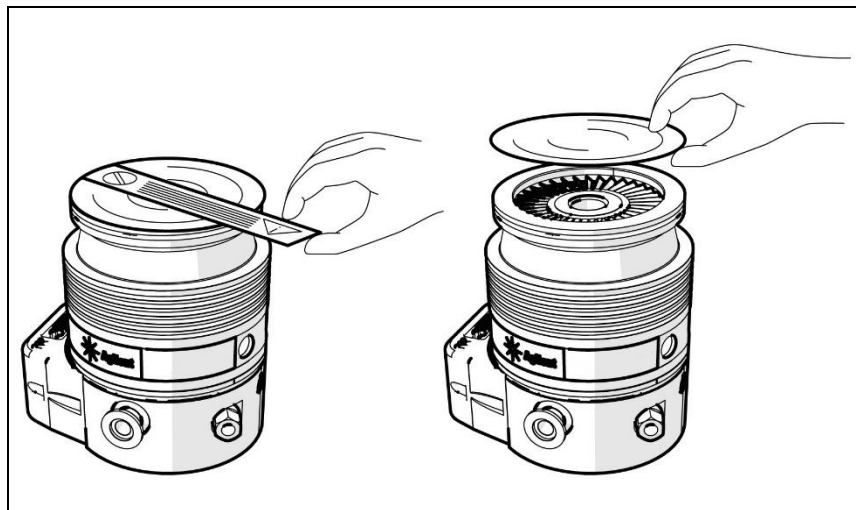
## Montage von TwisTorr 305-IC

---

**WARNUNG!**



Die Nichtbeachtung dieser Installationsanweisungen kann dazu führen, dass sich die Pumpe bei einem Rotorausfall vom System löst, was zu Sachschäden oder schweren oder tödlichen Verletzungen führen kann.

---

TwisTorr 305-IC kann in jeder Position installiert werden. Befestigen Sie den TwisTorr 305-IC in einer stabilen Position und montieren Sie den Einlassflansch der Turbopumpe am Gegenflansch des Systems, wobei die Verbindung ein Drehmoment von 1000 Nm um deren Achse aushalten kann.

Die Turbopumpe mit ConFlat- und ISO K-Einlassflansch muss mit den entsprechenden Agilent-Teilen an der Vakuumkammer befestigt werden. Weitere Einzelheiten entnehmen Sie dem Abschnitt „Installation von ConFlat und ISO K“.

**VORSICHT!**

TwisTorr 305-IC kann nicht mit seiner Basis befestigt werden

---

## Anschluss des Hochvakuumflansches

Wenn der Rotor plötzlich stoppt, muss das resultierende Drehmoment von der Befestigung des Hochvakuumflansches aufgenommen werden.

Schrauben oder Kleinteile müssen den unten angegebenen Spezifikationen entsprechen.

---

**WARNUNG!**



Die Pumpe muss so angeschlossen werden, dass sie dem im Abschnitt „GEBRAUCHSANLEITUNG“ angegebenen Drehmoment standhält. Achten Sie insbesondere auf die Ausführung der Klemmen, das Material der Klemmen und Schrauben und den Anzugmoment der Schrauben.

Verwenden Sie nur Klemmen (oder Schrauben) mit hohem Widerstand  $\geq 8.8$ .

---

**WARNUNG!**



Wenn die Pumpe an einer Vakuumkammer mit Flanschen befestigt ist, die von den von Agilent empfohlenen Flanschen abweichen, besteht die Möglichkeit, dass sich der 305-IC dreht oder abreißt, falls der Rotor plötzlich stoppt. Die Kombination verschiedener Flanschtypen ist nicht zulässig. Agilent übernimmt keine Haftung für alle Schäden, die durch unsachgemäße Befestigung entstehen.

---

## 2 Gebrauchsanleitung

### Installation des ISO-K-Flansches

# Installation des ISO-K-Flansches

Befestigen Sie bei ISO-K-Flanschverbindungen die beiden Flansche mit den Klemmen Modell IC63250DCMZ oder einem gleichwertigen Element, wie in der folgenden Abbildung dargestellt (optional kann ein Schutzgitter verwendet werden).

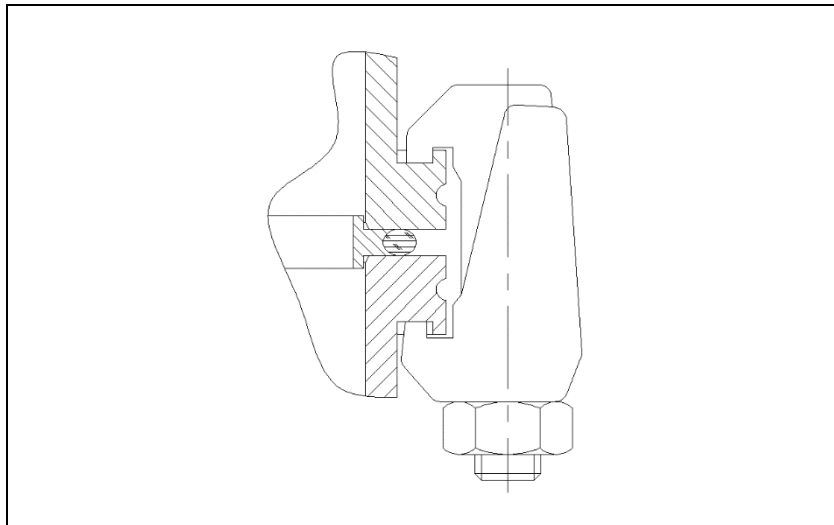

**Abbildung 3**

Verwenden Sie die erforderliche Anzahl von Klauenklemmen:

- 4 für ISO 100 Flansch
- 4 für ISO 160 Flansch

Ziehen Sie die Klauenklemmen mit einem Drehmoment von 22 Nm an.

## Installation des ConFlat-Flansches

Befestigen Sie bei ConFlat-Flanschverbindungen die beiden Flansche mit den Schrauben wie in der folgenden Abbildung gezeigt (optional kann ein Schutzgitter verwendet werden).

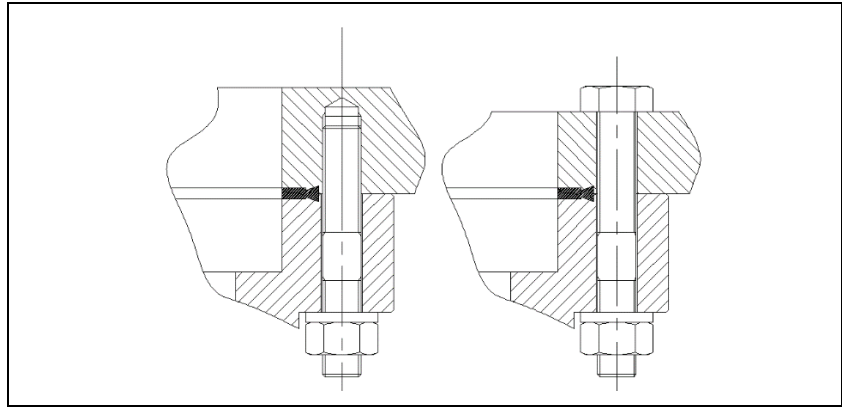

**Abbildung 4**

Verwenden Sie die erforderliche Anzahl von Schrauben:

- 16 für CFF 6"
- 20 für CFF 8"

Befestigen Sie die Einheiten und ziehen Sie jede Schraube der Reihe nach an. Wiederholen Sie das sequenzielle Anziehen, bis die Flanschflächen einander anschlagen. Ziehen Sie die Schrauben mit einem Drehmoment von 20 Nm an. Für ConFlat-Flansche empfehlen wir nur die Verwendung von hochfesten Stahlschrauben.

Um die Montage und Demontage zu erleichtern, kann optional Felpro C-100 Hochtemperaturschmiermittel auf, die aus dem Flansch und zwischen den Muttern und dem Flansch herausragenden Schraubengewinde aufgetragen werden.

In einigen Fällen können die Verbindungen nur mit dem Bolzen in der unteren Seite hergestellt werden.

**VORSICHT!**

Gehen Sie beim Anziehen der Schrauben und Muttern vorsichtig vor, um Beulen am Gehäuse zu vermeiden.

## 2 **Gebrauchsanleitung**

### Anschluss der Vorvakuumpumpe

## **Anschluss der Vorvakuumpumpe**

Der Vorleitungsanschluss sollte mit dem KF 16 NW-Flansch erfolgen, der auf dem TwisTorr 305-IC bereitgestellt wird. Die Verbindung zur Vorpumpe kann über einen Vakuumschlauch oder ein Vakuumrohr hergestellt werden. Wenn ein starres Rohr verwendet wird, müssen Vibrationen, die von der mechanischen Pumpe erzeugt werden, mit einem Faltenbalg gedämpft werden.

#### **HINWEIS**

TwisTorr 305-IC zeichnet sich durch sein hohes Verdichtungsverhältnis auch für Öldämpfe aus. Bei Verwendung einer mechanisch ölgedichteten Pumpe ist es ratsam, zwischen der Turbopumpe und der Vorvakuumpumpe einen geeigneten Abscheider anzubringen, um ein Zurückströmen von Öl oder Partikeln aus trockenen Pumpen zu verhindern.

---

## Inbetriebnahme und Betrieb vom TwisTorr 305-IC

Um den TwisTorr 305-IC über die integrierten Controller einzuschalten, versorgen Sie die Pumpe mit der richtigen Versorgungsspannung und wirken Sie auf die Signale „START“ und „INTERLOCK“ ein. Sobald diese Signale erkannt werden, startet die Steuerung die Pumpe.

### ANMERKUNGEN

- (1) Die Position der Versorgungsspannungseingangsstifte (an IN/OUT und Netzteilanschluss) sowie die zulässigen Eingangsspannungswerte entnehmen Sie dem Abschnitt „Technische Daten“ und unter „IN/OUT“ und „Stromversorgung“ in dieser Bedienungsanleitung.
  - (2) Die Position der START STOP- und INTERLOCK-Eingangsstifte (am IN/OUT- und Netzteilanschluss) sowie die zugehörigen elektrischen Kenndaten finden Sie unter dem Abschnitt „IN/OUT und Netzteil“ dieser Bedienungsanleitung.
  - (3) Einzelheiten zum Anschließen der Signale START/STOP und INTERLOCK finden Sie im Abschnitt „Anschließen der Open Collector-Eingänge des Controllers“ in dieser Bedienungsanleitung.
  - (4) TwisTorr 305-IC ist mit einem DB15-Gegenstecker ausgestattet, der nicht vorverdrahtet ist. Dieser DB15-Gegenstecker ist für die Stromversorgung des Controllers geeignet und voll kompatibel mit dem DB15-Stecker, der an der Steuereinheit montiert ist. Nach ordnungsgemäßer Verdrahtung kann der TwisTorr 305-IC sowohl an die Versorgungsquelle als auch an die Zubehörteile (Lüfter, Entlüftungsventile) und auch an die serielle Schnittstelle angeschlossen werden.
-













## 2 Gebrauchsanleitung

### Inbetriebnahme und Betrieb vom TwisTorr 305-IC

**WARNUNG!**

Der Status der Pumpe wird durch die 3 LEDs am Controller angezeigt.



LED	SYMBOL	LED-STATUS	TON/TOFF	BEDEUTUNG
Grün 		Aus	—	Ausschalten
		Ein, blinkend		305-IC OFF, Status: STOPP/WARTEN VERRIEGELUNG/FEHLER
		Ein, invers blinkt		305-IC ON, Zielgeschwindigkeit noch nicht erreicht, Status: STARTEN (RAMP)/AUTO TUNING
		Ein, Dauerhaftes Licht		305-IC ON, Zielgeschwindigkeit erreicht, Status: NORMAL OP.
		Ein, blinkend		305-IC ON, Geschwindigkeitsreduzierung, Status: BREMSEN
Gelb 		Aus	—	Keine Warnung
		Ein, Dauerhaftes Licht		Warnung
Rot 		Aus	—	keine Funktionsstörung
		Ein, Dauerhaftes Licht		Störung

**HINWEIS**

- (1) Wird eine Störung festgestellt (rote LED, leuchtet durchgehend), kann die Pumpe nach Erhalt des Startbefehls nicht anlaufen. Der Benutzer kann den Grund für die Störung feststellen, indem er die Fehlermeldungen über die serielle Kommunikation und die Liste der vorgeschlagenen Maßnahmen überprüft. Wird eine Störung erkannt, geht die Elektronik in den Zustand FEHLER über; Sobald der Grund für den Fehler behoben wurde, müssen die Einheiten einen neuen Startbefehl empfangen, um den Status FEHLER zurückzusetzen. Wenn der Grund für die Störung behoben wurde, wird der Status der roten LED-Leuchte beim Empfang des neuen START-Befehls sofort ausgeschaltet und der 305 IC wird ordnungsgemäß betrieben und zeigt den Status an (auf der seriellen Kommunikationsschnittstelle und durch die grüne LED-Anzeige), die dem aktuellen Arbeitszustand (RAMP, NORMAL usw.) entspricht.
- (2) Wenn eine Warnung (gelbe LED, dauerhaftes Licht) erkannt wird, kann die Pumpe nach Erhalt des Startbefehls ordnungsgemäß anlaufen. Der Benutzer kann den Grund für die Warnung ermitteln, indem er die Fehlermeldungen über die serielle Kommunikation überprüft und auch auf die Liste der vorgeschlagenen Maßnahmen Bezug nimmt. Nach dem Erkennen eines Warnzustands arbeitet das Gerät ohne Unterbrechungen weiter und zeigt den Status (auf der seriellen Schnittstelle und durch die grünen LED-Anzeigen) an, der dem aktuellen Arbeitszustand (RAMP, NORMAL usw.) entspricht.  
Dies liegt daran, dass Warnungen nicht mit Blockierungsbedingungen für die Pumpenfunktionalität zusammenhängen. Sobald der Grund für die Warnung behoben wurde, erlischt die gelbe LED sofort, und in den meisten Fällen muss der Benutzer nur in wenigen Fällen weitere Aktionen auf dem 305 IC ausführen; um das Warnsignal richtig zurückzusetzen, muss der Benutzer das Gerät ausschalten.

**WARNUNG!**



**Der erste Start der Pumpe erfolgt im „Sanftanlauf“ - Modus. Ausführliche Informationen zu diesem Modus finden Sie im entsprechenden Abschnitt auf Seite 72.**

## TwisTorr 305-IC stoppen

Um den 305-IC nicht im Notfall anzuhalten, müssen Sie:

- a) Wenn der 305-IC im FERNBETRIEBSART konfiguriert ist und die VERRIEGELUNG auf DAUERBETRIEB eingestellt ist, öffnen Sie die Signale „START“ oder „VERRIEGELUNG“.
- b) Wenn der 305-IC im FERNBETRIEBSART konfiguriert ist und die VERRIEGELUNG auf IMPULSBETRIEB eingestellt ist, öffnen Sie das START-Signal.
- c) Wenn der 305-IC im SERIAL-Modus konfiguriert ist, senden Sie einen STOPP-Befehl an den 305-IC.

## Notausschaltung

Die Notausschaltung kann durch Entfernen der Stromversorgung erreicht werden.

---

**WARNUNG!**



**Diese Betriebsart ist nur im Notfall zu verwenden. Die Verwendung dieses Stoppmodus kann zu Fehlern und/oder Schäden an der Pumpe führen. Die unsachgemäße Verwendung dieses Stoppmodus kann zum Erlöschen der Garantie führen.**

---

## Wartung

Eine Wartung ist nur erforderlich, wenn die gelbe LED leuchtet. Um den Fehler zu überprüfen, können Sie den Code über eine serielle Verbindung lesen. Wenn eine Pumpe längere Zeit stillsteht, wird empfohlen, die DB15-Verbindung einer Sichtprüfung zu unterziehen, um sicherzustellen, dass sie frei von Oxidation ist. Alle anderen Wartungsarbeiten müssen von autorisiertem Personal durchgeführt werden.

---

### WARNUNG!



**Bevor Sie Arbeiten an der Anlage ausführen, trennen Sie diese von der Stromversorgung, entlüften Sie die Pumpe mit dem Entlüftungsventil, warten Sie, bis der Rotor vollständig stillsteht und bis die Oberflächentemperatur der Pumpe unter 50° C liegt.**

---

Falls die Pumpe ausfällt, können Sie den Agilent-Reparaturdienst oder den „erweiterten Austauschservice von Agilent“ verwenden, mit dem Sie ein überarbeitetes System erhalten, um das ausgefallene System zu ersetzen. Der Austausch 305-IC wird versendet, wenn die Bestellung aufgegeben wird. Sie geben dann den fehlerhaften 305-IC in der Verpackung zurück, mit dem der Austausch-305-IC vorgenommen wird.

### HINWEIS

Bevor Sie eine Pumpe zur Reparatur oder zum vorzeitigen Austausch an den Hersteller zurücksenden, müssen Sie unbedingt das dieser Bedienungsanleitung beigefügte Formular „Rückgabeantrag“ ausfüllen und an das örtliche Verkaufsbüro senden. Eine Kopie davon muss vor dem Versand in die Verpackung des Systems eingelegt werden.

---

Wenn ein System verschrottet werden muss, stellen Sie sicher, dass die örtlichen Vorschriften für eine angemessene Entsorgung befolgt werden.

## Rotordauer

Die sich aus der theoretischen Bewertung ergebende Ermüdungsbeständigkeit des 305-IC-Turbomolekularpumpenrotors beträgt 405000 Ramp-Up-Zyklen von Stopp zu voller Geschwindigkeit und zurück zu Stopp. Aus Sicherheitsgründen empfiehlt Agilent, die Pumpe unter Berücksichtigung der typischen Verwendung der Pumpe und unter Berücksichtigung der Sicherheitsgrenzen nach 17 Jahren zur Wartung zurückzugeben.

## Sanftanlauf

---

**WARNUNG!**



Um eine ordnungsgemäße Schmierung der Lager zu gewährleisten, hat die Pumpe eine Standardeinstellung, die als Sanftanlauf bezeichnet wird. Wenn die Pumpe längere Zeit gestanden hat oder beim ersten Start, startet die Steuerung automatisch im Sanftanlauf. Diese Betriebsart bringt das Produkt über einen längeren Zeitraum auf den neuesten Stand.

Diese automatische Betriebsart kann vom Benutzer nicht deaktiviert werden. Der Benutzer kann möglicherweise entscheiden, das Produkt immer im „Softanlauf-Modus“ zu starten, indem er auf einen entsprechenden seriellen Befehl reagiert, wie unten angegeben.

---

Der „Softanlauf“ -Modus ermöglicht die korrekte Umverteilung des in den Lagern vorhandenen Fetts nach einer langen Zeit der Inaktivität.

Der Modus „Softanlauf“ wird in folgenden Fällen automatisch aktiviert:

- 1 Beim ersten Start;
  - 2 Nach 60 Tagen ab dem letzten Moment, an dem ein Zustand „VOLLGESCHNWNDIGKEIT“ erreicht wurde.
- 

**WARNUNG!**



Dieser Modus kann manuell mit dem seriellen Befehl WIN100 aktiviert werden.

WIN 100 hat beim ersten Start und danach keine Auswirkung auf den automatischen Sanftanlauf und nach 60 Tagen ab dem letzten Moment in VOLLGESCHWINDIGKEIT.

Siehe Abschnitt „Windows-Protokoll“.

---

## Reinigung

Die Außenfläche des 305-IC darf nur mit einem milden Reinigungsmittel gereinigt werden.

## Entsorgung

### Bedeutung des "WEEE" -Logos auf den Etiketten

Das folgende Symbol wird in Übereinstimmung mit der EG-Richtlinie über Elektro- und Elektronik-Altgeräte (WEEE) verwendet. Dieses Symbol (**gültig nur in Ländern der Europäischen Gemeinschaft**) weist darauf hin, dass das betreffende Produkt NICHT zusammen mit normalem Haushalts- oder Industriemüll entsorgt werden darf, sondern einem getrennten Abfallsammelsystem zugeführt werden muss. Der Endabnehmer sollte daher den Lieferanten des Geräts - d.h. Die Muttergesellschaft oder den Wiederverkäufer - kontaktieren, um den Entsorgungsprozess zu starten, nachdem er die Verkaufsbedingungen geprüft hat.



Weitere Informationen finden Sie unter:

<http://www.agilent.com/environment/product/index.shtml>

## Service

Sollte ein Kunde einen erweiterten Austausch- oder Reparaturservice benötigen, wenden Sie sich bitte an den örtlichen Händler oder direkt an die Email-Adresse

[vpt-customer@agilent.com](mailto:vpt-customer@agilent.com)

[vpl-customer@agilent.com](mailto:vpl-customer@agilent.com)

Das Ausfüllen des Rücksendeformulars ist erforderlich, um die Pumpe zur Wartung an Agilent zurückzusenden (am Ende dieses Handbuchs angegeben).



## Mode d'emploi

À propos de ce manuel	77
Validité	77
Définitions et terminologie	78
Définition des termes « Attention », « Avertissement » et « Note »	78
Symboles d'avertissement	79
Sécurité	81
Utilisation appropriée	81
Utilisation inappropriée	82
Équipement de protection	83
Directive de sécurité pour les pompes turbomoléculaires	85
Transport et entreposage	86
Description du produit	87
Installation	88
Préparation pour l'installation	88
Configuration	90
Montage du TwisTorr 305-IC	92
Raccordement de la bride à vide élevé	93
Installation de la bride ISO-K	94
Installation de la bride ConFlat	95
Raccordement de la bride à vide préliminaire	96
Démarrage et utilisation du TwisTorr 305-IC	97
Arrêt du TwisTorr 305-IC	100
Arrêt d'urgence	100
Entretien	101
Durée de vie du rotor	101
Démarrage progressif	102
Nettoyage	102
Mise au rebut	103
Service	104

### **3 TwisTorr 305-IC Notice de mode d'emploi**

## À propos de ce manuel

### Validité

Le présent manuel contient les instructions pour les utilisateurs du TwisTorr 305-IC, en particulier les notions de sécurité, d'exploitation et d'entretien de premier niveau, limitées aux opérations de maintenance dont l'utilisateur est responsable.

Les opérations d'entretien, illustrées dans les sections correspondantes, avec les dispositions spécifiques relatives au niveau supérieur d'entretien (personnel spécialement formé pour les opérations d'entretien) ne doivent pas être effectuées par l'utilisateur.

Pour une installation et un démarrage/arrêt corrects, veuillez vous reporter au chapitre « Installation ».

Pour une utilisation technique plus détaillée, veuillez vous référer au chapitre « Opérations ».

#### NOTE

1. Le présent contient des informations utiles pour que tout le personnel utilisant le TwisTorr 305-IC puisse l'exploiter en toute sécurité et garantir une efficacité parfaite, pendant toute sa durée de vie.
  2. Conserver le présent manuel, ainsi que toutes les publications connexes, dans un endroit accessible et connu de tous les opérateurs/du personnel chargé(s) de l'entretien.
-

## Définitions et terminologie

### Définition des termes « Attention », « Avertissement » et « Note »

Certaines références importantes du présent manuel sont mises en évidence et encadrées en couleurs contrastées.

---

#### **AVERTISSEMENT!**



Les messages d'avertissement attirent l'attention de l'opérateur sur une procédure ou une pratique particulière qui, si elle n'est pas exécutée correctement, pourrait entraîner des blessures graves.

---

#### **ATTENTION !**

Des messages de mise en garde s'affichent avant les procédures qui, si elles ne sont pas respectées, pourraient endommager l'équipement.

---

#### **NOTE**

Les notes visent à attirer l'attention sur des renseignements importants et à fournir plus de détails sur des étapes précises.

---

## Symboles d'avertissement

Voici une liste de symboles qui apparaissent en conjonction avec les avertissements sur le TwisTorr 305-IC. Le danger qu'ils décrivent est également illustré.

Le symbole triangulaire indique un avertissement. Les significations des symboles qui peuvent apparaître à côté des avertissements dans la documentation ou sur l'appareil lui-même sont les suivantes :



Courant continu



Ne pas toucher



Déclaration européenne  
de conformité



Danger générique



Site de fabrication



Mise hors tension



Mise sous tension



Borne de mise à la  
terre de protection

### 3 Mode d'emploi

#### Symboles d'avertissement

Le symbole suivant peut être utilisé sur les étiquettes d'avertissement apposées sur l'appareil. Lorsque vous voyez ce symbole, reportez-vous au manuel d'utilisation ou d'entretien correspondant pour connaître la procédure correcte visée par cette étiquette d'avertissement.



Les symboles suivants apparaissent sur l'appareil pour votre information.

	Alimentation secteur activée
	Si rouge, cela signifie un dysfonctionnement
	Si jaune, cela signifie une alerte
	Port USB
	Borne de mise à la terre de protection
	Ne pas toucher
J1	Connecteur principal
NFC	Communication en champ proche (antenne de smartphone)
CE	Certification CE
	Certification CSA
RoHS	Restriction de la certification des substances dangereuses
	Certification RoHS Chine
	Déchets d'équipements électriques et électroniques

## Sécurité

Cette section contient les informations prescrites par la directive Machines 2006/42/CE, qui est essentielle à la conformité et au respect des règles de sécurité en général ainsi qu'à l'utilisation spécifique de la machine.

Le non-respect de ces instructions et des autres instructions contenues dans le présent manuel peut rendre inefficaces les conditions de sécurité prévues dans la phase de conception et causer des accidents à ceux qui utilisent la machine. Agilent Technologies décline toute responsabilité pour les dommages causés à la machine ou pour la sécurité physique de l'opérateur ou des tiers résultant du non-respect des règles de sécurité indiquées dans la documentation technique.

## Utilisation appropriée

Le présent manuel contient des avertissements importants et des instructions de sécurité à respecter pour que l'appareil puisse fonctionner en toute sécurité.

Le produit décrit dans le présent manuel est destiné exclusivement au domaine d'application spécifié dans les instructions. Le manuel fournit également des indications concernant les exigences essentielles pour l'application et le fonctionnement du produit ainsi que les mesures de sécurité qui peuvent être adoptées pour garantir un fonctionnement régulier. Agilent Technologies ne fournit aucune garantie ou n'assume aucune responsabilité pour des applications autres que celles décrites dans le présent manuel ou dans lesquelles les exigences essentielles et les mesures de sécurité ne sont pas respectées.

Le produit ne doit être utilisé que par un personnel qualifié capable de prendre les mesures de sécurité nécessaires dans des conditions qui ne causent pas de dommages ou de blessures. Tous les accessoires et équipements utilisés avec le produit doivent être fournis ou approuvés par Agilent Technologies.

Toute opération de réglage ou de maintenance doit être effectuée par un technicien professionnel informé des risques.

Les réparations du produit doivent être effectuées exclusivement par le personnel autorisé d'Agilent.

## Utilisation inappropriée

Agilent Technologies décline toute responsabilité en raison de l'utilisation inappropriée du TwisTorr 305-IC.

Une utilisation inappropriée entraînera l'annulation de toutes les créances et garanties. Une utilisation inappropriée est définie comme suit :

- installation de la pompe avec un matériau de montage non spécifié ;
- pompage des gaz corrosifs et oxydants avec débit de purge approprié (voir la section « Pompe utilisée avec des gaz corrosifs et oxydants ») ;
- pompage des gaz explosifs ;
- pompage des vapeurs de condensation ;
- pompage des liquides ;
- pompage de la poussière ;
- fonctionnement avec débit de gaz élevé ;
- fonctionnement avec des pressions de vide élevées ;
- fonctionnement avec la modalité de gaz sélectionnée différente du gaz réellement utilisé ;
- fonctionnement avec des niveaux élevés d'entrée de chaleur isolée ;
- fonctionnement dans des champs magnétiques élevés incorrects ;
- évacuation avec des taux d'évacuation élevés inappropriés ;
- utilisation de la pompe à vide pour générer de la pression ;
- fonctionnement de l'appareil dans les zones à rayonnement ionisant ;
- fonctionnement dans des zones potentiellement explosives ;
- utilisation du dispositif dans des systèmes dans lesquels des contraintes et des vibrations de type choc ou des forces périodiques affectent le dispositif.

## Équipement de protection

L'équipement de protection des exploitants qui opèrent ou effectuent l'entretien du système de pompage doit toujours être adéquat pour le type d'utilisation en cours. En outre, il doit être conforme aux exigences de sécurité de la législation en vigueur dans le pays où la machine est utilisée.

En général, l'exploitant doit porter des chaussures de prévention des accidents lors de la manipulation et de l'installation du 305-IC.



**AVERTISSEMENT !!** **Danger pour la santé par des substances dangereuses pendant l'entretien ou l'installation**



Selon la particularité du procédé, les pompes à vide, composants ou fluides d'exploitation peuvent être contaminés par des substances toxiques, réactives ou radioactives.

→ Porter un équipement de protection adéquat pendant l'entretien et les réparations ou en cas de réinstallation.



**AVERTISSEMENT !!** **Risque de blessure par chute d'objets**



Lors du transport manuel des pompes à vide, il y a un danger causé par les charges qui glissent et tombent.

- Transporter les petites et moyennes pompes à vide avec les deux mains.
- Tout équipement de plus de 20 kg doit être transporté à l'aide d'un dispositif de levage approprié.
- Porter des chaussures de sécurité avec embout en acier conformément à la directive EN 347.

### 3 Mode d'emploi

Utilisation appropriée



---

**ATTENTION !** **Risque de blessure par objets tranchants**

Les disques de rotor et de stator des turbopompes ont des bords très tranchants.

- ➔ Avant de procéder à l'entretien de la pompe ou avant tout montage/démontage de la pompe du système, attendre l'arrêt complet de la pompe.
  - ➔ Ne pas exploiter directement à l'intérieur de la bride à vide élevé.
  - ➔ Si cela est nécessaire, porter des gants de protection conformément à la norme EN 420.
-

## Directive de sécurité pour les pompes turbomoléculaires

Les pompes turbomoléculaires décrites dans le manuel d'utilisation suivant contiennent une grande quantité d'énergie cinétique en raison de la vitesse de rotation élevée en combinaison avec la masse spécifique de leurs rotors.

En cas de dysfonctionnement d'une partie mécanique de la pompe, l'énergie de rotation peut être libérée sur la pompe à laquelle elle est fixée.

---

**AVERTISSEMENT !!**

**Pour éviter d'endommager l'équipement et de blesser le personnel exploitant, les instructions d'installation fournies dans le présent manuel doivent être rigoureusement respectées !**

---

## Transport et entreposage

Afin de garantir le niveau maximal de performance et de fiabilité des pompes turbomoléculaires Agilent, les directives suivantes doivent être respectées pour éviter la condensation :

- lors de la livraison, du déplacement et de l'entreposage des pompes, les spécifications environnementales suivantes ne doivent pas être dépassées :
  - plage de température : -40 °C à 70 °C
  - plage d'humidité relative : 0 à 90 % (sans condensation).
- la durée de conservation d'une pompe turbomoléculaire est de 12 mois à compter de la date d'expédition.
- les pompes turbomoléculaires doivent toujours être démarrées progressivement lorsqu'elles sont reçues et utilisées pour la première fois par le client.
- les pompes turbomoléculaires doivent toujours être démarrées progressivement après une période d'inactivité de 60 jours de la pompe.

### **ATTENTION !**

Si, pour une raison quelconque, la durée de conservation est dépassée, la pompe doit être retournée à l'usine. Contacter le représentant local Agilent Vacuum Sales and Service pour plus d'informations.

---

## Description du produit

Cet équipement est destiné à un usage professionnel et doit être utilisé par des professionnels.

Le TwisTorr 305-IC est une pompe turbomoléculaire pour les applications à vide élevé et ultra-élevé capable de pomper tout type de composé gazeux ou gazeux non corrosif et oxydant.

L'action de pompage est obtenue par une turbine à grande vitesse (max. 60 600 tr/m) entraînée par un moteur électrique à haute performance. La pompe est exempte d'agents contaminants et, par conséquent, adaptée aux applications nécessitant un vide « pur ».

Des informations détaillées sont fournies dans la section « Informations techniques ».

## Installation

### Préparation pour l'installation

Le TwisTorr 305-IC est fourni dans un emballage de protection spécial. Si l'on constate des marques de dommages pouvant s'être produits pendant le transport, contacter aussitôt le bureau de vente local.

Éviter les impacts soudains sur le 305-IC qui seraient causés par la chute. Veiller à entretenir le carton d'emballage afin de le réutiliser en cas de stockage de longue durée ou d'expédition.

Ne pas jeter les matériaux d'emballage sans autorisation. Le matériel est recyclable à 100 % et est conforme à la directive 94/62 de la CEE et aux modifications ultérieures.

#### ATTENTION !

Afin de prévenir les problèmes de dégazage, ne pas utiliser les mains nues pour manipuler les composants qui seront exposés au vide. Toujours porter des gants ou une autre protection adaptée.

---

#### NOTE

L'exposition normale à l'environnement ne peut pas endommager le TwisTorr 305-IC. Néanmoins, il est conseillé de garder le produit scellé dans son sac plastique jusqu'à ce qu'il soit installé dans le système, empêchant ainsi toute forme de pollution par la poussière.

---

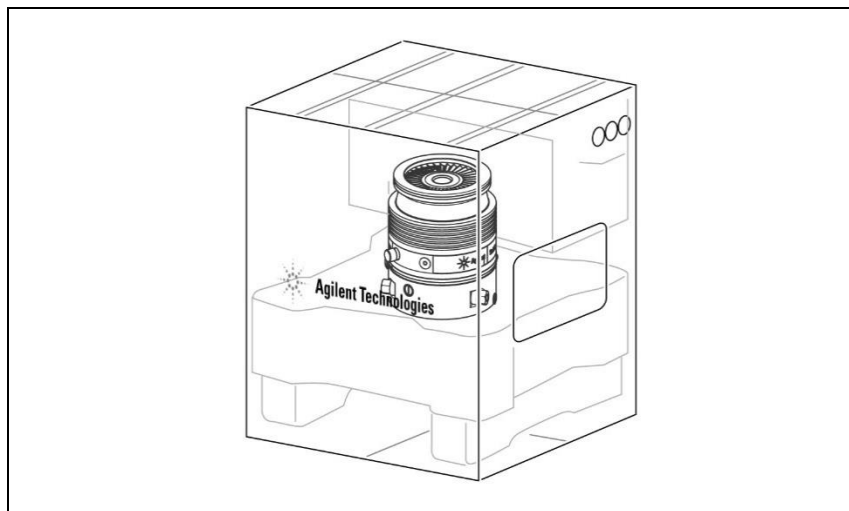

**Figure 1** Emballage du TwisTorr 305-IC

## Configuration

**ATTENTION !** Le 305-IC est un appareil électronique sensible aux décharges électrostatiques, et, à ce point, il est livré dans un sac de protection avec des capuchons sur le raccord USB ainsi que sur le raccord DB15. Retirer ces capuchons de protection uniquement lors du raccordement de la pompe au contrôleur.

**ATTENTION !** Ne pas retirer l'adhésif et le capuchon de protection avant d'être prêt à installer la turbopompe sur le système.

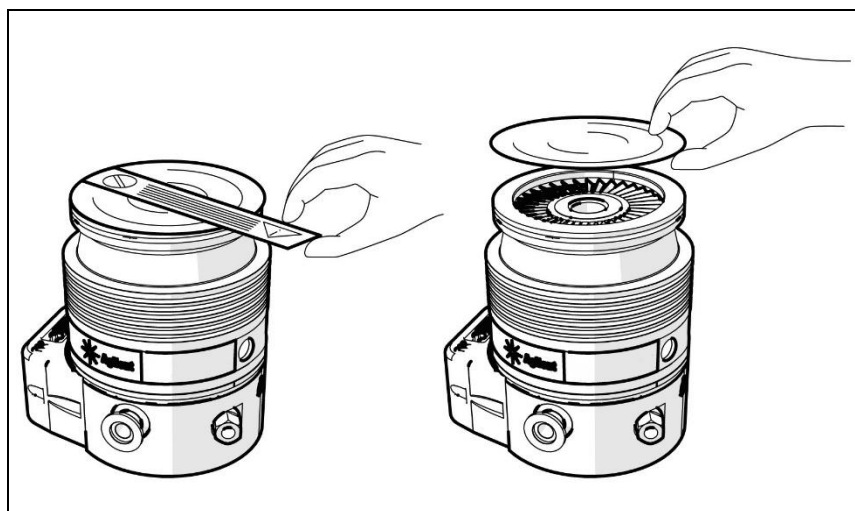

Figure 2

Installer ce dispositif à l'intérieur seulement, et ne pas utiliser la pompe dans un environnement exposé à des agents atmosphériques (pluie, glace, neige), de la poussière, des gaz agressifs, ou dans des environnements explosifs ou présentant un risque élevé d'incendie.

Pendant l'exploitation, les conditions environnementales suivantes doivent être respectées afin d'éviter la condensation :

- pression ambiante maximale : 2 bars au-dessus de la pression atmosphérique
- température : de +5 °C à +35 °C
- humidité relative : 0 à 90 % (sans condensation).

## Montage du TwisTorr 305-IC

---

**AVERTISSEMENT !**



**Le non-respect de ces instructions d'installation peut entraîner le détachement de la pompe du système en cas de défaillance du rotor, ce qui peut causer des dommages matériels, corporels ou la mort.**

---

Le TwisTorr 305-IC peut être installé dans n'importe quelle position. Fixer le TwisTorr 305-IC dans une position stable, en montant la bride d'entrée de la turbopompe sur la contre-bride du système, avec un raccord capable de résister à un couple de 1000 Nm autour de son axe.

La turbopompe avec bride d'entrée ConFlat et ISO K doit être fixée à la chambre à vide au moyen du matériel Agilent approprié.  
Pour plus de détails, voir la section « Installation de la ConFlat et de l'ISO K ».

**ATTENTION !**

Le TwisTorr 305-IC ne peut être fixé au moyen de son support.

---

## Raccordement de la bride à vide élevé

Si le rotor s'arrête soudainement, le couple résultant doit être absorbé par le matériel de fixation de la bride à vide élevé.

Les boulons ou le matériel doivent être conformes aux spécifications ci-dessous.

---

**AVERTISSEMENT !**



Il est obligatoire de raccorder la pompe de manière à résister au couple spécifié dans la section « MODE D'EMPLOI ». Porter une attention particulière à la conception des colliers, au matériau des colliers et des boulons et au couple de fixation des boulons.  
Utiliser uniquement des colliers (ou boulons) de classe haute résistance  $\geq 8.8$ .

---

---

**AVERTISSEMENT !**



Si la pompe est fixée sur une chambre à vide avec des brides différentes de celles recommandées par Agilent, le 305-IC risque de se tordre ou de se déchirer en cas d'arrêt soudain du rotor. La combinaison de différents types de brides n'est pas autorisée. Agilent n'acceptera aucune responsabilité pour tous les dommages résultant d'une mauvaise fixation.

---

### 3 Mode d'emploi

#### Raccordement de la bride à vide élevé

## Installation de la bride ISO-K

Pour les raccords à brides ISO-K, fixer les deux brides avec les attaches modèle IC63250DCMZ ou équivalent, comme indiqué dans la figure suivante (un écran de protection peut être utilisé en option).

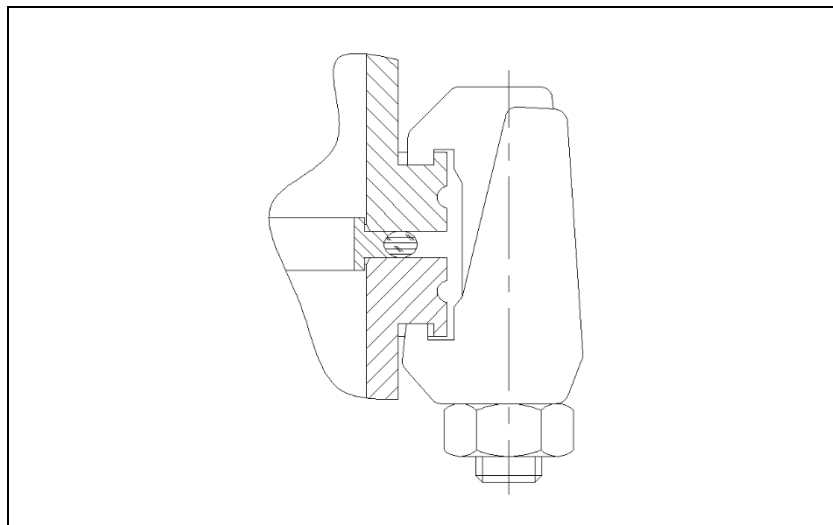

**Figure 3**

Utiliser le nombre requis de brides de serrage :

- 4 pour la bride ISO 100
- 4 pour la bride ISO 160

Serrer les brides de serrage à un couple de 22 Nm.

## Installation de la bride ConFlat

Pour les raccords à bride ConFlat, fixer les deux brides avec les vis comme indiqué dans la figure suivante (un écran de protection peut être utilisé en option).

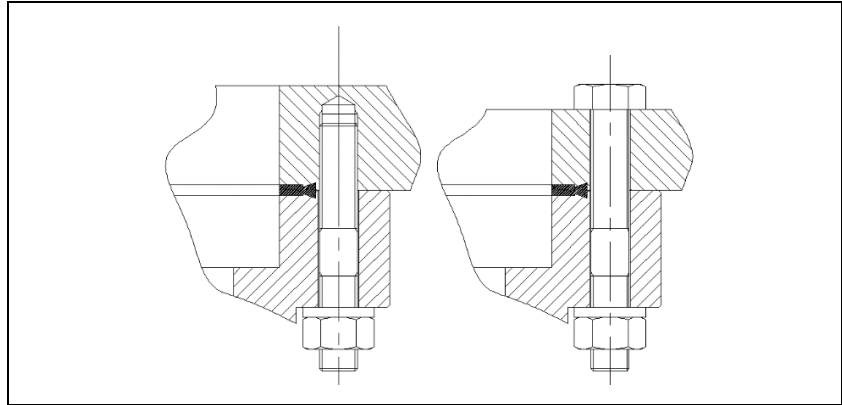

Figure 4

Utiliser le nombre requis de vis :

- 16 pour CFF 6 po
- 20 pour CFF 8 po

Fixer les unités et serrer chaque vis à tour de rôle. Répéter le serrage séquentiel jusqu'à ce que les faces de la bride se rencontrent. Serrer les vis à un couple de 20 Nm.

Pour la bride ConFlat, nous recommandons l'utilisation de boulons en acier à haute résistance uniquement.

Pour faciliter l'assemblage et le démontage, vous avez la possibilité d'appliquer du lubrifiant à haute température Felpro C-100 sur les filetages de vis dépassant de la bride et entre les écrous et la bride.

Dans certains cas, les raccords peuvent être faits seulement avec le boulon dans le côté inférieur.

**ATTENTION !** Faire preuve de prudence lors du serrage des écrous et des boulons pour éviter de créer des bosselures dans l'enveloppe.

### 3 Mode d'emploi

#### Raccordement de la bride à vide préliminaire

## Raccordement de la bride à vide préliminaire

Le raccordement avant doit être effectué à l'aide de la bride KF 16 NW fournie sur le TwisTorr 305-IC. Le raccordement à la pompe de première ligne peut être fait par un tuyau ou conduit de vide. Si un tuyau rigide est utilisé, toute vibration générée par la pompe mécanique doit être amortie par l'utilisation de soufflets.

#### NOTE

Le TwisTorr 305-IC se caractérise également par son taux de compression élevé pour les vapeurs d'huile. Lors de l'utilisation d'une pompe mécanique étanche à l'huile, il est conseillé d'installer un piège approprié entre la turbopompe et la pompe à vide avant afin d'éviter le refoulement de l'huile ou des particules provenant des pompes sèches.

---

## Démarrage et utilisation du TwisTorr 305-IC

Pour allumer le TwisTorr 305-IC via les cartes électroniques embarquées, alimenter la pompe avec la tension d'alimentation appropriée et activer les signaux « START » et « INTERLOCK ». Une fois ces signaux reconnus, le contrôleur démarre la pompe.

### NOTES











- (1) Pour trouver l'emplacement des broches d'entrée de tension d'alimentation (sur le connecteur d'entrée/sortie et d'alimentation), ainsi que les valeurs de tension d'entrée admises, se reporter à la section « Spécifications techniques » et à la section « ENTRÉE/SORTIE et alimentation » du présent mode d'emploi.
  - (2) Pour trouver l'emplacement des broches d'entrée START/STOP et INTERLOCK (sur le connecteur d'entrée/sortie et d'alimentation), ainsi que les valeurs électriques nominales associées, se reporter à la section « ENTRÉE/SORTIE et alimentation » du présent mode d'emploi.
  - (3) Pour savoir comment connecter les signaux START/STOP et INTERLOCK, se reporter à la section « Comment connecter les entrées du collecteur ouvert du contrôleur » du présent mode d'emploi.
  - (4) Le TwisTorr 305-IC est fourni avec un connecteur d'accouplement DB15, non précâblé. Ce connecteur d'accouplement DB15 est adapté pour résister au niveau de courant nécessaire pour alimenter le contrôleur et il est entièrement compatible avec le connecteur DB15 monté sur l'unité de commande. Il peut être utilisé, après câblage approprié, à la fois pour brancher le TwisTorr 305-IC à la source d'alimentation et aux accessoires (ventilateur de refroidissement, valves de purge) mais aussi à la communication en série.
-

### 3 Mode d'emploi

#### Démarrage et utilisation du TwisTorr 305-IC

**AVERTISSEMENT !** L'état de la pompe sera affiché par les 3 LED du contrôleur.



LED	SYMBOLE	STATUT LED	TMARCHE/TARRÊT	SIGNIFICATION
Vert 		Éteint	—	Hors tension
		Allumé, clignotant		305-IC ÉTEINT, statut : ARRÊT/EN ATTENTE D'ENCLENCHEMENT/ÉCHEC
		Allumé, invers clignotant		305-IC ALLUMÉ, vitesse cible pas encore atteinte, statut : DÉMARRAGE (RAMPE)/RÉGLAGE AUTO
		ALLUMÉ, voyant constant		305-IC ALLUMÉ, vitesse cible atteinte, statut : OP. NORMALE
Jaune  		Éteint	—	Aucune alerte
		ALLUMÉ, voyant constant		Avertissement
Rouge  		Éteint	—	Aucun dysfonctionnement
		ALLUMÉ, voyant constant		Dysfonctionnement

**NOTE**

- (1) Si un dysfonctionnement (LED rouge, voyant allumé en continu) est détecté, la pompe ne peut pas tourner à la réception de la commande de démarrage. L'utilisateur peut corriger la cause du dysfonctionnement en vérifiant les messages d'erreur via une communication en série et en se référant également à la liste des actions suggérées. Lorsqu'un dysfonctionnement est détecté, l'appareil électronique entre dans l'état FAIL ; une fois que le motif de la défaillance a été déclenché, les unités doivent recevoir une nouvelle commande de démarrage afin de réinitialiser l'état FAIL. En conséquence, si la cause du dysfonctionnement a été résolue, lors de la réception de la nouvelle commande START, l'état du voyant rouge sera immédiatement désactivé et le 305 IC fonctionnera correctement, indiquant l'état (sur la comm. en série et par les indications LED vertes) qui est adapté à la condition de travail actuelle (RAMP, NORMAL, etc.).
- (2) En cas de détection d'une alerte (LED jaune, voyant allumé en continu), la pompe peut tourner correctement à la réception de la commande de démarrage. L'utilisateur peut dépanner la cause de l'alerte en vérifiant les messages d'erreur via la communication en série et en se référant également à la liste des actions suggérées. Dès la détection d'une condition d'alerte, l'appareil continue de fonctionner sans interruption et montre l'état (sur la comm. en série et par les indications LED vertes) qui est adapté à la condition de travail actuelle (RAMP, NORMAL, etc.).  
En effet, les avertissements ne sont pas liés à des conditions bloquantes pour la fonctionnalité de la pompe. Une fois la cause de l'alerte résolue, la lumière LED jaune sera immédiatement désactivée, et dans la majeure partie des cas, l'utilisateur n'a pas besoin d'exécuter une toute autre action sur le 305 CI. Seulement dans quelques cas, afin de réinitialiser correctement le signal d'avertissement, l'utilisateur doit mettre l'appareil hors tension.

**AVERTISSEMENT !**

**Le démarrage initial de la pompe sera en mode « Démarrage progressif » ; pour plus d'informations sur ce mode, reportez-vous à la section dédiée à la page 102.**

### 3 Mode d'emploi

#### Démarrage et utilisation du TwisTorr 305-IC

## Arrêt du TwisTorr 305-IC

Pour arrêter le 305-IC, non en cas d'urgence, il est nécessaire de faire ceux-ci :

- a) si le 305-IC est configuré en REMOTE MODE et que INTERLOCK est réglé en CONTINUOUS MODE, ouvrir les signaux « START » ou « INTERLOCK » ;
- b) si le 305-IC est configuré en REMOTE MODE et que INTERLOCK est réglé en IMPULSE MODE, ouvrir le signal START ;
- c) si le 305-IC est configuré en mode SERIAL, envoyer une commande STOP au 305-IC.

## Arrêt d'urgence

L'arrêt d'urgence peut être obtenu en retirant l'alimentation électrique.

---

**AVERTISSEMENT !**

**Ce mode ne doit être utilisé qu'en cas d'urgence. L'utilisation de ce mode d'arrêt peut entraîner des défauts et/ou des dommages à la pompe. Une utilisation inappropriée de ce mode d'arrêt pourrait annuler la garantie.**

---

## Entretien

L'entretien n'est pas requis sauf si la LED jaune est allumée. Pour vérifier l'erreur, vous pouvez lire le code via la connexion en série. Si une pompe reste inutilisée pendant une période prolongée, une vérification visuelle de la connexion DB15 est recommandée pour s'assurer qu'elle est exempte d'oxydation.

Tout autre entretien doit être effectué par un personnel autorisé.

---

### AVERTISSEMENT !



**Avant d'effectuer des travaux sur le système, le mettre hors tension, purger la pompe avec la valve de purge, attendre que le rotor soit complètement arrêté et que la température de surface de la pompe soit inférieure à 50 °C.**

---

En cas de défaillance de la pompe, vous pouvez utiliser le service de réparation Agilent ou le « service d'échange avancé Agilent », qui vous fournit un système réusiné pour remplacer le système défaillant. Le 305-IC de rechange est expédié lorsque la commande est passée. Vous retournez ensuite le 305-IC défectueux dans le carton où se trouvait le 305-IC de rechange.

### NOTE

Avant de retourner une pompe pour un service d'échange ou de réparation avancé au fabricant, il est essentiel de remplir et d'envoyer au bureau de vente local le formulaire « Demande de retour » joint au présent mode d'emploi. Une copie doit être insérée dans l'emballage du système avant l'expédition.

---

Si un système doit être mis au rebut, s'assurer que les réglementations locales sont respectées pour une mise au rebut appropriée.

## Durée de vie du rotor

La résistance à la fatigue du rotor de la pompe turbomoléculaire 305-IC résultant de l'évaluation théorique est de 405 000 cycles de montée de l'arrêt à la vitesse maximale et du retour à l'arrêt. Par mesure de précaution, compte tenu de l'utilisation typique de la pompe et des limites de sécurité, Agilent recommande de la remettre en service après 17 ans d'utilisation pour l'entretien.

## Démarrage progressif

---

**AVERTISSEMENT !**



Pour assurer une lubrification adéquate des roulements, la pompe dispose d'un réglage par défaut appelé démarrage progressif. Si la pompe est restée en place pendant une période prolongée ou lors de son démarrage initial, le contrôleur démarre automatiquement en mode démarrage. Ce mode de fonctionnement permet d'accélérer le produit sur une période prolongée.

Ce mode de fonctionnement automatique ne peut pas être désactivé par l'utilisateur. L'utilisateur peut éventuellement décider de démarrer le produit toujours en « mode démarrage progressif », en agissant sur une commande en série adaptée, comme indiqué ci-dessous.

---

Le mode Soft Start (Démarrage progressif) permet la redistribution correcte de la graisse présente dans les roulements, après une longue période d'inactivité.

Le mode Soft Start est automatiquement activé dans les cas suivants :

- 1 Au premier démarrage :
  - 2 Dans les 60 jours suivant l'atteinte du dernier moment à l'état « PLEINE VITESSE ».
- 

**AVERTISSEMENT !**



Ce mode peut être activé manuellement à l'aide de la commande en série WIN100.

Le WIN 100 n'a aucun effet sur le démarrage progressif automatique au premier démarrage et après 60 jours suivant le dernier moment en PLEINE VITESSE.

Voir la section « Protocole Windows ».

---

## Nettoyage

La surface extérieure du 305-IC ne peut être nettoyée qu'avec un détergent doux.

## Mise au rebut

### Signification du logo « WEEE » figurant sur les étiquettes

Le symbole suivant est appliqué conformément à la directive CE WEEE (Déchets d'équipements électriques et électroniques). Ce symbole (**uniquement valide pour les pays de la Communauté européenne**) indique que le produit sur lequel il est appliqué NE doit PAS être mis au rebut avec les ordures ménagères ou les déchets industriels ordinaires, mais passer par un système de collecte sélective. Après avoir vérifié les termes et conditions du contrat de vente, l'utilisateur final est donc prié de contacter le fournisseur du dispositif, maison mère ou revendeur, pour mettre en œuvre le processus de collecte et mise au rebut.



Pour en savoir plus, consulter :

<http://www.agilent.com/environment/product/index.shtml>

### 3 Mode d'emploi

#### Service

## Service

Si, vous, le client avez besoin d'un service d'échange ou de réparation avancé, veuillez contacter le distributeur local ou directement par courrier à :

[vpt-customercare@agilent.com](mailto:vpt-customercare@agilent.com)

[vpl-customercare@agilent.com](mailto:vpl-customercare@agilent.com)

Vous devez remplir le formulaire de demande de retour pour retourner votre pompe à Agilent pour l'entretien (fourni à la fin du présent manuel)

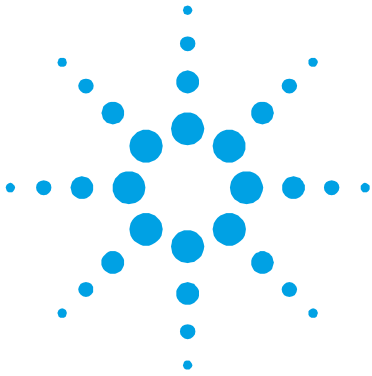

## 4

# Instrucciones de Uso

Acerca del manual	107
Validez	107
Definiciones y terminología	108
Definición de Precaución, Advertencia y Nota	108
Símbolos de advertencia	109
Seguridad	111
Uso correcto	111
Uso incorrecto	112
Equipo de protección	113
Pautas de seguridad para bombas turbomoleculares	115
Transporte y almacenamiento	116
Descripción del producto	117
Instalación	118
Preparación para instalación	118
Puesta en marcha	120
Montaje de la TwisTorr 305-IC	122
Conexión de la brida de alto vaciado	123
Instalación de la brida ISO-K	124
Instalación de la brida ConFlat	125
Conexión de la bomba pre-vaciado	126
Puesta en marcha y funcionamiento de TwisTorr 305-IC	127
Parada de la TwisTorr 305-IC	130
Parada de emergencia	130
Mantenimiento	131
Vida del rotor	131
Arranque suave	132
Limpieza	132
Eliminación	133
Servicio	134

**4 TwisTorr 305-IC Manual de instrucciones**

## Acerca del manual

### Validez

El presente manual contiene las instrucciones para los usuarios de la TwisTorr 305-IC con particular referencia a las nociones relativas a la seguridad, funcionamiento y mantenimiento de primer nivel, limitadas a las operaciones de mantenimiento de las que es responsable el usuario.

Las operaciones de mantenimiento, ilustradas en las secciones correspondientes, con disposiciones específicas relativas al nivel más alto de mantenimiento (personal específicamente entrenado para operaciones de mantenimiento) no deben ser llevadas a cabo por el usuario.

Para una instalación y arranque/parada correctos, consulte el capítulo "Instalación".

Para uso técnico más detallado, consulte el capítulo "Operaciones".

#### NOTA

1. El presente manual contiene información útil para que todo el personal que utilice la TwisTorr 305-IC pueda operarlo de manera segura y garantizar la eficacia perfecta durante toda su vida útil.
  2. Guarde el presente manual, junto con todas las publicaciones relacionadas, en un lugar accesible conocido por todo el personal de mantenimiento/operarios.
-

## Definiciones y terminología

### Definición de Precaución, Advertencia y Nota

Algunas referencias importantes del presente manual están subrayadas y encuadradas en un color de contraste.

---

#### **¡ADVERTENCIA!**



Los mensajes de advertencia atraen la atención del operario a un procedimiento o una práctica específicos que, si no se realizan correctamente, podrían resultar en lesiones personales graves.

---

#### **¡PRECAUCIÓN!**

Los mensajes de precaución se muestran antes de los procedimientos que, si no se observasen, podrían causar daños graves al equipo.

---

#### **NOTA**

Las notas tienen el fin de atraer la atención a la información importante y proporcionar más detalles acerca de pasos específicos.

---

## Símbolos de advertencia

La siguiente lista contiene símbolos que aparecen en conjunción con las advertencias de la TwisTorr 305-IC. El peligro que describen también se muestra.

Un símbolo triangular indica una advertencia. Los significados de los símbolos que pueden aparecer junto a las advertencias en la documentación o el instrumento mismo son los siguientes:



Corriente directa



No tocar



Declaración Europea  
de Conformidad



Peligro genérico



Lugar de fabricación



APAGADO



ENCENDIDO



Terminal protectora  
de tierra

## 4 Instrucciones de Uso

### Símbolos de advertencia

El siguiente símbolo podría utilizarle en las etiquetas de advertencia fijadas al instrumento. Cuando vea este símbolo, consulte la operación relevante o el manual de servicio para el procedimiento referido por dicha etiqueta de advertencia.



Los siguientes símbolos aparecen en el instrumento para su información.

	Red eléctrica encendida
	Si está roja, indica fallo
	Si está amarilla, indica advertencia
	puerto USB
	Terminal protectora de tierra
	No tocar
J1	Conector principal
NFC	Near Field Communication (antena de smartphone)
CE	Certificación CE
	Certificación CSA
RoHS	Certificación de Restricción de Sustancias Peligrosas
	Certificación China RoHS
	Equipo de Desecho Eléctrico y Electrónico

## Seguridad

La presente sección contiene la información, prescrita por la Directiva de Maquinario 2006/42/EC, que es esencial para el cumplimiento y seguimiento de las normativas de seguridad, tanto generales como en relación con el uso específico de la máquina.

El incumplimiento de las presentes instrucciones y las otras instrucciones en el presente manual pueden hacer que las condiciones de seguridad previstas en la fase de diseño sean ineficaces y causen accidentes a los que operen la maquinaria.

Agilent Technologies niega cualquier responsabilidad por daños a la máquina o la seguridad física del operario o terceras partes derivados del incumplimiento de las reglas de seguridad indicadas en la documentación técnica.

## Uso correcto

El presente manual contiene advertencias importantes e instrucciones de seguridad a cumplir para que la unidad funcione de manera segura.

El producto descrito en el presente manual está destinado exclusivamente al área de aplicación especificado en las instrucciones. El manual también proporciona indicaciones acerca de los requisitos esenciales para la aplicación y funcionamiento del producto, así como las medidas de seguridad que pueden ser adoptadas para garantizar el funcionamiento regular. Agilent Technologies no proporciona ninguna garantía ni asume ninguna responsabilidad por aplicaciones que no sean las descritas en el presente manual, o en las que no se respeten los requisitos y medidas de seguridad esenciales.

El producto solo puede ser utilizado por personal cualificado que pueda tomar las medidas de seguridad necesarias bajo condiciones que no causen daños o lesiones. Cualquier accesorio y equipo utilizado con el producto debe ser proporcionado o aprobado por Agilent Technologies.

Cualquier ajuste u operación de mantenimiento debe ser realizada por un técnico profesional informado sobre los riesgos.

Las reparaciones del producto deberán ser realizadas exclusivamente por personal autorizado por Agilent.

## Uso incorrecto

Agilent Technologies niega cualquier responsabilidad derivada del uso incorrecto de la TwisTorr 305-IC.

El uso incorrecto anulará todas las reclamaciones por responsabilidad y garantías.

El uso incorrecto se define como:

- instalación de la bomba con el material de montaje incorrecto
- bombear gases corrosivos y oxidantes sin el flujo de purga adecuado (véase sección "Pump used with corrosive and oxidizing gases")
- bombear gases explosivos
- bombear vapores condensantes
- bombear líquidos
- bombear polvo
- funcionamiento con capacidad de gas alta incorrecta
- funcionamiento con presiones de pre-vaciado altas incorrectas
- Funcionamiento con modalidad de gas seleccionada diferente del gas utilizado
- funcionamiento con niveles altos incorrectos de entrada de calor aislada
- funcionamiento en campos magnéticos altos incorrectos
- descargar con velocidad de descarga alta incorrecta
- uso de la bomba de vacío para generar presión
- funcionamiento del dispositivo en zonas con radiación ionizante
- funcionamiento en zonas potencialmente explosivas
- uso del dispositivo en sistemas en los que la fuerza de impacto y las vibraciones o fuerzas periódicas afecten al dispositivo.

## Equipo de protección

El equipo de protección de los operarios que están operando o ejecutando el mantenimiento del sistema de bombeado debe ser siempre adecuado para el tipo de operación que se está ejecutando. Asimismo, debe cumplir los requisitos de seguridad de la legislación vigente en el país donde se utilice la máquina.

En general, el operario debe llevar calzado de prevención de accidentes mientras maneje la 305-IC y durante la instalación.



### ¡ADVERTENCIA!

#### **Peligro a la salud por presencia de sustancias peligrosas durante el mantenimiento o instalación**

Dependiendo de la peculiaridad del proceso, las bombas de vaciado, los componentes o líquidos operativos pueden estar contaminados por sustancias tóxicas, reactivas o radioactivas.

→ Lleve equipo de protección adecuado durante el mantenimiento y las reparaciones o en caso de reinstalación.



### ¡ADVERTENCIA!

#### **Riesgo de lesión por caída de objetos**

Cuando transporte bombas de vaciado a mano, hay peligro de que las cargas se resbalen y se caigan.

→ Lleve las bombas de vaciado pequeñas y medianas con las dos manos.

→ Cualquier equipo de peso mayor a 20 kg deberá ser transportado utilizando un dispositivo de elevación.

→ Lleve calzado de seguridad con punta de acero según la directiva EN 347.



## 4 Instrucciones de Uso

### Equipo de protección



---

#### **¡PRECAUCIÓN!**

#### **Riesgo de lesión por bordes afilados**

Los discos del rotor y estátor de las turbobombas tienen bordes muy afilados.

- ➔ Antes de realizar mantenimiento en la bomba o antes de cualquier acción de montaje/desmontaje de la bomba del sistema, espere a que la bomba se detenga completamente.
  - ➔ No opere directamente dentro de la brida de alto vaciado.
  - ➔ Si es necesario lleve guantes de protección según EN 420.
-

## Pautas de seguridad para bombas turbomoleculares

Las bombas turbomoleculares, como se describen en el siguiente manual de funcionamiento, contienen una gran cantidad de energía cinética debido a la alta velocidad de rotación en combinación con la masa específica de sus rotores.

En caso de avería de una parte mecánica de la bomba, la energía de rotación podría pasarse a lo que esté fijada la bomba.

---

### **¡ADVERTENCIA!**



**Para evitar daños al equipo y evitar lesiones al personal operativo se deben seguir estrictamente las instrucciones indicadas en el presente manual.**

---

## Transporte y almacenamiento

Para garantizar el máximo nivel de rendimiento y fiabilidad de las bombas turbomoleculares de Agilent, las siguientes pautas deben seguirse para evitar la condensación:

- cuando se envíen, mueven o almacenen las bombas, no deberán excederse las siguientes especificaciones ambientales:
  - rango de temperatura: -40 °C a 70 °C
  - rango de humedad relativo: 0 a 90 % (no condensante).
- la vida útil de una bomba turbomolecular es de 12 meses desde la fecha de envío.
- las bombas turbomoleculares deben iniciarse con arranque suave cuando se reciben y puestas en marcha por primera vez por el cliente.
- las bombas turbomoleculares deben iniciarse con arranque suave siempre después de un período de 60 días de inactividad de la bomba.

### **¡PRECAUCIÓN!**

Si, por cualquier motivo, la vida útil es excedida, la bomba deberá ser devuelta a la fábrica. Por favor, contacte con el representante local de Ventas y Servicios de Vacío de Agilent para más información.

---

## Descripción del producto

Este equipo está destinado a uso profesional y deberá ser utilizado por profesionales.

La TwisTorr 305-IC es una bomba turbomolecular para aplicaciones de vacío ultra alto que puede bombear cualquier tipo de gas o compuesto de gas no corrosivo y oxidante.

La acción de bombeado se obtiene a través de una turbina de alta velocidad (max. 60600 rpm) impulsada por un motor eléctrico de alto rendimiento. Está libre de agentes contaminantes y, por tanto, es adecuada para aplicaciones que requieran un vacío "limpio".

Puede encontrar información detallada en la sección "Technical Information".

## Instalación

### Preparación para instalación

La TwisTorr 305-IC se proporciona con un embalaje protector especial. Si esta muestra signos de daños que puedan haber ocurrido durante el transporte, contacte con su oficina de ventas local.

Evite impactos repentinos a la 305-IC que podrían ser causados al dejarla caer. Tenga cuidado de guardar la caja de embalaje para reutilizarla en caso de almacenamiento durante largos períodos de tiempo o en caso de envío.

No tire los materiales de embalaje de manera no autorizada. El material es 100% reciclable y cumple con la Directiva EEC 94/62 y modificaciones posteriores.

**¡PRECAUCIÓN!** Para evitar problemas de liberación de gases, no utilice las manos para manejar los componentes que estén expuestos a la bomba. Utilice guantes u otra protección adecuada siempre.

---

#### NOTA

La exposición normal al ambiente no puede dañar la TwiTorr 305-IC. Sin embargo, es aconsejable mantenerla sellada en su bolsa de plástico hasta que esté instalada en el sistema, evitando así cualquier forma de contaminación por polvo.

---

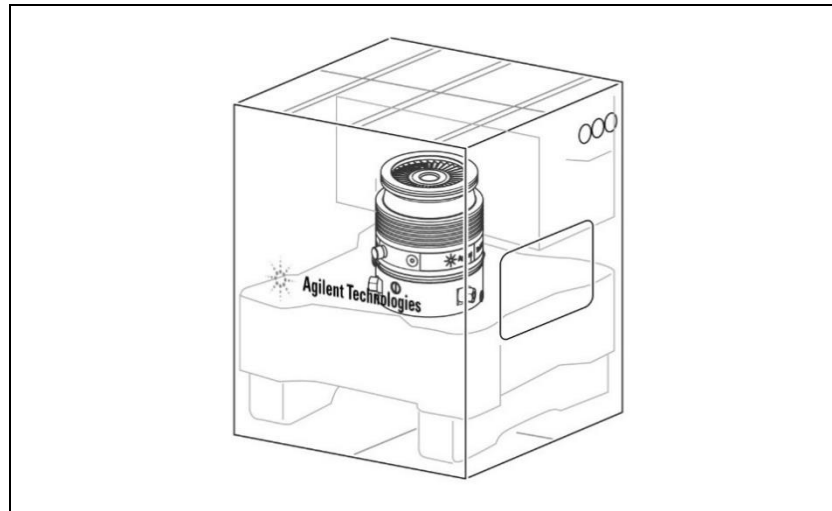

**Figura 1** Embalaje de la TwisTorr 305-IC

## Puesta en marcha

**¡PRECAUCIÓN!** La 305-IC es un dispositivo electrónico sensible a las descargas electrostáticas y, por este motivo, está equipada con bolsas protectoras con tapas en la conexión USB y en la conexión DB15. Extraiga estas tapas protectoras solo cuando conecte la bomba al controlador.

**¡PRECAUCIÓN!** No extraiga la tapa adhesiva y protectora hasta que esté preparado para instalar la turbobomba en el sistema.



Figura 2

Instale este dispositivo solo en interiores y no utilice la bomba en un ambiente expuesto a agentes atmosféricos (lluvia, hielo, nieve), polvo, gases agresivos o en ambientes explosivos o con un alto riesgo de incendio.

Durante el funcionamiento, las siguientes condiciones ambientales deben cumplirse para evitar la condensación:

- presión ambiente máxima: 2 bar por encima de presión atmosférica
- temperatura: de +5 °C a +35 °C
- humedad relativa: 0 – 90 % (no condensante).

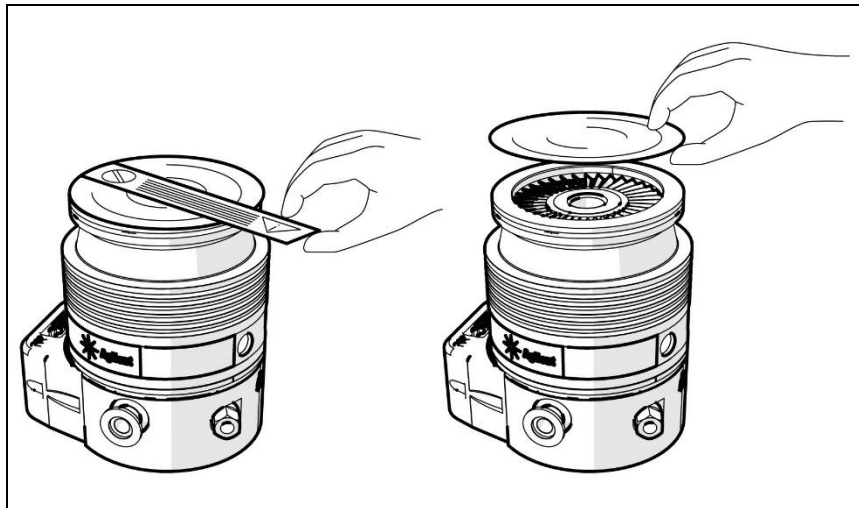
## Montaje de la TwisTorr 305-IC

---

**¡ADVERTENCIA!**



El incumplimiento de las presentes instrucciones podría causar que la bomba se despegue del sistema en el caso de un fallo del rotor, lo que podría causar daños a la propiedad o lesiones graves o la muerte.

---

La TwisTorr 305-IC puede ser instalada en cualquier posición. Fije la TwisTorr 305-IC en una posición estable, montando la brida de entrada de la turbobomba en el sistema de la contrabrida, con una conexión capaz de soportar una torsión de 1000 Nm alrededor de su eje.

La turbobomba con brida de entrada ConFlat e ISO K debe estar fijada a la cámara de vacío mediante las herramientas adecuadas de Agilent. Para más detalles consulte la sección “Installation of ConFlat and ISO K”.

**¡PRECAUCIÓN!**

La TwisTorr 305-IC no puede ser fijada en su base.

---

## Conexión de la brida de alto vaciado

Si el rotor se detiene de repente, la torsión resultante debe ser absorbida por las herramientas que fijan la brida de vacío alto.

Los tornillos y herramientas deben cumplir la siguiente especificación.

---

**¡ADVERTENCIA!**



Es obligatorio conectar la bomba de manera que pueda soportar la torsión especificada en la sección "INSTRUCCIONES DE USO". Preste especial atención al diseño de la pinza, los materiales de las pinzas y tornillos y la torsión de fijación del tornillo.

Utilice solo pinzas (o tornillos) de clase de resistencia alta  $\geq 8.8$ .

---

**¡ADVERTENCIA!**



Si la bomba está fijada a una cámara de vacío con bridas diferentes a las recomendadas por Agilent, es posible que la 305-IC se tuerza o se rompa si el rotor se detiene de repente. La combinación de diferentes tipos de bridas no está permitida. Agilent no aceptará ninguna responsabilidad por daños resultantes de una sujeción incorrecta.

---

## Instalación de la brida ISO-K

Para las conexiones de brida ISO-K, sujete las dos bridas con el modelo de pinzas IC63250DCMZ o equivalente, como se muestra en la figura siguiente (se puede utilizar una pantalla de protección opcionalmente).

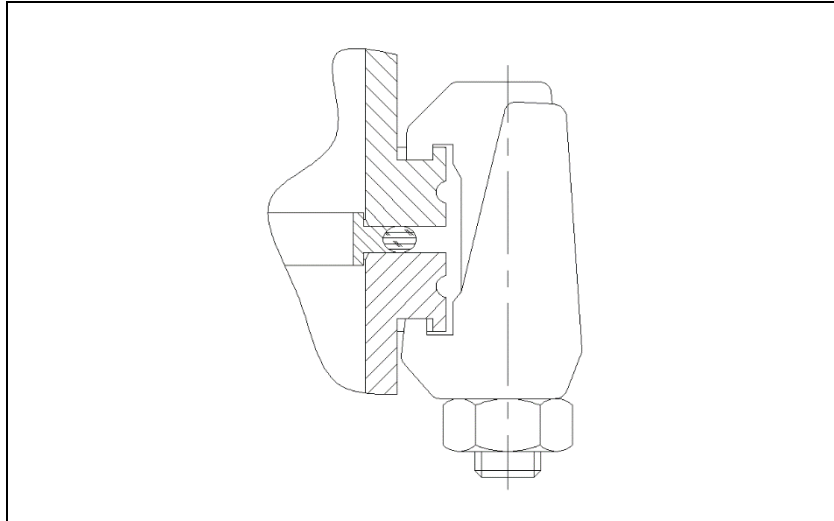

**Figura 3**

Utilice el número de pinzas de garra requerido:

- 4 para brida ISO 100
- 4 para brida ISO 160

Apriete las pinzas de garra con una torsión de 22 Nm.

## Instalación de la brida ConFlat

Para las conexiones de brida ISO-K, sujete las dos bridas con los tornillos como se muestra en la figura siguiente (se puede utilizar una pantalla de protección opcionalmente).

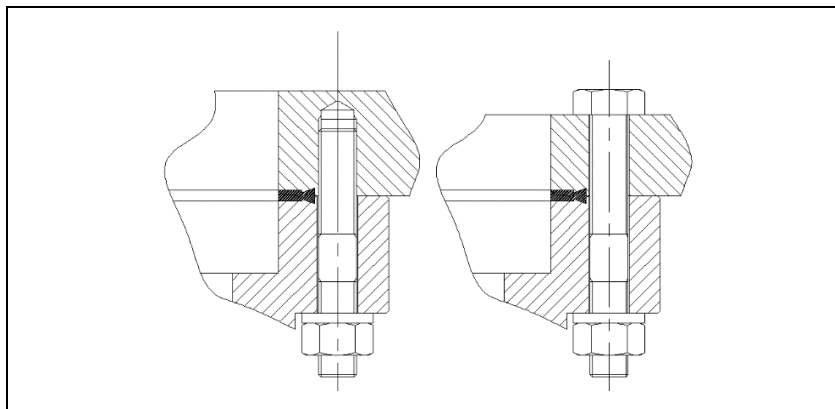

**Figura 4**

Utilice el número de tornillos requerido:

- 16 para CFF 6"
- 20 para CFF 8"

Fije las unidades y apriete cada tornillo a su vez. Vuelva a apretar en secuencia hasta que las caras de la brida se encuentren. Apriete los tornillos con una torsión de 20 Nm.

Para la brida ConFlat le recomendamos que use solo tornillos de acero de alta resistencia.

Para facilitar el montaje y desmontaje es opcional aplicar lubricante de alta temperatura.

Felpro C-100 a las roscas de los tornillos que sobresalgan de la brida y entre las roscas y la brida.

En algunos casos, las conexiones solo pueden hacerse con el tornillo en la cara inferior.

**¡PRECAUCIÓN!**

Tenga cuidado cuando apriete las tuercas y tornillos para evitar abollar la envoltura.

## 4 Instrucciones de Uso

### Conexión de la bomba pre-vaciado

# Conexión de la bomba pre-vaciado

La conexión de prevacío debe hacerse utilizando la brida KF 16 NW proporcionada en la TwisTorr 305-IC. La conexión a la bomba prevacío puede hacerse mediante una manguera o tubo apropiada para vacío. Si se utiliza un tubo rígido, cualquier vibración generada por la bomba mecánica debe ser amortiguada a través del uso de fuelles.

#### NOTA

La TwisTorr 305-IC está caracterizada por su tasa de compresión alta y por sus vapores de aceite. Cuando utilice una bomba mecánica sellada con aceite, es aconsejable instalar un colector adecuado entre la turbobomba y la bomba de prevacío para evitar que se salga el aceite o el particulado de las bombas secas.

---

## Puesta en marcha y funcionamiento de TwisTorr 305-IC

Para encender la TwisTorr 305-IC a través de los controladores abordo, proporcione la bomba con la tensión de alimentación y la acción en las señales "START" e "INTERLOCK". Una vez estas señales sean reconocidas el controlador iniciará la bomba.

### NOTAS















- (1) Para encontrar la ubicación de las clavijas de entrada de tensión de alimentación (en el Conector IN/OUT y Suministro Eléctrico), así como los valores de tensión de entrada, consulte la sección "Technical Specifications" y "IN/OUT and Power Supply" del presente manual de instrucciones.
  - (2) Para encontrar la ubicación de las clavijas de entrada de START/STOP e INTERLOCK (en el Conector IN/OUT y Suministro Eléctrico), así como los valores eléctricos nominales, consulte la sección "IN/OUT and Power Supply" del presente manual de instrucciones.
  - (3) Para más detalles sobre cómo conectar las señales START/STOP e INTERLOCK, consulte la sección "How to Connect the Open Collector Inputs of the Controller" del presente manual de instrucciones.
  - (4) La TwisTorr 305-IC dispone de un conector ficha DB15 pre-cableado. Este conector ficha DB15 es adecuado para soportar el nivel de corriente necesario para abastecer el controlador y es totalmente compatible con el conector DB15 que está montado en la unidad de control. Puede ser utilizado, después de cablearse adecuadamente, tanto para conectar la TwisTorr 305-IC a la fuente de alimentación y a las partes de los accesorios (ventilador, válvulas de descarga) y el puerto serial comm.
-

## 4 Instrucciones de Uso

### Puesta en marcha y funcionamiento de TwisTorr 305-IC

**¡ADVERTENCIA!** El estado de la bomba será mostrado por las 3 LEDs en el controlador.



LED	SÍMBOLO	ESTADO LED	TON/TOFF	SIGNIFICADO
Verde 		Apagado		Apagado
		Encendido, parpadeando		305-IC OFF, estado: STOP/WAITING INTERLOCK/FAIL
		Encendido, inverso parpadeando		305-IC ON, velocidad meta no alcanzada, estado: STARTING (RAMP)/AUTO TUNING
		ON, luz continua		305-IC ON, velocidad meta alcanzada, estado: NORMAL OP.
		Encendido, parpadeando		305-IC ON, reducción velocidad, estado: BRAKING
Amarillo 		Apagado		No advertencia
		ON, luz continua		Advertencia
Rojo 		Apagado		No avería
		ON, luz continua		Avería

**NOTA**

- (1) En caso de detectarse avería (LED roja, azul continuo ON), la bomba no puede girar cuando recibe el comando de inicio. El usuario puede resolver problemas por motivo de la avería al comprobar los mensajes de error mediante la comunicación de serie y consultando la lista de acciones sugeridas. Mientras se detecta una avería, la unidad electrónica entra en estado FAIL; cuando la razón de la avería haya sido resuelta, las unidades deben recibir un nuevo comando de inicio para reiniciar el estado FAIL. Consecuentemente, si la razón de la avería se ha solucionado, al recibir el nuevo comando START, el estado de luz led roja se apagará inmediatamente y la 305-IC funcionará correctamente, mostrando el estado (en el puerto comm serial y mediante los indicadores de led verde) que es adecuado para la condición de trabajo actual (RAMP, NORMAL, etc.).
- (2) En caso de detectarse advertencia (LED amarilla, luz continua ON), la bomba no puede girar correctamente cuando recibe el comando de inicio. El usuario puede resolver problemas por motivo de la advertencia al comprobar los mensajes de error mediante la comunicación de serie y consultando la lista de acciones sugeridas. Si se detecta una condición de advertencia, la unidad sigue funcionando sin interrupciones y mostrando el estado (en el comm. serial y con las indicaciones de luz verde) que es adecuado a la condición de trabajo actual (RAMP, NORMAL, etc..).  
Esto se debe a que las advertencias no están relacionadas con cualquier condición de bloqueo para la funcionalidad de la bomba. Cuando la razón de la advertencia haya sido resuelta, la luz led amarilla se apagará inmediatamente, y en la mayoría de los casos, el usuario no necesita realizar ninguna otra acción en la 305 I-C. Solo en muy pocos casos, para poder reiniciar la señal de advertencia, el usuario tiene que apagar la unidad.

**¡ADVERTENCIA!**

**El arranque inicial de la bomba estará en modo "Arranque suave"; para más información sobre este modo, consulte la sección dedicada en la página 132.**

## Parada de la TwisTorr 305-IC

Para detener la 305-IC cuando no hay una emergencia, es necesario:

- a) si la 305-IC está configurada en REMOTE MODE, y el INTERLOCK está en CONTINUOUS MODE, abra las señales "START" o "INTERLOCK";
- b) si la 305-IC está configurada en REMOTE MODE, y el INTERLOCK está en IMPULSE MODE, abra las señales "START";
- c) si la 305-IC está configurada en modo SERIAL, envíe un comando STOP a la 305-IC.

## Parada de emergencia

La parada de emergencia puede conseguirse extrayendo la fuente de alimentación.

---

**¡ADVERTENCIA!**



**Este modo debe ser utilizada solo en caso de emergencia. El uso de este modo de parada podría llevar a fallos y/o daños en la bomba. El uso indebido de este modo de parada podría anular la garantía.**

---

## Mantenimiento

El mantenimiento no es necesario si la LED amarilla no está encendido. Para comprobar el error puede leer el código mediante la conexión de serie. Si la bomba está parada durante una cantidad de tiempo prolongada, se recomienda una inspección visual de la conexión DB15 para asegurarse de que está libre de oxidación. Cualquier otro mantenimiento debe realizarse por personal autorizado.

### ¡ADVERTENCIA!



**Antes de realizar cualquier trabajo en el sistema, desconecte de la fuente de alimentación, descargue la bomba con la válvula de descarga, espere hasta que el rotor esté completamente detenido y espere hasta que la temperatura de la superficie de la bomba esté por debajo de 50°C.**

Si la bomba falla, puede utilizar el servicio de reparación de Agilent o el "servicio de intercambio avanzado de Agilent", que le proporcionará un sistema refabricado para sustituir el sistema averiado. El cambio de 305-IC será enviado cuando se realice el pedido. Entonces tendrá que devolver la 305-IC averiada en la caja en la que venga la 305-IC nueva.

### NOTA

Antes de devolver la bomba para ser reparada o para el servicio de intercambio avanzado al fabricante, es esencial completar y enviar el formulario "Solicitud de Cambio" adjunto al presente manual de instrucciones a la oficina de ventas local. Se deberá insertar una copia del mismo en el paquete del sistema antes de enviarlo.

Si un sistema debe ser descartado, asegúrese de que se cumplen las normativas locales para la eliminación adecuada.

## Vida del rotor

La resistencia a la fatiga del rotor de bomba turbomolecular 305-IC resultante de la evaluación teórica de 405000 ciclos de aceleración desde parada y parada de nuevo.

Como medida de precaución, considerando el uso típico de la bomba y teniendo en cuenta los límites de seguridad, Agilent recomienda devolver la bomba después de 17 años de uso para mantenimiento.

# Arranque suave

---

#### ¡ADVERTENCIA!



Para asegurar la lubricación adecuada de los cojinetes la bomba tiene una configuración por defecto llamada arranque suave. Si la bomba ha estado parada durante un período de tiempo largo o en su arranque inicial el controlador iniciará automáticamente el arranque suave. Este modo de funcionamiento lleva el producto a acelerar durante un período de tiempo prolongado. Este modo de funcionamiento automático no puede ser desactivado por el usuario. El usuario puede decidir arrancar el producto siempre en "soft start mode", actuando en un comando serial adecuado, como se especifica a continuación.

---

El modo "Soft Start" permite la correcta redistribución de la grasa presente en los cojinetes, después de un período de inactividad prolongado.

El modo "Soft Start" se activa automáticamente en los siguientes casos:

- 1 En el primer arranque:
  - 2 Después de 60 días de haber alcanzado el último momento en la condición "FULL SPEED".
- 

#### ¡ADVERTENCIA!



Este modo puede ser activado manualmente utilizando el comando serial WIN100.

El WIN 100 no tiene ningún efecto en el arranque suave automático en el primer arranque y después de 60 días desde el último momento en FULL SPEED.

Consulte la sección "Windows Protocol".

---

## Limpieza

La superficie exterior de la 305-IC puede ser limpiada con detergente suave solamente.

## Eliminación

### Significado del logotipo "WEEE" encontrado en las etiquetas

El siguiente símbolo se aplica de acuerdo con la Directiva CE WEE (Equipo de Desecho Eléctrico y Electrónico). Este símbolo (**válido solo en países de la Comunidad Europea**) indica que el producto al que se aplica NO debe eliminar junto con desechos domésticos o industriales normales, sino que debe ser enviado a un sistema de recolección de desechos diferenciada. El usuario final deberá contactar con el proveedor del dispositivo, ya sea la Empresa matriz o un minorista, para iniciar el proceso de recolección y eliminación después de comprobar los términos contractuales y las condiciones de venta.



Para más información consulte:

<http://www.agilent.com/environment/product/index.shtml>

## Servicio

Si un cliente necesita un servicio de intercambio avanzado o reparación, contacte con un distribuidor local o contacte por correo a:

[vpt-customercare@agilent.com](mailto:vpt-customercare@agilent.com)

[vpl-customercare@agilent.com](mailto:vpl-customercare@agilent.com)

Es obligatorio completar la Solicitud de Devolución para devolver su bomba a Agilent para mantenimiento (proporcionada al final del presente manual).

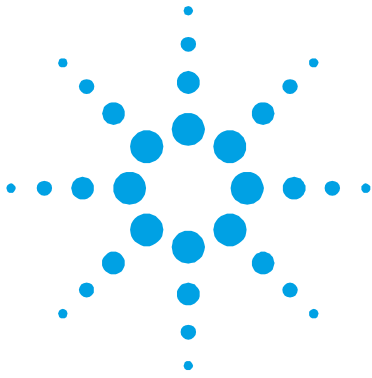

## 5 使用说明

关于这本手册	137
有效性	137
定义和术语	138
警告、警告和注释的定义	138
警告符号	139
安全	141
正确使用	141
使用不当	142
防护设备	143
涡轮分子泵安全指南	145
运输及存储	146
产品描述	147
安装	148
安装准备	148
设置	150
<b>TwisTor 305-IC 的安装</b>	152
高真空法兰的连接	153
ISO-K 法兰的安装	154
ConFlat 法兰的安装	155
前真空泵的连接	156
<b>TwisTorr 305-IC 的启动和运行</b>	157
停止 TwisTorr 305-IC	160
紧急停止	160
维护	161
转子寿命	161
慢启动	162
清洗	162
处置方式	163
服务	164



## 关于这本手册

### 有效性

本手册列出了**TwisTorr 305-IC**的用户使用说明，尤其是有关安全、操作和一级维护的概念，仅限于用户负责的维护操作。

一些特定章节包含与更高级别的维护（经过专门培训的维护操作人员才能操作）有关的特定规定，用户不得执行此类维护操作。

有关正确的安装和启动/停止，请参阅"安装"章节。

有关更详细的技术使用，请参阅"操作"章节。

#### 注意

1. 本手册包含实用的信息，以确保所有使用 **TwisTorr 305-IC** 的人员都能安全地操作它，并确保其使用寿命达到最高效率。
  2. 将本手册以及所有相关出版物保存在所有操作员/维修人员都知道的无障碍位置。
-

## 定义和术语

### 警告、警告和注释的定义

本手册的一些重要参考资料会以对比色突出显示和框出。

---

#### 警告！



警告消息让操作员特别注意特定的程序或操作，如果执行不当，可能导致严重的人身伤害。

---

#### 小心！

小心消息会在操作过程之前显示，如果未注意到，可能会损坏设备。

---

#### 注意

注意旨在提醒人们注意重要信息，并提供有关具体步骤的更多详细信息。

---

## 警告符号

以下是在TwisTorr 305-IC上与警告一起显示的符号列表。还显示了这些符号所指的危险。

三角形符号表示警告。在文档或仪器警告旁边可能出现的符号含义如下：



直流



请勿触摸



欧洲符合性声明



一般危险



生产现场



电源关闭



电源开启



保护接地端子

## 5 使用说明

### 警告符号

以下符号可用作附在仪器上的警告标签。当您看到此符号时，请参阅相关操作或维修手册，了解该警告标签所指的正确操作过程。



以下符号会出现在仪器上供您参考。

	电源开启
	如果为红色，则表示故障
	如果为黄色，则表示警告
	USB 端口
	保护接地端子
	请勿触摸
J1	主连接器
Nfc	近场通信（智能手机天线）
CE	CE 认证
	CSA 认证
RoHS	有害物质认证限制
	RoHS 中国认证
	废弃电气和电子设备

## 安全

本节包含机械指令 2006/42/EC 所规定的信息，这些信息对于遵守和遵守安全法规以及机器的具体使用至关重要。

如不遵守本手册中包含的这些说明和其他说明，可能会导致设计阶段设想的安全条件效率低下，并导致操作机器的人员发生事故。

对于由于未遵守技术文档中指示的安全规则而造成的机器损坏或操作人员或第三方的人身安全意外，安捷伦科技公司 (Agilent Technologies) 不承担全部责任。

## 正确使用

本手册包含重要的警告和安全说明，以确保设备安全工作。

本手册中描述的产品仅针对说明中指定的应用领域。本手册还提供了有关产品应用和操作基本要求的指示，以及为保证正常运行可采取的安全措施。对本手册中未描述的应用或未遵守基本要求和安全措施的应用，安捷伦科技公司 (Agilent Technologies) 不提供任何保证或承担任何责任。本产品只能由能够在不造成损坏或伤害的条件下采取必要安全措施的合格人员使用。与产品一起使用的任何附件和设备必须由安捷伦科技公司 (Agilent Technologies) 提供或批准。

任何调整或维护操作必须由了解风险的专业技术人员执行。

产品的维修只能由安捷伦授权的人员执行。

## 使用不当

对于因不正确使用TwisTorr 305-IC而造成的任何后果，安捷伦科技公司 (Agilent Technologies)不承担任何责任。

使用不当将导致所有责任保证和索赔保证失效。使用不当的定义为：

- 使用未指定的安装材料安装泵
- 在没有适当吹扫流量的情况下泵送腐蚀性和氧化性气体（参见"泵与腐蚀性和氧化性气体一起使用"的章节）
- 泵送爆炸气体
- 泵送冷凝蒸汽
- 泵送液体
- 泵送粉尘
- 气体产量过高的情况下作业
- 前真空压力过高的情况下作业
- 使用与实际使用的气体不同的选定气体方式进行操作
- 绝缘热输入水平过高的情况下作业
- 磁场过高的情况下作业
- 使用过高的通风速率进行通风
- 使用真空泵来产生压力
- 在电离辐射区域运行设备
- 在潜在爆炸区作业
- 在冲击应力、振动或周期性力会影响设备的系统中使用设备。

## 防护设备

进行或执行泵送系统维护的 operators 必须始终使用适合操作类型的防护设备。此外，它必须符合使用机器所在国家的现行立法安全要求。

通常，操作员在操作 305-IC 时和安装过程中必须穿防事故鞋。



### 警告!

#### 在维护或安装过程中有害物质对健康的危害

根据工艺特点，真空泵、部件或工作流体可能有有毒、反应性或放射性物质污染。



→ 在维护和修理期间或重新安装时，请佩戴合适的防护设备。



### 警告!

#### 掉落物体造成人身伤害的风险

手动运输真空泵时，存在负载滑倒和坠落的危险。



→ 双手携带中小型真空泵。  
→ 任何重量超过 20 公斤的设备都应使用合适的起重装置进行搬运。

→ 根据指令 EN 347，请穿带钢脚趾盖的安全鞋。

## 5 使用说明

### 防护设备



#### 小心！

#### 锋利边缘有划伤的风险

涡轮泵的转子和定子盘具有非常锋利的边缘。

- 在维修泵之前，或在泵从系统中执行任何安装/拆卸操作之前，等待泵完全停止。
- 请勿直接在高真空法兰内操作。
- 如有必要，请按照 EN 420 佩戴防护手套。

## 涡轮分子泵安全指南

以下操作手册中描述的涡轮分子泵包含大量动能，因为旋转速度高，加上转子拥有特定质量。

在泵的机械部件发生故障的情况下，旋转能量可能会释放到泵所固定的任何位置。

**警告！**



为避免损坏设备并防止操作人员受伤，应严格遵守本手册中提供的安装说明！

## 运输及存储

为了保证安捷伦涡轮分子泵的最高性能和可靠性，必须遵循以下准则以避免出现冷凝的情况：

- 运输、移动和存储泵时，不应超出以下环境条件：
  - 温度范围：-40 °C 至 70 °C
  - 相对湿度范围：0至90%（非冷凝状态）。
- 涡轮分子泵的保质期从发货日期起为12个月。
- 涡轮分子泵在首次由客户接收和操作时必须进行慢启动。
- 涡轮分子泵必须在泵处于非活动状态的 **60**天月后进行慢启动。

### 小心！

如果由于任何原因超过保质期，必须将泵退回工厂。请联系当地的安捷伦真空销售和服务代表以了解相关信息。

---

## 产品描述

本设备用于专业用途，供专业人员使用。

**TwisTorr 305-IC** 是一款涡轮分子泵，适用于高真空和超高真空应用，能够泵送任何类型的非腐蚀性和氧化性气体或气体化合物。

泵送作用通过由高性能电机驱动的高速涡轮（最大 **60600 rpm**）获得。它不含污染剂，因此适用于需要“清洁”真空的应用。

详细信息可参考“技术信息”章节。

## 安装

### 安装准备

TwisTorr 305-IC 具有特殊的保护包装。如果表现出在运输过程中可能发生损坏的迹象，请联系您当地的销售办事处。

避免因放下 305-IC 而对 305-IC 造成突然撞击。请注意保存好包装盒，以便在存放时间过长或运输时重复使用。

请勿以未经授权的方式处理包装材料。该材料是100%可回收的，符合 EEC指令94/62号和随后颁布的修正案。

#### 小心!

为了防止出现漏气问题，不要徒手处理将暴露在真空中的部件。始终使用手套或其他合适的防护装置。

#### 注意

正常暴露于环境中不会损坏 TwisTorr 305-IC。不过，还是建议将其密封在塑料袋中，直到安装到系统中为止，从而防止灰尘对其造成任何形式的污染。



图 1 TwisTorr 305-IC 包装

## 设置

**小心!**

305-IC 是一种对静电放电敏感的电子设备，因此，它被装在一个保护袋中，该保护袋的 USB 连接和 DB15 连接均带有保护盖。仅在将泵连接到控制器时才卸下这些保护盖。

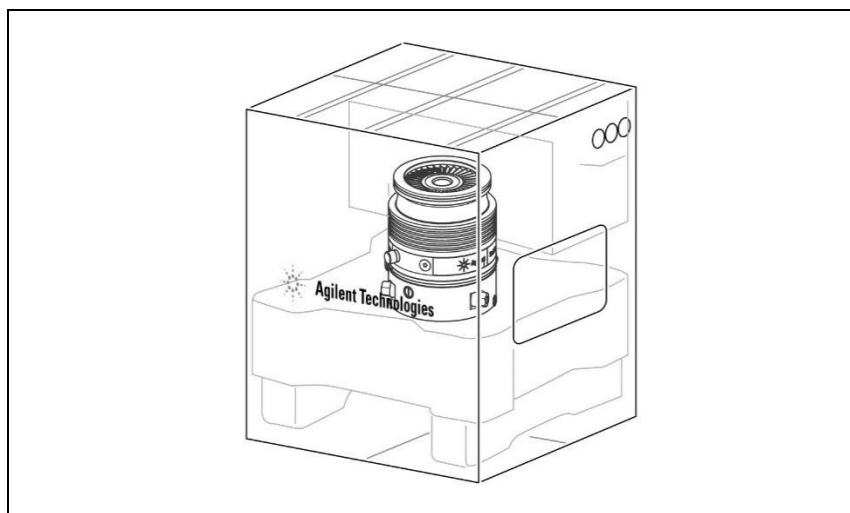
**小心!**

在准备好将涡轮泵安装到系统中之前，请勿拆下粘合剂和保护盖。



图 2

仅将本设备安装在室内，请勿在暴露于大气物质（雨、冰、雪）、灰尘、腐蚀性气体或爆炸性环境或高火灾风险的环境中使用泵。

在操作过程中，必须遵守以下环境条件，以避免冷凝：

- 最大环境压力：比大气压力高 2 bar
- 温度：从 +5 °C 到 +35 °C
- 相对湿度：0 ~ 90 %（非冷凝状态）。

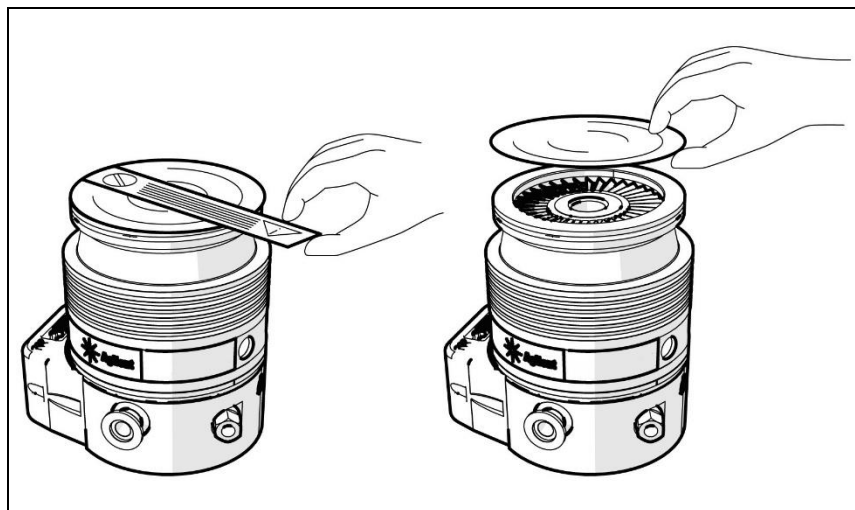
## TwisTor 305-IC 的安装

---

**警告!**



如果不遵守这些安装说明可能会导致泵在转子发生故障时与系统分离，从而导致财产损失或严重伤害或死亡。

---

TwisTorr 305-IC 可安装在任何位置。将TwisTorr 305-IC 固定在稳定位置，将涡轮泵的进气法兰安装到系统对接法兰上，其连接能够承受其轴周围 1000 Nm 的扭矩。

带有ConFlat 和 ISO K 入口法兰的涡轮泵必须通过适当的安捷伦硬件固定在真空室上。  
有关详细信息，请参阅" ConFlat 和 ISO K的安装"章节。

**小心!**

TwisTorr 305-IC 不能通过其底座进行固定

---

## 高真空法兰的连接

如果转子突然停止，则必须通过紧固高真空法兰的硬件来吸收产生的扭矩。  
螺栓或硬件必须符合以下规格。

**警告！**



必须以承受“使用说明”章节中指定的扭矩的方式连接泵。特别要注意  
夹具设计、夹具和螺栓的材料以及螺栓固定扭矩。  
仅使用高电阻级夹具（或螺栓） = 8.8。

**警告！**



如果泵固定在真空室上，其法兰与安捷伦推荐的法兰不同，则转子突然  
停止时，**305-IC** 将会有 扭曲或撕裂的可能性。不允许将不同法兰类型组  
合使用。安捷伦对因紧固不当造成的所有损害不承担任何责任。

## 5 使用说明

### ISO-K 法兰的安装

# ISO-K 法兰的安装

对于ISO-K法兰连接，请使用下图所示的IC63250DCMZ型夹具或等效夹具固定两个法兰（可选使用保护屏）。

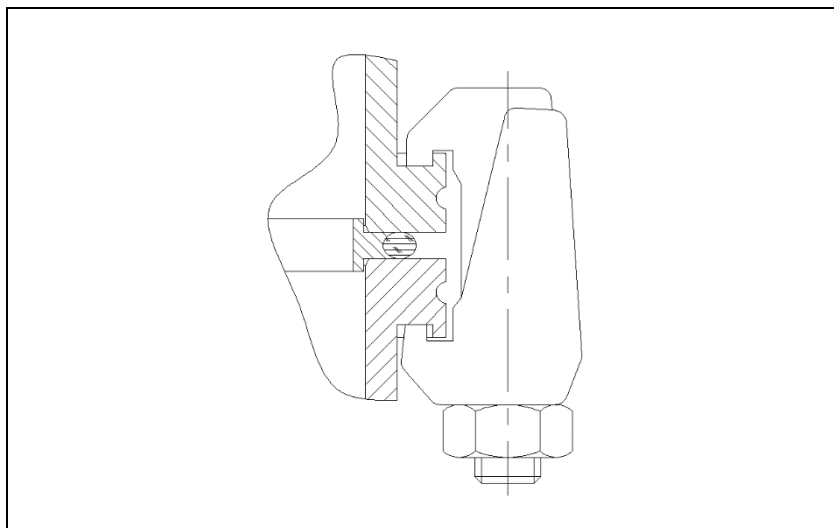

**图 3**

使用所需数量的夹钳：

- 4 表示 ISO 100 法兰
- 4 表示 ISO 160 法兰

以 22 Nm 的扭矩拧紧夹钳。

## ConFlat 法兰的安装

对于ConFlat法兰连接，请如下图所示用螺钉固定两个法兰（可以选择使用保护屏）。



图 4

使用所需数量的螺钉：

- 16 表示 CFF 6"
- 20 表示 CFF 8"

连接装置并依次拧紧每个螺钉。重复顺序拧紧，直到法兰面相重合。以 20 Nm 的扭矩拧紧螺钉。

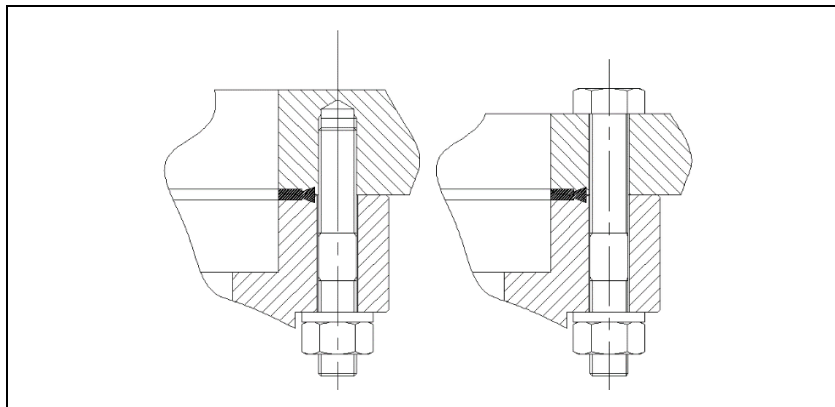
对于 ConFlat 法兰，我们建议仅使用高强度钢螺栓。

为了便于组装和拆卸，可以选择将 Felpro C-100 高温润滑剂涂在法兰突出的螺母上以及螺母与法兰之间的螺纹上。

在某些情况下，只能使用下侧的螺栓进行连接。

**小心!**

拧紧螺母和螺栓时应小心谨慎，避免在部件中造成凹痕。

## 前真空泵的连接

应使用 TwisTorr 305-IC 上提供的 KF 16 NW 法兰进行前级连接。与前级泵的连接可以通过真空额定软管或管道进行。如果使用刚性管道，则必须使用波纹管来抑制机械泵产生的任何振动。

### 注意

TwisTorr 305-IC 的特点是它对油蒸气的高压缩比。使用机械油封泵时，建议在涡轮泵和前真空泵之间安装合适的疏水阀，以防止干泵的机油或颗粒回流。

---

## TwisTorr 305-IC 的启动和运行

如要通过板载控制器启动TwisTorr 305-IC，请向泵提供适当的电源电压，并按照"启动(START)"和"互锁(INTERLOCK)"信号进行操作。识别这些信号后，控制器将启动泵。

### 注意

- (1) 为了查找电源电压输入引脚的位置（在输入/输出和电源连接器上），以及输入电压允许值，请参阅本说明手册中的"技术规格"章节和"输入/输出和电源"章节。
- (2) 为了查找启动/停止和互锁输入引脚的位置（在输入/输出和电源连接器上），以及相关的电气额定值，请参阅本说明手册的"输入/出站和电源"部分。
- (3) 要查找有关如何连接启动/停止和互锁信号的详细信息，请参阅本说明手册中的"如何连接控制器的集电极开路输入"章节。
- (4) TwisTorr 305-IC 配有 DB15 配对连接器，而不是预接线。该 DB15 配对连接器适合承受控制器供电所需的电流水平，并且与安装在控制单元上的 DB15 连接器完全兼容。在正确布线后，它既可用于将 TwisTorr 305-IC 连接到电源，也可以连接到附件部件（冷却风扇、排气阀）以及串行通信。









## 5 使用说明

### TwisTorr 305-IC 的启动和运行

**警告！**

泵的状态将由控制器上的 3 个 LED 灯显示。



LED 灯	象征	LED 状态	TON/TOFF	含义
绿色 		关	——	电源关闭
		开, 闪烁		305-IC 关闭, 状态: 停止/等待互锁/故障
		开, 反向闪烁		305-IC 打开, 目标速度尚未达到, 状态: 正在启动 (RAMP) /自动调谐
		开, 实心光		305-IC 打开, 达到目标速度, 状态: 正常操作。
		开, 闪烁		305-IC 打开, 减速, 状态: 制动
黄色 	△	关	——	无警告
		开, 实心光		警告
红色 	⚡	关	——	无故障
		开, 实心光		故障

注意

- (1) 如果检测到故障（红色 LED 灯，实心光），泵在收到启动命令时将无法旋转。用户可以通过串行通信检查错误消息并参考建议的操作列表来排除故障原因。检测到故障时，电子装置进入失效（FAIL）状态；排除故障原因后，设备需要接收新的启动命令以重置失效（FAIL）状态。因此，如果故障原因已解决，在收到新的启动命令后，红色指示灯状态将不均匀关闭，305 IC 将正常运行，以适合当前工作状态（RAMP，NORMAL 等）的状态显示（在串行通讯上，并通过绿色的 LED 灯指示）。
- (2) 如果检测到警告（黄色 LED 灯，实心光），泵可以在收到启动命令时正确旋转。用户可以通过串行通信检查错误消息并参考建议的操作列表来排除警告原因。检测到警告条件后，设备继续工作，没有中断，以适合当前工作状态（RAMP，NORMAL 等）的状态显示（在串行通讯上，并通过绿色的 LED 灯指示）。

这是因为警告与泵功能的任何停用条件均无关。解决警告的原因后，黄色 LED 指示灯将立即关闭，在大多数情况下，用户不需要在 305 IC 上进行任何进一步的操作，仅在极少数情况下，需要正确重置警告信号，用户必须关闭设备电源。

警告！



泵的初始启动将处于“慢启动”模式；有关此模式的详细信息，请参阅第 162 页的专用章节。

## 停止 TwisTorr 305-IC

如非紧急的情况下停止 305-IC，必须：

- a) 如果 305-IC 配置了远程模式，并且"互锁 (INTERLOCK)"设置为连续模式，则打开"启动 (START)"或"互锁 (INTERLOCK)"信号；
- b) 如果 305-IC 配置了远程模式，并且"互锁 (INTERLOCK)"设置为"脉冲模式"，则打开"启动 (START)"信号；
- c) 如果 305-IC 配置了串行模式，则向 305-IC 发送"停止 (STOP)"命令。

## 紧急停止

通过卸下电源可以实现紧急停止。

**警告！**



此模式仅在紧急情况下使用。使用此停止模式可能导致泵出现故障和/或损坏。不正确使用此停止模式可能会使保修失效。

## 维护

除非黄色 LED 指示灯打开，否则无需进行维护。如要检查错误，您可以通过串行连接读取代码。如果泵放置时间较长，建议对 DB15 连接进行目视检查，以确保其没有被氧化。  
任何其他维护必须由授权人员进行。

**警告!**



在对系统进行任何操作之前，将其从电源断开，用排气阀向泵排气，在转子完全停止后，等待泵的表面温度降低到 50°C 以下。

如果泵发生故障，您可以使用安捷伦维修服务或"安捷伦高级替换服务"，它会为您提供一个再制造系统，以取代故障的系统。发送订单后，用于替换的305-IC将被寄出。然后，您可以将出现故障的305-IC放入箱子以退回。

**注意**

在将泵退回给制造商进行维修或使用高级替换服务之前，必须填写并发送本说明手册上随附的"退货请求"表格。在装运前，必须在系统包装中插入相同的副本。

如果需要废除系统，请确保在遵守当地法规的情况下进行适当处置。

## 转子寿命

在理论的基础上估计，305-IC涡轮分子泵转子的抗疲劳性为从停止到全速再回到停止的405000次循环。

考虑到泵的通常使用情况以及安全限制，作为预防措施，安捷伦建议在使用 17 年后退回泵以进行维护。

## 慢启动

**警告!**



为确保轴承的正确润滑，泵具有被称为“慢启动”的默认设置。如果泵已长时间未被使用或在其初始启动状态，控制器将自动以慢启动模式启动。这种操作模式使产品需要较长时间内来达到速度。

用户无法停用此自动操作模式。用户可以决定始终以“慢启动模式”来启动产品，按照下面指定的相应串行命令来进行操作。

在长时间不活动之后，“软启动”模式可以正确分配轴承中存在的润滑脂。

在以下情况下，将自动激活“慢启动”模式：

- 1 初次启动;
- 2 在达到“全速”状态的最后一刻起的60天后。

**警告!**



此模式可以使用串行命令 **WIN100** 进行手动激活。

**WIN 100** 对于初次启动和在达到“全速”状态的最后一刻起的 60 天后的自动慢启动没有影响。

请参阅“Windows 协议”章节。

## 清洗

305-IC 的外表面只能用温和的洗涤剂清洗。

## 处置方式

### 标签中的"WEEE"徽标的含义

以下符号根据 EC WEEE（废弃电气和电子设备）指令进行应用。该符号（**仅在欧洲共同体国家有效**）表示其适用的产品不得与普通家庭或工业废物一起处理，而必须送往差别化废物收集系统。因此，请最终用户在检查合同销售条款和条件后，联系设备的供应商（无论是母公司还是零售商）启动收集和处置流程。



有关详细信息，请参阅：

<http://www.agilent.com/environment/product/index.shtml>

## 服务

如果客户需要高级替换或维修服务，请联系当地经销商或直接发送邮件至

[vpt-customer@agilent.com](mailto:vpt-customer@agilent.com)

[vpl-customer@agilent.com](mailto:vpl-customer@agilent.com)

需要填写退货申请表才能将泵退回到安捷伦维修部门（在本手册末尾会提供）。

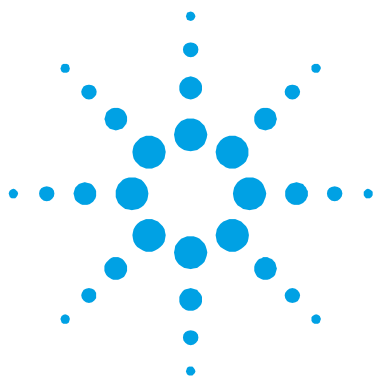

## 6 使用方法

このマニュアルについて	167
<b>有効性</b>	167
定義と用語	168
警告・注意・注の定義	168
警告の記号	169
<b>安全性</b>	171
<b>適切な使用</b>	171
<b>不適切な使用</b>	172
保護用装備	173
ターボ分子ポンプ用安全ガイドライン	175
移送&保管	176
製品説明	177
取り付け	178
取り付けの準備	178
セットアップ	180
<b>TwisTorr 305-IC 実装</b>	182
高真空フランジの接続	183
ISO-K フランジの取り付け	184
ConFlatフランジの取り付け	185
フォア真空ポンプの接続	186
<b>TwisTorr 305-ICの起動開始と操作</b>	187
<b>TwisTorr 305-ICを停止する</b>	190
緊急停止	190
メンテナンス	191
ローターの寿命	191
ソフトスタート	192
クリーニング	192
廃棄	193
サービス	194

## 6 TwisTorr 305-IC ユーザーマニュアル

## このマニュアルについて

### 有効性

このマニュアルは、特に安全、操作、またユーザーが負うべきメンテナンスの操作に限定される第一レベルのメンテナンスについての理解に関する **TwisTorr 305-IC** の使用者への説明を記載しています。

指定のセクションに説明されていますが、高いレベルのメンテナンス（メンテナンス操作に特定の訓練を受けた者）に関する特定の規定のメンテナンス操作は、使用者が実行してはいけません。

正しい取り付けと起動/停止については、「取り付け」の章をご確認ください。

更に詳細な技術的な使用には、「操作」の章をご確認ください。

#### 注

1. このマニュアルは、有益な情報を含んでいるため、全ての **TwisTorr 305-IC** の使用者は、製品寿命にわたり安全に操作することができ、また完全な能率性を保証します。
2. 全ての操作者/メンテナンス担当者が承知している入手しやすい場所に、全ての関係する書類と共にこのマニュアルを保管してください。

## 定義と用語

### 警告・注意・注の定義

このマニュアルのいくつかの重要な参照部は、対比色でハイライトされ枠で囲ってあります。

---

#### 警告!



「警告」のメッセージは、もし正しく操作されない場合に、重大な人身障害につながる可能性がある特定の操作や実行への操作者の注意の必要性を示しています。

---

#### 注意!

「注意」のメッセージは、もし監視されていない場合に装置に損害が生じる可能性を示しています。

---

#### 注

「注」は、重要な情報への注意喚起と特定の工程に関してのより詳細な情報を提供しています。

---

## 警告の記号

下記は、TwisTorr 305-IC上の警告と併せて表示される記号のリストです。危険性の説明も記載されています。

三角の記号は警告を示しています。説明書内または装置上の警告記号と併に示されうる記号の意味は下記の通りです：



直流



触らないでください



CE 適合宣言書



包括的な危険



製造所



電源オフ



電源オン



保護接地端子

## 6 使用方法

### 警告の記号

下記の記号は、装置に貼り付けられた警告ラベル上に使用されることがあります。もしこの記号を目視した場合、その警告ラベルに関する正しい工程のために、関連する操作またはサービスマニュアルを参照してください。



参考情報として、下記の記号は装置上に示されます。

	主要電源オン
	もし赤い場合、機能不良を意味します
	もし黄色い場合、警告を意味します
	USB ポート
	保護接地端子
	触らないでください
J1	主要コネクタ
NFC	近距離無線通信(スマートフォンのアンテナ)
CE	CE 認証
	CSA 認証
RoHS	EU RoHS 指令認証
	中国 RoHS 指令認証
	廃電気・電子製品に関する EU WEEE 指令

## 安全性

このセクションは、一般的、かつ機械の特定の使用に関する安全規定の遵守と監督に必須である機械指令（Machinery Directive 2006 / 42/ EC）の情報を含まず。

これらの指示とこのマニュアル内のその他の指示に従わなかった場合、設計時に予測された安全状態が非効率に損なわれ、機械を操作する者へ事故が生じる可能性があります。

アジレント・テクノロジー株式会社は、技術的な参照書に示された安全規定の不順守により派生した、機械または操作者もしくは第三者の身体的安全への損害・損傷の責任を全て拒否します。

## 適切な使用

このマニュアルは、装置一式が安全に機能するために遵守されるべき重要な警告と安全の手引きを含まず。

このマニュアルに説明されている製品は、説明書に特記されている分野への活用に限定した目的のものです。マニュアルはまた、製品の活用と操作に必須の要件に関する指示と標準の操作を保証するために適用される安全対策を提供します。アジレント・テクノロジー株式会社は、このマニュアル内説明されているもの以外の適用、または必須の要件や安全対策に注意が払われていない場合にいかなる保証も提供せず、またはいかなる責任も負いません。

製品は、損傷や怪我を生じさせない状況下において必要な安全対策を講じることができる有資格者のみ使用することができます。製品と併に使用されたいかなる付属品や機器も、アジレント・テクノロジー株式会社により共有もしくは承認されたものでなければなりません。

いかなる調整またはメンテナンスの操作は、リスクについて承知している専門家の技術者により実行されなければいけません。

製品の修理は、専らアジレント・テクノロジー株式会社により行われなければなりません。

## 不適切な使用

アジレント・テクノロジー株式会社は、TwisTorr 305-IC の不適切な使用により派生した全ての責任を拒否します。

不適切な使用は、責任と保証への全ての請求権が喪失します。不適切な使用は下記の通り定義されます：

- 不特定の取り付け用具を使用したポンプの取り付け
- 適切な浄化の流れなしに腐食性ガスや酸化ポンプすること（「腐食性ガスや酸化ガスとともに使用されるポンプ」を参照ください）
- 爆発性のガスをポンプすること
- 凝縮した蒸気をポンプすること
- 液体をポンプすること
- 粉末をポンプすること
- 不適切な高ガス量での操作
- 不適切な高圧補助真空での操作
- 実際に使用されるガスのもとは異なる選択されたガスのモダリティでの操作
- 不適切な高レベルの断熱材料での操作
- 不適切な高い磁界での操作
- 不敵な高い通気率での通気
- 圧力を生じさせるための真空ポンプの使用
- 電離放射線の範囲内での機器の操作
- 潜在的に爆発性がある範囲での操作
- 衝撃のある圧力や振動または定期的な力が機器に影響するシステム内での機器の使用

## 保護用装備

ポンプシステムのメンテナンスを操作または実行している操作者の保護装置は、実行される操作タイプに常に適切なものでなければなりません。

更に、それは機械が使用される該当国の法律に準拠する安全上の必要条件に従うものでなければなりません。一般的に。

一般的に、操作者は 305-IC を操作している時や取り付けの時に事故防止の靴を着用しなくてはなりません。



### 警告!

メンテナンスまたは取り付け時に、有害物質による健康への危険



過程の異常な点により、真空ポンプ、構成部分、または操作液は、有害物質、反応性物質、もしくは放射性物質に汚染される場合があります。

→ メンテナンスや修理、もしくは再度取り付け時には適切で十分な保護装備を着用してください。



### 警告!

装置の落下による損傷のリスク

真空ポンプを手で運搬する場合、荷重が滑り落ちる危険があります。



- 両手で小型・中型の真空ポンプを運んでください。
- 20 kg 以上のいかなる装置も、適切なリフトの機器を使用して運搬されなければなりません。
- 指令 EN 347 に従ったつま先キャップがスチール製の安全靴を着用してください。

## 6 使用方法

### 保護用装備



#### 注意!

#### 鋭い縁による損傷のリスク

ターボポンプのローターと固定子ディスクは、縁が非常に鋭くなっています。

- ポンプを修理する前、またはシステムからポンプのいかなる取り付け/取り外しをする前に、ポンプの完全な静止をお待ちください。
- 高真空フランジ内で直接操作しないでください。
- 必要に応じて、指令 EN 420 に従った保護手袋を着用してください。

## ターボ分子ポンプ用安全ガイドライン

下記の操作マニュアルに説明されるターボ分子ポンプは、それらローターの特定の質量との組み合わせで高回転速度により大量の運動エネルギーを含有します。

ポンプの機械的な部分の機能不良の場合、回転エネルギーはポンプが固定されているどの部分へも放出されています。

---

**警告!**



装置の損傷と操作者の怪我を避けるために、このマニュアルに記載された取り付けの指示に厳密に従ってください!

---

## 移送&保管

アジレントのターボ分子ポンプの最大レベルの性能と責任を保証するため、凝縮を避けるために下記のガイドラインに従わなければなりません：

- ポンプを輸送、移動、保存する時は、下記の環境仕様を超過してはいけません：
  - 温度範囲： -40 °C から 70 °C まで
  - 相対湿度範囲： 0 から 90 % まで（結露なし）
- ターボ分子ポンプの保存可能期間は出荷日から12ヶ月です。
- お客様がポンプを受け取ってから最初に操作する際には、ターボ分子ポンプは常にゆっくりと開始されなければなりません。
- ポンプを**60**日間月以上使用していない場合、ターボ分子ポンプは常にゆっくりと開始されなければなりません。

### 注意!

もしいかなる理由により保存可能期間を超過した場合、ポンプは工場へ返送されなければなりません。アジレントの現地の販売者やサービス担当者へ情報をお問い合わせください。

---

## 製品説明

この装置は専門家の使用向けで専門家により使用されることを対象としています。

**TwisTorr 305-IC** は、腐食性でないガスや酸化性でないガス、またはガス混合物のどんなタイプでもポンプ可能な、高真空・超高ターボ真空装置です。

ポンプの動作は、高性能電子モータにより駆動し高速タービン（最大 **60600 rpm**）により得られます。  
汚染物質がなく、ゆえに「清潔な」真空を必要とする活用に最適です。

より詳細な情報は、「技術的情報」のセクションに記載されています。

## 取り付け

### 取り付けの準備

TwisTorr 305-ICは、特別に保護された梱包により供給されます。もしこれに輸送中に発生した可能性のある損傷の跡がある場合、現地の販売営業所へお問い合わせください。

落下等による**305-IC** への突然の衝撃は避けてください。長期間の保存または輸送の場合のために、梱包ボックスを保持するようにご注意ください。

許可されていない方法で梱包材料を破棄しないでください。材料は**100%** リサイクルが可能で、**EEC指令94/62**とそれに準ずる改正を遵守しています。

#### 注意!

ガス放出の問題を避けるために、真空中に露出される構成部を素手で取り扱わないでください。常に手袋やその他適切な保護製品をご使用ください。

#### 注

通常環境への露出は、**TwisTorr 305-IC** を損傷しません。しかしながら、ちり・ホコリによるいかなる種類の汚染を防ぐので、システムに取り付けられるまでビニールの袋に密閉して保管することが推奨されます。



図 1 TwisTorr 305-IC の梱包

## 6 使用方法

### セットアップ

# セットアップ

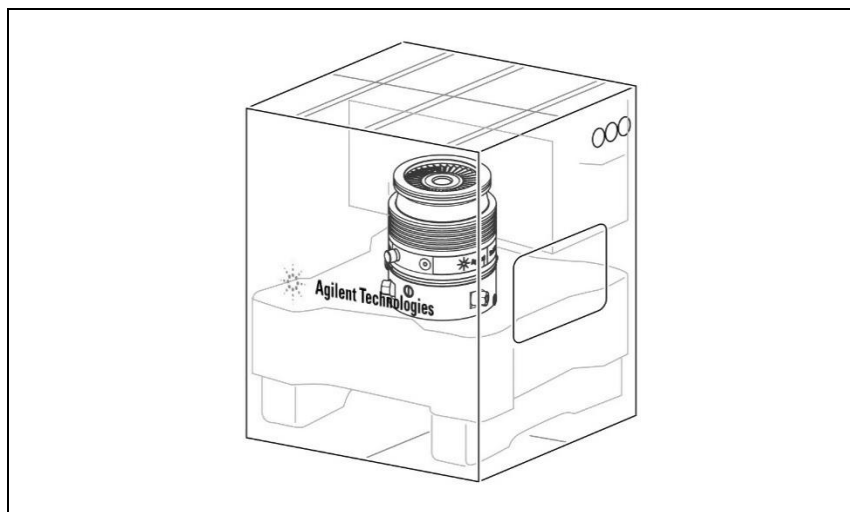
#### 注意!

305-1C は、静電放電に敏感な電子機器であり、この点において USB 接続と、また DB15 接続上でキャップ付きの保護バッグに入れて提供されています。ポンプをコントローラーに接続する時のみ、これらの保護キャップを取り外します。

#### 注意!

システムヘターボポンプを取り付ける準備ができるまで、粘着材と保護キャップを取り外さないでください。



図 2

この機器は屋内でのみ取り付けてください。また、ポンプを大気物質（雨、氷、雪）、ちり・ホコリ、侵略的ガスなどに露出する環境、または爆発の可能性がある環境、または燃えやすい環境下では使用しないでください。

操作中、凝縮をさけるために下記の環境状況は遵守されなければいけません：

- 最大環境気圧：大気圧上 2 バール
- 温度：+5 °C から +35 °C まで
- 相対湿度：0 – 90 %（結露なし）

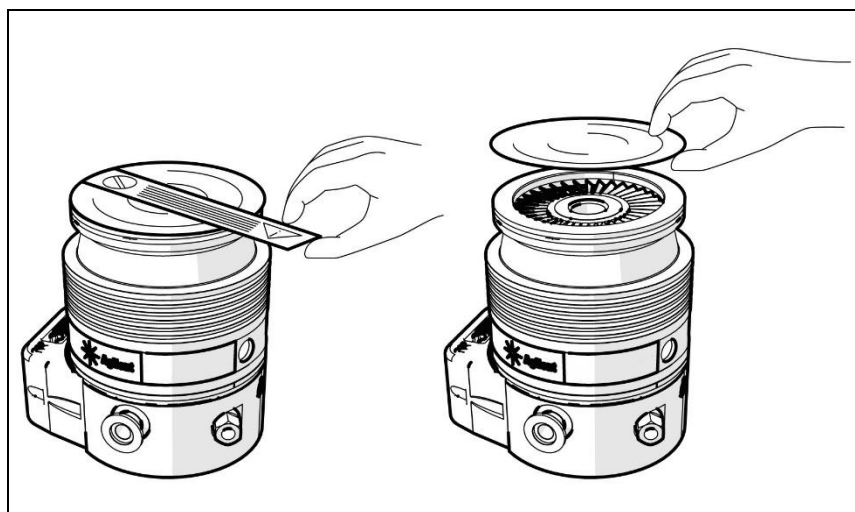
## TwisTorr 305-IC 実装

---

**警告!**



これらの取り付け説明が遵守されなかった場合、ローターの故障の際にシステムからのポンプの分離を引き起こし、それにより土地建物が損害を受けるか、重大な損傷や死亡事故につながる可能性があります。

---

TwisTorr 305-IC はどんな位置でも取り付けることができます。TwisTorr 305-IC を暗転した位置に固定し、軸回りに1000 Nmトルクの耐荷重の接続でターボポンプの吸気フランジをシステムの対フランジへはめま  
す。

ConFlat と ISO K 吸気フランジのターボポンプは、適切なアジレントのハードウェアを用いて真空チェンバーへ固定されなければなりません。  
更なる詳細は、「ConFlatとISO Kの取り付け」セクションをご覧ください。

**注意!**

TwisTorr 305-IC はその土台では固定できません。

---

## 高真空フランジの接続

もしローターが突然停止した場合、結果として生じるトルクは高真空フランジを留めているハードウェアにより吸収されなければいけません。

ボルトまたはハードウェアは下記の仕様に適合していなければいけません。

**警告!**



必ず「使用の説明」セクションに指定されているトルクに耐える方法でポンプを接続してはいけません。特に、クランプのデザイン、材料、ボルト、ボルトの固定トルクに注意してください。

高い耐荷重性クラスのクランプ（またはボルト）を使用してください  $\geq 8.8$ 。

**警告!**



もしポンプが、アジレントが推奨するものとは異なるフランジで真空チェンバー上に締め付けられた場合、ローターが突然停止した際に **305-IC** がねじ曲がるまたは引き裂かれる可能性があります。異なるフランジタイプの組み合わせは禁止されています。アジレントは不適切な締め付けにより生じた全ての損害・損傷にいかなる責任も負いません。

## 6 使用方法

### ISO-K フランジの取り付け

## ISO-K フランジの取り付け

ISO-K フランジの接続には、下記の図に示される通り、クランプのモデル IC63250DCMZ または同等のもので2つのフランジを固定します（オプションとして保護スクリーンを使用できます）。



図 3

必要な個数のクロークランプを使用してください：

- ISO 100 フランジ – 4個
- ISO 160 フランジ – 4個

クロークランプは、22 Nm のトルクできつく締めてください。

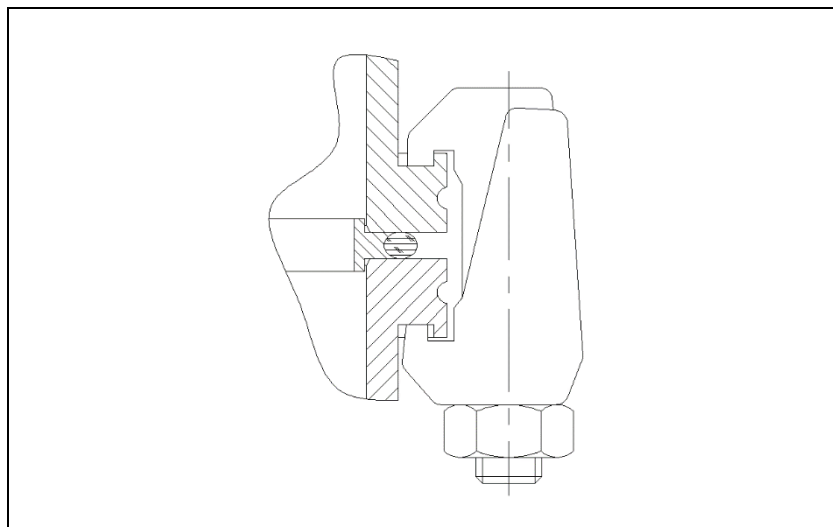
## ConFlat フランジの取り付け

ConFlat フランジの接続には、下記の図に示される通り、2つのフランジをネジで固定します（オプションとして保護スクリーンを使用できます）。



図 4

必要な個数のネジを使用してください：

- CFF 6" – 16個
- CFF 8" – 20個

ユニットをくっつけ、交互に各ネジを締めます。フランジの面が合うまで引き続き締め付けを繰り返します。20 Nm のトルクでネジを締めます。

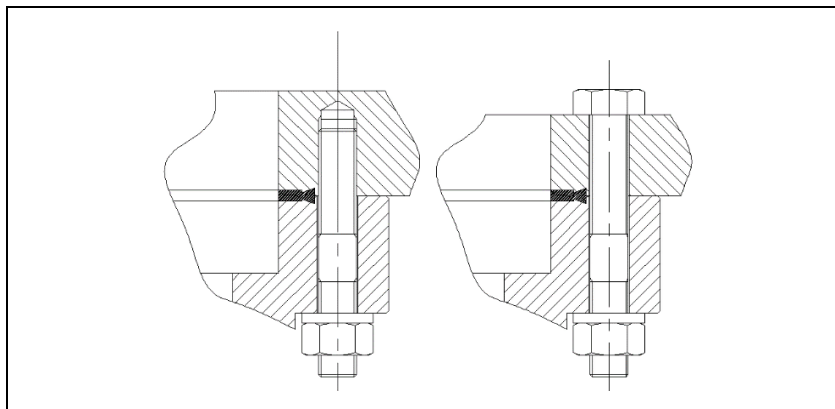
ConFlatフランジには、当社は高強度のスチールボルトのみを使用することを推奨します。

組み立てと解体を円滑にするため、オプションとしてFelpro C-100 高温潤滑剤をフランジから突き出ているネジ山と、ナットとフランジの間へ注入できます。

場合によっては、下側ではボルトでのみ接続できます。

### 注意!

ナットとボルトを締めるときは、エンベロープにへこみができないように注意してください。

## 6 使用方法

### フォア真空ポンプの接続

## フォア真空ポンプの接続

フォアラインの接続は、TwisTorr 305-IC 上に提供されるKF 16 NW フランジを使用して行ってください。フォアラインポンプの接続は、真空定格ホースまたはパイプで行うこともできます。もし硬いパイプが使用された場合、機械ポンプにより発生したいかなる振動も、下記の使用により減衰されなければなりません。

#### 注

TwisTorr 305-IC は、その高圧縮比とオイル蒸気が特徴的です。機械油密封式ポンプを使用する時、オイルまたは微粒子が乾燥したポンプより逆流するのを避けるために、ターボポンプと補助真空ポンプの間に適切なトラップを取り付けることを推奨します。

## TwisTorr 305-IC の起動開始と操作

搭載コントローラーを通してTwisTorr 305-IC を起動するには、適切な供給ボルテージでポンプを供給し、「開始」と「連動」信号で作動します。これらの信号が認識された後、コントローラーはポンプを開始します。

### 注

- (1) 供給ボルテージの出力ピン（イン/アウトと電源供給コネクタ上）の場所、また出力ボルテージの許容値を見つけるには、「技術仕様」とこの説明マニュアルの「イン/アウトとパワー供給」のセクションを参照してください。
- (2) 「開始/停止」と「連動」出力ピン（イン/アウトと電源供給コネクタ上）の場所、また関連する電気定格を見つけるには、この説明マニュアルの「イン/アウトとパワー供給」のセクションを参照してください。
- (3) 「開始/停止」と「連動」信号の接続の仕方の詳細を見つけるには、この説明マニュアルの「コントローラーのオープンコレクタ出力を接続する方法」のセクションを参照してください。
- (4) TwisTorr 305-IC は、組み合わせコネクタの DB15 が付属しており、ブレ配線はされていません。この DB15 組み合わせコネクタは、コントローラーに供給するのに必要な電流レベルに耐えるのに最適で、またコントロールユニットに備え付けられた DB15 コネクタに完全に互換性があります。TwisTorr 305-IC と供給ソースへの接続や付属部品（冷却ファン、通気弁）への接続両方、またシリアル通信への接続など、適切な配線の後に仕様できます。









## 6 使用方法

### TwisTorr 305-IC の起動開始と操作

**警告!**



ポンプの状態は、コントローラー上に 3 つの LED により表示されま  
す。

LED	記号	LED の状態	TON/TOFF	意味
緑 		オフ	—	電源オフ
		オン、点滅		305-IC オフ、状態: 停止/連動待機/故障
		オン、逆点滅		305-IC オン、目的速度にまだ到達していません、 状態: 開始中 (ランプ) / 自動チューニング
		オン、固定の点灯		305-IC オン、目的速度に到達しました、状態: 正常 OP.
黄色 	△	オフ	—	警告なし
		オン、固定の点灯		警告
赤 	⚡	オフ	—	機能不良なし
		オン、固定の点灯		機能不良

## NOTE

- (3) 機能不良（赤い LED、固定の点灯）が検出された場合、ポンプは開始のコマンドを受けても回転できません。使用者は、シリアル通信を經由したエラーメッセージを確認し、また推奨されるアクションリストを参照することにより、機能不良の事由を解決することができます。機能不良が検出された間、電子ユニットは「故障」状態になります；故障の事由が解決された後は、ユニットは、「故障」状態をリセットするために新しい開始コマンドを受けする必要があります。結果として、もし機能不良の事由が解決した場合、新しい開始コマンドを受け、正しく操作すると、電流作用状況に適切（ランプ、正常など）な状態（シリアル通信上と緑 LED の表示）を表示します。
- (4) 警告（黄色い LED、固定の点灯）が検出された場合、開始コマンドを受けるとポンプは正しく回転します。使用者はシリアル通信を經由したエラーメッセージを確認し、また推奨されるアクションリストを参照することにより、警告の事由を解決することができます。警告の状態が検出されると、ユニットは中断なしに動作を継続し、電流作用状況に適切（ランプ、正常など）な状態（シリアル通信上と緑 LED の表示）を表示します。

これは、警告はポンプの機能にいかなるブロッキング状態にも関係していないからです。警告の事由が解決された後は、黄色の LED ライトがすぐに消え、だいたいの場合には、使用者は 305 IC に何もそれ以上のアクションを行う必要はありません。ごくまれな場合に、警告信号を適切にリセットするために、使用者はユニットの電源をオフにしなければなりません。

## 警告!



ポンプの最初の起動開始は、「ソフトスタート」モードです；このモードのより詳細な情報は、特化したセクションの 192 ページを参照してください。

## 6 使用方法

### TwisTorr 305-IC を停止する

## TwisTorr 305-IC を停止する

緊急時ではない時に305-ICを停止するには、下記が必要です：

- a) もし305-ICが「リモートモード」に設定されている場合、また「連動」が「継続モード」に設定されている場合には、「開始」または「連動」信号を開いてください；
- b) もし305-ICが「リモートモード」に設定されている場合、また「連動」が「インパルスモード」に設定されている場合には、「開始」信号を開いてください；
- c) もし305-ICが「シリアルモード」に設定されている場合、305-ICへ「停止」コマンドを送信してください。

## 緊急停止

電源供給を切ることにより緊急停止します。

**警告!**



これは緊急時にのみ使用されるべきモードです。この停止モードの使用は、ポンプに障害及び/または損害が生じる可能性があります。この停止モードの不適切な使用は、保証が無効となりえます。

## メンテナンス

メンテナンスは、黄色いLEDがオン出ない限り必要ではありません。エラーを確認するために、シリアル接続を通したコードを読むことができます。もしポンプが長い時間不稼働であった場合、酸化がないことを確認するため、DB15接続の目視確認が推奨されます。

警告!



システム上でいかなる動作を実行する前に、電源供給を切り、通気弁でポンプを通気し、ローターが完全に停止して待ちポンプの表面温度が50°C以下になるまで待ってください。

ポンプが故障した場合、アジレントの修理サービスまたは、故障したシステムを取り替えてお客様へ再製造のシステムを提供する「アジレント最新交換サービス」を利用することができます。交換の305-ICは、ご注文がなされた時に郵送されます。そして、交換の305-ICが届いた箱に故障した305-ICを入れて返送してください。

注

製造者へ修理または最新交換サービスのためにポンプを返送する前に、この説明マニュアルに添付されている「返品申請」フォームを記入し、現地の販売事務所へ送信する必要があります。システムの梱包に、郵送する前に同フォームのコピーを入れてください。

もしシステムを廃棄する必要がある場合、適切な破棄のために現地の条例に従うようご確認ください。

## ローターの寿命

理論的評価による305-ICターボ分子ポンプローターの疲労抵抗は、停止状態から最大速度、さらに停止までの、ランプの405000サイクルです。

予防措置として、典型的なポンプの使用と安全制限を考慮に入れると、アジレントは17年間の使用後にメンテナンスのためポンプを返品することを推奨します。

## ソフトスタート

---

警告!



軸受部の適切な注油を確保するため、ポンプは「ソフトスタート」と呼ばれるデフォルト設定になっています。もしポンプが長期間不稼働だった場合、または最初の起動開始の場合、コントローラーは自動的にソフトスタートで開始します。この操作のモードにより、製品は長時間に渡って速度を上げます。

この自動操作モードは、使用者により設定解除できません。使用者は、下記に示される適切なシリアルコマンドで作動することで、常に「ソフトスタートモード」で製品を開始する決定ができます。

---

「ソフトスタート」モードは、長期間の不稼働後に、軸受部内の油の正確な再分配を可能にします。

「ソフトスタート」モードは、下記の場合に自動的にアクティベートされます:

- 1 最初の起動時;
- 2 「最大速度」状態になった最後の瞬間に達してから60日後。

警告!



このモードは、シリアルコマンドの **WIN100** を使用して手動でアクティベートできます。

**WIN 100** は、最初の起動開始時と「最大速度」の最後の瞬間から60日後の自動ソフトスタートには無効です。「ウィンドウズプロトコル」のセクションをご覧ください。

---

## クリーニング

305-ICの外側表面は中性洗剤でのみ、お手入れをすることができます。

## 廃棄

### ラベル上に表示された「WEEE」ロゴの意味

下記の記号はEC WEEE指令（電気電子廃棄物 指令）に従い適用されたものです。この記号（欧州諸共同体でのみ有効）は、製品は通常の家  
庭ゴミまたは産業廃棄物と一緒に廃棄されてはいけないこと、また分  
化された廃棄物収集システムへ送られなければいけないことを示しま  
す。従って、エンドユーザーは、販売の契約条件を確認した後に、収  
集と廃棄工程を始めるために、親会社かもしくは小売業者であらう  
と、機器の供給者へ問い合わせることが推奨されます。



さらなる情報は下記をご確認ください：

<http://www.agilent.com/environment/product/index.shtml>

## 6 使用方法

### サービス

## サービス

お客様が最新交換サービスまたは修理サービスが必要な場合は、現地代理店もしくは下記まで直接ご連絡ください:

[vpt-customer@agilent.com](mailto:vpt-customer@agilent.com)

[vpl-customer@agilent.com](mailto:vpl-customer@agilent.com)

返品フォームの申請の完了には、サービス提供のためにお客様のポンプをアジレント・テクノロジー株式会社へ返送する必要があります。  
(このマニュアルの最後に提供されています)。

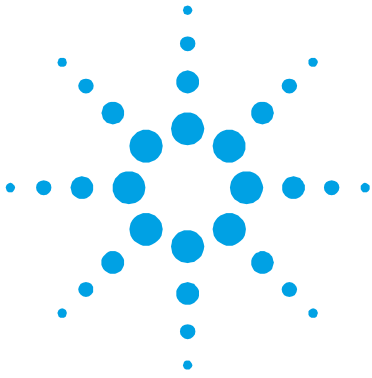

## 7

## Instructions for Use

About this manual	197
Validity	197
Definitions and terminology	198
Definition of Caution, Warning and Note	198
Warning Symbols	199
Safety	201
Proper Use	201
Improper Use	202
Protective equipment	203
Safety Guideline for Turbomolecular Pumps	205
Transport & Storage	206
Product description	207
Installation	208
Preparation for Installation	208
Set-up	210
TwisTorr 305-IC Mounting	212
Connection of the High Vacuum Flange	213
Installation of ISO-K Flange	214
Installation of ConFlat Flange	215
Connection of the Fore-Vacuum Pump	216
Startup and Operation of the TwisTorr 305-IC	217
Stopping the TwisTorr 305-IC	220
Emergency stop	220
Maintenance	221
Rotor life	221
Soft Start	222
Cleaning	222
Disposal	223
Service	224



## About this manual

### Validity

This manual lists the instructions for the users of the TwisTorr 305-IC, with particular reference to the notions relating to safety, operation and first level maintenance, limited to maintenance operations for which the user is responsible.

The maintenance operations, illustrated in the specific sections, with specific provisions relating to the higher level of maintenance (personnel specifically trained for maintenance operations) must not be carried out by the user.

For a correct installation and start/stop, please refer to "Installation" chapter.

For more detailed technical use, please refer to "Operations" chapter.

#### NOTE

1. This manual contains useful information so that all personnel using the TwisTorr 305-IC can operate it safely and guarantee perfect efficiency, for its entire life span.
  2. Keep this manual, together with all the related publications, in an accessible place known to all operators/maintenance personnel.
-

## Definitions and terminology

### Definition of Caution, Warning and Note

Some important references of this manual are highlighted and framed in contrasting colour.

---

**WARNING!**



Warning messages draw the operator's attention to a specific procedure or practice which, if not performed correctly, could result in serious personal injury.

---

**CAUTION!**

Caution messages are displayed before procedures which, if not observed, could cause damage to the equipment.

---

**NOTE**

Notes are intended to call attention to important information and provide more detail regarding specific steps.

---

## Warning Symbols

The following is a list of symbols that appear in conjunction with warnings on the TwisTorr 305-IC. The hazard they describe is also shown.

A triangular symbol indicates a warning. The meanings of the symbols that may appear alongside warnings in the documentation or on the instrument itself are as follows:

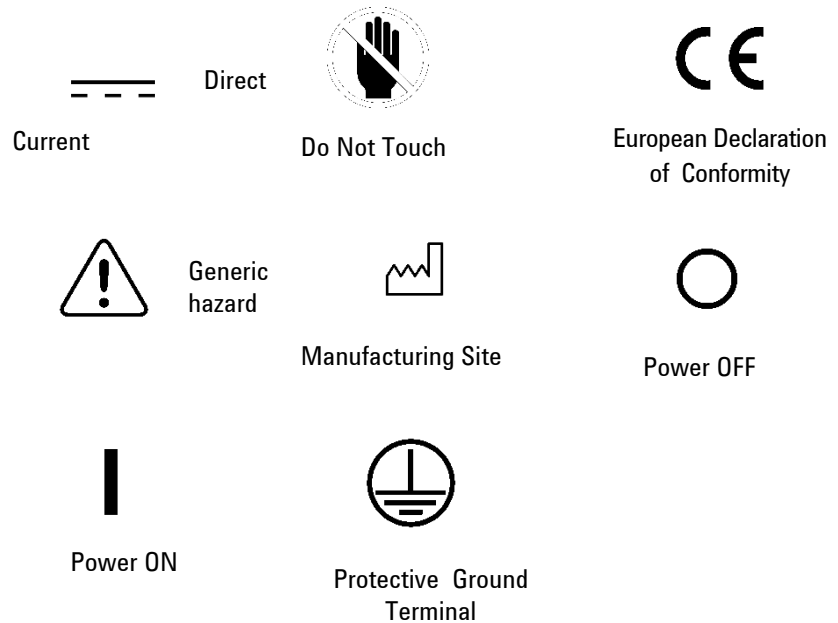









## 7 Instructions for Use

### Warning Symbols

The following symbol may be used on warning labels attached to the instrument. When you see this symbol, refer to the relevant operation or service manual for the correct procedure referred to by that warning label.



The following symbols appear on the instrument for your information.

	Mains power on
	If red, it means malfunction
	If yellow, it means warning
	USB port
	Protective Ground Terminal
	Do Not Touch
J1	Main connector
NFC	Near Field Communication (smartphone's antenna)
CE	CE certification
	CSA certification
RoHS	Restriction of Hazardous Substances certification
	RoHS China certification
	Waste Electrical and Electronic Equipment

## Safety

This section contains the information, prescribed by the Machinery Directive 2006/42/EC, which is essential for the compliance and observance of the safety regulations both generally and in relation to the specific use of the machine.

Failure to comply with these instructions and the other instructions contained in this manual may render the safety conditions envisaged in the design phase inefficient and cause accidents to those operating the machine.

Agilent Technologies declines all responsibility for damage to the machine or for the physical safety of the operator or third parties deriving from the non-observance of the safety rules indicated in the technical documentation.

## Proper Use

This manual contains important warnings and safety instructions to be observed in order for the unit to work safely.

The product described in this manual is intended exclusively for the area of application specified in the instructions. The manual also provides indications regarding the essential requirements for the application and operation of the product as well as the safety measures that can be adopted to guarantee regular operation. Agilent Technologies does not provide any guarantee or assume any responsibility for applications other than those described in this manual or in which the essential requirements and safety measures are not respected.

The product must only be used by qualified personnel who are able to take the necessary safety measures under conditions that do not cause damage or injury. Any accessories and equipment used with the product must be supplied or approved by Agilent Technologies.

Any adjustment or maintenance operation must be performed by a professional technician informed about the risks.

Repairs on the product must be carried out exclusively by Agilent authorized personnel.

## **Improper Use**

Agilent Technologies declines all responsibility, deriving from the improper use of the TwisTorr 305-IC.

Improper use will cause all claims for liability and warranties to be forfeited. Improper use is defined as:

- installation of the pump with unspecified mounting material
- pumping corrosive and oxidizing gases w/o proper purge flow (see section "Pump used with corrosive and oxidizing gases")
- pumping of explosive gases
- pumping of condensing vapors
- pumping of liquids
- pumping dust
- operation with improper high gas throughput
- operation with improper high fore-vacuum pressures
- Operation with selected gas modality different from the gas actually used
- operation with improper high levels of insulated heat input
- operation in improper high magnetic fields
- venting with improper high venting rates
- use of the vacuum pump to generate pressure
- operation of the device in areas with ionizing radiation
- operation in potentially explosive areas
- use of the device in systems in which impact-like stress and vibrations or periodic forces affect the device.

## Protective equipment

The protective equipment of the operators who are operating or executing the maintenance of the pumping system must always be adequate for the type of operation being executed. Furthermore, it must comply with the safety requirements of the legislation in force in the country in which the machine is used.

In general, the operator must wear accident-prevention shoes while handling the 305-IC and during installation.



**WARNING!**

**Danger to health by hazardous substances during maintenance or installation**

Depending on the process peculiarity, vacuum pumps, components or operating fluids can be contaminated by toxic, reactive or radioactive substances.

- Wear adequate protective equipment during maintenance and repairs or in case of reinstallation.



**WARNING!**

**Risk of injury through falling objects**

When transporting vacuum pumps by hand, there is a danger through loads slipping and falling down.

- Carry small and mid-size vacuum pumps two-handed.
- Any equipment heavier than 20 kg should be transported using a suitable lifting device.
- Wear safety shoes with steel toe cap according to directive EN 347.

## 7 Instructions for Use

### Improper Use



---

**CAUTION!****Risk of injury through sharp edges**

Rotor and stator disks of turbopumps have very sharp edges.

- Before servicing the pump or before any mounting/ dismounting action of the pump from the system, wait for the complete standstill of the pump.
  - Do not operate directly inside the high vacuum flange.
  - If necessary wear protective gloves according to EN 420.
-

## Safety Guideline for Turbomolecular Pumps

Turbomolecular pumps as described in the following operating manual contain a large amount of kinetic energy due to the high Rotation Speed in combination with the specific mass of their rotors.

In case of malfunctioning of a mechanical part of the pump the rotational energy may be released to whatever the pump is fixed to.

---

**WARNING!**



**To avoid damage to equipment and to prevent injuries to operating personnel the installation instructions as given in this manual should be strictly followed!**

---

## Transport & Storage

In order to guarantee the maximum level of performance and reliability of Agilent Turbomolecular pumps, the following guidelines must be followed to avoid condensation:

- when shipping, moving and storing pumps, the following environmental specifications should not be exceeded:
  - temperature range: -40 °C to 70 °C
  - relative humidity range: 0 to 90 % (non condensing).
- the shelf life of a turbomolecular pump is 12 months from the shipping date.
- the turbomolecular pumps must be always soft-started when received and operated for the first time by the customer.
- the turbomolecular pumps must be always soft-started after a period of 60 days of inactivity of the pump.

### CAUTION!

If for any reason the shelf life time is exceeded, the pump has to be returned to the factory. Please contact the local Agilent Vacuum Sales and Service representative for information.

---

## Product description

This equipment is intended for professional use and to be used by professionals.

The TwisTorr 305-IC is a turbomolecular pump for high and ultrahigh vacuum applications which is able to pump any type of non corrosive and oxidizing gas or gas compound.

The pumping action is obtained through a high speed turbine (max. 60600 rpm) driven by a high-performance electric motor.

It is free of contaminating agents and, therefore, is suitable for applications requiring a "clean" vacuum.

Detailed information is supplied in the "Technical Information" section.

## Installation

### Preparation for Installation

The TwisTorr 305-IC is supplied in a special protective packaging. If this shows signs of damage which may have occurred during transport, contact your local sales office.

Avoid sudden impacts to the 305-IC that would be caused by dropping it. Be aware to maintain the packaging box in order to reuse it in case of storage for a long period of time or in case of shipping.

Do not dispose of the packing materials in an unauthorized manner. The material is 100% recyclable and complies with EEC Directive 94/62 and subsequent amendments.

#### CAUTION!

In order to prevent outgassing problems, do not use bare hands to handle components which will be exposed to vacuum. Always use gloves or other appropriate protection.

---

#### NOTE

Normal exposure to the environment cannot damage the TwisTorr 305-IC. Nevertheless, it is advisable to keep it sealed in its plastic bag until it is installed in the system, thus preventing any form of pollution by dust.

---

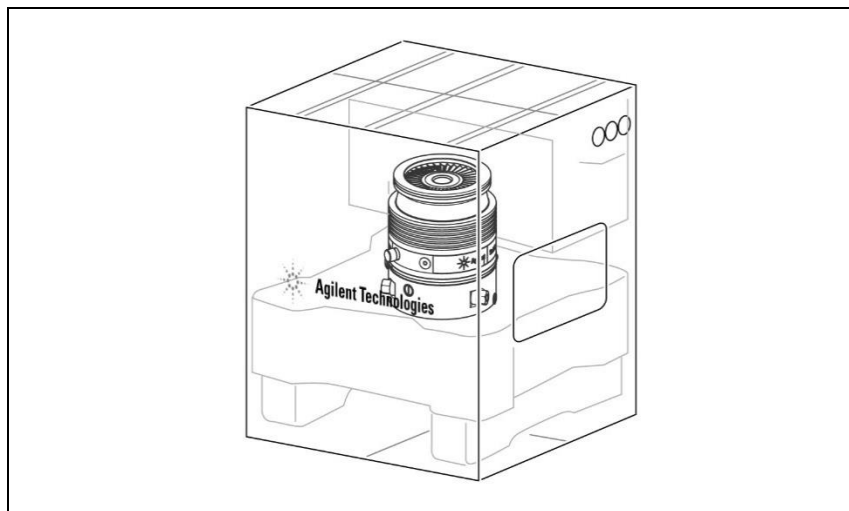

**Figure 1** TwisTorr 305-IC packaging

## 7 Instructions for Use

### Set-up

# Set-up

#### CAUTION!

The 305-IC is an electronic device sensitive to electrostatic discharges, and, to this point, it is supplied in a protective bag with caps on the USB connection as well as on the DB15 connection. Remove these protective caps only when connecting the pump to the controller.

#### CAUTION!

Do not remove the adhesive and protective cap until you are ready to install the turbopump to the system.

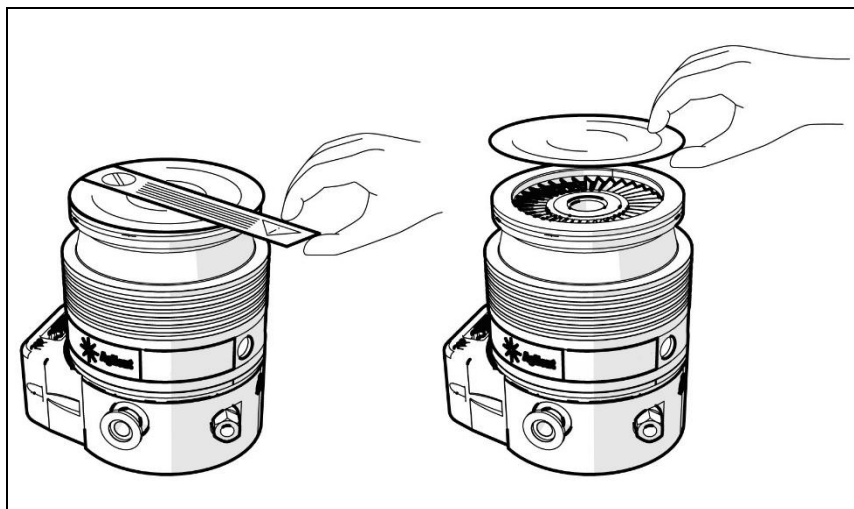

Figure 2

Install this device indoors only, and do not use the pump in an environment exposed to atmospheric agents (rain, ice, snow), dust, aggressive gases, or in explosive environments or those with a high fire risk.

During operation, the following environmental conditions must be complied with in order to avoid condensation:

- maximum ambient pressure: 2 bar above atmospheric pressure
- temperature: from +5 °C to +35 °C
- relative humidity: 0 – 90 % (non-condensing).

## TwisTorr 305-IC Mounting

---

**WARNING!**



Failure to comply with these installation instructions could result in the pump detaching from the system in the event of a rotor failure, which could cause property damage or serious injury or death.

---

The TwisTorr 305-IC can be installed in any position. Fix the TwisTorr 305-IC in a stable position, mounting the inlet flange of the turbopump to the system counter-flange, with a connection capable of withstanding a torque of 1000 Nm around its axis.

The turbopump with ConFlat and ISO K inlet flange must be fixed to the vacuum chamber by means of the appropriate Agilent hardware.  
For further details see the “Installation of ConFlat and ISO K” section.

**CAUTION!**

The TwisTorr 305-IC cannot be fixed by means of its base

---

## Connection of the High Vacuum Flange

If the rotor stops suddenly, the resulting torque must be absorbed by the hardware fastening the high vacuum flange.

Bolts or hardware must meet the specification below.

---

**WARNING!**



It is mandatory to connect the pump in such a way to withstand the torque specified in the "INSTRUCTION FOR USE" section. Specifically pay attention to clamp design, material of clamps and bolts and bolt fixing torque. Use only high resistance class clamps (or bolts)  $\geq 8.8$ .

---

---

**WARNING!**



If the pump is fastened on a vacuum chamber with flanges different from those recommended by Agilent, there is the chance of the 305-IC twisting or tearing-off in case the rotor suddenly stops. The combination of different flange types is not allowed. Agilent will not accept any liability for all damages resulting from improper fastening.

---

## Installation of ISO-K Flange

For ISO-K flange connections, fix the two flanges with the clamps model IC63250DCMZ or equivalent, as shown in the following figure (a protective screen can optionally be used).

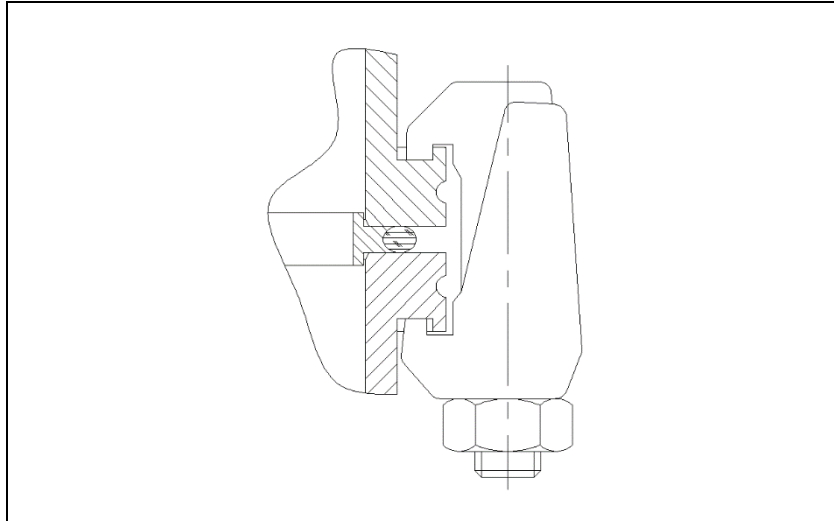

**Figure 3**

Use the required number of claw clamps:

- 4 for ISO 100 flange
- 4 for ISO 160 flange

Tighten the claw clamps with a torque of 22 Nm.

## Installation of ConFlat Flange

For ConFlat flange connections, fix the two flanges with the screws as shown in the following figure (a protective screen can optionally be used).

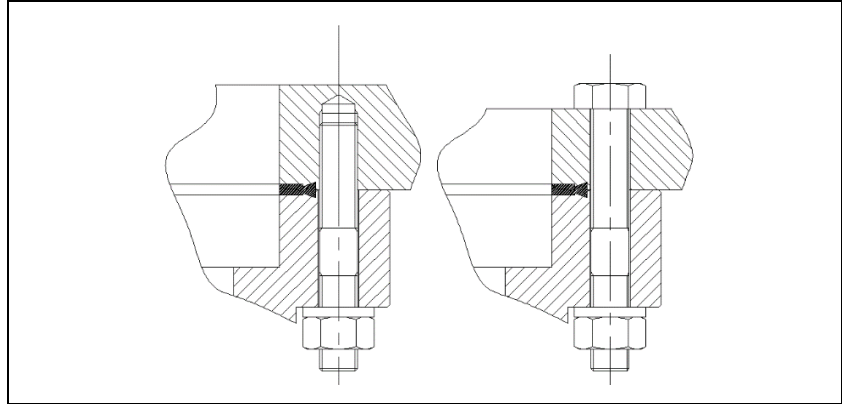

**Figure 4**

Use the required number of screws:

- 16 for CFF 6"
- 20 for CFF 8"

Attach the units and tighten each screw in turn. Repeat the sequential tightening until the flange faces meet. Tighten the screws with a torque of 20 Nm.

For ConFlat flange we recommend the usage of high strength steel bolts only. To facilitate assembly and dismantling, it is optional to apply Felpro C-100 high temperature lubricant to the screw threads protruding from the flange and between the nuts and flange.

In some cases, the connections can be made only with the bolt in the lower side.

**CAUTION!**

Exercise care when tightening nuts and bolts to avoid creating dents in the envelope.

## Connection of the Fore-Vacuum Pump

The foreline connection should be made using the KF 16 NW flange provided on the TwisTorr 305-IC. The connection to the foreline pump can be made by a vacuum rated hose or pipe. If a rigid pipe is used, any vibration generated by the mechanical pump must be damped through the use of bellows.

**NOTE**

The TwisTorr 305-IC is characterized by its high compression ratio also for oil vapors. When using a mechanical oil-sealed pump, it is advisable to install a suitable trap between the turbopump and the fore-vacuum pump in order to prevent back streaming oil or particulate from dry pumps.

---

## Startup and Operation of the TwisTorr 305-IC

To turn on the TwisTorr 305-IC via the on board controllers, supply the pump with the proper supply voltage and then act on the "START" and "INTERLOCK" signals. Once these signals are recognized the controller will start the pump.

### NOTES















- (1) In order to find the location of the supply voltage input pins (on the IN/OUT and Power Supply Connector), as well as the input voltage admitted values, please refer to "Technical Specifications" section and to "IN/OUT and Power Supply" section of this instruction manual.
  - (2) In order to find the location of the START/STOP and INTERLOCK input pins (on the IN/OUT and Power Supply Connector), as well as the related electrical ratings, please refer to the "IN/OUT and Power Supply" section of this instruction manual.
  - (3) In order to find details about how to connect the START/STOP and the INTERLOCK signals, please refer to the "How to Connect the Open Collector Inputs of the Controller" section of this instruction manual.
  - (4) The TwisTorr 305-IC is provided with a DB15 mating connector, not pre-wired. This DB15 mating connector is suitable to withstand to the current level needed to supply the controller and it is fully compatible with the DB15 connector which is mounted on the control unit. It can be used, after properly wiring, both to connect the TwisTorr 305-IC to the supply source as well as to the accessory parts (cooling fan, vent valves) and also to the serial comm.
-

**7 Instructions for Use**  
**Startup and Operation of the TwisTorr 305-IC**

**WARNING!**

The status of the pump will be displayed by the 3 LEDs on the controller.



LED	SYMBOL	LED STATUS	TON/TOFF	MEANING
Green 		Off		Power Off
		On, flashing		305-IC OFF, status: STOP/WAITING INTERLOCK/FAIL
		On, invers flashing		305-IC ON, target speed not yet achieved, status: STARTING (RAMP)/AUTO TUNING
		ON, Solid light		305-IC ON, target speed achieved, status: NORMAL OP.
		On, blinking		305-IC ON, speed reduction, status: BRAKING
Yellow 		Off		No Warning
		ON, Solid light		Warning
Red 		Off		No Malfunction
		ON, Solid light		Malfunction

**NOTE**

- (3) In case a Malfunction (Red LED, ON Solid light) is detected, the pump cannot spin upon receiving the start command. The user can troubleshoot the reason for the malfunction by checking the error messages via serial communication and also referring to the list of suggested actions. While a malfunction is detected, the electronic unit enters in the FAIL status; once the reason for the fail has been trouble shooted, the units needs to receive a new start command in order to reset the FAIL status. As a consequence, if the reason for the malfunction has been solved, upon the receiving of the new START command, the red led light status will be immedi atelyturned off and the 305 IC will operate properly, showing the status (on the serial comm. and by the green led indicatio ns) which is appropriate to the current work condition (RAMP, NORMAL, etc.).
- (4) In case a Warning (Yellow LED, ON Solid light) is detected, the pump can spin properlyupon receiving the start command. The user can troubleshoot the reason for the warning by checking the error messages via serial communication and also referring to the list of suggested actions. Upon the detection of a warning condition, the unit continues to work with no interruptions and showing the status (on the serial comm. and by the green led indications) which is approp riate to the current work condition (RAMP, NORMAL, etc..).  
This because, warnings are not related to any blocking conditions for th e pump functionality. Once the reason for the warning has been solved, the yellow led light will be immediatelyturned off, and in the majorityof the cases, the user do not need to perform any further action on the 305 IC Only in a very few cases, in order to properly reset the warning signal, the user has to power off the unit.
- 

**WARNING!**

**The initial startup of the pump will be in "SOFT START" mode; for detailed information on this mode refer to the dedicated section on page 222.**

---

## Stopping the TwisTorr 305-IC

To stop the 305-IC, not in emergency, it is necessary to:

- a) if the 305-IC is configured in REMOTE MODE, and the INTERLOCK is set to CONTINUOUS MODE, then open the "START" or the "INTERLOCK" signals;
- b) if the 305-IC is configured in REMOTE MODE, and the INTERLOCK is set to IMPULSE MODE, then open the START signal;
- c) if the 305-IC is configured in SERIAL Mode, then send a STOP command to the 305-IC.

## Emergency stop

Emergency stop can be achieved by removing the power supply.

---

**WARNING!**



**This mode is to be used only in an emergency. The use of this stop mode could lead to faults and/or damages at the pump. Improper use of this stop mode could void the warranty.**

---

## Maintenance

Maintenance is not required unless the yellow LED is on. To check the error you can read the code via serial connection. If a pump sits for a prolonged amount of time, a visual check of the DB15 connection is recommended to make sure it is free of oxidation. Any other maintenance must be performed by authorized personnel.

---

**WARNING!**



**Before carrying out any work on the system, disconnect it from the power supply, vent the pump with the vent valve, wait until the rotor is completely stopped and wait until the surface temperature of the pump is below 50° C.**

---

In the event the pump fails, you can use the Agilent repair service or the “Agilent advanced exchange service”, which gets you a remanufactured system to replace the failed system. The exchange 305-IC is shipped when the order is placed. You then return the failed 305-IC in the box that the exchange 305-IC comes in.

---

**NOTE**

Before returning a pump for repair or advanced exchange service to the manufacturer, it is essential to complete and send to the local sales office the “Request for Return” form attached to this instruction manual. Copy of the same must be inserted in the packaging of the system before shipping.

---

If a system needs to be scrapped, ensure that local regulations are followed for appropriate disposal.

## Rotor life

The fatigue resistance of 305-IC turbomolecular pump rotor resulting from theoretical evaluation is 405000 cycles of ramp up from stop to full speed and back to stop.

As a precautionary measure, considering the typical usage of the pump and taking into account safety limits, Agilent recommends to return the pump after 17 years of use for maintenance.

## Soft Start

---

**WARNING!**



To ensure proper lubrication of the bearings the pump has a default setting called soft start. If the pump has been sitting for an extended period or on its initial startup the controller will automatically start in soft start. This mode of operation brings the product up to speed over an extended amount of time.

**This automatic operating mode cannot be deactivated by the user. The user can possibly decide to start the product always in "soft start mode", acting on an appropriate serial command, as specified below.**

---

The "Soft Start" mode allows the correct redistribution of the grease present in the bearings, after a long period of inactivity.

The "Soft Start" mode is automatically activated in the following cases:

- 1 At the first starting;
  - 2 After 60 days from reaching the last moment in "FULL SPEED" condition.
- 

**WARNING!**



**This mode can be activated manually using the serial command WIN100. The WIN 100 has no effect on the automatic soft start at the first starting and after 60 days from the last moment in FULL SPEED. See "Windows Protocol" section.**

---

## Cleaning

The exterior surface of the 305-IC may be cleaned with mild detergent only.

## Disposal

### Meaning of the "WEEE" logo found in labels

The following symbol is applied in accordance with the EC WEEE (Waste Electrical and Electronic Equipment) Directive. This symbol (**valid only in countries of the European Community**) indicates that the product it applies to must NOT be disposed of together with ordinary domestic or industrial waste but must be sent to a differentiated waste collection system. The end user is therefore invited to contact the supplier of the device, whether the Parent Company or a retailer, to initiate the collection and disposal process after checking the contractual terms and conditions of sale.



For more information refer to:

<http://www.agilent.com/environment/product/index.shtml>

## **Service**

Should a customer need an advanced exchange or repair service, please contact local distributor or directly mail to

[vpt-customercare@agilent.com](mailto:vpt-customercare@agilent.com)

[vpl-customercare@agilent.com](mailto:vpl-customercare@agilent.com)

Completion of the Request for Return form is required to return your pump to Agilent for service (provided at the end of this manual).

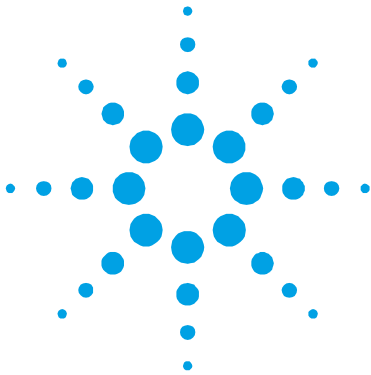

## 8

## Technical Information

Description of the TwisTorr 305-IC	227
Technical Specification	233
TwisTorr 305-IC Outline	236
Pump Operations	247
Inlet screen installation	247
Air Cooling Kit Installation (only for air cooled pumps)	250
Assembling procedure Air Cooling Kit X3500-68010	251
Water Cooling Kit Connection (only for water cooling pumps)	255
Vent Accessories	258
Pump Used with Corrosive and Oxidizing Gases	261
Purge Valve Installation	263
Pump Used in Presence of Magnetic Fields	264
Vibration Isolator Installation	264
Controller Operations	265
Interconnections	265
1 - Vent	266
2 - External Fan	266
3 - IN/OUT and Power Supply	266
Signal Description	268
How to Connect the Open Collector	
Inputs of the Controller	272
How to Connect the Controller Outputs	273
RS485/RS232 communication description	274
Windows Protocol	276
Window Description	281
NFC Function	287
Screenshot APP	289

Connection through USB plug	290
Error messages	291
Warning messages	293
Accessories and Spare Parts	295

## Description of the TwisTorr 305-IC

The TwisTorr 305-IC consists of a high frequency induction motor driving a turbine fitted with 8 bladed stages and 3 TwisTorr drag stages. The turbine rotates in an counterclockwise direction when viewed from the high vacuum flange end.

The turbine is made of high strength aluminum alloy, machined from a single block. The TwisTorr stages are in the form of three disks.

The turbine rotor is supported by permanently lubricated high precision ceramic ball bearings installed on the fore-vacuum side of the pump.

The static blades of the stator are made of stainless steel. These are supported and accurately positioned by spacer rings.

The TwisTorr stators are in the form of selfpositioning machined disks. On each disk there are parallel spiral pumping channels designed to pump in centrifugal direction on one side and in centripetal direction on the other side. These are made of an aluminum alloy.

During normal operation, the motor is driven at 1010 Hz.

---

**WARNING!**

**Always ensure the pump is receiving proper cooling during operations. Improper cooling could result in damage to the pump.**

---

According to the list in the following page, different P/Ns are available for:

- Air cooling (air cooling kit X3500-68010 and adapter kit X3514-68001 are recommended)
- Water cooling (water cooling kit 9699337 is recommended).

The pump is protected from overheating by a thermistor mounted inside the pump. The signal from the thermistor is continuously monitored by the pump's electronic control unit.

If the thermistor reading exceeds the predefined maximum level threshold or it is lower than the minimum level threshold, the 305-IC stops with 2 different error codes (see controller paragraph).

The pump can operate in any position but is required to be supported by the high vacuum flange. The connection of the fore-vacuum on the side of the pump is a KF 16 NW flange (KF25 – optional).

## 8 Technical Information

### Description of the TwisTorr 305-IC

The TwisTorr 305-IC is available in various models that differ in the high vacuum flange.

The TwisTorr 305-IC models are:

X3513-64000	TWISTORR 305-IC ISO100K 485AGI AIR COOLING
X3513-64001	TWISTORR 305-IC CFF6 485AGI AIR COOLING
X3513-64002	TWISTORR 305-IC ISO160K 485AGI AIR COOLING
X3513-64003	TWISTORR 305-IC CFF8 485AGI AIR COOLING
X3513-64004	TWISTORR 305-IC ISO100K 485AGI WATER COOLING
X3513-64005	TWISTORR 305-IC CFF6 485AGI WATER COOLING
X3513-64006	TWISTORR 305-IC ISO160K 485AGI WATER COOLING
X3513-64007	TWISTORR 305-IC CFF8 485AGI WATER COOLING
X3513-64016	TWISTORR 305-IC ISO100K 485P AIR COOLING
X3513-64017	TWISTORR 305-IC CFF6 485P AIR COOLING
X3513-64018	TWISTORR 305-IC ISO160K 485P AIR COOLING
X3513-64019	TWISTORR 305-IC CFF8 485P AIR COOLING
X3513-64020	TWISTORR 305-IC ISO100K 485P WATER COOLING
X3513-64021	TWISTORR 305-IC CFF6 485P WATER COOLING
X3513-64022	TWISTORR 305-IC ISO160K 485P WATER COOLING
X3513-64023	TWISTORR 305-IC CFF8 485P WATER COOLING
X3513-64024	TWISTORR 305-IC ISO100K 232AGI AIR COOLING
X3513-64025	TWISTORR 305-IC CFF6 232AGI AIR COOLING
X3513-64026	TWISTORR 305-IC ISO160K 232AGI AIR COOLING
X3513-64027	TWISTORR 305-IC CFF8 232AGI AIR COOLING
X3513-64028	TWISTORR 305-IC ISO100K 232AGI WATER COOLING
X3513-64029	TWISTORR 305-IC CFF6 232AGI WATER COOLING
X3513-64030	TWISTORR 305-IC ISO160K 232AGI WATER COOLING
X3513-64031	TWISTORR 305-IC CFF8 232AGI WATER COOLING

The following figures shows the 24 models.  
The optional air cooling fan is shown in the drawings.

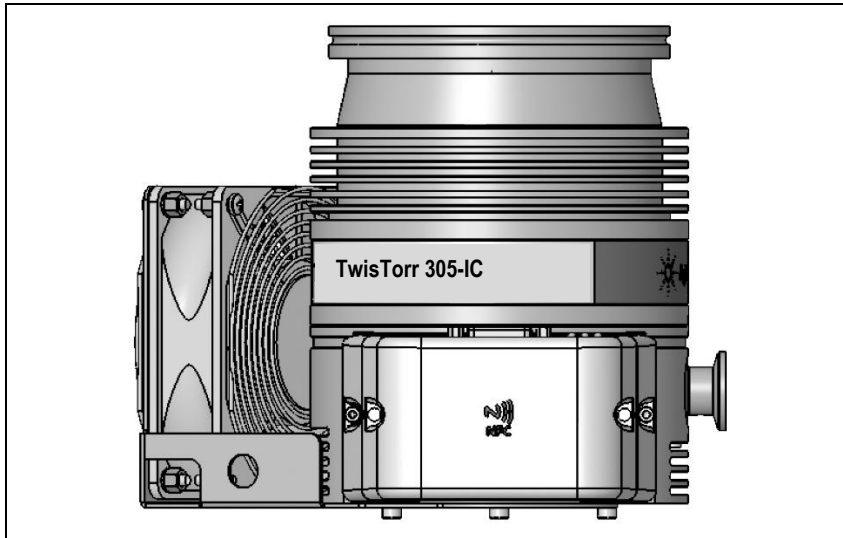

**Figure 5** Model X3513-64000, X3513-64016, X3513-64024

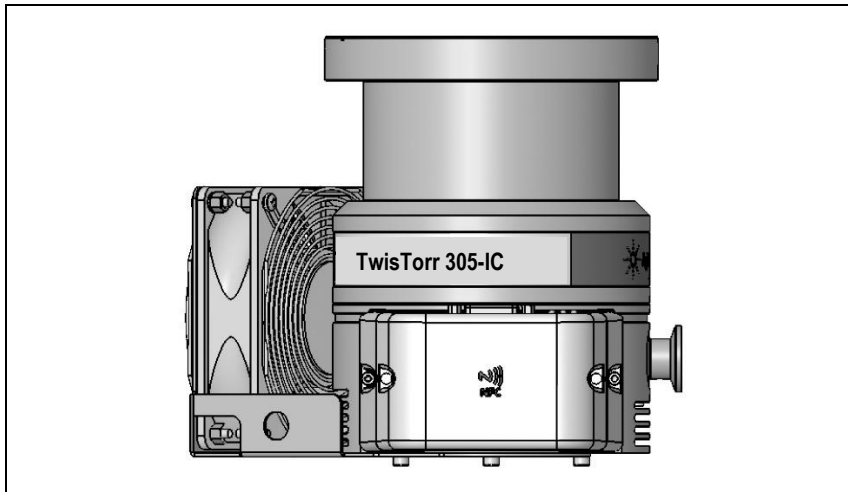

**Figure 6** Model X3513-64001, X3513-64017, X3513-64025

## 8 Technical Information

### Description of the TwisTorr 305-IC

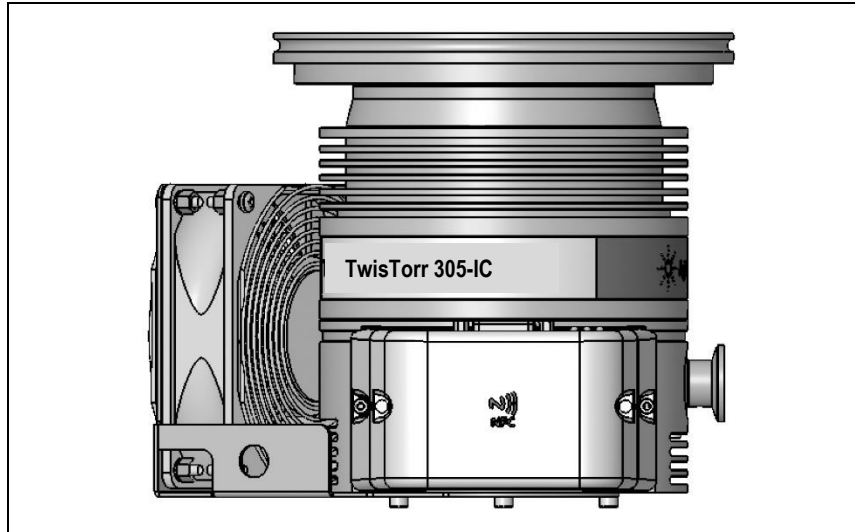

**Figure 7** Model X3513-64002, X3513-64018, X3513-64026

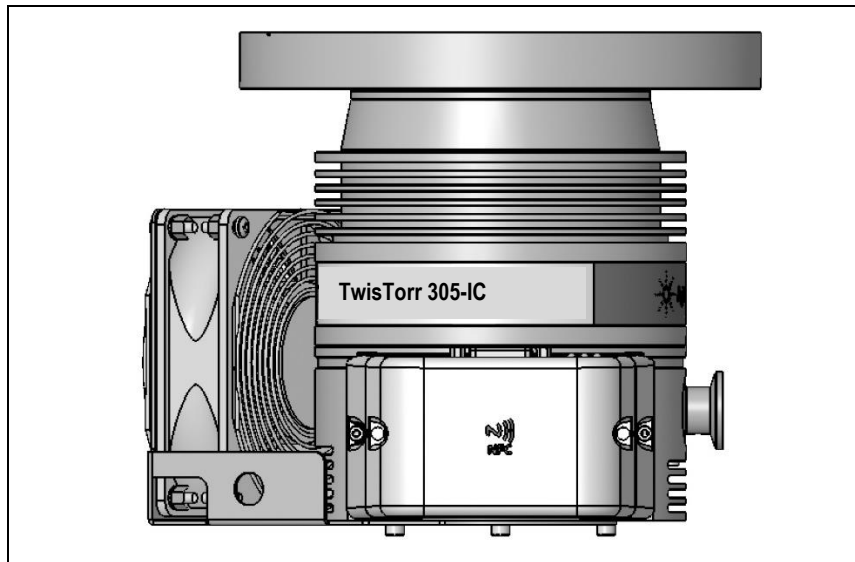

**Figure 8** Model X3513-64003, X3513-64019, X3513-64027

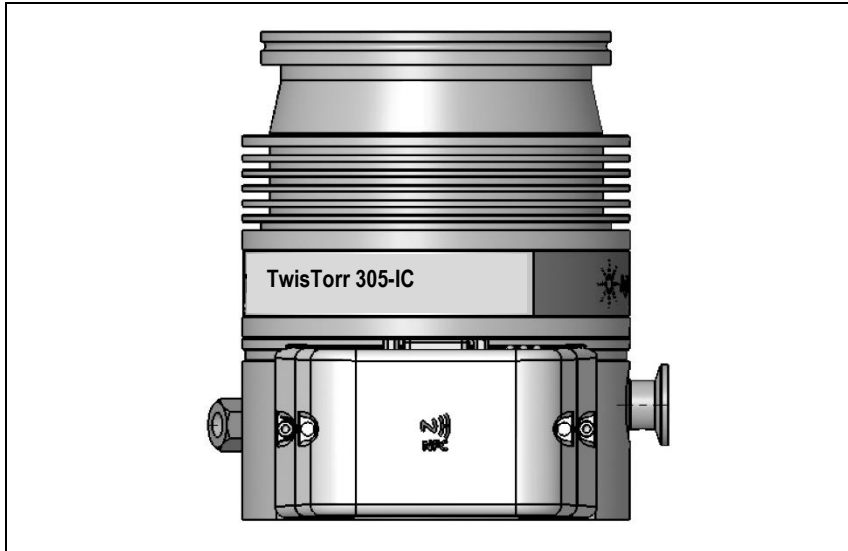

**Figure 9** Model X3513-64004, X3513-64020, X3513-64028

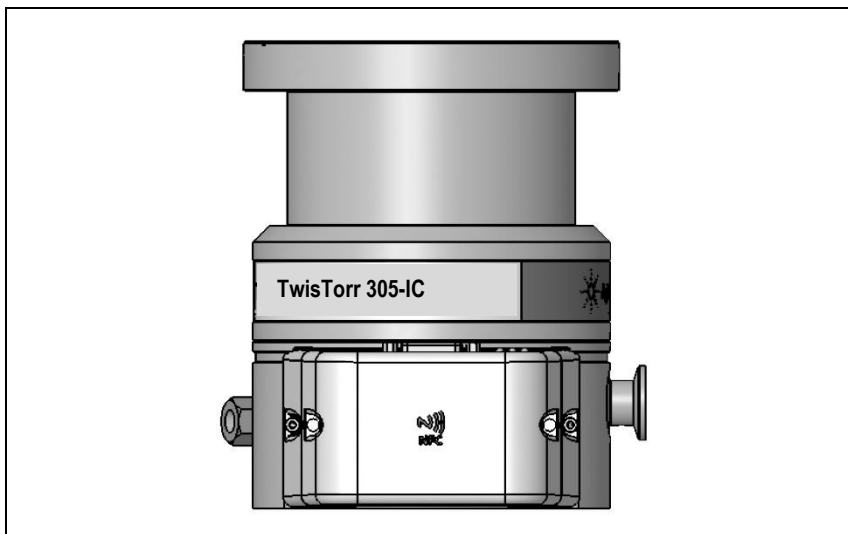

**Figure 10** Model X3513-64005, X3513-64021, X3513-64029

## 8 Technical Information

### Description of the TwisTorr 305-IC

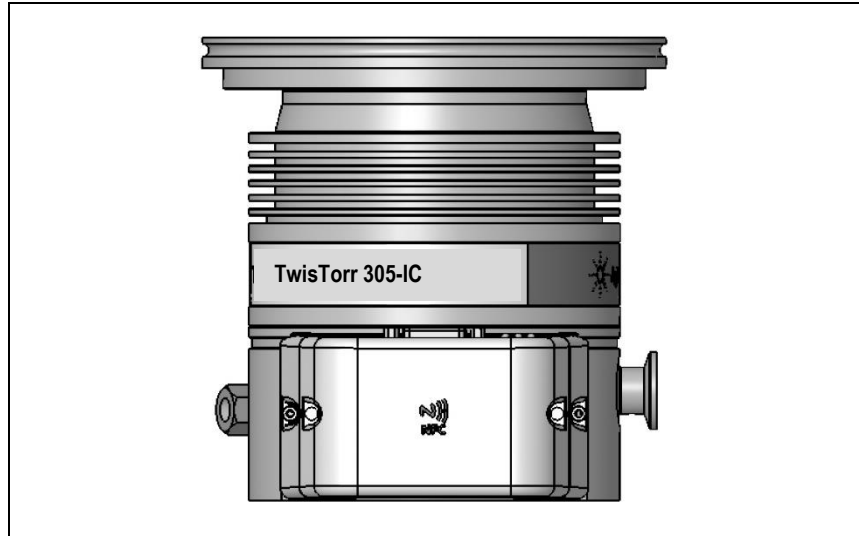

**Figure 11** Model X3513-64006, X3513-64022, X3513-64030

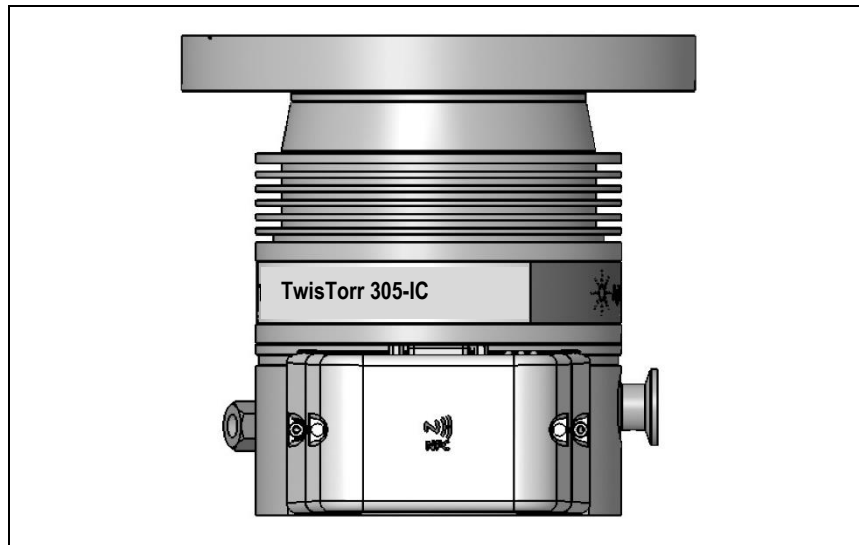

**Figure 12** Model X3513-64007, X3513-64023, X3513-64031

# Technical Specification

**Tab. 1** Technical Specification

Pumping speed	ISO 100/ CF 6" / ISO 160 / CF 8"
N <sub>2</sub>	250 l/s
He	255 l/s
H <sub>2</sub>	220 l/s
Ar	250 l/s
Max gas flow rate (N <sub>2</sub> ):	250 sccm
<b>Note:</b> value refer to water-cooling pump version with:	
<ul style="list-style-type: none"> <li>• water temperature between 15°C and 20°C (non condensing, refer to Figure 13)</li> <li>• backing pump with pumping speed equal or above 5 m<sup>3</sup>/h)</li> </ul>	
Compression ratio	
N <sub>2</sub>	$>1 \times 10^{11}$
He	$>1 \times 10^8$
H <sub>2</sub>	$1.5 \times 10^6$
Ar	$> 1 \times 10^{11}$
Max foreline pressure tolerance N <sub>2</sub>	12 (mbar)
<b>Note:</b> foreline Tolerance defined as the pressure at which the turbopump still produces a compression of 100. For continuous operation, water cooling is recommended (water temperature between 15°C and 20°C).	
Base pressure with recommended forepump	$< 1 \times 10^{-10}$ mbar ( $< 1 \times 10^{-10}$ Torr) (According to standard DIN 28 428, the base pressure is that measured in a leak-free test dome, 48 hours after the completion of test dome bake-out, with a Turbopump fitted with a ConFlat flange and using the recommended pre-vacuum pump)
Inlet flange	CFF 8" O.D.ISO 160 CFF 6" O.D.ISO 100
Foreline flange	KF16 NW (KF25 – optional)
Max Rotation Speed	60600 rpm (1010 Hz driving frequency)
Start-up time	< 3 minutes (it can be longer in case of soft start active)
Recommended forepump	Mechanical pump: DS102, DS302 Dry Pump IDP-3 (no gas flow), IDP-7, IDP10
Operating position	Any

## 8 Technical Information

### Technical Specification

Operating ambient temperature	+5 °C to +35 °C
Relative humidity of air	From graph in Figure 13 (non condensing) **
Bakeout temperature	ISO flange: 75°C at inlet flange max CFF flange: 100°C at inlet flange max <b>Note:</b> Measure a point close to the sealing element.
Lubricant	Permanent lubrication
Air cooling requirements	Natural convection (only with no gas load) Forced air (5- 35 °C ambient temperature)
Coolant water	Minimum flow: 50 l/h (0.22 GPM) Temperature: +15 °C to +30 °C Max pressure: 5 bar (75 psi)
Noise Pressure level	41 dB(A) at 1 meter
<b>Note:</b> mean values based on a significative sample (Ar and N2 compression ratio estimated); standard deviation per test: pumping speed: below $\pm 7\%$ ; noise pressure level: $\pm 10\%$ (only pump).	
Installation category	II
Pollution degree	2
Storage temperature	-40° C to +70° C
Weight kg (lbs): (*)	
Pump ISO 100 K	ISO 100 K 5.74 (12.65)
Pump CFF 6''	CFF 6" 8.06 (17.76)
Pump ISO 160 K	ISO 160 K 6.18 (13.62)
Pump CFF 8''	CFF 8" 10.33 (22.77)
<b>Note:</b> versions with water cooling kit	
Pwr supply (24 Vdc):	
Input voltage:	24 Vdc
Max input pwr:	200 W
Pump stand-by average pwr:	10 W - 15 W
Pump max oper. pwr:	150 W with water or air cooling In case the user does not have a 24Vdc power output already available, the power supply MFR: MeanWell; MPN: NDR-240-24 is suitable for the application.
Protection fuse	8 A
Max operating altitude	3000 m

Compliance with: EN 61010-1  
 EN 61326-1  
 EN 1012-2  
 EN 12100  
 EN 50581  
 Machinery Directive 2006/42/EC  
 Electromagnetic Compatibility Directive 2014/30/EU  
 Directive 2011/65/EU

Power cable Admitted power supply is 24V +/- 10%; please dimension the power cables taking into account to always guarantee the minimum voltage level. I.e. for AWG 20 resistance is 33,31 mOhm/m; so for a cable of 6 meters and maximum current (7.5A) the voltage lost is 1.5V.

USB communication as per USB 1.0

**NOTE**

When the TwisTorr 305-IC has been stored at a temperature less than 5°C, wait until the system has reached the above mentioned temperature before switch the TwisTorr 305-IC on.

\*\*

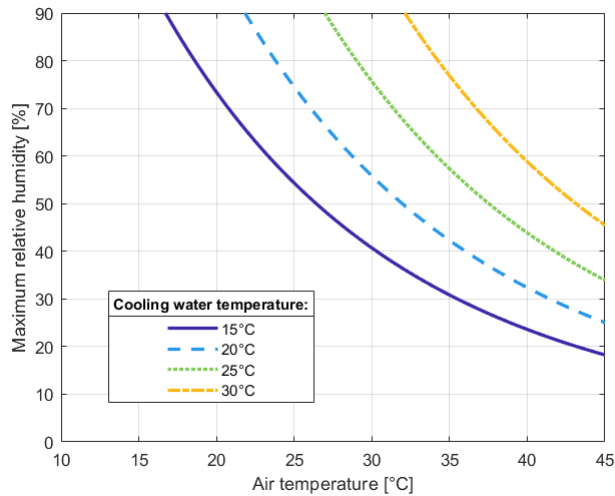

**Figure 13** Maximum allowed relative humidity as a function of the air temperature for each cooling-water temperature

## TwisTorr 305-IC Outline

The following figures show the TwisTorr 305-IC (dimensions are in mm [inches]).

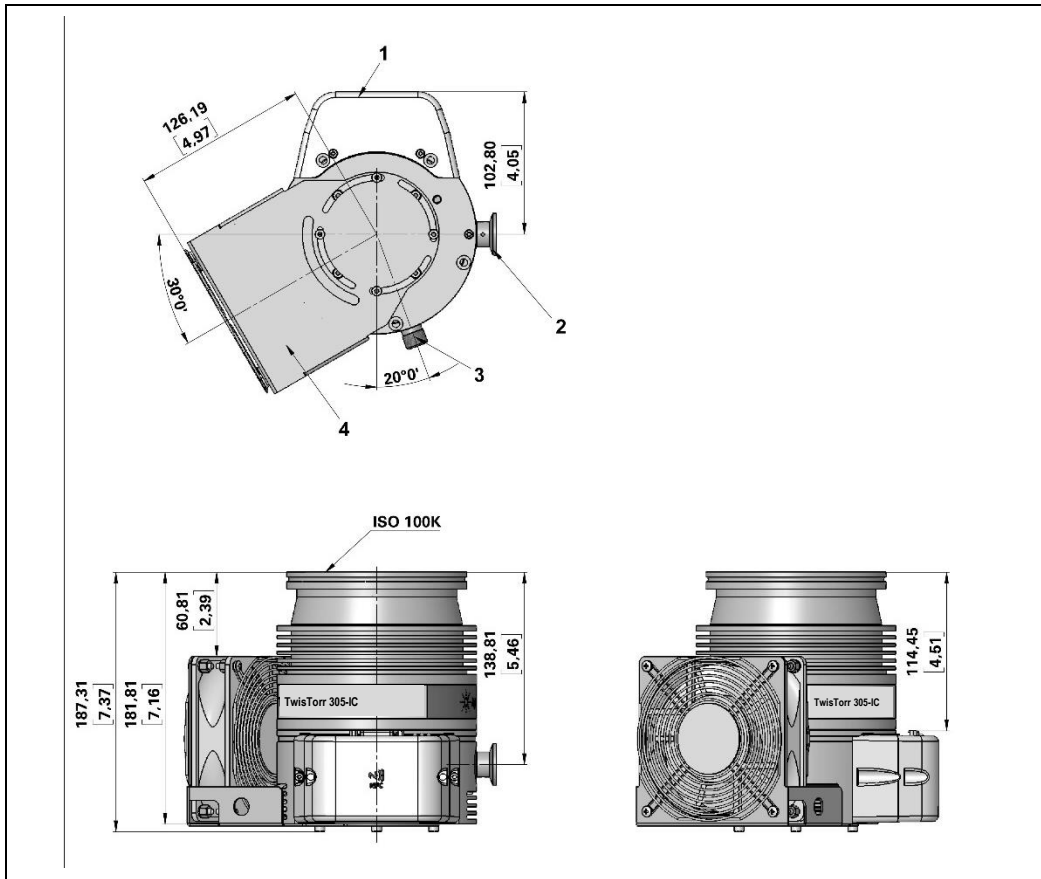

**Figure 14** TwisTorr 305-IC ISO 100 (X3513-64000, X3513-64016, X3513-64024), + AIR COOLING KIT

- 1 On board CNTR;
- 2 Foreline flange KF16
- 3 VENT screw
- 4 FAN

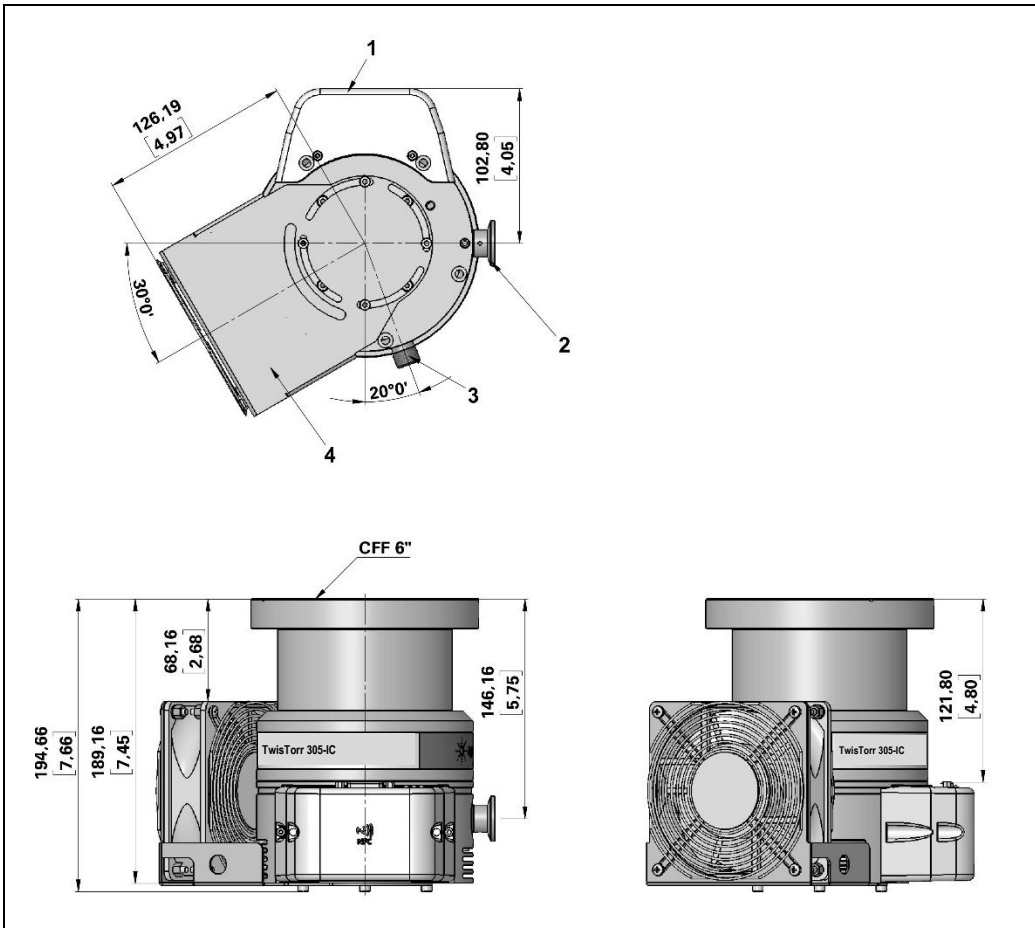

**Figure 15** TwisTorr 305-IC CFF6, (X3513-64001, X3513-64017, X3513-64025), + AIR COOLING KIT

- 1 On board CNTR;
- 2 Foreline flange KF16
- 3 VENT screw
- 4 FAN

**8 Technical Information**  
**TwisTorr 305-IC Outline**

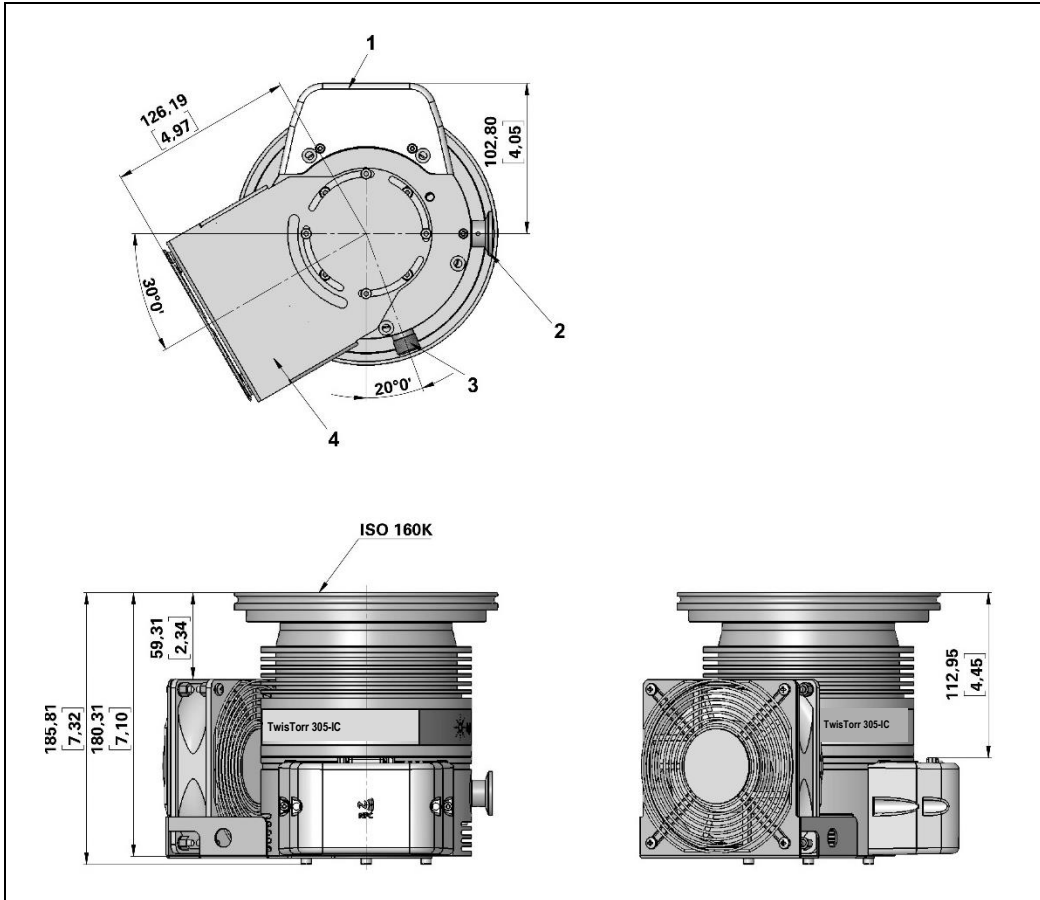

**Figure 16** TwisTorr 305-IC ISO 160K (X3513-64002, X3513-64018, X3513-64026) + AIR COOLING KIT

- 1 On board CNTR;
- 2 Foreline flange KF16
- 3 VENT screw
- 4 FAN

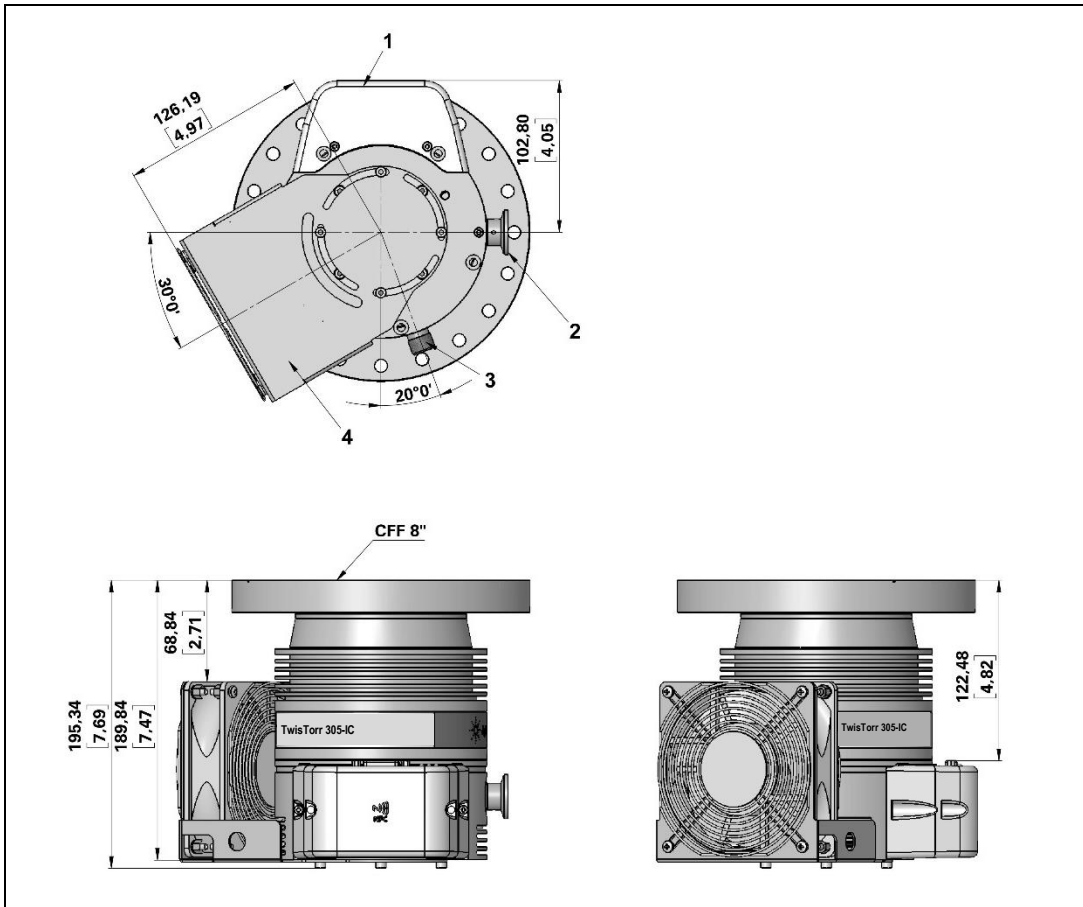

**Figure 17** TwisTorr 305-IC CFF8 (X3513-64003, X3513-64019, X3513-64027) + AIR COOLING KIT

- 1 On board CNTR;
- 2 Foreline flange KF16
- 3 VENT screw
- 4 FAN

**8 Technical Information**  
**TwisTorr 305-IC Outline**

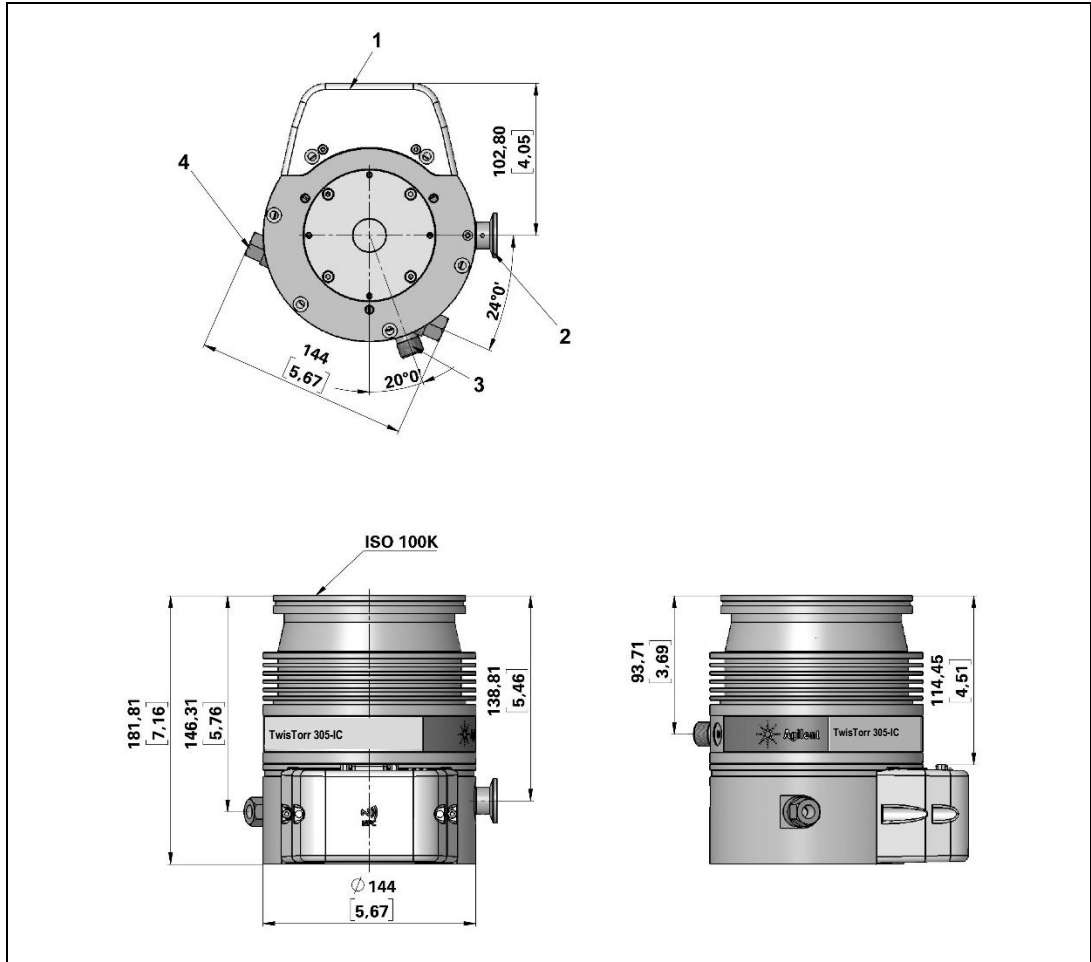

**Figure 18** TwisTorr 305-IC ISO 100K (X3513-64004, X3513-64020, X3513-64028)

- 1 On board CNTR;
- 2 Foreline flange KF16
- 3 VENT screw
- 4 FAN

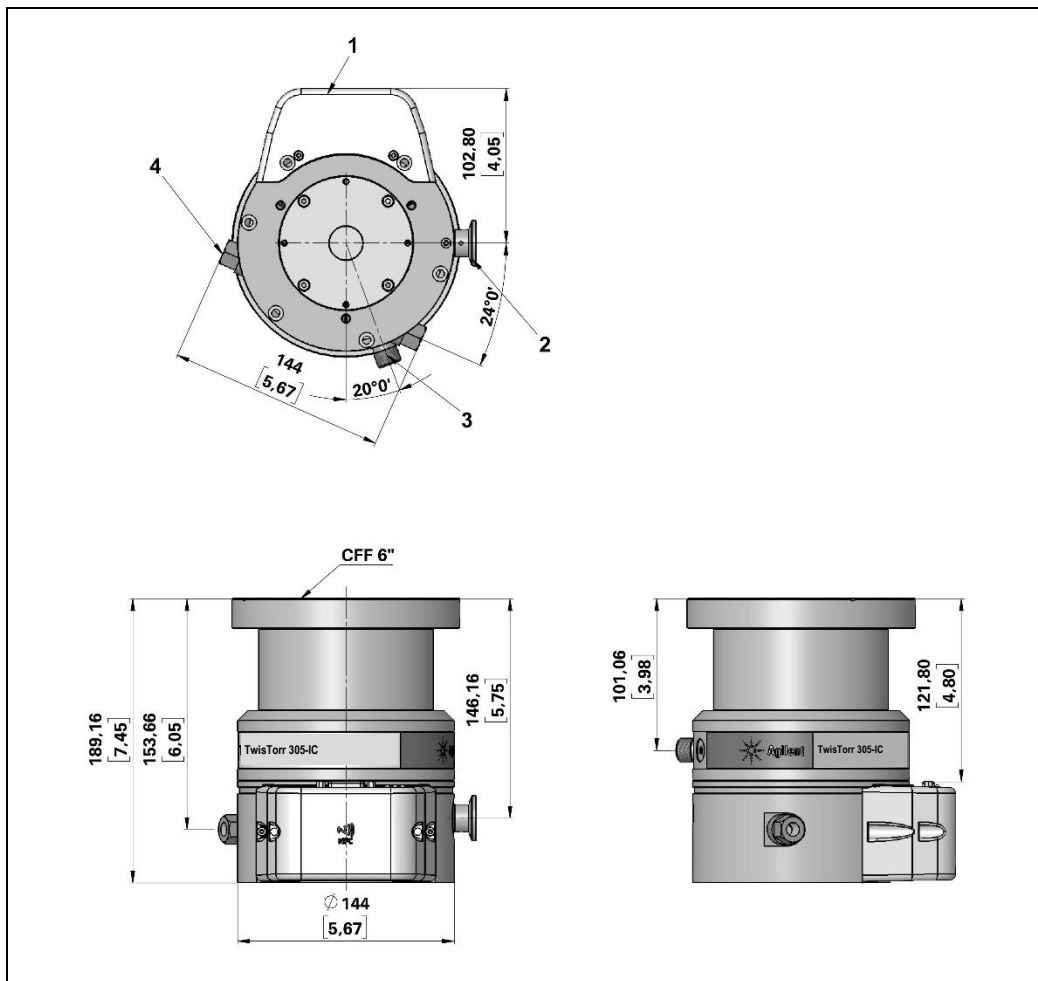
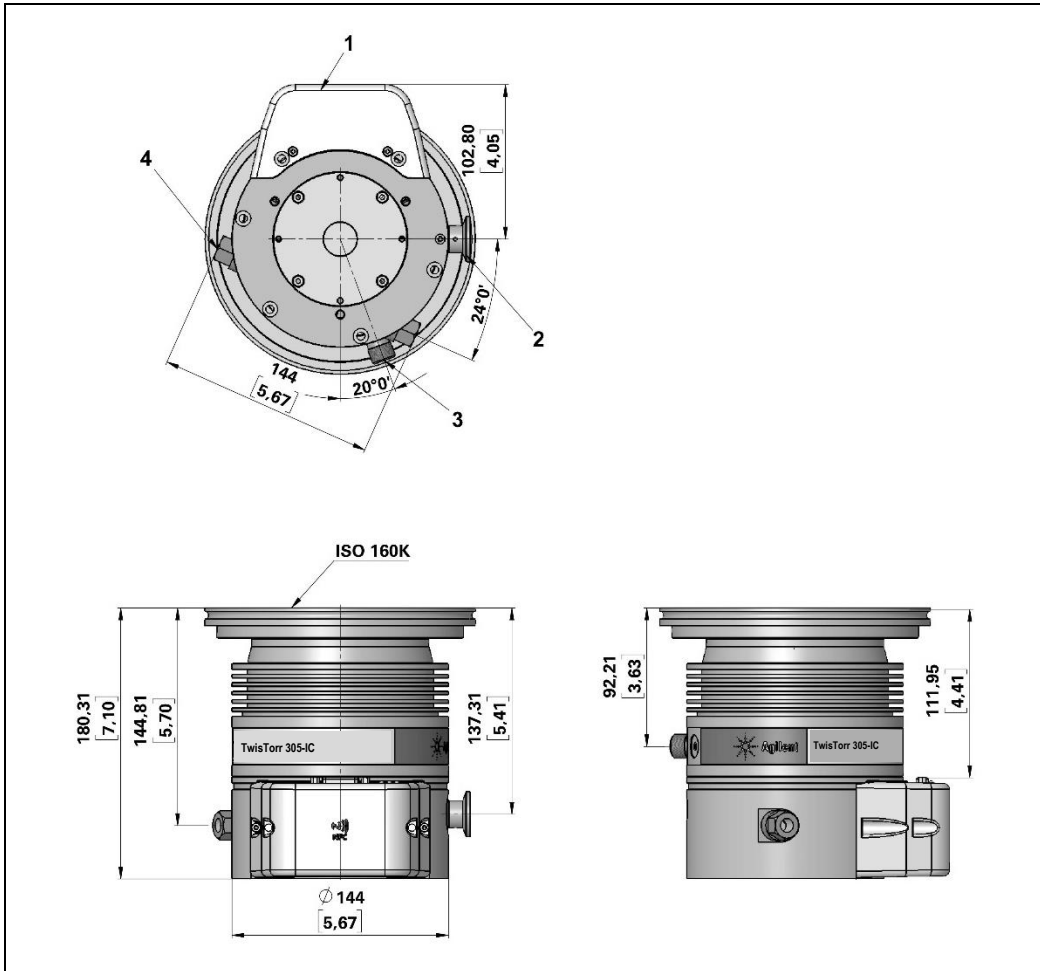

Figure 19 TwisTorr 305-IC + CFF6 (X3513-64005, X3513-64021, X3513-64029)

- 1 On board CNTR;
- 2 Foreline flange KF16
- 3 VENT screw
- 4 Water cooling

**8 Technical Information**  
**TwisTorr 305-IC Outline**



**Figure 20** TwisTorr 305-IC ISO 160K (X3513-64006, X3513-64022, X3513-64030)

- 1 On board CNTR;
- 2 Foreline flange KF16
- 3 VENT screw
- 4 Water cooling

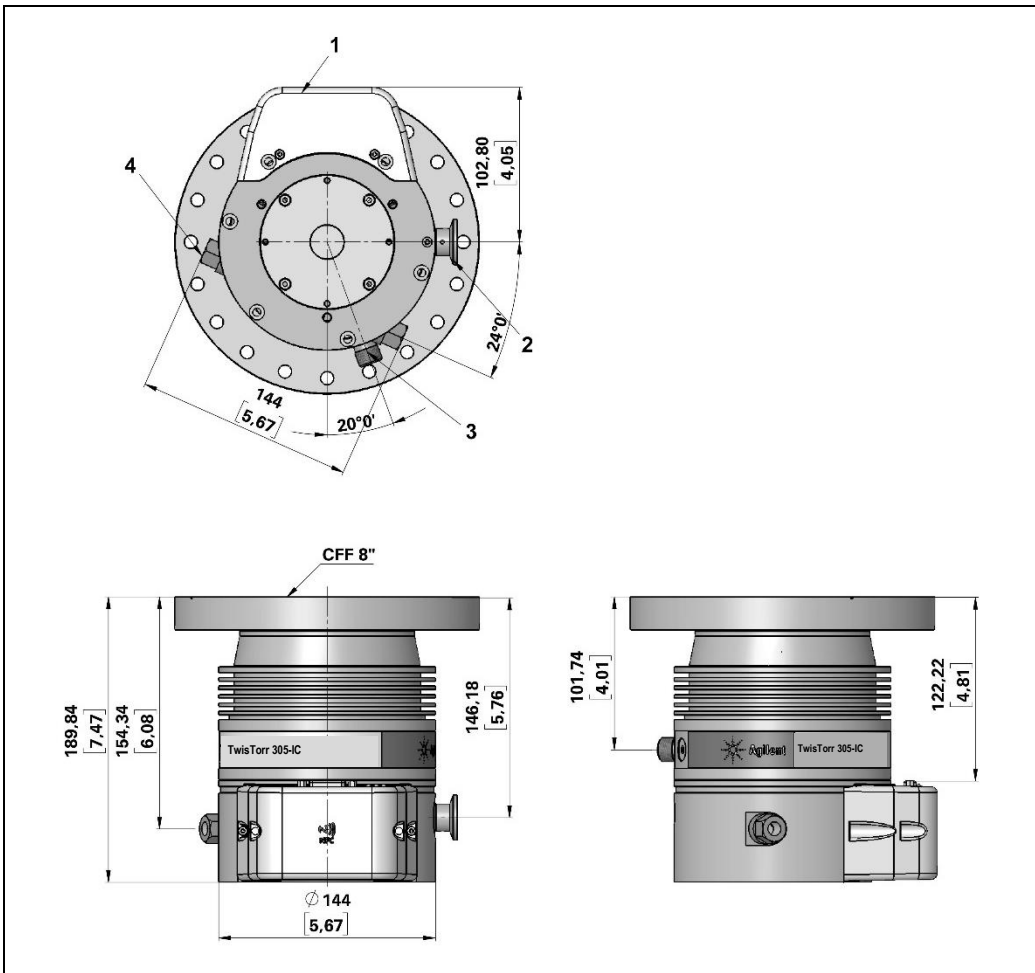
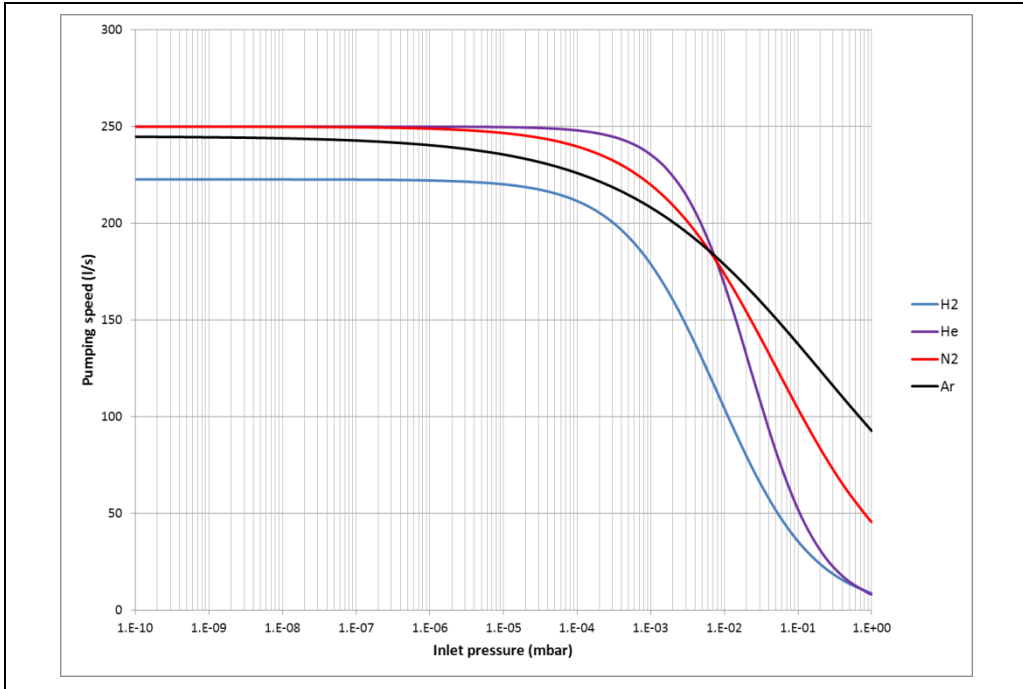

**Figure 21** TwisTorr 305-IC + CFF8 (X3513-64007, X3513-64023, X3513-64031)

- 1 On board CNTR;
- 2 Foreline flange KF16
- 3 VENT screw
- 4 Water cooling

## 8 Technical Information

### TwisTorr 305-IC Outline



**Figure 22** Graph of Pumping Speed vs. Inlet Pressure for TwisTorr 305-IC pump

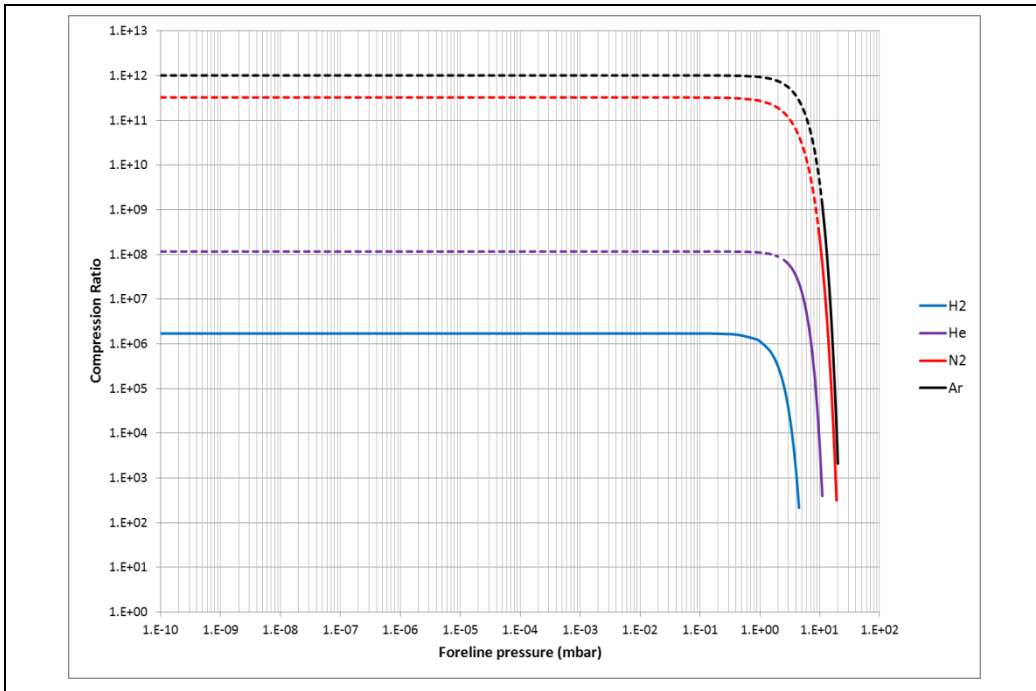
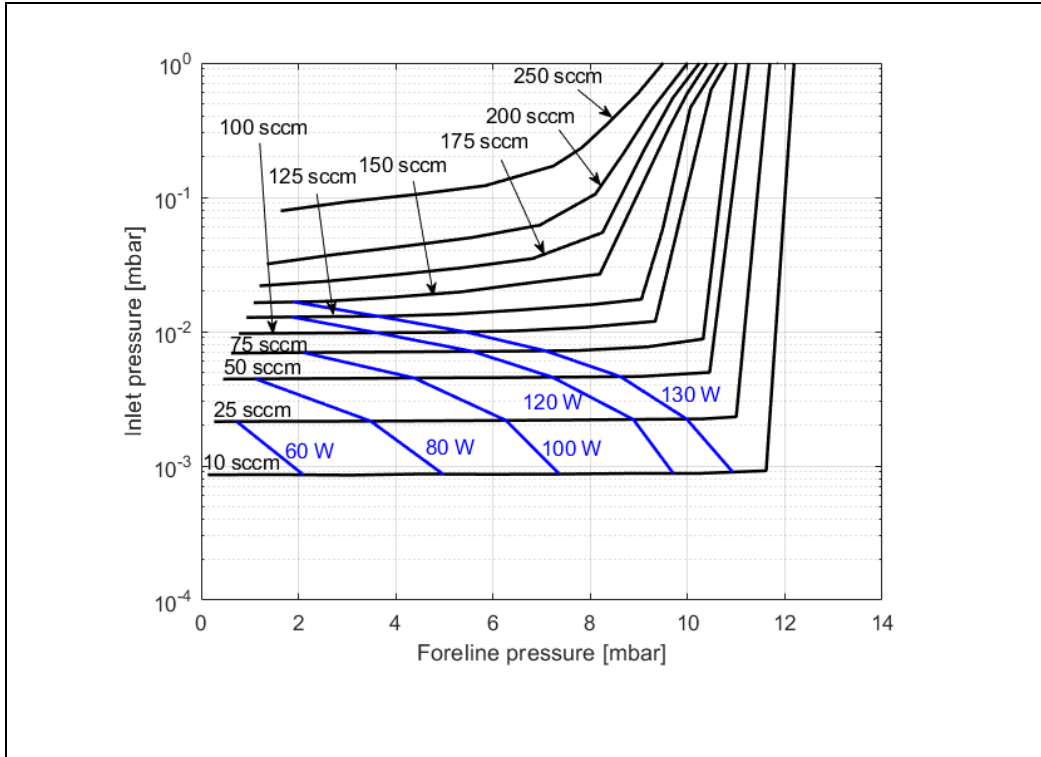

Figure 23 Graph of Compression ratio vs. Foreline Pressure for TwisTorr 305-IC pump

**8 Technical Information**  
TwisTorr 305-IC Outline



**Figure 24** Graph of Iso Flow-Iso Power for TwisTorr 305-IC with Nitrogen gas (water cooling version with water temperature in range 15°C-20°C, backing pump 11.6 m<sup>3</sup>/h)

## Pump Operations

### Inlet screen installation

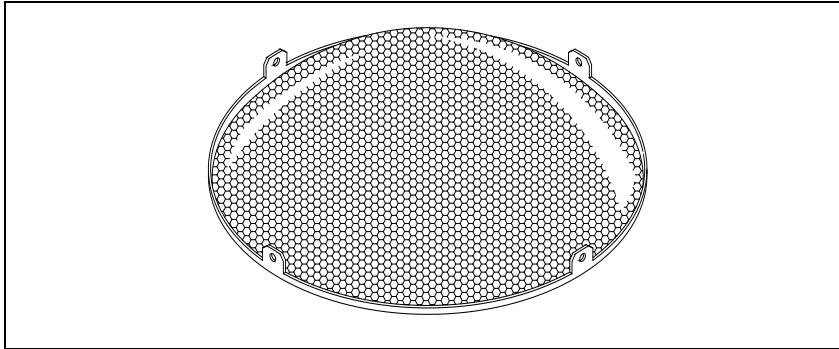

**Figure 25** Model 9699302 and 9699304

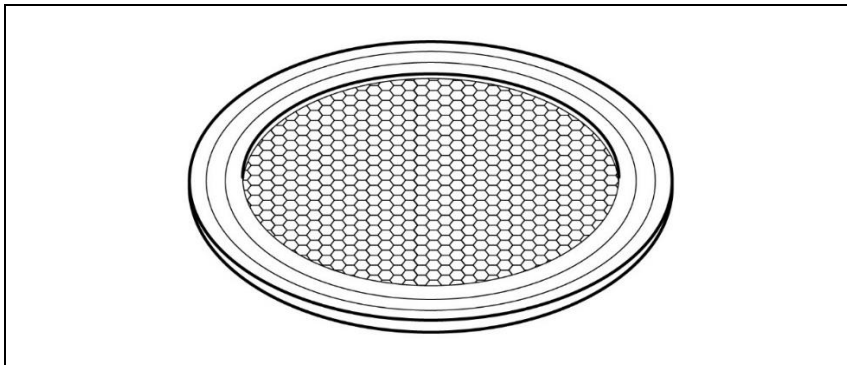

**Figure 26** Model X3500-68000 and X3500-68001

Inlet screens help prevent damage to the blades by preventing foreign objects from entering the pump. The following part numbers belong to the corresponding flange:

- 9699302 (CFF 6")
- 9699304 (CFF 8")
- X3500-68000 (ISO 100)
- X3500-68001 (ISO 160)

## 8 Technical Information

### Pump Operations

Installing an inlet screen will reduce the pumping speed by the following amount:

Reduction in pumping speed (%)				
	Ar	N <sub>2</sub>	He	H <sub>2</sub>
X3500-68000	20%	18%	7%	5%
X3500-68001	20%	18%	7%	5%

The inlet screen is fitted in the upper part of the pump, as shown in the figure.

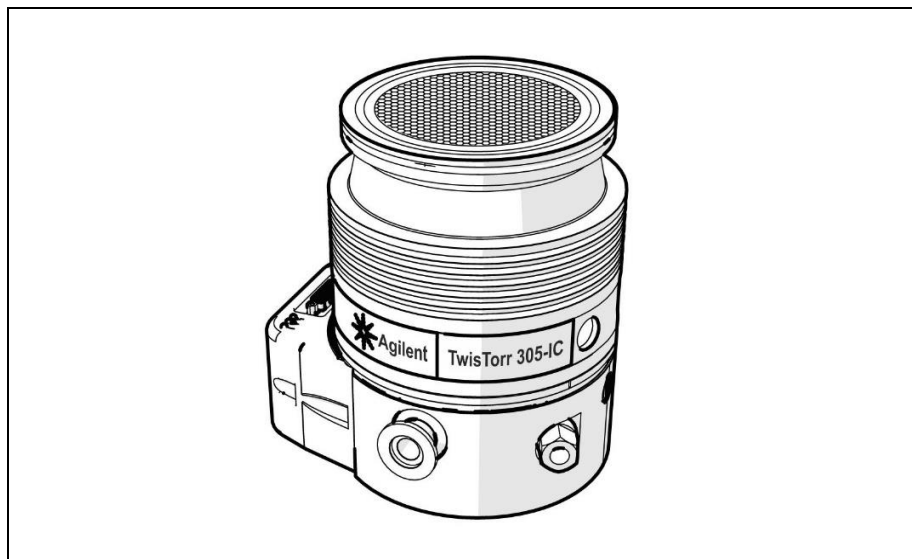

**Figure 27**

The screen can be mounted on each pump.

The screen can be removed as shown in the following figure.

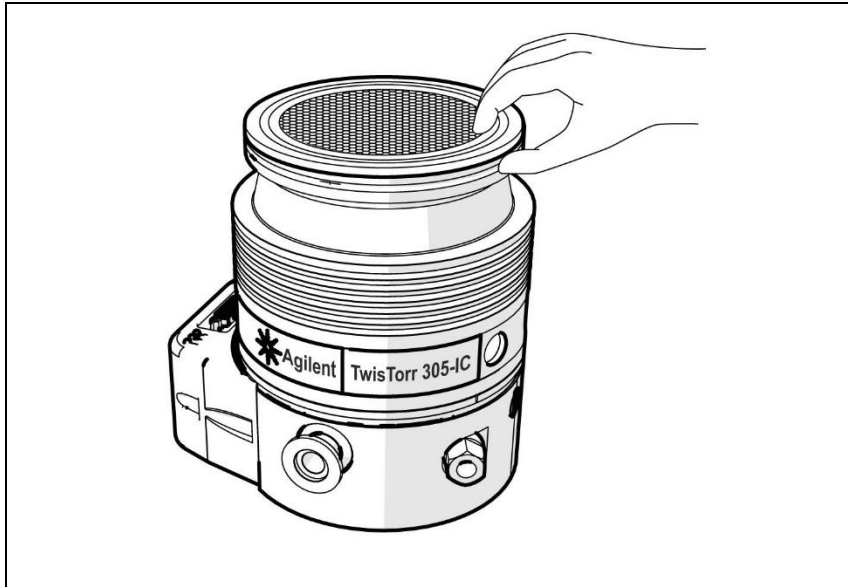

**Figure 28**

The overall flange dimensions with the protection screen fitted on pump do not change as the inlet screen remains integrated into the center-ring.

## 8 Technical Information

### Air Cooling Kit Installation (only for air cooled pumps)

# Air Cooling Kit Installation (only for air cooled pumps)

An air cooling kit (X3500-68010) is available to improve the TwisTorr 305-IC cooling during operational conditions.

Fan specifications:

- air flow: 147 m<sup>3</sup>/h
- input voltage: 24 Vdc
- dimensions: 119 x 119 x 32 mm (4.7 x 4.7 x 1.3 in.)
- power: 2.6 W
- 

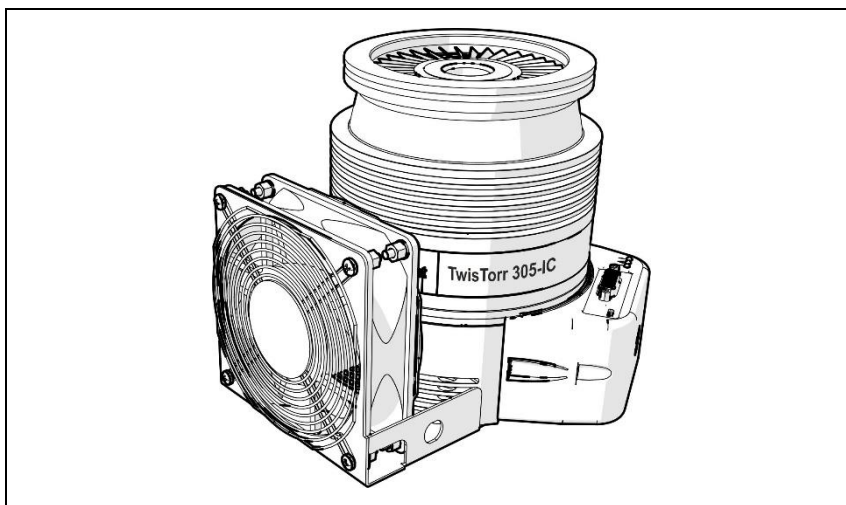

**Figure 29**

The fan bracket is shaped so that it can be mounted close to the pump.

To fix the fan to the TwisTorr 305-IC case execute the following procedure (see the following figure):

- 1 Mount the 305-IC Fan/Vent Adapter kit P/N X3514-68001 (the adapter is provided with two extension cables, suitable for mounting of the cooling fan and the vent kit).
- 2 Fix the fan to the suitable bracket by means of the furnished screws
- 3 Fix the bracket to the pump body.
- 4 Connect the fan supply to the the adapter (P/N X3514-68001) connector, by the extension cable.

## Assembling procedure Air Cooling Kit X3500-68010

To mount the air cooling Kit on the TwisTorr 305-IC pump, proceed as follows:

- 1 Fix the fan (1) to the bracket (2) using the furnished screws (3).

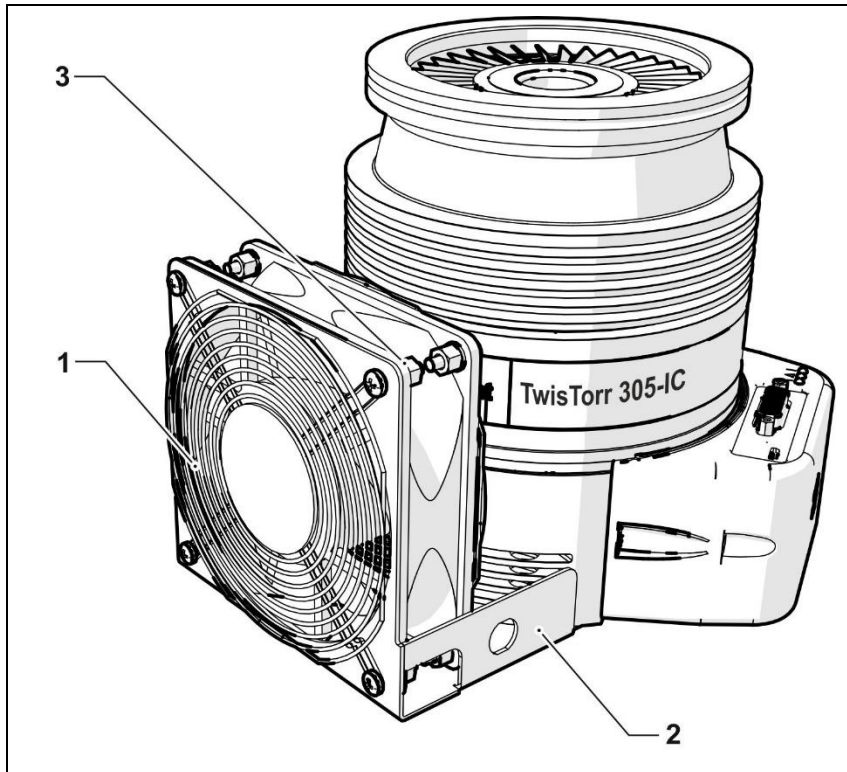

**Figure 30** Mounting the fan on the bracket

## 8 Technical Information

### Assembling procedure Air Cooling Kit X3500-68010

- 2 Now fix the air cooling bracket/fan assembly to the pump body.

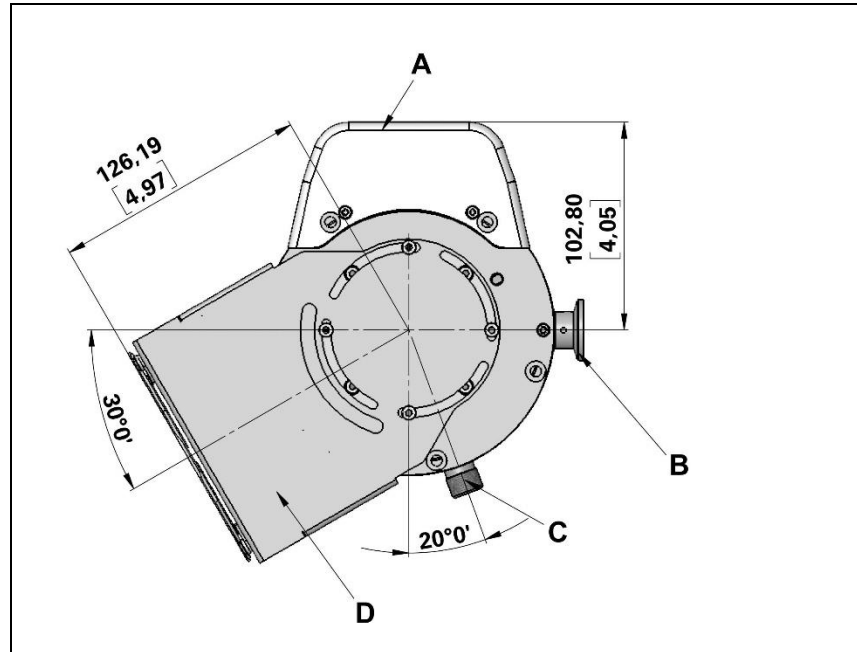
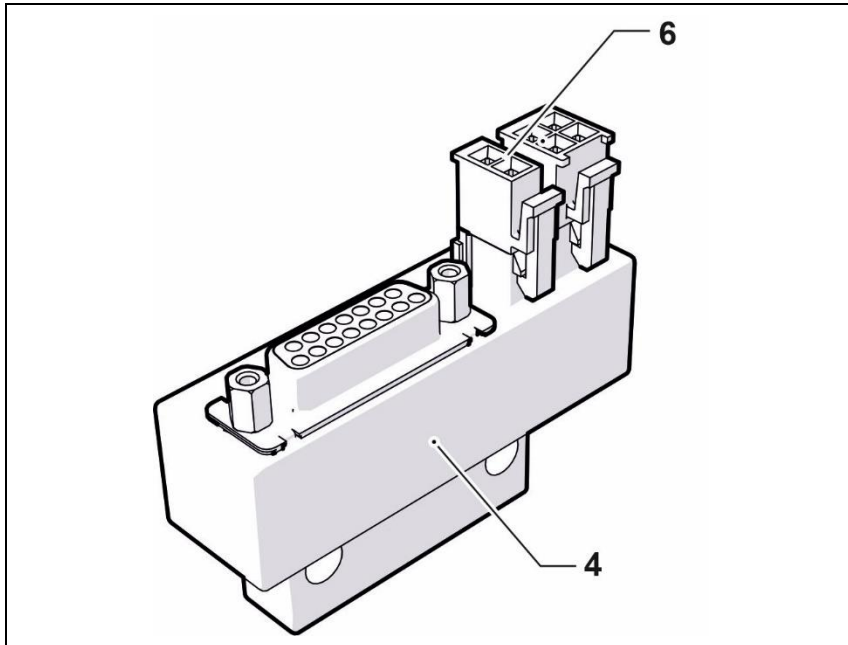

Figure 31

- A On board CNTR
- B Foreline flange KF16
- C VENT screw
- D Fan

- 3** To power the air cooling kit, mount the adapter (4) on the connector DB15 (5) (see figure on the next page) of the pump and then connect the air cooling kit connector to the adapter connector (6), by the way of the extension cable which is provided to together with the adapter P/N X3514-68001.



**Figure 32** Overview of TwisTorr 305-IC adapter

## 8 Technical Information

### Assembling procedure Air Cooling Kit X3500-68010

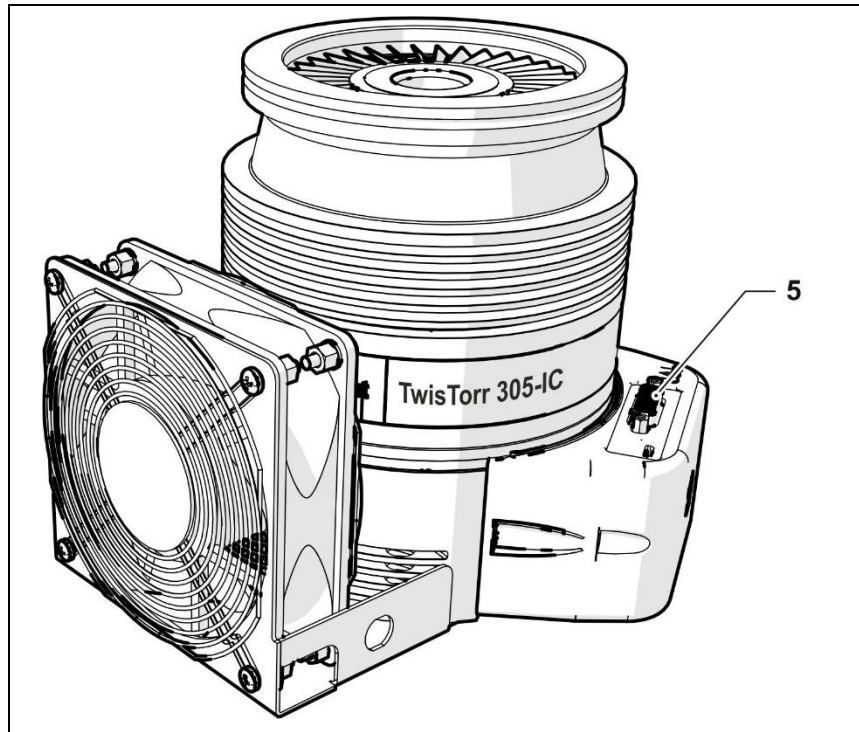

**Figure 33** Connector DB15 (item 5) on pump edge

The picture shows the pump with the optional cooling fan.

## Water Cooling Kit Connection (only for water cooling pumps)

Two types of water cooling kits are available to be mounted when the pump is used under heavy load conditions or when air cooling is insufficient.

The two model part numbers are: 9699337 (metallic model), and 9699347 (plastic model).

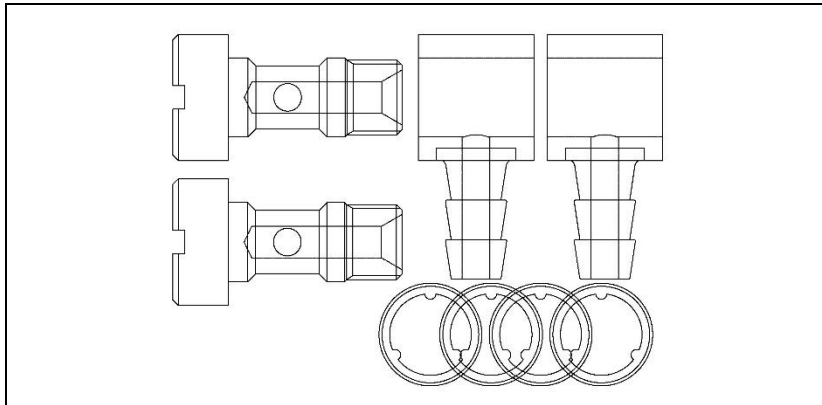

**Figure 34** Model 9699337

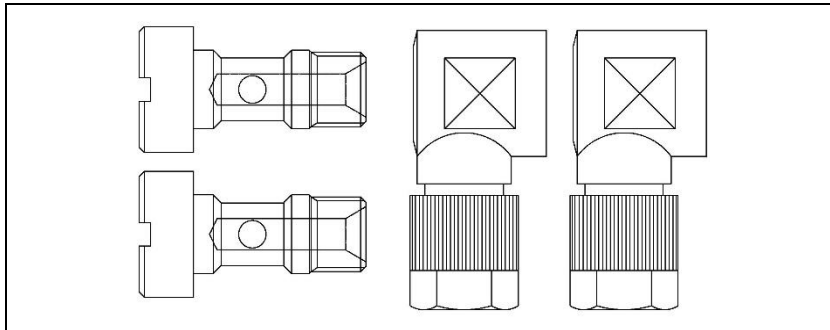

**Figure 35** Model 9699347

## 8 Technical Information

### Water Cooling Kit Connection (only for water cooling pumps)

#### CAUTION!

The items of the plastic model kit must be assembled as shown in the following figure.

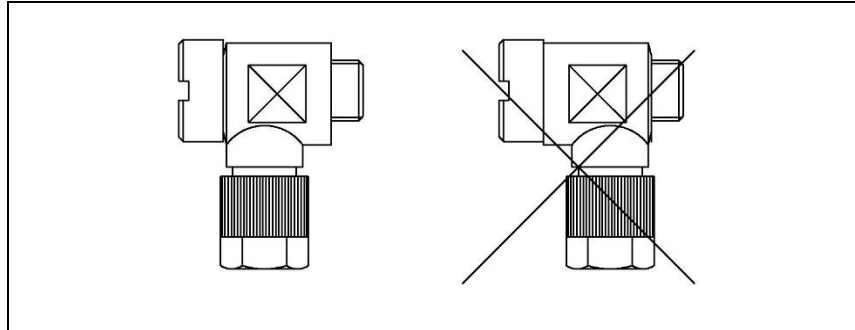

Figure 36

The assembled kit must be screwed into the suitable holes of the pump body with a recommended torque of 5 Nm.

The metallic model is assembled as shown in the following figure.

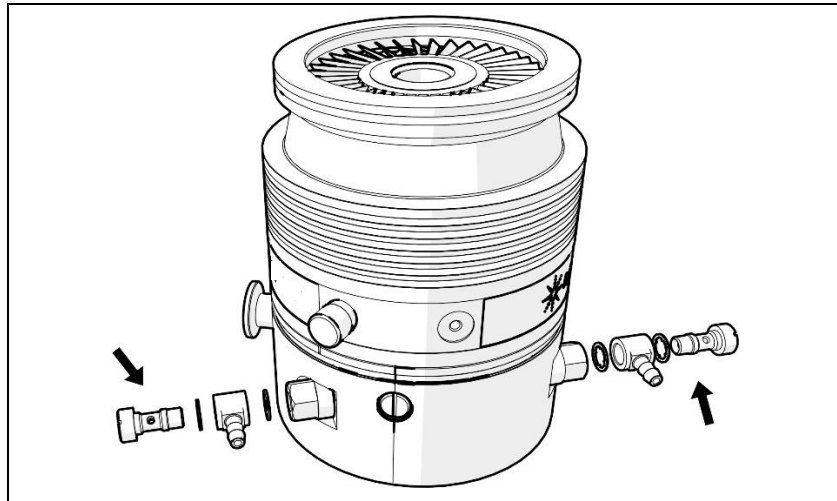

Figure 37

Two 6 mm (1/4") internal diameter rubber or plastic hoses from the water supply must be fitted to the two nozzles.

**NOTE**

These hoses must be held on the respective nozzles using clamps to avoid the tubes from becoming loose or disconnected during operation.

---

Cooling may be carried out either through an open circuit with eventual discharge of the water, or using a closed circuit cooling system.

The water temperature must be between +15 °C and +30 °C with a flow rate higher than 50 l/h (0.22 GPM). The max water inlet pressure must be lower than 5 bar.

**NOTE**

The water electrical conductance must be  $\leq 500 \mu\text{s}/\text{cm}$ . When the conductivity is higher, in closed water circuit, the use of up to 20 % of Ethyl-Glycole is recommended.

---

## Vent Accessories

The vent valve and vent device enable an automatic vent operation.

TwisTorr 305-IC compatible Vent Valve mod. 9699834 – 9699834M006

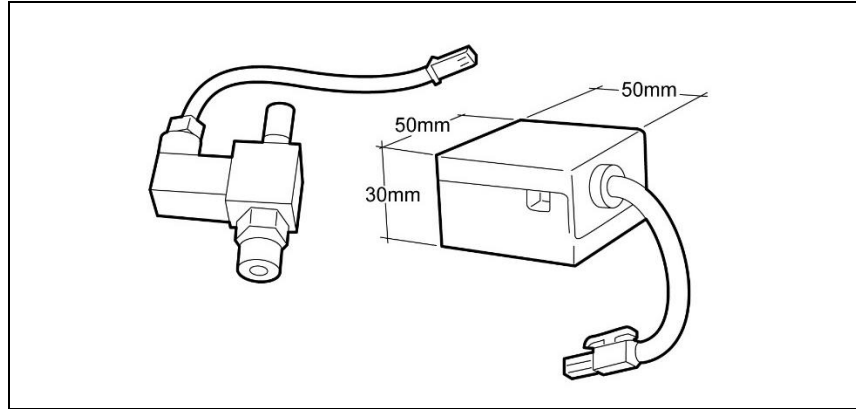

**Figure 38**

This vent valve waits before opening a minimum time of about 5 sec. This time can be increased up to about 220 min. by means of a setting of the controller software (optional).

To install the vent valve, unscrew the threaded plug (see figure below).

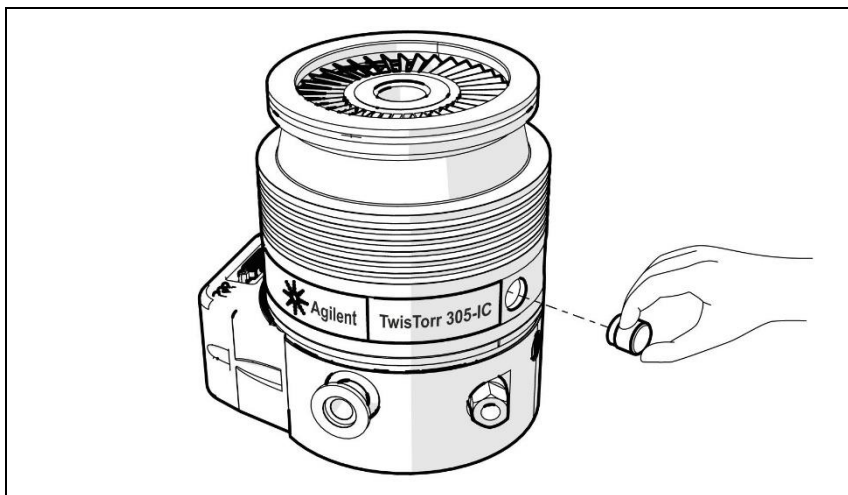

**Figure 39**

Then screw the vent valve into the pump and tighten it using a 16 mm hexagonal spanner with a torque of 2.5 Nm.

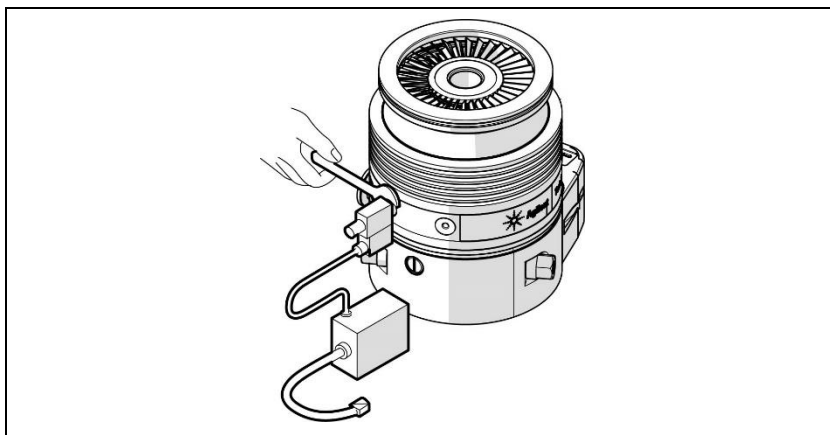

**Figure 40**

## 8 Technical Information

### Vent Accessories

Connect the connector of the kit on the mating connector (1) on the 305-IC Fan/Vent Adapter kit P/N X3514-68001, when the assembly is completed.

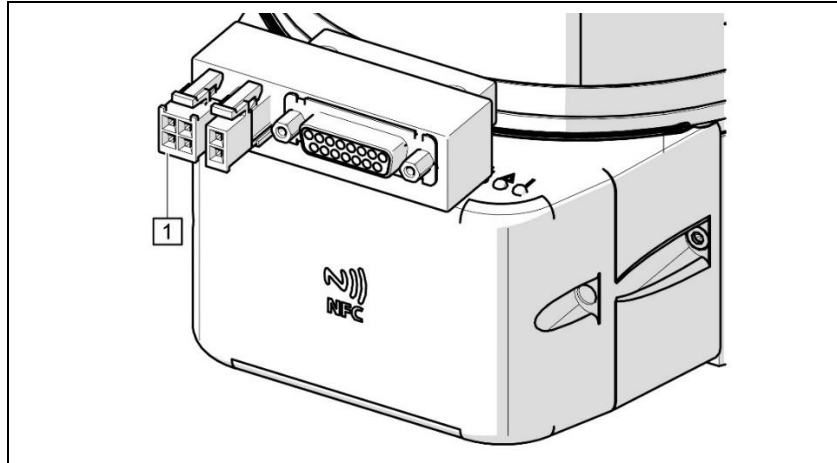

Figure 41

#### CAUTION!

Do not overtighten the valve as this may damage the thread on the pump.

Then connect the cable from the valve to the suitable connector on the controller.

## Pump Used with Corrosive and Oxidizing Gases

To prevent damage to the bearings, an inert gas must flow into the pump body around the upper bearing towards the forevacuum line. To supply the inert purge gas (e. g. nitrogen) to the pump through the purge port, connect a gas purge valve between the pressure regulator and the pump.

Adjust the pressure regulator in order to read a gas flow rate of 0.1 to 0.8 mbar l/s.

### CAUTION!

To prevent bearing damage, Agilent suggests a minimum purge gas flow rate of 10 sccm (0.17 mbar l/s). This value can be exceeded, according to the process requirements. Please contact Agilent for specific applications.

---

When a purge gas is used with the recommended forepump of 15 m<sup>3</sup>/h (8.82 CFM) a high vacuum pressure in the 10<sup>-8</sup> mbar range can be achieved. The recommended gas flow maintains a pressure into the pump body higher than the fore-vacuum pressure. The recommended procedure to vent the system and the pump avoiding the contact between the pump bearings and the corrosive gas is described in the following points:

- 1 Close the corrosive gas flow into the system.
- 2 Leave the Turbo pump and the backing pump running and the purge gas flowing, wait for enough time to evacuate the corrosive gas from the system.
- 3 Turn off the Turbopump and the backing pump.
- 4 Open the Turbo vent port slowly until to reach atmospheric pressure in the system.
- 5 When the Turbo pump and the backing pump are stopped and the system is at atmospheric pressure, for a better bearing protection it is advisable to leave the purge gas flowing into the Turbo pump, with the chamber or the Turbo vent valve open, to avoid system overpressures. If the vent valve can't be kept open, the backing pump should be left operating.

## 8 Technical Information

### Pump Used with Corrosive and Oxidizing Gases

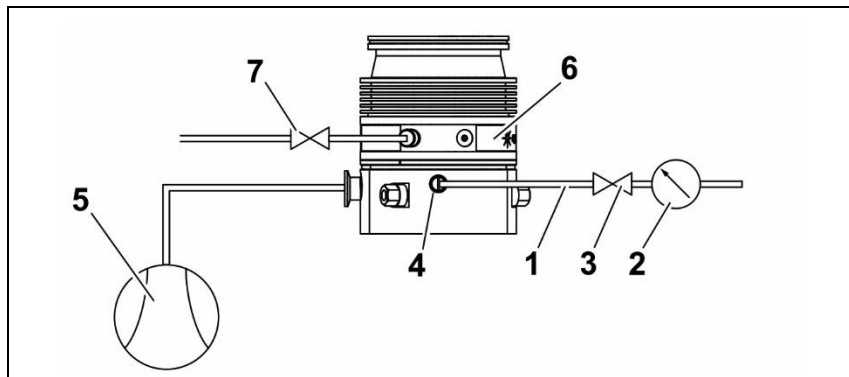
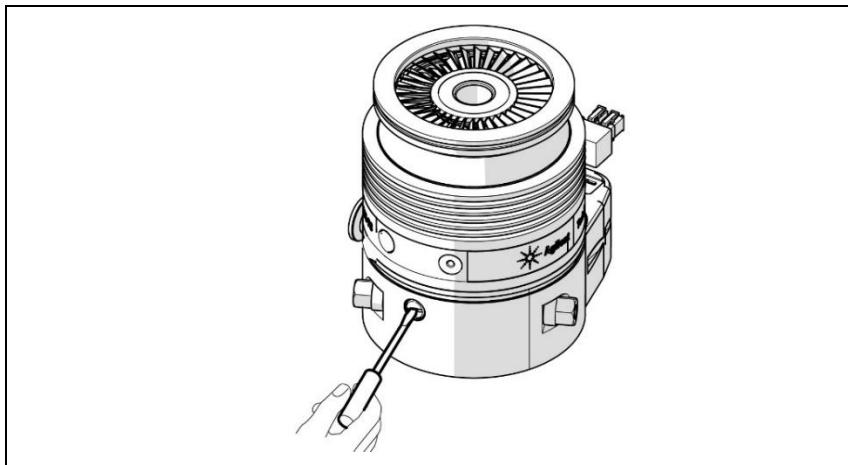

**Figure 42** Purge layout

- 4 Purge gas line
- 5 Pressure regulator
- 6 Gas purge valve
- 7 Gas purge port
- 8 Forevacuum pump
- 9 Turbopump
- 10 Vent valve

## Purge Valve Installation

A gas purge valve is available to protect the pump bearings against particulate and corrosive gases that could move into the pump. To install the gas purge valve it is necessary to switch off the pump and unscrew the purge port cover as shown in the following figure.



**Figure 43**

and then screw the gas purge valve (with a torque of 2.5 Nm) as shown in the following figure.

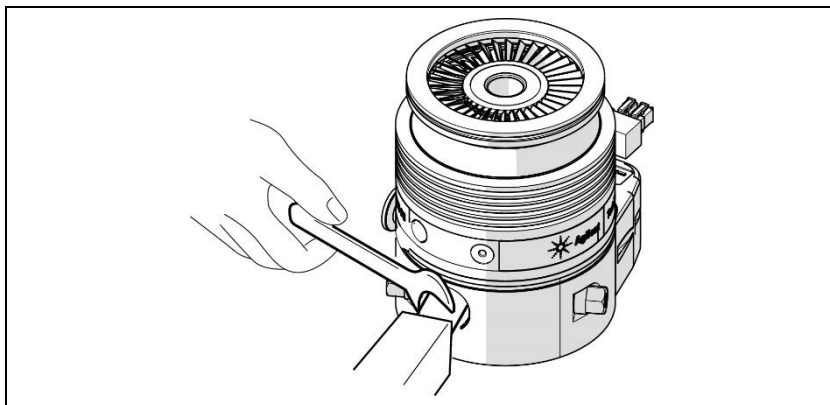

**Figure 44**

## 8 Technical Information

### Pump Used in Presence of Magnetic Fields

## Pump Used in Presence of Magnetic Fields

Function not applicable as there are electronic parts on the pump.

## Vibration Isolator Installation

Four vibration isolators for ISO and CFF inlet flange version pumps are available as accessories. The four model part numbers are the following:

- model 9699344 for ISO 100 flange;
- model 9699345 for ISO 160 flange;
- model 9699334 for CFF 6" flange;
- model 9699335 for CFF 8" flange.

They typically reduce the vibration transmitted from the TwisTorr 305-IC to the system by a factor of 20.

## Controller Operations

### Interconnections

The following figure shows the TwisTorr 305-IC on board interconnections.

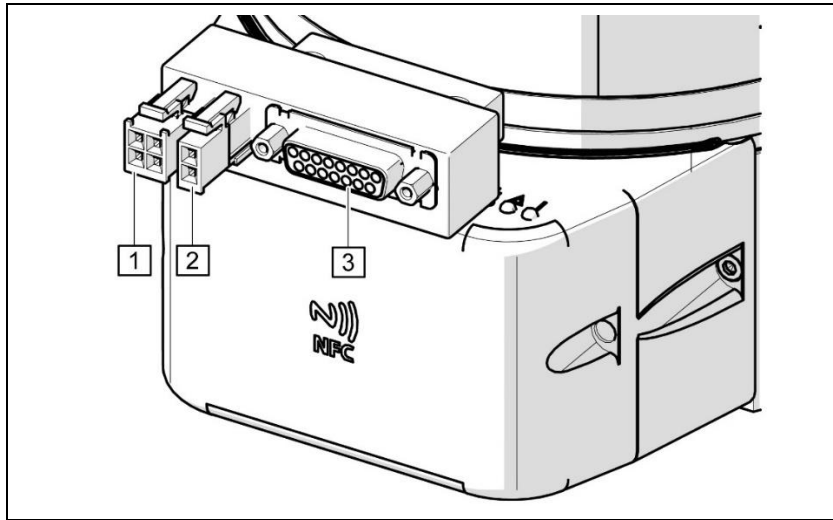
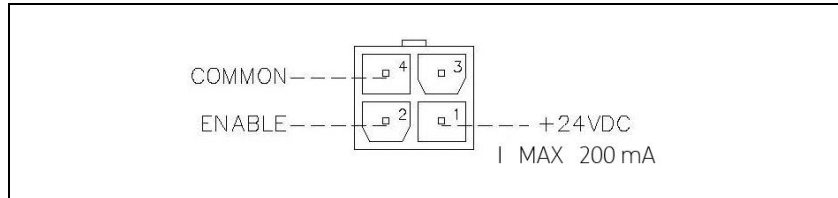

**Figure 45**

In the picture it is shown the adapter P/N X3514-68001 connected to the pump.

- 1 Vent valve connector.
- 2 Cooling fan connector.
- 3 Connector DB15 for power supply and serial communication and remote inputs and outputs control.

## 1 - Vent



**Figure 46** P3-Vent

This is a dedicated 24 Vdc connector to control the optional vent valve.

## 2 - External Fan

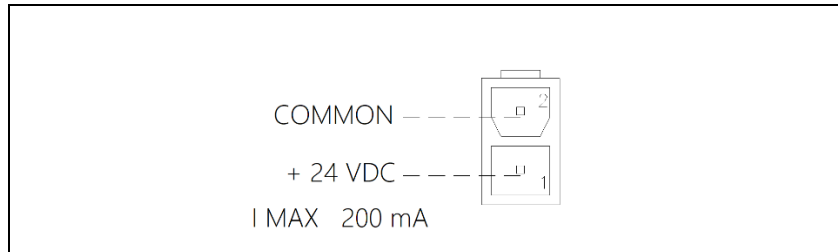

**Figure 47** External fan

This is a dedicated 24 Vdc connector to supply the optional external fan.

## 3 - IN/OUT and Power Supply

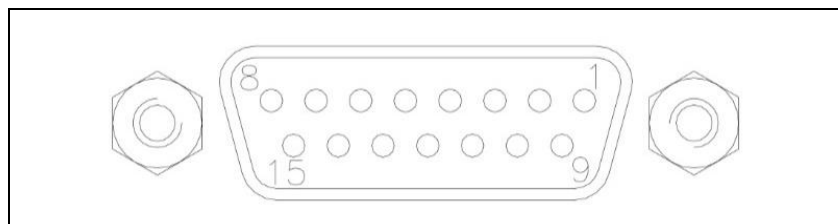

**Figure 48** IN/OUT and Power Supply

This connector carries all the input and output signals to remote control the TwisTorr 305-IC.

It is a 15-pins D type connector; the available signals are detailed in the table, the following paragraphs describe the signal characteristics and use.

**Tab. 2** Signal characteristics and use

PIN N.	SIGNAL NAME	DESCRIPTION	ELECTRIC RATING	NOTE
1	+24VDC IN	Supply Voltage Input	Nominal voltage: +24 VDC; Min voltage: +22.8 VDC; Max voltage: +25.2 VDC; Max absorption 7.5 A	
2	SOFT START	Digital Input (DI) Soft Start	Logic Input High Level: Nominal Value: +24 VDC Input range: +13 VDC to +33 VDC Logic Input Low Level: Nominal Value: 0 VDC Logic Input Low Level, Nominal Value: 0 VDC; Input range: -33 VDC to +7 VDC, Max current: ±5mA	Refer to Fig. 52
3	START/STOP	Digital Input (DI1) Start/Stop		
4	RFU	Digital Input (DI2), reserved for future use		
5	INTERLOCK	Digital Input (DI), Interlock		
6	LOW SPEED/ SPEED SETTING	Digital Input (DI); Speed Setting		
7	+24VDC OUTPUT (V+)	Supply Voltage Output for digital input	Nominal voltage: +24 VDC Max current: 30 mA	
8	NORMAL/ SETPOINT	Digital Output (DO1), Normal/Setpoint	Logic Output active voltage, Nominal value: +24 VDC; Max current: 50 mA	Refer to Fig. 53
9	FAULT	Digital Output (DO2), Fault		
10	EXTERNAL FAN	Digital Output for Accessory (A1), External Fan		
11	VENT VALVE	Digital Output for Accessory (B1), Vent Valve		
12	ANALOG OUTPUT	Programmable Analog Output (A01); Default setting: Rotational Speed	Analog Output 0-10 VDC; Max current: 1 mA	

**For RS232 communication:**

13	TX	RS232 COM PORT	Standard RS232, 8 bit no parity bit, n.1 start bit, n.1..2 stop bit
14	RX	RS232 COM PORT	

**For RS485 communication:**

13	TX	RS485 COM PORT	Standard RS485, 8 bit no parity bit, n.1 start bit, n.1..2 stop bit
14	RX	RS485 COM PORT	
15	GND	Supply Voltage Input	

**Note:** All potentials refer to pin 15 (GND).

# Signal Description

**Start/Stop:** input signal to start or stop the pump. With the supplied cover connector the START/STOP (+) signal is connected to the +24 Vdc pin and the START/STOP (-) signal to the GROUND pin: in this condition the pump automatically starts as soon as the controller recognises the input supply ("Plug & Pump").

**Interlock:** input signal to control the pump rotation. With the supplied cover connector the interlock (+) signal is connected to the +24 Vdc pin and the interlock (-) signal to the GROUND pin.

**Soft start:** this input is used to provide a "soft start" to the pump; in this condition the ramp-up time could be up to 45 min.

**Speed setting:** PWM input signal to set the pump speed. The PWM signal characteristics must be the following:

- frequency: 100 Hz +/-20%
- amplitude: +24VDC  $\pm$  10%
- duty cycle range: from 25% to 75% ( $t_{off}/T$ ) corresponding to a rotational frequency varying linearly from 700 Hz to the target frequency value set via serial command (default factory setting 1010 Hz). With duty cycle <25% rotational frequency = 700 Hz, duty cycle >75% rotational frequency = target frequency value (deviation value <0.25%).

#### NOTE

- (1) The Speed Setting input is able to work also with a PWM signal having an amplitude equal to 13VDC or to 33VDC. In these conditions, the accuracy of the speed setting is affected by a deviation value <1%.
- (2) Due to the fact that the rotational target frequency value is adjustable via serial command (refer to the "Windows meanings"), the input condition in which the PWM duty cycle >75% will ensure a rotational frequency equal to the one that has been set via the serial command; the default factory setting for the rotational target frequency is 1010Hz.

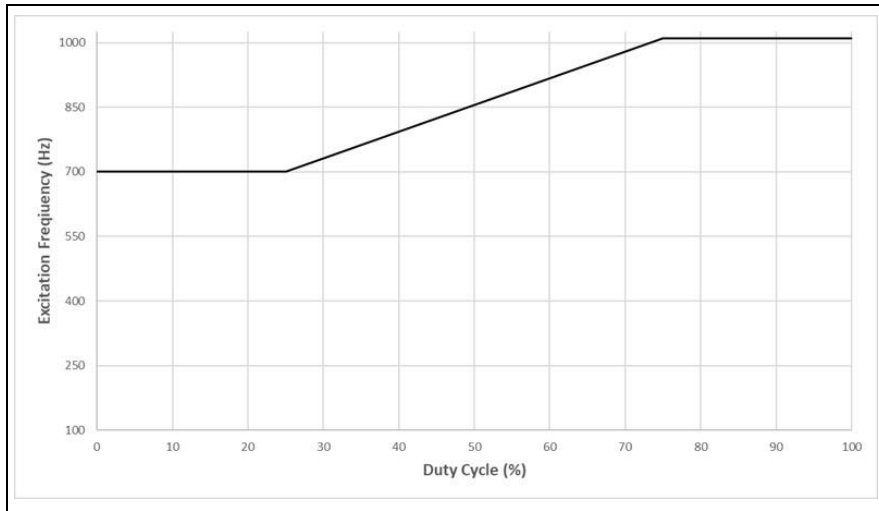

**Figure 49** Speed setting via PWM signal

**Programmable analog signal:** this output signal is a voltage (from 0 to 10 Vdc) proportional to a reference size (Frequency or Power or Temperature) set by the user. The default factory setting is the rotational frequency (see the following example diagram). The user can set the reference size by acting via serial command.

When the reference size is Power, the relation is:

ANALOG OUTPUT  $V_{out} = 10V$  --> Output power = 200W

When the reference size is Temperature, the relation is ANALOG OUTPUT

$V_{out} = 10V$  --> Pump Body Temperature = 125°C

## 8 Technical Information

### Signal Description

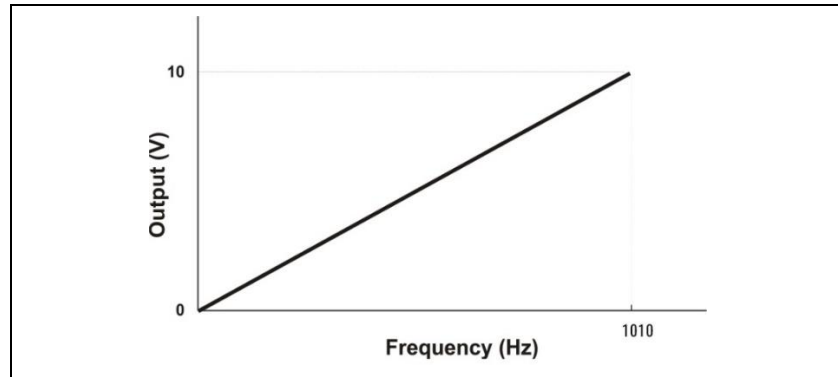

**Figure 50** Programmable analog output signal

**Fault:** this open collector output signal is ON when a system fault condition is detected.

**Programmable set point:** this open collector output signal is enabled when the reference quantity chosen (frequency, current or time) is higher than the set threshold. The signal can be "high level active" (that is the output is normally at 0 Vdc and becomes 24 Vdc when activated), or "low level active" (that is the output is normally at 24 Vdc and becomes 0 Vdc when activated). Moreover, if the reference quantity is the frequency or the current drawn, it is possible to set the hysteresis (in % of the threshold value) to avoid bouncing.

For example:

- reference quantity: frequency
- threshold: 500 Hz
- hysteresis: 1%
- activation type: "high level"

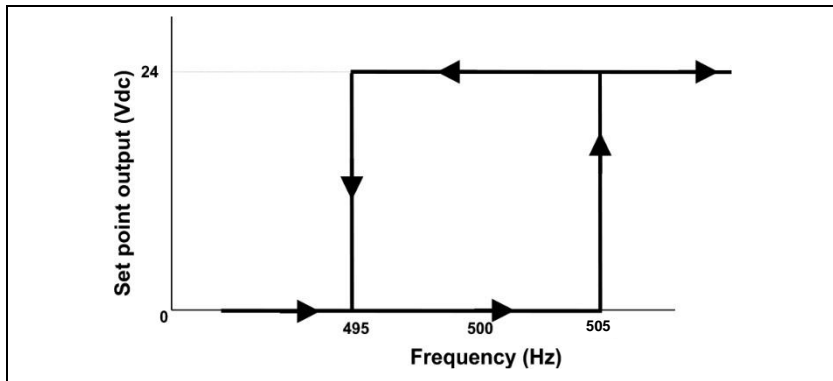

**Figure 51** Programmable setpoint

The set point output stays at 0 Vdc until the frequency becomes higher than 505 Hz (that is 500 Hz + 1% of 500 Hz), then the output goes at 24 Vdc and stays at 24 Vdc until the frequency becomes lower than 495 Hz (that is 500 Hz – 1% of 500 Hz).

It is possible to delay the set point checking for a programmable delay time. The PROGRAMMABLE SET POINT signal has the following default settings:

- reference quantity: frequency
- threshold: 909 Hz
- hysteresis: 2 %
- activation type: high level
- delay time: 0 second

**NOTE**

The TwisTorr 305-IC Software (optional) allows the operator to set all the programmable feature.

## 8 Technical Information

### How to Connect the Open Collector Inputs of the Controller

# How to Connect the Open Collector Inputs of the Controller

Here below there are the typical connections of the open collector input of the integrated controller to an external system.

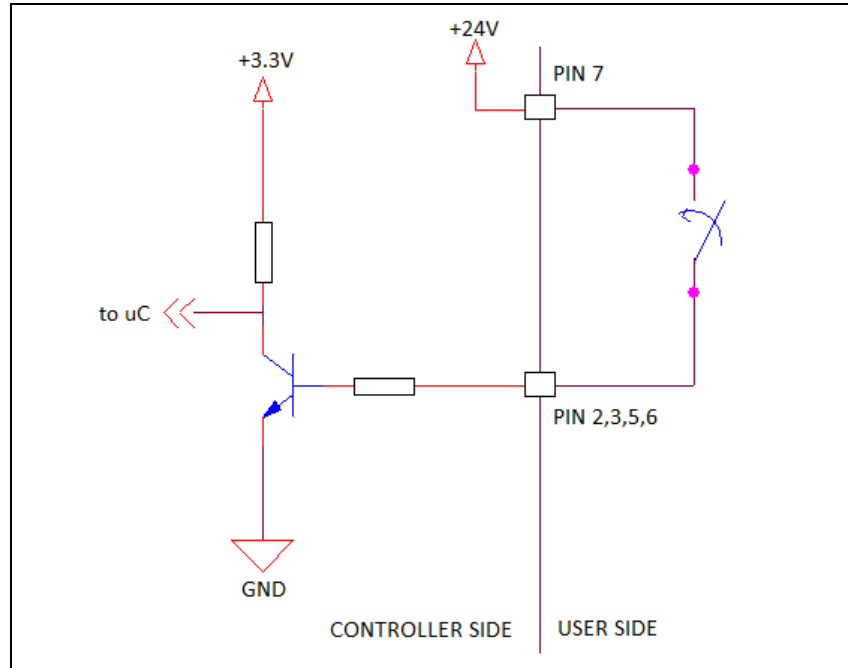

Figure 52 Reference connection circuit for digital input

### WARNING!



If the power supply for the digital input is supplied by an external power supply then pin 15 on the controller should be connected to ground.

## How to Connect the Controller Outputs

The following figure shows a typical logic output connection for pin 8, 9, 10 or 11.

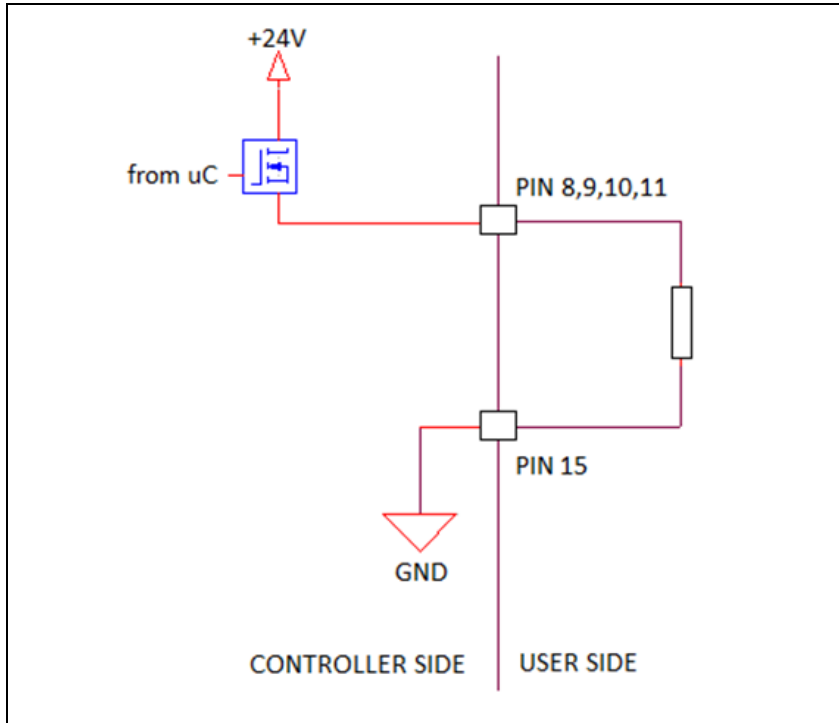

**Figure 53** Reference connection circuit for digital output circuit

## RS485/RS232 communication description

Depending on the model of the pump, either the RS485 or the RS232 interface is available. The list of part numbers with RS485 is the following:

X3513-64000	TWISTORR 305-IC ISO100K 485AGI AIR COOLING
X3513-64001	TWISTORR 305-IC CFF6 485AGI AIR COOLING
X3513-64002	TWISTORR 305-IC ISO160K 485AGI AIR COOLING
X3513-64003	TWISTORR 305-IC CFF8 485AGI AIR COOLING
X3513-64004	TWISTORR 305-IC ISO100K 485AGI WATER COOLING
X3513-64005	TWISTORR 305-IC CFF6 485AGI WATER COOLING
X3513-64006	TWISTORR 305-IC ISO160K 485AGI WATER COOLING
X3513-64007	TWISTORR 305-IC CFF8 485AGI WATER COOLING
X3513-64016	TWISTORR 305-IC ISO100K 485P AIR COOLING
X3513-64017	TWISTORR 305-IC CFF6 485P AIR COOLING
X3513-64018	TWISTORR 305-IC ISO160K 485P AIR COOLING
X3513-64019	TWISTORR 305-IC CFF8 485P AIR COOLING
X3513-64020	TWISTORR 305-IC ISO100K 485P WATER COOLING
X3513-64021	TWISTORR 305-IC CFF6 485P WATER COOLING
X3513-64022	TWISTORR 305-IC ISO160K 485P WATER COOLING
X3513-64023	TWISTORR 305-IC CFF8 485P WATER COOLING

The list of part numbers with RS232 is the following:

X3513-64024	TWISTORR 305-IC ISO100K 232AGI AIR COOLING
X3513-64025	TWISTORR 305-IC CFF6 232AGI AIR COOLING
X3513-64026	TWISTORR 305-IC ISO160K 232AGI AIR COOLING
X3513-64027	TWISTORR 305-IC CFF8 232AGI AIR COOLING
X3513-64028	TWISTORR 305-IC ISO100K 232AGI WATER COOLING
X3513-64029	TWISTORR 305-IC CFF6 232AGI WATER COOLING
X3513-64030	TWISTORR 305-IC ISO160K 232AGI WATER COOLING
X3513-64031	TWISTORR 305-IC CFF8 232AGI WATER COOLING

The communication protocol is the same (see the structure below), but only the RS 485 manages the address field.

**Communication Format**

- 8 data bit
- no parity
- 1 stop bit
- baud rate: 600/1200/2400/4800/9600 programmable

For the following P/Ns

- X3513-64016 TWISTORR 305-IC ISO100K 485P AIR COOLING
- X3513-64017 TWISTORR 305-IC CFF6 485P AIR COOLING
- X3513-64018 TWISTORR 305-IC ISO160K 485P AIR COOLING
- X3513-64019 TWISTORR 305-IC CFF8 485P AIR COOLING
- X3513-64020 TWISTORR 305-IC ISO100K 485P WATER COOLING
- X3513-64021 TWISTORR 305-IC CFF6 485P WATER COOLING
- X3513-64022 TWISTORR 305-IC ISO160K 485P WATER COOLING
- X3513-64023 TWISTORR 305-IC CFF8 485P WATER COOLING

Please contact Agilent Technical Support for details on the type of communication protocol to be used on the serial interface and relative command format.

## Windows Protocol

The Windows Protocol is a MASTER/SLAVE type where:

- Host = MASTER
- Controller = SLAVE

The communication is performed in the following way:

1. the host (MASTER) send a MESSAGE + CRC to the controller (SLAVE);
2. the controller answer with an ANSWER + CRC to the host.

The MESSAGE is a string with the following format:

<STX>+<ADDR>+<WIN>+<COM>+<DATA>+<ETX>+<CRC>

where:

### NOTE

When a data is indicated between two quotes ('...') it means that the indicated data is the corresponding ASCII character.

- 
- <STX> (Start of transmission) = 0x02
  - <ADDR> (Unit address) = 0x80 (for RS 232)  
<ADDR> (Unit address) = 0x80 + device number (0 to 31)  
(for RS 485)
  - <WIN> (Window) = a string of 3 numeric character indicating the window number (from '000' to '999'); for the meaning of each window see the relevant paragraph.
  - <COM> (Command) = 0x30 to read the window, 0x31 to write into the window
  - <DATA> = an alphanumeric ASCII string with the data to be written into the window. In case of a reading command this field is not present. The field length varies according to the data type as shown in the following table:

**Tab. 3**

DATA TYPE	FIELD LENGTH	VALID CHARACTERS
Logic (L)	1	'0' = off '1' = on
Numeric (N)	6	'-', '.', '0' ... '9' right justified with '0'
Alphanumeric (A)	10	from blank to ' _ ' (ASCII)

- <ETX> (End of transmission) = 0x03
- <CRC> = XOR of all characters subsequent to <STX> and including the <ETX> terminator. The value is hexadecimal coded and indicated by two ASCII character.

The addressed SLAVE will respond with an ANSWER whose structure depends from the MESSAGE type.

When the MESSAGE is a reading command, the SLAVE will respond transmitting a string with the same structure of the MESSAGE.

**NOTE**

Using the RS 485 interface, the message structure remains identical to the one used for the RS 232 interface, the only difference is the value assigned to the ADDRESS <ADDR>.

## 8 Technical Information

### Windows Protocol

The controller can answer with the following response types:

**Tab. 4**

<b>TYPE</b>	<b>LENGTH</b>	<b>VALUE</b>	<b>DESCRIPTION</b>
Logic	1 byte	-	After a read instruction of a logic window
Numeric	6 byte	-	After a read instruction of a numeric window
Alphanumeric	10 byte	-	After a read instruction of an alphanumeric window
ACK	1 byte	(0x6)	The command execution has been successfully completed
NACK	1 byte	(0x15)	The command execution has been failed
Unknown Window	1 byte	(0x32)	The specified window in the command is not a valid window
Data Type Error	1 byte	(0x33)	The data type specified in the command (Logic, Numeric or Alphanumeric) is not accorded with the specified Window
Out of Range	1 byte	(0x34)	The value expressed during a write command is out of the range value of the specified Window
Win Disabled	1 byte	(0x35)	The specified window is Read Only or temporarily disabled (for example you can't write the Soft Start when the Pump is running)

Examples:

**Command: START**

Source: PC

Destination: Controller

02	80	30	30	30	31	31	03	42	33
STX	ADDR	WINDOW			WR	ON	ETX	CRC	

Source: Controller

Destination: PC

02	80	06	03	38	35
STX	ADDR	ACK	ETX	CRC	

**Command: STOP**

Source: PC

Destination: Controller

02	80	30	30	30	31	30	03	42	33
STX	ADDR	WINDOW			WR	OFF	ETX	CRC	

Source: Controller

Destination: PC

02	80	06	03	38	35
STX	ADDR	ACK	ETX	CRC	

## 8 Technical Information

### Windows Protocol

#### Command: SOFT-START (ON)

Source: PC

Destination: Controller

02	80	31	30	30	31	31	03	42	33
STX	ADDR	WINDOW			WR	ON	ETX	CRC	

Source: Controller

Destination: PC

02	80	06	03	38	35
STX	ADDR	ACK	ETX	CRC	

#### Command: SOFT-START (OFF)

Source: PC

Destination: Controller

02	80	31	30	30	31	30	03	42	33
STX	ADDR	WINDOW			WR	OFF	ETX	CRC	

Source: Controller

Destination: PC

02	80	06	03	38	35
STX	ADDR	ACK	ETX	CRC	

## Window Description

WIN #	READ	WRITE	TYPE	NAME	MEANING
0	Always	Serial	L	Start/Stop	Start/Stop command
1	Always	Serial	L	Low Speed	Low Speed command
8	Always	Always	A	Serial/Remote	Configures controller
100	Always	Stop & Serial	L	Soft Start	Enable/Disable Soft Start option
101	Always	Always	N	Setpoint Type	It defines set point type: 0 = Frequency 1 = Power 2 = Time 3 = Normal
102	Always	Always	N	Setpoint Value	It defines the threshold value for Set Point
103	Always	Always	N	Setpoint Delay	It defines the setpoint mask time from start
104	Always	Always	L	Setpoint Logic	It defines the functionally logic. "High level active" indicates an output ON when the signal is above the threshold and "Low level active" is the opposite.
105	Always	Always	N	Setpoint hysteresis	It defines the percentage value of Set Point Hysteresis
108	Always	Always	N	Baud Rate	It defines the serial communication baud rate: 0 = 600 bit/s 1 = 1200 bit/s 2 = 2400 bit/s 3 = 4800 bit/s 4 = 9600 bit/s 5 = 19200 bit/s 6 = 38400 bit/s
109	Always	Always	L	Pump Life Reset	Pump Life Reset
110	Always	Always	L	Interlock Type	It defines the interlock type. The interlock can be checked at start or continuously
111	Always	Always	N	Analog Output Type	It defines the analog output type: 0 = Frequency (10V = OMEGA_MAX_ABS) 1 = Power (10V = P_RANGE) 2 = Body Temperature (10V = 125°C)
117	Always	Always	N	Low Speed Adjust Frequency	It defines the Low Speed frequency value
120	Always	Always	N	Target Frequency	It defines the target excitation frequency
121	Always	Always	N	Maximum frequency	It defines the maximum frequency settable by WIN120
122	Always	Always	L	Set vent valve	Set vent valve
125	Always	Always	A	Set the vent valve operation	Set the vent valve operation 0 = Automatic 1 = On command
126	Always	Always	N	Vent valve opening delay	Vent valve opening delay (expressed in 0.2sec)

## 8 Technical Information

### Window Description

WIN #	READ	WRITE	TYPE	NAME	MEANING
143	Always	Always	N	External Fan Config	external fan configuration: 0 = Always On 1 = Serial (generic output serially controlled)
144	Always	Always	L	External Fan Setting	External fan setting
147	Always	Always	N	Vent valve opening time	Vent valve opening time (expressed in 0.2sec; 0=infinite)
157	Always	Always	N	Gas Load Type	0 = molar mass $\geq 30$ g/mol (e.g., Ar) 1 = 4 g/mol < molar mass < 30 g/mol (e.g., N <sub>2</sub> ) 2 = molar mass $\leq 4$ g/mol (e.g., H <sub>2</sub> , He)
167	Always	Stop	L	Stop speed reading	It reads the pump speed while in stop mode
200	Always	-	N	Bus current	It reads the actual value of the bus current supplied by controller to electric motor
201	Always	-	N	3phase voltage	It reads the actual value of the pk 3phase voltage supplied by controller to electric motor
202	Always	-	N	Output power	It reads the actual value of power supplied by controller to electric motor
203	Always	-	N	Driving frequency	This is the actual exciting frequency
204	Always	-	N	Body temperature	It reads the Body temperature
205	Always	-	N	Pump status	Real time pump status: 0 = Stop 1 = Interlock 2 = Ramp 3 = Autotuning 4 = Braking 5 = Normal 6 = Fail
206	Always	-	N	Error code	This location has a bit significant: 11 = Run Up Time 10 = Body HW Over Temp 9 = RFU/Not used 8 = Rotor Locked 7 = Too High Load 6 = Fault DRV8305 5 = Vdc (supply) Over Voltage 4 = Thermalpad Overtemp 3 = Vdc (supply) Under Voltage 2 = Controller Over Temp 1 = Pump Over Temp 0 = No connection to pump
211	Always	-	N	controller temperature	It reads the MOSFET bridge temperature
216	Always	-	N	controller temperature	It reads the controller PCB temperature
221	Always	-	L	Actual Setpoint Status	Reports the actual state of setpoint output

WIN #	READ	WRITE	TYPE	NAME	MEANING
228	Always	-	N	Warning code	This location has a bit 283 significant: 13 = A1 THERMALFAIL 12 = A2 THERMALFAIL 11 = D01 THERMALFAIL 10 = D02 THERMALFAIL 9 = V24VDC WARNING UNDERVOLTAGE 8 = ANALOGOUT OUT TOLL 7 = A1 UNDERLOAD 6 = A2 UNDERLOAD 5 = D01 UNDERLOAD 4 = D02 UNDERLOAD 3 = A1 OVERLOAD 2 = A2 OVERLOAD 1 = D01 OVERLOAD 0 = D02 OVERLOAD
231	Always	-	A	Standard Information Pump	Merging of standard information: 1° char = Status Pump (ref.Win 205) 2°,3°,4° char = Output power (ref.Win 202) 5°,6°,7°, 8° char = Driving Frequency (ref.Win 203) 9°,10°,11° char = Body temperature (ref.Win 204)
234	Always	-	N	Bus Voltage	It reads the Bus Voltage
300	Always	-	N	Cycle time	It indicates the time of the last cycle (from the last start to now if the pump is running)
301	Always	-	N	Cycle number	It indicates the number of cycles start/stop during all the pump life.
302	Always	-	N	Pump life	It indicates the total hours of pump life.
307	Always	-	N	Controller life	It indicates the total hours of controller in stand by
319	Always	-	A	Controller P/N	It is the Part Number of Controller
320	Always	-	A	Pump P/N	It is the Part Number of Pump
321	Always	-	A	Pump Special Model	It is a four chars code to identify the Part Number of special Pumps
322	Always	-	A	Pump S/N	It is the Serial Number of Pump
323	Always	-	A	Controller S/N	It is the Serial Number of Controller
324	Always	-	A	Pump Modification Level	It is the upgrading level of the pump
325	Always	-	A	Controller Modific. Level	It is the upgrading level of the controller
362	Always	-	N	Average Pump Temperature	It indicates the pump temperature filter value with T=1hour
363	Always	-	N	Average Current	It indicates the bus current filter value with T=1hour
364	Always	-	N	Average Power	It indicates the power supplied filter value with T=1hour
365	Always	-	N	Average Frequency	It indicates the driving frequency filter value with T=1hour
366	Always	-	N		Worst temp cycle number
367	Always	-	N		Worst temp cycle time
368	Always	-	N		Worst temp cycle temperature
369	Always	-	N		Worst temp cycle current

## 8 Technical Information

### Window Description

WIN #	READ	WRITE	TYPE	NAME	MEANING
370	Always	-	N		Worst temp cycle power
371	Always	-	N		Worst temp cycle frequency
372	Always	-	N		Worst power cycle number
373	Always	-	N		Worst power cycle time
374	Always	-	N		Worst power cycle temperature
375	Always	-	N		Worst power cycle current
376	Always	-	N		Worst power cycle power
377	Always	-	N		Worst power cycle frequency
382	Always	-	N	Average Pump Temperature	It indicates the average pump temperature
384	Always	-	N	Average Pump Power	It indicates the average supply power
399	Always	-	N	Controller life	It indicates the total hours of controller life
400	Always	-	A	Program Listing CRC	It is the CRC of the actual embedded program listing
401	Always	-	A	Bootloader CRC	It is the CRC of the embedded bootloader program
402	Always	-	A	Parameter Listing CRC	It is the CRC of the actual embedded parameter listing
404	Always	-	A	Parameter Listing Struct.CRC	It defines the structure of Parameter Listing accepted by embedded Program Listing
406	Always	-	A	Program Listing code and revision	It defines the structure of Program Listing accepted by embedded Program Listing
407	Always	-	A	Parameter Listing code and revision	It indicates code and release of embedded Parameter Listing
503	Always	Always	N	RS485 Address	It defines the serial address in RS485 communication (accessible with every serial address)
724	Always	Always	N	Run Up time	Run Up time
725	Always	Always	L	RUTimeCtrl	Run Up time control

Below is the table with the Admitted Values:

WIN #	MIN	MAX	0 VALUE	1 VALUE	UNIT
0			Stop	Start	-
1			Off	On	-
8			Serial	Remote	-
100			Disable	Enable	-
101	0	3			-
102	0	99999			Hz/W/s
103	0	999999			s
104			High Level	Low Level	-
105	0	100			%
108	0	6			-

WIN #	MIN	MAX	0 VALUE	1 VALUE	UNIT
109			-	Reset	-
110			Impulse	Continuous	-
111	0	2			-
117					Hz
120					Hz
121					Hz
122			Off	On	-
125	0	2			-
126	0	65535			0,2s
143	0	1			-

WIN #	MIN	MAX	0 VALUE	1 VALUE	UNIT
144			Off	On	-
147	0	65535			0,2s
157	0	2			
167			Off	On	-
200					mA
201					1/10V
202					W
203					Hz
204					°C
205					-
206					-
211					°C
216					°C
221			Off	On	-
228					-
231					
234					1/100V
300					min
301					-
302					hours
307					hours
319		11 chars			-
320		11 chars			-
321		4 chars			-
322		10 chars			-
323		10 chars			-
324		10 chars			-
325		10 chars			-

WIN #	MIN	MAX	0 VALUE	1 VALUE	UNIT
362					°C
363					mA
364					W
365					Hz
366					-
367					min
368					°C
369					mA
370					W
371					Hz
372					-
373					min
374					°C
375					mA
376					W
377					Hz
382					°C
384					W
399					hours
400					-
401					-
402					-
404					-
406					-
407					-
503	0	31			-
724	0	30			min
725			Off	On	-

## 8 Technical Information

### Window Description

#### NOTE

1. Automatic means that when the controller stops, the vent valve is opened with a delay defined by window n. 126; when the controller starts, the vent valve is immediately closed.
2. On command means that the vent valve is opened or closed by means of window n. 122.
3. These commands remove the pump motor supply for a short time. If they are used continuously, they can cause the pump stopping.

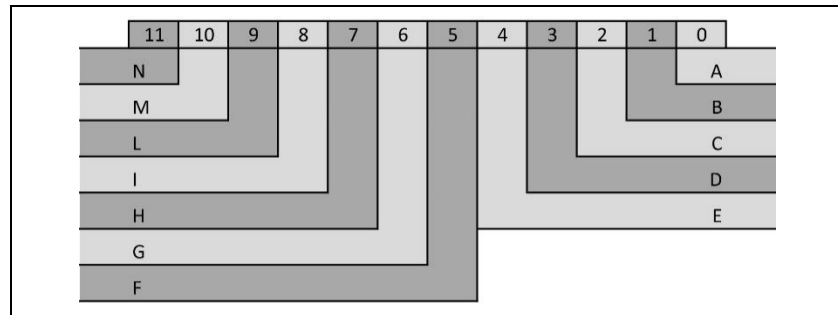
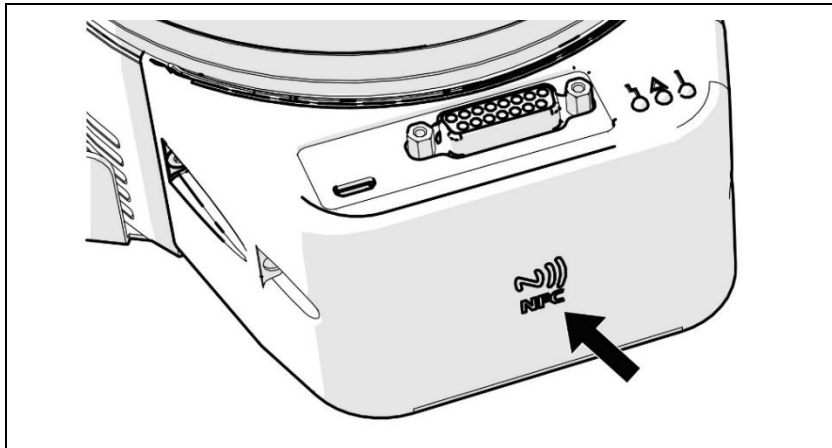

**Figure 54** Window N. 206 Bit Description

- A:** No connection to pump
- B:** Pump over temperature
- C:** Controller over temperature
- D:** Vdc under voltage
- E:** Thermal pad over temperature
- F:** Vdc over voltage
- G:** Fault DRV8305
- H:** Too high load
- I:** Rotor locked
- L:** RFU/Not used (RFU=Reserved for Future Use)
- M:** Body HW over temperature
- N:** Run Up Time

## NFC Function

“Near Field Communication” (NFC), is a technology that provides short-range connectivity.



**Figure 55** NFC Antenna

In order to establish communication between the controller and external device (smartphone or tablet) the VacuumLink app must be installed first from Google Play or Apple Store. The app is available for both Android and iOS. Once installed, you can establish a connection by holding the smart device up to the NFC icon on the controller.

---

**WARNING!**



Before downloading the dedicated App, check the compatibility with the operating system of the device used.

---

## 8 Technical Information

### NFC Function

To use this function, after opening the VacuumLink App, make sure to align the NFC antenna of the smartphone with the NFC icon on the controller and take the smartphone at a distance less than 2 cm (1 in).

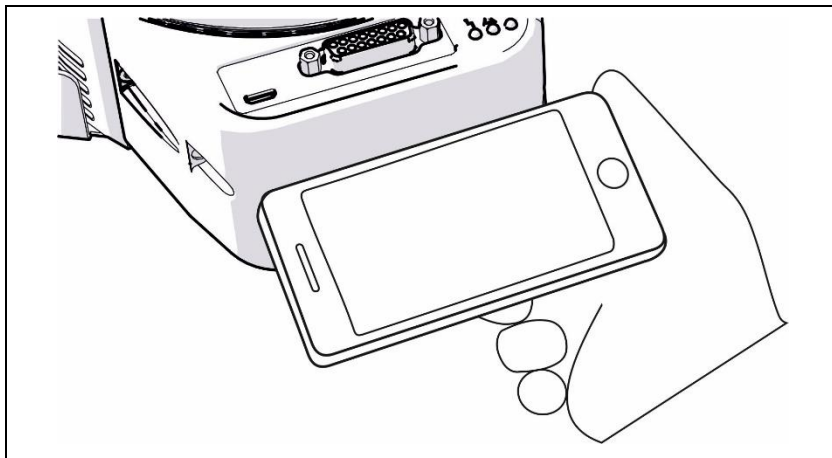
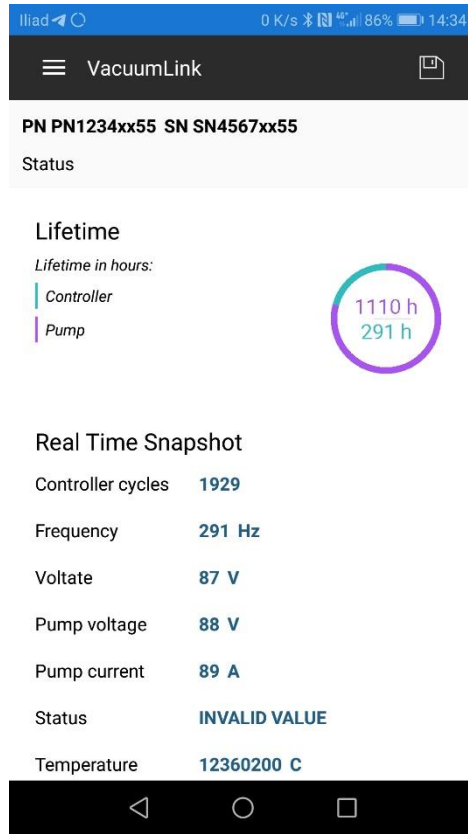
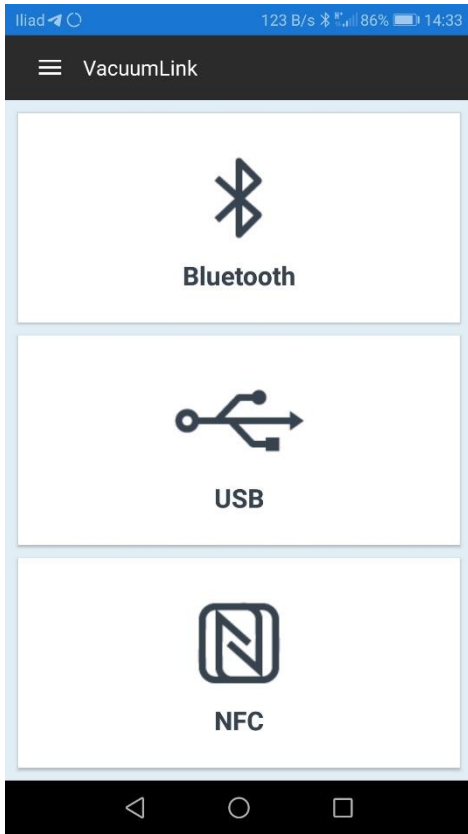

**Figure 56** NFC connection with 305-IC and mobile devices

#### NOTE

This function can also be used when the pump is off.

# Screenshot APP



## Connection through USB plug

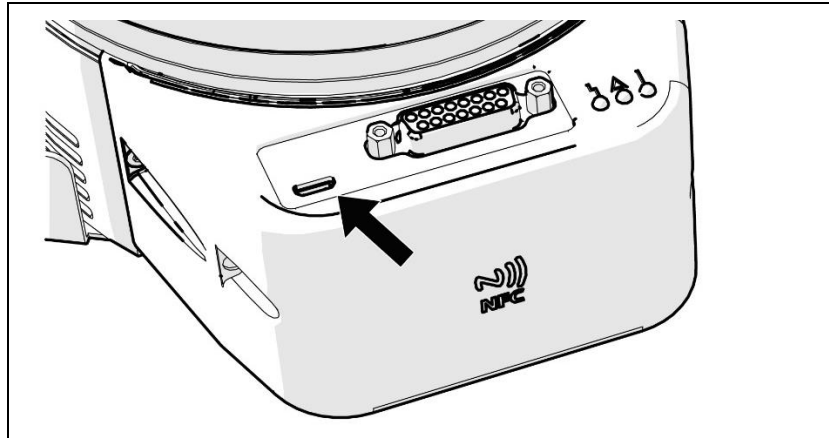

**Figure 57** USB Port

- 1) Connect the Micro USB "B" cable to the 305-IC.
- 2) The USB port is recognized by PC as "Virtual COM".
- 3) All windows and related features of the Windows protocol are available on the "Virtual COM" port.

---

**WARNING!**



Do not use the USB port for writing simultaneously with the main serial (DB15).

---

## Error messages

In case a failure occurs, the controller will generate an error message.  
Please see the list below for guidance.

MESSAGE	DESCRIPTION	ACTION	LED STATUS (for ref)		
			Red	Yellow	Green
Run Up Time	The pump has not been able to reach a speed value >700 Hz, within the expected value (Run Up Time, which is configurable). The Run Up Time value can be set acting on the serial Win#724.	Check for the Run UP Time set-up: it should be set accordingly to the customer process. Check for the gas load flowing inside the pump and adjust it accordingly. Check that the pump rotor can rotate freely. Restart the pump	ON, Solid	OFF	ON, Inv Flash
Body HW Over Temp	The temperature of the pump has exceeded the maximum allowed value. This overtemperature condition is detected by a hardware circuitry. This overtemperature condition is detected by a hardware circuitry, which is independent from the microprocessor. The maximum allowed value is 62°C	Check for the pump cooling system functionality (forced air or liquid). Check for the Gas Load Selection setting; it has to be in compliance with the gas type used by the application. Wait for the pump temperature to return below the related threshold. Restart the pump.	ON, Solid	OFF	ON, Inv Flash
Rotor Locked	The pump rotor is not able to spin	Check that the pump rotor can rotate freely. If not, contact Agilent to get appropriate directions	ON, Solid	OFF	ON, Inv Flash
Too High Load	The supply current flowing into by the pump is higher than the expected value	Verify the inlet and foreline pressure are within specified limits. Check for the pump rotor can spin freely. Restart the pump	ON, Solid	OFF	ON, Inv Flash
Fault DRV8305	Mosfet bridge driver failure	Contact Agilent to get appropriate directions	ON, Solid	OFF	ON, Inv Flash

## 8 Technical Information

### Error messages

MESSAGE	DESCRIPTION	ACTION	LED STATUS (for ref)		
			Red	Yellow	Green
VDC Over Voltage	The supply input voltage value is too high (>26.4V).	Check for the supply voltage value, it has to comply with the specified range Check for the electrical connection between the power supply and the electronic controller Restart the pump	ON, Solid	OFF	ON, Inv Flash
Thermalpad Overtemp	Thermal connection between control unit and heatsink has failed	Contact Agilent to get appropriate directions	ON, Solid	OFF	ON, Inv Flash
VDC Under Voltage	The supply input voltage value is too low (<21.6V).	Check for the supply voltage value, it has to comply with the specified range Check for the electrical connection between the power supply and the electronic controller Restart the pump	ON, Solid	OFF	ON, Inv Flash
Controller Over Temp	The temperature of the electronic control unit has exceeded the maximum allowed value (68°C) This overtemperature condition is detected by the control unit microprocessor	Check for the pump cooling system functionality (forced air or liquid) Wait for the controller temperature to return below the related threshold. Restart the pump.	ON, Solid	OFF	ON, Inv Flash
Pump Over Temp	The temperature of the pump has exceeded the maximum allowed value. This overtemperature condition is detected by the control unit microprocessor The value depends on the Gas Load selection, as shown below: (Ar) --> 50°C (N <sub>2</sub> ) --> 55°C (He) --> 60°C	Check for the pump cooling system functionality (forced air or liquid) Check for the Gas Load settings; it has to be in compliance with the gas type used by the application Wait for the pump temperature to return below the related threshold. Restart the pump.	ON, Solid	OFF	ON, Inv Flash

## Warning messages

MESSAGE	DESCRIPTION	ACTION	LED STATUS (for ref)		
			Red	Yellow	Green
CK_RTC_RESET	Real Time Clock malfunction	Contact Agilent to get the appropriate directions	OFF/ON Solid	ON, Solid	Blinking/Flashing/ Inv.Flashing/Solid
A1 THERMALFAIL	A1 Accessory Output shut down due to its overtemperature protection intervention	Power off the unit in order to allow it to cool down quickly. Remove all the loads which are applied to the output; check the loads electrical ratings (they have match with the output specifications); check the loads for short circuits absence/lack of insulation Power on the unit, without any load, the yellow led light must be turned off if YES, reconnect the load If NO, contact Agilent to get the appropriate directions	OFF/ON Solid	ON, Solid	Blinking/Flashing/ Inv.Flashing/Solid
B1 THERMALFAIL	B1 Accessory Output shut down due to its overtemperature protection intervention		OFF/ON Solid	ON, Solid	Blinking/Flashing/ Inv.Flashing/Solid
D01 THERMALFAIL	D01 Digital Output shut down due to its overtemperature protection intervention		OFF/ON Solid	ON, Solid	Blinking/Flashing/ Inv.Flashing/Solid
D02 THERMALFAIL	D02 Digital Output shut down due to its overtemperature protection intervention		OFF/ON Solid	ON, Solid	Blinking/Flashing/ Inv.Flashing/Solid
V24VDC WARNING UNDERVOLTAGE	+24VDC OUTPUT (V+), too high load condition applied to the output	Power off the unit. Remove all the loads which are applied to the output; check for the loads electrical ratings (they have to match with the output specifications); check for the loads absnce of short circuits/lack of insulation Power on the unit, without any load connected to the output; the yellow led light must be turned off immediately if YES, reconnect the load If NO, contact Agilent to get the appropriate directions	OFF/ON Solid	ON, Solid	Blinking/Flashing/ Inv.Flashing/Solid
ANALOGOUT OUT TOLL	A01 Analog Output, too high load condition applied to the output	Remove all the loads which are applied to the output; the yellow led light must be turned off immediately if YES, before reconnecting the load to the output, check it for its electrical ratings (they have to match with the output specifications) and check it for the absence of short circuits/lack of insulation If NO, contact Agilent to get the appropriate directions	OFF/ON Solid	ON, Solid	Blinking/Flashing/ Inv.Flashing/Solid

## 8 Technical Information

### Warning messages

MESSAGE	DESCRIPTION	ACTION	LED STATUS (for ref)		
			Red	Yellow	Green
A1 OVERLOAD	A1 Accessory Output is ACTIVE, too high load is connected to the output	Remove all the loads which are applied to the output; the yellow led light must be turned off immediately. If YES, before reconnecting the load to the output, check it for its electrical ratings (they have to match with the output specifications) and check it for the absence of short circuits/lack of insulation If NO, contact Agilent to get the appropriate directions	OFF/ON Solid	ON, Solid	Blinking/Flashing/ Inv.Flashing/Solid
B1 OVERLOAD	B1 Accessory Output is ACTIVE, too high load is connected to the output		OFF/ON Solid	ON, Solid	Blinking/Flashing/ Inv.Flashing/Solid
D01 OVERLOAD	D01 Digital Output is ACTIVE, too high load is connected to the output		OFF/ON Solid	ON, Solid	Blinking/Flashing/ Inv.Flashing/Solid
D02 OVERLOAD	D02 Digital Output is ACTIVE, too high load is connected to the output		OFF/ON Solid	ON, Solid	Blinking/Flashing/ Inv.Flashing/Solid
A1 UNDERLOAD	A1 Accessory Output is ACTIVE, but the no load is connected to the output	These warnings don't cause the yellow led light to be turned on. These warnings are meaningful only if loads are connected to the related outputs. If a LOAD is applied to the output, then these warning conditions highligh the fact that no current is flowing from the output to the load upon the active level condition of the output. In order to reset these warnings, check the loads for the absence of an open circuit condition (check also for the connection cables -load/unit-integrity). If NO LOAD is applied to the outputs, these warnings are meaningless, please disregard them.	OFF/ON Solid	OFF	Blinking/Flashing/ Inv.Flashing/Solid
B1 UNDERLOAD	B1 Accessory Output is ACTIVE, but the no load is connected to the output		OFF/ON Solid	OFF	Blinking/Flashing/ Inv.Flashing/Solid
D01 UNDERLOAD	D01 Digital Output is ACTIVE, but the no load is connected to the output		OFF/ON Solid	OFF	Blinking/Flashing/ Inv.Flashing/Solid
D02 UNDERLOAD	D02 Digital Output is ACTIVE, but the no load is connected to the output		OFF/ON Solid	OFF	Blinking/Flashing/ Inv.Flashing/Solid

## Accessories and Spare Parts

**Tab. 5** Accessories and spare parts

DESCRIPTION	PART NUMBER
Air cooling kit (Kit X3514-68001 is required)	X3500-68010
Water Cooling Kit for Turbopump	9699337
Plastic Water Cooling Kit	9699347
Vent Valve N.O. 1, 2 mm (Kit X3514-68001 is required)	9699834
Vent Valve N.O. 0,5 mm (Kit X3514-68001 is required)	9699834M006
DB15 Mating Connector not wired 7.5A	X3514-68000
TwisTorr 305-IC Fan/Vent Adapter kit	X3514-68001
Inlet screen ISO 100	X3500-68000
Inlet Screen CFF 6"	9699302
Inlet Screen ISO 160	X3500-68001
Inlet Screen CFF 8"	9699304
KF25 Foreline Flange Assy	X3513-68000
Vibration Isolator ISO 100	9699344
Vibration Isolator CFF 6"	9699334
Vibration Isolator ISO 160	9699345
Vibration Isolator CFF 8"	9699335
Purge valve 10 SCCM NW16KF - M12	9699239
Purge valve 10 SCCM ¼ Swagelock M12	9699240
Purge valve 20 SCCM NW16KF – M12	9699241
Purge valve 20 SCCM ¼ Swagelock - M12	9699242
Purge valve 10 SCCM ¼ Swagelock - ¼ Swagelock	9699232
Purge valve 20 SCCM ¼ Swagelock - ¼ Swagelock	9699236
Active Gauges	Ask Agilent for details

**NOTE**

The communication S/W between the controller and the pump (A-Plus) is available on the Agilent website:

<https://www.agilent.com/en/products/vacuum-technologies/vacuum-leak-detection-software/a-plus-software>

The connection is provided through USB (use a standard USB A male - USB B male).

**8 Technical Information**  
Accessories and Spare Parts

Page intentionally left blank



***Vacuum Products Division***

*Dear Customer,*

*Thank you for purchasing an Agilent vacuum product. At Agilent Vacuum Products Division we make every effort to ensure that you will be satisfied with the product and/or service you have purchased.*

*As part of our Continuous Improvement effort, we ask that you report to us any problem you may have had with the purchase or operation of our products. On the back side you find a Corrective Action request form that you may fill out in the first part and return to us.*

*This form is intended to supplement normal lines of communications and to resolve problems that existing systems are not addressing in an adequate or timely manner.*

*Upon receipt of your Corrective Action Request we will determine the Root Cause of the problem and take the necessary actions to eliminate it. You will be contacted by one of our employees who will review the problem with you and update you, with the second part of the same form, on our actions.*

*Your business is very important to us. Please, take the time and let us know how we can improve.*

*Sincerely,*

A handwritten signature in black ink, appearing to read "Giampaolo LEVI".

*Giampaolo LEVI*

*Vice President and General Manager  
Agilent Vacuum Products Division*

Note: Fax or mail the Customer Request for Action (see backside page) to Agilent Vacuum Products Division (Torino) – Quality Assurance or to your nearest Agilent representative for onward transmission to the same address.



## Vacuum Products Division Instructions for returning products

Dear Customer,

Please follow these instructions whenever one of our products needs to be returned.

Complete the attached **Request for Return form** and send it to Agilent Technologies (see below), taking particular care to include the completed **Health and Safety** declaration Section. No work can be started on your unit until we receive a completed copy of this form.

After evaluating the information, Agilent Technologies will provide you with a **Return Authorization (RA) number** via email or fax, as requested. Note: Depending on the type of return, a Purchase Order may be required at the time **the Request for Return is submitted**. We will quote any necessary services (evaluation, repair, special cleaning, eg).

### Product preparation

- Remove all accessories from the core product (e.g. inlet screens, vent valves).
- Prior to shipment and if applicable for your product, drain any oils or other liquids, purge or flush all gasses, and wipe off any excess residue.
- If ordering an Advance Exchange product, please use the packaging from the Advance Exchange to return the defective product.
- Seal the product in a plastic bag, and package product carefully to avoid damage in transit. You are responsible for loss or damage in transit.
- Include a copy of the Health and Safety Declaration in the shipping documentation on the outside of the shipping box of your returning product.
- Clearly label package with RA number. Using the shipping label provided will ensure the proper address and RA number are on the package. Packages shipped to Agilent without a RA clearly written on the outside cannot be accepted and will be returned.
- Return only products for which the RA was issued.

### Shipping

- Ship to the location specified on the printable label, which will be sent, along with the RA number, as soon as we have received all of the required information. Customer is responsible for freight charges on returning product.
- Return shipments must comply with all applicable Shipping Regulations (IATA, DOT, ADR, etc.) and carrier requirements.

RETURN THE COMPLETED **REQUEST FOR RETURN** FORM TO YOUR NEAREST LOCATION:

#### EUROPE:

Fax: 00 39 011 9979 330  
Fax Free: 00 800 345 345 00  
Toll Free: 00 800 234 234 00

#### NORTH AMERICA:

Fax: 1 781 860 9252  
Toll Free: 800 882 7426, Option 3

#### PACIFIC RIM:

Please visit our website for individual office information

[vpt-customer@agilent.com](mailto:vpt-customer@agilent.com)

[vpl-ra@agilent.com](mailto:vpl-ra@agilent.com)

<http://www.agilent.com>



**TERMS AND CONDITIONS**

**Please read the terms and conditions below as they apply to all returns and are in addition to the Agilent Technologies Vacuum Product Division – Products and Services Terms of Sale.**

- Unless otherwise pre-negotiated, customer is responsible for the freight charges for the returning product. Return shipments must comply with all applicable **Shipping Regulations** (IATA, DOT, etc.) and carrier requirements.
- Agilent Technologies is not responsible for returning customer provided packaging or containers.
- Customers receiving an Advance Exchange product agree to return the defective, rebuildable part to Agilent Technologies **within 15 business days**. Failure to do so, or returning a non-rebuildable part (crashed), will result in an invoice for the non-returned/non-rebuildable part.
- Returns for credit toward the purchase of new or refurbished Products are subject to prior Agilent approval and may incur a restocking fee. Please reference the original purchase order number.
- Units returned for evaluation will be evaluated, and a quote for repair will be issued. If you choose to have the unit repaired, the cost of the evaluation will be deducted from the final repair pricing. A Purchase Order for the final repair price should be issued within 3 weeks of quotation date. Units without a Purchase Order for repair will be returned to the customer, and the evaluation fee will be invoiced.
- Products returned that have not been drained from oil will be disposed.
- A Special Cleaning fee will apply to all exposed products.
- If requesting a calibration service, units must be functionally capable of being calibrated.



## Agilent Vacuum Products Division/Sales and Service Offices

### United States

#### **Agilent Technologies**

121 Hartwell Avenue  
Lexington, MA 02421 - USA  
Ph. +1 781 861 7200  
Fax: +1 781 860 5437  
Toll-Free: +1 800 882 7426  
[vpl-customer@agilent.com](mailto:vpl-customer@agilent.com)

### Netherlands

#### **Agilent Technologies Netherlands B.V.**

Customer Contact Center  
Laan van Langerhuize 1, toren A-8  
1186 DS Amstelveen  
Tel. +31 020 547 2600  
Fax +31 020 654 5748  
[customer@agilent.com](mailto:customer@agilent.com)

### Belgium

#### **Agilent Technologies Belgium S.A./N.V.**

Customer Contact Center  
Pegasus Park  
De Kleetlaan 12A bus 12  
B-1831 Diegem  
Tel. +32 2 404 92 22  
Fax +32 2 626 46 30  
[customer@agilent.com](mailto:customer@agilent.com)

### Brazil

#### **Agilent Technologies Brasil**

Avenida Marcos Penteado de Ulhoa  
Rodrigues, 939 - 6° andar  
Castelo Branco Office Park  
Torre Jacarandá - Tamboré  
Barueri, Sao Paulo CEP: 06460-040  
Toll free: 0800 728 1405

### China

#### **Agilent Technologies (China) Co. Ltd**

No.3, Wang Jing Bei Lu, Chao Yang District  
Beijing, 100102, China  
Tel: +86 (0)10 64397888  
Fax: +86 (0)10 64392765  
Toll free: 400 8206778 (mobile)  
Toll free: 800 8206778 (landline)  
[vacuum.cnmarketing@agilent.com](mailto:vacuum.cnmarketing@agilent.com)  
[vpc-customerservice@agilent.com](mailto:vpc-customerservice@agilent.com)

### France

Agilent Technologies  
Parc Technopolis - Z.A. de Courtaboeuf  
3, avenue du Canada - CS 90263  
91978 Les Ulis cedex, France  
Tel: +33 (0) 1 64 53 61 15  
Fax: +33 (0) 1 64 53 50 01  
[vpf.sales@agilent.com](mailto:vpf.sales@agilent.com)

### Southeast Asia

#### **Agilent Technologies Sales Sdn Bhd**

Unit 201, Level 2 uptown 2,  
2 Jalan SS21/37, Damansara Uptown  
47400 Petaling Jaya, Selangor, Malaysia  
Ph. +603 7712 6181  
Fax: +603 7727 1239  
Toll free: 1 800 880 805  
[vps-customerservice@agilent.com](mailto:vps-customerservice@agilent.com)

### India (Sales)

#### **Agilent Technologies India Pvt. Ltd.**

Unit Nos 110- 116, & Part of 101 & 109  
First Floor, Splendor Forum,  
Plot No.-3, District Centre, Jasola  
New Delhi-110025  
Ph. +91 11 4623 7100  
Fax: +91 4623 7105  
Toll Free: 1 800 180 1517

### Italy

#### **Agilent Technologies Italia S.p.A.**

Via F.Ili Varian, 54  
10040 Leini, (Torino) - Italy  
Tel: +39 011 9979 111  
Fax: +39 011 9979 350  
Toll free: 00 800 234 234 00  
[vpt-customerservice@agilent.com](mailto:vpt-customerservice@agilent.com)

### Japan

#### **Agilent Technologies Japan, Ltd.**

9-1 Takakura-cho Hachioji-city,  
Tokyo, Japan  
Tel.: +81- 3-5232-1253  
Fax: +81-120-565-154  
Toll-Free: +81-120-477-111  
[jp-vvt-sales.pdl-ext@agilent.com](mailto:jp-vvt-sales.pdl-ext@agilent.com)

### Singapore

#### **Agilent Technologies Singapore Pte. Ltd.**

1 Yishun Avenue 7,  
Singapore 768923  
Tel : (65) 6215 8045  
Fax : (65) 6754 0574  
Toll free: 1 800 2762622  
[vps-customerservice@agilent.com](mailto:vps-customerservice@agilent.com)

### Korea

#### **Agilent Technologies Korea, Ltd.**

Ilshin Building 4F  
Yongsan-gu Hannam-daero  
Seoul Korea 04418  
Tel: +82 (0)2 2194 9449  
Fax: +82 (0)2 2194 9853  
Toll free: 080 222 2452  
[vpc-customerservice@agilent.com](mailto:vpc-customerservice@agilent.com)

### UK and Ireland

#### **Agilent Technologies LDA UK Limited**

Lakeside Cheadle Royal Business Park  
Cheadle, Cheshire SK8 3GR,  
United Kingdom  
Ph. +44 01865291570  
Fax +44 01865291571  
Toll free: 00 800 234 234 00  
Toll free fax: 00 800 345 345 00  
[vpt-customer@agilent.com](mailto:vpt-customer@agilent.com)

© Agilent Technologies, Inc. 2018  
07/2018

### India (Service)

Agilent Technologies India Pvt. Ltd.  
C-Block, RMZ Centennial Plot Number- 8A, 8B, 8C,  
8D,  
Doddanakundi Industrial Area, ITPL Road,  
Mahadevapura Post, Bangalore- 560048  
Ph. +91 80 40614000  
Fax: +91 80 40148991

### Taiwan

#### **Agilent Technologies Taiwan Limited**

No. 20 Gao-shuang Road, Ping-zhen Dist  
Tao-Yuan City  
32450 Taiwan, R.O.C.  
Tel: +886 3 4959004  
Toll free: 0800 018 768  
[vpw-customerservice@agilent.com](mailto:vpw-customerservice@agilent.com)

### Germany and Austria

#### **Agilent Technologies Sales & Services GmbH & Co. KG**

Lyoner Str. 20  
60 528 Frankfurt am Main  
GERMANY  
Tel: +49 69 6773 43 2230  
Fax: +49 69 6773 43 2250

### Mexico

#### **Agilent Technologies**

Concepcion Beistegui No 109  
Col Del Valle  
C.P. 03100 – Mexico, D.F.  
Tel.: +52 5 523 9465  
Fax: +52 5 523 9472

### Other Countries

#### **Agilent Technologies Italia S.p.A.**

Via F.Ili Varian, 54  
10040 Leini, (Torino) - Italy  
Tel.: +39 011 997 9111  
Fax: +39 011 997 9350  
Toll-Free: 00 800 234 234 00  
[vpt-customer@agilent.com](mailto:vpt-customer@agilent.com)

### Customer Support & Service

#### **NORTH AMERICA:**

Toll Free: 800 882 7426  
[vpl-ra@agilent.com](mailto:vpl-ra@agilent.com)  
[Lexington-service@agilent.com](mailto:Lexington-service@agilent.com)

#### **EUROPE:**

Toll Free: 00 800 234 234 00  
[vpt-customer@agilent.com](mailto:vpt-customer@agilent.com)

#### **PACIFIC RIM:**

please visit our website for individual office  
information  
<http://www.agilent.com/chem/vacuum>

#### **Worldwide Web Site, Catalog and Order On-line:**

[www.agilent.com/chem/vacuum](http://www.agilent.com/chem/vacuum)  
Representatives in most countries