

Translation of the Original Operating Instructions

Piston Vacuum Pump



XtraDry™ 150-2

XtraDry™ 250-1

Article no.: PO P01 150 ... 152

PO P01 160 ... 162

Table of Contents

	Seite
1. Safety Precautions.....	3
1.1. For Your Orientation	4
2. Understanding The Pump.....	5
2.1. Main Features	5
2.2. Differences Between The Pump Types.....	5
2.3. Delivery	5
3. Installation.....	6
3.1. Setting Up The Pump And Location	6
3.2. Connecting The Vacuum Side.....	6
3.3. Connecting The Exhaust Side.....	6
3.4. Connecting To Mains Power	7
4. Operations.....	8
4.1. Important Information	8
4.2. Switching The Pump ON And OFF	8
4.3. Operation With Gas Ballast	9
5. What To Do In The Case Of Breakdowns ?	10
6. Maintenance	11
6.1. Precautionary Measures During Maintenance Work	11
6.2. Replacing the piston seals	11
6.3. Replacing the radial shaft seal	14
7. Service	16
8. Technical Data	17
8.1. Dimensions.....	18
9. Accessories.....	19
10. Spare parts	19
10.1 Spare Parts Package	19
Declaration of Conformity (last page)	

Please note:

Current operating instructions are also available at www.pfeiffer-vacuum.net.

1. Safety Precautions

Obey all relevant safety requirements (regulations and guidelines) and adopt suitable safety measures.

☞ Read and follow all the instructions in this manual.

☞ Inform yourself regarding:

- Hazards which can be caused by the pump;
- Hazards which can arise in your system;
- Hazards which can be caused by the medium being pumped.

Use the equipment for the intended use only (for generation of vacuum).

☞ Avoid exposing any part of the body to vacuum.

☞ Adopt suitable measures to prevent any danger arising from the formation of hot surfaces or electric sparks.

☞ Obey notes on correct vacuum and electrical connections, see section "Use and operation".

☞ Make sure that the individual components are only connected, combined and operated according to their design and as indicated in the instructions for use.

☞ Observe all safety and accident prevention regulations.

☞ Check regularly that all safety requirements are being complied with.

☞ Do not carry out any unauthorized conversions or modifications on the pump.

☞ Check that mains voltage and current conform with the equipment (see rating plate).

☞ The mains connection must be subject to a safe connection to the PE.

☞ Pay attention to the condition of cable insulation.

☞ The user must take suitable precautions to prevent any formation of explosive mixtures in the expansion chamber. Mechanically generated sparks, hot surfaces or static electricity may ignite these mixtures.

☞ Adopt suitable measures to prevent the release of dangerous, explosive, corrosive or polluting fluids.

☞ Take adequate precautions to protect people from the effects of dangerous substances, wear appropriate safety clothing.

☞ Obey applicable regulations when disposing of chemicals. Take into consideration that chemicals may be polluted.

Due to the residual leak rate of the equipment, there may be an exchange of gas, albeit extremely slight, between the environment and the vacuum system.

☞ Adopt suitable measures to prevent contamination of the pumped substances or the environment.

Electronic equipment is never 100% fail-safe. This may lead to an indefinite status of the equipment. Provide protective measures against malfunction and failure.

☞ Stopping of the pump or operating a valve must not lead to a critical dangerous situation under any circumstances.

Ensure that in case of failure the pump and the vacuum system always will turn into a safe status.

☞ In the event of cracks or leaks in the manifold pumped substances might be re-leased into the environment or into the pump housing.

☞ Especially obey notes on operation, use and maintenance.

☞ Use only genuine spare parts and accessories.

☞ Otherwise safety and performance of the equipment as well as the electromagnetic compatibility of the equipment might be reduced.

☞ Ensure that maintenance is done only by suitably trained and supervised technicians.

Ensure that the maintenance technician is familiar with the safety procedures which relate to the product processed by the vacuum system and that the equipment, if necessary, is appropriately decontaminated before starting maintenance.

☞ Obey local and national safety regulations.

Before starting maintenance vent the system, isolate the pump and other components from the vacuum pump and the electrical supply and allow sufficient cooling of the pump.

☞ When returning the pump to us please note the shipping instructions in Section 7.





1.1. For Your Orientation

Instructions in the text

➔ Operating instructions: Action should be taken!

Symbols used

The following symbols are used throughout in the illustrations:

-  Vacuum flange (inlet flange)
-  Exhaust flange
-  Gas ballast valve
-  Power supply connection

Position numbers

Identical components and accessories parts have the same position numbers in all illustrations.

Pictogram Definitions



Danger of personal injury.



Danger of damage to the pump or system.



Danger of burns from touching hot parts.



Danger of an electric shock.



Important note.

Proper use

- The XtraDry may only be used for the purpose of generating vacuum.
- The piston vacuum pumps may only be used to pump dry, inert or non reactive media.

Improper Use

The following are regarded as improper:

- Uses not covered above, and, in particular:
 - Operating the pumps in areas where there is a danger of explosion.
 - The pumping of corrosive or explosive gases.
 - The pumping of gases which are contaminated with particles, dust and condensate.
 - The pumping of liquids.
 - The XtraDry may not be used for the purpose of generating pressure.
 - Connection to units which contain touchable and voltage carrying parts.
 - Connection to pumps and units which is not permitted according to their operating instructions.
 - Using accessories not named in this manual is not permitted without authorization from Pfeiffer Vacuum.
 - Operating the pump at intake pressure > 25 mbar continuously --> for N₂ and air.
 - The evacuating of inadmissibly high chamber volumes; (please see technical data)

Improper use will cause any rights regarding liability and guarantees to be forfeited.

2. Understanding The Pump

2.1. Main Features

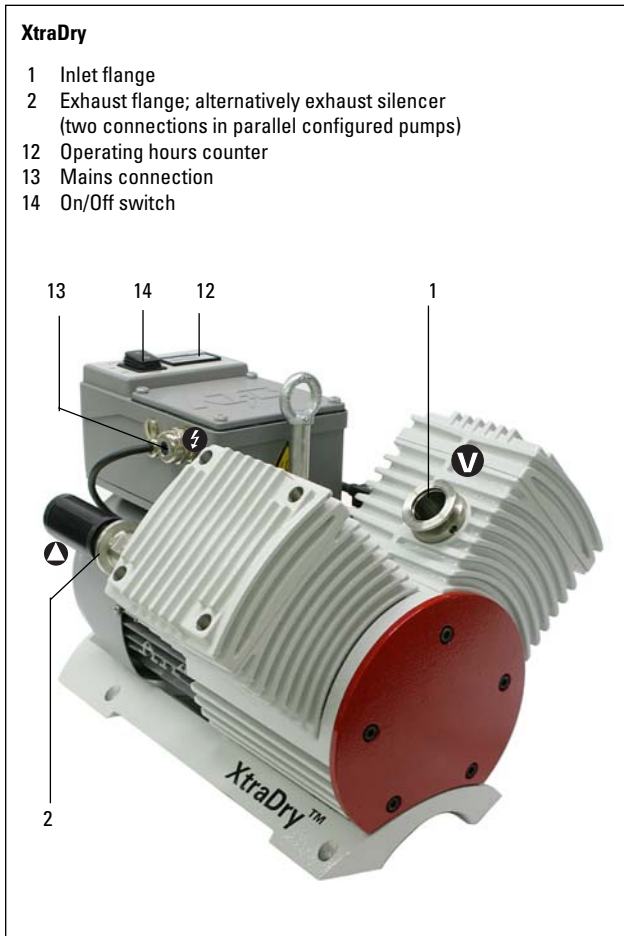

Description of pump mechanism

The XtraDry is an oil-free vacuum pump, which is based and operates on the piston principle. Each compression stage consists of a cylinder in which a piston reciprocates in a cylinder.

In the XtraDry model 150-2, two compression stages are internally connected in series. Gas coming from the inlet enters the compression space of the first piston (stage I). After compression, the now higher pressure gas enters the compression space of the second piston (stage II). Once the gas reaches a pressure slightly above atmosphere it leave the pump via a one way valve.

The XtraDry model 250-1 consists of two pistons connected in parallel which during each stroke simultaneously take gas in, compress it to atmospheric pressure and eject it to atmosphere.

2.2. Differences Between The Pump Types

Feature	XtraDry 250-1	XtraDry 150-2
Line-up of the compression spaces	parallel	series
Inlet connection (flange)	DN 25 ISO-KF	DN 25 ISO-KF
Exhaust flange with small flange	DN 25 ISO-KF twice standard	DN 25 ISO-KF single standard
exhaust silencer		
Gas ballast valve	yes	yes
Max. volume flow rate	13 m ³ /h	7,5 m ³ /h
Ultimate pressure	< 7 mbar	< 0,1 mbar
Speed control	automatically via pressure switch	

XtraDry 250-1

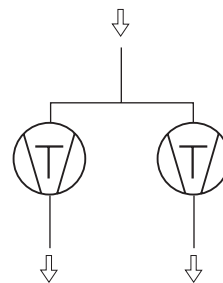

XtraDry 150-2



2.3. Delivery

- Piston Pump XtraDry 150-2/250-1
- Exhaust silencer 1/2 piece/s
- Operating Instructions

3. Installation

3.1. Setting Up The Pump And Location

Obey national safety regulations and safety requirements concerning the use of vacuum and electrical equipment.

- ➔ Remove all packing material, remove the product from its packing-box, remove the protective covers from the inlet and outlet connection and keep, inspect the equipment.
- ➔ Do not use the equipment if it is damaged.
- ➔ If the equipment is not used immediately, replace the protective covers. Store the equipment in suitable conditions.
- ➔ Read and obey this manual before installing or operating the equipment.
- ➔ When transporting, use only the eye bolt provided for the purpose.

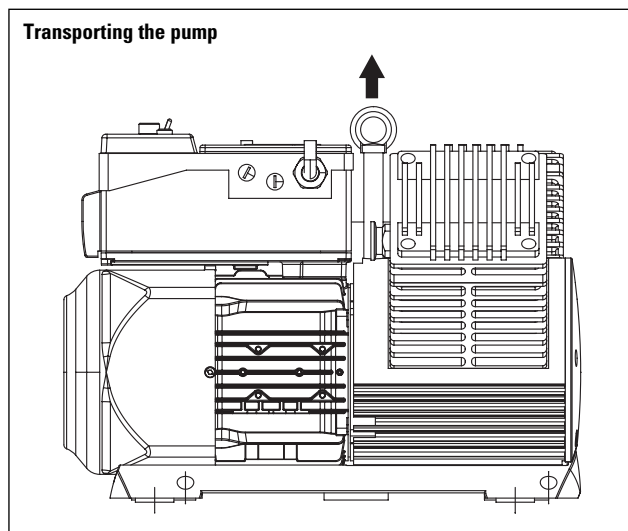

- ➔ If the equipment is brought from cold environment into a room for operation, allow the equipment to warm up (pay attention to water condensation on cold surfaces).
- ➔ Make sure ventilation is adequate if pump is installed in a housing.
- ➔ Provide a firm level platform for the equipment and check that the system to evacuated is mechanically stable and that all fittings are secure.
Attention: Flexible elements tend to shrink when evacuated.

To the best of our knowledge the equipment is in compliance with the requirements of the applicable EC-directives and harmonized standards (see "Declaration of conformity") with regard to design, type and model, especially directive IEC 1010. This directive gives in detail conditions, under which the equipment can be operated safely (see also IP degree of protection).

- ➔ Adopt suitable measures in case of differences, e. g. improve cooling measures when installation in altitudes of more than 1000 m above mean sea level.
- ➔ Ambient temperature range + 12°C (50°F) ... +40 °C (100°F).
- ➔ If the pump is to be installed in an enclosed space make sure that adequate cooling air can circulate. Maximum temperature in the enclosure cannot be above 40°C (100°F). There needs to be at least 15 cm (6 inch) between the enclosure and the motor fan.

3.2. Connecting The Vacuum Side

- ➔ Remove locking cap on intake connection 1.
- ➔ Connect pump with intake connection to the apparatus.
 - Be sure the connection between the vacuum system and the pump is flexible and as short as possible.
- ➔ Obey maximum permitted pressures and pressure differences, see section "Technical data". Do not operate the pump with overpressure at the inlet.
- ➔ To protect the pump, separators, filters and cooling traps etc.(see Section 9. Accessories) can be fitted upstream of the pump.
- ➔ The diameter of the inlet line should be at the least as large as the diameter of the pump connection.

3.3. Connecting The Exhaust Line



Pressure can rise to dangerous levels in exhaust lines. Therefore, lay exhaust lines without shut-off valves. Do not connect the exhaust line with a closed system due to the danger of bursting. In certain applications, exhaust gases and vapors can be very hot and represent a health and/or environment hazard.

- ➔ Lay exhaust lines from the pump sloping downwards so that condensate cannot run back into the pump, otherwise fit a separator.
- ➔ Do not permit any uncontrolled pressurizing (e. g. make sure that the exhaust pipeline cannot become blocked). Risk of bursting!
 - Interchanging the connections vacuum side/ exhaust line causes dangerous excess pressure levels.
- ➔ The diameter of the outlet line should be at the least as large as the diameter of the pump connection.



The pumping speed rate can be affected by the exhaust silencer.

It is better to use an exhaust line with extraction system as an alternative.

If condensable vapors are present in the exhaust, the supplied silencer can not be used. Instead, use a length of hose which will reduce the exhaust noise as well as allow the collection of the condensate.

Note: Needs 1/2 inch hose nipple to make connection.



If other pumps exhaust into this system exchange of contamination can take place.

3.4. Connecting To Mains Power

The pump is equipped with a frequency variable motor for speed control as standard:

207 ... 253 V; 50/60 Hz,
 104 ... 127 V; 50/60 Hz,
 90 ... 110 V/AC; 50/60 Hz.

- ➔ Carry out electrical connections in accordance with local regulations.
 - Voltage and frequency values on the rating plate must concur with mains voltage and mains frequency values.
 - Attach pump to mains using the protective conductor (PE) always.
 - For pumps without a power plug on the connecting cable, have the mains connection made by qualified personnel only.



Mains connection must always apply a contact to the earthed conductor, otherwise electrical voltage could occur on the pump housing.



Dangerously high voltage in the terminal box!

Before opening the terminal box disconnect the mains plug and wait for five minutes, until the intermediate circuit voltage (> 300 V) has discharged.

- ➔ Switch ON/OFF motor (pump) with release switch 14.
 - In case of an error (e.g. overheating, overcurrent, overvoltage) the electronics of the frequency converter switches off the motor automatically. If the error doesn't exist any longer, the pump restarts automatically.



Recommend fuse for mains connection:

207 ... 253 V/AC -->10 A,
 104 ... 127 V/AC -->16 A,
 90 ... 110 V/AC -->16 A.

Reset of the drive after triple occurrence

The frequency converter drive is blocked, after an error has occurred triple in quick succession.

- ➔ Disconnect the frequency converter from the mains, for

Control elements at the terminal box

- 12 Operating hours counter
- 13 Mains connection
- 14 Motor release switch

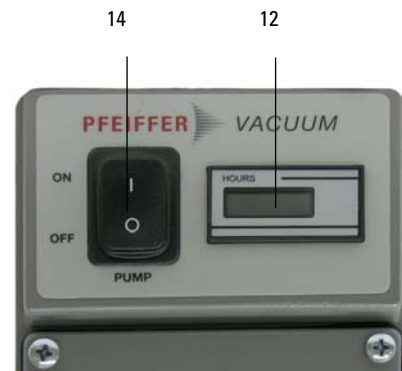

Operating panel

4. Operations

4.1. Important Information



Before starting the pump pay attention to:

- max. permissible chamber volume
- max. permissible intake pressure for continuous operation, (see Section 8.0 Technical Data).



Danger of burns!

When the pump is running, surfaces and motor casing become hot.



If the pump is subjected to condensates it should be allowed to run for approximately 30 minutes under atmospheric pressure before switching off. This will insure that the compression spaces are free of any condensables.

4.2. Switching The Pump ON And OFF

The pump can be switched on and off within the permissible intake and exhaust pressure range.

- Lowest starting temperature is +12°C (50 Deg. F).

- ➔ Switch the pump on using the built in ON/OFF switch (14).
 - The motor has a thermal protection switch which turns the motor off in case of prolonged very high load operation.
 - Please be certain to ascertain the cause of the problem and eliminate it.



After cool-down of the motor protection switch, the pump automatically starts.

Automatic speed control

The pump is equipped with a pressure switch 17 for automatic rotation speed control.

The rotation speed is reduced automatically at final vacuum to minimize the power consumption and the emission sound pressure level of the pump.

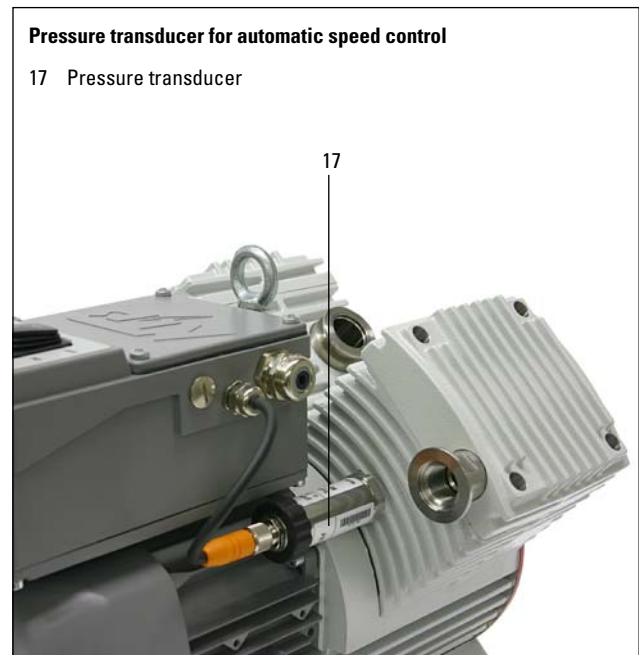

4.3. Operation with gas ballast

The XtraDry has two modes of gas ballast operation. They differ in the amount of gas admitted to the pump. At the hose connection 19 a filter is installed to prevent dust deposits in the gas ballast inlet.

Gas ballast mode (valve in position "low")

(Amount of water vapor < 1g/hour)

With gas ballast valve in position "low" the pump is flushed permanently with a small gas flow. Thus enriching of water vapour, which can condense in the pump, is avoided.

- ➔ Set the sliding sleeve 22 on the gas ballast valve to position "low";
 - the gas ballast valve closes automatically after the pump is switched off.

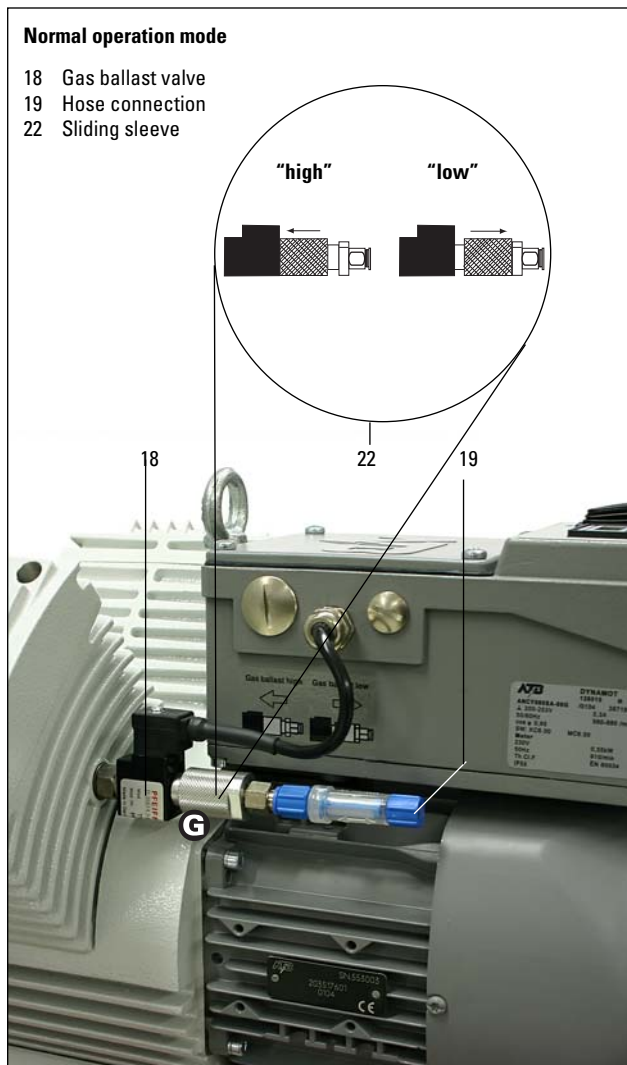

Gas ballast mode (valve in position "high")

(Amount of water vapor max. 10 g/hour)

In order to prevent water from condensing in the pump due to process with larger quantities of water it is essential to fully open the gas ballast valve. This ensures the exhaust valve opens before the condensation point of the vapor is reached.

- ➔ Set the sliding sleeve 22 on the gas ballast valve to position "high";
 - The gas ballast valve closes automatically after the pump is switched off.

It is best to use dry gas connected (e.g. nitrogen or dry air) to the ¼" (6mm) compression fitting as the ballasting gas. The gas ballast must be turned on and the ultimate pressure will increase.

- ➔ Remove gas ballast filter inserted by the factory before from the hose connection 19.



Do not exceed the inlet pressure of 0,2 bar (1,2 bar absolute) for ballasting gas.



Do not pump vapor before pump has reached its operating temperature!
Do not pump vapor with gas ballast valve closed!
Pay attention to the water vapor tolerance (see Section 8.0 Technical Data).

It is advisable to operate the pump for approximately 30 mins. with open gas ballast after process is finished. This will ensure that the pump is free of any condensables.

5. What To Do In The Case Of Breakdowns ?

Problem	Possible cause	Remedy
Pump fails to start or stops immediately.	<ul style="list-style-type: none"> ➔ Supply failure or voltage to low ➔ Pressure in outlet pipeline too high? ➔ Motor overloaded? ➔ Ambient temperature < 12 °C 	<ul style="list-style-type: none"> ☞ Check supply voltage. ☞ Remove blockade in line, open valve. ☞ Allow motor to cool, identify cause of failure. ☞ Warm pump.
Pump does not achieve final pressure or normal pumping speed	<ul style="list-style-type: none"> ➔ Long narrow line? ➔ Pump has been exposed to condensate? ➔ Outgasing substances or vapor generated in the process? ➔ Leak in system ➔ Deposits have been formed inside the pump? ➔ Pump becomes too hot ➔ Radial shaft seal damaged ➔ Worn piston seals 	<ul style="list-style-type: none"> ☞ Use line with larger diameter, length as short as possible. ☞ Run pump for a few minutes with gas ballast ("high"). ☞ Check process parameters. ☞ Repair leak ☞ Clean and inspect pump heads. ☞ Reduce pump rotation speed, ensure enough cooling or reduce input pressure. ☞ Replace radial shaft seal. ☞ Replace piston seals.
Pump stops during operation	<ul style="list-style-type: none"> ➔ Thermal overload of motor or frequency converter 	<ul style="list-style-type: none"> ☞ Check ambient temperature: --> < 40°C or insufficient air circulation for the motor fan ☞ Check supply voltage.
Pump too noisy.	<ul style="list-style-type: none"> ➔ Valves damaged ➔ Atmospheric or high pressure at inlet port ➔ Worn piston seals 	<ul style="list-style-type: none"> ☞ Replace valve plates. ☞ Connect hose to pump outlet. ☞ Replace piston seals.
Pump runs durably with max. rotation speed	<ul style="list-style-type: none"> ➔ Radial shaft seal damaged ➔ Leak in system ➔ Gas ballast valve in position "high" 	<ul style="list-style-type: none"> ☞ Replace radial shaft seal. ☞ Repair leak. ☞ Set sliding sleeve of gas ballast valve in position "low".
	<ul style="list-style-type: none"> ➔ None of above mentioned causes? 	<ul style="list-style-type: none"> ☞ Return the equipment to Pfeiffer Vacuum service.

6. Maintenance

All pump bearings are sealed and are filled with long-life hydrocarbon-free-lubricant. The piston seals and the radial shaft seal are wear parts.

Maintenance work necessarily:

1. If the rated final pressure is no longer achieved, also after flushing the pump with nitrogen.
2. High noise emission in conjunction with pressure jumps arise.



The service intervals depend on the respective field of application of the pump. Load lock operation can reduce service intervals.

Requested tools

- Set of Allen key, size: 1,5 ... 8 mm)
- Cross slot screw driver
- Torque wrench 6 Nm with insert bit, size: 5 mm
- Torque wrench 25 Nm with insert bit, size: 6/8 mm
- Torque wrench 25 Nm with wrench-size 17 mm
- Toolkit XtraDry (PO 006 001 -T)

6.1. Precautionary Measures During Maintenance Work



Whenever working on the pump ensure the pump motor is disconnected from the mains supply. If necessary, remove pump from the system for inspection. Before dismantling allow the pump to cool down.

- ➔ Only dismantle the pump as far is necessary to effect repairs.
- ➔ Use only alcohol or similar cleaning agents for cleaning. Do not use solvents.



The service intervals depend on the respective field of application of the pump. Load lock operation can reduce service intervals.

6.2. Replacing the piston seals



In order to avoid damage to the pump, do not exchange pistons, connecting rod and compensating plates after dismantling; if necessary mark the parts.

- ➔ Unscrew screws 101 and take off the housing cover 8.
- ➔ Unscrew screws 71 and take off both housing covers 6/7; be careful of O-rings 100.
- ➔ Take off the valve plates 10/11 and the spiral-type expanders 48.
- ➔ Clean piston heads with alcohol.
- ➔ Remove the connectors from the pressure transducer 17 and the gas ballast valve 18.
- ➔ Take off both cylinders 2/3; note the compensating plates 122 ... 130.



The compensating plates are required for accurate setting of the TDC timing and must be refitted in the same places during assembly of the cylinders.

- ➔ Screw on blocking tool B (PO 003 526) to block the crank web 20 using the screws of the housing cover 8.

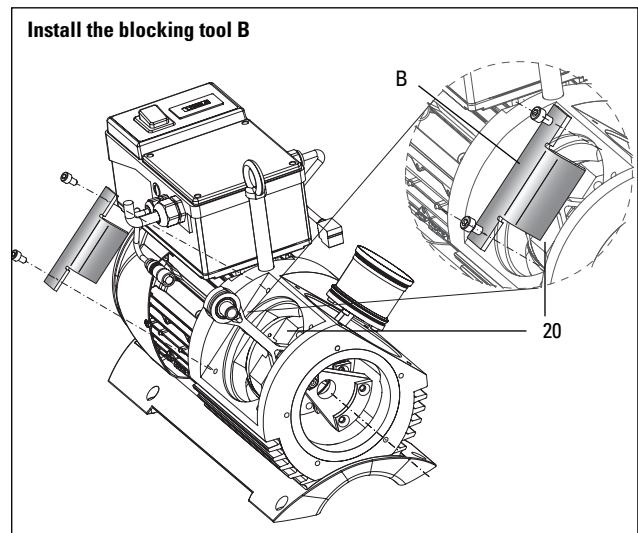

- ➔ Unscrew nut 90 from the connecting rod journal and remove centrifugal mass 25.
- ➔ Pull off the centrifugal mass 25, connecting rods 15 with pistons and spacers 27.
- ➔ Mark the position of the pistons.



The pistons must only be placed down on the piston crown.
The new piston seals must not be damaged by tools or other items with sharp edges.

- ➔ Infer piston seals from the packing only briefly before the use;
 - protect the piston seals against oil, grease and dirt.

Exploded view cylinder, pistons and connecting rod journal

- | | |
|---------------------------------------|--------------------------|
| 2 Cylinder (intake side) | 27 Spacers |
| 3 Cylinder (atmospheric side) | 48 Spiral-type expanders |
| 6 Cylinder cover (intake side) | 71 Allan head screw |
| 7 Cylinder cover (atmospheric side) | 72 Allan head screw |
| 8 Housing cover | 88 Sicherungsscheibe |
| 10 Valve plate (intake side) | 90 Nut |
| 11 Valve plate (atmospheric side) | 100 O-ring |
| 15a Connecting rod (atmospheric side) | 101 O-ring |
| 15b Connecting rod (intake side) | 122 Compensating plates |
| 18 Gas ballast valve | |
| 20 Crank web | |
| 25 Centrifugal mass | |
| 26 Connecting rod journal | |

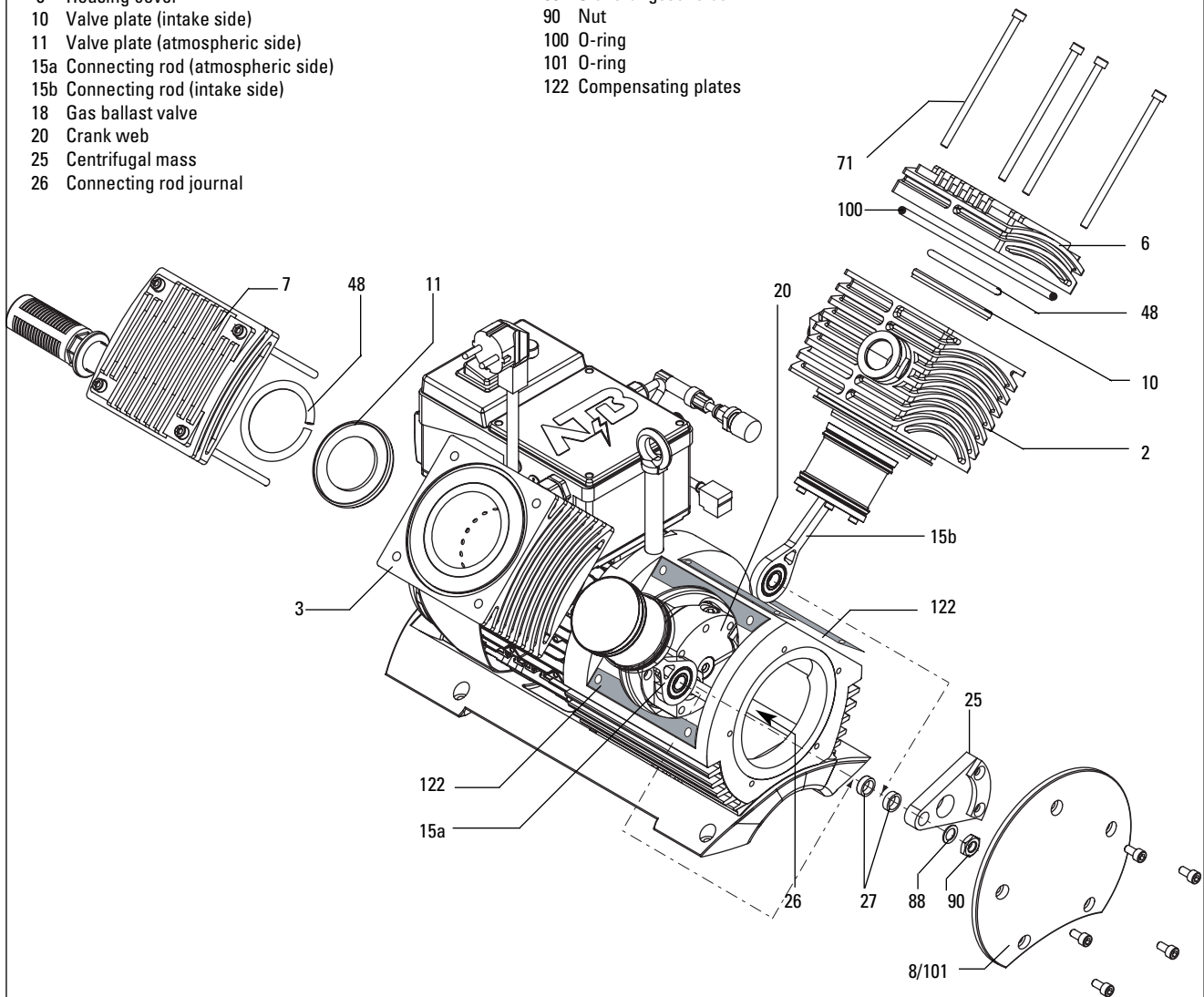

Disassembly of the piston

- ➔ Place the piston on the piston crown 30 and unscrew the Allan head screws 72 on the bottom plate of the piston 31; be careful of the lock washers 84.
- ➔ Disassemble the piston cap 31 and piston skirt 32.

Assembly

- ➔ Clean all parts; examine valve plates 10/11 and spiral-type expanders 48 for damages.
- ➔ Install new piston seals 46 between the piston head 30 and the piston skirt 32 and between the piston skirt and the piston cap 31.
- ➔ Exchange both O-rings 106 and examine and exchange if necessary piston guiding rings 34.
- ➔ Working diagonally, tighten the Allan head screws 72 up to the marking (torque of 1.3 Nm) by means of a torque wrench and screw the piston head and the piston cap together.

- ➔ Assemble both pistons, connecting rods 15 and spacers 27 onto connecting rod journal 26, observe the original position and the correct sequence.
- ➔ Slide the centrifugal mass 25 onto the connecting rod journal and tighten it finger tight with the lock washer and the hexagon nut 90.

Exploded view of piston with connecting

- 15 Connecting rod
- 30 Piston head
- 31 Piston cap
- 32 Piston skirt
- 33 Supporting ring
- 34 Piston guiding ring
- 46 Piston seals
- 72 Allan head screws
- 84 Lock washers
- 106 O-Ring

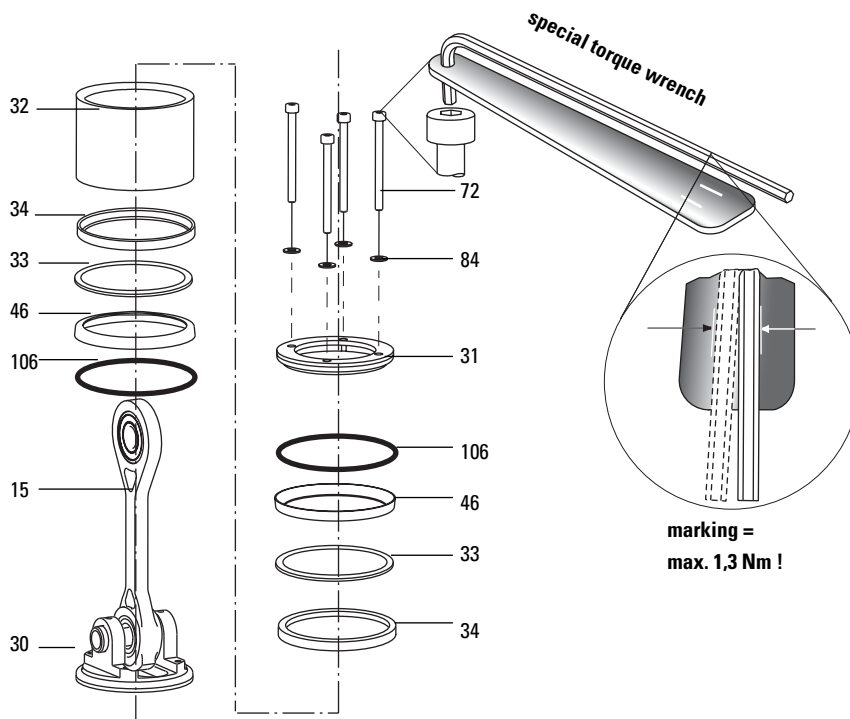

- ➔ Use the centering bolt Z (PV 040 037) to centre the centrifugal mass 25.
- ➔ Block the crank web 20 using the blocking tool B and tighten the hexagon nut 90 (jaw size 17) to a torque of 25 Nm.

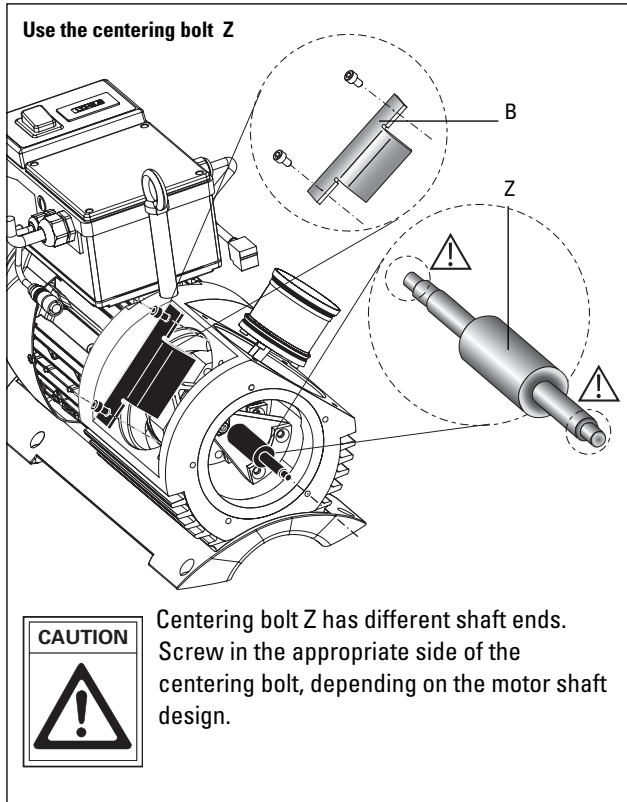

Tilting the pump 45° in each case simplifies the assembly of the compensating and valve plates.

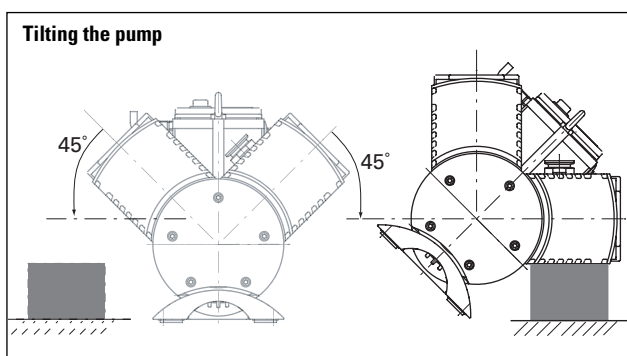

- ➔ Fit both cylinders (2/3); note the compensating plates 122 ... 130.

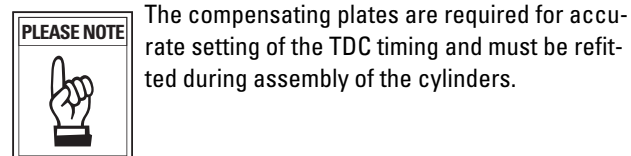

- ➔ Fit connectors to pressure transducer 17 and gas ballast valve 18.
- ➔ Install new valve plates 10/11; check that they are correctly matched and centred:
 - Plastic plate --> intake side
 - Metal plate --> atmospheric side
- ➔ Insert the spiral-type expander 48 in the annular groove; make sure that the two ends of the spiral-type expanders do not touch each other.
- ➔ Fit the cylinder covers 6/7 and, working diagonally, tighten each one with 4 Allan head screws 71 to 6 Nm; be careful of O-ring 100
- ➔ Fit and screw on the housing cover 8; be careful of O-ring 101.



Grease the threads of the screws with vacuum grease.

6.3 Replacing the radial shaft seal

Carry out the preliminary steps described in section 6.2:

- ➔ Disassemble the centrifugal mass 25, connecting rods 15 and spacers 27.

Dismantling

- ➔ Loosen the screws of the balancing weight 21 from the crankweb 20 to disable the clamping effect of the crankweb.
- ➔ Loosen the crank web 20 using the screw 70.
- ➔ Unscrew and remove blocking tool B and take off crankweb 20.

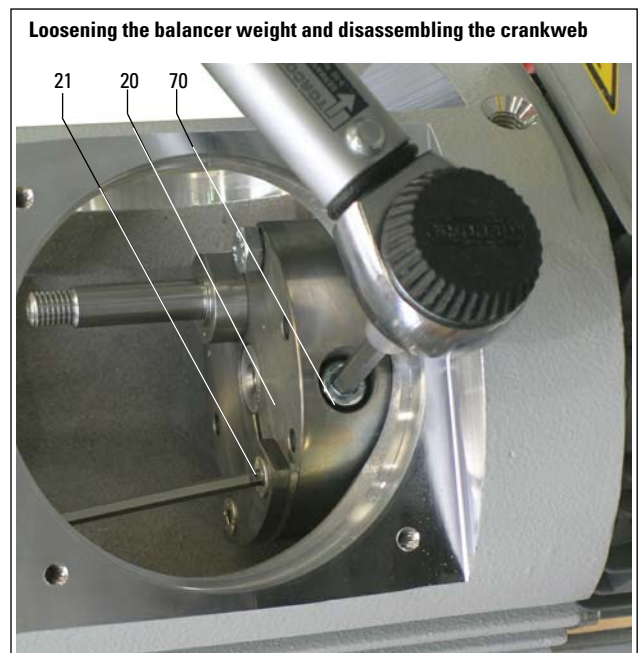

- ➔ Loosen the three screws on the shaft feedthrough 41 and remove the shaft feedthrough by hand from the housing.

Disassembly of the shaft feedthrough



- ➔ Disassemble the shaft feedthrough 40/41 in order to install a new radial shaft seal 56; to do this you will need to undo the screws 81.

Assembly

- ➔ Clean shaft feedthrough 40/41 with alcohol.
- ➔ Replace the vacuum grease for lubrication of the radial shaft seal in the annular groove.
- ➔ Insert radial shaft seal 56 (mounted on a transportation bush T) in aluminium disc 40 and insert O-ring 103.

Dismantling the shaft feedthrough 40/41 and replacing the radial shaft seal 56

- 40 Aluminium disc of shaft feedthrough
- 41 Aluminium disc of shaft feedthrough
- 55 Protective sleeve
- 56 Radial shaft seal
- 81 Countersunk screw
- 103 O-ring
- 106.1 O-ring
- T Transportation bush

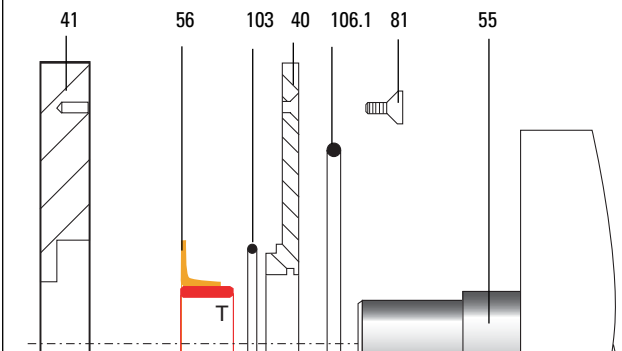

- ➔ Screw down parts 40 and 41 using countersunk screws (tightening torque: 2.8 Nm).
- ➔ Insert O-ring 106.1.

Applying fresh grease with a syringe

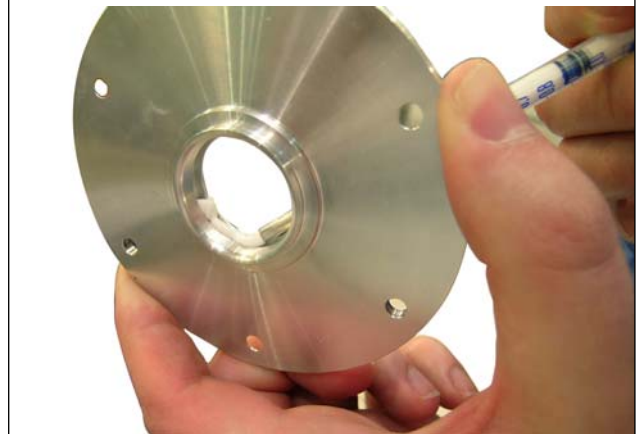

- ➔ Slightly grease the running surface of the protective sleeve.



Risk of damaging the sealing edge of the radial shaft seal 56!

- ➔ Slide the shaft feedthrough onto the end of the shaft until the stop is reached; remove the transportation bush T.
- ➔ Attach the shaft feedthrough to the housing using 3 screws and tighten the screws finger tight.
- ➔ Slide on the crank web 20 and draw it axially onto the shaft, using the disc S and the Allan head screw Z and working through the shaft feedthrough; tightening torque: 6 Nm.

Assembly of the crank web 20 and balancing weight 21

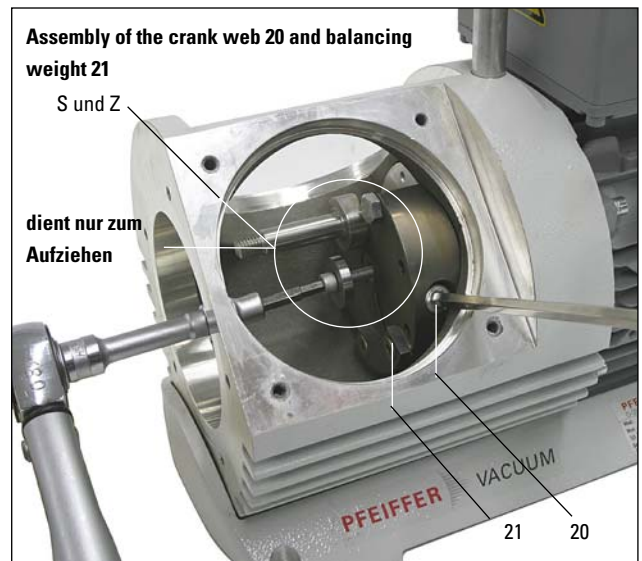

- ➔ Tighten the clamping bolt of the crank web 20 to 25 Nm.
- ➔ Loosen the Allan head screw Z and disc S again and remove them.
- ➔ Tighten the balancing weight 21; tightening torque: 8 Nm
- ➔ Install the connecting rods as described in section 6.2.

7. Service

Do Make Use Of Our Service Facilities

In the event that repairs are necessary to your pump or pumping station, a number of options are available to you to ensure any system down time is kept to a minimum:

- Have the pump repaired on the spot by our Pfeiffer Vacuum Service Engineers;
- Return the individual components to the manufacturer for repairs;
- Replace individual components with a new value exchange units.

Local Pfeiffer Vacuum representatives can provide full details.

Before Returning:

- ➔ Dismantle all accessories.
- ➔ Attach a clearly visible notice: "Free of contamination" (to the unit being returned, the delivery note and accompanying paperwork).

Harmful substances" are substances and preparations as defined in current legislation. Pfeiffer Vacuum will carry out the decontamination and invoice this work to you if you have not attached this note. This also applies where the operator does not have the facilities to carry out the decontamination work. Units which are contaminated microbiologically, explosively or radioactively cannot be accepted as a matter of principle.

Fill out the service request and the declaration on contamination

- ➔ Download the forms "Service Request" and "Declaration on Contamination".¹⁾
- ➔ Fill out the "Service Request" form and send it by fax or e-mail to your Pfeiffer Vacuum service address.
- ➔ Include the confirmation on the service request from Pfeiffer Vacuum with your shipment.
- ➔ Fill out the contamination declaration and enclose it in the shipment (required!).

Please get in touch with your local Pfeiffer Vacuum representatives if there are any questions regarding contamination.



Decontaminate units before returning or possible disposal. Do not return any units which are microbiologically, explosively or radioactively contaminated.

Returning Contaminated Units

If contaminated units have to be returned for maintenance/repair, the following instructions concerning shipping must be followed without fail:

- ➔ Neutralise the pump by flushing with nitrogen or dry air.
- ➔ Seal all openings to the air.
- ➔ Seal pump or unit in suitable protective foil.
- ➔ Ship units only in appropriate transport containers.



Repair orders are carried out according to our general conditions of sale and supply.

- ➔ If repairs are necessary, please send the unit together with a short damage description to your nearest Pfeiffer Vacuum Service Center.

8. Technical Data

Size	Unit	XtraDry 250-1	XtraDry 150-2
Connections			
Vacuum flange		DN 25 ISO-KF	DN 25 ISO-KF
Exhaust flange		DN 25 ISO-KF exhaust silencer alternatively	DN 25 ISO-KF exhaust silencer alternatively
Pumping speed at 1000 mbar	m ³ /h	13	7.5
Final pressure without gas ballast	mbar	≤ 7	≤ 0.1
Final pressure with gas ballast	mbar	20	≤ 0,2
Max. permissible intake pressure	mbar	1000	1000
Max. permissible intake pressure for continuous operation	mbar	< 25	< 25
Max. permissible chamber volume for cyclic applications		hourly or more often < 10 l daily or less frequent < 30 l	hourly or more often < 10 l daily or less frequent < 30 l
Permissible exhaust pressure	mbar	≤ 1100	≤ 1100
Rotation speed	min ⁻¹	620 / 950	620 / 950
Water vapor tolerance	mbar	2	2
Water vapor acceptable capacity	g/h	20	10
Leak rate	mbar l/s	≤ 1 • 10 ⁻²	≤ 1 • 10 ⁻²
Max. operating altitude (a. s. l)	m	2000	2000
Ambient permissible temperature range	°C °F	+12 ... +40 50°F ... 100°F	+12 ... +40 50°F ... 100°F
Noise level	dB(A)	< 65	< 65
Motor power supply			
50/60 Hz (Europa)	V/AC	207 ... 253	207 ... 253
50/60 Hz (USA)	V/AC	103 ... 126	103 ... 126
50/60 Hz (Japan)	V/AC	90 ... 110	90 ... 110
Nominal motor power	W	550	550
Max. input current at nominal voltage			
230 V	A	6	6
115 V	A	11	11
100 V	A	11,5	11,5
Motor protection		IP 32	IP 32
Weight, approx.	kg	30	30

8.1. Dimensions

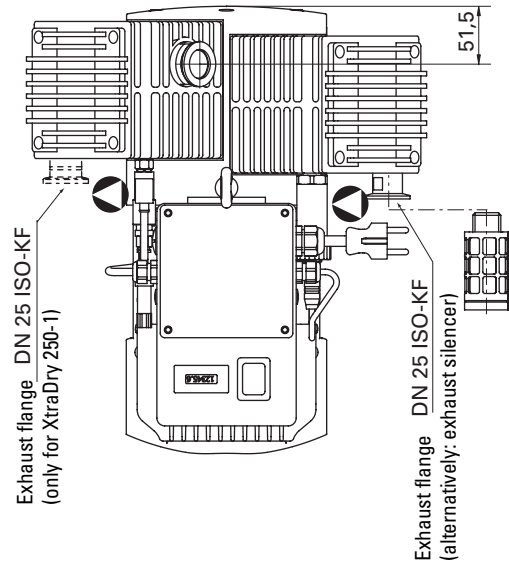
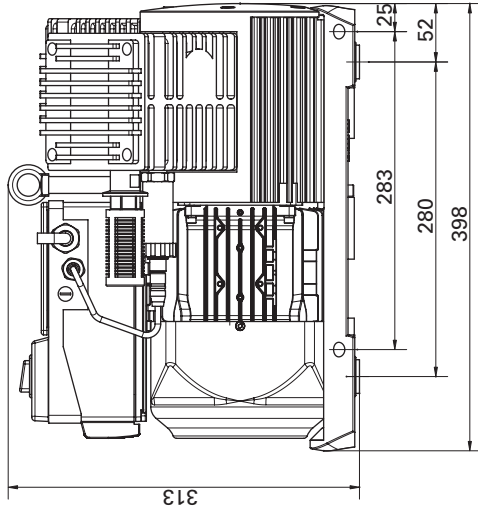
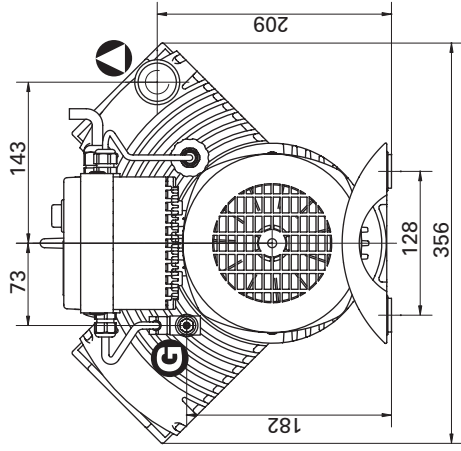
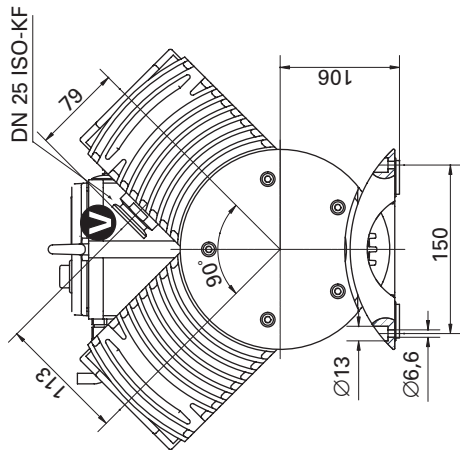

9. Accessories

Description	Size	Number	Comments/ Operating Instructions	Order Quantity
Dust separator	STP 025	PK Z60 206	PK 0120 BN	
Cooling trap	KLF 025	PK Z80 006	PD 0015 BN	
Elbow, 45°	DN 25 ISO-KF	PF 125 225 -X		

When ordering accessories please be sure to state the full part number. Please use this list as an order form (by taking a copy).

10. Spare parts

Description	Number
Silencer	PU E37 000 -T
Gas ballast filter	PO 003 448

10.1 Spare parts package

Spare parts package	Type	No.	Consisting of the following parts
Maintenance kit, Basic (Piston seals)	XtraDry 150-2 / XtraDry 250-1	PU E31 002 -T	46, 100, 101, 106
Maintenance kit, Plus (Radial shaft seal)	XtraDry 150-2 / XtraDry 250-1	PU E31 003 -T	56, 103, 106.1, PO 003 540 (grease syringe)
Toolkit, XtraDry	XtraDry 150-2 / XtraDry 250-1	PO 006 001 -T	Torque wrench (special version), blocking tool, centering bolt and Allan head screw with disc



Declaration of conformity

according to the EC directive:

- Machinery 2006/42/EC (Annex II, no. 1 A)

We hereby declare that the product cited below satisfies all relevant provisions of EC directive "Machinery" **2006/42/EC**.

In addition, the product cited below satisfies all relevant provisions of EC directive "Electromagnetic Compatibility" **2004/108/EC**.

The agent responsible for compiling the technical documentation is Mr. Sebastian Oberbeck, Pfeiffer Vacuum GmbH, Berliner Straße 43, 35614 Asslar.

XtraDry 150-2

XtraDry 250-1

Guidelines, harmonised standards and national standards and specifications which have been applied:

DIN EN ISO 12100-1 : 2004	DIN EN ISO 12100-2 : 2004	EN 55014 : 1993	EN 55022 B : 1998
DIN EN 1012-2 : 1996	DIN EN 61010 : 2002	EN 61000-3-3 : 1995	EN 61000-4-2 : 1995
EN 61000-4-3 : 1995	EN 61000-4-4 : 1995	EN 61000-4-5 : 1995	EN 61000-4-6 : 1996
EN 61000-4-11 : 1994	DIN EN ISO 13857 : 2008	DIN EN ISO 14121-1 : 2007	DIN EN 61000-6-1 : 2007
DIN EN 61000-6-2 : 2006	DIN EN 61000-6-3 : 2007	DIN EN 61000-6-4 : 2007	

Signatures:

Pfeiffer Vacuum GmbH
Berliner Straße 43
35614 Asslar
Germany

(M. Bender)
Geschäftsführer
Managing Director

(Dr. M. Wiemer)
Geschäftsführer
Managing Director

CE/2010

Vacuum is nothing, but everything to us!



Turbopumps



Rotary vane pumps



Roots pumps



Dry compressing pumps



Leak detectors



Valves



Components and feedthroughs



Vacuum measurement



Gas analysis



System engineering



Service

PFEIFFER  **VACUUM**

Pfeiffer Vacuum Technology AG · Headquarters/Germany

Tel. +49-(0) 64 41-8 02-0 · Fax +49-(0) 64 41-8 02-2 02 · info@pfeiffer-vacuum.de · www.pfeiffer-vacuum.net