

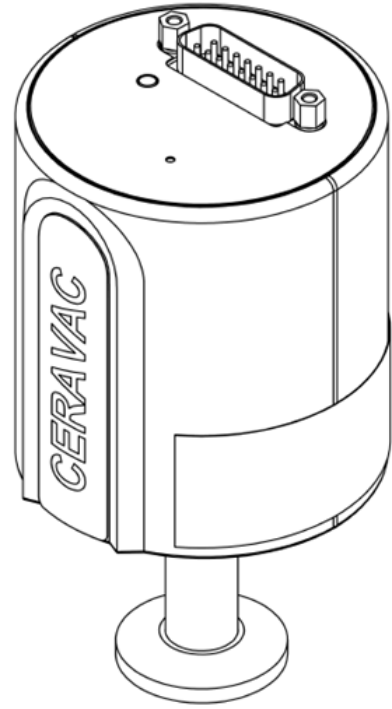

# CERAVAC® Transmitter CTR 100 N



**Operating Manual 300544660\_002\_C1**

## **Part Numbers:**

230300V02  
230301V02  
230302V02  
230303V02  
230304V02  
230305V02  
230306V02  
230307V02  
230308V02  
230309V02  
230310V02  
230311V02  
230312V02  
230313V02  
230314V02  
230315V02  
230316V02  
230317V02  
230318V02  
230319V02  
230340V02

# Contents

<b>0</b>	<b>Safety Information</b>	<b>3</b>
0.1	Symbols used	3
0.2	Personnel Qualifications	3
0.3	General safety information	3
0.4	Liability and Warranty	5
<b>1</b>	<b>Unpacking</b>	<b>6</b>
<b>2</b>	<b>Description</b>	<b>7</b>
2.1	Technical Data	8
2.2	Available Configurations	9
2.3	Accessories	9
2.4	Dimensions	10
<b>3</b>	<b>Transmitter Installation (Mechanical)</b>	<b>10</b>
3.1	Conforming utilization	11
3.2	Non-conforming utilization	11
3.3	Process Compatibility	11
<b>4</b>	<b>Transmitter Installation (Electrical)</b>	<b>14</b>
4.1	Input/Output Wiring	14
4.2	Electrical Connection Schematic	14
<b>5</b>	<b>Operations</b>	<b>16</b>
5.1	Pressure Output	16
5.2	Analog Output	17
<b>6</b>	<b>Functions</b>	<b>20</b>
6.1	Interface Connector	20
6.2	LED Status Indicator	20
6.3	Vacuum Zero Adjustment	20
<b>7</b>	<b>FAQ (Frequently Asked Questions)</b>	<b>21</b>
<b>8</b>	<b>Trouble Shooting</b>	<b>23</b>
<b>9</b>	<b>Declaration of Contamination</b>	<b>24</b>
<b>10</b>	<b>CE Declaration of Conformity</b>	<b>26</b>
<b>11</b>	<b>Notes</b>	<b>27</b>
<b>12</b>	<b>Sales and Service</b>	<b>28</b>

# 0 Safety Information

## 0.1 Symbols used

The first two symbols identify other information in this manual that is essential or useful in achieving optimal performance from the transmitter. The last symbol below is used throughout this manual to further define the safety concerns associated with the product.



### Critical

Failure to read message could result in damage to the equipment.



### Attention

Calls attention to important procedures, practices, or conditions.



### Caution

Refer to manual. Failure to read message could result in personal injury or serious damage to the equipment or both.

## 0.2 Personnel Qualifications



### Skilled personnel

All work described in this document may only be carried out by persons who have suitable technical training and the necessary experience or who have been instructed by the end-user of the product.

## 0.3 General safety information

The safety instructions should always be followed during installation and operation of the transmitter.

Pass safety information to all users.

- Adhere to the applicable regulations and take the necessary precautions for the process media used. Consider possible reactions between the materials and the process media. Consider possible reactions (e.g. explosion) of the process media due to the heat generated by the product.
- Adhere to the applicable regulations and take the necessary precautions for all work you are going to do and consider the safety instructions in this document.
- Before beginning to work, find out whether any vacuum components are contaminated. Adhere to the relevant regulations and take the necessary precautions when handling contaminated parts.

### Safety Precautions:



### Critical



**Explosive Environments.** Do not use the transmitter in presence of flammable gases or other explosive environments.

**Corrosive Environments.** The transmitter is intended for extended use in corrosive environments. Refer to Chapter 3 Section 3.3.

 **Critical**



**Service and Repair.** Do not install substituted parts or perform any unauthorized modification to the instrument. Return the instrument to a Leybold Calibration and Service Center for service to ensure all of the safety features are maintained.

 **Critical**



**DANGER: Contaminated Parts**

Contaminated parts can be detrimental to health and the environment. Before beginning to work, find out whether any parts are contaminated. Adhere to the relevant regulations and take the necessary precautions when handling contaminated parts.

 **Critical**



**DANGER: Overpressure in the vacuum system  $2.5 \text{ bar} < p < 5 \text{ bar}$**

KF flange connections with elastomer seals (e.g. O-rings) cannot withstand pressure  $< 2.5 \text{ bar}$ . Process median can thus leak and possibly damage your health.

 **Critical**



**Safe Inlet Pressures.** Never operate at pressures higher than the rated maximum pressure (refer to maximum allowable pressure from Technical Data Chapter 2 section 2.1).

 **Attention**



**CE marking** The transmitter complies with European standards for CE marking. Refer to Declaration of Conformity in Chapter 10.

 **Attention**



**Caution: vacuum component**

Dirt and damages impair the function of the vacuum component. When handling vacuum components, take appropriate measures to ensure cleanliness and prevent damages.

 **Caution**



**Caution: Purge the instrument / dirt sensitive area**

After installing the unit, or before removing it from a system, purge the unit completely with a clean, dry gas to eliminate all traces of the previously used flow material.

This instrument must be purged under a ventilation hood and suitable personal protective equipment must be worn for protection.



## Caution



**Electrical connections.** The transmitter must be properly electrically connected in order to perform according to the specifications. Output pins are not protected against wrong electrical connections. Wrong electrical connections can cause permanent damage to the transmitter or interference to measuring performance. Refer to Electrical connections in Chapter 4.

## 0.4 Liability and Warranty

Leybold assumes no liability and the warranty becomes null and void if the end-user or third parties

- disregard the information in this document
- use the product in a non-conforming manner
- make any kind of interventions (modifications, alterations etc.) on the product
- use the product with accessories not listed in the product documentation

The end-user assumes the responsibility in conjunction with the process media used. Transmitter failures due to contamination are not covered by the warranty.

# 1 Unpacking

Before unpacking your transmitter, check all surfaces of the packing material for shipping damage. Inspect for visible damage. If found, notify the carrier immediately.

Please be sure that your transmitter package contains these items:

- 1 pcs. CTR CERAVAC Transmitter
- 1 pcs. English short form manual (P/N: 300544675\_002\_C1)
- 1 pcs. German short form manual (P/N: 300544675\_001\_C1)
- 1 pcs. Product Inspection and Test Report
- 1 pcs. User switch adjustment tool

If any items are missing, please contact Leybold.



## 2 Description

The vacuum transmitter offers a four (4) decade measurement range and the measurement is based on the electrical capacitance between the diaphragm and a fixed electrode. Its output is the same regardless of the process gas composition – gas correction factors are not needed.

It can be used in a variety of applications as a stand-alone unit or with a suitable controller unit. The CTR 100 N transmitter's primary communication method is its 0 – 10 VDC analog output signal. This output can be interfaced to external analog equipment for pressure readout or control. The transmitter also has a RS232 digital communication interface for setup of transmitter parameters and to provide real time pressure measurement. Please see RS232 Instruction Manual 300544665 for further details about this interface.

### Sensor technology

The transmitter operates by measuring the electrical capacitance between a thin metal diaphragm and a patterned electrode. When the process pressure changes, the diaphragm changes its position with respect to the electrode, and that causes a change in electrical capacitance. That change in capacitance is directly proportional to the change in pressure. Because the diaphragm position is not dependent on the gas type, the transmitter provides the same output signal regardless of gas composition. The diaphragm and sensor is entirely composed of nickel alloy, which makes it resistant to damage caused by corrosion or oxidation.

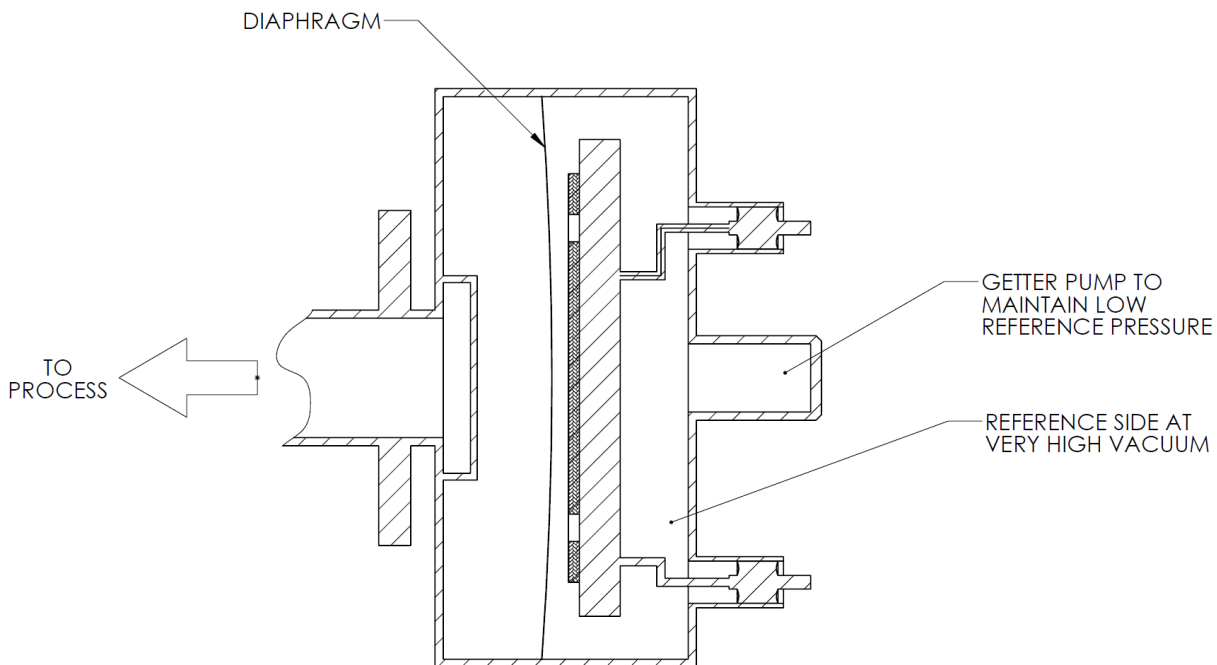

### Applications

The transmitter can be used in many different vacuum applications within the semiconductor, analytical, and coating industries:

- General vacuum pressure measurement
- Gas backfilling measurement and control
- Thin film deposition processes such as evaporation, sputtering, and chemical vapour deposition (CVD).
- Advanced materials processes, such as vacuum furnaces and ceramic sintering.
- Vacuum degassing of solvents and oils.
- Plasma and chemical cleaning.
- Analytical instruments such as electron microscopes, thermal analyzers, and mass spectrometers.

### Disposal (European Union only)

The transmitter is manufactured according to the RoHS directive.



#### Attention

For the benefit of the environment, at the end of life of the transmitter, it should not be disposed in the normal unsorted waste stream. It should be deposited at an appropriate collection point or facility to enable recovery or recycling.

## 2.1 Technical Data

Full Scale Measuring Ranges:		1000, 100, 20, 10, 1, and 0.1 Torr
Accuracy <sup>(1)</sup>		Ranges $\geq$ 1 Torr: 0.20% of reading. 0.1 Torr range: 0.50% of reading
Resolution <sup>(2)</sup>		0.003% of full scale
Supply Voltage:		+14 to + 30 VDC; nominal 24VDC; 0.030A at 24VDC
Power consumption:		< 1 Watt
Analog output:		0 – 10.00 VDC
Response Time		F.S Ranges $\geq$ 1 Torr, from 0% to 90% of F.S response time is 40ms. For 0.1Torr F.S from 0% to 90% response time is 80ms.
Sampling Rate		For transmitters with ranges > 1 Torr (1.33 mbar), the analog output signal is updated approximately 1000/sec. For transmitters with ranges $\leq$ 1 Torr (1.33 mbar), the analog output signal is updated approximately 500 times/second
Materials exposed to vacuum:		Inconel <sup>®</sup> and Incoloy <sup>®</sup> nickel alloys. KF and CF flanges are made from 300-series stainless steel.
Internal volume:	KF16 fitting CF16 fitting VCR8 fitting No fitting	6.83 cm <sup>3</sup> 6.50 cm <sup>3</sup> 6.05 cm <sup>3</sup> 6.29 cm <sup>3</sup>
Housing material:		ABS plastic, UL 94 V-0 rated, plated
Fitting material:		Incoloy <sup>®</sup> (VCR fitting) or 300-series stainless steel (KF and CF fittings)
Weight:	KF16 fitting CF 16 fitting VCR8 fitting No fitting	550 g 548 g 579 g 513 g
Operating temperature:		0° to 50° C (32° to 122° F)
Bake out temperature (Power off, fitting only):		50° C (122° F)
Humidity:		25 – 95% Relative Humidity, non-condensing
Zero Temperature Coefficient:		Ranges $\geq$ 10 Torr – 0.005% (50 ppm) full scale/°C 1 Torr – 0.015% (150 ppm) full scale/°C 0.1 Torr – 0.020% (200 ppm) full scale/°C
Span Temperature Coefficient:		Ranges $\geq$ 1 Torr - 0.01% of reading/°C 0.1 Torr – 0.03% of reading/°C
Burst pressure		5 times full scale or 90 psia, whichever is greater.
Overpressure Limit Without Damage		45 psia

(1) Accuracy specification includes non-linearity, hysteresis, and non-repeatability.

(2) Resolution specification is best obtainable under ideal laboratory conditions. Actual resolution in service may vary.

(3) The transmitter's electronics are not sealed against entry of dust, rain, or snow, and therefore can be damaged by use outdoors

## 2.2 Available Configurations

Part number	Flange	Full-Scale Measurement Range		
		Torr	KiloPascal (kPa)	mbar
230 300V02	DN 16 ISO-KF	1000	133.32	1333.2
230 301V02	DN 16 ISO-KF	100	13.332	133.32
230 340V02	DN 16 ISO-KF	20	2.666	26.66
230 302V02	DN 16 ISO-KF	10	1.333	13.33
230 303V02	DN 16 ISO-KF	1	0.133	1.33
230 304V02	DN 16 ISO-KF	0.1	0.013	0.13
230 305V02	DN 16 CF-R	1000	133.32	1333.2
230 306V02	DN 16 CF-R	100	13.332	133.32
230 307V02	DN 16 CF-R	10	1.333	13.33
230 308V02	DN 16 CF-R	1	0.133	1.33
230 309V02	DN 16 CF-R	0.1	0.013	0.13
230 310V02	8 female VCR	1000	133.32	1333.2
230 311V02	8 female VCR	100	13.332	133.32
230 312V02	8 female VCR	10	1.333	13.33
230 313V02	8 female VCR	1	0.133	1.33
230 314V02	8 female VCR	0.1	0.013	0.13
230 315V02	1/2" Tube	1000	133.32	1333.2
230 316V02	1/2" Tube	100	13.332	133.32
230 317V02	1/2" Tube	10	1.333	13.33
230 318V02	1/2" Tube	1	0.133	1.33
230 319V02	1/2" Tube	0.1	0.013	0.13

## 2.3 Accessories

Part	Part no.
Graphix One	230680V01
Graphix Two	230681V01
Graphix Three	230682V01
Cables Type C 5 Meter	12455
Cables Type C 10 Meter	230022
Cables Type C 15 Meter	12456
Cables Type C 20 Meter	12457
Cables Type C 30 Meter	12458

## 2.4 Dimensions[mm]

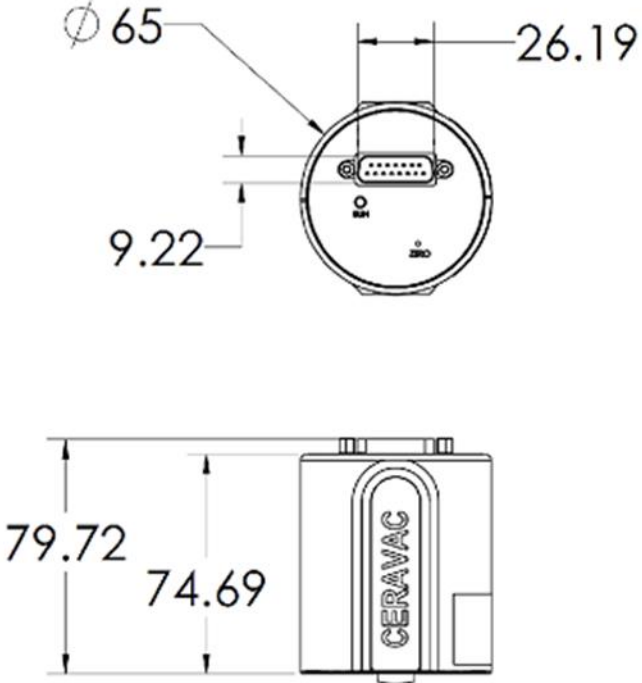
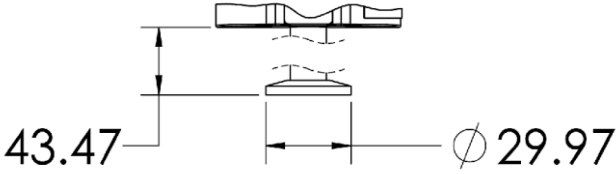
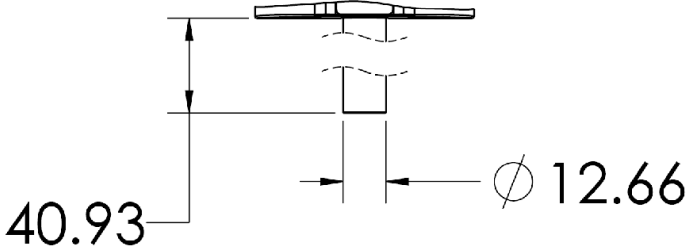
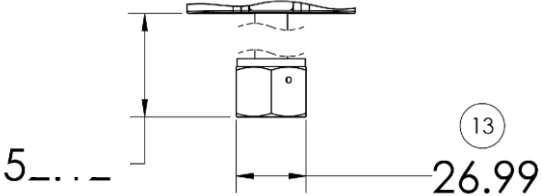
<p>P/N: 230300V02 to 230319V02, 230340V02</p>	<p>Flanges:</p>
	<p>KF 16</p> 
<p>1/2" Tube</p>	<p>CF 16</p>
	<p>8 VCR</p> 

## 3 Transmitter Installation (Mechanical)



**Caution**



**Do not use or install the transmitter where the following conditions occur:**

- Temperatures lower than 0 °C or higher than 50 °C.
- Explosive ambient environment around the transmitter.
- Direct sunlight or other heat sources, including heating, ventilation, and air conditioning outlets.
- Corrosive or condensable process gases or reaction products are likely to be present.
- Liquid condensation and/or liquid draining onto the transmitter's housing.
- Dust contamination.

### **3.1 Conforming utilization**

- The transmitter is intended for measuring pressure.
- The transmitters are intended for use in relatively clean environments.
- The transmitter can only be used by persons who have suitable technical training and the necessary experience or who have been instructed by the end-user of the product.
- Always ensure that all vacuum sealing items and surfaces are clean, without damage and free of particles.
- Use a cable with strain relief to ensure proper electrical connection and to reduce stress on the connectors.
- To comply with EN61326-1 immunity requirements, use a braided, shielded cable.

### **3.2 Non-conforming utilization**

- The transmitter cannot be used for measurements other than described in this manual.
- The transmitters are not intended for use in dirty and corrosive environments.
- Do not use the transmitter in presence of flammable gases or other explosive environments.
- Only install original parts. Do not perform any unauthorized modification to the instrument.
- The transmitter is not intended for use above maximum allowed pressure (refer Technical Data in Chapter 2).

### **3.3 Process Compatibility**

The transmitter is intended for use in non-condensing process environments. The transmitter can be used in corrosive environments (example: semiconductor processes) where aggressive gases like chlorine and fluorine are used but users should expect drift and frequent zeroing in such applications. If the transmitter is located close to a gas source connection like a flow controller or leak valve, the transmitter pressure measurement can be higher than the actual chamber pressure. Conversely, location close to a pumping system connection can cause a lower pressure measurement than actual chamber pressure.

## Mounting Orientation

The transmitter and its sensor design can be mounted in any orientation without compromising accuracy or lifetime, but operation with its inlet port facing upwards is not recommended due to the possibility of contaminants falling into the port.

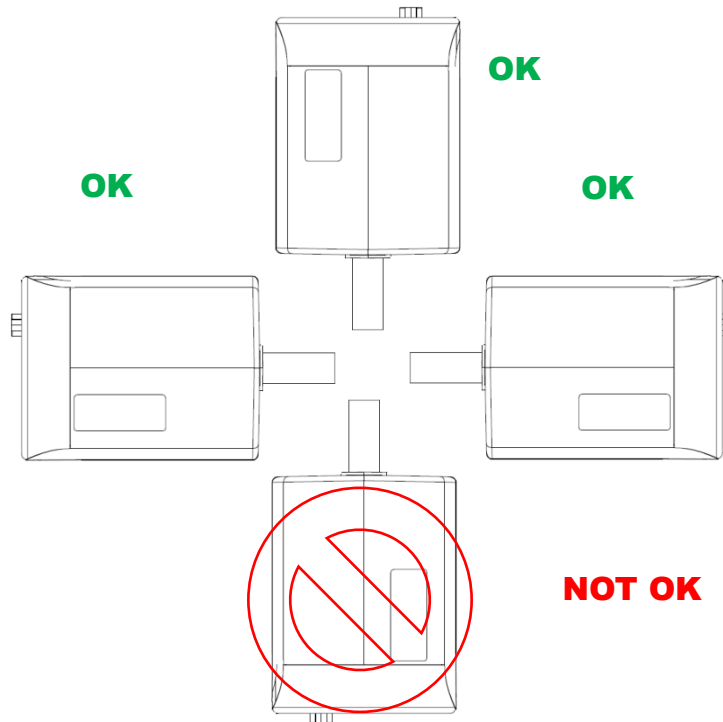

## Zero Shift From Mounting Orientation

The CTR 100 N transmitters with measurement ranges higher than 1 Torr require little or no zero adjustment if they are mounted horizontally on the customer's system. However, transmitters with ranges of 1 Torr and less require zero adjustment to compensate for the effects of gravity on the sensor diaphragm if they are mounted horizontally.

For example, for 0.1 Torr models, this shift represents up to 10% of the full-scale range, and thus is significant. Devices with this range should be mounted vertically as originally calibrated. If this mounting orientation is not possible, a correction factor must be applied to the transmitter's output to obtain the correct pressure.

## Span/ Accuracy Shift from Mounting Orientation

The CTR 100 N transmitters with measurement range 1 Torr or higher require little or no span adjustment if they are mounted horizontally on the customer's system. However, transmitters with ranges lower than 1 Torr will experience a span shift due to the effects of gravity on the sensor diaphragm if they are mounted horizontally. These transmitters would also see a degraded accuracy value.

## Explosive Environments

The sensor is kept at ambient temperature and contains no heating elements, but the steady-state electronics power draw can be up to 35 mA, which may exceed the self-ignition threshold for some gases and environments.

## Ambient Temperature

The transmitter has an active sensor temperature compensation circuit that minimizes shifts in its output caused by changes in ambient temperature. However, for best performance, avoid installation in areas where large temperature gradients and direct cooling like an air-conditioning air stream or heating like a pump exhaust stream may exist.

Operation in ambient temperatures below 0° C or above 50° C are not recommended since they may reduce the lifetime of the transmitter's electronic components.

## Bakeout

Bakeout of the entire transmitter is not recommended, as the high temperatures may damage the electronics. The transmitter's fitting only – not including the inlet tube - may be baked to 50° C.

## Contamination

As with any vacuum measurement device, locate and orient the transmitter where contamination is least likely to enter the sensor. Contamination typically causes the zero position of the transmitter to drift away from its original value, which causes the output to shift.



### Attention



If the transmitter is contaminated with a liquid like vacuum pump oil, the sensor element is likely permanently damaged. The transmitter cannot be cleaned using solvents.

## Liquid and/or Dust Entry

The transmitter's housing and electrical connector are not sealed against entry of liquids or dust, and such entry may cause damage to the electronics. Avoid mounting this product in locations where this could occur.

## Vibrations and Instant Air Inrush

The sensor can be affected by mechanical vibrations transmitted from the process chamber and piping; transmitters with ranges of 1 Torr and below are most affected by this condition. Suitable vibration damping is strongly recommended to minimize this effect.

Sudden venting to atmospheric conditions or inrush of gases will not cause sensor damage unless the gas pressure exceeds the maximum overpressure specification of the product. If the transmitter is exposed to a pressure event that exceeds the maximum overpressure specification, its sensor may experience a permanent span and calibration shift that cannot be reversed except by replacement of the sensor.

## Vacuum connections

The transmitter is available with different types of vacuum fittings. When mounting the transmitter, always ensure that all vacuum sealing items and surfaces are clean, without damage, and free of particles. Do not touch the vacuum flange sealing surface.



### Caution



If the transmitter will be exposed to pressures above atmospheric pressure, make sure that proper vacuum fittings are used. Ensure that the internal system pressure is at ambient pressure conditions before opening the vacuum system and removing any connections.

## 4 Transmitter Installation (Electrical)

Use a cable with strain relief to ensure proper electrical connection and to reduce stress on the connectors.



### Attention



Ensure a low impedance electrical connection between the transmitter body and the grounded vacuum system to shield the sensor from external electromagnetic sources.  
Ensure that the analog output is connected to floating input.

The power supply input is +14 to +30 VDC, with a nominal supply voltage of 24 VDC. Damage may occur to the circuitry if excessive voltage is applied, polarity reversed (beyond -60V), or if a wrong connection is made.

### 4.1 Input/Output Wiring

To comply with EN61326-1 immunity requirements, use a braided, shielded cable. Connect the braid to the metal hoods at both ends of the cable with the end for power supply connected to earth ground.

**I/O Connector (15 pin)**  
**15 pin male D-SUB**

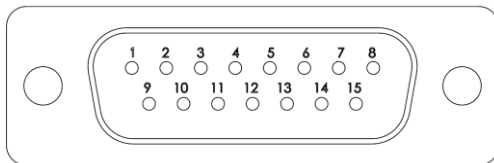

#### **PIN Description**

1	Reserved
2	Analog signal output
3	Reserved
4	Reserved
5	Power return for +24VDC supply
6	Reserved
7	+24VDC input power
8	Reserved
9	Reserved
10	Transmitter identification
11	+24VDC input power (alt)
12	Analog signal return
13	RS232, TxD
14	RS232, RxD
15	Chassis ground

### 4.2 Electrical Connection Schematic

**CTR100N Electrical Connection**

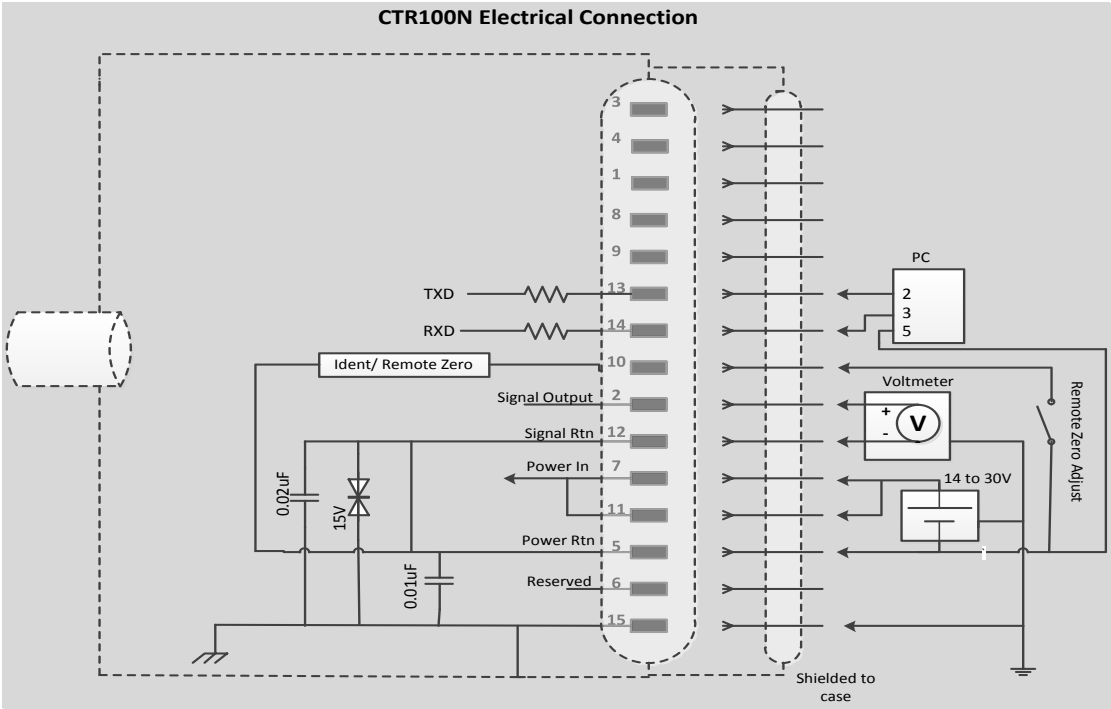

## 5 Operations

### 5.1 Pressure Output

The transmitter can provide pressure measurement output as an analog voltage value or RS232 digital value. For details about the digital interface please refer to RS232 Interface Manual 300544665 for additional information.



#### Caution



When designing external pressure control loops, make sure that external equipment like pumping system is not damaged in case of power failure.



#### Caution



When designing pressure data collecting software and control loop using data from RS232 communications, make sure that the host software does not interpret a communication error as a valid pressure value.

### Resolution

The analog pressure output can provide resolution of pressure changes as low as 0.003% of the full-scale measurement range under ideal conditions. However, in most industrial and non-metrology installations, the lowest measurable pressure will be approximately 0.01% of the full-scale range, or 1 mV. This resolution is determined by the transmitter's resident noise level, the noise and ripple occurring on the input power supply to the transmitter, shifts in ambient temperature around the transmitter, and several other factors.

### Measuring Noise

External sources can interfere with the sensor signal and cause noise on the signal. The lowest measurement ranges (below 1 Torr) are most sensitive to measuring noise due to low signal levels.

### Closed-Loop Pressure Control

The transmitter's output signal can be used as a reference for a closed-loop pressure control system. In such a system, the analog or digital output of the transmitter is sent to a dedicated controller or control element, which then compares the actual chamber pressure as read by the transmitter to an established set point. The controller then decides based on its internal programming to either open or close the pressure-controlling element(s) to raise or lower the chamber pressure to meet the set point.

Leybold recommends that the minimum control pressure using this transmitter should be 0.5% of the full-scale measurement range or 50 mV if the analog output signal is used for this control circuit. Attempting to control pressure below this minimum may result in less stable pressure control.

## 5.2 Analog Output

The transmitter can provide pressure measurement output as an analog voltage value or RS232 digital value. For details about the digital interface please refer to the RS232 Instruction Manual 300544665. The analog output is linear with pressure as shown in the graph below.

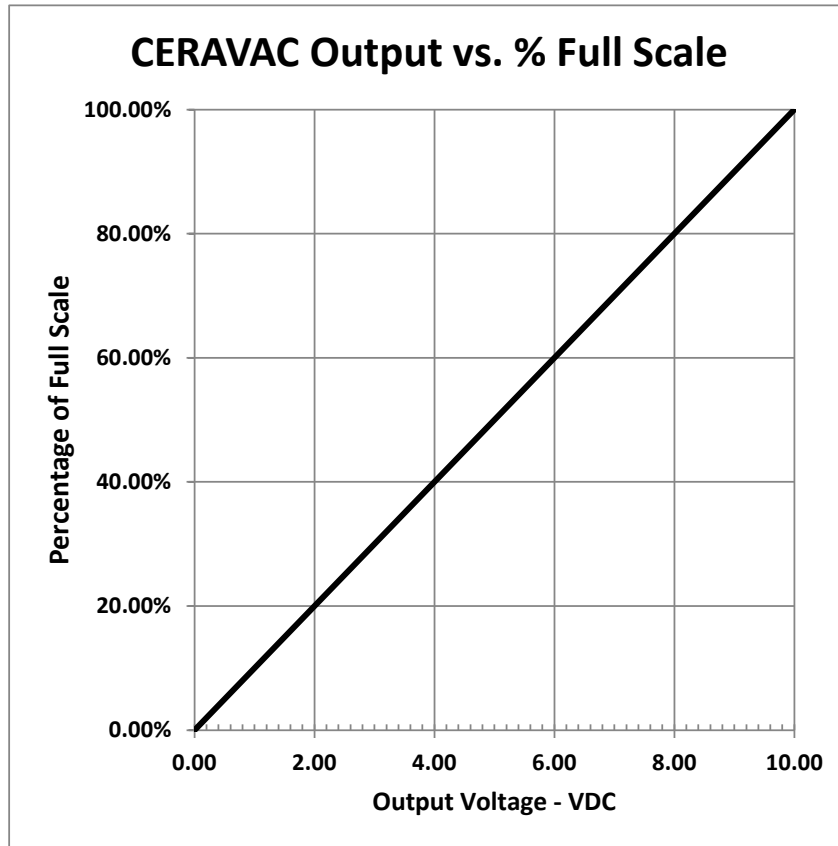

$$P \text{ (Torr)} = \frac{\text{Pressure in Volts} \times \text{Device Full Scale Range in Torr}}{10}$$

$$P \text{ (mbar)} = \frac{1.3332 \times \text{Pressure in Volts} \times \text{Device Full Scale Range in Torr}}{10}$$

$$P \text{ (Pascal)} = \frac{133.32 \times \text{Pressure in Volts} \times \text{Device Full Scale in Torr}}{10}$$

Pressure Units Conversion		
Transmitter Full-Scale Range - Torr	mbar	Pascal
0.1	0.133322	13.33224
1	1.333224	133.3224
10	13.33224	1333.224
20	26.66447	2666.447
100	133.3224	13332.24
1000	1333.224	133322.4

## Zero Adjustment

Like all precision electromechanical measuring instruments, the transmitter requires periodic zeroing of its output to provide the best possible measurement accuracy. Leybold recommends that the transmitter be zeroed upon initial installation into the user's process system to compensate for any drift that may have occurred during transportation and installation. Subsequent zeroing frequency must be determined by the user according to each application, but in general, more frequent zeroing should be expected if the transmitter is frequently exposed to atmospheric pressure, or if it is used in an application where the best measurement repeatability is needed.

To zero the transmitter, the vacuum system must be pumped down to its lowest achievable vacuum pressure, which ideally should be less than 0.01% of the transmitter's full-scale measurement range. The table below provides the recommended vacuum pressure needed for each available range.

Recommended Zeroing Pressure			
Transmitter Full-Scale Range - Torr	Torr	mbar	Pascal
1000	$\leq 0.1$	$\leq 0.132$	$\leq 13.3$
100	$\leq 0.01$	$\leq 0.013$	$\leq 1.3$
10	$\leq 1 \times 10^{-3}$	$\leq 1.3 \times 10^{-3}$	$\leq 0.13$
1	$\leq 1 \times 10^{-4}$	$\leq 1.3 \times 10^{-4}$	$\leq 0.013$
0.1	$\leq 1 \times 10^{-5}$	$\leq 1.3 \times 10^{-5}$	$\leq 1.3 \times 10^{-3}$

Once the recommended zeroing pressure has been achieved, the zero pushbutton offers multiple adjustment modes depending on the customer requirements. The first mode is to set the transducer's output to zero. **Briefly** press the ZERO button with a small diameter rod such as the User switch adjustment tool provided with each device. The transducer's output will shift to zero when this is done. The STATUS LED blinks until the adjustment is completed. However, if no action is taken within 8 seconds of entering this mode, the STATUS LED stops blinking and the transducer exits this mode.



### Caution



Use care when activating the zero pushbutton. It can be easily damaged or even knocked off its mounting on the electronics by excessive force. If this occurs, the transmitter electronics will not operate correctly.

## Zero Adjustment with RAMP Function (Please contact DAKKS Lab through email)

This function allows the user to adjust the zero to a known reference pressure within the measurement range of the transmitter. It also permits an offset of the calibration curve to either compensate for an offset in the system measurement capability, or to obtain a slightly positive zero for an analog/digital converter that requires 0 – 10 VDC input (i.e. controller does not accept negative input voltages). This offset cannot exceed 2% of the full-scale range, i.e. (+ 0.2 VDC). To use this function:

1. **Press and hold** the ZERO button with the User switch adjustment tool provided. After 5 seconds, The STATUS LED starts blinking and the zero value (starting at the current output value) will increase continually until the button is released or the maximum permitted offset (maximum of 2% the transducer's full-scale range) is reached.
  - To make additional incremental adjustments in the same direction, either press and release (for each incremental steps ) or press and hold the zero button within 3 secs after the ZERO button is released, until desired output is reached. *Note: Please allow about 1 sec for the output to settle*
  - If direction needs to be changed at any time, release the ZERO button and wait 3 to 5 sec and press again. *Suggestion: After releasing the ZERO button count the Status LED blinking to four (Status LED blinks once every sec) and press again.*
2. To return to measurement mode, **release** the ZERO button for more than 5 seconds.

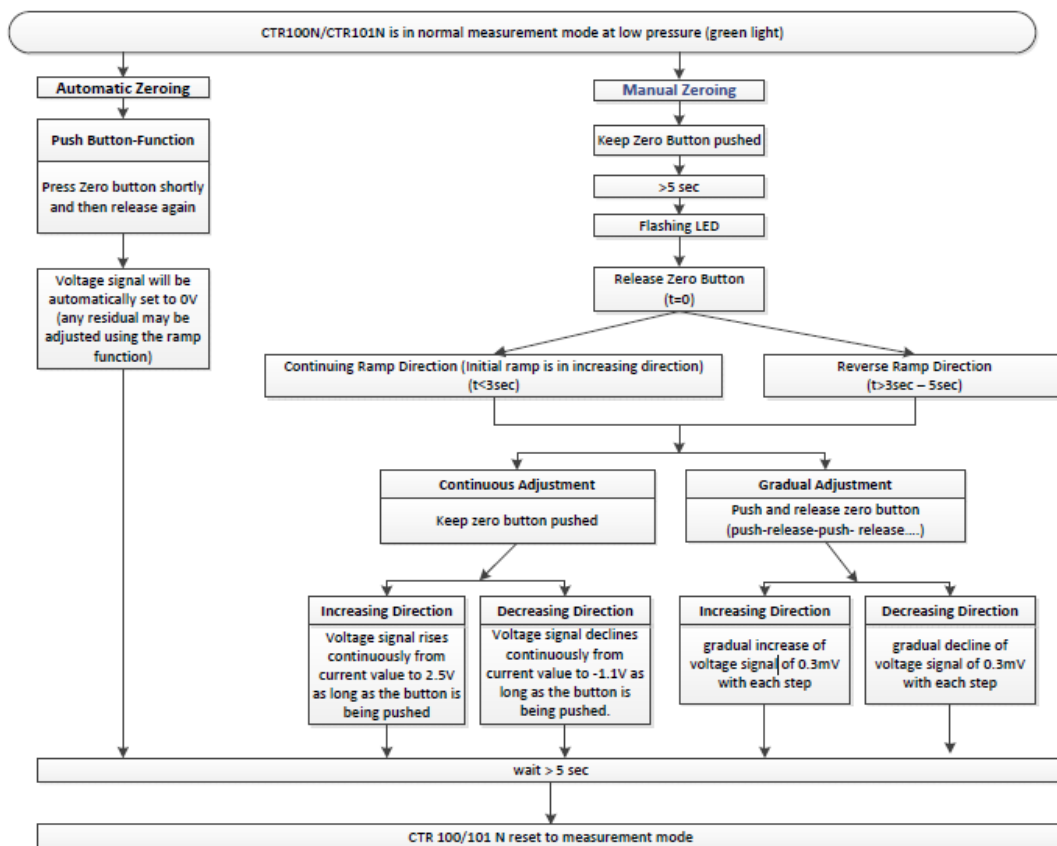

### 5.3 Transmitter Factory Default Reset

To reset all transmitter parameters, remove mains power from the device. Then press and hold the ZERO pushbutton for at least 5 seconds while reconnecting the mains power to the transmitter. This will reset all parameters in the transmitter's memory back to the original default factory settings.

## 6 Functions

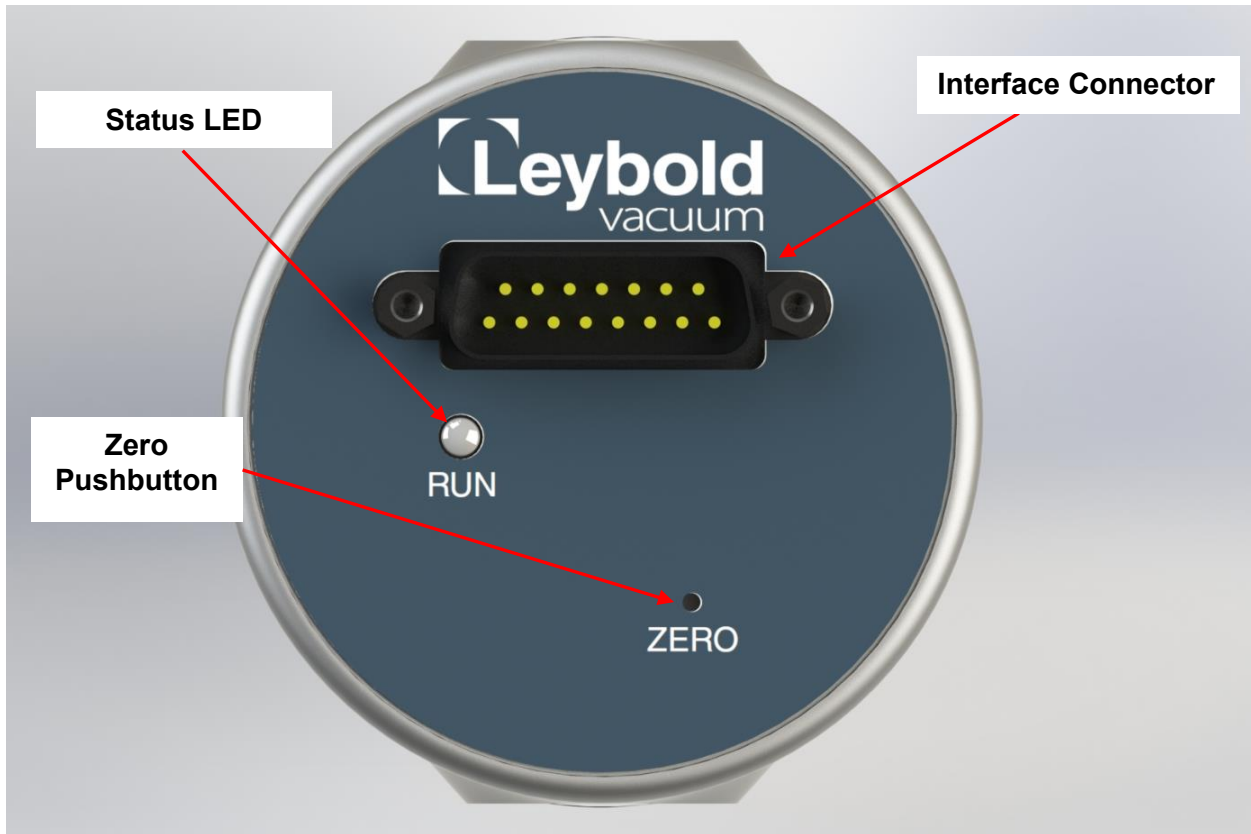

### 6.1 Interface Connector

The Interface Connector is used to connect the transmitter to mains power and to the planned display instrument. It is a standard 15-pin male D-subminiature connector, and its pin assignments are listed in Chapter 4 section 4.2. The required input power and analog output signal are described in the Chapter 2 under section 2.1 Technical Data.

### 6.2 LED Status Indicator

The green LED status indicator has the following stages:

- |                  |  |
|------------------|--|
| 1. No indication | Mains power not connected              |
| 2. Solid         | Normal operation, measurement mode     |
| 3. Blinking      | Other mode, error, or over/under-range |

### 6.3 Vacuum Zero Adjustment

The zero pushbutton is used to zero the analog and digital outputs of the transmitter. It can be used for this function at any pressure less than 20% of the transmitter's full-scale measurement range. See Chapter 5 Operations under section 5.2 for further detailed information.

## 7 FAQ (Frequently Asked Questions)

### Applications

**Q:** *Can the transmitter be used with corrosive gases?*

**A:** Yes, the transmitter uses nickel alloys exclusively in its sensor, and thus can operate in corrosive environments, but users should expect drift and frequent zeroing in such applications.

**Q:** *When the transmitter is pumped down and isolated by closing a valve, the pressure is rising. Is the transmitter leaking?*

**A:** Not likely. When a confined space is evacuated and the pumping is stopped the pressure will rise because of outgassing, mainly from water vapor desorbing from the chamber walls. The pressure can easily rise to a few Torr over time.

**Q:** *When the transmitter is leak-checked on a helium leak detector, the leak reading rises slowly after approximately 30 seconds. Is the transmitter leaking?*

**A:** No. The transmitter's sensor is fully welded and has no leak path to atmospheric pressure. However, seals in the vacuum system typically use elastomers such as Viton®, and consequently helium molecules can penetrate through the Viton and cause a slow increase of helium leak readout. If a leaking transmitter is tested directly on a helium leak detector, the leak will be displayed almost instantly.

**Q:** *Can the transmitter be mounted in any orientation?*

**A:** The transmitter can be mounted either vertically or horizontally. Transmitters with ranges lower than 1 Torr will experience a span shift due to the effects of gravity on the sensor diaphragm if they are mounted horizontally. These transmitters would also see a degraded accuracy value.

**Q:** *Can the transmitter withstand instant ventilation?*

**A:** Yes. The sensor element is extremely robust to mechanical forces and can withstand continuous pressure cycles and instant venting to atmospheric pressure. However, depending on the temperature of the ventilation, a shift in the transmitter's output may occur due to either heating or cooling effects from the airflow.

**Q:** *Can the transmitter withstand mechanical vibrations?*

**A:** Yes, but only for short periods of time. The transmitter will not suffer damage from short-term exposure to mechanical vibrations, but depending on the frequency of the vibrations, there may be some variations in the output signal due to resonance of the diaphragm.

**Q:** *How many atmospheric pressure cycles can the transmitter withstand?*

**A:** The sensor element has been tested to more than 5 million atmosphere-vacuum cycles without damage.

### Analog output

**Q:** *What is the update rate of the analog output?*

**A:** For transmitters with ranges > 1 Torr (1.33 mbar), the analog output signal is updated approximately 1000/sec. For transmitters with ranges ≤ 1 Torr (1.33 mbar), the analog output signal is updated approximately 500 times/second.

**Q:** *What is the maximum length of analog output cable?*

**A:** The length of analog cable depends on cable quality and electrical noise environment, but a cable length up to 50 m (164 ft) does normally not require any special precautions other than the cable must be shielded.

**Q:** *The digital reading is correct, but the analog output reading has some deviation from actual pressure.*

**A:** Check that the analog out is connected to a floating input and not an input that is connected to ground. If connected analog out return is connected to ground the supply current will flow in the signal line and cause voltage drop and ground looping.

## Digital output

**Q:** *How fast can I request pressure measurements via the digital interface?*

**A:** 50 times per second is the pressure report frequency.

**Q:** *How long is the waiting time from turning power on to valid measuring values?*

**A:** The power on sequence is approximately 2 seconds. The digital interface will not reply to commands sent during this period.

**Q:** *The first character is sometimes lost in the transmitter digital communication reply?*

**A:** This can be caused by too fast transmitter communication reply. See RS delay command description in the RS232 Instruction Manual part 300544665.

**Q:** *Is it necessary to use the ground wire between RS232 communication equipment and transmitter?*

**A:** Yes. RS232 communication requires a 3 wire connection between transmitter and communication equipment.

## Calibration and adjustment

**Q:** *How often does the transmitter require calibration or zero adjustment?*

**A:** Leybold recommends that the transmitter's calibration be checked against a known pressure reference approximately every 12 months. Zeroing frequency is highly dependent on the application, and users must determine this empirically. Generally, frequent exposure to atmospheric pressure and to corrosive or condensable gases will require more frequent zeroing.

**Q:** *The system's vacuum pumps cannot achieve a base pressure below the transmitter's resolution. How should the zero adjustment be used?*

**A:** When the vacuum pumps cannot reach a base pressure within the transmitter's resolution, the user must note the actual base pressure achieved prior to zeroing the transmitter. Then follow either of the two methods given below:

- Perform zeroing of the transmitter via the pushbutton, and then use the ramp function method described under **Zero Adjustment with RAMP Function** in Chapter 5 Section 5.2 to reach the base pressure.
- Perform zeroing of the transmitter via the pushbutton and then subtract the actual base pressure from all subsequent readings from the transmitter.

**Q:** *How long is the warm-up time before obtaining reliable measurements from the transmitter?*

**A:** The transmitter output is available within a few seconds of startup, but its published accuracy and performance specifications may not be met until it has been operating for 15 to 20 minutes.

**Q:** *Will the transmitter retain user calibration after power is shut off?*

**A:** Yes. All transmitter parameters are stored internally in the transmitter's non-volatile memory.

## Service and repair

**Q:** *+24 VDC supply voltage has been connected to analog output+. Is the transmitter damaged?*

**A:** Probably yes. The analog output is not protected against applying power to the output pin.

**Q:** *Reverse voltage has been connected to power supply input. Is the transmitter damaged?*

**A:** Not likely. The transmitter power supply circuit has reverse voltage and over voltage protection however, Leybold cannot guarantee that the transmitter will not be damaged.

**Q:** *Someone dropped the transmitter on the floor. Will it still operate correctly on our system?*

**A:** Not likely. The transmitter is a precision electromechanical measurement sensor, and the impact with the floor probably damaged its sensor permanently.

## 8 Trouble Shooting

Symptom	Possible Cause/Remedy
<b>No digital communication</b>	<ul style="list-style-type: none"> <li>- Check electrical connections (3 wires from transmitter to communication equipment)</li> <li>- Transmitter and communication equipment baud rate not matched.</li> <li>-</li> </ul>
<b>Incorrect or unstable pressure value</b>	<ul style="list-style-type: none"> <li>- Transducer not zeroed.</li> <li>- Contaminated sensor.</li> <li>- Corroded sensor.</li> <li>- Transmitter exposed or heating or cooling air stream.</li> </ul>
<b>Incorrect pressure value at low pressure.</b>	<ul style="list-style-type: none"> <li>- Transducer not zeroed.</li> <li>- Contaminated sensor.</li> <li>- Corroded sensor.</li> <li>- Transmitter exposed to heat or cooling air stream.</li> </ul>
<b>Incorrect pressure value at high pressure.</b>	<ul style="list-style-type: none"> <li>- Transducer not zeroed.</li> <li>- Contaminated sensor.</li> <li>- Corroded sensor.</li> <li>- Transmitter exposed to heat or cooling air stream.</li> </ul>
<b>Zero pushbutton does not work</b>	<ul style="list-style-type: none"> <li>- Pressure higher than 20% of full-scale measurement range.</li> <li>- Electronics fault.</li> <li>- Zero pushbutton is damaged (user induced).</li> </ul>
<b>No analog output</b>	<ul style="list-style-type: none"> <li>- Power supply turned off.</li> <li>- Check electrical connections.</li> </ul>

## 9 Declaration of Contamination

### Safety information on contamination of compressors, vacuum pumps and components.

Scope:

Every employer (user) is held responsible for the health and safety of his employees. This also applies to service personnel performing maintenance work either at the premises of the user or the service company in charge.

By means of the declaration attached the contractor is to be informed about any possible contamination of the compressor, vacuum pump or component sent in for servicing. Based on this information the contractor will be able to take the necessary safety precautions.

### Preparation before dispatch

Before shipping any parts, the user must complete the following declaration and add it to the dispatch papers. All dispatch instructions laid down in the manual must be followed e.g.:

- Drain all service fluids
- Remove filter elements
- Seal all openings airtight
- Pack / handle appropriately
- Attach the declaration of contamination outside of the packaging



# 10 CE Declaration of Conformity



## EU Declaration of Conformity

(Translation of original Declaration of Conformity)

**The manufacturer:** Leybold GmbH  
Bonner Strasse 498  
D-50968 Köln  
Germany

herewith declares that the products specified and listed below which we have placed on the market, comply with the applicable EU Council Directives. This declaration becomes invalid if modifications are made to the product without agreement of Leybold GmbH.

**Product designation:** CERAVAC Transmitter  
**Type designation:** CTR 100N, CTR 101N  
**Part numbers:** 230300V02, 230301V02, 230340V02, 230302V02, 230303V02,  
230304V02, 230305V02, 230306V02, 230307V02, 230308V02,  
230309V02, 230310V02, 230311V02, 230312V02, 230313V02,  
230314V02, 230315V02, 230316V02, 230317V02, 230318V02,  
230319V02, 230320V02, 230321V02, 230322V02, 230323V02,  
230324V02, 230325V02, 230326V02, 230327V02, 230328V02,  
230329V02, 230330V02, 230331V02, 230332V02, 230333V02,  
230334V02, 230335V02, 230336V02, 230337V02, 230338V02,  
230339V02

**The products complies to the following European Council Directives:**

Electromagnetic Compatibility (2014/30/EU)

**The following harmonized standards have been applied:**

EN 61326-1:2013 Electrical equipment for measurement, control and laboratory use —  
EMC requirements — Part 1: General requirements  
Emissions: Group 1, Class B  
Immunity: controlled EM environments

EN 55011:2009/A1:2010 Industrial, scientific and medical equipment — Radio-frequency  
disturbance characteristics — Limits and methods of measurement  
Group 1, Class B

**Documentation officer:** Herbert Elges  
T: +49(0)221 347 0  
F: +49(0)221 347 1250  
documentation@leybold.com

Cologne, September 01, 2016

Cologne, September 01, 2016

ppa. Martin Tollner  
VP / Head of Product Lines

ppa. Dr. Monika Mattern-Klosson  
Head of Quality & Business Process Management

Document No.: 300570957-002-A1



# 12 Sales and Service

## Germany

### Leybold GmbH

Sales, Service, Support Center (3SC)  
Bonner Strasse 498  
D-50968 Cologne  
T: +49-(0)221-347 1234  
F: +49-(0)221-347 31234  
sales@leybold.com  
www.leybold.com

### Leybold GmbH

**Sales Area North**  
Branch Office Berlin  
Industriestrasse 10b  
D-12099 Berlin  
T: +49-(0)30-435 609 0  
F: +49-(0)30-435 609 10  
sales.bn@leybold.com

### Leybold GmbH Sales Office South

Branch Office Munich  
Karl-Hammerschmidt-Strasse 34  
D-85609 Aschheim-Dornach  
T: +49-(0)89-357 33 9-10  
F: +49-(0)89-357 33 9-33  
sales.mn@leybold.com  
service.mn@leybold.com

### Leybold Dresden GmbH Service Competence Center

Zur Wetterwarte 50, Haus 304  
D-01109 Dresden  
Service:  
T: +49-(0)351-88 55 00  
F: +49-(0)351-88 55 041  
info.dr@leybold.com

## Europe

### Belgium

### Leybold Nederland B.V. Belgisch bijkantoor

Leuvensesteenweg 542-9A  
B-1930 Zaventem  
Sales:  
T: +32-2-711 00 83  
F: +32-2-720 83 38  
sales.zv@leybold.com  
Service:  
T: +32-2-711 00 82  
F: +32-2-720 83 38  
service.zv@leybold.com

### France

### Leybold France S.A.S.

Parc du Technopolis, Bâtiment Beta  
3, Avenue du Canada  
F-91940 Les Ulis cedex  
Sales and Service:  
T: +33-1-69 82 48 00  
F: +33-1-69 07 57 38  
info.ctb@leybold.com  
sales.ctb@leybold.com

### Leybold France S.A.S.

Valence Factory  
640, Rue A. Bergès  
B.P. 107  
F-26501 Bourg-lès-Valence Cedex  
T: +33-4-75 82 33 00  
F: +33-4-75 82 92 69  
marketing.vc@leybold.com

## Great Britain

### Leybold UK LTD.

Unit 9  
Silverglade Business Park  
Leatherhead Road  
Chessington  
Surrey (London)  
KT9 2QL  
Sales:  
T: +44-13-7273 7300  
F: +44-13-7273 7301  
sales.ln@leybold.com  
Service:  
T: +44-13-7273 7320  
F: +44-13-7273 7303  
service.ln@leybold.com

## Italy

### Leybold Italia S.r.l.

Via Trasimeno 8  
I-20128 Mailand  
Sales:  
T: +39-02-27 22 31  
F: +39-02-27 20 96 41  
sales.mi@leybold.com  
Service:  
T: +39-02-27 22 31  
F: +39-02-27 22 32 17  
service.mi@leybold.com

## Netherlands

### Leybold Nederland B.V.

Floridadreef 102  
NL-3565 AM Utrecht  
Sales and Service:  
T: +31-(30) 242 63 30  
F: +31-(30) 242 63 31  
sales.ut@leybold.com  
service.ut@leybold.com

## Switzerland

### Leybold Schweiz AG, Pfäffikon

Churerstrasse 120  
CH-8808 Pfäffikon  
Warehouse and shipping address:  
Riedthofstrasse 214  
CH-8105 Regensdorf  
Sales:  
T: +41-44-308 40 50  
F: +41-44-302 43 73  
sales.zh@leybold.com  
Service:  
T: +41-44-308 40 62  
F: +41-44-308 40 60  
service.zh@leybold.com

## Spain

### Leybold Spain, S.A.

C/. Huelva, 7  
E-08940 Cornellà de Llobregat  
(Barcelona)  
Sales:  
T: +34-93-666 43 11  
F: +34-93-666 43 70  
sales.ba@leybold.com  
Service:  
T: +34-93-666 46 11  
F: +34-93-685 43 70  
service.ba@leybold.com

## Headquarter

### Leybold GmbH

Bonner Strasse 498  
D-50968 Cologne  
T: +49-(0)221-347-0  
F: +49-(0)221-347-1250  
info@leybold.com

## America

## USA

### Leybold USA Inc.

5700 Mellon Road  
USA-Export, PA 15632  
T: +1-724-327-5700  
F: +1-724-325-3577  
info.ex@leybold.com  
Sales:  
T: +1-724-327-5700  
F: +1-724-333-1217  
Service:  
T: +1-724-327-5700  
F: +1-724-325-3577

## Brazil

### Leybold do Brasil

Rod. Vice-Prefeito Hermenegildo Tonolli,  
nº. 4413 - 6B  
Distrito Industrial  
Jundiá - SP  
CEP 13.213-086  
Sales and Service:  
T: +55 11 3395 3180  
F: +55 11 99467 5934  
sales.ju@leybold.com  
service.ju@leybold.com

## Asia

## P. R. China

### Leybold (Tianjin) International Trade Co. Ltd.

Beichen Economic  
Development Area (BEDA),  
No. 8 Western Shuangchen Road  
Tianjin 300400  
China  
Sales and Service:  
T: +86-22-2697 0808  
F: +86-22-2697 4061  
F: +86-22-2697 2017  
sales.tj@leybold.com  
service.tj@leybold.com

## India

### Leybold India Pvt Ltd.

No. 82(P), 4th Phase  
K.I.A.D.B. Plot  
Bommasandra Industrial Area  
Bangalore - 560 099  
India  
Sales and Service:  
T: +91-80-2783 9925  
F: +91-80-2783 9926  
sales.bg@leybold.com  
service.bg@leybold.com

## Japan

### Leybold Japan Co., Ltd.

Headquarters  
Shin-Yokohama A.K.Bldg., 4th floor  
3-23-3, Shin-Yokohama  
Kohoku-ku, Yokohama-shi  
Kanawaga 222-0033  
Japan  
Sales:  
T: +81-45-471-3330  
F: +81-45-471-3323  
sales.yh@leybold.com

### Leybold Japan Co., Ltd.

Tsukuba Technical Service Center  
1959, Kami-yokoba  
Tsukuba-shi, Ibaraki-shi 305-0854  
Japan  
Service:  
T: +81-29 839 5480  
F: +81-29 839 5485  
service.iik@leybold.com

## Malaysia

### Leybold Malaysia Leybold Singapore Pte Ltd.

No. 1 Jalan Hi-Tech 2/6  
Kulim Hi-Tech Park  
Kulim, Kedah Darul  
Aman 09000  
Malaysia  
Sales and Service:  
T: +604 4020 222  
F: +604 4020 221  
sales.ku@leybold.com  
service.ku@leybold.com

## South Korea

### Leybold Korea Ltd.

3F, Jeilzone 2 Tower  
Jeongja-dong 159-4  
Bundang-gu Sungnam-si  
Gyeonggi-do  
Bundang 463-384, Korea  
Sales:  
T: +82-31 785 1367  
F: +82-31 785 1359  
sales.bd@leybold.com  
Service:  
623-7, Upsilon-Dong  
Cheonan-Si  
Chungcheongnam-Do  
Korea 330-290  
T: +82-41 589 3035  
F: +82-41 588 0166  
service.cn@leybold.com

## Singapore

### Leybold Singapore Pte Ltd.

8 Commonwealth Lane #01-01  
Singapore 149555  
Singapore  
Sales and Service:  
T: +65-6303 7030  
F: +65-6773 0039  
sales.sg@leybold.com  
service.sg@leybold.com

## Taiwan

### Leybold Taiwan Ltd.

No 416-1, Sec. 3  
Chunghsin Rd., Chutung  
Hsinchu County 310  
Taiwan, R.O.C.  
Sales and Service:  
T: +886-3-500 1688  
F: +886-3-583 3999  
sales.hc@leybold.com  
service.hc@leybold.com



www.leybold.com