



Hepta 100/200/300 -/P

Screw Pump

Operating Instructions

Table of contents

1	About this manual	3
1.1	Validity	3
1.2	Conventions	3
2	Safety	5
2.1	Safety precautions	5
2.2	Protective equipment	5
2.3	Proper use	6
2.4	Improper use	6
3	Transport and storage	6
3.1	Transport	6
3.2	Storage	7
4	Product description	8
4.1	Product identification	8
4.2	Function	9
4.3	Range of application	11
5	Installation	12
5.1	Setting up the pump	12
5.2	Filling with lubricant	12
5.3	Connecting the cooling water	13
5.4	Connecting the vacuum side	15
5.5	Connecting the exhaust side	15
5.6	Connecting to the mains power supply	16
5.7	Connecting accessories	19
6	Operation	21
6.1	Before switching on	21
6.2	Switching on the pump	21
6.3	Switching off	22
7	Maintenance	23
7.1	Precautions	23
7.2	Changing the lubricant	25
7.3	Drain condensate in the silencer	26
7.4	Check the oil lubricated mechanical seals	26
8	Decommissioning	27
8.1	Shutting down for longer periods	27
8.2	Re-starting	27
8.3	Disposal	28
9	Malfunctions	28
9.1	Rectifying malfunctions	28
10	Service	30
11	Spare parts	31
12	Accessories	31
13	Technical data and dimensions	32
13.1	General	32
13.2	Technical data	32
13.3	Dimensions	33
	Declaration of conformity	35

1 About this manual

1.1 Validity

This operating manual is for customers of Pfeiffer Vacuum. It describes the functioning of the designated product and provides the most important information for safe use of the unit. The description follows applicable EU guidelines. All information provided in this operating manual refer to the current state of the product's development. The documentation remains valid as long as the customer does not make any changes to the product. Up-to-date operating instructions can also be downloaded from www.pfeiffer-vacuum.com.

Applicable documents

Hepta 100/200/300 -/P	Operating instructions
Declaration of Conformity	Part of this document
Operating instructions for accessories (order-specifically)	see section "accessories"

*also available via www.pfeiffer-vacuum.com

1.2 Conventions

Safety instructions

The safety instructions in Pfeiffer Vacuum operating instructions are the result of risk evaluations and hazard analyses and are oriented on international certification standards as specified by UL, CSA, ANSI Z-535, SEMI S1, ISO 3864 and DIN 4844. In this document, the following hazard levels and information are considered:

DANGER
Imminent danger Indicates an imminent hazardous situation that will result in death or serious injury.
WARNING
Possibly imminent danger Indicates an imminent hazardous situation that can result in death or serious injury.
CAUTION
Possibly imminent danger Indicates an imminent hazardous situation that can result in minor or moderate injury.
NOTICE
Command or note Command to perform an action or information about properties, the disregarding of which may result in damage to the product.

Pictograph definitions



Prohibition of an action or activity in connection with a source of danger, the disregarding of which may result in serious accidents



Warning of a displayed source of danger in connection with operation of the unit or equipment



Command to perform an action or task associated with a source of danger, the disregarding of which may result in serious accidents







Important information about the product or this document

Instructions in the text

→ Work instruction: here you have to do something.

Symbols used

The following symbols are used consistently throughout in all illustrations:

-  Vacuum flange
-  Exhaust flange
-  Gas ballast connection
-  Sealing gas connection
-  Power connection

2 Safety

2.1 Safety precautions



Duty to inform

Each person involved in the installation, operation or maintenance of the vacuum pump must read and observe the safety-related parts of these operating instructions.

→ The operator is obligated to make operating personnel aware of dangers originating from the vacuum pump, the pumped medium and the entire system.

- Do not expose any body parts to the vacuum.
- Observe the safety and accident prevention regulations.
- Check regularly that all safety precautions are being complied with.
- Do not carry out any unauthorised modifications or conversions to the pumps.
- Depending on the operating and ambient conditions, the surface temperature of the pumps may rise above 80 °C. Use suitable finger guards if necessary.
- When returning the pumps to us please note the instructions in the Service section.

2.2 Protective equipment

Determined situations concerning the handling of vacuum pumps require wearing of personal protective equipment. The owner, respectively the employer are obligated to provide adequate equipment to any operating persons.



DANGER

Danger to health by hazardous substances during maintenance or installation

Depending on the process vacuum pumps, components or operating fluids can be contaminated by toxic, reactive or radioactive substances.

→ Wear adequate protective equipment during maintenance and repairs or in case of reinstallation.



CAUTION

Risk of injury through hot surfaces

Vacuum pumps can become hot during operation.

- Allow the pump to cool before maintenance and repairs.
- If necessary wear protective gloves according to directive EN 420.



WARNING

Increased noise emission!

Increased noise emission can occur within a limited area surrounding the vacuum pump.

- Provide noise protection or
- wear hearing protection.

2.3 Proper use



NOTICE

CE conformity

The manufacturer's declaration of conformity becomes invalid if the operator modifies the original product or installs additional components.

→ Following installation into a plant and before commissioning, the operator must check the entire system for compliance with the valid EU directives and reassess it accordingly.

- The vacuum pump may only be used to generate a vacuum.
- Use sealing gas, depending on the process.
- Installation, operating and maintenance regulations must be complied with.
- Other accessories, than those described in this manual, must not be used without the agreement of Pfeiffer Vacuum.

2.4 Improper use

Improper use will cause all claims for liability and warranties to be forfeited. Improper use is defined as usage for purposes deviating from those mentioned above, especially:

- pumping of corrosive gases
- pumping of explosive media
- operation in potentially explosive areas
- operation of the pump with open vacuum or fore-vacuum flange open to the atmosphere
- use of the vacuum pump to generate pressure
- connection to pumps or units which are not suitable for this purpose according to their operating instructions
- connection to units which have exposed voltage-carrying parts
- the evacuation of gases that may form adherent deposits or condensate in the suction chamber

3 Transport and storage

3.1 Transport

The vacuum pumps are checked for functioning in the factory and packed properly on pallets. In the packaged condition, the vacuum pump can be moved with a pallet truck.



WARNING

Danger from falling and swinging loads!

When lifting the pump there is a danger of falling parts.

- Make sure that there are no persons under the suspended load.
- Close off and supervise the area under the pump.

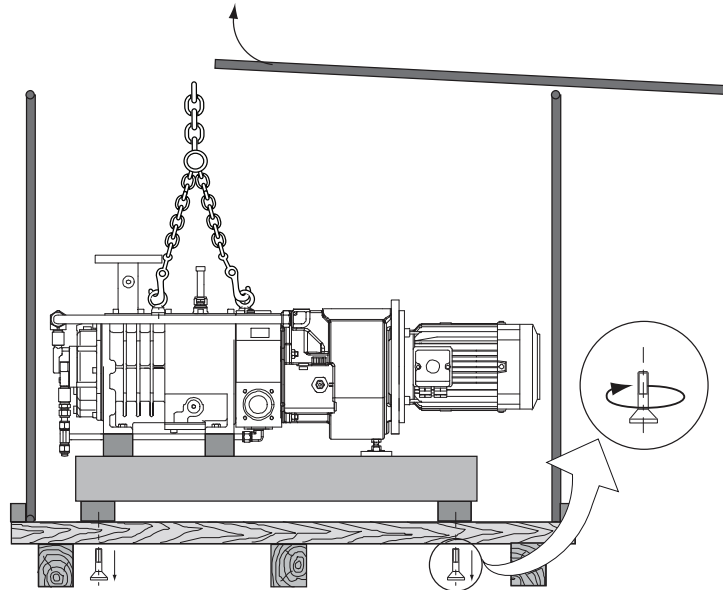

Fig. 1: Unpack and lift pump

- Look for transportation damage when receiving the pump.
- Lift the pump using lifting devices, and use only the eye bolts provided for that purpose on the top side of the pump.
- Reuse the transport container. Vacuum pumps should be transported or shipped in the original packing only.
- Remove the locking cap from the vacuum and fore-vacuum flange immediately before connecting!

3.2 Storage

The inside of the vacuum pump is protected against corrosion for only a limited time. If stored for longer than three months, the suction chamber should be preserved.

- Check that all the openings on the pump are securely closed.
- Store the pump only indoors, preferably at temperatures between -10 °C and $+40\text{ °C}$.
 - In rooms with moist or aggressive atmospheres, the pump must be airtight shrink-wrapped in a plastic bag together with a bag of desiccant.
 - After storage periods longer than two years, it is recommended to carry out maintenance and change the lubricant before using the pump.

4 Product description

4.1 Product identification

To correctly identify the product when communicating with Pfeiffer Vacuum, always have the information from the rating plate available.

- Serial number
- Pump model and model number
- Type and amount of lubricant

For motor-specific data, please see the separately installed motor rating plate.

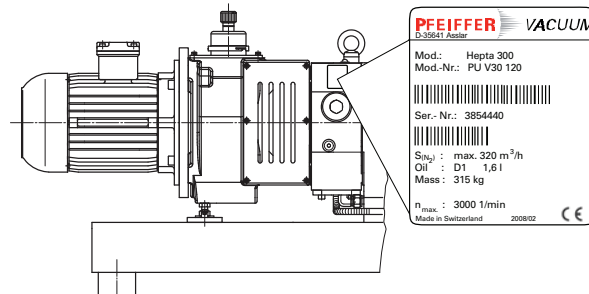

Fig. 2: Product identification on the rating plate

The product designation consists of a family designation (1), the size (2), which is oriented on the pumping speed, and if applicable the additional properties (3) of the pump.

Hepta⁽¹⁾ 100⁽²⁾P⁽³⁾

1. Family designation	2. Model designation	3. Property designation
Hepta	100 = Model designation of the pump related to its pumping speed class	none = Standard version (with oil lubricated single mechanical seals) *P = Process (alternative sealing)

*Motor side (A): Labyrinth and shaft feed through to the motor with radial shaft seal ring
Intake side (B): Labyrinth

Variants

Parameter	Hepta 100	Hepta 200	Hepta 300
Flange (in)	DN 63 ISO-K	DN 63 ISO-K	DN 63 ISO-K
Flange (out)	DN 40 PN 16	DN 50 PN 16	DN 50 PN 16

Scope of delivery

- Pump with drive unit
- Protective cover for the connection flanges
- Lubricant D1
- Silencer
- Non-return valve
- Protective strainer
- Operating instructions

4.2 Function

The screw pumps work according to the screw principle: Two parallel bearing-supported screw rotors turn in opposite direction in the cylinder. The medium to be conveyed is thus enclosed in the space between the screw rotors and the housing and is transported to the gas exhaust point, compressed and expelled by means of the turning motion. An advantage of this pump type is that it can be operated at every intake pressure between atmosphere and ultimate pressure. Due to the contact-free operation of the vacuum pump, no operating fluid, such as oil or water, are needed in the working chamber. An adapter flange, non-return valve and/or silencer can be attached to the gas exhaust point, depending on the application.

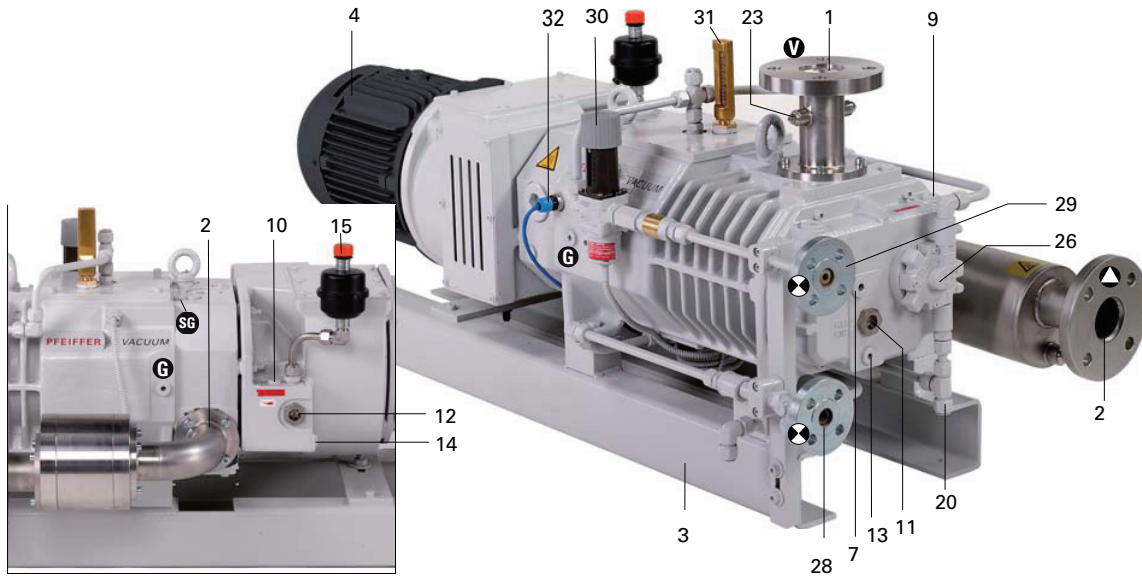

Fig. 3: Hepta 300, (similar image)

- | | | |
|---|--|----------------------------|
| 1 Vacuum flange (not included in the scope of delivery) | 9/10 Lubricant filler screw | 26 Circulation pump |
| 2 Exhaust (silencer) | 11/12 Sight glass | 28 Cooling water inlet |
| 3 Base frame | 13 Lubricant drain screw | 29 Cooling water outlet |
| 4 Motor | 14 Lubricant drain screw | 30 Thermostatic valve |
| 7 Cover screw for manual rotation of the rotors | 15 Cover of the gear chamber ventilation | 31 Thermometer |
| | 20 Cooling water drain screw | 32 Thermal circuit breaker |
| | 23 Flushing gas connection | |

Principle of operation

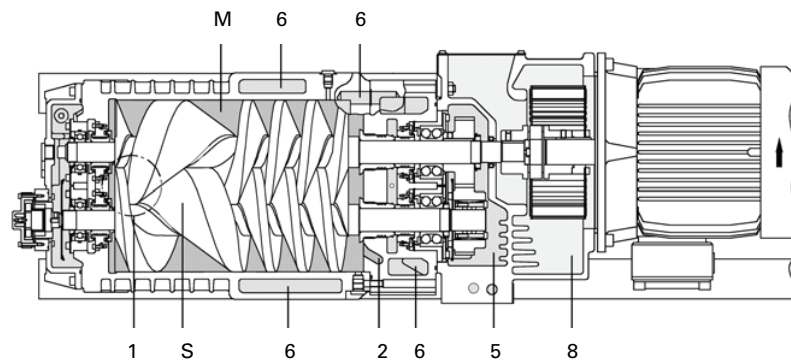

Fig. 4: Functioning principle

- | | | |
|---------------|-----------------|----------------|
| 1 Gas intake | 6 Cooling water | S Screw rotors |
| 2 Gas exhaust | 8 Cooling air | |
| 5 Gear oil | M Intake medium | |

Temperature monitoring

The vacuum pumps are equipped with a temperature switch in the pump housing. The switch temperatures depend on the pump size and the type of cooling system. Temperature monitoring prevents the vacuum pumps from overheating and possibly starting up.

Water cooling

To dissipate the heat arising from compression of the gases, the cooling chambers of the pump must be connected to an external coolant supply (e.g. water). The cooling water flows through the cooling chambers and absorbs the heat there. Connection of the flow-through cooling system is described under (see p. 13, chap. 5.3).

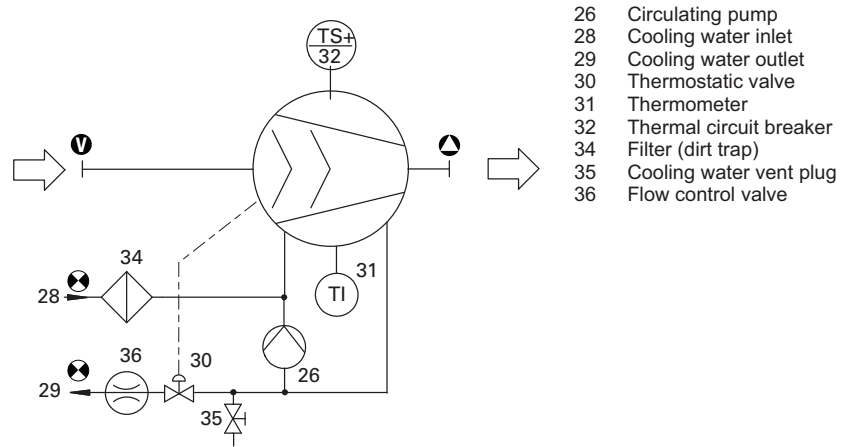

Fig. 5: Cooling water connection scheme

Silencer

The silencer reduces the pump noise and collects any condensates that may arise.

Non-return valve

The non-return valve prevents backflow of exhausted gases.

Connecting flushing air/flushing gas

According to the application and in order to guarantee efficient running of the pump, we recommend to flush the pump after each operation. The pump is flushed with air or flushing gas (usually nitrogen) which is sucked in through a separate connection into the inlet flange.

4.3 Range of application

The vacuum pumps are conceived for use in coarse and fine vacuum application. They can be used for pumping gases and gas mixtures. All corresponding product-specific safety requirements must be followed.

Make sure that no solids can enter the pump. We recommend installation of a suitable intake filter or protective strainer. The pump can transport a limited amount of surge fluid, which can enter the pump through process errors. If this happens, the pump must be run dry with flushing gas after the process end and the silencer completely emptied.

When installing the pump, observe the following conditions:

Installation location	Indoors, but with the pump protected against dust deposits Outdoors, but with the pump protected against direct sunshine, wind and precipitation.
Ambient pressure/operating pressure	Atmosphere ... ultimate pressure
Ambient temperature	0 ... 50°C
Temperature of the intake gases	dependent on the intake pressure and type of gas. The lower the intake pressure, the higher the intake temperature can be. The following can be assumed as typical values for air: – Intake pressure < 50 hPa --> intake temperature < 200°C – Intake pressure > 50 hPa --> intake temperature < 70°C
Counter pressure on the exhaust side	max. 20 kPa of overpressure
Cooling water conditions for flow-through cooling	– Temperature: 10 ... 25 °C – Network pressure: 300 ... 600 kPa (rel.) – Water hardness: < 5° dGH The cooling water must be neutral and clean. The water outlet must be free of pressure.
Supply voltage	according to the specifications on the motor rating plate
Relative air humidity	20 ... 95 % (depending on the motor version)
Installation altitude	max. 1000 m
Switching-on/off cycles	max. 6 per hour, 10 minutes standstill prior to switching on

5 Installation

5.1 Setting up the pump

When installing the pump, observe the following conditions:

- Always place the pump on a firm, even surface.
 - Check the load-bearing capacity of the floor at the installation location.
 - The vacuum flange serves as the reference surface.
 - Threaded holes in the anti-vibration buffers can be used for fastening.
- When installing the pump in a closed housing, ensure there is sufficient air circulation.
 - Both sight glasses must be visible and accessible for inspection and maintenance purposes.
 - Voltage and frequency information given on the motor rating plate must be visible.
- Fill up with lubricant before operating the first time (*see p. 12, chap.).*
 - Amount and type according to rating plate

5.2 Filling with lubricant

The type and amount of lubricant is visible on the pump's rating plate for each vacuum pump. Generally only the lubricant used during initial assembly can be used later on.

The delivery for the **standard pump** contains one filling of lubricant (separate package). For special applications (e.g. for pumping corrosive gases), other lubricants can be used also. These must be defined in accordance with Pfeiffer Vacuum specifications before initial assembly and ordered separately.

Permissible lubricants

- D1 (Standard operating fluid)
- Other operating fluids on request.



NOTICE

Use approved operating fluids only!

The use of operating fluids that have not been approved by Pfeiffer Vacuum shall result in a limited warranty. In such cases, it is not possible to guarantee that product-specific performance data will be achieved.

- Prior consultation is required before using other application-specific operating fluids.

Filling with lubricant

- Unscrew lubricant filler screws 9/10.
- Fill gear chamber and bearing chamber with lubricant up to the "max" sight glass marking.
 - Filling quantity: gear chamber = 1.1 l.
 - Filling quantity: bearing chamber (intake side) = 0.45 l.

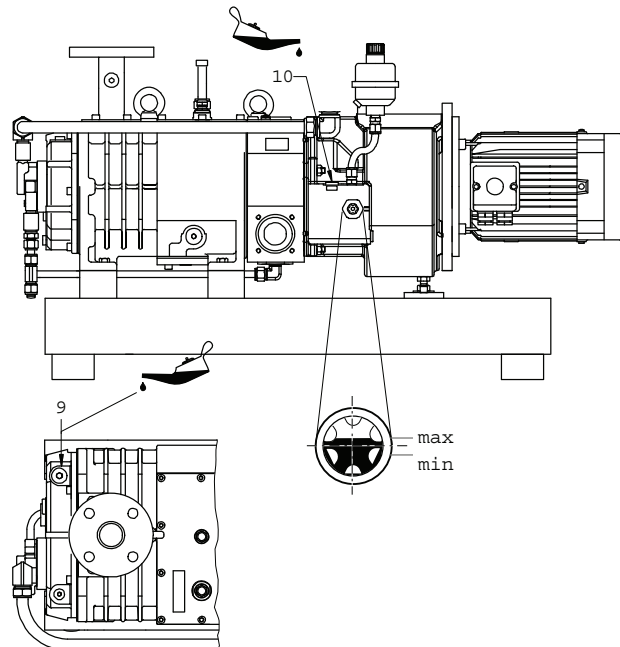

Fig. 6: Filling with lubricant



Request safety data sheets for operating fluids and lubricants

from Pfeiffer Vacuum or download them from the Internet.

→ Dispose of operating fluid according to the local regulations.

- Screw in lubricant filler screws 9/10.
- Close intake port valve (if present) or cover intake flange with a rubber mat.
- Start pump and run it for max. 5 minutes.
- Switch off pump and check fill level; add lubricant if necessary.
- Open intake port valve.

5.3 Connecting the cooling water



NOTICE

Pump damage caused by lack of cooling!

Inadequate cooling may cause pump damage.

→ Vent the cooling chambers and fill with coolant after repairs!

Before the vacuum pump is switched on, the flow-through cooling system must be connected to a coolant network and the following measures taken:

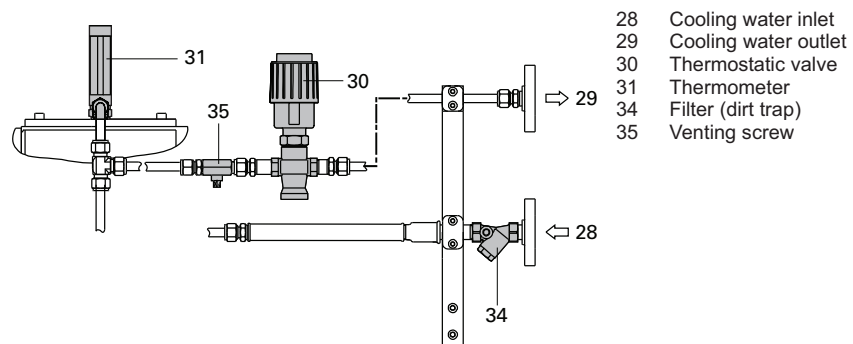

Fig. 7: Connecting the direct cooling system

- Connect cooling water lines; flange DN 15, PN 10 DIN 2566.
 - Hoses or pipes with a minimum diameter of 1/2" can be used as connection lines.
 - The cooling water outlet must be free of pressure.
- Open the cooling water feed.
- Open the venting screw 35 and fill the cooling system until cooling water comes out of the outlet.
- Close venting screw 35.
- Check the cooling water temperature with a thermometer 31.
- Correct setting of the thermostat valve 30, if necessary.

Setting thermostat valve

With the thermostat valve, the cooling water temperature can be adjusted to the process conditions: Position 1 (cold), position 5 (warm).



NOTICE

Damage to the screw rotor

Rapid change in the cooling water temperature can cause the screw rotors to start up.

- Change the thermostat valve only stepwise (1-2-3-4-5); the operating temperature of the pump must be able to stabilise itself between the individual steps.

5.4 Connecting the vacuum side



WARNING

Exposed, rotating rotors!

Fingers and hands can become crushed when the intake flange is open.

- Do not expose any body parts to the operating range of the rotors.
- Disconnect the motor from the power supply before performing work on the intake flange.



NOTICE

Danger of intake of solid particles!

Even in clean processes, fouling from the system must be anticipated during initial commissioning.

- Use a suitable start-up strainer at the intake connection (see accessories).
- Ensure that this strainer is only removed when the risk of solid particles entering the pump can be excluded.
- Note loss of pumping speed if necessary.

→ The connection between the pump and the vacuum chamber should be kept as short as possible and should have at least the nominal diameter of the pump flange. Use a greater nominal diameter on line lengths > 5 m.

→ Install shut-off valve in the intake line so that the process gas feed can be stopped.

→ Piping to the pump must be suspended or supported.

- Physical forces from the piping system must not be allowed to act on vacuum pumps.

→ Clear welded lines of any welding scales, loose parts etc. before installation.

5.5 Connecting the exhaust side



CAUTION

High pressure in the exhaust line!

Danger of damage to the seals and danger of the pump bursting.

- Install the line without shut-off valves on the exhaust side.
- If there is danger of a build-up of excess pressure (> 1500 hPa abs.) in the lines, observe all official accident prevention safety regulations.
- If the exhaust gases are being extracted, the exhaust pressure must be at least 250 hPa greater than the pressure at the intake side.

→ Choose the cross-section of the exhaust line to be at least the size of the nominal connection diameter of the vacuum pump's exhaust connection.

→ Piping to the pump must be suspended or supported.

- Physical forces from the piping system must not be allowed to act on vacuum pumps.

→ Lay piping from the pump sloping downward so that no condensate can flow back into the pump; otherwise fit a condensate separator.

- If an air trap is created in the system, then a device for draining condensation water must be provided at the lowest point.



WARNING

Emission of toxic substances from the exhaust!

Danger of poisoning from emitted gases or vapours, which can be detrimental to health and/or can pollute the environment, depending on the particular application.

- Comply with the applicable regulations when working with toxic substances.
- Only officially approved filter systems may be used to separate and remove these substances.

5.6 Connecting to the mains power supply

The pumps are supplied with three phase motors for different voltages and frequencies. The applicable motor type is shown on its rating plate.



DANGER

Voltage-bearing elements

Danger to life from electric shock.

- The electrical connection can be carried out only by trained and authorised electricians.
- Disconnect the power supply and secure it against being switched back on.
- Ensure the system is adequately earthed.



NOTICE

Excess voltage!

Danger of destroying the motor.

- Power connections must comply with local regulations. Voltage and frequency information given on the motor rating plate must correspond to the mains voltage and frequency values.
- To protect the motor and supply cable in case of malfunction, mains fuse protection must be implemented.



NOTICE

Danger of the pump being destroyed by impermissible rotation speed!

Exceeding or falling below the permissible frequency range can lead to destruction of the pump.

- When operating the motor with frequency converter the pump must be driven within the frequency range of 20 to max. 50/60 Hz; that is, do not run a 50 Hz pump with 60 Hz.

Checking the direction of rotation

The direction of rotation must be checked on pumps with three-phase motors!

Checking the direction of rotation using a phase sequence measuring instrument

The direction of rotation is generally checked with a phase sequence measuring instrument. A visual inspection should only be performed in exceptional cases after assessing the risk first.

In the motor terminal box, make the connections U1 - L1, V1 - L2 and W1 - L3 in a clockwise rotation as seen looking towards the drive shaft of the motor. Note that the correct direction rotation of the vacuum pump is anti-clockwise (clockwise rotation as seen looking towards the drive shaft of the pump).

→ If the direction of rotation is incorrect: Swap two phase contacts at the connecting cable.

Visual inspection of the direction of rotation

- Check the direction of rotation of the pump after switching on for the first time:
 - To do this, switch the pump briefly ON and OFF again (for a max. of 5 seconds).
- Compare the direction rotation of the motor and the motor ventilator with the directional arrow on the housing cover.
 - Looking from the motor side, the correct direction of rotation is in a clockwise direction.
- If the direction of rotation is incorrect: Swap two of the three phase contacts at the connecting cable.

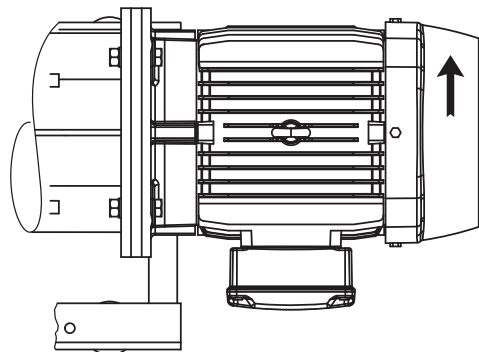

Fig. 8: Checking the direction of rotation (pump motor in top view)

Motor protection

Pump motors equipped with PTC temperature sensors (3PTC) in the stator windings can be connected to a PTC resistor tripping device for protection against overload. Other approved motor temperature monitoring can be used also by the operator.

Tripping devices store the shutdown event and need to be manually switched back on again via the integrated RESET button or via the external RESET S3. Mains-ON is detected as an automatic RESET.

→ Set up the connections so that the directional rotation indicated on the pump is maintained, regardless of the representations in the current flow diagram.

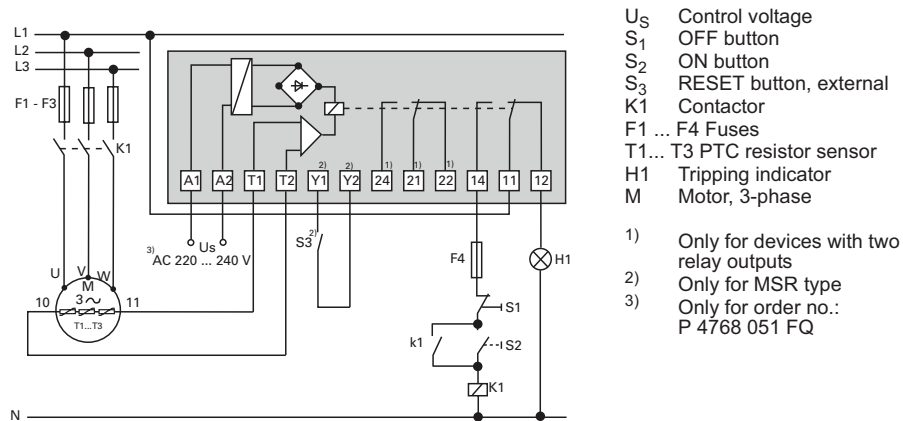

Fig. 9: Connection example for a three-phase AC motor with PTC resistor tripping device

The three phase current motor circuit

Delta Connection

The three coils are connected in series with the connection point connected to the mains. The voltage of each coil is the same as the mains voltage whereas the mains current is the cube root of the coil current. Delta connections are denoted by the symbol Δ . The voltage between the mains supply lines is called mains voltage. The mains current is the current which flows in the supply lines.

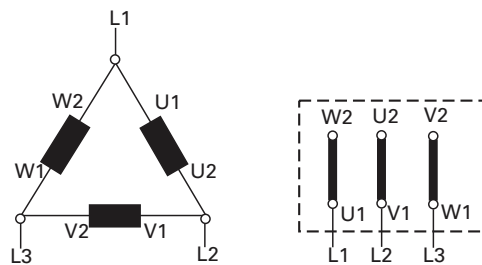

Fig. 10: Motor coil and connecting plate of Delta Connection (for low voltage)

Star Connection

The ends of the three coils are connected at the star center. The terminal voltage is the cube root of the coil voltage; the mains and the coil current are the same. Star connections are denoted by the symbol Y .

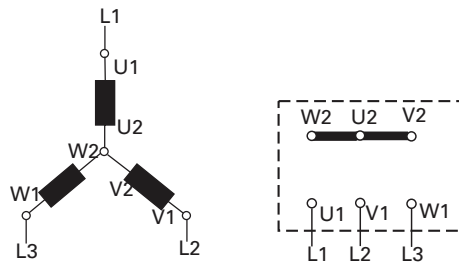

Fig. 11: Motor coil and connecting plate of Star Connection (for high voltage)

5.7 Connecting accessories

The following accessories are not included in the delivery, and can be ordered separately:

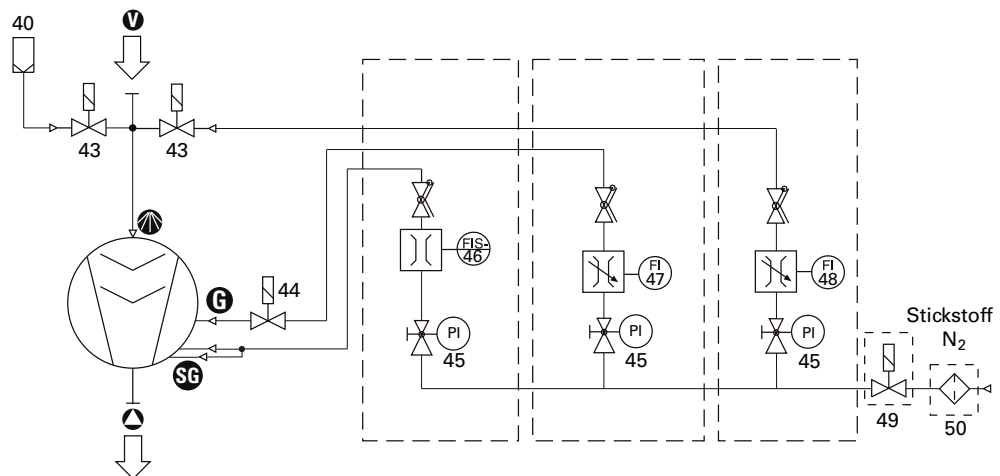
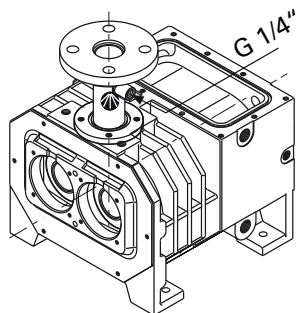

Fig. 12: Inertgas system

- | | | | | | |
|-----------|---------------------------------|----|--------------------------------------|----|------------------------|
| G | Gas ballast connection | 44 | Solenoid valve gas ballast | 48 | Flowmeter flushing gas |
| SG | Sealing gas connection | 45 | Pressure reducer | 49 | Solenoid valve |
| G | Flushing gas connection | 46 | Flowmeter sealing gas (with contact) | 50 | Filter |
| 40 | Filter flushing air | | | | |
| 43 | Solenoid valve flushing air/gas | 47 | Flowmeter gas ballast | | |

→ The nitrogen system should normally be connected using flexible hoses (1/4" diameter).

Connecting flushing air/flushing gas



If the medium being pumped is causing serious contamination or deposits in the suction chamber, the pump can be sprayed with flushing air/gas. Suction chamber flushing can proceed continuously or according to requirements during operations. A G1/4" thread is provided on the intake flange for admission of flushing air/gas.

Pump type	Flushing gas	
	Volume flow [NI/min]	Overpressure [kPa]
Hepta 100 ... 200 P	40	250
Hepta 300 P	50	250

Sealing gas function



NOTICE

Damage to the shaft seals!

The operation without sealing gas can damage the shaft seals.

- The sealing gas flow rate should not drop below the minimum flow value (1.5 NI/min). Use flow controller with contact, if necessary
- Keep a minimum rotation speed of 12 Hz.

Letting in sealing gas considerably increases the life of the shaft seal, bearing parts, and gear parts. Letting in sealing gas also prevents lubricant from the gear chamber penetrating the suction chamber. This is necessary if a high degree of purity is required of the vacuum being generated. The sealing gas connections are equipped with a G 1/4" thread.

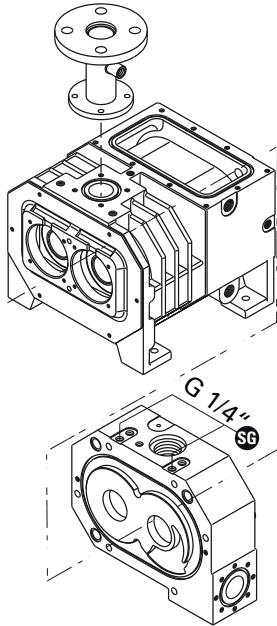

Pump type	Sealing gas	
	Volume flow [NI/min]	Overpressure [kPa]
Hepta 100 ... 200 P	2.5 ... 3	300
Hepta 300 P	2.5 ... 3	300

Gas ballast function

If condensable vapors or aggressive media are being pumped, the pump can be operated with gas ballast. This increases the gas temperature and dilutes the concentration of process gases. The gas ballast connections are equipped with a G 1/4" thread.

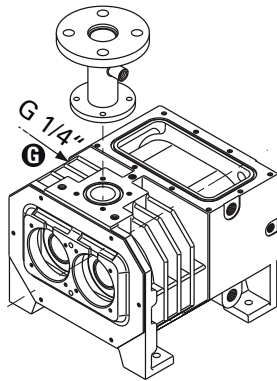

Pump type	Volume flow [NI/min]	Gas ballast
		Overpressure [kPa]
Hepta 100 ... 200 P	20	free air inlet < 450 hPa intake pressure
Hepta 300 P	20	

6 Operation

6.1 Before switching on

- Check lubricant levels at both sight glasses and at the oiler as well.
- Check process-specific and pump-specific media supplies.
- Operate shut-off units in the exhaust line in such a way that they open before or at the same time as starting the pump.
- Protect the pump sufficiently from taking in contaminants by means of suitable precautions (e.g. protective strainer); if necessary, check lubricant regularly or replace at shorter intervals.

6.2 Switching on the pump

The pump can be switched on in any pressure range between atmospheric and ultimate pressure.

- Switch on vacuum pump via mains power supply;
 - The pump achieves its operating temperature after approx. 30 minutes and thus the maximum ultimate pressure.
- Open cooling water supply and check the flow; adjust if necessary.
- When sealing gas is used: Open the sealing gas supply and check the flow.
- When gas ballast is used: Open the gas supply and check the flow.
- Open shut-off valve in the intake line and switch the pump over to the process.
- Check the pump operation visually and acoustically. If malfunctions occur (noise, overheating, etc.), switch off the pump immediately.



CAUTION

Hot surface!

Danger of burns if hot parts are touched. Depending on the operating and ambient conditions, the surface temperature of the pump may rise above 80 °C.

- In this case, use suitable finger guards.



WARNING

Increased noise emission!

Increased noise emission can occur within a limited area surrounding the vacuum pump.

- Provide noise protection or
- wear hearing protection.

Temperature monitoring

A temperature switch built into the pump cylinder is used to monitor the pump temperature.

The electrical connection must be made in such a way that an alarm is triggered when the trigger point (125°C) is exceeded. The pump must be switched off no more than 30 seconds afterward.

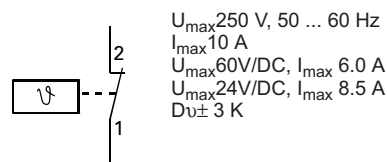

Fig. 13: Connecting the temperature switch

6.3 Switching off

In the case of clean processes that convey pure gases, the pump can be switched off in every pressure range and directly after the process end. When the evacuated medium in the suction chamber causes strong contamination or deposits, the vacuum pump should be flushed with air or nitrogen after the process end.



CAUTION
<p>Danger of damage to the inside of the pump! Danger of contamination of the pump interior when pumping out reactive gases. → After pumping, flush the pump interior with nitrogen.</p>

- Close shut-off valve in the intake line and separate the pump from the process.
- Turn off the vacuum pump, vent to atmospheric pressure and allow to cool, if necessary.
- When inert gas is used: Stop inert gas supply.
- Stop cooling water supply.

Flush pump with flushing gas

- Close shut-off valve in the intake line and separate the pump from the process.
- Open flushing gas feed at the intake flange.
- Pump is operated for an additional 20 to 40 minutes while flushing gas is suctioned in.
- Turn off the vacuum pump, vent to atmospheric pressure and allow to cool, if necessary.
- Stop flushing gas feed.
- Stop cooling water supply.

Flush pump with liquid

In the case of special applications in which process materials can stick inside the pump, the pump interior can be flushed with liquid.

If water is used as the flushing liquid, it must be demineralised (<5° dGH):

German GH	French GH	English GH	American GH
1° dGH	1.78°	1.25 e	17.9 mg/kg CaCO ₃

Fig. 14: Hardness (GH) conversion table

- Close shut-off valve in the intake line and separate the pump from the process.
- Open flushing liquid feed at the intake flange.
- Operate the pump (10 ... 15 minutes) with $n < 30$ Hz during the flushing process.
- After the flushing process, continue to operate the pump for another 20 minutes with closed intake line to remove liquid remnants completely.
- Turn off the vacuum pump, vent to atmospheric pressure and allow to cool, if necessary.
- Stop flushing liquid feed.
- Stop cooling water supply.

7 Maintenance

7.1 Precautions



WARNING

Pump parts may be contaminated from pumped media!

Danger of poisoning due to contact with harmful substances.

- Decontaminate the pump before carrying out any maintenance work.
 - In the event of contamination, take suitable safety precautions to prevent your health from being harmed by any dangerous substances.
-
- Turn off the vacuum pump, vent to atmospheric pressure and allow to cool, if necessary.
 - Disconnect the drive motor from the mains and secure it so that it cannot be switched on.
 - Remove the vacuum pump from the system, if necessary.
 - Allow the lubricant to drain off.
 - Stop cooling water feed and remove cooling water intake and output lines.
 - Blow compressed air through the cooling water system and completely empty cooling water channels to avoid rust and frost damage.
 - Only dismantle the pump as far as necessary in order to repair defects.
 - Dispose of used operating fluid in compliance with local regulations.
 - When using synthetic operating fluids or working with toxic substances or substances contaminated with corrosive gases, the relevant instructions governing their use must be observed.
 - Use only alcohol or similar agents for cleaning pump parts.

Checklist for inspection, maintenance and overhaul

Certain repair and overhaul work should only be performed by Pfeiffer Vacuum Service (PV). Pfeiffer Vacuum will be released from all warranty and liability claims if the required intervals for inspection, maintenance, or overhaul are exceeded or inspection, maintenance, repair or overhaul procedures are not performed properly. This also applies if replacement parts other than Pfeiffer Vacuum OEM replacement parts are used.

Maintenance intervals depend very greatly on individual operating conditions. The following values should be considered typical values that may be shortened or lengthened. For operation under difficult conditions, such as high dust in the environment or in the gases to be pumped, a considerable shortening of the maintenance interval can occur.

Checks	Daily	Weekly	Monthly	Yearly
Check fill level of gear and bearing chamber oil	X			
Check condensates in the exhaust silencer; drain, if necessary	X			
Check the cooling water flow; check system for leak-tightness	X			
Examine pump for oil leaks		X		
Examine pump for coolant leaks		X		
Examine pump for cooling water leaks		X		
Check suction chamber for dust deposits; clean, if necessary			X	
Visually check the entire pump			X	
Check electrical connections			X	
Check intake strainer; clean if necessary				X
Check functioning of the measuring and safety equipment				X

Service work	1000 h	5000 h	10000 h	16000 h
Clean ventilator cowl of the drive motor	X			
Clean exhaust silencers	X			
Check non-return valve for dirt; clean, if necessary	X			
Check air filter at the flushing device for dirt; clean or replace, if necessary	X			
Change gear and bearing oil		X		
Check cooling water connection lines for dirt; clean, if necessary		X		
Check intake and exhaust lines; clean or replace, if necessary.			X	
Check inert gas lines for dirt; clean or replace, if necessary			X	
Check oil-lubricated floating ring seal; replace if necessary			(PV)	
Check seals; replace if necessary			(PV)	

Pump undergoes general overhaul (PV) But not later than every 4 years

Depending on the process, the required intervals for the lubricant and the intervals for inspection and service may be less than the typical values specified in the table. If necessary consult with Pfeiffer Vacuum.

7.2 Changing the lubricant



WARNING

Hot operating fluid!

Danger of burns when draining due to contact with skin.

- Wear suitable protective clothing.
- Use a suitable collecting vessel.

Changing the lubricant

The intervals for replacing lubricant in the gear and bearing chambers are heavily dependent upon the operating conditions.

- Change the lubricant at least once every year.
- Turn off the vacuum pump, vent to atmospheric pressure and allow to cool, if necessary.
- Unscrew lubricant filler screws 9/10.
- Unscrew the lubricant drain screws 13/14 and drain the lubricant; pay attention to the O-rings!

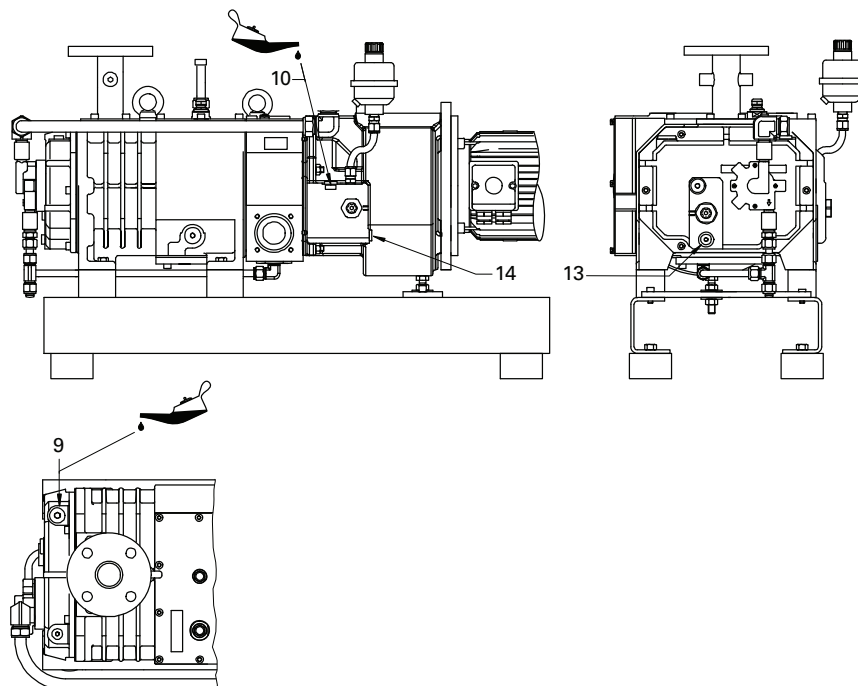

Fig. 15: Changing the lubricant



WARNING

Operating fluid may contain toxic substances from the pumped media!

Danger of poisoning from the emission of harmful substances from the operating fluid.

- Wear suitable protective clothing and respirators.
- Dispose of operating fluid according to the local regulations

- Screw in lubricant drain screws 13/14; pay attention to the O-rings.
- Fill with new lubricant and check fill level.
- Screw in lubricant filler screws 9/10.



Request safety data sheets for operating fluids and lubricants

from Pfeiffer Vacuum or download them from the Internet.

- Dispose of operating fluid according to the local regulations.

7.3 Drain condensate in the silencer



DANGER

Release of toxic materials

Danger to health through contact with toxic substances during operation, service and maintenance work.

→ The operator must provide suitable protective clothing for all work on open chambers and vacuum components.

→ Drain condensate regularly via the drain hole K of the silencer and collect in a vessel;
– define adequate, process-specific drain intervals.

→ Dispose of condensate according to the respectively valid legal requirements.

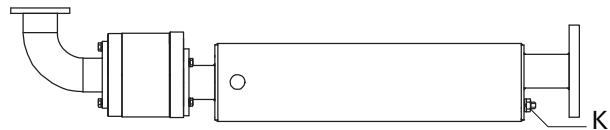

Clean silencer

→ Clean silencer approx. every 1000 h, depending on the process.

→ Remove silencer from the pump.

→ Clean with suitable cleaning agent.

→ Dry silencer sufficiently and install it again.

Clean non-return valve

→ Clean non-return valve approx. every 1000 h, depending on the process.

→ Check function of the non-return valve; if necessary, clean it with suitable cleaning agent and make it mobile.

→ Dry non-return valve sufficiently and install it again.

7.4 Check the oil lubricated mechanical seals

The floating ring seals consume a small amount of oil, max. 1.5 cm³/month. If consumption is high, the limit of wear has been exceeded or there is damage to the surface. It should be replaced not later than this.

8 Decommissioning

8.1 Shutting down for longer periods

Perform the following procedure:

- Turn off the vacuum pump, vent to atmospheric pressure and allow to cool, if necessary.
- Stop cooling water feed and remove cooling water intake and output lines.
- Blow compressed air through the cooling water system and completely empty cooling water channels to avoid rust and frost damage.
- Store the pump only indoors, preferably at temperatures between -10 °C and $+40\text{ °C}$.
 - In rooms with moist or aggressive atmospheres, the pump must be airproof shrink-wrapped in a plastic bag together with a bag of desiccant.
 - After storage periods longer than two years, it is recommended to carry out maintenance and change the lubricant before using the pump.
- Do not store pump in the vicinity of machines, lanes, etc., because strong vibrations can damage the rotor bearings.

8.2 Re-starting

Visually inspect the inner of the pump before taking it into operation. If there is evidence of rust on the parts of the pump which form the housing, then do not take it into operation and contact Pfeiffer Vacuum Service.

Depending on how long the pump is taken out of operation, it may be necessary to replace the elastomer parts. In accordance with DIN 7716 and the manufacturer's specifications we recommend replacing the installed elastomer parts after 2 years.



NOTICE

Re-starting

The serviceability of the lubricant without operation is a maximum of 2 years. Before re-starting after a shut-down of **2 years or longer**, carry out the following work.

- Replace the lubricant.
 - Replace bearings.
 - Follow the maintenance instructions and inform Pfeiffer Vacuum.
- If drying pearls were inserted then they should be removed now. Improper handling can cause failure of the pump.

Loosen stuck screw rotors

After a standstill of several days or after sticky substances have been suctioned away, it may happen that the screw rotors stick to each other.

In this case, do the following:

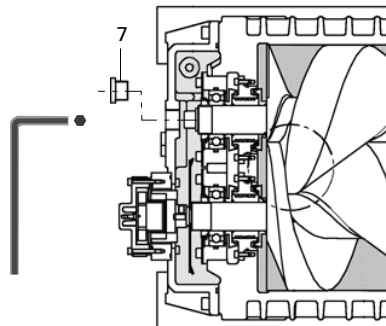

- Loosen blanking plug 7 and screw it out.
- With an Allen key (possibly with extension), turn the screw rotors clockwise by hand and make them mobile.

→ Screw the cover screw 7 back on; switch on the pump and flush it (see p. 22, chap. 6.3).

8.3 Disposal

Products or parts thereof (mechanical and electrical components, operating fluids, etc.) may cause environmental burden.

→ Safely dispose of the materials according to the locally applicable regulations.

9 Malfunctions

Please note the following instructions should the pump malfunction:



CAUTION
<p>Hot surface! Danger of burns if hot parts are touched. The surface temperature of the pump may rise above 105 °C in case of malfunction.</p> <p>→ Carry out work on the pump only after it has cooled to a safe temperature.</p>

9.1 Rectifying malfunctions



NOTICE
<p>Service work should be carried out by qualified personal only! Pfeiffer Vacuum is not liable for any damage to the pump resulting from work carried out improperly.</p> <p>→ Take advantage of our service training programs; additional information at www.pfeiffer-vacuum.com.</p> <p>→ Please state all the information on the pump rating plate when ordering spare parts.</p>

Problem	Possible causes	Remedy
Pump will not start up	Motor voltage is incorrect	Apply correct motor voltage.
	Motor protection switch is too small or set to a trigger value that is too small.	Correct trigger value; set to a value of approx. 5% above the rated motor current.
	A fuse is defective	Check the fuses.
	Voltage drop in the connection cable is too high	Dimension the connection cable adequately.
	Pump or drive motor is blocked	Ensure that the drive motor has been separated from the power supply: – Remove ventilator cover. – Try to rotate the motor by hand If this is not possible: – Remove motor and check motor and pump separately If the pump is blocked, inform PV Service
Vacuum pump is blocked	Drive motor defective	Replace drive motor.
	Foreign bodies entered the pump	If the pump is blocked, inform PV Service. Install filter or strainer in intake line
	Pump system etched inside or condensate has collected	Inform PV Service. Check process and pump medium; plan for condensate siphon.
	Incorrect direction of rotation	Inform PV Service. Check direction of rotation; if necessary, exchange two phases of the electrical connection.
	Circulation pump is blocked	Remove and clean circulation pump

Problem	Possible causes	Remedy
Pump not achieving the ultimate	Intake line plugged	Clean line
	Leak in the system	Check line.
	Pump interior plugged with process residue	Remove pump.
Long pumping-out times	Long intake line or cross section of the exhaust line is too small.	Shorten intake lines and increase cross section of the exhaust line.
Increased current input	Counter-pressure too high	Check exhaust line, clean if necessary
	Pump plugged with process residue	Remove pump.
	Cooling liquid or cooling water lacking	Check cooling liquid or cooling water.
	Lubricant contaminated	Change lubricant.
Unusual noises during operation	Loose cable connection; motor runs only with 2 phases	Check lines.
	Direction of rotation false	Check direction of rotation; if necessary, exchange two phases of the electrical connection.
	Longer pump standstill time	Allow the pump to warm up with closed intake flange.
	Bearing damage	Inform PV Service.
	Coupling defective	Remove motor and coupling; replace coupling, if necessary.
	Motor runs - pump doesn't: only valid for pumps with magnetic coupling system (AM/ADM series)	Magnetic coupling system defective or magnetic field "broken away", contact Pfeiffer Vacuum Service if necessary. Attention! Magnetic field: If the magnetic field has "broken away", the orientation of the magnets with respect to each other can only be re-established at standstill. If the pump is left to operate with a "broken away" magnetic field, demagnetisation will take place and the coupling is destroyed.
Overpressure at the exhaust	Exhaust line plugged	Check exhaust line, clean if necessary.
	Pressure switch at the exhaust (option) defective	Check pressure switch at the exhaust (option).
Pump pressure too high	Ambient temperature too high	Maintain permissible ambient temperature.
	Gas temperature too high	Maintain permissible intake temperature.
	When coolant is used: Check fill level	Fill with coolant, if necessary.
	Cooling water feed lacking or cooling water pressure too low	Check feed and flow; increase cooling water pressure, if necessary.
	Counter-pressure too high	Check exhaust line, clean if necessary.
	Increased gas temperature due to special process gases	After sufficient cooling, switch pump back on.
	Intake or exhaust line partially clogged	Check line cross-sections; clean if necessary
	Pump interior plugged with process residue	Remove pump.
	Lubricant level too low	Refill with lubricant; check the shaft sealings.
Low lubricant level	Loss of oil to the outside or inside	Check tightness of the oil chambers (cover, seals). Check the shaft sealings.

10 Service

Pfeiffer Vacuum offers first-class service!

- Maintenance/repairs on site by Pfeiffer Vacuum field service
- Maintenance/repairs in a nearby service center or service point
- Fast replacement with exchange products in mint condition
- Advice on the most cost-efficient and quickest solution

Detailed information and addresses at: www.pfeiffer-vacuum.com (Service).

Maintenance and repairs in Pfeiffer Vacuum ServiceCenter

The following steps are necessary to ensure a fast, smooth servicing process:

- Download the forms "Service Request" and "Declaration on Contamination".¹⁾
- Fill out the "Service Request" form and send it by fax or e-mail to your Pfeiffer Vacuum service address.
- Include the confirmation on the service request from Pfeiffer Vacuum with your shipment.
- Fill in the contamination declaration and enclose it in the shipment (required!).
- Dismantle all accessories.
- Drain operating fluid/lubricant.
- Drain cooling medium, if used.
- Send the pump or unit in its original packaging if possible.

Sending of contaminated pumps or devices

No units will be accepted if they are contaminated with micro-biological, explosive or radioactive substances. "Hazardous substances" are substances and compounds in accordance with the hazardous goods directive (current version). If pumps are contaminated or the declaration on contamination is missing, Pfeiffer Vacuum performs decontamination at the shipper's expense.

- Neutralise the pump by flushing it with nitrogen or dry air.
- Close all openings airtight.
- Seal the pump or unit in suitable protective film.
- Return the pump/unit only in a suitable and sturdy transport container and send it in while following applicable transport conditions.

Service orders

All service orders are carried out exclusively according to our repair conditions for vacuum units and components.

¹⁾ Forms under www.pfeiffer-vacuum.com

11 Spare parts

Please also specify model number of the the rating plate when ordering accessories or spare parts.

12 Accessories

Designation	Hepta 100	Hepta 200	Hepta 300
SAS 63, DN 63 ISO-K, polyester filter	PK Z60 511	PK Z60 511	PK Z60 511
Barretter actuation unit 3TF	P 4768 051 FQ	P 4768 051 FQ	P 4768 051 FQ
D1, oil, 1 l	PK 005 875 -T	PK 005 875 -T	PK 005 875 -T
D1, oil, 5 l	PK 005 876 -T	PK 005 876 -T	PK 005 876 -T
D1, oil, 20 l	PK 005 877 -T	PK 005 877 -T	PK 005 877 -T

Further detailed accessories are contained in the Pfeiffer Vacuum printed or Online Catalogue.

13 Technical data and dimensions

13.1 General

Conversion table: pressure units

	mbar	bar	Pa	hPa	kPa	Torr mm Hg
mbar	1	$1 \cdot 10^{-3}$	100	1	0.1	0.75
bar	$1 \cdot 10^3$	1	$1 \cdot 10^5$	1000	100	750
Pa	0.01	$1 \cdot 10^{-5}$	1	0.01	$1 \cdot 10^{-3}$	$7.5 \cdot 10^{-3}$
hPa	1	$1 \cdot 10^{-3}$	100	1	0.1	0.75
kPa	10	0.01	1000	10	1	7.5
Torr mm Hg	1.332	$1.332 \cdot 10^{-3}$	133.32	1.3332	0.1332	1

1 Pa = 1 N/m²

Conversion table: gas throughput units

	mbar l/s	Pa m ³ /s	sccm	Torr l/s	atm cm ³ /s
mbar l/s	1	0.1	59.2	0.75	0.987
Pa m ³ /s	10	1	592	7.5	9.87
sccm	$1.69 \cdot 10^{-2}$	$1.69 \cdot 10^{-2}$	1	$1.27 \cdot 10^{-2}$	$1.67 \cdot 10^{-2}$
Torr l/s	1.33	1.33	78.9	1	1.32
atm cm ³ /s	1.01	0.101	59.8	0.76	1

13.2 Technical data

Hepta 100/200/300 -/P

Parameter	Hepta 100 P	Hepta 200	Hepta 300 P
Flange (in)	DN 63 ISO-K	DN 63 ISO-K	DN 63 ISO-K
Flange (out)	DN 40 PN 16	DN 50 PN 16	DN 50 PN 16
Nominal pumping speed at 50 Hz	110 m ³ /h	220 m ³ /h	320 m ³ /h
Ultimate pressure	≤ 0.05 hPa	≤ 0.05 hPa	≤ 0.05 hPa
Nominal rotation speed at 50 Hz	3000 rpm	3000 rpm	3000 rpm
Sound pressure level	70 dB (A)	71 dB (A)	72 dB (A)
Ambient temperature	0-50 °C	0-50 °C	0-50 °C
Protection category	IP 55	IP 55	IP 55
Motor rating 50 Hz	3.5 kW	6 kW	7.5 kW
Mains requirement: voltage 50 Hz	190-208/380-415 V	190-208/380-415 V	190-208/220-240/380-415 V
Operating fluid	D1	D1	D1
Operating fluid filling	1.6 l	1.6 l	1.6 l
Weight	275 kg	326 kg	330 kg
Cooling water pressure	300-600 kPa	300-600 kPa	300-600 kPa
Cooling water temperature	10-25 °C	10-25 °C	10-25 °C
Cooling water consumption	2-6 l/min	2-6 l/min	2-6 l/min

13.3 Dimensions

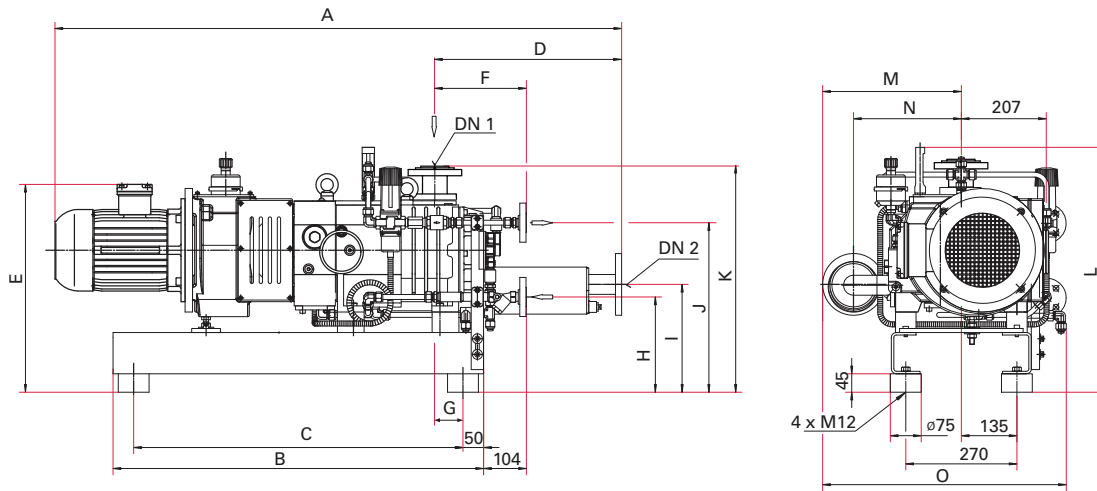

Fig. 16: Hepta 100

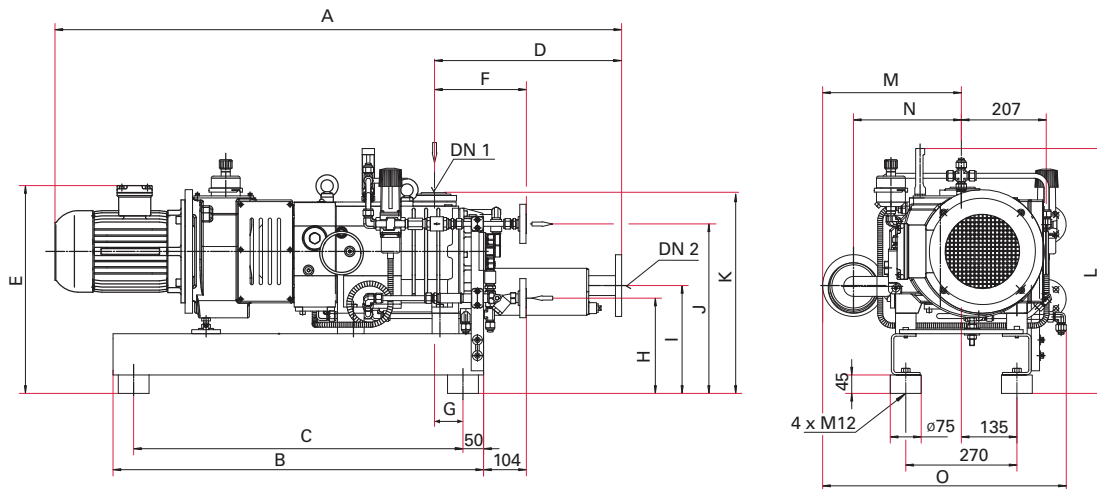

Fig. 17: Hepta 200/300

Dimensions	Hepta 100	Hepta 200	Hepta 300
A	1395 mm	1664 mm	1660 mm
B	900 mm	1160 mm	1230 mm
C	800 mm	1060 mm	1130 mm
D	454 mm	602 mm	533 mm
E	505 mm	552 mm	552 mm
F	222 mm	237 mm	236 mm
G	68 mm	83 mm	81 mm
H	232 mm	232 mm	231 mm
I	262 mm	278 mm	262 mm
J	412 mm	412 mm	411 mm
K	533 mm	491 mm	495 mm
L	597 mm	609 mm	609 mm
M	337 mm	365 mm	364 mm
N	262 mm	282 mm	282 mm
O	586 mm	619 mm	620 mm
DN1	DN 63 ISO-K	DN 63 ISO-K	DN 63 ISO-K
DN2	DN 40 PN 16	DN 50 PN 16	DN 50 PN 16

Dimensions with
IE2 motors

Dimensions	Hepta 100 P	Hepta 200	Hepta 300 P
A	1395 mm	1664 mm	1660 mm
B	900 mm	1160 mm	1230 mm
C	800 mm	1060 mm	1130 mm
D	454 mm	602 mm	533 mm
E	-	-	-
F	222 mm	237 mm	236 mm
G	68 mm	83 mm	81 mm
H	232 mm	232 mm	231 mm
I	262 mm	278 mm	262 mm
J	412 mm	412 mm	411 mm
K	533 mm	491 mm	495 mm
L	597 mm	609 mm	609 mm
M	337 mm	365 mm	364 mm
N	262 mm	282 mm	282 mm
O	586 mm	619 mm	620 mm
DN1	DN 63 ISO-K	DN 63 ISO-K	DN 63 ISO-K
DN2	DN 40 PN 16	DN 50 PN 16	DN 50 PN 16



Declaration of conformity

according to the EC directive:

- **Machinery 2006/42/EC (Annex II, no. 1 A)**

We hereby declare that the product cited below satisfies all relevant provisions of EC directive "Machinery" **2006/42/EC**.

In addition, the product cited below satisfies all relevant provisions of EC directive "Electromagnetic Compatibility" **2004/108/EC**.

The agent responsible for compiling the technical documentation is Mr. Sebastian Oberbeck, Pfeiffer Vacuum GmbH, Berliner Straße 43, 35614 Asslar.

HeptaDry™
Hepta 100/200/300 -/P

Guidelines, harmonised standards and national standards and specifications which have been applied:

DIN EN ISO 12100 : 2011-03	DIN EN ISO 2151 : 2009	DIN EN 61000-6-2 : 2006
DIN EN 1012-2 : 1996	DIN EN ISO 13857 : 2008	DIN EN 61000-6-3 : 2007
DIN EN ISO 14121-1 : 2007	DIN EN 61000-6-1 : 2007	DIN EN 61000-6-4 : 2007

Signatures:

Pfeiffer Vacuum GmbH
Berliner Straße 43
35614 Asslar
Germany

(M. Bender)
Managing Director

(Dr. M. Wiemer)
Managing Director

CE/2011

**Vacuum solutions
from a single source**

Pfeiffer Vacuum stands for innovative and custom vacuum solutions worldwide, technological perfection, competent advice and reliable service.

**Complete range
of products**

From a single component to complex systems: We are the only supplier of vacuum technology that provides a complete product portfolio.

**Competence in
theory and practice**

Benefit from our know-how and our portfolio of training opportunities! We can support you with your plant layout and provide first-class on-site-service worldwide.

**Are you looking for a
perfect vacuum solution?
Please contact us**

Pfeiffer Vacuum GmbH
Headquarters • Germany
T +49 6441 802-0
info@pfeiffer-vacuum.de