



ASM 380

Mobile high performance helium leak detector

Operating instructions

ASM 380 Helium Leak Detector

Dear Customer,

You have just bought an adixen detector.

We would like to thank you and we are proud to count you among our customers.

This product is a result of the experience acquired since many years in vacuum and leak detection technology.

The applications of helium leak testing are extremely diversified ranging from hi-tech installation maintenance to high-speed testing of industrial products.

Each product of the adixen detector range is designed to meet the specific needs of each application:

- high sensitivity
- pumping capacity
- pumping type
- mobility

while remaining simple to use, whether you are an expert or novice in leak detection.

ASM 380 Helium Leak Detector

This product complies with the requirements of European Directives, listed in the Declaration of Conformity contained in G 100 of this Manual.

Copyright/Intellectual property:

The use of adixen products are subject to copyright and intellectual property rights in force in any jurisdiction. All rights reserved, including copying this document in whole or any part without prior written authorization from adixen Vacuum Products.

Specifications and information are subject to change without notice by adixen Vacuum Products.

Translated from original version

ASM 380 - Operating instructions

Preliminary remarks Throughout this operating manual, you could find this type of message **""Setting" menus arborescence**  **C 600**": it refers to a specific chapter of the operating manual. Please read it for further information.

Chapter A

INTRODUCTION

- A 100** - Presentation
- A 200** - About leak detection
- A 300** - Options
- A 400** - Accessories
- A 500** - Technical characteristics
- A 600** - Dimensions

Chapter B

INSTALLATION

- B 100** - Safety instructions
- B 110** - Unpacking / Packing - Storage - Handling
- B 111** - Supplies delivered with the leak detector
- B 112** - Labels on/inside the leak detector
- B 200** - Neutral gas purge and inlet vent connection
- B 220** - Customizable rear panel
- B 240** - Accessories installation
- B 300** - Controlling detector
- B 301** - RS 232
- B 302** - 15 pin Interface
- B 303** - 37 pin Input/Output interface
- B 304** - USB
- B 305** - Wi-Fi
- B 306** - Ethernet
- B 308** - Bluetooth
- B 400** - Starting up / Switching off of the leak detector

Chapter C

OPERATION

- C 100** - Getting started with the leak detector
- C 110** - Perform a test
- C 200** - Control panel
- C 300** - Graphic display
- C 400** - Settings
- C 401** - Set points Menu
- C 402** - Test Menu
- C 403** - Spectro Menu
- C 404** - Maintenance Menu
- C 405** - Configuration Menu
- C 406** - Advanced Menu
- C 500** - Factory configuration of the leak detector parameters
- C 600** - «Setting» menus arborescence
- C 700** - Remote control (accessory)
- C 800** - Wireless remote control (accessory)
- C 900** - Long distance sniffer probe and Helium spray gun (accessories)

Translated from original version

ASM 380 - Operating instructions

Chapter D

MAINTENANCE

- D 100** - Indicator lights and default display
- D 200** - General troubleshooting guide
- D 200 / D 300** - General troubleshooting guide / Symptoms description
- D 300** - Symptoms description

Chapter E

MAINTENANCE SHEETS

- E 100** - Maintenance operation instructions
- E 110** - Access to internal components
- E 120** - Table of preventive maintenance intervals
- E 141** - Leak detector tightness checking
- E 142** - Leak detector depollution
- E 231** - P0411 Supervisor board
- E 410** - Autocalibration of the leak detector
- E 411** - Calibration of a leak detector connected to a pumping group
- E 412** - Calibrated leaks
- E 413** - Maintenance of the internal calibrated leak
- E 430** - Analyzer cell maintenance
- E 437** - Analyzer cell complete dismantling
- E 500** - PI3C gauge maintenance and replacement
- E 530** - Valves installation and maintenance
- E 532** - Depression valves installation and maintenance
- E 550** - Replacement of a fan
- E 555** - Replacement of the purge filter
- E 600** - Remote control
- E 610** - Long distance sniffer probe and Helium spray gun
- E 630** - Control panel maintenance
- E 640** - Replacement of the vacuum vessel
- E 650** - Replacement of the wheels
- E 703** - Replacement of the ACP 40 primary pump silencer or hose
- E 730** - Starting of the molecular and turbomolecular pumps

Chapter F

COMPONENTS

- F 000** - Spare parts - Instructions of use
- F 001** - adixen Customer Service Offer
- F 100** - Tools
- F 200** - Monitoring and display
- F 300** - Power and electrical supply
- F 400** - Automatic control system and electronic circuits
- F 500** - Measurement
- F 600** - Pumping
- F 700** - Valves
- F 800** - Pipes - Connections - Seals
- F 900** - Cover
- F 1000** - Options and accessories
- F 1100** - Pictures of components

Translated from original version

ASM 380 - Operating instructions

Chapter G

APPENDIX

- G 100** - Declaration of conformity
- G 200** - Wiring diagram (Index -)
- G 400** - Long distance sniffer probe user manual
- G 500** - Helium spray gun manual
- G 600** - Safety questionnaire
- G 700** - Units
- G 800** - Tools

CAUTION

Indicates a potentially hazardous situation which, if not avoided, could result in property damage.

CAUTION

Indicates a potentially hazardous situation which, if not avoided, could result in moderate or minor injury. It may also be used to alert against unsafe practices.

WARNING

Indicates a potentially hazardous situation which, if not avoided, could result in death or severe injury.

DANGER

Indicates an imminently hazardous situation that, if not avoided, will result in death or severe injury (extreme situations).



Introduction

ASM 380 Operating instructions Detailed contents

Preliminary remarks Throughout this operating manual, you could find this type of message **""Setting" menus arborescence**  **C 600"**: it refers to a specific chapter of the operating manual. Please read it for further information.

| | |
|--------------|---------------------|
| A 100 | <i>Presentation</i> |
|--------------|---------------------|

| | |
|--------------|-----------------------------|
| A 200 | <i>About leak detection</i> |
|--------------|-----------------------------|

- Overview
- Vacuum circuit of a leak detector
- Test method
- Analyzer cell operating principle
- About helium and hydrogenated nitrogen

| | |
|--------------|----------------|
| A 300 | <i>Options</i> |
|--------------|----------------|

- Bluetooth option
- Inputs/Outputs option
- Profibus option
- Industrial control panel
- Electronic unit / vacuum modules cables
- Sniffing kit

| | |
|--------------|--------------------|
| A 400 | <i>Accessories</i> |
|--------------|--------------------|

- He calibrated leaks
- Calibration accessory in sniffing
- Remote control
- Sniffer probe
- Liquid sniffer probe
- Helium spray gun
- Locking clamp DN 40 KF
- Bombing chambers
- Inlet filters
- Transport case
- Transport cart
- Bottle holder
- Bluetooth
- Input/Output board
- Profibus board
- Industrial control panel
- Sniffing kit
- 2005 SI Pump
- Interface extension kit
- Power supply cords
- Measurement gauge

| | |
|--------------|----------------------------------|
| A 500 | <i>Technical characteristics</i> |
|--------------|----------------------------------|

| | |
|--------------|-------------------|
| A 600 | <i>Dimensions</i> |
|--------------|-------------------|

Presentation



The **ASM 380** is the moving adixen leak detector at dry pumping, high performance, for the maintenance of high technology environment.

- Compact and greater mobility to come closer to tested system.
- Combination of high performance pumpings allowing to reduce the test time on large volumes.
- Reduced maintenance cost.
- Color interface operator, swivel, 100 % customizable to meet your needs.
- Greater leak signal legibility thanks to a high performance signal treatment.
- Fully designed to simplify the operator work.

With the **ASM 380**, the helium leak detection has been never so easy.

About leak detection

Overview Leak detection is used to detect micro-openings, porosities, permeation through materials etc. The means of detection is a tracer gas: Helium. This gas is so light that it can penetrate microscopic cracks very fast.

The analyzer cell measures helium partial pressure created by helium molecules that come from the leaking parts. These molecules are pumped in by the vacuum pumps of the helium leak detector and end up inside the analyzer cell. This partial helium pressure is converted into a flow rate. The analyzer cell is tuned to detect three gas species, hydrogen (M2), helium isotope (M3) and helium (M4). For more information on the operating principle, please go to the end of this chapter.

A leak detector, according the model, can detect a leak as large as 10^{-2} mbar l/s down to a leak as small as 3×10^{-11} mbar l/s.

A leak of 10^{-2} mbar l/s is equivalent to a bubble of 1 cc escaping a part every 100 seconds.

A leak of 3×10^{-11} mbar l/s corresponds to a bubble of 1 cc escaping a part every 1,050 years.

As for reference, please see below for more leak rate correlations. For the same size crack, a part will leak out helium at different rates based on the internal helium pressure. The greater the internal helium pressure, the higher the leak rate.

Leak testing large leaks versus leak testing tiny leaks will require different settings, for more information, please go to chapter C.

| Leak Rate | $3 \cdot 10^{-11}$ mbar l/s | $1 \cdot 10^{-10}$ mbar l/s | $1 \cdot 10^{-9}$ mbar l/s | $1 \cdot 10^{-8}$ mbar l/s | $1 \cdot 10^{-7}$ mbar l/s | $1 \cdot 10^{-6}$ mbar l/s | $1 \cdot 10^{-5}$ mbar l/s | $1 \cdot 10^{-4}$ mbar l/s | $1 \cdot 10^{-3}$ mbar l/s |
|-----------------------------|-----------------------------|-----------------------------|----------------------------|----------------------------|----------------------------|----------------------------|----------------------------|----------------------------|----------------------------|
| 1 cc Bubble over time frame | ≈ 1050 years | ≈ 317 years | ≈ 31,7 years | ≈ 3,17 years | ≈ 116 days | ≈ 11.6 days | ≈ 1,2 days | ≈ 2,7 hours | ≈ 17 minutes |

About leak detection

Vacuum circuit of a leak detector

The general vacuum diagram of the leak detector is shown below. A dynamic version of the vacuum diagram is available on the leak detector display panel. Green valves indicate opened valves. Red valves indicate closed valves.

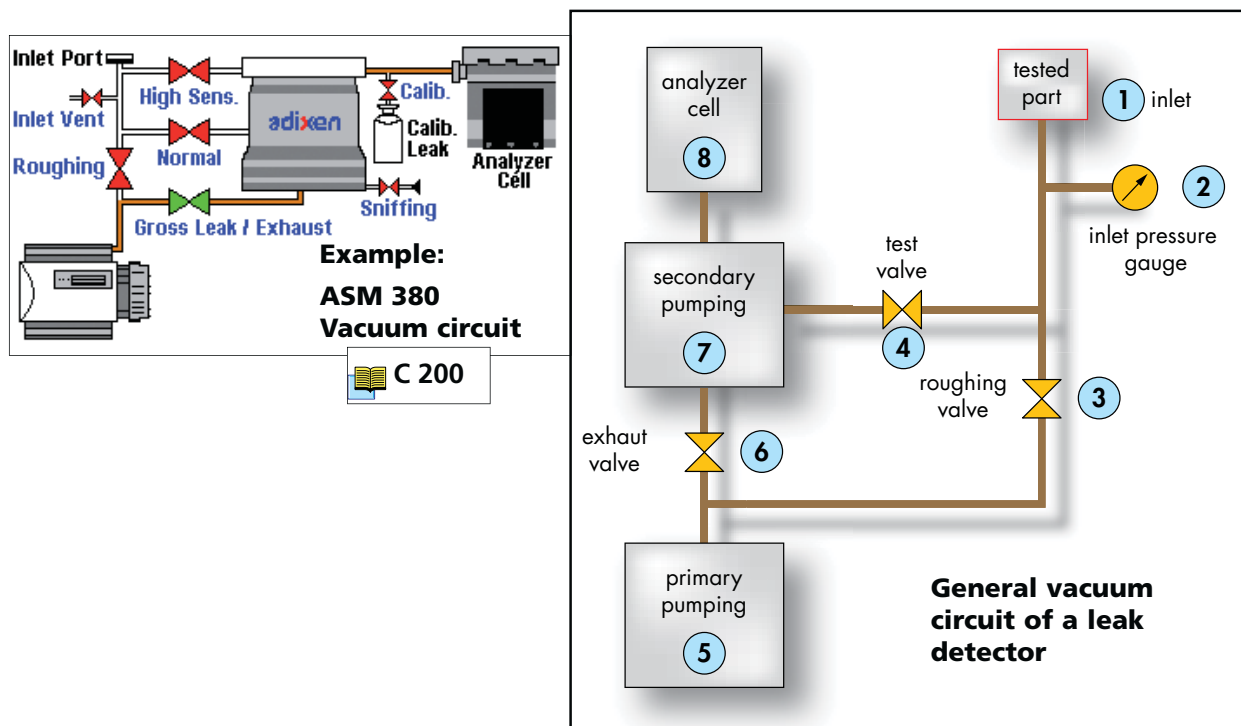

- Test Procedure:
- Connect the part to be tested at the inlet of the leak detector (1), then press the [START/Stand by] key.

When the unit is not in test mode (stand-by or roughing mode), the helium displayed corresponds to the internal helium background of the unit.

- Roughing Mode: Valve (3) opens and the primary pump evacuates the inlet of the unit as well as the part connected to it.
- When the inlet pressure (2) reaches the test cross over, the roughing valve (3) closes, the exhaust valve (6) opens, the test valve (4) opens. The high vacuum is then connected to the inlet of the leak detector taking care of the gas load. The analyzer cell (8) will measure any helium present. The value of the leak will be measured and displayed on the control panel.

About leak detection

Test method

Choice Several test methods are possible.
The testing method is selected according to the test part and the measurement range required:

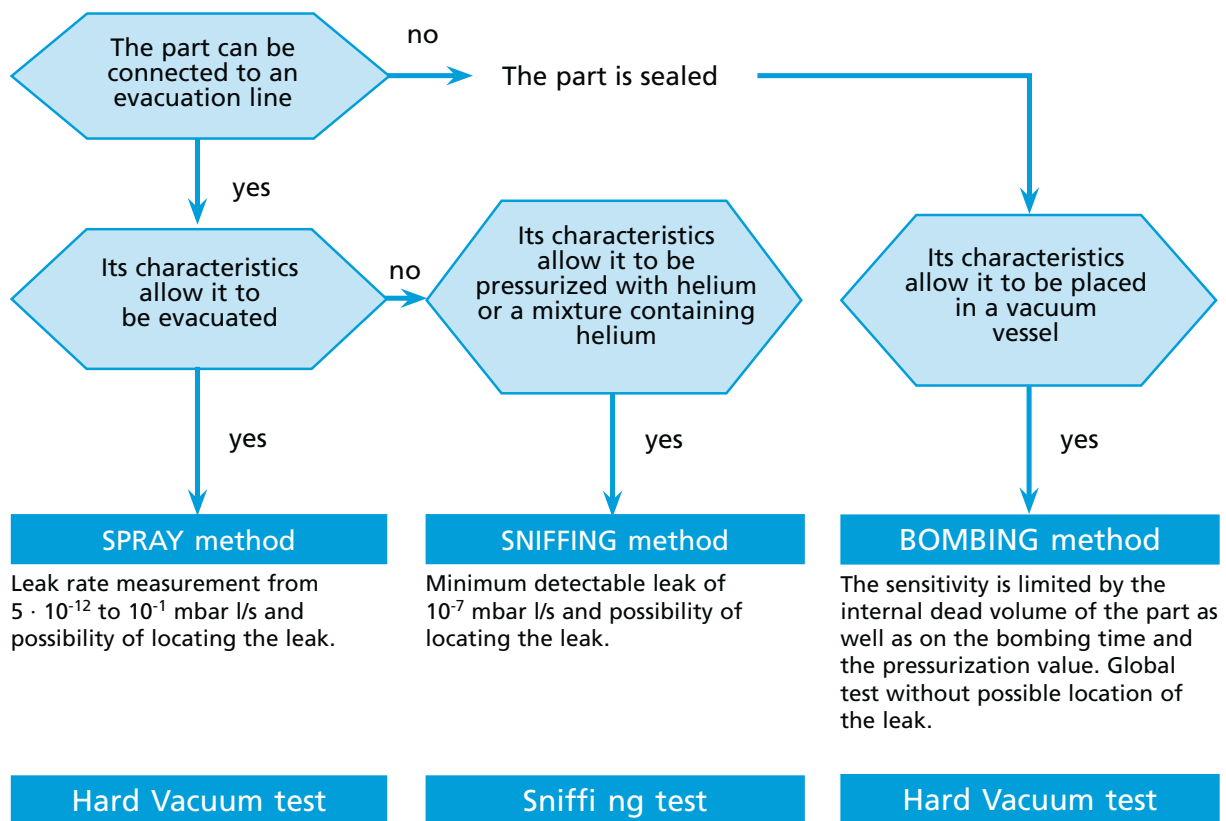

About leak detection

Spray method This involves removing air from the part tested, connecting it to the analyzer cell and then spraying helium over the outer surface.

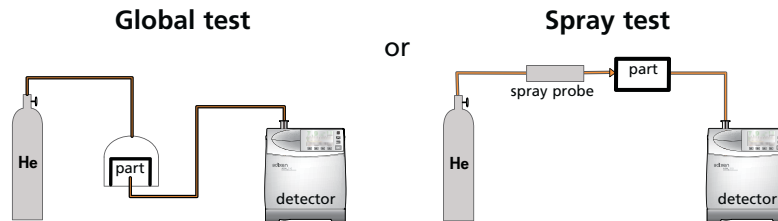

The part is placed under a cover, into which helium is injected.

Potential leaking areas are sprayed with helium.

The leak cannot be located.

The leak can be located.

The detector measures the flow of helium penetrating the part.

Connection rules: refer to  **B 300**

Response time

When spraying starts, the leak signal is not displayed instantaneously on the analyzer cell:

there is a response time which depends on the volume V being tested and the helium pumping speed S of the system at the opening of the part, according to the following relation:

$$T = V/S \quad (\mathbf{T \text{ in second, } V \text{ in litre, } S \text{ in l/s})$$

T is the time required for the signal to reach 63 % of the final value.

About leak detection

Sniffing method

The test part is pressurized with helium. The detector, via a sniffer probe samples the helium escaping from the part.

Global test is generally kept for gross leaks ($> 10^{-3}$ mbar l/s). In 90 % of uses, the sniffing method is used in local.

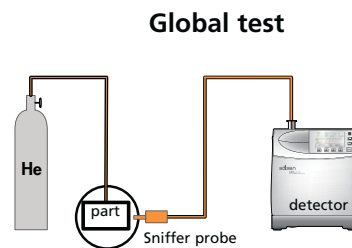

The part is placed under a cover containing a sniffer probe.

The leak cannot be located.

The helium from the leak accumulates over time inside the cover. The detector measures the concentration of helium.

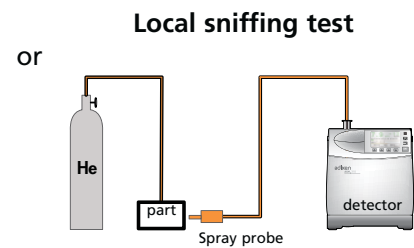

The sniffer probe is moved over areas likely to contain leaks.

The leak can be located.

The signal supplied by the analyzer is not an exact measurement of the leak. The sniffer probe only samples part of the helium escaping from the part. The sample depends on the distance separating the leak from the tip of the probe.

About leak detection

Bombing method This method is used for sealed objects that cannot be connected directly to the detector (semiconductors, waterproof watches, etc.).

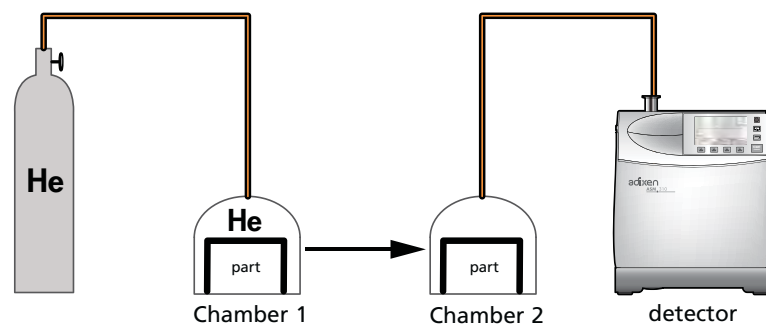

The part is placed in a chamber containing pressurized helium.

The helium penetrates the part if it has a leak.

The part is then removed from the chamber and placed in another vacuum chamber which is connected to the detector. The helium escapes from the part through the leak and produces a signal.

This signal is not a direct measurement of the leak as the helium pressure inside the part is difficult to determine. Several parts play an important part such as: the pressurization time, the helium bombing pressure, the internal volume, the aeration time, the size of the leak.

Please consult us for details about this method.

About leak detection

Analyzer cell operating principle

Description The analyzer cell works on the principle of mass spectrometry and is set by default to the mass of helium ($m/e = 4$). Other gases can be used (helium 3 or hydrogen).

m/e = atomic mass of the particle/number of electrons lost on ionization.

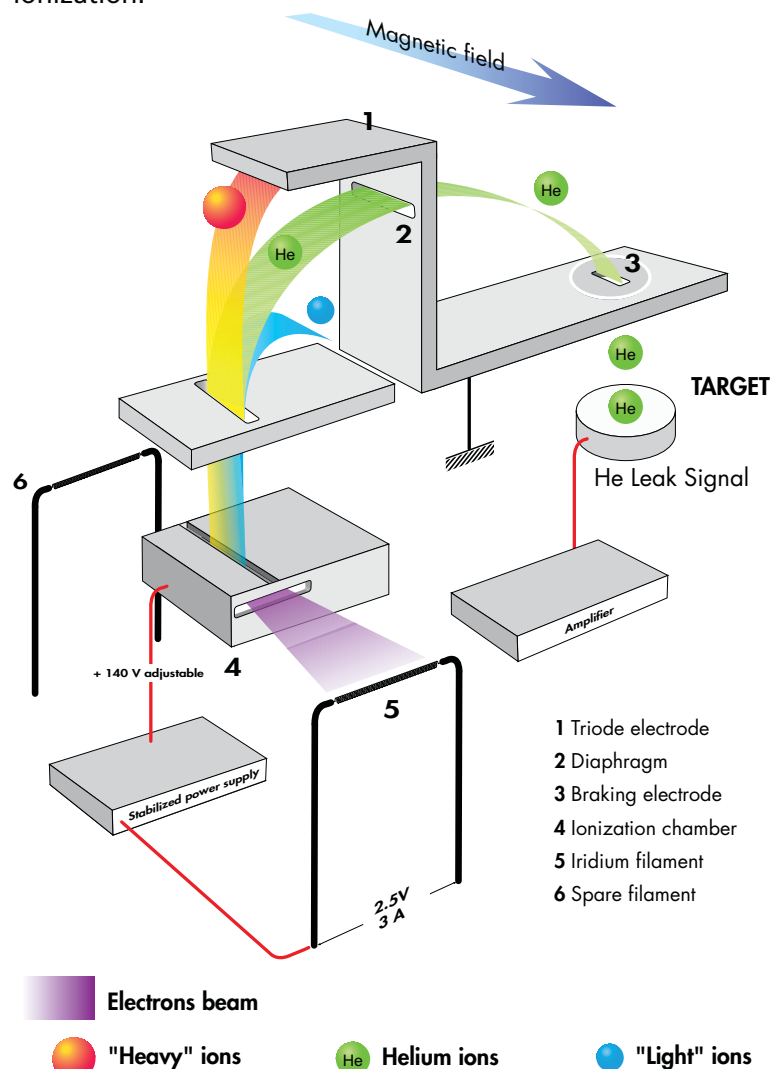

The principle of magnetic deflection spectrometry is as follows. The molecules of the gas being analyzed pass into an ionization chamber 4 where they are bombarded by an electron beam generated by a heated iridium filament 5. A large number of the molecules are transformed into ions.

About leak detection

The iridium filament allows a good performance at high pressures and a small overheating.

These ionized particles are accelerated by an electrical field.

They arrive in a zone subjected to a magnetic field which has the property of deflecting the trajectories of the ions along different curves according to the masses of those ions (to be more preceded, according to their m/e ratios). Thus the ions beam, which contained ions with different masses, is divided into several beams, each containing only ions with the same m/e ratio. For example, the helium ions ($m/e = 4$) are separated from the lighter (H^{2+} or H^{1+} , smaller beams) or heavier ions (N^{2+} or O^{2+} , bigger beam).

The triode electrode **1** collects the ions which the mass is higher than the tracer gas mass. The electronic current measured in this way allows to calculate the total pressure in the analyzer cell.

Because there is a constant magnetic field (permanent magnet), the accelerator electrical field is adjusted so that the tracer gas ions follow a pre-determined trajectory (passing through diaphragm **2**) and arrive on the target at the input to a direct current amplifier.

In order to separate the helium ions from "noise" caused by other ions, an electrode located in front of the target eliminates them. This electrode **3** is called the "braking electrode".

The current of ions of the tracer gas is proportional to the partial pressure this one in the installation and by measuring it we can find the flow rate of the leak that has been detected.

It is essential that the total pressure in the analyzer cell is less than 10^{-3} mbar so that the trajectories of the electrons and the ions are not disturbed by residual molecules.

There is a spare iridium filament **6** in the analyzer cell.

About leak detection

About helium and hydrogenated nitrogen

Helium

Helium is the second most common element in the universe, representing about 23 % of the total matter. 76 % is Hydrogen. All other elements represent an insignificantly small fraction of the total.

Helium is a 100 % green gas and has absolutely no environmental impact on the atmosphere.

Helium was discovered by spectroscopy in a solar eclipse on August 18, 1868. The discovery in the sun's chromosphere gave the new element its name: "helios" in Greek means "sun". While Helium is very common in the universe most of it is in the stars: on earth it is actually not abundant. Since it is so light all the Helium present during the formation of earth escaped to space.

Helium is created deep in the earth from the radioactive decay of uranium and thorium which also gives the earth its internal heat. On earth Helium was discovered in 1881 by spectroscopy of Mount Vesuvio in Italy – the volcanic gases emanated by the mountain showed the same lines in the spectrum as already known from the sun.

Helium concentration in the atmosphere is 5 times bigger than the one of Krypton and 60 times higher than Xenon. The heavier noble gases are isolated from air rectification. In contrary, Helium is "mined" from natural gas and oil wells and stored. The annual world wide production is ca. 3×10^7 m³ or 4,500 tons.

Helium is constantly seeping up from the ground all around us, but it is so light that almost all of it escapes into space fairly rapidly. On the other hand there is a constant flow of Helium from space and the sun to earth. This gives a dynamic equilibrium and is the reason for the world wide constant concentration of 5 ppm Helium in air. Helium is a very light colorless element and it is one of the six noble gases which means it doesn't react with anything for all practical intents and purposes. It's the most difficult gas to liquefy.

It's used as an inert shield gas to protect things from oxidation – and of course as leak detection tracer gas.

Helium and leak detection: which purity?

Helium is commercialized in many different purity levels, the highest level of purity is requested from some laboratories for fundamental researches or very accurate analyses.

The use of the Helium as a tracer gas into a mass spectrometer doesn't require such attention. A purity in the range of 97 % to 99 % is enough.

There is absolutely no risk of accuracy lost or contamination for the analyzer cell by using standard purity level of Helium gas.

About leak detection

Hydrogenated nitrogen If Hydrogen (H_2) and Oxygen (O_2) are mixed and heated, they react and create water vapor (H_2O). During this process more heat is generated which may (if the concentration is high enough) ignite the surrounding gas. If this process propagates, the gas explodes.

At low concentration of Hydrogen (< 4 % in air) the generated heat is not enough to ignite the surrounding gas.

At concentrations in the range 4 to 12 % the combustion may spread only if actions are taken to prevent the generated heat from dissipating. It is a common misconception that hydrogen will explode as soon as the concentration exceeds 4 %. It may explode only if conditions are favorable for spontaneous propagation of combustion.

 **DANGER**

Never use pure hydrogen or a mixture with a hydrogen concentration higher than 10 % to realize a "hydrogen" test as tracer gas.

If you use the recommended tracer gas of 5 % H_2 / 95 % N_2 and mix it with air there will either be too little hydrogen or too little oxygen to constitute a combustible gas mixture. Hence this gas mixture is classified as non flammable. The actual limit is 5.7 %.

The mixture 10 % H_2 / 90 % N_2 is commonly used in the industry because it is flammable only under certain conditions. This mixture is however classified according to ISO 10156 as Flammable Gas and should only be used after due safety considerations and approvals.

Options

| Which options for which model? | | ASM 310 | ASM 380 | ASI 30 |
|--|---|---------|---------|--------|
| Bluetooth (*) | 1 | | • | • |
| 37 pin Input/Output board (*) | 2 | | | |
| 37 pin Input/Output board with Bluetooth (*) | | | • | • |
| 37 pin Input/Output board with Wi-Fi (*) | | | | |
| 37 pin Input/Output board with Ethernet (*) | | | | |
| Profibus board (*) | 3 | | | • |
| Profibus board with Bluetooth (*) | | | | |
| Industrial control panel (*) | 4 | | | • |
| Electronic unit/vacuum module cables (*) | 5 | | | • |
| Sniffing kit (*) | 6 | | | • |

(*) Also available in accessories

Options

Bluetooth option Bluetooth allows users to communicate without cable, through PDA or PC, with their leak detectors.

1

PDA and PC must be supplied by the customer.

Maximum distance to communicate without cable with Bluetooth technology put in adixen leak detectors is:

- 10 m with PDA,
- 30 m with PC.

Check compatibility between « Bluetooth » and the other interfaces in option/accessory: refer to  B 300.

Details: Refer to  B 308.

Inputs/Outputs option 4 options :

2

- 37 pin I/O board
- 37 pin I/O board and Bluetooth
- 37 pin I/O board and Wi-Fi
- 37 pin I/O board and Ethernet

37 pin I/O board It offers:

- a RS 232 interface,
- a USB interface,
- a 37 pin Input/Output interface.

37 pin input/output board offers a complete RS 232 protocol:

- 4 command modes : basic, advanced, spreadsheet, data export,
- possibility to control the detector (start/stop, zero, auto-calibration, ...),
- possibility to set adjustments,
- possibility to get maintenance information for preventive maintenance.

It offers also, instead of standard 15 pin interface, many adjustable inputs/outputs.

Options

| | | 15 pin interface | 37 pin I/O board |
|---------|---|------------------|------------------|
| Inputs | Quantity | 1 | 6 |
| | Number of possible values for each input | 1 | 13 |
| Outputs | Quantity | 5 | 12 |
| | Number of possible values for each output | 1 | 25 |

Check compatibility between « Input/Output board » option and the other interfaces in option/accessory: refer to  B 300.

37 pin I/O board with Bluetooth

This option offers in the same time:

- Bluetooth board : refer to option 1
- 37 pin inputs/outputs board: refer to option 2.

37 pin I/O board with Wi-Fi

It offers:

- a RS232 interface,
- a USB interface,
- a Wi-Fi interface,
- a 37 pin input/output interface.



It offers Wi-Fi functionalities as a supplement to 37 pin input/output board functionalities.

Check compatibility between « Input/Output board with Wi-Fi » option and the other interfaces in option/accessory: refer to  B 300.

37 pin I/O board with Ethernet

It offers:

- a RS232 interface,
- a USB interface,
- an Ethernet interface,
- a 37 pin input/output interface.



It offers Ethernet functionalities as a supplement to 37 pin input/output board functionalities.

Options

Check compatibility between « Input/Output board with Ethernet » option and the other interfaces in option/accessory: refer to  B 300.

Profibus option

3

2 options:

- Profibus board
- Profibus board with Bluetooth

Profibus board



It offers:

- a sub D 9 pin interface,
- a 15 pin input/output interface.

Check compatibility between « Profibus » option and the other interfaces in option/accessory: refer to  B 300.

Profibus board with Bluetooth

This option offers in the same time:

- Bluetooth board : refer to option  1,
- Profibus board: refer to option  3.

Industrial control panel

4

The detector is available with or without industrial control panel with ½ 19" rack format.

4 cables lengths linking electronic unit and control panel are proposed: 3.5 m, 5 m, 10 m or 20 m.

Electronic unit / vacuum modules cables

5

3 cables lengths linking electronic unit and control panel are proposed: 1.8 m, 5 m or 10 m.

Sniffing kit

6

This option allows working in sniffing mode.

This option is not installed in the delivered leak detector: at the customer's charge to install it ( B 240).

The option use requires a primary pumping associated to the leak detector: at the customer's charge.

Sniffing probe required in sniffing mode is not delivered in the kit: at the customer's charge. To choice your sniffer probe, refer to chapter  A 400.

Accessories

Accessories Common to all leak detectors

| | |
|-----------------------------------|----|
| Calibrated leaks | C1 |
| Calibration accessory in sniffing | C2 |
| Remote control | C3 |
| Sniffer probe | C4 |
| Liquid sniffer probe | C5 |
| Helium spray gun | C6 |
| Locking clamp | C7 |
| Bombing chambers | C8 |
| Inlet filters | C9 |

Specific accessories to one or several leak detectors

| | | ASM 310 | ASM 380 | ASI 30 |
|---|-----|---------|---------|--------|
| Transport case | S1 | • | | |
| Transport cart | S2 | • | | |
| Bottle support | S3 | | • | |
| Bluetooth (*) | S4 | | • | • |
| 37 pin Input/Output board (*) | S5 | | • | • |
| 37 pin Input/Output board with Wi-Fi (*) | | | | |
| 37 pin Input/Output board with Ethernet (*) | | | | |
| Profibus board (*) | S6 | | | • |
| Industrial control panel (*) | S7 | | | • |
| Sniffing kit (*) | S8 | | | • |
| 2005 IS primary pump | S9 | | | • |
| Interface extension kit | S10 | | | • |
| Power supply cords | S11 | • | | • |
| Measurement gauge | S12 | | | • |

(*) also available in option

You can find via our Web Site free softwares designed to help you in your applications. Refer to  **G 800**.

Accessories

C1 He calibrated leaks



(from 10^{-9} mbar l/s to 10^{-4} mbar l/s)

- Supplied with certificate of calibration.
- ± 10 % accuracy.
- Possibility to deliver a standard value (included in a predetermined range, see table below) or a specific value according to the customer requirement.

| Decade | Range code | Standard value provided | Reservoir |
|--------------------|------------|--|-------------------------|
| 10^{-9} mbar l/s | 9 | between 1 and $3 \cdot 10^{-9}$ mbar l/s | Aluminium |
| 10^{-8} mbar l/s | 8 | between 1 and $3 \cdot 10^{-8}$ mbar l/s | Aluminium |
| 10^{-7} mbar l/s | 7 | between 1 and $3 \cdot 10^{-7}$ mbar l/s | Aluminium |
| | 3 | between 3 and $6 \cdot 10^{-7}$ mbar l/s | 250 cc stainless steel |
| 10^{-6} mbar l/s | 6 | between 1 and $3 \cdot 10^{-6}$ mbar l/s | 250 cc stainless steel |
| | 5 | between 5 and $8 \cdot 10^{-6}$ mbar l/s | 250 cc stainless steel |
| 10^{-5} mbar l/s | 4 | between 1 and $3 \cdot 10^{-5}$ mbar l/s | 1000 cc stainless steel |
| | 2 | between 5 and $8 \cdot 10^{-5}$ mbar l/s | 1000 cc stainless steel |
| 10^{-4} mbar l/s | 1 | between 1 and $3 \cdot 10^{-4}$ mbar l/s | 1000 cc stainless steel |

Accessories

F 4

| | Isolation valve | |
|------|-----------------|------|
| | without | with |
| code | 0 | V |

Manual isolation valve. The isolation valve is mandatory for values greater than $8 \cdot 10^{-6}$ mbar l/s

| | Gaz |
|------|--------|
| | Helium |
| code | 4 |

| | Decades | | | | | |
|------|-----------|-----------|-----------|-----------|-----------|-----------|
| | 10^{-9} | 10^{-8} | 10^{-7} | 10^{-6} | 10^{-5} | 10^{-4} |
| code | 9 | 8 | 7 3 | 6 5 | 4 2 | 1 |

| | Flange | | | |
|------|--------|-------|-------|------------------|
| | DN 16 | DN 25 | DN 40 | DN 50 |
| code | 0 | 1 | 2 | 3 ⁽¹⁾ |

(1) DN 50 not available for decades 10^{-5} and 10^{-4} mbar l/s

| | Specific value | |
|------|----------------|----|
| | yes | no |
| code | 1 | 0 |

- Temperature coefficient 3 % per degree Celsius for any value $< 8 \cdot 10^{-6}$ mbar l/s (permeation type), 0.2 % per °C for greater value (capillary type).
- Loss 2 % per year for any value $< 8 \cdot 10^{-6}$ mbar l/s.
- When a specific value is requested, due to the technology used,
- The manufacturer can only guarantee an effective nominal value within ± 20 % of the requested nominal value.

Ex: requested value = $1.8 \cdot 10^{-6}$ mbar l/s

- guaranteed delivered value between 1.44 et $2.16 \cdot 10^{-6}$ mbar l/s

- code in DN25 with a valve **FV4611**, and indicates

"requested value = $1.8 \cdot 10^{-6}$ mbar l/s".

C2 Calibration accessory in sniffing

Used to connect the calibrated leak and the sniffer probe for a calibration.

| Model | Part No |
|-------|---------|
| DN 16 | 110715 |
| DN 25 | 110716 |



Accessories

C3 Remote control

The remote control is equipped with magnets allowing the operator to place it on a magnetized surface. The operator can read the helium signal and has access to control keys such as cycle command autocalibration and auto-zero.



English serigraphy

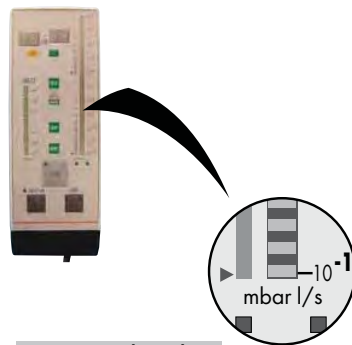

mbar l/s
or Torr l/s
or Pa m³/s

Japanese serigraphy

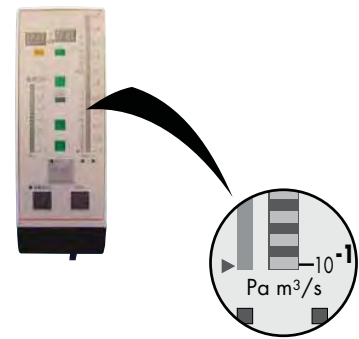

Pa m³/s
only

Remote control with 5 m/16.4 feet cable length:

| Model | Part No |
|--|---------|
| Unit: mbar l/s - Front face in English | 106688 |
| Unit: Torr l/s - Front face in English | 108881 |
| Unit: Pa m ³ /s - Front face in English | 108880 |
| Unit: Pa m ³ /s - Front face in English | 106690 |



Cable only

Cable for remote control (remote control not provided):

| Model | Part No |
|--------------------------------------|---------|
| Cable of 10 m/32.8 feet/394 inches | 101881 |
| Cable of 15 m/49.2 feet/590 inches | 101882 |
| Cable of 20 m/65.5 feet/787 inches | 802494 |
| Cable of 25 m/82 feet/984 inches | 802339 |
| Cable of 30 m/98.4 feet/1181 inches | 802767 |
| Cable of 35 m/114.8 feet/1378 inches | 802768 |
| Cable of 40 m/131.2 feet/1575 inches | 802769 |
| Cable of 45 m/147.6 feet/1772 inches | 802770 |
| Cable of 50 m/164 feet/1968 inches | 802771 |

Accessories

C4 Sniffer probe Sniffer probe with rigid nozzle Sniffer probe with flexible nozzle



| Sniffer probe part number | 5 m tubing | | | | 10 m tubing | | | |
|---------------------------|--------------|----------|------------------|----------|--------------|----------|------------------|----------|
| | Rigid nozzle | | Flexible nozzle* | | Rigid nozzle | | Flexible nozzle* | |
| | 9 cm | 30 cm | 15 cm | 45 cm | 9 cm | 30 cm | 15 cm | 45 cm |
| | SNC1E1T1 | SNC1E2T1 | SNC1E3T1 | SNC1E4T1 | SNC2E1T1 | SNC2E2T1 | SNC2E3T1 | SNC2E4T1 |

* Sniffer probes with flexible nozzle cannot be used with the ASM 310.

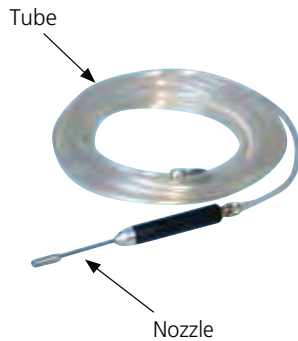

Sniffer probe with short rigid nozzle (9 cm/3.5"):

| Model | Part No |
|---|---------------|
| Tube length 20 m/69.6 feet/787 inches | 802826 |
| Tube length 30 m/96.4 feet/1181 inches | 802827 |
| Tube length 40 m/131.2 feet/1575 inches | 802828 |
| Tube length 50 m/164 feet/1968 inches | 802829 |
| Tube length 60 m/169.8 feet/2362 inches | 802830 |
| Tube length 70 m/229.6 feet/2756 inches | 802831 |
| Tube length 80 m/232.4 feet/3150 inches | 802832 |
| Tube length 90 m/295.2 feet/3543 inches | 802833 |
| Tube length 100 m/328 feet/3937 inches | 802834 |

Sniffer probe with long flexible nozzle (30 cm/18"):

| Model | Part No |
|---|---------------|
| Tube length 20 m/69.6 feet/787 inches | 802835 |
| Tube length 30 m/96.4 feet/1181 inches | 802836 |
| Tube length 40 m/131.2 feet/1575 inches | 802837 |
| Tube length 50 m/164 feet/1968 inches | 802838 |
| Tube length 60 m/169.8 feet/2362 inches | 802839 |
| Tube length 70 m/229.6 feet/2756 inches | 802840 |
| Tube length 80 m/232.4 feet/3150 inches | 802841 |
| Tube length 90 m/295.2 feet/3543 inches | 802842 |
| Tube length 100 m/328 feet/3937 inches | 802843 |

Accessories

C5 Liquid sniffer probe (to be connected to the inlet port of a leak detector)

Temperature coefficient: 7 % per °Celsius.

Standard leak rate: $2 \cdot 10^{-4}$ mbar l/s

Able to measure helium concentration inside water or liquids.



| Model | Flange | Part No |
|--|---------|---------|
| Sniffer probe with membrane | DN 25 | 103592 |
| Sniffer probe with membrane and smooth tube connection | Ø 14 mm | 067678 |

Accessories

C6 Helium spray gun Part number: 109951

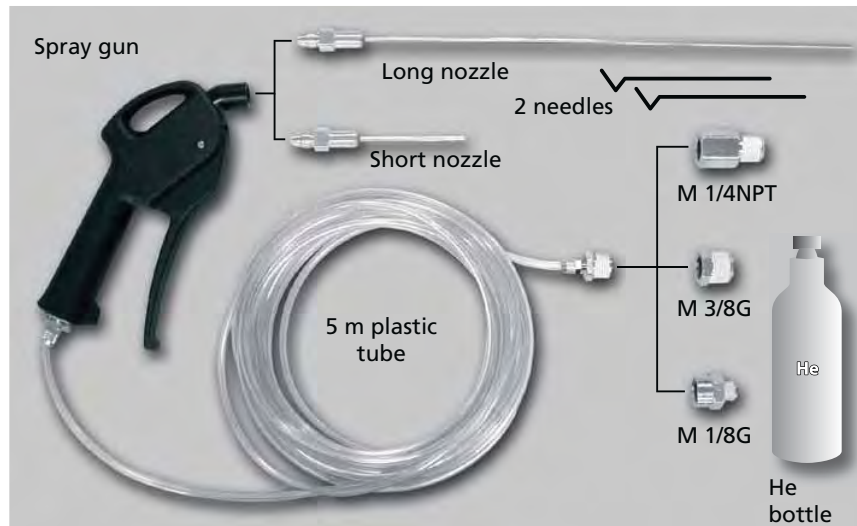

Spraying Helium in order to detect a leak is usually very easy, especially if you need fast and rough detection.

Spraying Helium could also become a technical challenge when you need to pinpoint very fine leaks, especially when they are located in areas with difficult access.

The Helium spray gun is an easy to use and multipurpose tool which allows you to work in various conditions of test:

- Multi standard: thanks to the 3 different adapters to be connected to the Helium bottle (M 1/4 NPT, M 3/8G and M 1/8G).
- Multi purpose: thanks to the 2 nozzle lengths of 80 mm / 3.14 inch and 290 mm / 14.4 inch.
- Standard leak mode: for quick and rough leak tests.
- Fine leak mode.

The Helium spray gun is provided with 2 standard needles which allow the adjustment of the Helium flow at the outlet of the nozzle.

Accessories

C7 Locking clamp DN 40 KF

Part number: **118801**

Like classical clamp, the locking clamp allows to fix an accessory: however, you must use a special tool delivered with to open/close the clamp.



Fixing ring detail



Special tool use

C8 Bombing chambers

| Model | DN Flange | Part No |
|--|-----------|---------------|
| Bombing chamber 10 bars (Ø 150 - L 200 - Vol.: 3.5 l) | - | 786396 |
| Bombing chamber 25 bars (Ø 150 - L 200 - Vol.: 6.4 l) | - | 786397 |



C9 Inlet filters Complete inlet filters



| Model | DN Flange | Part No |
|--------------------|--------------|---------------|
| 20 µm inlet filter | 25/25 | 105841 |
| 20 µm inlet filter | 40/40 | 105842 |
| 20 µm inlet filter | 40/25 | 105843 |
| 5 µm inlet filter | 25/25 | 105844 |
| 5 µm inlet filter | 40/40 | 105845 |
| 5 µm inlet filter | 40/25 | 105846 |

Accessories

Spare parts for inlet filters

| | Model | DN Flange | Part No |
|---|---|----------------------|----------------------------|
|  | stainless steel mesh filter 70 µm stainless steel mesh filter 70 µm stainless steel mesh filter 70 µm | 16 25 40 | 072721 072857 067636 |
|  | 20 µm inlet filter 5 µm inlet filter | Ø 114 mm Ø 114 mm | 105847 105848 |
|  | O'ring, dia. 5 mm | Ø 114 mm | 082152 |

Accessories

S1 Transport case Part number: 119594



S2 Transport cart Part number: 114820



CAUTION

Compulsory fixing to the leak detector.

Accessories

S3 Bottle holder

Part number: **118444**

The bottle holder allows to fix a helium bottle of \varnothing 180 mm maximum on the leak detector (example: B5 or B11 type).



The helium bottle is not supplied with bottle holder: it is at the customer's charge.



Bottle holder fixed on the leak detector





Bottle holder equipped with helium bottle

Installation: Refer to  **B 240**.

S4 Bluetooth

Part number: **P0482E1**

Description  **A 300**.

Installation and use: refer to  **B 308**.



Accessories

S5 Input/Output board

37 pin input/output board

| | ASM 380 | ASI 30 |
|-------------|---------|--------|
| Part number | 118088S | 118577 |

Description  A 300.

Installation and use: refer to  B 308.

Check compatibility between « 37 pin input/output board » accessory and the other interfaces in option/accessory: refer to  B 300.

37 pin input/output board with Wi-Fi

| | ASM 380 | ASI 30 |
|-------------|---------|--------|
| Part number | 118089S | 118578 |

Description  A 300.

Installation and use: refer to  B 305.



Check compatibility between « 37 pin input/output board with Wi-Fi » accessory and the other interfaces in option/accessory: refer to  B 300.

37 pin input/output board with Ethernet

| | ASM 380 | ASI 30 |
|-------------|---------|--------|
| Part number | 118090S | 118579 |

Description  A 300.

Installation and use: refer to  B 306.



Check compatibility between « 37 pin input/output board with Ethernet » accessory and the other interfaces in option/accessory: refer to  B 300.

Accessories

S6 Profibus board

Part number: **118581**

Description  **A 300.**

Installation and use: refer to  **B 307.**

Check compatibility between « Profibus board » accessory and the other interfaces in option/accessory: refer to  **B 300.**

S7 Industrial control panel

Industrial control panel with ½ 19» rack format is available with 3 different lengths cables linking the electronic module and the control panel: 1.8 m, 5 m or 10 m.

| Model | Part No |
|--|----------------|
| ½ rack industrial control panel (only) | 119100S |
| Cable of 1.8 m length | 114435 |
| Cable of 5 m length | A458735 |
| Cable of 10 m length | 110881 |

S8 Sniffing kit

Part number: **104757**

It is composed of:

- a sniffing cell,
- 2 quick connectors (male and female),
- connection accessories,
- pipe.



This option allows working in sniffing mode.

Kit installation:  **B 240.**

The option use requires a primary pumping associated to the leak detector: at the customer's charge.

Sniffing probe required in sniffing mode is not delivered in the kit: at the customer's charge.

Accessories

S9 2005 SI Pump This accessory allows adding a primary pumping to the leak detector. This primary pumping connected to the "Sniffing kit" option/ accessory, will allow working sniffing mode.

Characteristics

- 2 stages pump
- flow rate: 4 m³/h
- connector for LDS
- voltages should be specified when ordering
- supplied without connecting accessories.
- accessories for primary pump:
 - filter OME 25 S – P/N **104200**
 - filter cartridge – P/N **068304**

Part No to command

205 SIX X X M

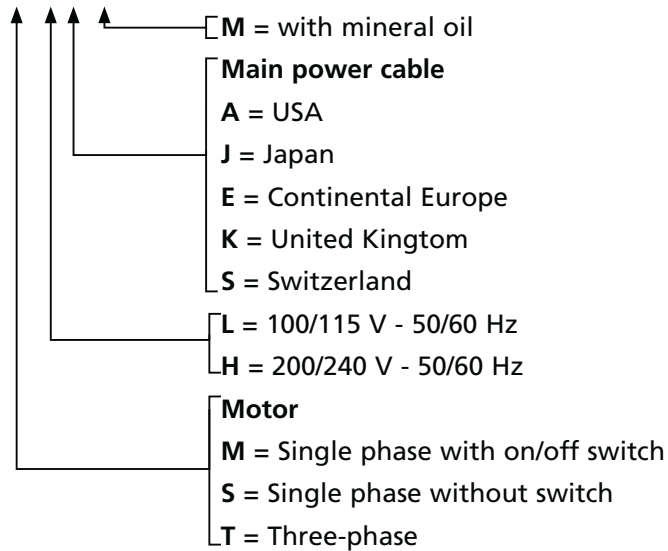

Accessories

S10 Interface extension kit

Part number: **119428**

The « Interface extension kit » allows having 3 screw plug connectors on the ASI 30 instead of a 37 pins Sub D connector.

It is composed of:

- an interface extension board,
- a kit with screws and fixing braces
- 3 female connectors.

Kit installation:  **B 240.**

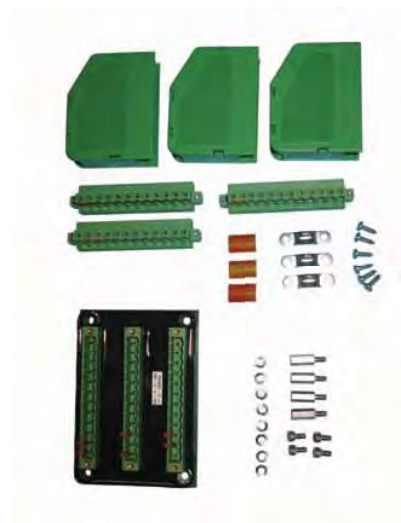

S11 Power supply cords

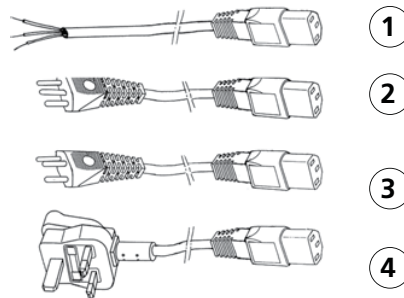

| | Designation | Part No |
|---|---|---------|
| ① | Cable, main power; 2 m - without plug | 104559 |
| ② | Cable, main power; 2 m - Italy | 104758 |
| ③ | Cable, main power; 2 m - Switzerland | 103718 |
| ④ | Cable, main power; 2.5 m - United Kingdom | 104411 |

Accessories

S12 Measurement gauge

Gauge part number: PT R26 950

Gauge cable part number: PT 448 250 -T

ASI 30 electronic module is set to be used with TPR 280 gauge.

Measurement range: $5 \cdot 10^{-4}$ to 1000 mbar

Flange: DN 16 ISO-KF

TPR 280 gauges with other flanges: refer to Pfeiffer Vacuum book.



Technical characteristics

| | Measurement range(*) (Helium) | | Crossover pressure (at inlet) | |
|--|---|---|----------------------------------|------|
| | mbar l/s | Pa m ³ /s | mbar | Pa |
| Gross Leak test mode | $8 \cdot 10^{-7}$ to $1 \cdot 10^0$ | $8 \cdot 10^{-8}$ to $1 \cdot 10^{-1}$ | 15 | 1500 |
| Normal test mode | $5 \cdot 10^{-9}$ to $3 \cdot 10^{-4}$ | $5 \cdot 10^{-10}$ to $3 \cdot 10^{-5}$ | 10^{-1} | 15 |
| High Sensitivity test mode | $9 \cdot 10^{-11}$ to $2 \cdot 10^{-4}$ $5 \cdot 10^{-12}$ with zero function | $9 \cdot 10^{-12}$ to $2 \cdot 10^{-5}$ $5 \cdot 10^{-13}$ with zero function | $2 \cdot 10^{-2}$ | 2 |
| Sniffing test mode | $5 \cdot 10^{-7}$ to $1 \cdot 10^{-1}$ | $5 \cdot 10^{-8}$ to $1 \cdot 10^{-2}$ | sniffer probe at atm. pressure | |
| Response time (Inlet port blanked off) | | | < 1 s | |

(*) Zero function not activated, in standard conditions (20 °C, 5 ppm He ambient, degassed detector).

Helium pumping speed: High Sensitivity test mode

| | |
|---------------|-------|
| At inlet port | 7 l/s |
|---------------|-------|

Technical characteristics according to AVS 2.3 or EN1518 or ISO 3530 standard,

Roughing primary pump characteristics:

| | |
|------------------------------------|----------------------|
| Hybrid pump pumping speed (in air) | 35 m ³ /h |
|------------------------------------|----------------------|

Analyzer cell (Spectro):

| | |
|-------------------------|--|
| Analyzer cell design | self protected 180° magnetic deviation mass spectrometer |
| Analyzer cell filaments | 2 Iridium filaments |
| Emission current range | 0.2 to 2 mA |

Display:

| | |
|-----------------------------------|---|
| Inlet port pressure display range | 10^3 to 10^{-3} mbar / 10^5 to 10^{-1} Pa |
|-----------------------------------|---|

Set points adjustments:

85 dB modulated and adjustable audio signal

| | |
|------------------------------------|--|
| Hard vacuum Audio signal set point | Adjustable throughout the entire measuring range |
| Sniffing Audio set point | Adjustable throughout the entire measuring range |

Technical characteristics

Start-up time (at 20 °C)

| | |
|--------------------------|---------------------|
| Without auto-calibration | < 4 min 15 s ± 10 % |
| With auto-calibration | < 5 min 30 s ± 10 % |

Time to reach test mode (*) :

| | inlet port blanked-off | connected to 4 l volume | connected to 50 l volume |
|----------------------------|---------------------------|----------------------------|-----------------------------|
| Gross Leak test mode | 2 s | < 4 s | < 35 s |
| Normal test mode | 3 s | < 6 s | < 70 s |
| High Sensitivity test mode | 4 s | < 10 s | < 95 s |

(*) the indicated time are reached for systems to be tested degazed beforehand.

Miscellaneous:

| | |
|--|-----------------------|
| Power voltage | 90 - 240 V ± 10% |
| Power frequency | 50/60 Hz single phase |
| Power consumption (maximum) | 1500 VA |
| Start-up temperature | 10 to 35 °C |
| Ambient operating temperature | 10 to 35 °C |
| Storage temperature | - 25 to 70 °C |
| Noise level (at 1 meter; audio alarm not operational, stand-by mode, after 1/2 h of use) | 53 dBA |
| House protection level | IP 20 |
| Inlet | DN 40 ISO-KF |
| Humidity max. (at 40 °C) | 95 % |
| Weight (only detector) | 110 kg/242.3 lbs |
| Maximum weight (detector, accessories, parts, ...) | 150 kg/330.4 lbs |

Dimensions (inch)

CAUTION

Let a free space of 10 cm (4 inches) minimum all around the leak detector.
Store nothing under the detector.

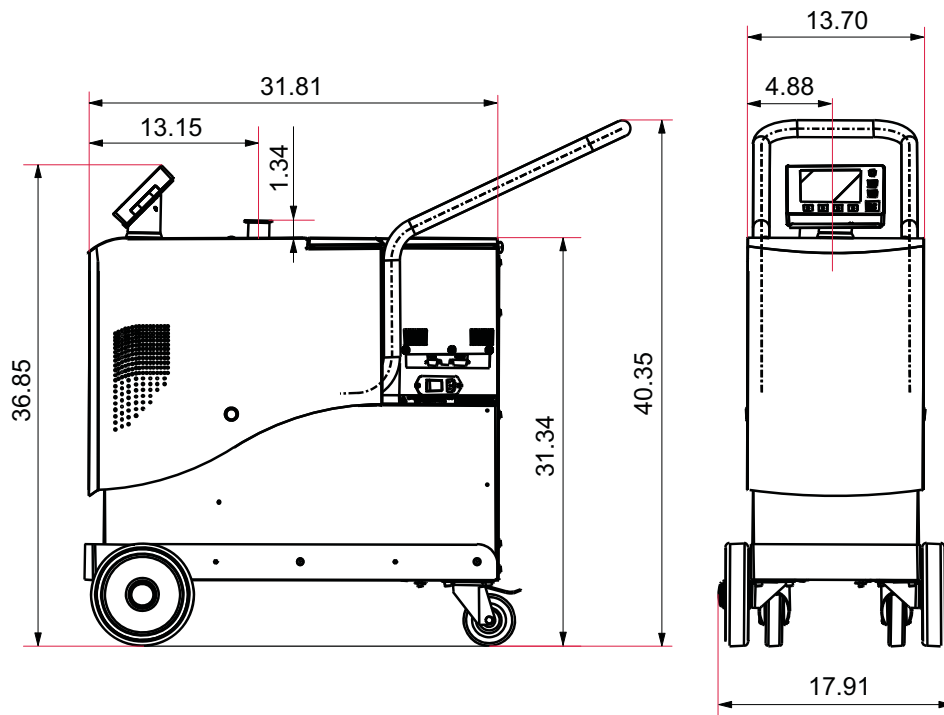



Installation

ASM 380 - Operating instructions Detailed contents

Preliminary remarks Throughout this operating manual, you could find this type of message **""Setting"" menus arborescence**  **C 600"**: it refers to a specific chapter of the operating manual. Please read it for further information.

| | |
|--------------|---|
| B 100 | <i>Safety instructions</i> |
| | <ul style="list-style-type: none">- Overview- Storage- Unpacking- Installation- Operation- Maintenance |
| B 110 | <i>Unpacking/Packing - Storage - Handling</i> |
| | <ul style="list-style-type: none">- Unpacking at the receipt- Packaging for shipment- Remote control fixing- Hose holder fixing- Storage- Handling |
| B 111 | <i>Supplies delivered with the leak detector</i> |
| | <ul style="list-style-type: none">- Supplies |
| B 112 | <i>Labels on/inside the leak detector</i> |
| | <ul style="list-style-type: none">- Packaging label- Detector labels- ACP 40 Primary pump labels |
| B 200 | <i>Neutral gas purge and inlet vent connection</i> |
| | <ul style="list-style-type: none">- Purpose- Connection to the leak detector- Gas characteristics |
| B 220 | <i>Customizable rear panel</i> |
| B 240 | <i>Accessories installation</i> |
| | <ul style="list-style-type: none">- Bottle holder kit- Bluetooth- Wireless remote control (RC 500 WL)- Input/Output board kits |



Installation

ASM 380 - Operating instructions Detailed contents

B 300***Controlling detector***

- Proposed interfaces
- Interfaces mechanical compatibility
- Interfaces software compatibility
- Bluetooth - Input/output board - Profibus board installation
- Data export

B 301***RS 232***

- Purpose
- Connection
- Use

B 302***15 pin Interface***

- Purpose
- Connection
- Use
- Analog Output

B 303***37 pin Input/Output interface***

- Purpose
- Connection
- Input/output surveillance
- Internal 24 V or external 24 V power supply ($\pm 10\%$)
- Inputs (Orders)
- Digital outputs (signals)
- Parameters access
- Serial link 1 / Serial link 2
- I/O connector

B 304***USB***

- Purpose
- Connection
- Compatibility with the other interfaces
- Preliminary conditions
- USB setting

B 305***Wi-Fi***

- Purpose
- Network
- Connection
- Compatibility with the other interfaces
- Preliminary conditions
- Use with a detector
- Use with a PDA
- Wi-Fi setting



Installation

ASM 380 - Operating instructions Detailed contents

B 306

Ethernet

- Purpose
- Connection
- Compatibility with the other interfaces
- Preliminary conditions
- Use with a PC
- Ethernet settings

B 308

Bluetooth



- Definition
- Installation
- Compatibility with the other interfaces
- Preliminary conditions
- Use with a PC
- Use with a PDA

B 400

Starting up / Switching off of the leak detector

- Connecting the detector to the installation
- Use position
- Storage
- Control panel fixing
- Hose holder fixing
- Cover locking
- Ventilation
- Basic vacuum rules for the installation connecting
- Use conditions
- Starting-up
- Switching off recommended

Safety instructions

| | |
|--|---|
| CAUTION | Indicates a potentially hazardous situation which, if not avoided, could result in property damage. |
|  CAUTION | Indicates a potentially hazardous situation which, if not avoided, could result in moderate or minor injury. It may also be used to alert against unsafe practices. |
|  WARNING | Indicates a potentially hazardous situation which, if not avoided, could result in death or severe injury. |
|  DANGER | Indicates an imminently hazardous situation that, if not avoided, will result in death or severe injury (extreme situations). |

Overview

Before switching on the appliance, study the operating manual and make sure you follow the safety instructions it gives. You can recognise these by the 'Caution', 'Warning' and 'Danger' symbols. Good practice tips and manufacturer's recommendations are in a blue box.

The performance and operational safety of this product are guaranteed provided it is used normally in the operating conditions defined in this manual.

It is the customer's task to:

- train operators to use the product if they do not speak the language the manual is written in,
- ensure operators know the safe practices to apply when using the product.

We took care to provide you with a clean appliance. To keep it in this condition, unpack it only in its final place of use.

For emergencies and breakdowns, contact the manager of your local service center (see addresses at back of manual).

Make sure the equipment shows no sign of transport damage. If it has been damaged, take the necessary steps to record this with the carrier and inform the manufacturer. In all cases, we recommend keeping the packaging (reusable materials) for further transport of the equipment or for prolonged storage.

Safety instructions

Our products are designed to comply with current EEC regulations. Users making their own modifications to the product are liable to break its compliance with these regulations, degrade its EMC (electromagnetic compatibility) rating, and make it unsafe to use. The manufacturer declines all liability for the consequences of such operations.

CAUTION

The product's EMC rating is obtained on the understanding that it is installed in compliance with EMC rules.

Of special note: in environments that are prone to emit interference,

- use shielded cables and connections on interfaces,
- put earthed screening on the power supply line, from the power source up to 3 meters (10 ft) from the product cable entry.

Storage

When storing the detector, please note that we guarantee the reliability of our equipment for three months in normal storage conditions (see operating manual for storage temperatures). Beyond this period, factors like temperature, humidity, or salt in the air can lead to deterioration of 'sensitive' items (elastomer, lubricant, etc.).

For storage longer than 3 months, follow the instructions in the operating manual.

Unpacking

Heavy detector

This product needs special handling precautions due to its weight. It should be removed from its crate only by staff trained in heavy materials handling:

- make sure the detector is stripped of all excess weight (accessories, customization, etc.) and the side covers are fastened,
- use the lifting rings provided with the product. The maker can not be held liable for the consequences of using other rings.
- screw the rings firmly home into the holes, provided, facing in the right direction to accept the slings,
- never lift the detector by means of a single lifting ring,
- the sling must not form an angle of more than 45 ° from vertical.

Installation

WARNING

Risk of tilting.

Although the appliance meets EEC safety regulations (normal range $\pm 10^\circ$), it is advisable to guard against the risk of tilting during handling, installation, and use.

ASM 380 detector.

When the detector is placed on a gradient of more than 3 ° (6 %), it can drag the operator along due to its heavy weight:

- use castors to move it,
- locate it on flat, hard ground,
- do not push it sideways or press on its side faces,
- do not leave objects leaning on the side of it.

The detector is not designed to carry people or loads and is not for use as a seat or step.

Safety instructions

Installation (cont.)

In leak detectors fitted with atmospheric air purging, avoid performing detection operations in non ventilated rooms. The helium concentration may be too high.

CAUTION

The leak detector must be installed on a horizontal flat surface and never laid on its side. Some models cater for other positions; these are described in the operating manual.

CAUTION

The leak detector is Class 1 equipment and therefore must be earthed. The user must check the electrical installation to which the leak detector is connected:

- it must comply with current standards (IEC 364),
- it must have a standards compliant earth wire, properly connected to earth.

WARNING

Electric shock hazard on touching.
When the main isolator is switched to the «0» position, items located between the mains connection and the isolator are still under mains voltage. Disconnect the mains cable from all power sources before commencing any maintenance work on the product.

WARNING

Electric shock hazard.
Some components have capacitors charged to over 60VDC. When power is switched off, they keep their charge for a time. Residual voltages from the filter capacitors can cause electric shocks all the way back to the mains plug. Wait 5 minutes after power-off before commencing any work on the appliance.

WARNING

A helium leak test must be performed in environmental conditions bearing no risk to the user or equipment.
The user and/or OEM are ultimately responsible for ensuring proper safety conditions apply to the working product. The manufacturer has no control over the type of gas the detector is used with. Parts tested, equipment used, and the plant itself must show no trace of aggressive, chemical, corrosive, inflammable, reactive, toxic, explosive substances, neither condensable vapors, even in tiny quantities.
These are hazardous substances, and the process user must take responsibility for applying all relevant safety instructions in accordance with the legislation in effect at the site.
The detector's nitrogen purge system is not intended to dilute these gases. The manufacturer can not be held liable and the guarantee is void if the detector is used while these gases are present.

WARNING

Lock out (LO/TO) of nitrogen purging circuit.
The user will need to provide a dedicated Nitrogen circuit, fitted with a manual valve, that can be locked out within a radius of 3 m (10 ft) of the equipment.

Safety instructions

Operation

CAUTION

ASM 380 detector

This leak detector must not be used without its purge system. The user must make sure the purger is present and working properly.

The manufacturer shall not be held liable for any damage to the product and the guarantee is void if the purge does not work.

WARNING

The products are factory tested to ensure they will not leak in normal operating conditions. It is the user's responsibility to ensure this level of leak tightness is maintained.

DANGER

Explosion hazard.

To detect leaks using «hydrogen» tracer gas, always use hydrogenated nitrogen (95 % N₂ and 5 % H₂) (see chapter A of operating manual).

CAUTION

If the appliance is used in applications where dust or solid particles are present, we advise protecting it with an inlet filter (see section A of the operating manual).

Always use clean pipes and fittings in the pumping installation.

CAUTION

Make sure all parts and chambers connected to the inlet of our products can withstand a negative pressure of 1 bar below atmospheric pressure and that they are impervious to damage from vacuum (seals, etc.).

CAUTION

The inlet pressure must be no higher than atmospheric pressure. Too high a pressure can damage the product

WARNING

Remove the blanking plates on the inlet and exhaust orifices. These are to prevent foreign bodies entering the pump during transport and storage.

CAUTION

Make sure the exhaust pressure does not exceed 1200 mbar (absolute). Too high a pressure can damage the appliance.

After connecting the appliance to the pumping line, check for leaks along the whole of the line to ensure proper connections have been made (pump, pipes, valves, etc.).

Safety instructions

Operation (cont.)

CAUTION

Leak detectors fitted with oil seal roughing pumps. These pumps come without oil, which is delivered in separate drums. The material safety sheet for the oil is available upon request. Always wear gloves and goggles when filling the pumps with oil.

DANGER

The voltages and currents in use can induce electric shock. Isolate and lock out power to the appliance before maintaining it or removing the cover. Only skilled, authorized people may carry out maintenance work.

CAUTION

Risk of seizing
Avoid moving or applying shock to a running detector.
Portable detectors: avoid rotating the appliance about an axis perpendicular to the axis of rotation of the high vacuum pump.

CAUTION

ASM 380 detector.
Nipping hazard:
- keep hands away from the sides when opening the cover,
- keep hands away from the front of the cover when closing it.
Laceration hazard:
Do not move the appliance by holding the bumper bar. Use the handle provided.

Maintenance

The outside of the appliance and control box can be cleaned with a lint free wiper. Avoid using cleaning products that deteriorate printed surfaces and self adhesive labels. All other cleaning operations must be done by our service centers.

Whenever you return the product to an adixen repair service center, you must comply with the requirements of the «Procedure for returning adixen products» and fill in the safety questionnaire available in appendix chapter of the operating manual.

Safety instructions

Maintenance (cont.)

Do not eliminate maintenance waste via standard disposal channels. Have it destroyed by a qualified company if necessary.



Decontamination – product dismantling

According to the regulations 2002/96/CE about Waste of electrical and electronical equipments, and 2002/95/CE about Restriction of Hazardous substances, the manufacturer provides a recycling paid service for the end-of-life of waste electrical and electronic equipment.

Any obligation of the manufacturer to take back such equipment shall apply only to complete not amended or modified equipment, using adixen Vacuum Products original spare parts, delivered by adixen Vacuum Products, containing i.e. all its components and sub-assemblies.

This obligation will not cover the shipping cost to an adixen take back facility. Before returning the product, fill in the safety form available in appendix of the operating manual. Attach it to the product before shipping to the service-repair office closest to you.

CAUTION

Leak detectors fitted with oil seal roughing pumps.

We advise draining the pump prior to any transport of the equipment.

Always wear gloves and goggles when draining the pumps.

Do not put waste oil down the drain. Have it destroyed by a qualified company if necessary.

WARNING

Maintenance must be performed by a skilled maintenance operator trained in the relevant health and safety aspects (EMC, electrical hazards, chemical pollution, etc.).

Isolate the product from all energy sources (mains electricity, compressed air, etc.) before starting work.

Major overhauls must be performed by qualified staff who have received training from the manufacturer, especially when it comes to handling the fluids inside the detector (see instructions in operating manual).

WARNING

The products are designed to avoid subjecting users to heat hazards. Specific operating conditions can nevertheless exist that require extra caution from users due to the high temperatures generated (outer surfaces > 70° C):
Wear protective gloves to work on the appliance, especially during maintenance.

Unpacking/Packaging - Storage - Handling

Unpacking at the receipt

As soon as equipment receipt unpack it carefully.

Do not discard the packaging: keep it for a possible transport.

In the event of an anomaly, take the necessary actions with the carrier and if necessary contact us.



Check:

- On the packaging, the model number and the serial number (1).
- On the packaging, the 3 safety indicators (2).
- 2 shock indicators (1 inside and 1 outside) of the packaging (3).



(1) On the side



(2) At each end



(2) On the top



(3) Inside



(3) On the side

Unpacking/Packaging - Storage - Handling

Unpacking at the receipt (Cdt)

- Take off assembly straps, then the box to the top without damage.



- Remove the operating manual (1), the maintenance kit (2) and the power cables (3) delivered with the detector.



- Remove the top foam. Free the leak detector without damaging the yellow protection cover.

Unpacking/Packaging - Storage - Handling

Unpacking at the receipt (Cdt)

CAUTION

Fix the 2 lifting rings to 2 slings (length: 70 cm / 27.5 inches minimum) by the rule book and by an authorized person: lifting rings must be placed in the slings axes.

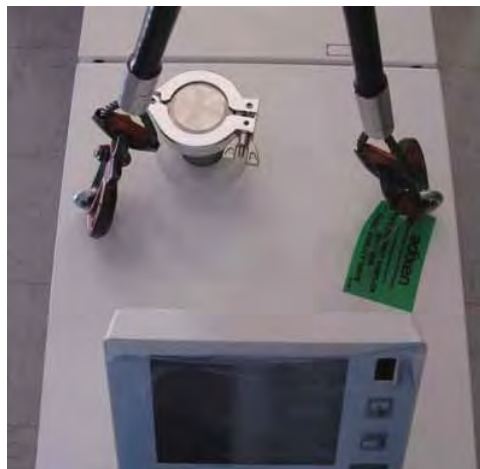

CAUTION

Never lift the leak detector with only 1 lifting ring and always use those delivered with the detector.

- Lift the detector with the hoist.
- Remove the pallet with the protection cover and the lower foam.



- Remove front wheels protective film.
- Put the detector back.



Unpacking/Packageing - Storage - Handling

Unpacking at the receipt (Cdt)

- Remove the lifting rings and place them in the storage box. White masks, delivered with the detector in the storage box, could be placed in place of rings.



Packageing for shipment

CAUTION

- Before lifting the detector, check that:
 - Storage box and hoses storage box (1) are empty.
 - 4 cover screws (2) are present and screwed (tightening torque = minimum 6 Nm).

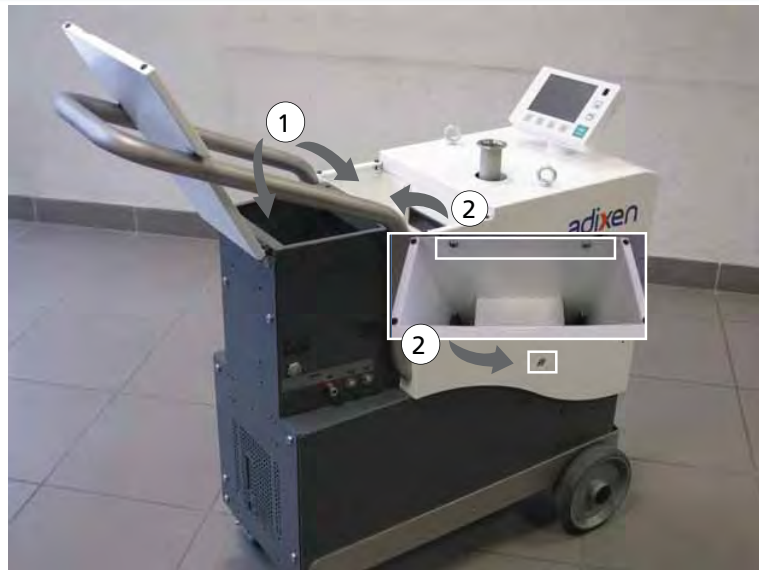

If the leak detector is equipped with bottle holder accessory, accessories in the inlet port or other customization, remove it (them) before beginning detector packaging.

Unpacking/Packageing - Storage - Handling

Packaging for shipment (Cdt)

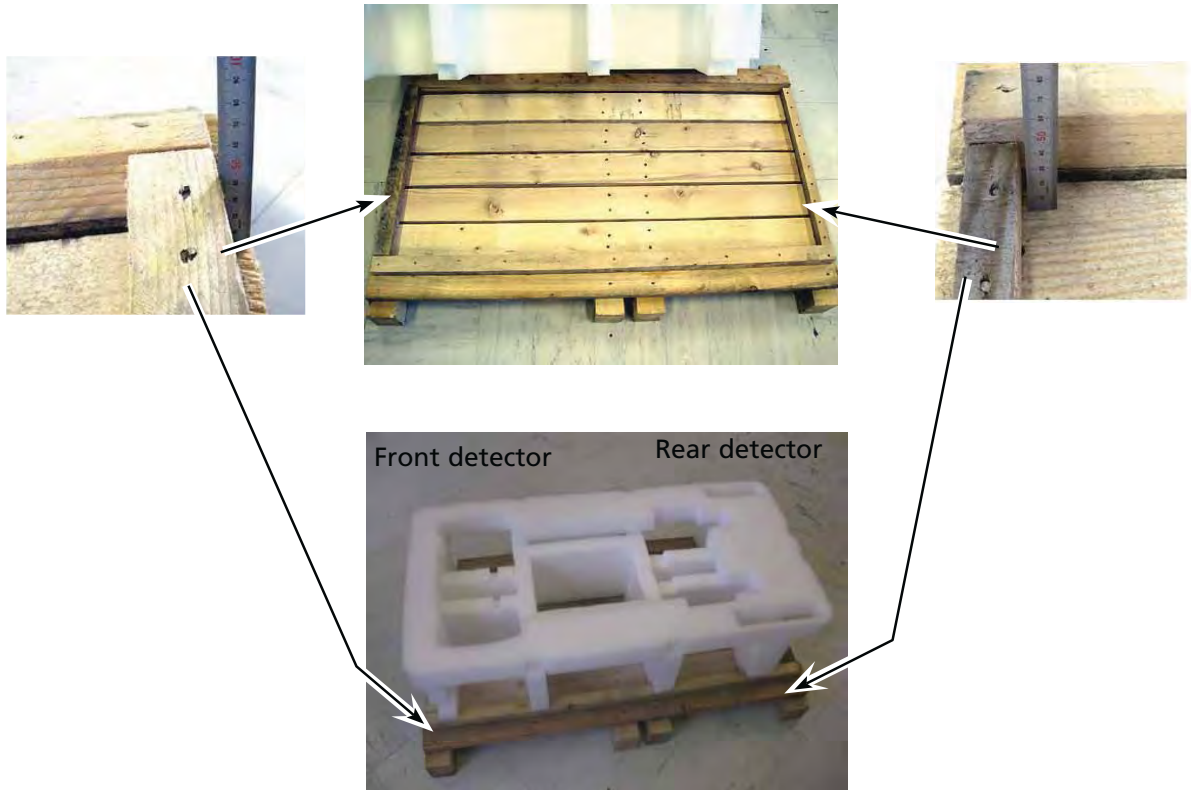

Lower foam direction to respect on the pallet.

Unpacking/Packaging - Storage - Handling

Packaging for shipment (Cdt)

- Fix the 3 lifting rings on the leak detector: refer to the instructions in the "Unpacking" chapter.
- Place the control panel in such a way that it is parallel to the detector front side.



- Lift the detector: refer to the instructions in "Unpacking" chapter.
- Wrap the detector with the protection cover.



- Place the leak detector on the foam: the handle must be in the same side as maintenance kit and the power cable spaces.



- Remove the 3 lifting rings.
- Fix the plastic cover.

Unpacking/Packaging - Storage - Handling

Packaging for shipment (Cdt)



- Place the upper foam.



- Place the box on the ensemble.



- Stick 2 tilt indicators (1 inside and 1 outside).



Unpacking/Package - Storage - Handling

Packaging for shipment (Cdt)

- 3 straps are necessary to close the box.



Remote control fixing

- Refer to  B 400.

Hose holder fixing

- DN 40 KF hose holder (delivered alone without centering ring, o'ring and clamp) allows to fix the hose connecting the inlet detector to the installation to be tested, during a moving or an extended storage and to keep under vacuum inlet detector and hose.



- The holder is fixed instead of a lifting ring: unscrew one lifting ring and screw the holder at its place.



Storage

CAUTION

For prolonged storage, factors such as humidity, temperature, saline atmosphere, etc.. may damage the detector elements.
Seal kits must be stored away from heat and light (direct sunlight ultraviolet radiation) in order to prevent any elastomers setting.

- Contact your Customer Center for more informations.
- Before any starting up or after an extended storage above 6 months, we advise to change all o'rings (contact your Customer Center).
- Refer to the switching off recommended procedure:  B 400.

Unpacking/Packaging - Storage - Handling

- Handling**
- Follow the safety instructions ( B 100).
 - To move the leak detector, follow instructions listed in "Unpacking" chapter.

CAUTION

If the cover is removed, never apply mechanical actions to the internal calibrated leak (example: don't move the detector by pulling on the calibrated leak). Before lifting the detector, check that the storage box is empty, the 4 cover side fixation screws are present and screwed, and remove the bottle of bottle holder if installed.

Supplies delivered with the leak detector

Supplies The leak detector is delivered with the following parts:

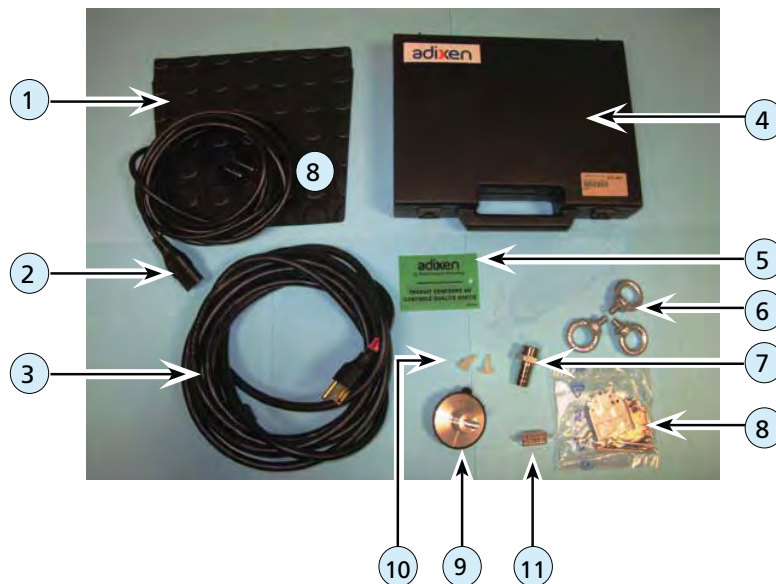

| Designation | | Designation | |
|-------------|--|-------------|--------------------------------------|
| 1 | Groundsheet (in the storage box) | 7 | Exhaust nozzle |
| 2 | Europe power cable | 8 | Sub D connector cover (15 pins male) |
| 3 | USA power cable | 9 | Hose holder |
| 4 | Maintenance kit | 10 | 2 white masks |
| 5 | Quality control label | 11 | Sub D connector (15 pins male) |
| 6 | 3 lifting rings (with warning label not illustrated) | | |

Labels on/inside the leak detector

- Packaging label** ■ Printed on the both packaging sides, this label indicates where are the packaging instructions in the operating manual.



Label on the detector packaging

- Detector labels** ■ Lift the cover to see labels ① and ②.

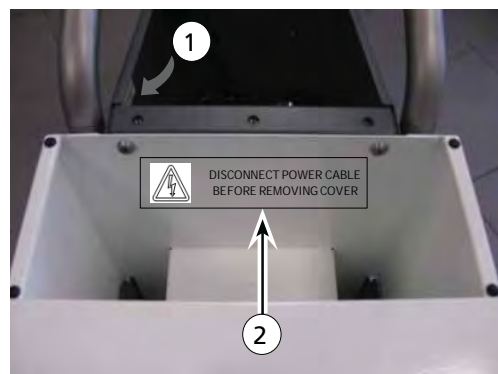

Labels on/inside the leak detector

- Located inside storage box, the identification label ① indicates:
 - detector P/N
 - its serial number
 - its index.



- Serial number structuration

HLDxxzzzzz:

- HLD = leak detector
- xx = detector manufacturing year
- zzzzz = detector serial number



- Located near detector identification label, this label indicates interfaces which are installed in the detector, as well as MAC addresses.



Labels on/inside the leak detector

- Located inside hoses storage box, this label (2) reminds to disconnect the power cable before removing the cover.

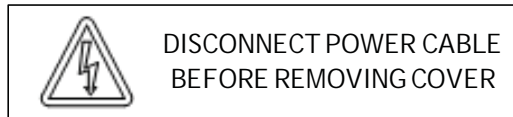

- Located above main power switch, the label (3) indicates that the product has been customized in factory, according to customer order.



- Located below the main power, this label (4) :
 - gives the detector use powers and the maximal power
 - gives the detector net weight
 - indicates that the main power cable must be disconnected before any maintenance operation.
- This label indicates a detector ground point.



Labels on/inside the leak detector

- Located on each delivered lifting ring, this label indicates that the product lifting is regulated: refer to the instructions indicated in the sheet  B 110.

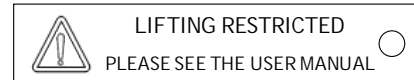

- Located on one lifting ring, this label guarantees that the leak detector has been checked and declared compliant before its shipment to the customer.



ACP 40 primary pump labels



Located on the cover of the pump, this label warns the user against possible risk of injury due to any hand contact with hot surfaces. It states that protective gloves should be used before performing any intervention.

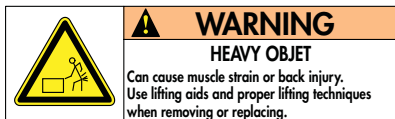

Located on the upper cover, this label indicates that due to its heavy weight, the product should not be handled manually, but always through appropriate handling devices.

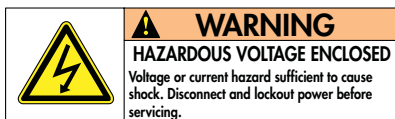

Located on the upper cover, this label indicates that some of the internal parts are energized and could cause electrical shocks in case of contact. It advises to disconnect the pump before any intervention or to properly lock-out and tag-out the equipment breaker before any intervention on the pump.



Located on the upper cover, this label informs the user that moving parts present inside the pump could cause personal injury, like crushing or cutting. The user must keep all body parts away from moving parts.

Neutral gas purge and inlet vent connection

Purpose

Neutral gas purge

- Used to accelerate the cleanup of the helium background noise in the pumps after detecting a significant leak.
- Make High Sensitivity tests easier due to the reduction and stabilization of the helium background noise.
- As a supplement to the neutral gas purge, use the “He max” function ( C 401) so as not to pollute your detector.

Inlet vent

- It is used for connecting the inlet of the detector and the connected part to atmospheric pressure.
- Could be used to accelerate the cleanup of the helium background noise in the leak detector after detecting a significant leak.

Connection to the leak detector

( B 400)

Neutral gas purge

- If no purge system is connected, the gas purge is connected to the ambient air and maintains permanently an air flow inside the leak detector.
- The neutral gas purge status (open or closed) depends on the software. No parameter can be changed by the operator.

Inlet vent

- The inlet vent status (open or closed) depends on the parameters set by the operator ( C 500).
- If no inlet vent system is connected, the inlet vent is connected to the ambient air.

Neutral gas purge and inlet vent connection

Gas characteristics

Type Dry nitrogen is typically the neutral gas used but you can use any gas on the condition that it is low in helium (concentration ≤ 1 ppm).

CAUTION

Ambient air should not be polluted with helium: no detection in a not airy room.

Quality/purity According to the installation or item to test, the gas should be clean, dry, without dust, and non toxic.

Purge flow ≈ 50 sccm

Use pressure (purge and inlet vent)

- 0 to 0.3 bar relative (≈ 0 to 4.3 psig),
- 1 to 1.3 bar absolute (≈ 15 to 20 psia)

If the purge gas pressure is too high, the inlet valve could always be stay closed.

Customizable rear panel

On the detector rear panel are placed 6 tapped holes (M6). These holes are at user's disposal additional to fix any equipment (briefcase, power cable attachment, sniffing probe attachment, maintenance kit support, ...).

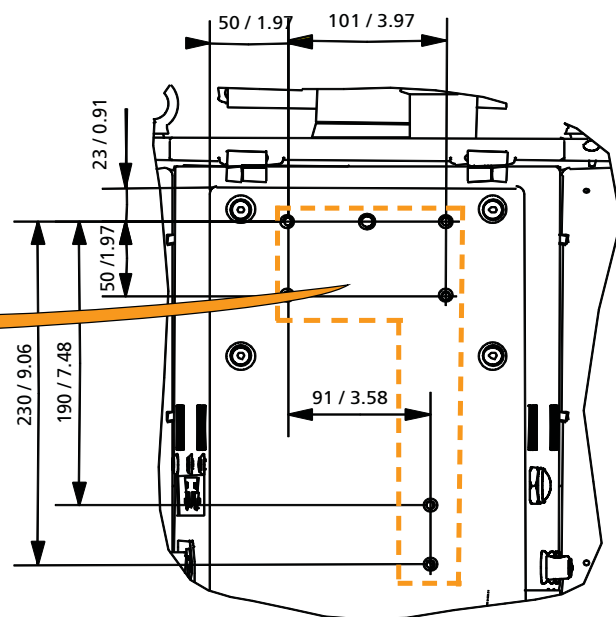
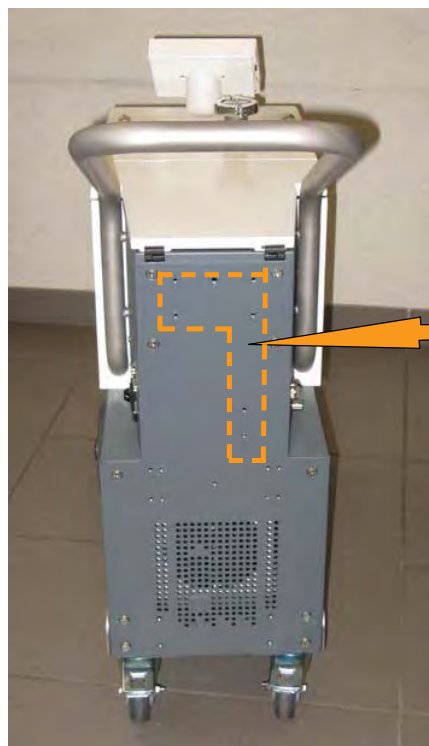
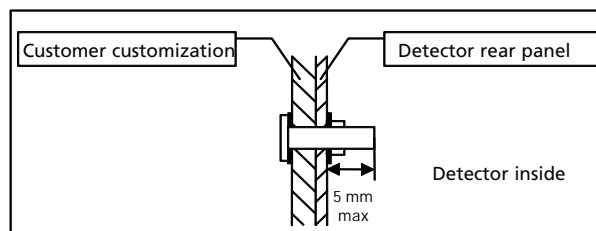

mm / Inch

Accessories installation

Bottle holder kit

Contents

| | Designation |
|---|---|
| ① | Bottle holder |
| ② | Screws and bolts kit (details below) |
| ③ | Bottle strap Ø 145 mm/ 5.70 inches max (example: B5 type) |
| ④ | Bottle strap Ø 180 mm/7.08 inches max (example: B11 type) |
| ⑤ | M6 Key |

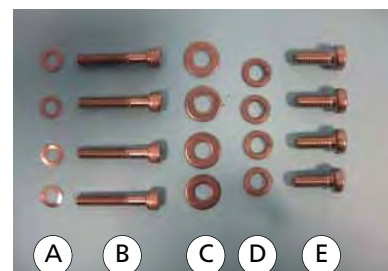
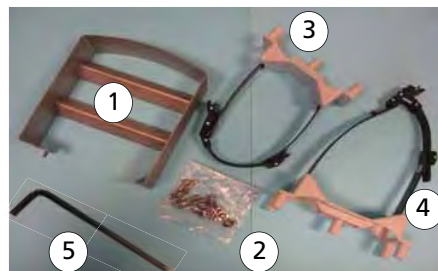

Kit 1 = ① + ②



Kit 2 = ③ + ④ + ⑤

Accessories installation

- Installation**
- Make sure brakes are activated (📖 E 650).
 - Locate the fixing points of bottle rack.

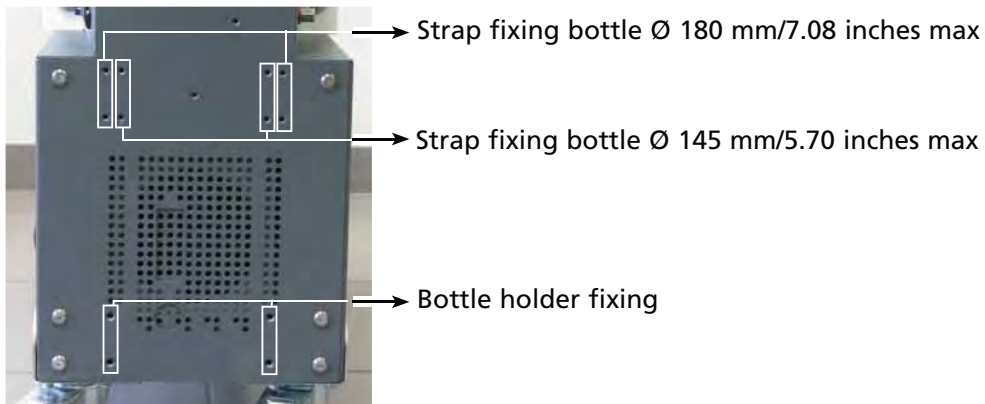

- Fix the bottle holder ① with screws and bolts (kit 2).
- Fix the suitable strap with screws and bolts (kit 1):
 - the strap ③ for a bottle Ø 145 mm/5.70 inches max.
 - the strap ④ for a bottle Ø 180 mm/7.08 inches max.

Bottle fixing

Bottles Ø 180 mm/7.08 inches max can be used: use the suitable strap.

CAUTION

The maximum kit weight equipped with Helium bottle is 25 kg/55 Lbs.

Accessories installation

Bottle fixing (Cdt)



- 1 - Place the bottle (at the customer's charge) on the bottle holder.



- 2 - Open the strap closing system and insert it into the strap locking system around the bottle leaving a little play.



- 3 - With the hand, close the strap closing system.

- 4 - If there is not enough play, press on the strap closing system to give more play.



Helium bottle and pressure reducing valve are at customer's charge.

Accessories installation

Bluetooth The Bluetooth will be installed on the P0411 board.

Place the module on its space.

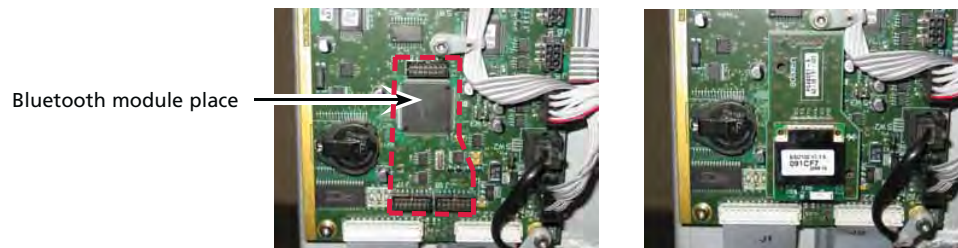

To be recognized by the leak detector, Bluetooth module must be selected in advanced menu (📖 C 406).

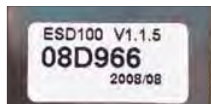

The Bluetooth identification number, different for each Bluetooth, will be necessary for its connection to PDA: note it before putting the cover back.

**Wireless remote control
(RC 500 WL)** See 📖 C 800.

Accessories installation

Input/Output board kits

3 I/O board kits are available:

- I/O 37 pin board,
- I/O 37 pin board with Wi-Fi integrated,
- I/O 37 pin board with Ethernet integrated.

More details: refer to  B 300.

15 pin interface (standard) dismantling

Switch the detector off and disconnect the power supply cable.

Remove the cover and the rear detector panel:  E 110.

Empty the storage box and remove groundsheet.

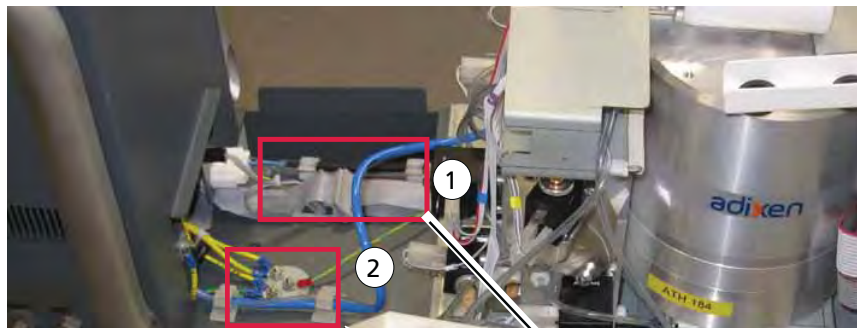

Disconnect the wiring harness of the standard interface (1).

Unscrew ground wire (2) connecting the support plate to the detector frame.

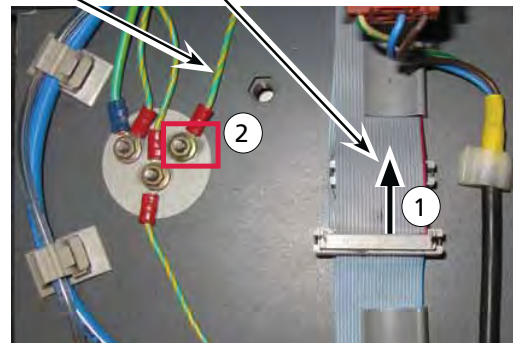

Free the power supply cable (3).

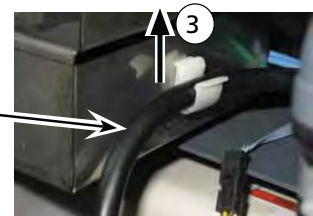
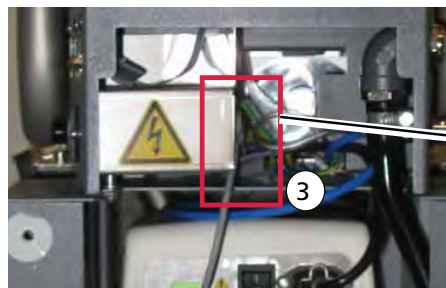

Accessories installation

Unscrew the 6 support plate fixing screws :

- 3 on the detector side,
- 3 in the storage box bottom.

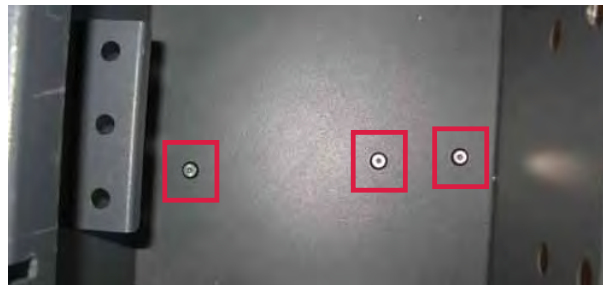

Pull horizontally the support plate out.

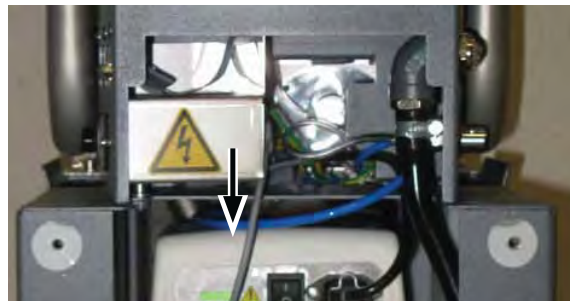

Unscrew the ground wire from the previously support plate removed. Keep it with its screw.



Kits contents

Each kit is delivered with:

- 1 support plate equipped with its I/O board,
- 6 screws and 6 washers to fix the plate on the detector,
- 1 37 pins Sub D male connector to prepare the connection cable (at the customer charge),
- 1 antenna (Wi-Fi only).

Accessories installation

Standard I/O board kit



I/O board with Ethernet kit



I/O board with Wi-Fi kit



Kit installation Screw the ground wire from the previously support plate removed.



Introduce horizontally the support plate ①, with wiring harnesses first: check that wiring harnesses come out ②.

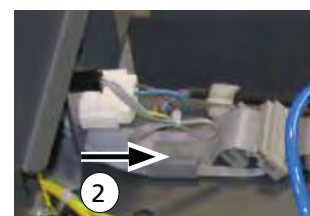
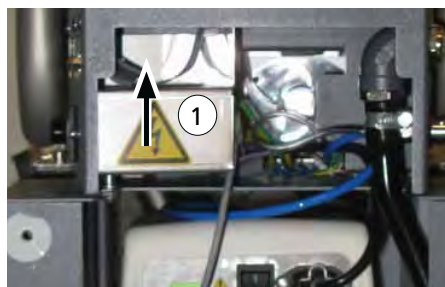

Accessories installation

Screw the 6 support plate fixing screws:

- 3 on the detector side,
- 3 in the storage box bottom.

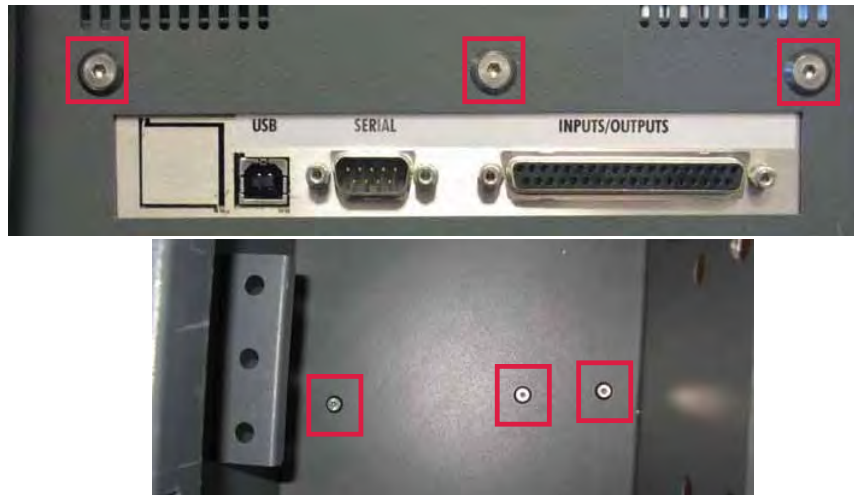

Connect the both wiring harnesses of the I/O interface (1a) and (1b).

Screw ground wire (2) connecting the support plate to the detector frame.

Fix the power supply cable (3).

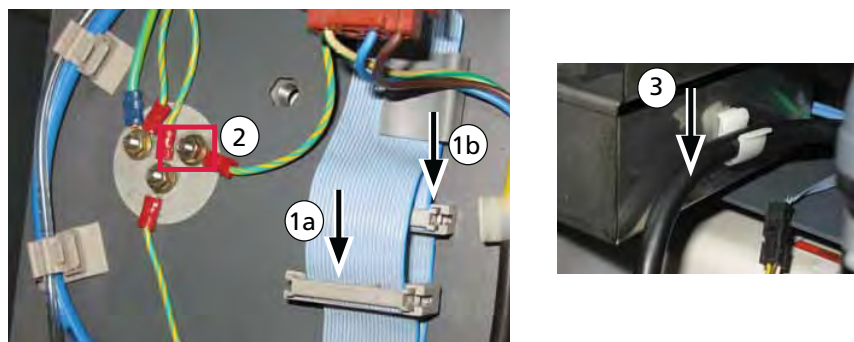





Switch the detector off and disconnect the power supply cable.

Put the cover and the rear detector panel back (E 110) and place the groundsheet in the storage box.

A 37 pins Sub D male connector is delivered to prepare the connection cable (at the customer charge).

Accessories installation

Setting To use USB (standard) interface and Ethernet/Wi-Fi (option) interface:

- Select the interface in the Advanced menu ( C 406).
- Set the interface with the customer installation:
 - USB  B 304
 - Wi-Fi  B 305
 - Ethernet  B 306.

**P0419 board I/O
correspondence with the
other I/O boards of adixen
leak detectors**

3 predefined configurations are available. They correspond, on the whole, to I/O proposed on the different I/O boards which equip adixen leak detectors.

Access:  B 303

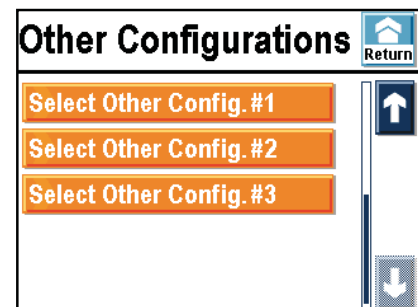

Accessories installation

Below details of the 3 predefined configurations.

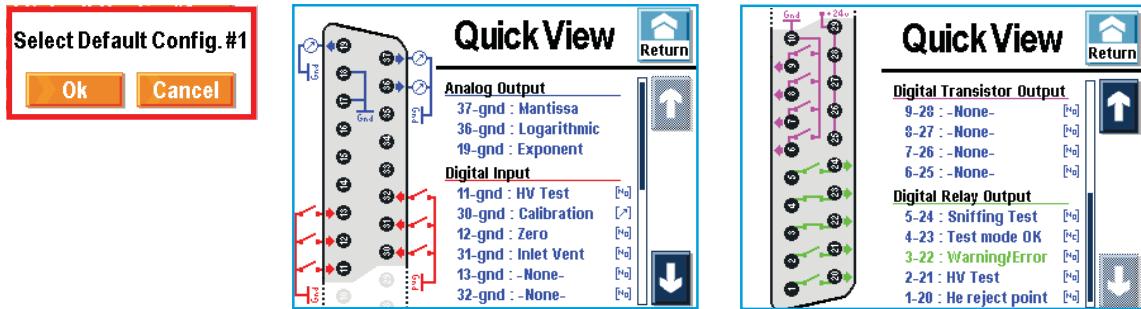

| G = Ground | Detectors with P0307 board ⁽¹⁾ | | Detectors with P0419 board | |
|---|---|--------|----------------------------|--------|
| Internal ground | 1 - 2 - 3 | | 17 - 18 | |
| External ground | 12 - 21 | | 19 - 36 - 37 | |
| Inputs (orders) | | | | |
| Cycle start/stop | 22 | | 11 | |
| Autocalibration sequence start | 23 | | 30 | |
| Zero function start | 24 | | 12 | |
| Vent mode selection | 25 | | 31 | |
| Outputs (signals) | | | | |
| Sniffer mode (LDS) | 4 - 17 | | 5 - 24 | |
| Outside selected test mode | 6 - 19 | | 4 - 23 | |
| Defect | 5 - 18 | | 3 - 22 | |
| Cycle start | 7 - 20 | | 2 - 21 | |
| Helium signal > Reject point | 8 - 9 | | 1 - 20 | |
| Analog output 0 /10 V DC corrected Exponent Helium signal | 2 - 15 | 0/10 V | 19 - G | 0/10 V |
| 0/8 V DC tracer gas analogic output | 1 - 14 | 0/8 V | 36 - G | 0/10 V |
| Corrected Mantissa Helium signal | 3 - 16 | 1/10 V | 37 - G | 1/10 V |

(1) ASM 142 series – ASM 102 S

Accessories installation

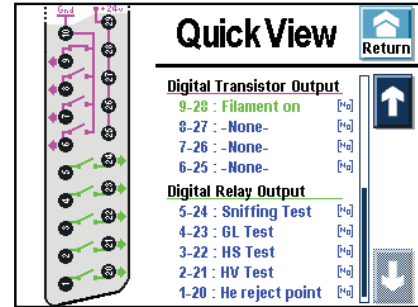
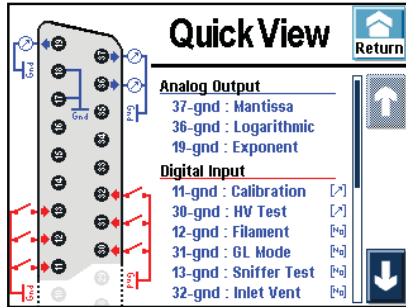

| G = Ground | Detectors with P0344 board ⁽¹⁾ | | Detectors with P0419 board | |
|--|---|--------|----------------------------|--------|
| Internal ground | 15 | | 17 - 18 | |
| External ground | 21 - 24 | | 19 - 36 - 37 | |
| Inputs (orders) | | | | |
| Interface | | | | |
| Contact open: the filament command is valid. | 23 | | | |
| Contact closed: the filament command is invalid. | | | | |
| Autocalibration sequence start | 22 | | 11 | |
| Cycle start | 8 | | 30 | |
| Filament on | 20 | | 12 | |
| Gross leak mode selection | 18 | | 31 | |
| Sniffing mode selection | 17 | | 13 | |
| Vent mode selection | 16 | | 32 | |
| Outputs (signals) | | | | |
| Sniffer mode (LDS) | 1 - 2 | | 5 - 24 | |
| Gross leak mode | 3 - 4 | | 4 - 23 | |
| High sensitivity mode | 5 - 6 | | 3 - 22 | |
| Test cycle start | 7 - 9 | | 2 - 21 | |
| Filament on | 10 - 11 | | 9 - 28 | |
| Helium signal > Reject Set point | 12 - 13 | | 1 - 20 | |
| Analog output 0/10 V DC (inlet pressure) | 19 - 15 | 0/10 V | | |
| 0/8 V DC analog output (Helium signal) | 14 - 15 | 0/8 V | 36 - G | 0/10 V |

(2) ASM 182/192 series – ASM 1002

Accessories installation

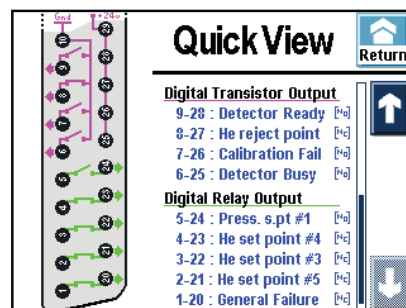
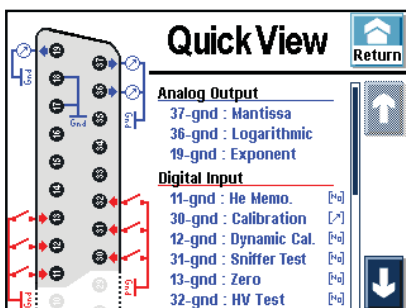

| J15 connector | Detectors with P0323 board ⁽³⁾ | | Detectors with P0419 board | |
|---|---|--|----------------------------|--|
| Electrical ground | 2 - 5 - 8 | | 17 - 18 | |
| Inputs (orders) | | | | |
| Helium signal memorization | 1 | | 11 | |
| Autocalibration | 3 | | 30 | |
| Dynamic calibration coefficient calculation | 4 | | 12 | |
| Control panel locking | 6 | | 31 | |
| Autozero | 9 | | 13 | |
| Sniffing mode | 10 | | | |
| Cycle Start/Stop | 11 | | 32 | |
| 24 V output | 12 | | 35 | |

| J16 connector | Detectors with P0323 board ⁽³⁾ | | Detectors with P0419 board | |
|---|---|--|----------------------------|--|
| Outputs (signals) | | | | |
| Detector ready | 1 | | 9 - 28 | |
| Helium set point No. 1 exceeded signal | 2 | | 8 - 27 | |
| Helium set point No. 2 exceeded signal | 3 | | | |
| Calibration failure | 4 | | 7 - 26 | |
| Detector in cycle or sniffing mode or autocalibration | 5 | | 6 - 25 | |
| Filament 2 selected | 6 | | | |
| Molecular pump at nominal speed | 7 | | | |
| Voltage common A | 8 | | | |
| Helium set point No. 3 exceeded signal | 9 | | 3 - 22 | |

Accessories installation

| J16 connector (ctd) | Detectors with P0323 board ⁽³⁾ | | Detectors with P0419 board | |
|--|---|----|----------------------------|----|
| Outputs (signals) (ctd) | | | | |
| Helium set point No. 4 exceeded signal | 10 | NC | 4 - 23 | NC |
| Voltage common B | 11 | | | |
| Inlet pressure set point No. 1 exceeded signal | 12 | NO | 5 - 24 | NO |

| J17 connector | Detectors with P0323 board ⁽³⁾ | | Detectors with P0419 board | |
|--|---|--------|----------------------------|--------|
| Electrical ground | 9 | | 17 - 18 | |
| Outputs (signals) | | | | |
| Voltage common C | 1 | | | |
| Filament ON | 2 | NC | | |
| Inlet pressure set point No. 2 exceeded signal | 3 | NC | | |
| Sniffer probe clogged | 4 | NO | | |
| General failure detector out of order | 5 | NO | 1 - 20 | NC |
| Helium set point No. 5 exceeded signal | 6 | NO | 2 - 21 | NC |
| Loud speaker | 7 | | 33 | |
| Loud speaker | 8 | | 14 | |
| 0 / 8 V 1 V/decade non-corrected helium signal | 10 | 0/8 V | 36 - G | 0/10 V |
| Mantissa output linear corrected helium signal | 11 | 1/10 V | 37 - G | 1/10 V |
| Exponent output linear corrected helium signal | 12 | 0/10 V | 19 - G | 0/10 V |

(3) ASI 20 MD

Controlling detector

Proposed interfaces

Standard interface

- ① RS 232 (📖 B 301)
- ② 15 pins interface (📖 B 302).

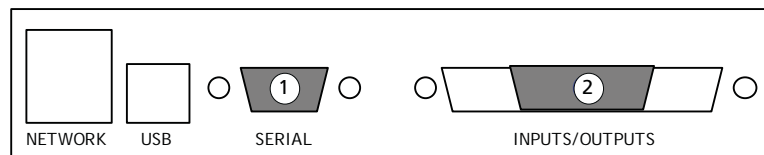

Interface as accessory or option

Each interface is proposed as option and accessory.

As option, it is ordered with the leak detector (one part number for detector + interface) and is placed in the delivered detector, instead of standard interface (except Bluetooth).

As accessory, it could be ordered separately at any time (📖 A 400) and installed by the customer (📖 B 240).

Bluetooth 📖 B 308

37 pins input/output board

- ① RS 232 (📖 B 301)
- ③ 37 pins Input/output interface (📖 B 303)
- ④ USB (📖 B 304)

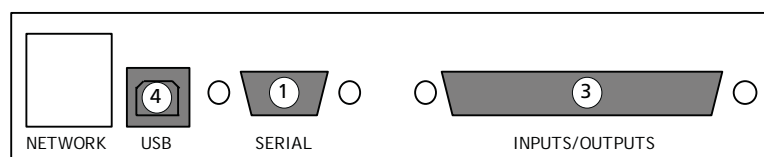

Controlling detector

37 pins input/output board with Wi-Fi

- ① RS 232 (📖 B 301)
- ③ 37 pins Input/output interface (📖 B 303)
- ④ USB (📖 B 304)
- ⑤ Wi-Fi (📖 B 305)

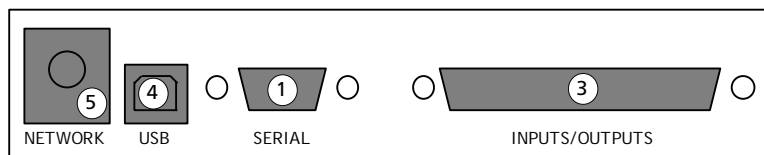

37 pins input/output board with Ethernet

- ① RS 232 (📖 B 301)
- ③ 37 pins Input/output interface (📖 B 303)
- ④ USB (📖 B 304)
- ⑥ Ethernet (📖 B 306)

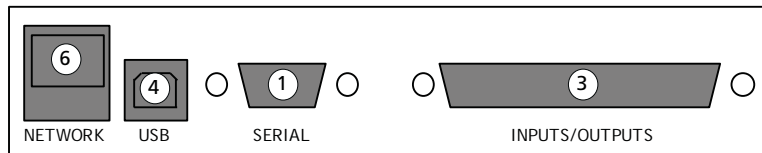

Profibus board

- ② 15 pins interface (📖 B 302)
- ⑦ 9 pins Profibus (📖 B 307)

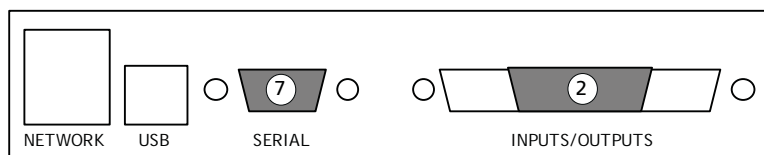

Controlling detector

Interfaces mechanical compatibility

Bluetooth Bluetooth module can be placed on the leak detector whatever is its interface (standard, 37 pins I/O board or Profibus board).

Input/output board (all models) and Profibus board They are placed where the standard interface used to be. Therefore we cannot place both boards in leak detector.

Interfaces software compatibility

User cannot used simultaneously all interfaces: he/she must allocate one interface to each serial link (1 and 2) in Advanced menu (📖 C 406). Only allocated interfaces will be activated.

Note : It is not necessary to remove Bluetooth module from P0411 board on leak detector when it isn't allocated to serial link 2.

You could find in below table possible interfaces for each serial link.

| | Interface | Serial link 1 | Serial link 2 | Type to select |
|----------------------------------|-------------------------|--------------------|--------------------|----------------|
| RS 232 | - | yes | no | Serial |
| Bluetooth ⁽¹⁾ | - | no | yes | Bluetooth |
| 37 pins I/O board ⁽¹⁾ | USB ⁽³⁾ | yes ⁽³⁾ | yes ⁽³⁾ | USB |
| | Wi-Fi ⁽²⁾ | no | yes | Network |
| | Ethernet ⁽²⁾ | no | yes | Network |
| Profibus board ⁽⁴⁾ | - | yes | no | Serial |

(1) Option or accessory

(2) Available according to I/O board model

(3) Cannot be allocated simultaneously to both serial links

(4) Option or accessory, ASI 30 only

Controlling detector

**Bluetooth
input/output board
Profibus board
installation**



Data export

RS 232, USB, Wi-Fi and Ethernet allows connecting PC to leak detector in order to export 3 predefined test tickets:

| Tests ticket | Example | Export |
|---|----------|---|
| Calibration with an internal/external calibrated leak | A | Automatic export after an internal calibration with an internal/external leak |
| Calibration checking with an internal leak | B | Automatic export after a calibration checking with an internal leak |
| Test | C | Automatic export at the end of the test |

Calibration ticket with an internal calibrated leak

A

```

DATE:Jan/08/2007 TIME:01:34:41
ASM310 CALIBRATION gas:           He
unit:                             mbar.l/sec

CALIBRATED LEAK PARAMETERS:
location:                          internal/external
value:                             1.5E-07
unit:                             mbar.l/sec
calibration year:                  2005
loss per year (%):                 06.00
calibration temperature (C):       20
temperature coefficient (%/C):     3.00
TARGET PARAMETERS:
current internal temperature (C):   32
target value:                      1.9E-07
ELECTRONIC ZERO:
done:                               yes
PEAK ADJUSTMENT :
dac_ref.=1162
vacc_ref.=141.8
dac_peak.=1179
vacc_peak.=141.8                  yes
SIGNAL RECORDS (no calibrated):
global:                            3.5E-07
background:                        1.1E-10
CALIBRATION INFORMATIONS:
total time(sec):                   75
result:                            COMPLETED

CURRENT ASM310 CALIBRATION:
DATE:Jan/08/2007 TIME:01:34:41
Fil:1 Ie=0.6 Vac=140.6
Coef_cal:00.54
    
```

Controlling detector

Calibration checking ticket with an internal calibrated leak

B

CALIBRATION INFORMATIONS:
 DATE|Jan/08/2007 TIME|01:37:20
 current internal temperature(C)| 32
 current coef.sens| 00.54
 global rate| 1.91E-07
 background rate| 6.39E-11
 calibrated leak-rate| 1.191E-07
 target value| 1.89E-07
 percent allowance (+/-)| 15
 RESULT(%): 1

Test ticket

C

| DATE:Jan/08/2007 | HOUR | CASE | PRESSURE | LEAKRATE |
|------------------|------|-------|----------|----------|
| 00:28:26 | | start | 3.8E+01 | 3.4E-11 |
| 00:28:55 | | GL | 1.2E-02 | ----- |
| 00:29:40 | | NR | 6.3E-05 | ----- |
| 00:29:45 | | stop | 5.8E-05 | 1.1E-05 |
| | | | NR | |

Leak value

| DATE:Jan/08/2007 | HOUR | CASE | PRESSURE | LEAKRATE |
|------------------|------|-------|----------|----------|
| 01:02:31 | | start | 6.5E+01 | 4.8E-11 |
| 01:02:32 | | GL | 4.6E+01 | ----- |
| 01:02:33 | | NR | 5.9E-02 | ----- |
| 01:02:36 | | stop | 9.9E-05 | 1.3E-05 |
| | | NR | | FAIL |

Leak value

Test result if Memo function activated
 (C 406)

PC/leak detector connecting cable (serial link)

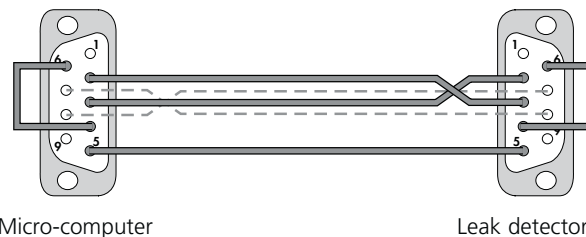

Controlling detector

Connector

| Pin # | Function | Communication protocol | |
|-------|----------------|------------------------|--------------|
| 1 | not used | Mode | Asynchronous |
| 2 | Rx | Bauds | 9600 |
| 3 | Tx | Bits | 8 |
| 4 | not used | Parity | None |
| 5 | ground | Stop bit | 1 |
| 6 | not used | Parity control | None |
| 7 | not used | | |
| 8 | not used | | |
| 9 | + 5 V ; 500 mA | | |

Export procedure « ADX Dialog » free software (or other similar terminal software) must be before loaded in PC:  **G 800**.

Connect the leak detector to PC via RS 232 link, USB, Wi-Fi or Ethernet.

Launch « ADX Dialog » software.

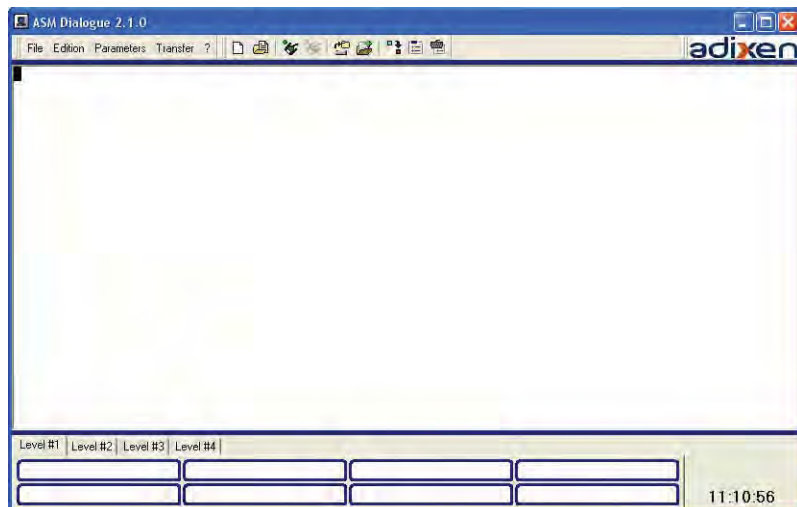

Controlling detector

Set communication parameters.

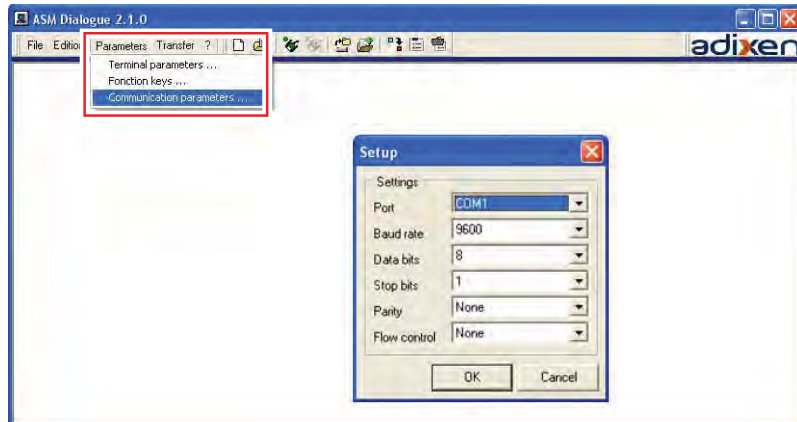

Open communication port.

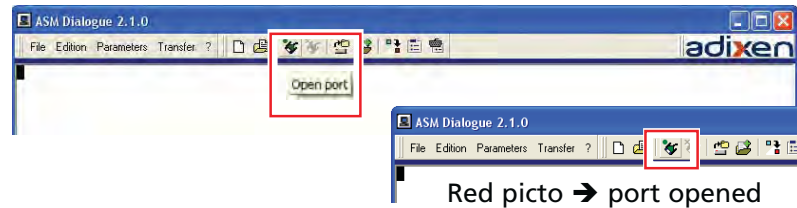

Create a .txt file in which all predefined test tickets, automatically created, will be exported.

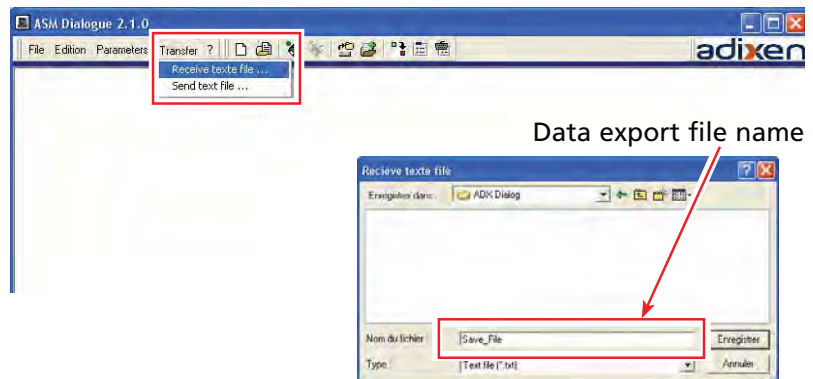

From this moment, all test tickets created and displayed in « ADX Dialog » will be exported in the created export file.

Controlling detector

Example: « ADX Dialog » window

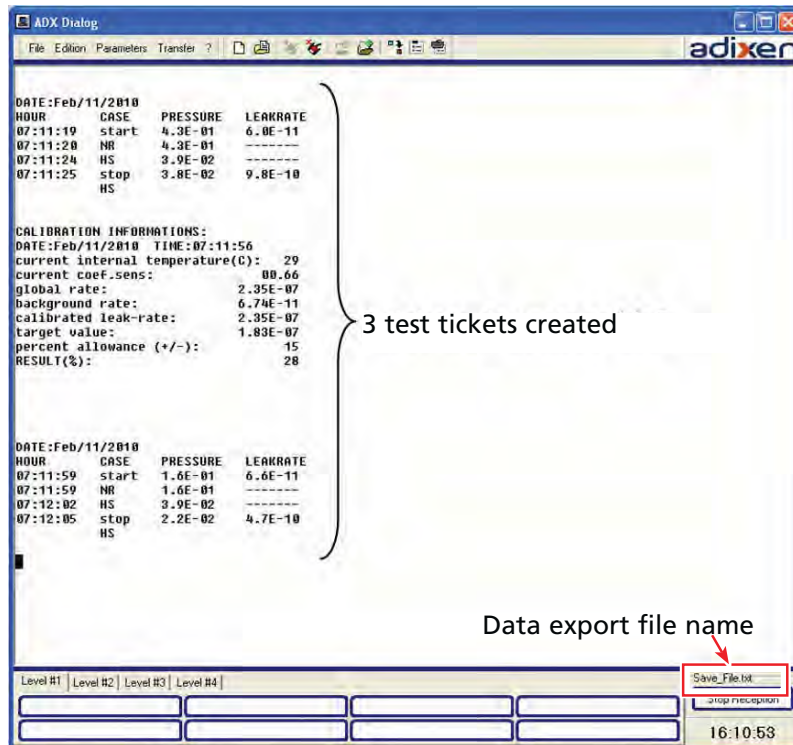

Stop data export (test tickets created).



Controlling detector

Example: « Save_File.txt » file created.

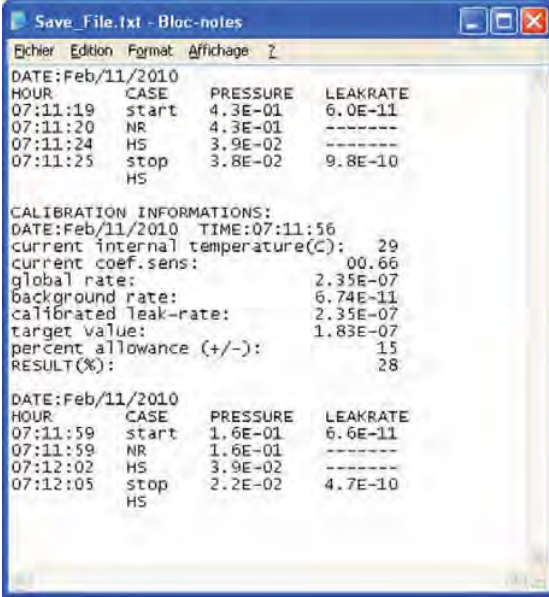

```
Save_File.txt - Bloc-notes
-----
Fichier Edition Format Affichage ?
DATE:Feb/11/2010
  HOUR   CASE   PRESSURE   LEAKRATE
07:11:19 start  4.3E-01    6.0E-11
07:11:20 NR    4.3E-01    -----
07:11:24 HS    3.9E-02    -----
07:11:25 stop  3.8E-02    9.8E-10
          HS

CALIBRATION INFORMATIONS:
DATE:Feb/11/2010 TIME:07:11:56
current internal temperature(C): 29
current coef.sens:                00.66
global rate:                       2.35E-07
background rate:                   6.74E-11
calibrated leak-rate:              2.35E-07
target value:                      1.83E-07
percent allowance (+/-):           15
RESULT(%):                         28

DATE:Feb/11/2010
  HOUR   CASE   PRESSURE   LEAKRATE
07:11:59 start  1.6E-01    6.6E-11
07:11:59 NR    1.6E-01    -----
07:12:02 HS    3.9E-02    -----
07:12:05 stop  2.2E-02    4.7E-10
          HS
```

RS 232

Purpose The RS 232 interface allows to control the leak detector with a PC compatible computer.

Connection Refer to  **B 400**.

The Sub D 9 pin femelle connector is at customer's charge.



- Use**
- It is necessary to allocate RS 232 to serial link 1 in the control panel advanced menu ( **C 406**) to activate it.
 - Refer to the RS 232 specific operating manual supplied with the leak detector operating manual.

15 pin Interface

Purpose The 15 pin Input/Output interface allows to control the leak detector with a programmable logic controller or any other external control device.

It also allows to get back a 0 - 10 V signal (1 V/decade) corresponding to the leak flow measurement.

Connection Refer to  **B 400**.

The 15 pin male connector and its cover are supplied with the leak detector.

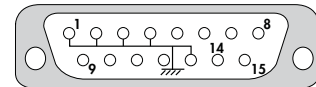

CAUTION

It is recommended to use a shielded cable which is grounded on the connector cover.

Use

| | | | |
|------------|---------|----|--------------------------------|
| Inputs | Digital | 14 | Cycle start |
| | Analog | 5 | Not activated |
| Outputs | Digital | 6 | Selected test mode reached |
| | | 7 | Reject point threshold crossed |
| | Analog | 9 | Mantissa (0/10 V)* |
| | | 10 | He signal (logarithmic) (*) |
| | | 11 | Not activated |
| | | 12 | Exponent (0/10 V) |
| Ground | | | 1 - 2 - 3 - 4 - 13 |
| Headphones | | 8 | Headphones + ⁽¹⁾ |
| | | 15 | Headphones - ⁽¹⁾ |

(*) By default ; Adjustable by the user.

(1) To activate audio/headphones output, it is necessary to send "=HPD" RS 232 command to the leak detector : this command deactivates the loudspeaker.

To deactivate audio/headphones output, it is necessary to send "=HPE" RS 232 command to the leak detector : this command activates again the loudspeaker.

15 pin Interface

- Analog Output**
- 2 adjustable analog outputs. For each, user can set its allocation and, if necessary, the start decade (scale start). There is also 1 fixed output (19-ground) for the exponent.

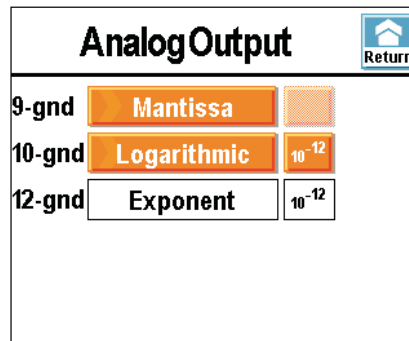

Possible values for each output:

| Value | Function |
|----------------|---|
| Mantissa | 1/10 V (*) |
| Exponent | 0/10 V – Low decade to set (*) |
| Logarithmic | 0/10 V - Low decade to set (*) |
| Inlet pressure | If a pressure measurement gauge is installed in the customer installation (at the customer's charge) (*) 2,5 V/8,5 V (10 ⁻³ to 10 ⁺³ mbar) |
| He compound | 0/10 V (compound exponent, mantissa) |

(*) Graphs and formulas in appendix: G 300

After modification, we advise to save all inputs/outputs set.

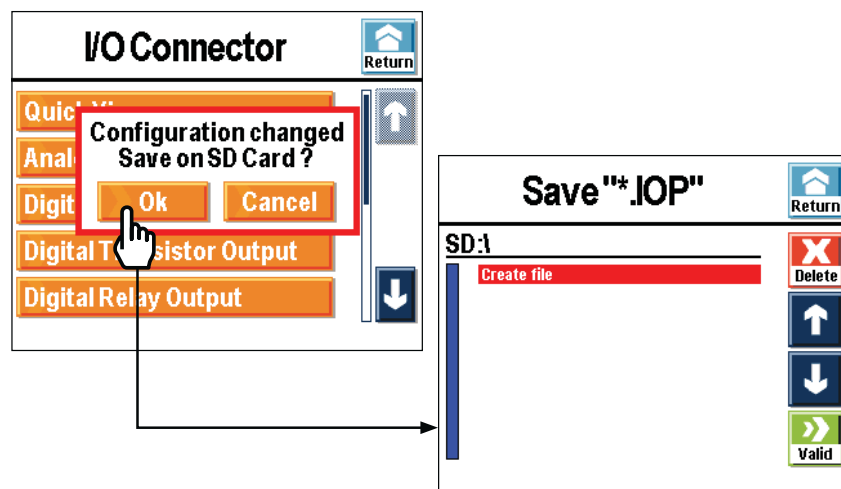

37 pin Input/Output interface

Purpose 37 pin Input/Output interface (in option or accessory) allows controlling:

- leak detector with programmable logical controller or any other external control device.
- customization (valves, ...) with leak detector.

While 15 pin interface offers only 1 input and 5 outputs specified, 37 pin I/O interface offers 6 inputs and 12 outputs, each adjustable by the user (choice of 13 functions for inputs and 25 for outputs).

37 pin I/O interface can be control separately of the leak detector.

HARDWARE

CAUTION

Leak detector connection to customer installation and 37 pin I/O interface setting must be done by authorized personnel.

Connection Refer to  B 400.

37 pin male connector and its cover are delivered with interface.



| | | |
|----------------|------------|---|
| Inputs | Digital | 11 – 12 – 13 – 30 – 31 -32 |
| | Accessory | 34 - 35 - 15 - 16: saved |
| Outputs | Digital | 1 to 9 – 20 to 28 |
| | Analogical | 19 – 36 – 37 (ground: 17 – 18) |
| | Others | 29: + 24 V internal or external ⁽¹⁾ 10: internal or external ground ⁽¹⁾ 33 - 14 : headphones (8 Ω) ⁽²⁾ |

(1) According to SW1 switch configuration

(2) To activate audio/headphone output, it is necessary to send "=HPD" RS 232 command to the leak detector : this command deactivates loudspeaker.
To deactivate audio/headphone output, it is necessary to send "=HPE" RS 232 command to the leak detector : this command activates again the loudspeaker.

37 pin Input/Output interface

Input/output surveillance

P0419 interface board allows controlling input/output. A led is dedicated at each input/output.

Board localization  F 400

Board access  E 110

Leds localization

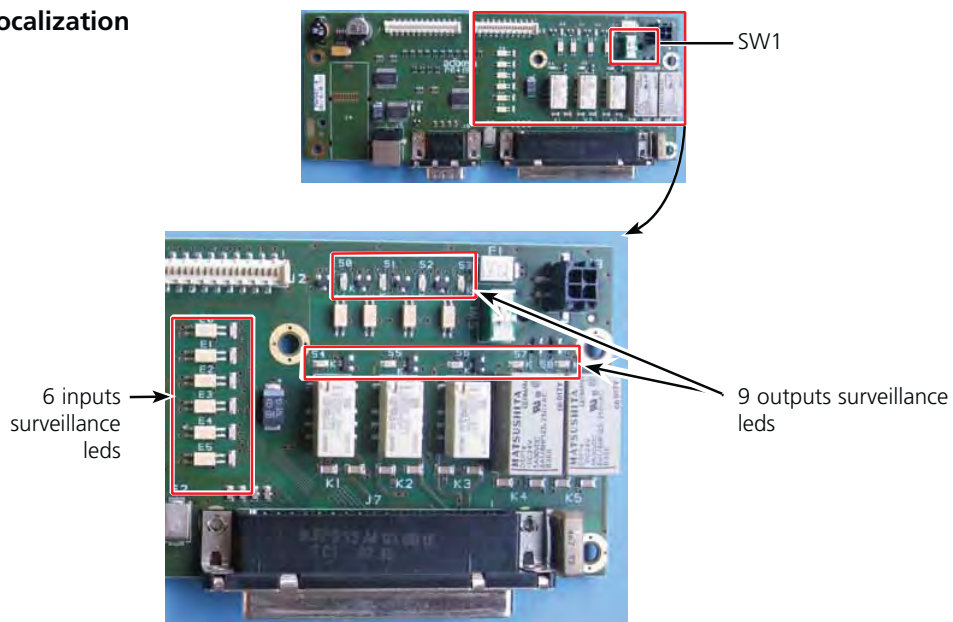

Internal 24 V or external 24 V power supply ($\pm 10\%$)

Set SW1 switch according to power supply type.

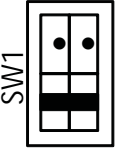
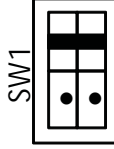
| Internal power supply | External power supply |
|---|---|
|  |  |

OFF → external 24 V + external ground

ON → internal 24 V + internal ground

By default, electronic unit is delivered with SW1 set on OFF.

37 pin Input/Output interface

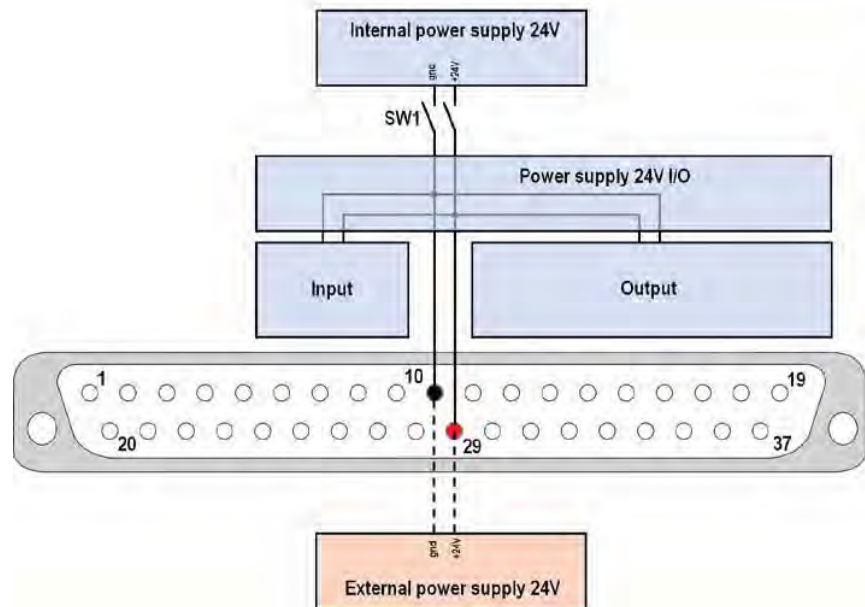

Inputs (Orders) 6 optocoupled digital inputs allow running leak detector.

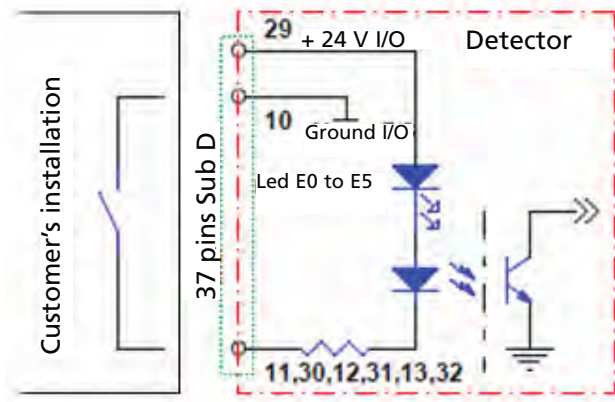

Example « 11-gnd » input is attributed to « HV Test », the hard vacuum test start function.













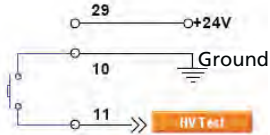

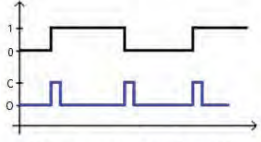

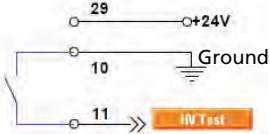
Digital Input Return

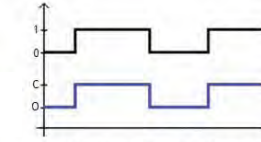
11-gnd HV Test ⏮ ⏭

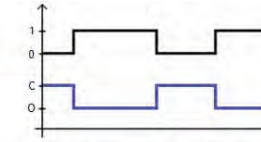
37 pin Input/Output interface

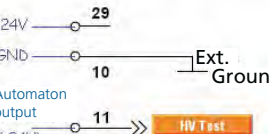
Note Examples given below show 3 typical uses of digital inputs: we advise to set the 24 V and mode as indicated in the example (example: push button with internal 24 V and impulsion mode).

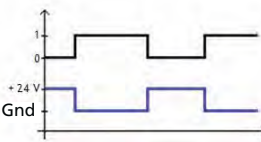
As 24 V and mode are adjustable, you can however set them differently.

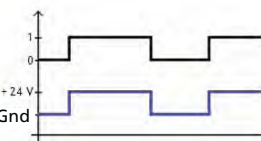
| Type | 24 V | Diagram | Mode | Logical state |
|--|---|---|---|---|
| Push button  | Internal  |  |  | Test Push button  <p>C: closed - O: opened</p> |
| Switch  | Internal  |  |  | Test Switch  <p>C: closed - O: opened</p> |
| | | |  | Test Switch  <p>C: closed - O: opened</p> |
| External control device  | External  |  |  | Test External control device  <p>+24 V Gnd</p> |
| | | |  | Test External control device  <p>+24 V Gnd</p> |

Digital outputs (signals)

3 digital outputs types:

- Digital output direct/alternating current: DS-P relay,
- Digital output direct current: TX relay,
- Digital output direct current: MOFSET transistor.

37 pin Input/Output interface

DS-P relay Digital relay output

- Quantity: 2 → 1-20 ; 2-21
- Functions: according to user setting
- Dry contact type
- Direct current:
 - 60 V DC – 2.5 A max
 - 30 V DC – 5 A max
- Alternating current: 250 V AC - 5 A max
- Diagram:

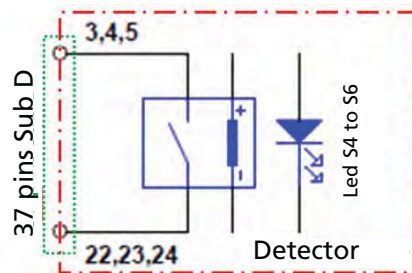
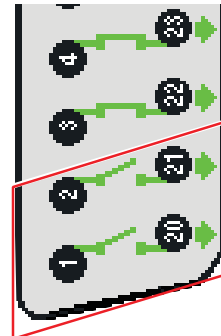

■ We recommend using a maximum of 60 V AC even if the wiring is for 250 V AC.

TX relay Digital relay output

- Quantity: 3 → 3-22 ; 4-23 ; 5-24
- Functions: according to user setting
- Dry contact type
- Direct current:
 - 60 V DC – 1 A max
 - 30 V DC – 2 A max
- Diagram:

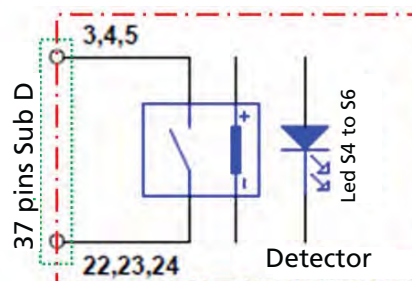
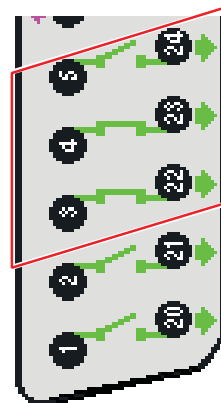

Example « 5-24 » output is attributed to « He reject point », the He reject point function.





Digital Relay Output



5-24 He reject point NO

37 pin Input/Output interface

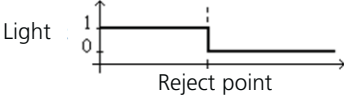
Note Example given below shows a typical use of digital outputs

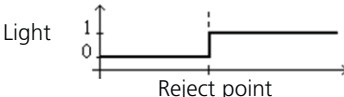
| Type | 24 V | Diagram | Mode | Logical state |
|--|----------------------|---|---|--|
| Light  | Internal or External |  |  | Light  |
| | | |  | Light  |

MOSFET transistor Digital Transistor output

- Quantity: 4 → 6-25 ; 7-26 ; 8-27 ; 9-28
- Functions: according to user setting
- Open collector type
- Direct current: 30 V DC – 1 A max – 30 W
- Diagram:

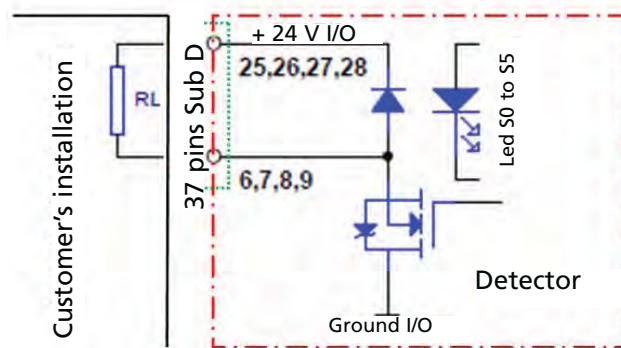
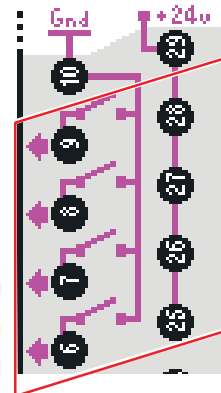

External 24 V ± 10 % power supply is essential for having the advantage of the optocoupled gate (atmosphere with interferences) and/or supplying transistor Mosfet outputs 25 to 28. In this case, SW1 must be set on OFF position to avoid any detector deterioration.

For an occasional use, it is possible to use leak detector internal 24 V if global power on outputs 25 to 28 is less than 3 A.



- These outputs could be used to control electromagnetic valve (24 V DC – 24 W max).



37 pin Input/Output interface

Example « 9-28 » output is attributed to « Press. s.pt #1 », the pressure set point # 1 function.

Digital Transistor Outp.. 

9-28 **Press.s.pt #1** **NO**

Note Example given below shows a typical use of digital outputs

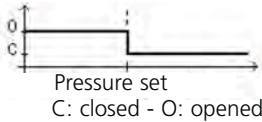
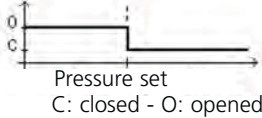
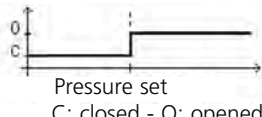
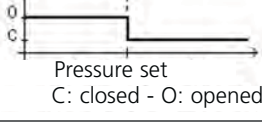
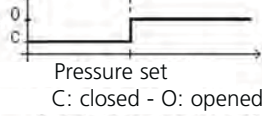
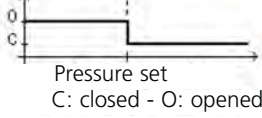
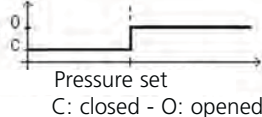
| Type | 24 V | Diagram | Mode | Logical state |
|--|---|---|-----------|--|
| Electrovalve  | Internal  |  | NO | Electrovalve  C: closed - O: opened |
| | | | NC | Electrovalve  C: closed - O: opened |
| | External  |  | NO | Electrovalve  C: closed - O: opened |
| | | | NC | Electrovalve  C: closed - O: opened |

SOFTWARE

Input/output screen copies are given for example. They can vary according to user setting.

Parameters access

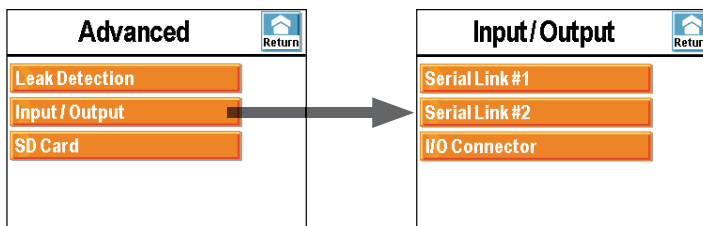

37 pin Input/Output interface

Before use, user must choose the input/output of his/her choice.

Serial link 1 Refer to  C 406.
Serial link 2

I/O connector

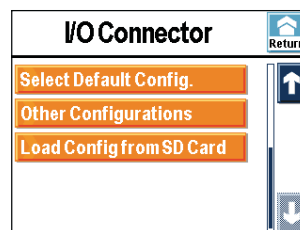
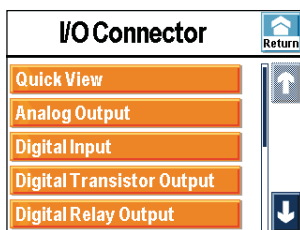

- Saving**
- For any modification in a "I/O connector" sub-menu, a complete saving of all set I/O parameters are proposed.

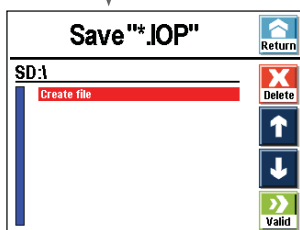
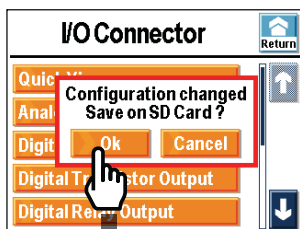

The saving file will be a ".IOP" file.

37 pin Input/Output interface

Quick View These screens can show for each output:

- its connection pins,
- its allocation (function, parameter, order),
- its state (allocation and contact),
- its activation mode.

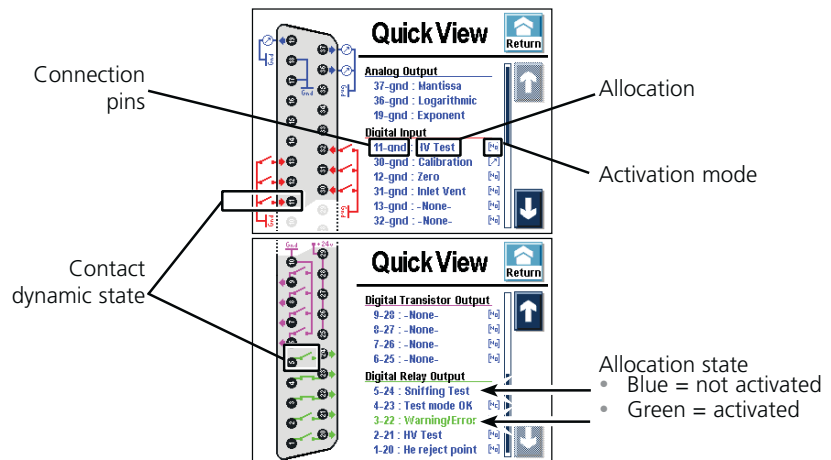

Analog Output ■ 2 adjustable analog outputs. For each, user can set its allocation and, if necessary, the start decade (scale start). There is also 1 fixed output (19 – ground).

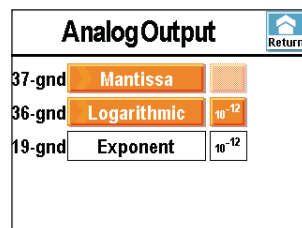

Possible values for each output:

| Value | Function |
|----------------|--|
| Mantissa | 1/10 V (*) |
| Exponent | 0/10 V – Low decade to set (*) |
| Logarithmic | 0/10 V - Low decade to set (*) |
| Inlet pressure | If a pressure measurement gauge is installed in the customer installation (at the customer's charge) (*) 2,5 V/8,5 V (10^{-3} to 10^{+3} mbar) |
| He compound | 0/10 V (compound exponent, mantissa) |

(*) Graphs and formulas in appendix: G 300

37 pin Input/Output interface

- Digital Input** ■ 6 adjustable digital inputs. For each, the user can set its allocation and its activation mode.

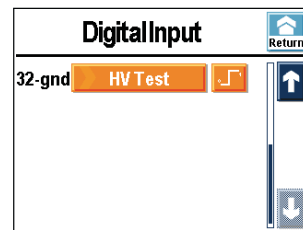
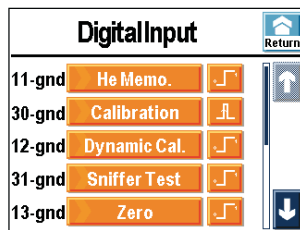

Activation on rising edge
Deactivation on falling edge





Activation on falling edge
Deactivation on rising edge



Activation/Deactivation by impulse



- Activation on rising edge  is advised in general way.
- Activation on falling edge  is generally used for function which must be activated on positive security.
- Activation by impulse  is generally used for cycle start/stop by user, push button or cycle pedal.

37 pin Input/Output interface

Possible values for each input:

| Value | Function |
|--------------|--|
| None | |
| HV test | Start/Stop a test in hard vacuum mode |
| Calibration | Start an autocalibration |
| Zero | Activate/Deactivate Zero function |
| He Memo | Activate/Deactivate Memo function |
| Dynamic cal. | Start a dynamic calibration ⁽²⁾ |
| Sniffer test | Start/Stop a test in sniffing mode |
| Filament | Force stop/start filament |
| GL mode | Force leak detector ⁽¹⁾ in Gross Leak test mode |
| NR mode | Force leak detector ⁽¹⁾ in Normal test mode |
| HS mode | Force leak detector ⁽¹⁾ in High Sensitivity test mode |
| Inlet vent | Opening/closing of the inlet vent valve ⁽¹⁾ |
| Rec. Graph | Start/stop data recording |
| Save Graph | Save recorded data on a SD card |

(1) ASI 30 not concerned

(2) Only ASI 30 concerned

Digital Output

■ 4 adjustable digital transistor outputs.



■ 5 adjustable digital relay outputs, dry contact type.



| Digital Transistor Outp. | | |  |
|--------------------------|------------------|----|---|
| 9-28 : | Detector Ready | NO | |
| 8-27 : | He reject point | NC | |
| 7-26 : | Calibration Fail | NO | |
| 6-25 : | Detector Busy | NO | |

| Digital Relay Output | | |  |
|----------------------|-----------------|----|---|
| 5-24 : | Press. s.pt #1 | NO | |
| 4-23 : | He set point #4 | NC | |
| 3-22 : | He set point #3 | NC | |
| 2-21 : | He set point #5 | NC | |
| 1-20 : | General Failure | NC | |

37 pin Input/Output interface



For each, user can set its allocation and its activation mode.

  Normally Open
Unused, output not switched

  Normally Close
Unused, output switched

Possible values for each output:

C: closed - O: opened

| Value | Function | Setting | |
|------------------|--|---|---|
| | |  |  |
| | | Active state ↓ | Active state ↓ |
| None | | | |
| He reject point | Detector reject set point ⁽¹⁾ | C | O |
| He set point # 2 | Leak # 2 set point value ⁽¹⁾ | C | O |
| He set point # 3 | Leak # 3 set point value ⁽¹⁾ | C | O |
| He set point # 4 | Leak # 4 set point value ⁽¹⁾ | C | O |
| He set point # 5 | Leak # 5 set point value ⁽¹⁾ | C | O |
| Warning/Error | Warning/error message to consult | C | O |
| HV test | Detector in hard vacuum test mode | C | O |
| Sniffing test | Detector in sniffing test mode | C | O |
| Detector ready | Detector ready to perform a test | C | O |
| Calibration fail | Calibration failure | C | O |
| Detector busy | Detector state is start, test or calibration | C | O |
| Filament # 2 on | Filament # 2 selected | C | O |
| HV pump synch | Hard vacuum pump synchronized | C | O |
| Filament on | Selected filament ON | C | O |
| Snif. Clogged | Sniffer probe clogged | C | O |

(1) Helium leak measured > leak set point value set

37 pin Input/Output interface

C: closed - O: opened

| Value | Function | Setting | |
|-----------------|---|--------------|--------------|
| | | NO | NC |
| | | Active state | Active state |
| Press s. pt # 1 | Pressure # 1 set point value ⁽²⁾⁽³⁾ | O | C |
| Press s. pt # 2 | Pressure # 2 set point value ⁽²⁾⁽³⁾ | O | C |
| HV Cor | High vacuum signal corrected | C | O |
| Maint. Required | Maintenance required | C | O |
| Sniffer valve | Sniffing valve control | C | O |
| GL test | Detector in Gross Leak test mode ⁽⁴⁾ | C | O |
| N test | Detector in Normal test mode ⁽⁴⁾ | C | O |
| HS test | Detector in High Sensitivity test mode ⁽⁴⁾ | C | O |
| General failure | Critical failure on the detector | C | O |
| Test mode ok | Target test mode reached ⁽⁴⁾ | C | O |

(2) Measured pressure ≤ Pressure set point value set

(3) ASI 30 not concerned unless a pressure gauge is installed in customer's installation (at the customer's charge).

(4) ASI 30 not concerned

Select Default Config



It is the input/output configuration by default at the detector delivery (C 500).

It is dedicated to one model of leak detector.

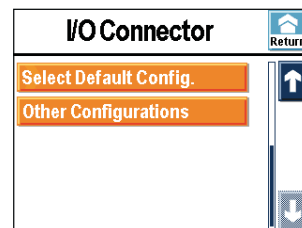

37 pin Input/Output interface

Other configurations 3 predefined configurations are available.

Each input/output can be reset according to needs.

More information about configurations: refer to (E 261).

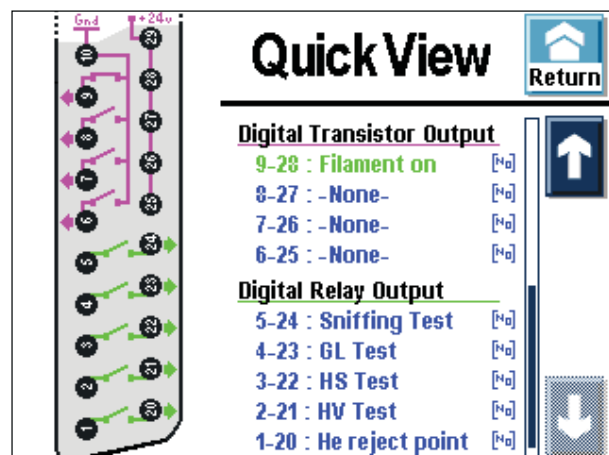
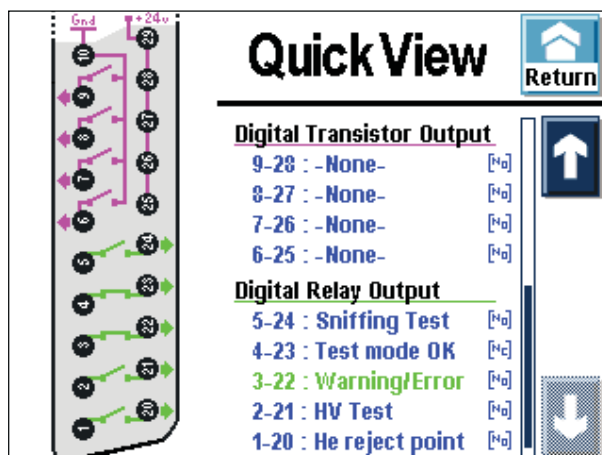
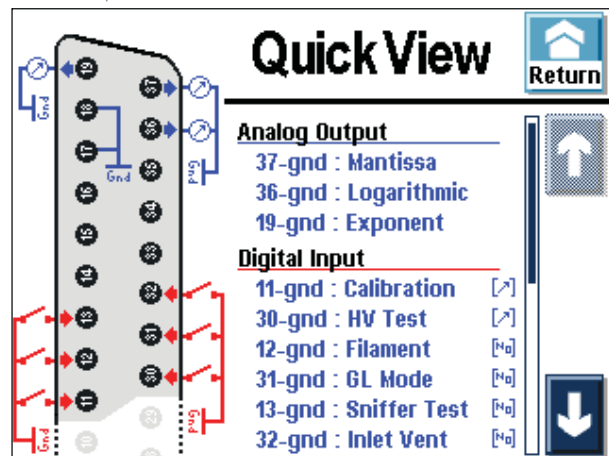
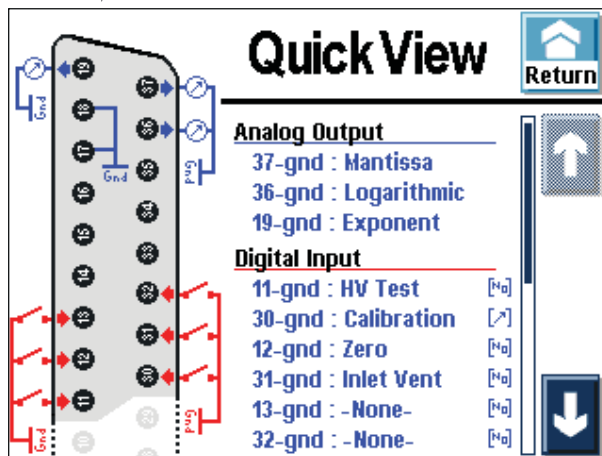
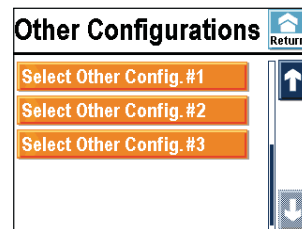

37 pin Input/Output interface

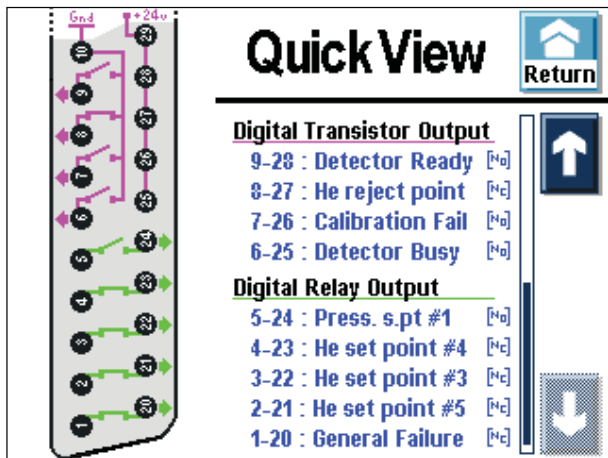
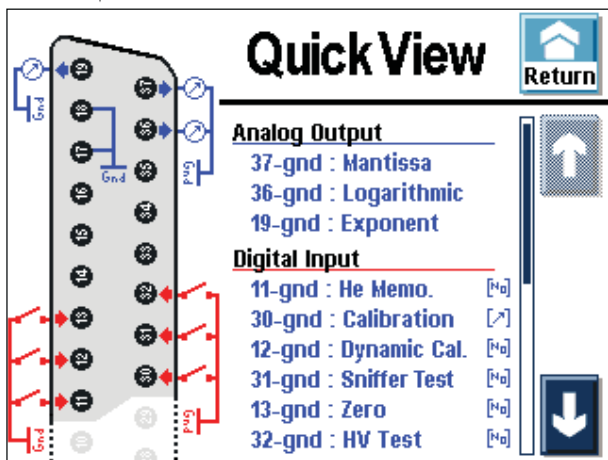

USB

Purpose USB allows connecting leak detector to PC.

Connection Refer to  **B 400**.

Male USB plug placed on detector.

USB cable is not delivered with interface: customer supplies.



Compatibility with the other interfaces

- If leak detector is also equipped with Bluetooth module, user can select simultaneously Bluetooth (serial link 2) and USB (serial link 1).
- It is not necessary to remove Bluetooth module when USB is used.

Preliminary conditions

- It is necessary to allocate USB to serial link 1 or 2 in control panel Advanced menu ( **C 406**) to active it: set « USB ».
- To use USB, user must first load on his/her PC the USB driver delivered in the operating manual CD Rom.
After the driver is loaded and set, user has a virtual RS 232 serial link allowing controlling the leak detector from a PC.

USB is very useful for PC without RS 232 link.

RS 232: refer to  **B 301**.

USB setting

Displays below are given as examples (Windows XP). They can be changed according to PC system.

Electronic module/PC link configuration

Connect an **USB cable type A-B (imperative) between USB port and your PC.**

USB module configuration From cable connection, module is detected.

USB



Software to load is delivered in the operating manual CDRom.

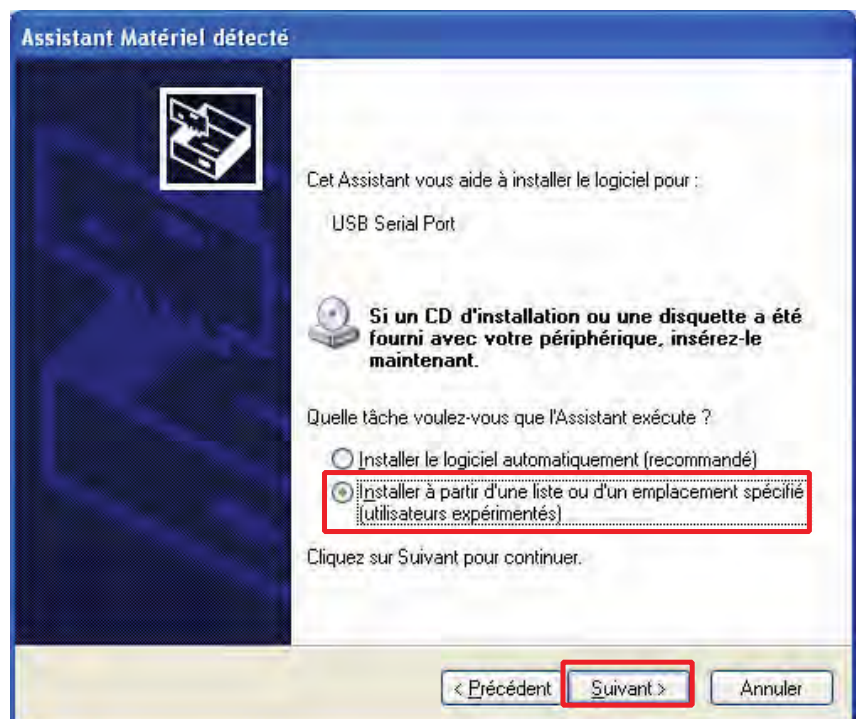

USB

Insert operating manual CDRom in your CD/DVD reader.

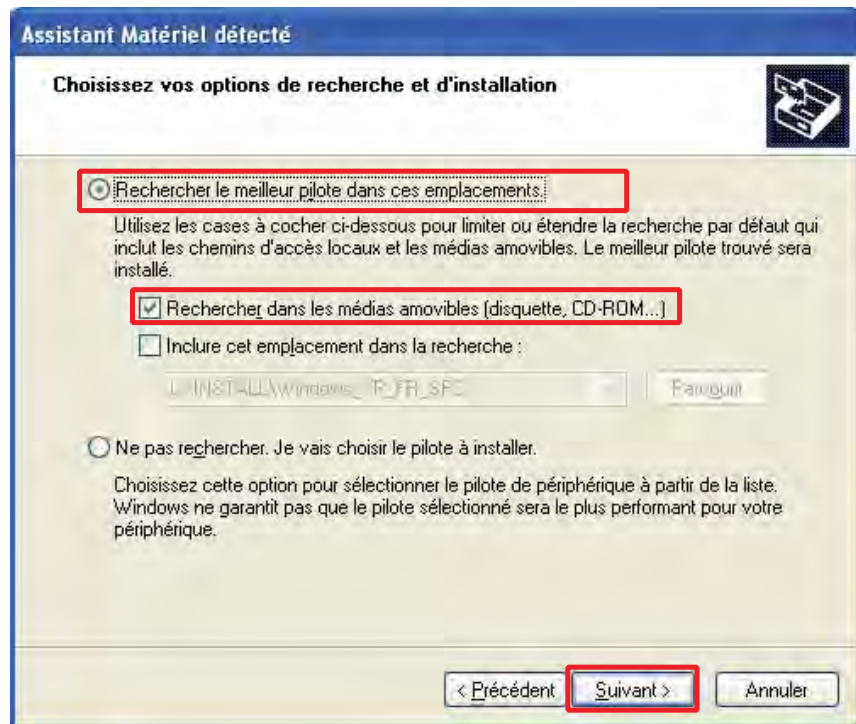

As soon as software is found in CDRom, loading starts automatically.



USB

USB port is created.



To know that USB port is allocated, you must consult your device manager.

Control panel → System
→ Hardware → Device
manager → Ports (COM
and LPT)

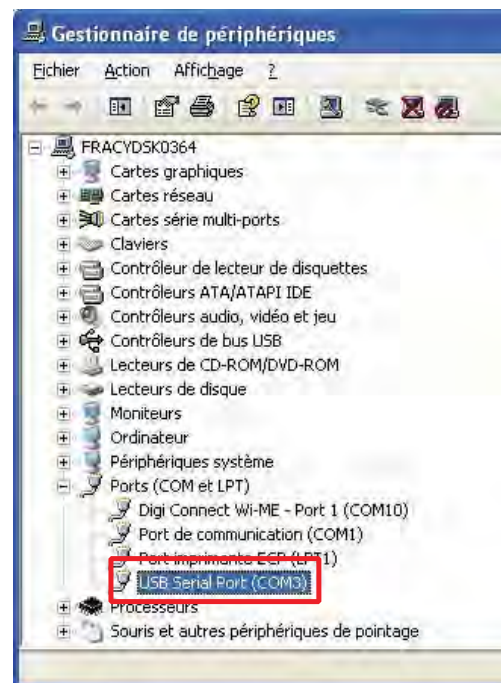

In our example, USB port is
allocated to COM 3.

Port allocation (COM) is completely controlled by PC. If you disconnect and connect again USB cable, it is possible that allocated port has been changed: check port (COM) allocated after each cable connection.

To uninstall USB port created, select USB module allocated to the PC serial port, then "Uninstall".

Wi-Fi

Purpose Refer to  **A 300**.

Network Most of time, inside, we allow a range of 25 m in a dense environment (with big obstacles) and 60 m if there are only thin partitions to cross.

Connection Refer to  **B 400**.

Compatibility with the other interfaces

- If leak detector is also equipped with Bluetooth module, user cannot select simultaneously Bluetooth and Wi-Fi.
- It is not necessary to remove Bluetooth module when Wi-Fi is used.

Preliminary conditions

- It is necessary to allocate Wi-Fi to serial link 2 in control panel Advanced menu ( **C 406**) to active it: set « Network ».
- To use Wi-Fi, user must first load on his/her the PC Wi-Fi driver delivered in the operating manual CDRom.

Use with a detector After driver is loaded and set, user has a virtual RS 232 serial link allowing controlling the leak detector from a PC.
It is possible to talk in direct order mode Wi-Fi using TELNET protocol.

Use with a PDA Wi-Fi use requires ASM Pocket application installation ( **G 800**) in PDA. ASM Pocket and its use instructions are available free on www.adixen.com website.
PDA use area is from 10 to 30 meters (free field).

Equipment The PDA is supplied by the customer. The user must configure the PDA to be used with the leak detector.
Minimal configuration of PDA to use:

- Windows Mobile 5 mini.

Wi-Fi setting Displays below are given as examples (Windows XP). They can be changed according to PC system.

Wi-Fi

Electronic module/PC link configuration

Create a Wi-Fi network: parameters → wireless network connection properties → wireless networks → properties

Select « Wireless network » tab.

Select Windows to configure your wireless network settings.

Add a favorite network.

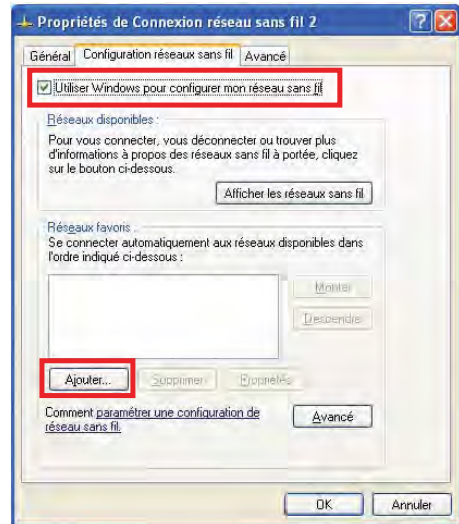

Name the network « Connect ».

Deactivate Network authentication.

Select computer-to-computer network.

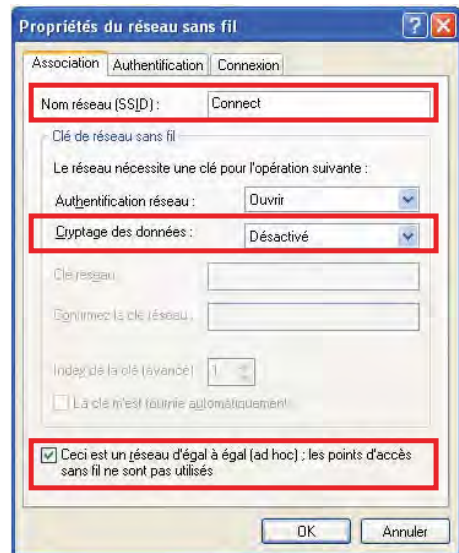

Wi-Fi

Select « Connection » tab.

Connect automatically when this network is in range.

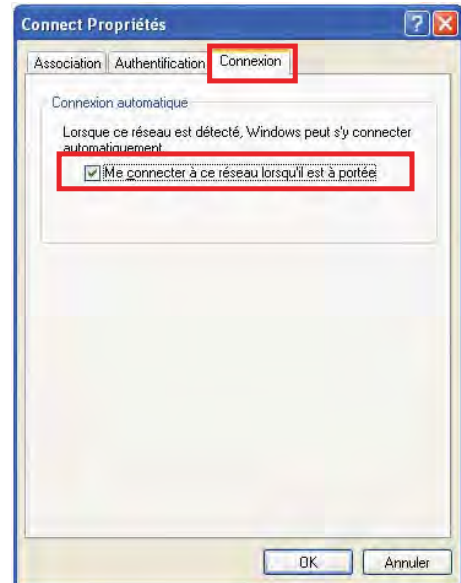

Select « Association » tab.

Validate (OK) « Connect » network creation.

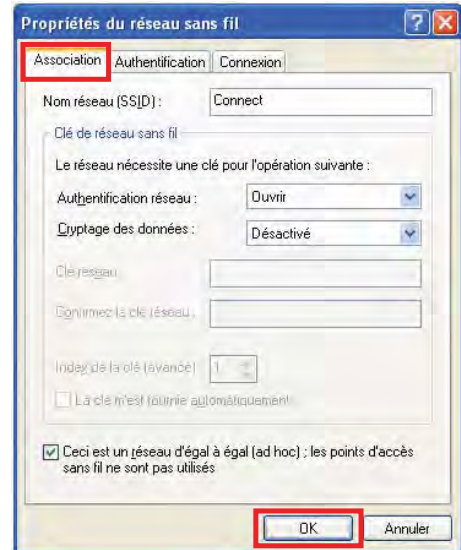

Validate information message displayed.

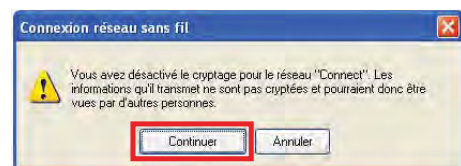

Wi-Fi

Select « Connect » network created.

Validate (OK) network connection.

Connection between electronic module and PC is automatic :

- orange led flashing on the module during connection.
- orange led ON permanently on the module when all is ok.

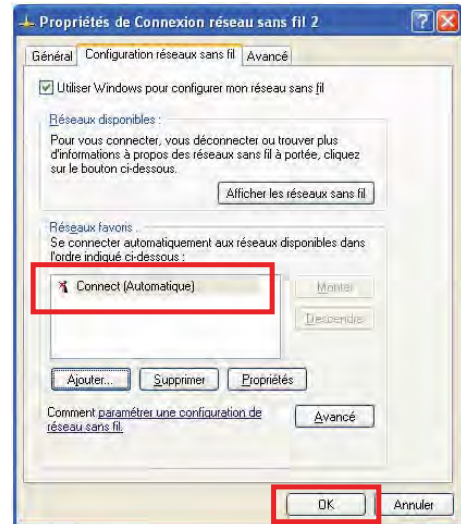

Wi-Fi module configuration

① **Load driver**

« Digi Device Discovery.exe » driver is delivered in the operating manual CDRom of your product.

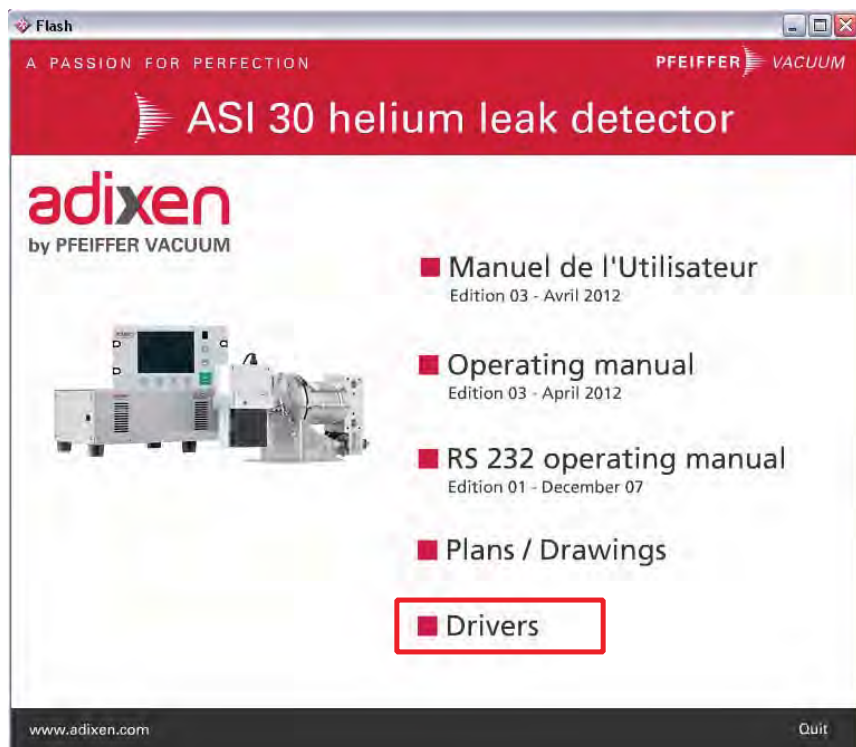

Wi-Fi

② Change Wi-Fi module IP address

Launch «  Digi Device Discovery » software.

Wi-Fi module is detected.

If not, launch again detection: press on « Refresh view ».



Note: Wi-Fi module appears in menus with « Digi Connect WI-ME » name.

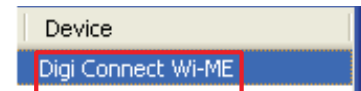

■ If the module IP address detected is correct, symbol  appears.

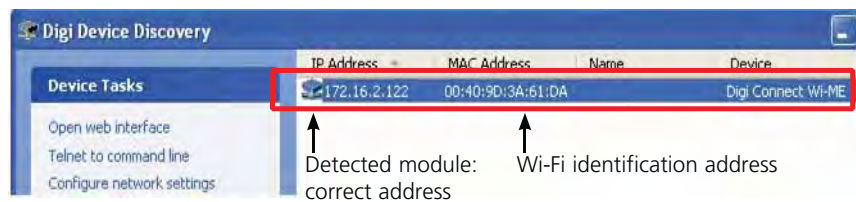

Note : MAC address is unique and peculiar to each Wi-Fi module. It is indicated on the module and/or identification label stuck on the electronic module ( **B 112**). To select a detector among several detectors, select MAC address of the wanted detector.

Wi-Fi

- If detected module IP address is not correct,  appears.

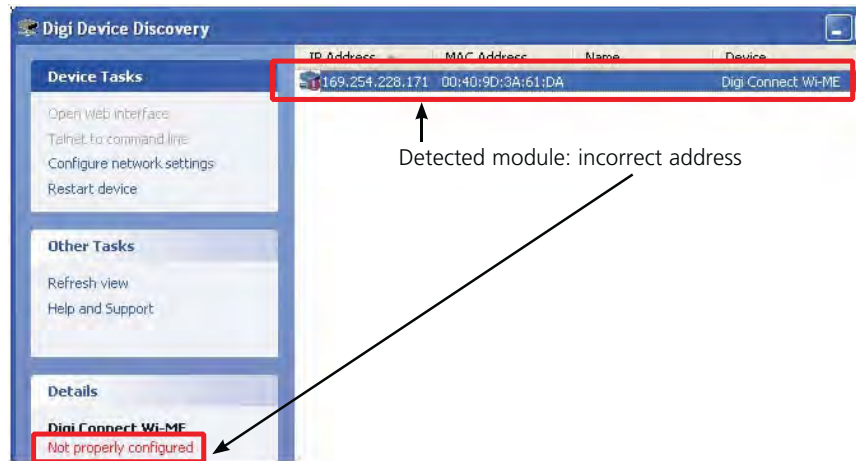

Change module IP address to be in the same sub network as your PC.



Save new addresses.

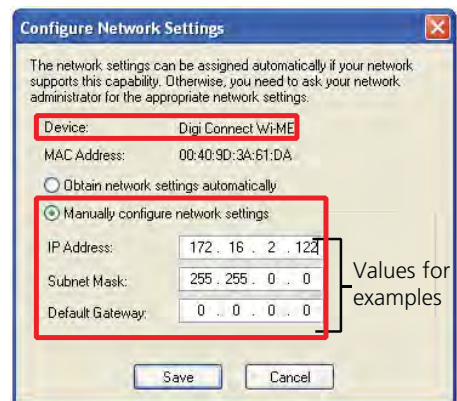

Contact your Network administrator for IP addresses to set.

Wi-Fi

To finish IP address up date, restart connection to module (OK).

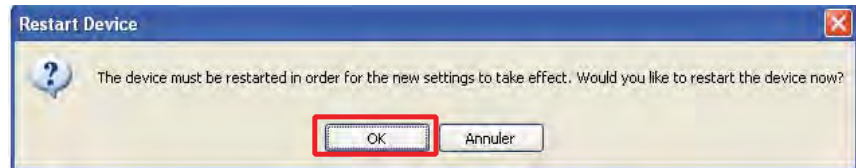

③ Allocate a serial port to Wi-Fi module

Launch «  Digi Real port » software.

Wi-Fi module is detected.

Otherwise, launch again detection: press on « Refresh ».

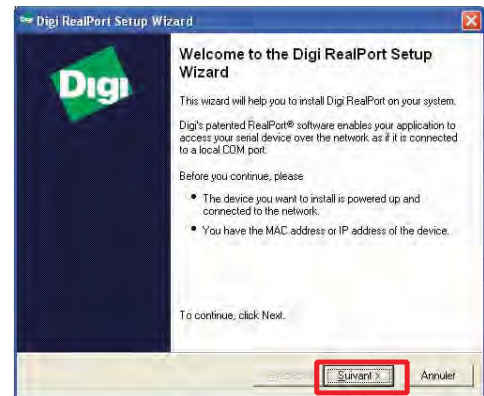

Select Wi-Fi module to allocate to a PC serial port, then « Next ».

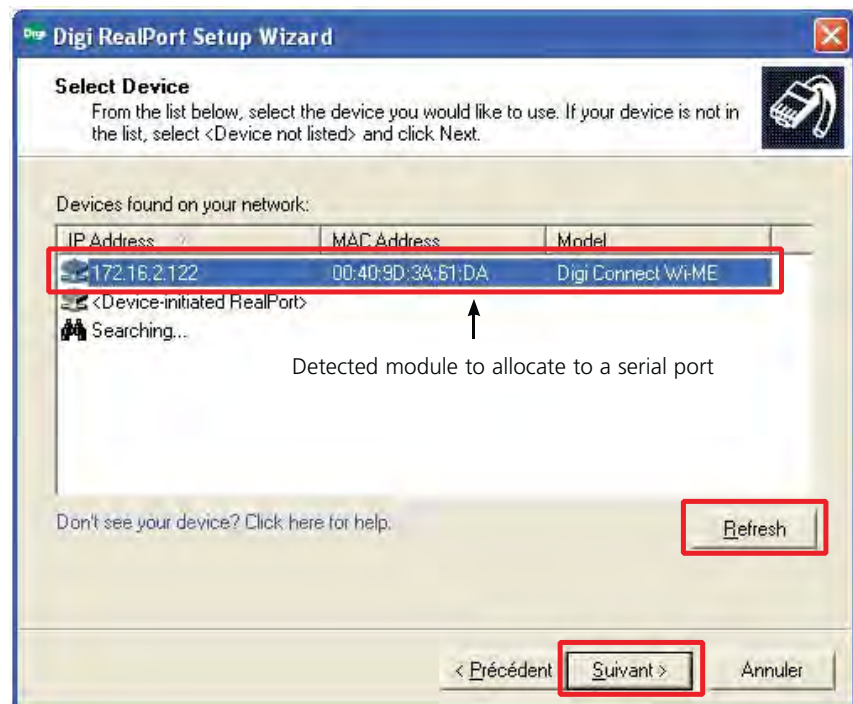

Wi-Fi

Select Wi-Fi module.

Select a serial port number in the list and then « Finish ».

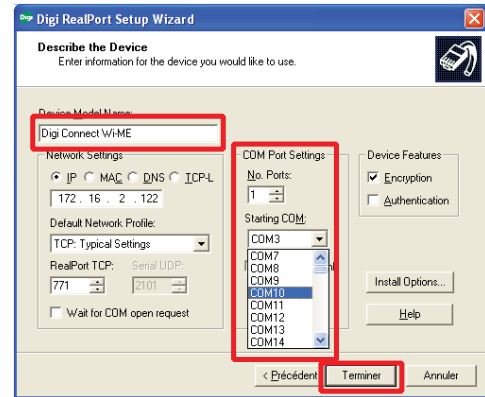

The Wi-Fi virtual port selected is in the process of being created.



Wi-Fi virtual port is created.

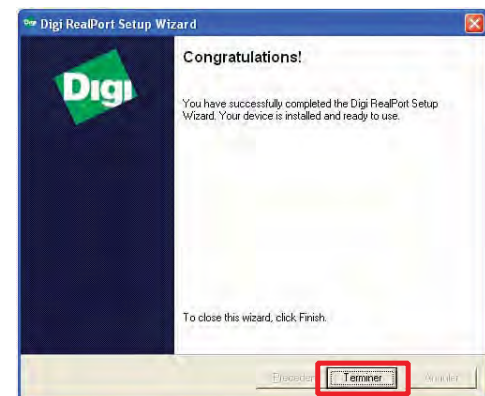

Wi-Fi

④ **Check the created Wi-Fi module port (optional)**

You can check the new created port in your device manager.

Control panel → System →
Hardware → Device manager
→ Ports (COM and LPT)

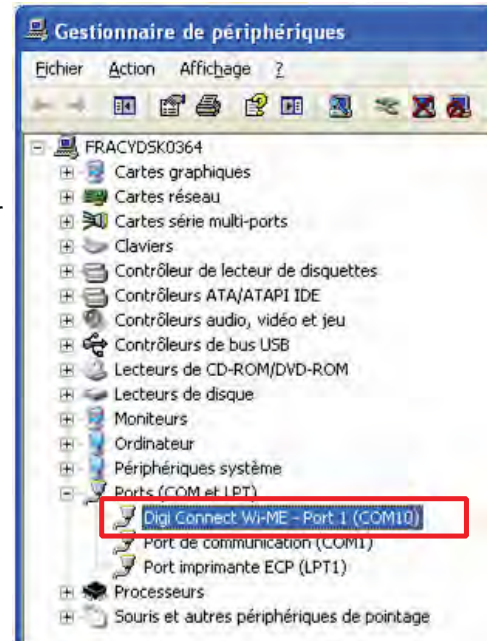

⑤ **Wi-Fi module uninstallation** Select Wi-Fi module allocated to a PC serial port, then “Uninstall”.

Ethernet

Purpose Ethernet allows, to an user, communicating with his/her detector through an Ethernet network.

Connection Refer to  **B 400**.

Female Ethernet plug placed on detector.

Ethernet cable not delivered with interface:
at customer's charge.



Compatibility with the other interfaces

- If leak detector is also equipped with Bluetooth module, user cannot select simultaneously Bluetooth and Ethernet.
- It is not necessary to remove Bluetooth module when Ethernet is used.

Preliminary conditions

- It is necessary to allocate Ethernet to serial link 2 in control panel Advanced menu ( **C 406**) to active it: set « Network ».
- To use Ethernet, user must first load on his/her PC Ethernet driver delivered in the operating manual CD Rom.

Use with a PC

- After driver is loaded and set, user has a virtual RS 232 serial link allowing controlling the leak detector from a PC.
- It is possible to talk in direct order mode Ethernet using TELNET protocol.

Ethernet settings

Displays below are given as example (Windows XP). They can be changed according to PC system.

Electronic module/PC link configuration

Connect a crossed Ethernet cable (obligatory) between Ethernet port and your PC.

Ethernet

Ethernet module configuration

① Load driver

« Digi Device Discovery.exe » driver is delivered in the operating manual CDRom of your product.

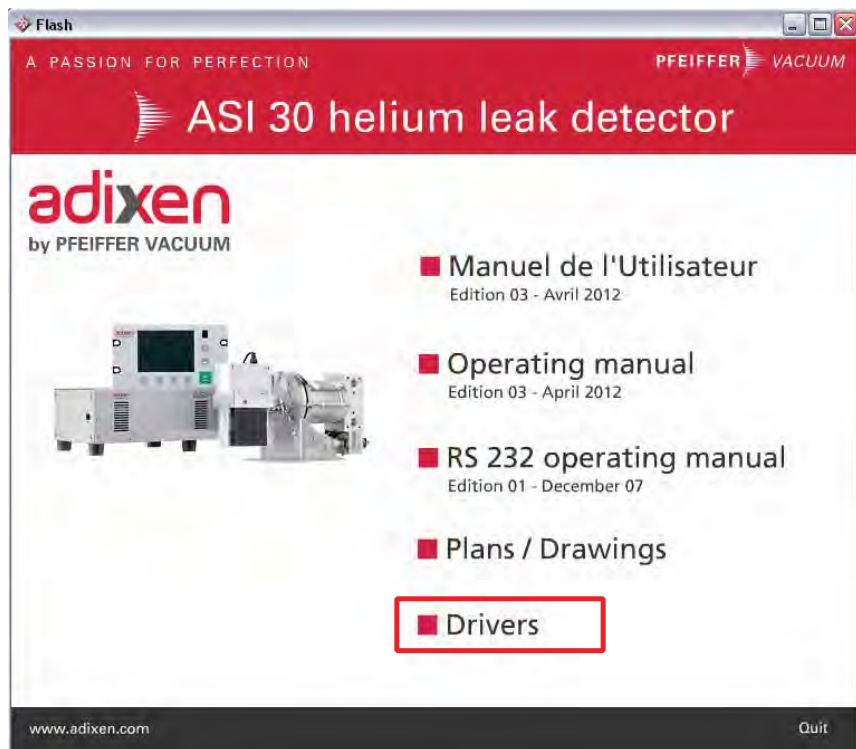

② Change Ethernet module IP address

Launch «  Digi Device Discovery » software.

Ethernet module is detected.

If not, launch again detection: press on « Refresh view ».

Note: Ethernet module appears in menus with « Digi Connect Wi-ME » name.

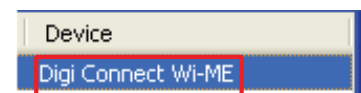

Ethernet

- If detected module IP address is not correct, symbol  appears.

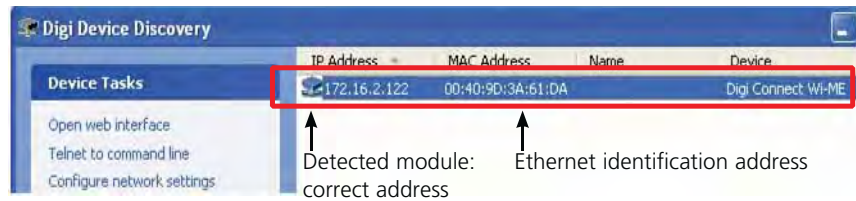

Note : MAC address is unique and peculiar to each Ethernet module. It is indicated on the module and/or identification label stuck on the electronic module ( B 112). To select a detector among several detectors, select MAC address of the wanted detector.

- If the module IP address detected is not correct, symbol  appears.

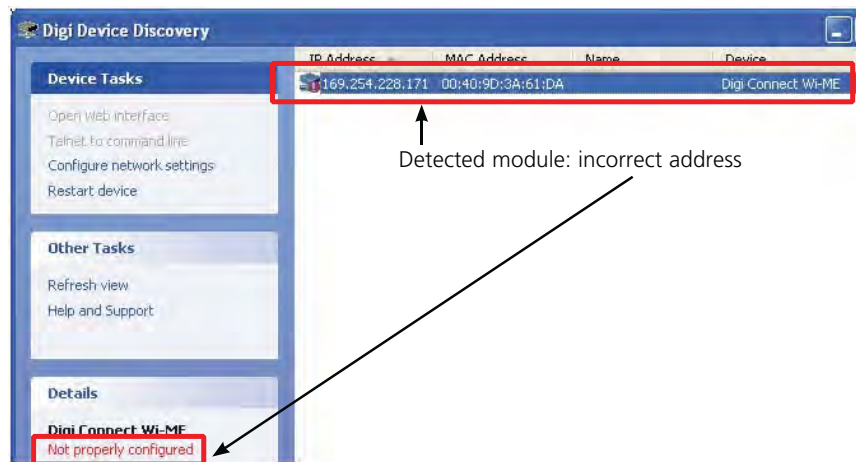

Change module IP address to be in the same sub network as your PC.



Ethernet

Save new addresses.

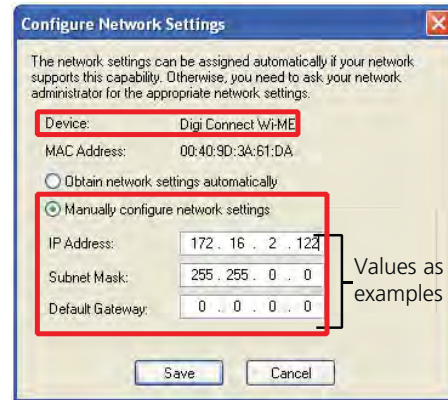

Contact your Network administrator for IP addresses to set.

To finish IP address up date, restart connection to module (OK).

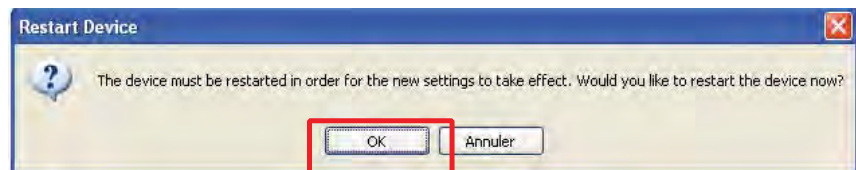

③ Allocate a serial port to Ethernet module

Launch «  Digi Real port » software.

Ethernet module is detected.

Otherwise, launch again detection: press on « Refresh ».

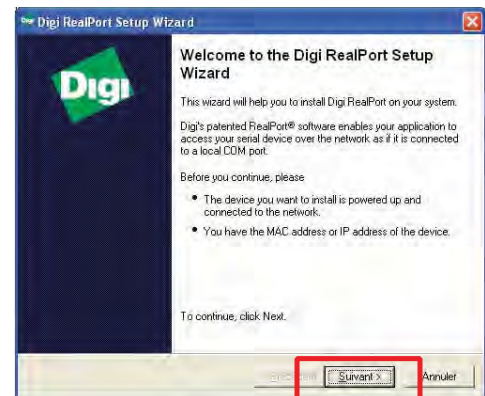

Ethernet

Select Ethernet module to allocate to a PC serial port, then « Next ».

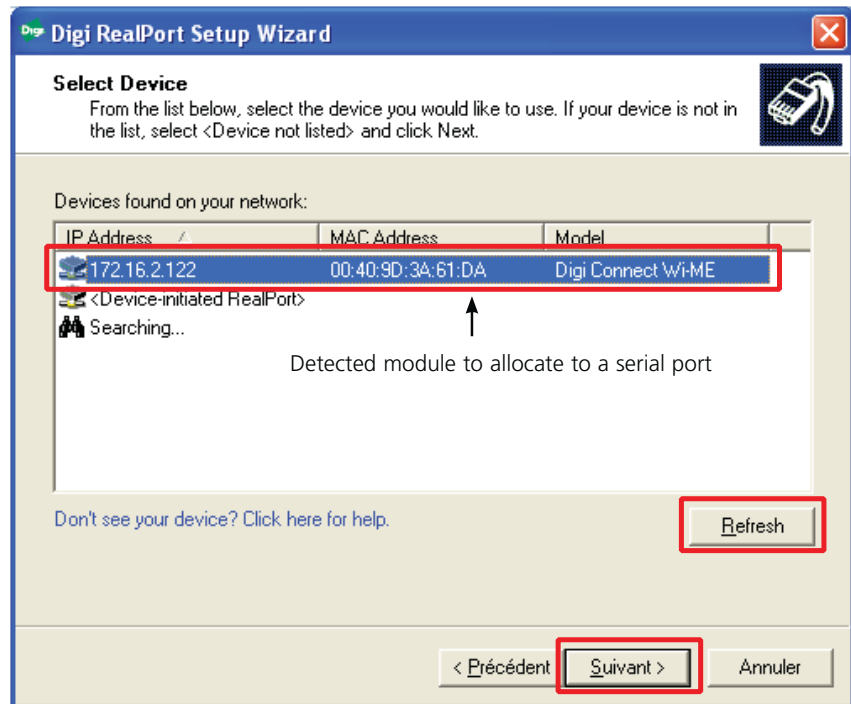

Select Ethernet module.

Select a serial port number in the list and then « Finish ».

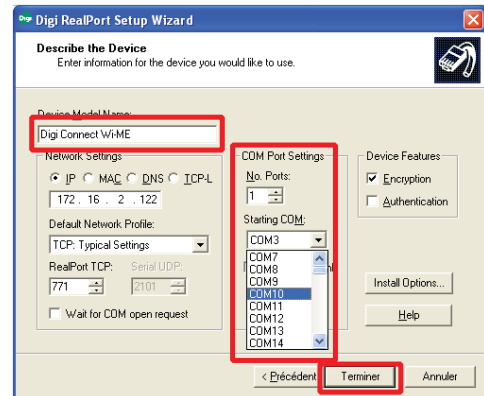

The Ethernet virtual port selected is in the process of being created.



Ethernet

Ethernet virtual port is created.

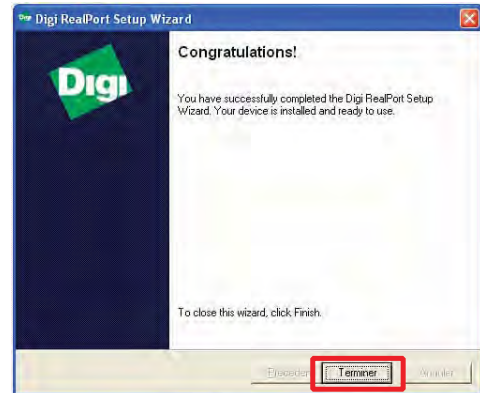

④ Check the Ethernet module port created (optional)

You can check the new created port in your device manager.

Control panel → System → Hardware → Device manager → Ports (COM and LPT)

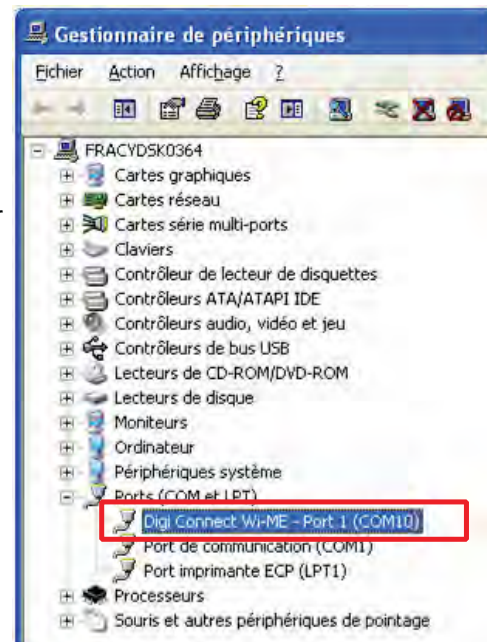

⑤ Ethernet module uninstallation

Select Ethernet module allocated to a PC serial port, then "Uninstall".

Bluetooth

Definition Refer to  **A 300**.



Installation Refer to  **B 240**.

Compatibility with the other interfaces

- If leak detector is also equipped with Wi-Fi or Ethernet module, user cannot select simultaneously Bluetooth and Wi-Fi/Ethernet.
- We can select simultaneously Bluetooth (serial link 2) and USB (serial link 1).
- We can select simultaneously Bluetooth (serial link 2) and Profibus (serial link 1).

Preliminary conditions

- It is necessary to allocate Bluetooth to serial link 2 in control panel Advanced menu ( **C 406**) to active it: set « Bluetooth ».

Use with a PC

Bluetooth modules integrated in PC have drivers allowing an automatic serial link creation. This serial link allows controlling leak detector with user's RS 232 software.

Use with a PDA

The Bluetooth use requires ASM Pocket application installation ASM Pocket ( **G 800**) in the PDA. ASM Pocket is free of charge on www.adixen.com site.

Its use area is from 10 to 20 meters (free field).

Equipment

The PDA is at customer's charge. The customer must configure the PDA to be used with the leak detector.

Minimal configuration of PDA to use:

- Windows Mobile 5 mini / Windows Pocket PC 2003

Bluetooth

Connection The user must configure his/her PDA so that the PDA detects Bluetooth module(s) installed on the leak detector(s), in its use area (free field: 10 meters maximum).

After:

- the PDA may connect with only one leak detector at the same time.
- Once connected to a PDA, the leak detector is not “visible” by others PDA.

Interface and recognition and setting mode are peculiar to each PDA. The following screens are given for example.

Reminder: detector switched on and Bluetooth installed.

All recognized leak detectors in the PDA area are identified by the number indicated on the Bluetooth.

Example :

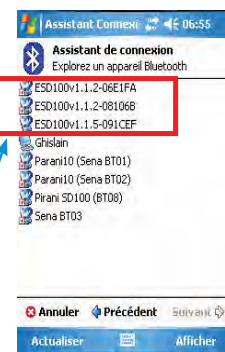
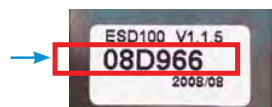

This number is unique.
In this example, the PDA has identified 3 numbers.

It is indicated on the module and/or identification label stuck near detector identification label ( B 112).

To select a PDA among several PDA, select the number of the wanted PDA.

Bluetooth

Connection (ctd)

- Select the desired leak detector.
- Password «clé de passe» to keyboard: **5555**
- The connection set up between PDA and leak detector Bluetooth.
- The connection between PDA and leak detector Bluetooth is memorized.
- Activate the connection.

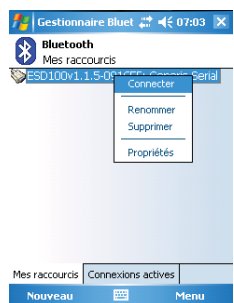
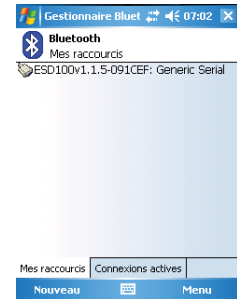
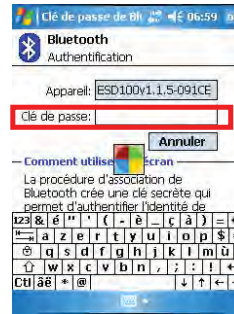

Starting-up / Switching off of the leak detector

Connecting the detector to the installation

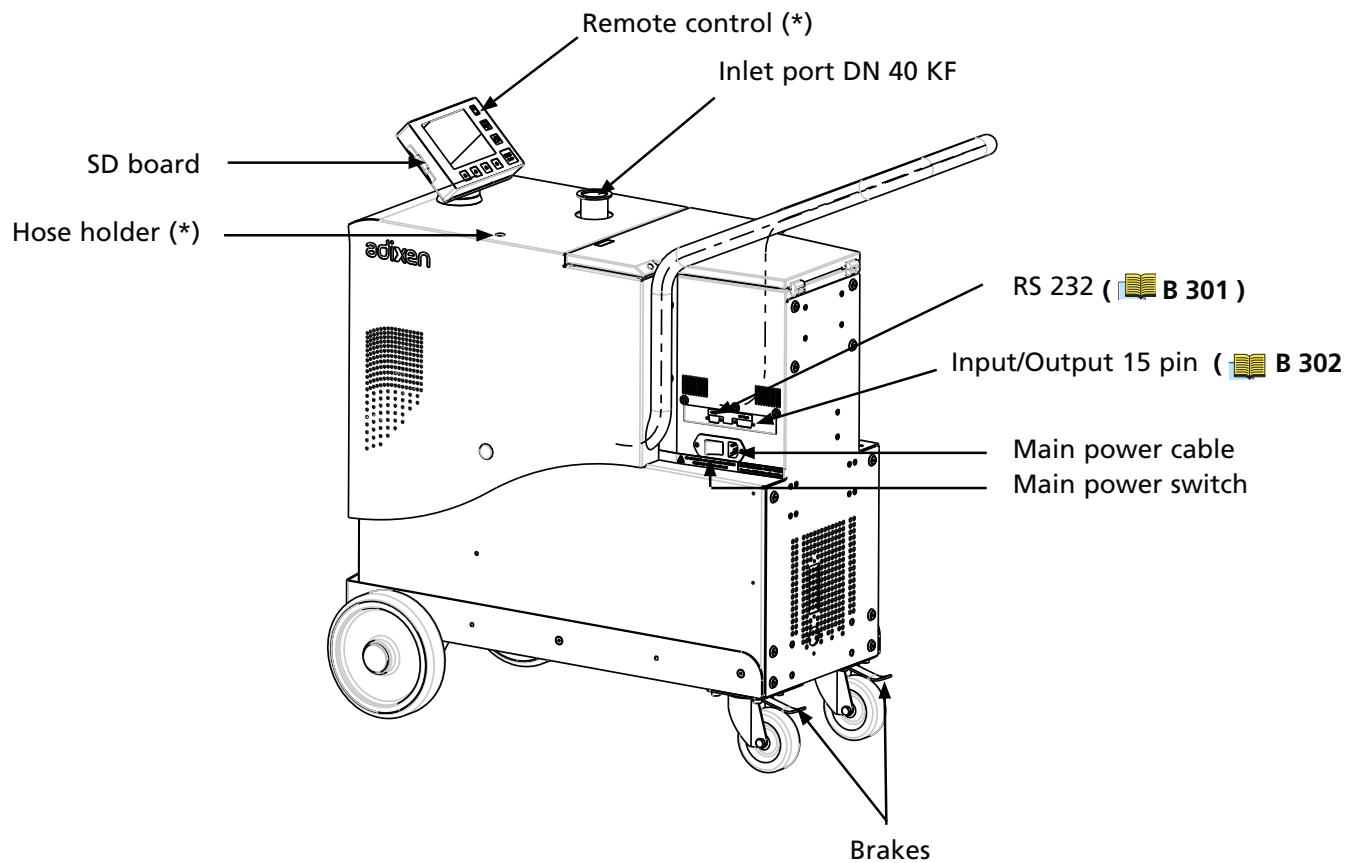

(*) Accessory (A 400): to order separately.

Starting-up / Switching off of the leak detector

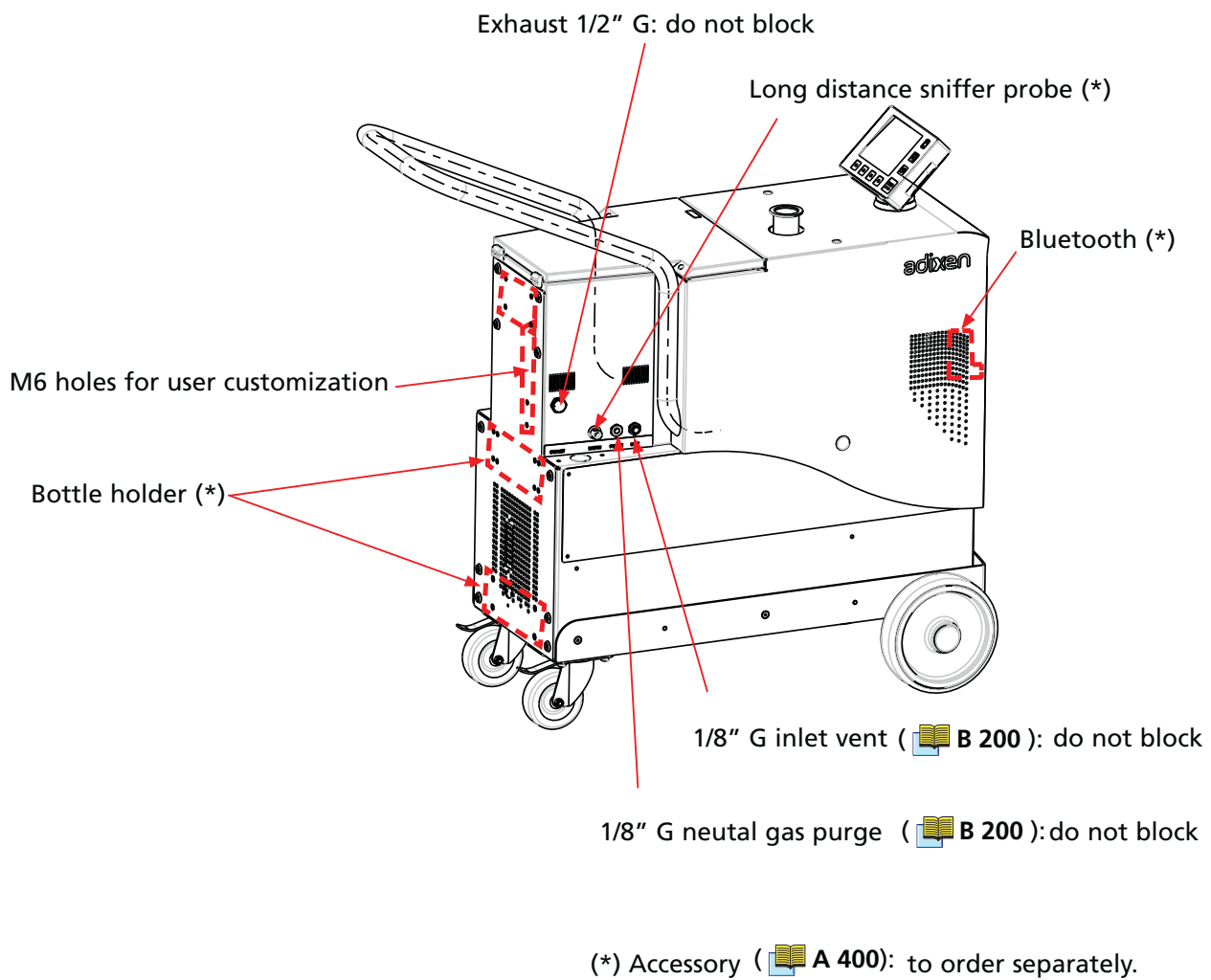

Starting-up / Switching off of the leak detector

Use position The leak detector must be used in horizontal position, inlet port on the top.

CAUTION

During leak detector use (apart from handling), make sure brakes are activated ( E 650).

Storage The ASM 380 has:
- a storage box
- hoses storage box

The kit maintenance can be store in the hoses storage box.

Boxes access: lift the detector cover.

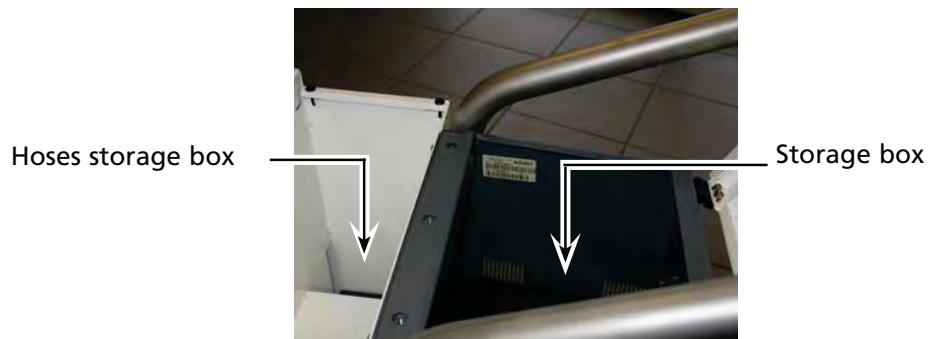

Control panel fixing The leak detector is delivered with the control panel screwed on its holder.



Starting-up / Switching off of the leak detector

Control panel fixing (Cdt)

- To free it, with a range of max. cable tight 1 meter, unscrew the 2 fixing screws.

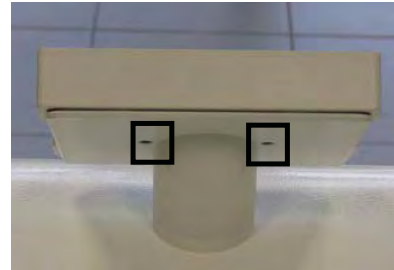

- Keep screws and bolts to fix again if necessary the control panel on its holder.



- The control panel is magnetized: so, you can take it on all metallic surface.

Hose holder fixing

- DN 40 KF hose holder (delivered alone without centering ring, o'ring and clamp) allows to fix the hose connecting the inlet detector to the installation to be tested, during a moving or a extended storage, and to keep under vacuum inlet detector and hose.



- The holder is fixed instead of a lifting ring: unscrew one lifting ring and screw the holder at its place.

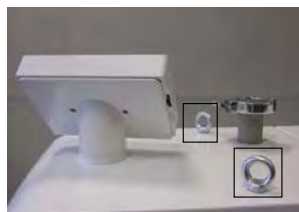

Starting-up / Switching off of the leak detector

- Cover locking**
- It is possible to lock the leak detector cover (access to storage box and hoses storage box) with a padlock (at the customer's charge).
 - Raise the leak detector cover.

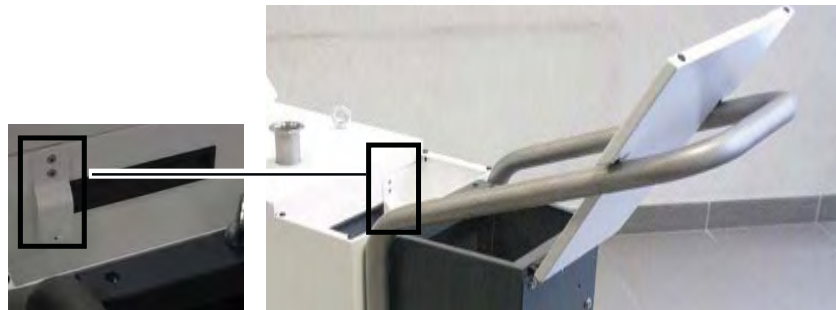

- Unscrew the locking plate: turn it and screw it again.

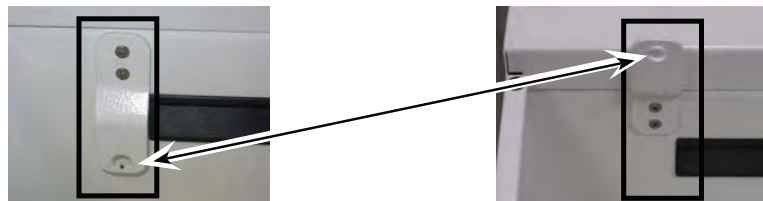

- Remove the path window of the locking plate with a small flat tool (screwdriver for example). Put a padlock.



Starting-up / Switching off of the leak detector

Ventilation

CAUTION

During its use:

- Keep free area a 10 cm area minimum around leak detector,
- Store anything under the detector.

Basic vacuum rules for the installation connecting

- We recommend connecting the adixen leak detectors using pipes with a diameter equal to the inlet port.
- The connection between the piece to be tested and the leak detector must be as short as possible, direct, perfectly light (which means it is important to design adapted tools to connect the piece).
- The volume between the tested part and the test chamber (free volume) must be as small as possible.
- The length of the connection influence the "response time". It means that if the connection is very long (more than 1.5 meter with diameter equal to the inlet of the detector) the signal will move very slowly.
- Don't use plastic hoses for compressed air.
- Check carefully that the material doesn't allow helium permeation.
- Test only clean and dry parts: no trace of water vapors, paints, detergents or rinsing products.

Use conditions Respect the safety instructions relating to user ( B 100) .

Starting-up / Switching off of the leak detector

Starting up Your leak detector is multivoltage (from 90 to 240 V \pm 10 %): connect it to the power plug.

1st starting up During the first starting up after reception, you can adjust the unit, the date, the hour and the language of the displays and the digital voice.

These parameters can afterward be modified if necessary ( C 303).

Starting up after an unused/ storage period After an unused storage period, there is additional time at the start-up for outgassing.

The countdown before using the leak detector is displayed.

The operator can cancel this additional time by pressing  . But it is not recommended.

It is not abnormal that after an unused storage period, the calibration fails. In this case, wait 30 minutes and do it again.

Getting started with the leak detector If you have never used a leak detector, know that there is no risk of starting your detector and discovering the menus even without particular knowledge. But we advise to read chapters B and C.

If you have already used this type of product, do not hesitate to discover the menus by yourself. Read the chapter C.

Switching off recommended The leak detector can be switched off at any time by depressing the main power switch to 0 (OFF) but it is advised (especially when the leak detector may not be used for an extended period of time) to stop it following the procedure described below.

- Place the blank-off flange on the inlet port or link the hose holder to the detector inlet port ( B 240).
- Start a test cycle.
- Wait until the leak detector reaches the more sensitive test mode
- Make sure that the inlet vent is OFF.
- Stop the test cycle.
- Stop the leak detector.
- Wait before moving the detector so as to make sure of the complete secondary pump stop.

The leak detector is so under vacuum avoiding an important degassing time in a future use.



ASM 380 - Operating instructions Detailed contents

Preliminary remarks Throughout this operating manual, you could find this type of message **“Setting” menus arborescence**  **C 600**: it refers to a specific chapter of the operating manual. Please read it for further information.

| | |
|--------------|--|
| C 100 | <i>Getting started with the leak detector</i> |
|--------------|--|

- Start/stop a test
- To familiarize oneself with the control panel

| | |
|--------------|------------------------------|
| C 110 | <i>Perform a test</i> |
|--------------|------------------------------|

| | |
|--------------|-----------------------------|
| C 200 | <i>Control panel</i> |
|--------------|-----------------------------|

- Description
- Application windows
- Function keys

| | |
|--------------|-------------------------------|
| C 300 | <i>Graphic display</i> |
|--------------|-------------------------------|

- Purpose
- Setting
- Deletion
- Recording
- Recording visualization
- Plotting saving

| | |
|--------------|------------------------|
| C 400 | <i>Settings</i> |
|--------------|------------------------|

- Purpose
- Legend
- Value adjustment from the control panel

| | |
|--------------|-------------------------------|
| C 401 | <i>Set points Menu</i> |
|--------------|-------------------------------|

- Purpose
- Audio alarm and digital voice set points
- He max.
- Set points
- Probe clogged



Operation

ASM 380 - Operating instructions Detailed contents

C 402

Test Menu

- Purpose
- Test methods
- Correction factor
- Test mode
- Cycle end function
- Air inlet

C 403

Spectro Menu

- Purpose
- Tracer gas
- Fil. Margin
- Calibrated leak

C 404

Maintenance Menu

- Purpose
- Filament 1-2
- Cycles counter
- Primary pump - Secondary pump
- Events history
- Calibrations history
- Infos

C 405

Configuration Menu

- Purpose
- Hour / Date / Unit / Language
- Function Keys
- Applicative windows
- Screen settings
- Access Password

C 406

Advanced Menu

- Purpose
- Leak detection menu
- Leak detection: Start-up time delay
- Leak detection: Background suppression function
- Leak detection: Zero activation function
- Leak detection: Calibration
- Leak detection: Analyzer cell
- Leak detection: Memo function
- Leak detection: Internal Pirani calibration
- Input/Output menu
- Input/Output: Serial link 1
- Input/Output: Serial link 2
- Input/Output: I/O connector
- SD card menu
- Load/Save Detect. Param.



ASM 380 - Operating instructions Detailed contents

C 500 *Factory configuration of the leak detector parameters*

- Parameters configuration

C 600 *"Setting" menus arborescence*

C 700 *Remote control (accessory)*

- Interface
- Connecting
- Choice
- Use and display

C 800 *Wireless remote control (accessory)*

- Supplies
- Technical characteristics
- Remote control presentation
- Operation display
- Main menu
- Connection
- Use

C 900 *Long distance sniffer probe and Helium spray gun (accessories)*

Getting started with the leak detector

Safely for your leak detector and yourself, you can realize quickly a vacuum test and discover your leak detector.

Refer to the sheet  **B 300** for the installation and detector starting up in case of doubt.

Start/stop a test



- Place the blank-off flange on the detector inlet (detector state on delivery).
- Start a test.
- The helium signal displays the measured leak value: it corresponds in our case to the detector background.
- Stop the test.
- To remove the blank-off flange, do an air inlet ( **C 402**).

To familiarize oneself with the control panel

Refer to the sheet  **C 200** for the control panel description.



- Press on the key  several times to familiarize with the application windows.



- Press on the key  several times to discover the 3 function keys levels proposed.













- At each level, press on each function key (on the control panel or with the key  opposite) to discover its action.

Perform a test

By default, the leak detector is set to perform a helium hard vacuum test, in the most sensitive test mode.

2 tests modes are proposed: hard vacuum and sniffing ( **A 200**).

| Hard vacuum test mode | Sniffing test mode |
|--|--|
|  <p>Select the hard vacuum test mode ( C 402).</p> |  <p>Select the sniffing test mode ( C 402).</p> |
| <p>Connect the part to be tested to the leak detector inlet port or put the part in the test chamber connected to the leak detector.</p> | <p>While the leak detector is in stand-by, connect the sniffer probe (accessory to be purchased separately) to the sniffer port of the leak detector.</p> |
|  <p>Set the reject point ( C 401).</p> | |
|  <p>Start a test.</p> | |
| <p>The leak value measured displays.</p> | |
|  <p>Stop the test.</p> <p>The detector returns automatically to stand-by mode.</p> | |
| <p>If Memo function is activated and a printer is connected to the detector, a test ticket will be printed automatically after the test ( C 406).</p> | |

- Notes**
- In stand-by mode, the leak value displayed is the helium background value.
 - If the automatic cycle function is activated, the test end is different ( **C 304**).

Control panel

Description

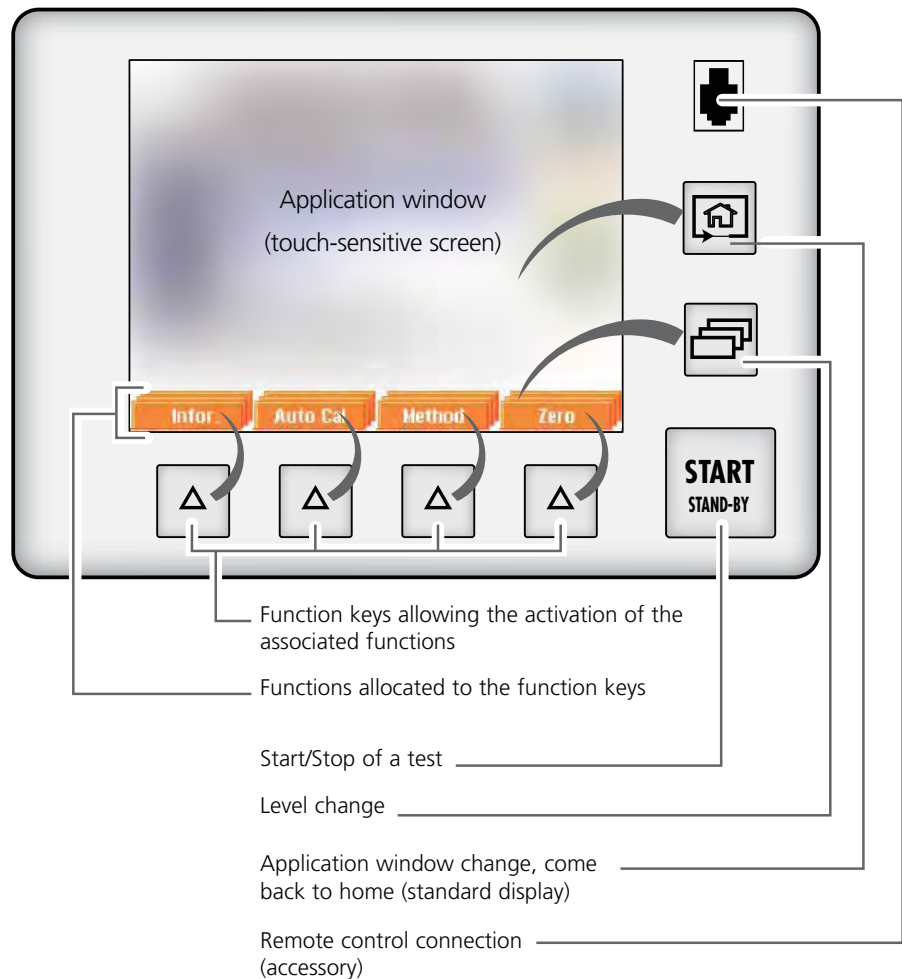

Use a finger or any object with end rounded off on the touch-sensitive screen. Do not use sharp objects (screwdriver for example).

Contrast/Luminosity  C 403

Screensaver  C 405

Any press on the screen will reactivate the display.

If the touch-sensitive screen is defective, the functions remain accessible by keys: use the RS 232 to pilot/set the detector or the SD card (setting only).

Control panel

Application windows

The windows content are given for example. Depending on leak detector and parameters, the display can be different.

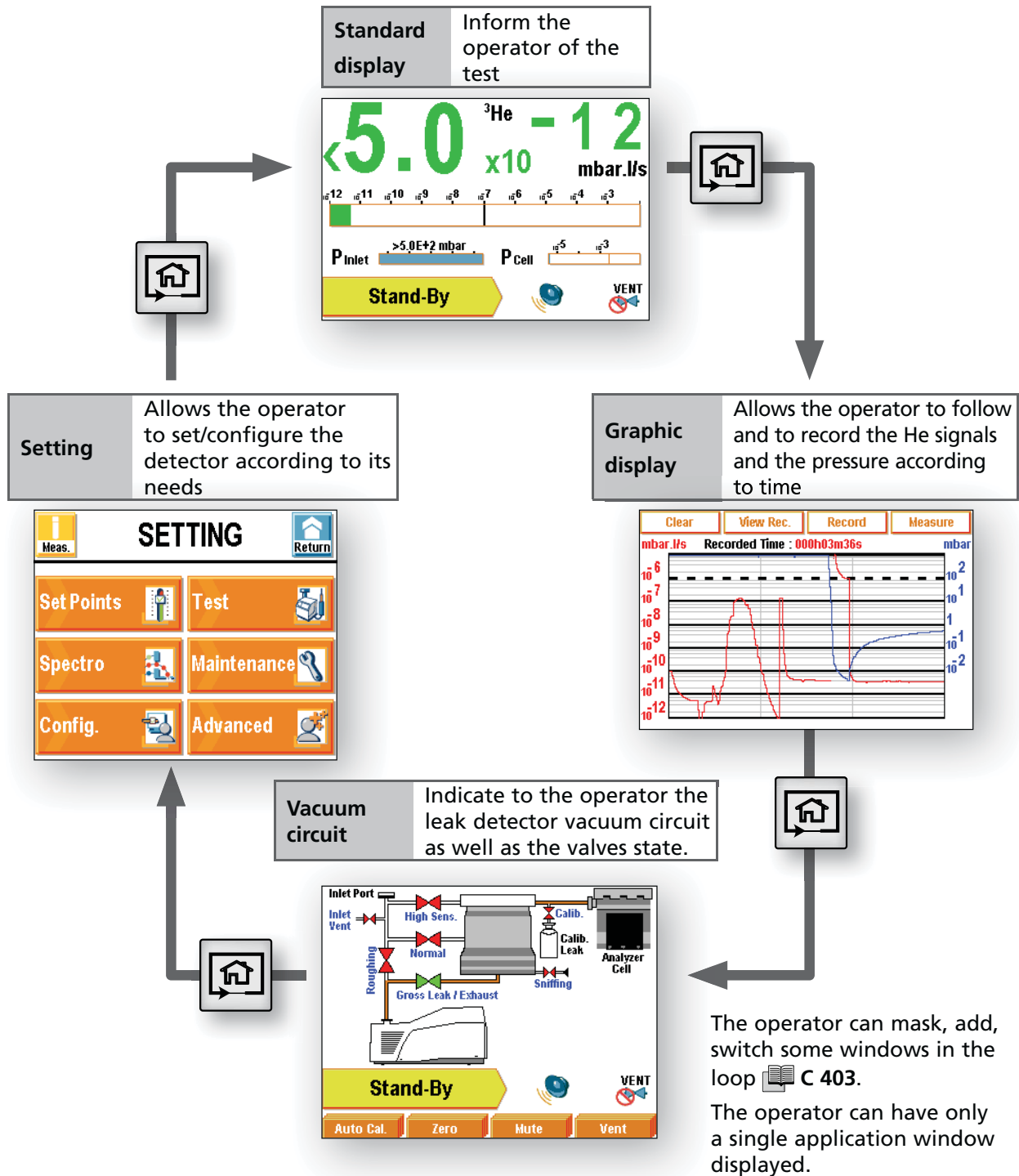

Control panel

Standard display Display most generally used to do a test.

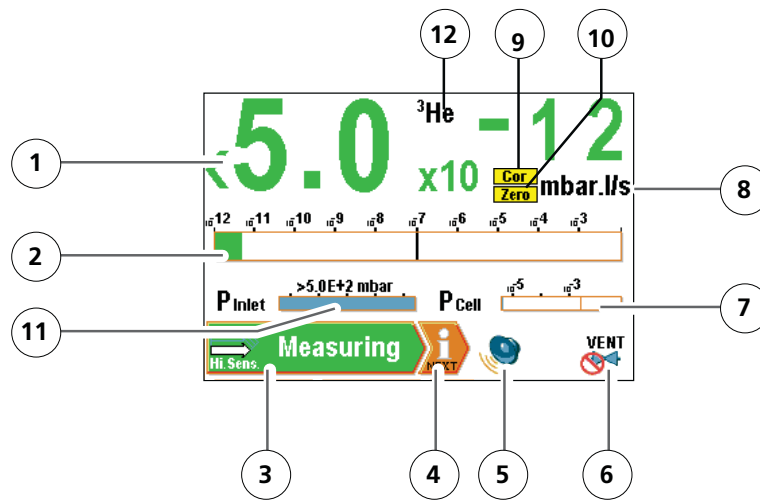

| | |
|----|---|
| 1 | He signal digital display (green \leq reject set point < red) |
| 2 | He signal bargraph display (adjustable scale) |
| 3 | Detector state and detection mode |
| 4 | Default information access |
| 5 | Mute function activated/desactivated indicator |
| 6 | Inlet vent function activated/desactivated indicator (📖 C 402) |
| 7 | Cell pressure bargraph display |
| 8 | Measure unit of the leak flow |
| 9 | Signal correction function activated indicator |
| 10 | Zero function activated indicator |
| 11 | Detector inlet pressure display (coherent unit with the leak flow unit) |
| 12 | Tracer gas (if ³ He or Hy) |

Control panel

Graphic display Display used to facilitate the tests requiring a high precision, by showing the measured signal and its evolution.

C 300

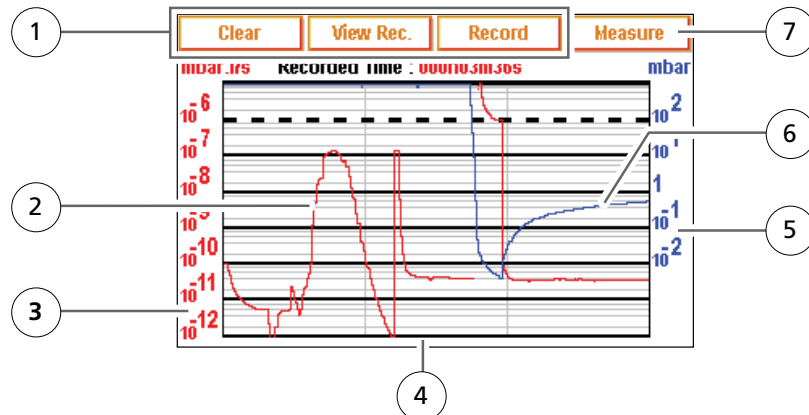

| | |
|---|--------------------------------------|
| 1 | Delete/visualisate/record a plotting |
| 2 | Tracer gas signal display (in red) |
| 3 | Tracer gas signal scale (in red) |
| 4 | Time scale |
| 5 | Inlet pressure scale (in blue) |
| 6 | Inlet pressure display (in blue) |
| 7 | Measure/masking display: → |

Vacuum circuit Display used to follow the valves state during a test and so to have a better knowledge of the detector functioning.

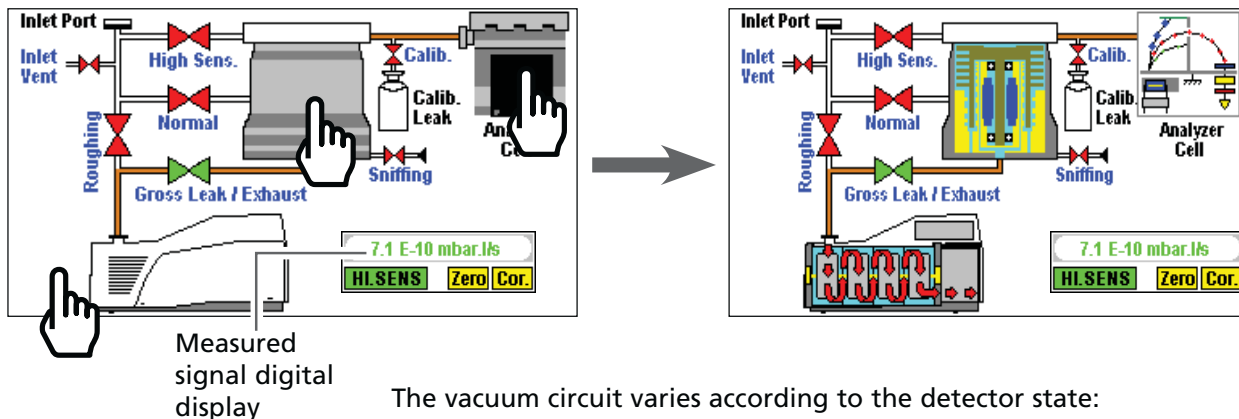

The vacuum circuit varies according to the detector state:





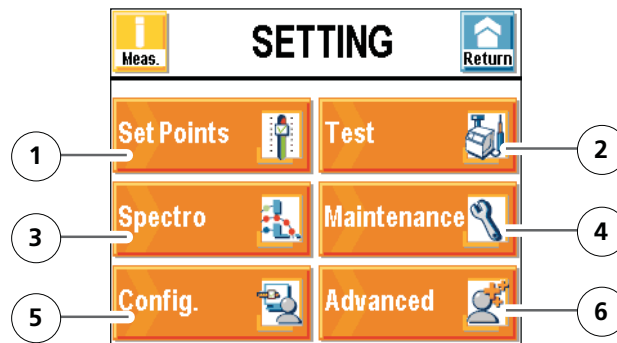

- green: valve opened
- red: valve closed.

It is not possible to control valves.



Control panel

 **Setting** Menu allowing the detector setting access.
C 400... C 406



| | | |
|---|--|---|
| 1 | Set points setting: reject set point, audio level, digital voice, He max. |  C 401 |
| 2 | Method and test mode selection. Inlet vent management. Correction value. Cycle end. |  C 402 |
| 3 | Tracer gas selection. Calibrated leak setting. |  C 403 |
| 4 | Maintenances planning |  C 404 |
| 5 | Detector configuration for the user: language, unit, password, function keys, applicative windows |  C 405 |
| 6 | Advanced functions* kept for specific detector uses. It is necessary to read the operating manual. *advanced setting required a good leak detection knowledge: cell setting, pressure gauge, etc. |  C 406 |



• *Setting" menu is also accessible from any window by pressing simultaneously the keys  and .*

Control panel

"Measure" display This window could be display as soon as the key  is displayed.

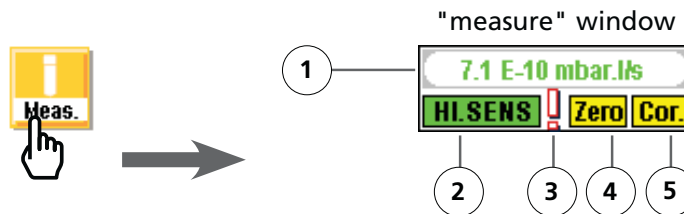

| | |
|---|---|
| 1 | He signal digital display (green \leq reject set point < red) |
| 2 | Detector state |
| 3 | Default information indicator |
| 4 | Zero function activated indicator |
| 5 | Signal correction function activated indicator |

- Scales (3), (4), (5) are adjustable by pressing on the graph.
- The operator could move the "measure" window on the touch-sensitive screen: press on the measure window with the finger and move this one on the screen.

Control panel

Function keys 12 function keys, customized by the operator, divided on 3 lines allow:

- either activate directly the function, without use "Setting" menu,
- or adjust a set point,
- or display informations,
- or give or not the access to a limited number of functions.

3 standard configurations are proposed meeting the majority of the user's need (📖 C 405).

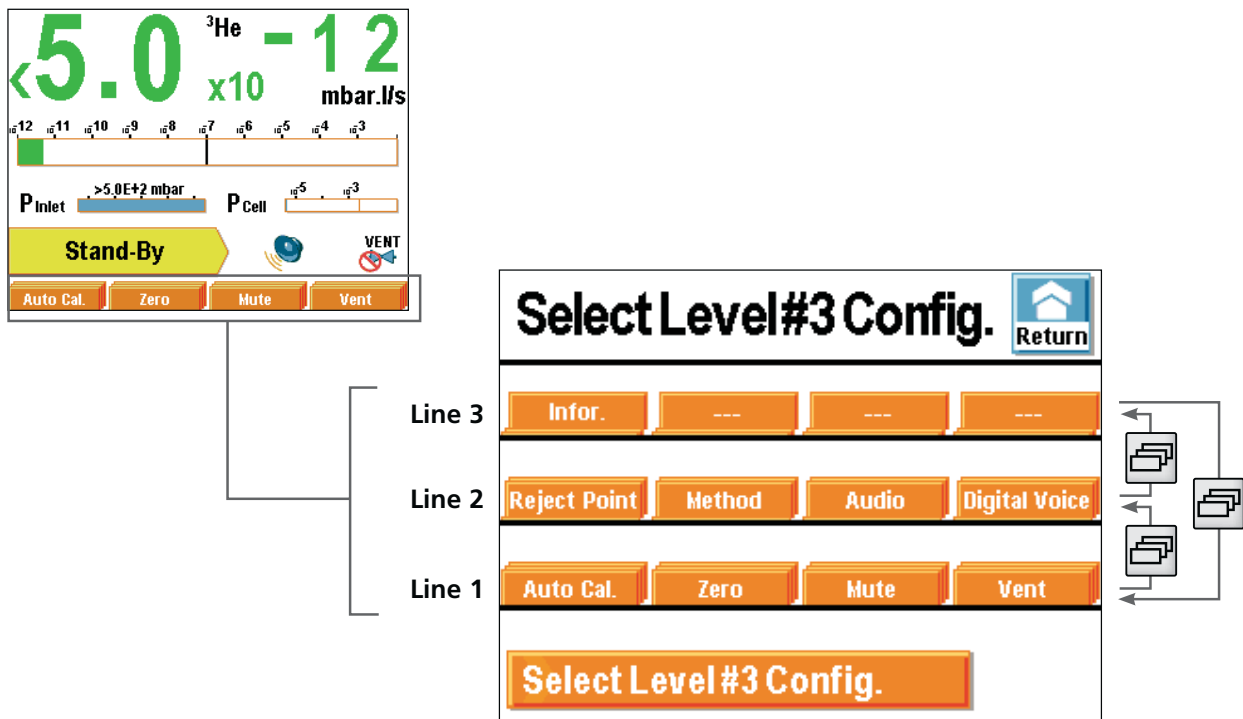



If necessary, the operator can customize the function keys. (📖 C 405).

Graphic display

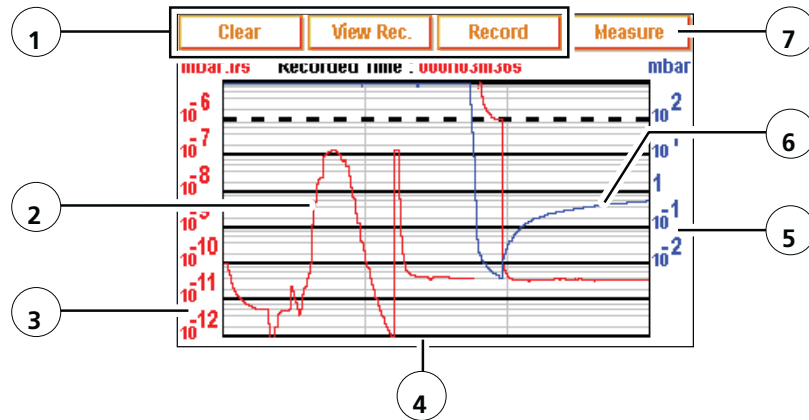
Purpose Graphic display allows to the operator to follow the measured signal and/or inlet pressure evolution in the time and to record it.



| | |
|---|--|
| 1 | Delete/visualize/record a plotting |
| 2 | Tracer gas signal display (in red) |
| 3 | Tracer gas signal scale (in red) |
| 4 | Time scale |
| 5 | Inlet pressure scale (in blue) |
| 6 | Inlet pressure display (in blue): pressure = 10^3 constantly if there is no external gauge connected |
| 7 | Measure displayed/hidden:  →  |

- Scales (3), (4), (5), are adjustable by pressing on the graph.
- The operator could move the "measure" window on the touch-sensitive screen: press on the measure window with the finger and move this one on the screen.

Graphic display

Setting Access to the graph setting menu by pressing on the graph.

Display

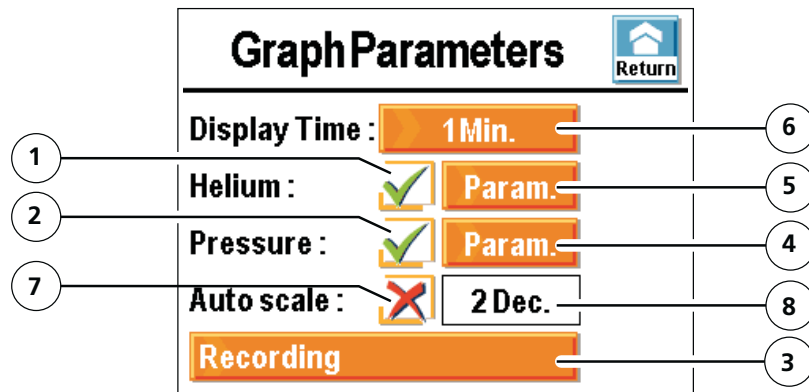

| | |
|---|---|
| 1 | Display/mask the measured signal |
| 2 | Display/mask the inlet pressure |
| 3 | Recording time parameters |
| 4 | Inlet pressure scale parameters |
| 5 | He signal scale parameters (if automatic scale deactivated) |
| 6 | Screen display time speed |
| 7 | Activate/Deactivate automatic scale |
| 8 | Automatic scale setting |

Automatic scale Automatic scale allows displaying measured signal centred on 2 or 4 decades.

Scale moves in function of measured signal. If automatic scale is set, it is no more possible to set the He signal scale (1):

Example : He signal = $5 \cdot 10^{-7}$ mbar l/s

- automatic scale 2 decades → scale from $5 \cdot 10^{-6}$ to $5 \cdot 10^{-8}$ mbar l/s
- automatic scale 4 decades → scale from $5 \cdot 10^{-5}$ to $5 \cdot 10^{-9}$ mbar l/s

Graphic display

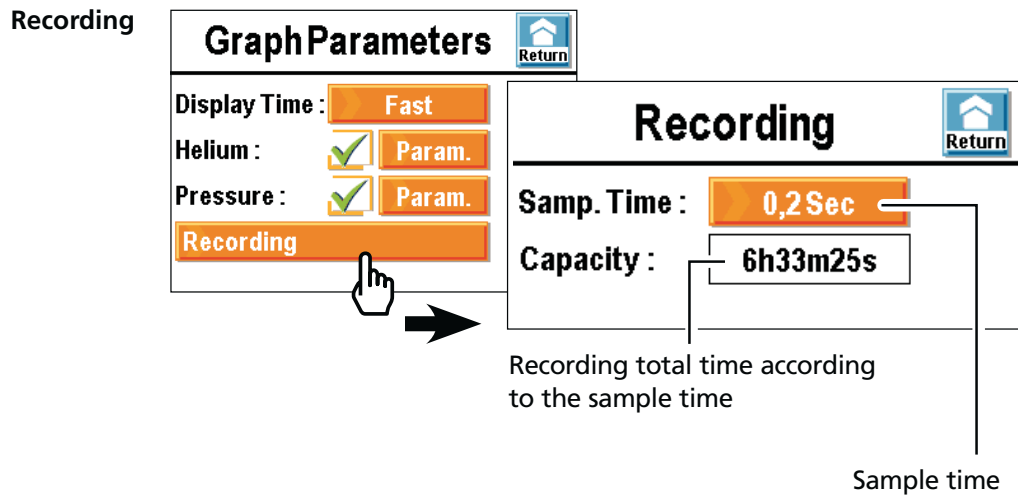

| Sample time | Maximum capacity | File size |
|-------------|--------------------|-----------|
| 0.2 s | 6 hours 33 minutes | ≈ 7 Mo |
| 30 s | 983 hours | |

Graphic display

Deletion  Deletion of the screen in progress.

Recording Recording allows to record measure points in the control panel: **it does not save these points.** (see § "Saving the recording").

The recorded points will be lost if the leak detector is switch off: if necessary, save the recording them on the SD card.



- Change if necessary the recording parameters.

- Start a recording 

All points displayed on the graph before the recording start will not be recorded.

- Stop recording 

- To display recording 

- If the memory is not delete between 2 recordings, (), all the successive recordings are consecutive on the recorded graph. A cursor  indicates the end of each recording.

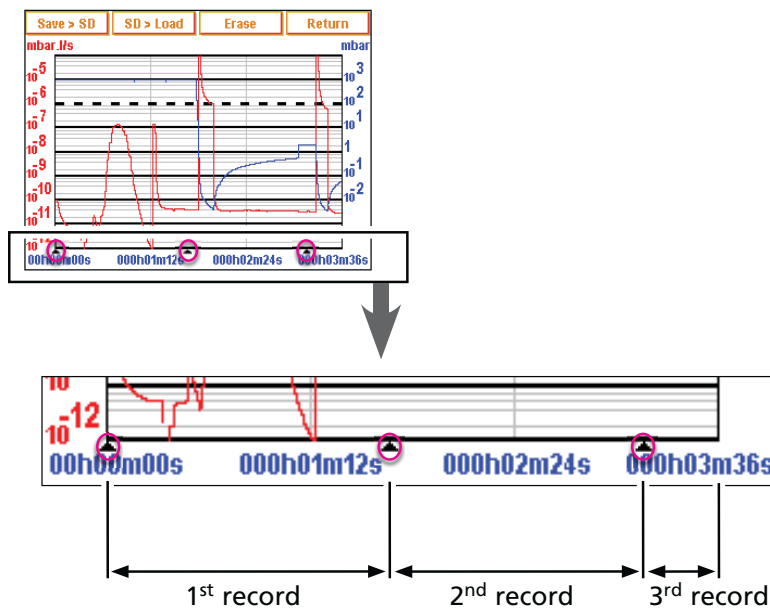

Graphic display

- Recording (ctd)**
- When the memory is full and if a recording is in progress, recording is automatically stopped and the message below displays:

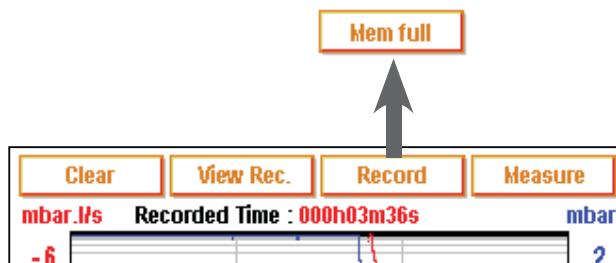

- During a recording, all the detector functions are available.
- Every detector switching off or control panel disconnection will deletes the memory: if necessary, save the recorded plotting on the SD card before these operations.

Recording visualization



- At any time, during a plotting, the operator can visualize a plotting part already recorded or do a zoom, without stop the plotting in progress.

View Rec. Visualisation of the plottings recorded done since the last **Clear** or the last switching on.

Visualisation of a plotting realized.

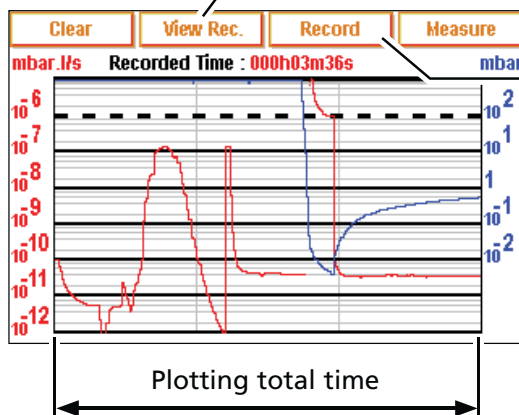

Deletion of the plottings recordings.

- If any plotting has been done, the message below appears:

Nothing recording

OK

Graphic display

Zoom ■ Zoom is only possible on a recorded plotting.



| Zoom on | Zoom off |
|---|--|
| <p>Define the zone to enlarge (point 1 then point 2) :</p> | <p>Press twice on the screen as indicated below:</p> |
| | |
| | |
| | |
| <p>Several successive zooms are possible (except in a same range).</p> <p> • Adjust if necessary the zone to enlarge by pulling the corners or sides of the zone with your finger.</p> | <p>Come back to the previous screen if several zooms have been done, repeat the operation until basic graph come back.</p> |

Graphic display

Measure ■ Exact measure of one point only possible on a recorded plotting.

1 - Select the point

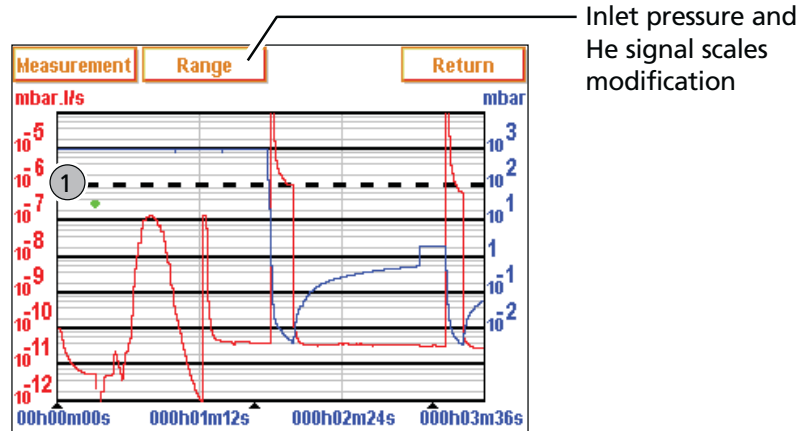

2 - **Measurement**

3 - Exact display of the selected point value

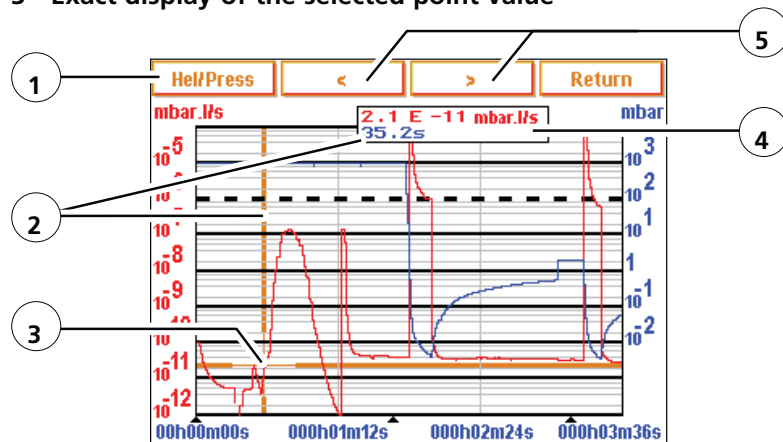

| | |
|---|--|
| 1 | Inlet pressure or He signal display selection |
| 2 | Measure moment regard to recording beginning |
| 3 | Mark indicating the measured point |
| 4 | Tracer gas signal value (in red) or inlet pressure (in blue) display |
| 5 | Navigation between next/previous recorded points |



- To have the exact values of all the recoverable measures under any spreadsheets, save the recorded plotting in .txt file.

Graphic display

Plotting saving

This function allows to save on a SD card the last recorded plotting done for a future reading/analyse on PC.

Saving is not automatic.



It is possible to save a screen copy (.bmp) of the recorded graph or to generate a file (.txt) including the measures done. The .txt file is compatible for any spreadsheets (ex. Excel Microsoft® Office™): the separation by default is "tab".

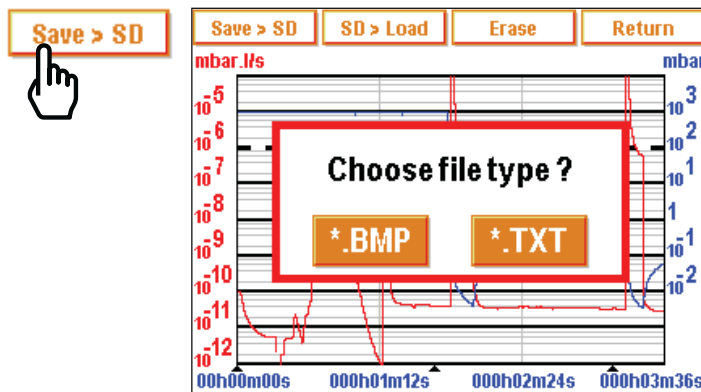

- The .bmp and .txt files saved include only plotting points displayed on the screen:
 - to have all points, it is essential to be on the original plotting (any zoom).
 - if a zoom has been done before the saving, this one will apply only to the points of the selected zone.
- If the saved plotting is constituted by several successive recordings:
 - The cursor "▲" will indicate each recording changes on .bmp files - "B.P. # xx" will be noted at the end of the last plotting of each recording on .txt files.
- .bmp files can be displayed on the control panel screen in the .txt files.
- .txt files can be opened only from a PC.

SD card  C 406

Settings

Purpose

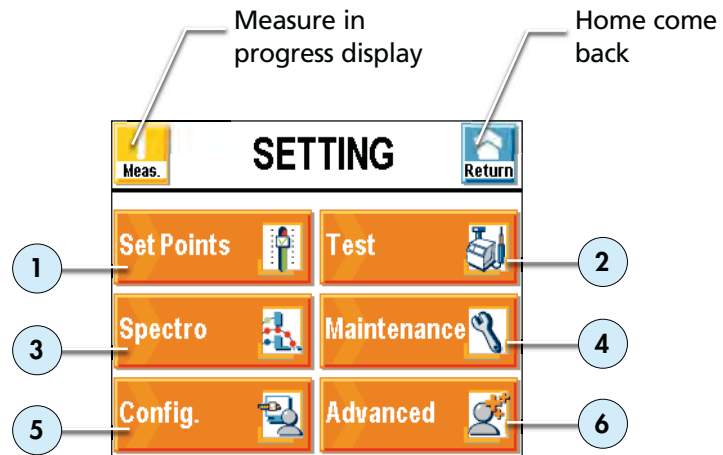











| | | |
|---|--|-------|
| 1 | Set points setting: reject set point, audio level, digital voice, He max. | C 401 |
| 2 | Method and test mode selection. Inlet vent management. Correction value. | C 402 |
| 3 | Tracer gas selection Calibrated leak setting. | C 403 |
| 4 | Maintenance planning. | C 404 |
| 5 | Detector configuration for the user: language, unit, password, function keys, applicative windows. | C 405 |
| 6 | Advanced functions * kept for specific detector uses. It is necessary to read the user's manual. *advanced setting required a good leak detection knowledge: cell setting, pressure gauge, etc. | C 406 |

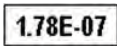

- "Setting" menu is also accesible from any window by pressing simultaneously the leys and .

Settings

Legend

| | |
|---|---|
|  | Deactivated function (OFF) A function can be deactivated without modifying the associated setting. |
|  | Activated function (ON). |
|  | Authorized access without password. |
|  | Locked access : access with password |
|  | Orange key : customizable key or parameters access by tactile press on this key |
|  | White key: key not customizable, for information. |
|  | "Ghost" key: key not accessible (option not available or access only authorized to service centers). |
|  | Measure information key: leak value measured display by tactile press ( C 200). |
|  | Function key: access to function A by tactile press or press on the opposite key  |

Value adjustment from the control panel

Reject Point : 1.0×10^{-07} mbar.lfs

- + x10 Return

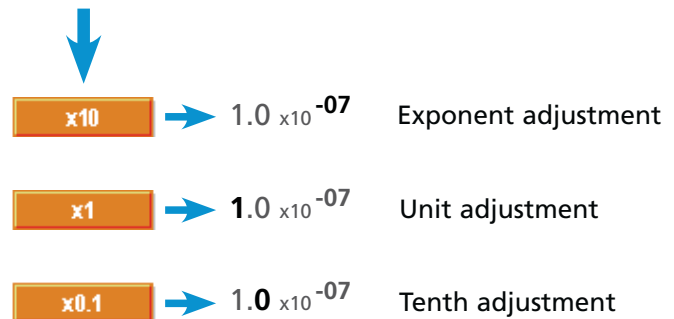

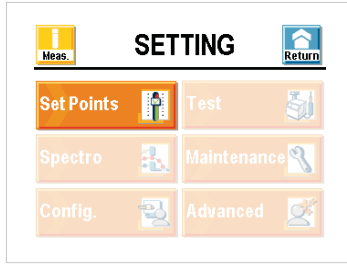

Set points Menu

Purpose Adjustment of the next set points:

- He reject set point (hard vacuum and sniffing)
- audio alarm
- digital voice
- He max.

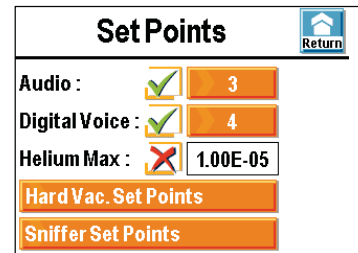

Audio alarm and digital voice set points

Digital voice informs the operator about the detector state or the actions to do.

The audio alarm informs the operator that the reject set point was crossed. The level varies from 0 to 8 (0 to 90 dB).



- Quick access to setting from the control panel:



- Stop simultaneously the audio alarm and the digital voice with the key .

Set points Menu

He max. If the signal quickly increases above He max. set point, the cycle is automatically ended and the leak detector returns to stand-by mode.

On this way, the leak detector is protected from gross contamination by gross leaks.

We recommend that the He max. be set a maximum of 4 decades above the set point.

Prevents the detector from being polluted by helium in hard vacuum test mode.

In case of a high background due to pollution, a simple way to purge the helium from inside the detector is to start a cycle without a blank off on the inlet. The detector stays at atmospheric pressure and creates an internal venting that "pushes" helium outside. Just do that 30 s, 2 or 3 times max, and the level will decrease to around 10^{-8} or 10^{-9} mbar.l/s. To decrease the level further, just let the detector run with the inlet blanked off and in test.



- Very useful function if the part or installation to be tested contains a lot of helium.

Set Points

HardVac. Set Points Return

Reject Point : 1.00E-07

Sniffer Set Points Return

Reject Point : 1.00E-04

Probe Clogged : 1.00E-06

2 adjustable set points:

- reject set point in hard vacuum,
- reject set point in sniffing.

Define the acceptance threshold of the good/bad parts:

- leak value measured \leq reject set point \Rightarrow part accepted
- leak value measured $>$ reject set point \Rightarrow part rejected.



- Fast access to setting from the control panel:

Reject Point

➔

Reject Point :

1.0

$\times 10^{-07}$

mbar.l/s

-

+

$\times 10$

Return

Set points Menu

Probe clogged

| Sniffer Set Points | |  |
|--------------------|----------|--|
| Reject Point : | 1.00E-04 | |
| Probe Clogged : | 1.00E-06 | |

The purpose of this threshold is to check that the sniffer probe is operational.

When the helium signal is lower than the set "probe clogged" reject point, an information will be communicated to the operator to check the probe.

Sniffer probe maintenance  **G 400**



- *Block the sniffer probe end from time to time with a finger to check that the helium signal goes down. If not, the probe may be clogged.*
 - *Do not block the end a long time: if the measured signal decreases too much, there is risk of taking out of the sniffing test.*
-

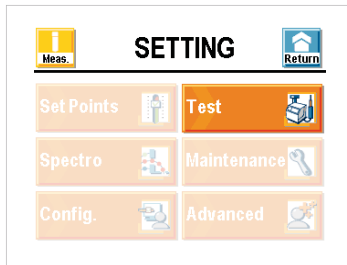

Test Menu

Purpose Adjustment of the next parameters:

- method and test mode
- correction factor
- cycle end
- air inlet

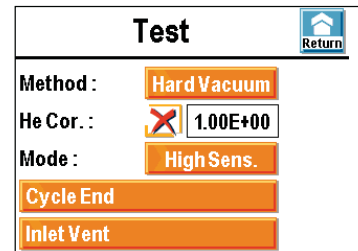

Test methods 2 test methods proposed:

- hard vacuum test
- sniffing test



Hard vacuum test

Make sure that the tested parts can withstand the pressure difference due to the hard vacuum test.





- Quick access to the method choice from the control panel:



Correction factor

The correction factor allows correction of the measured signal by the leak detector when it is in parallel with a pump.

Procedure

- Activate the correction factor function:  or He Cor.: 
- Set the correction factor to apply.

Digital and bargraph display

Only the digital display is corrected by the correction factor. The correction factor does not apply to the bargraph display.

Test Menu



- Use the correction factor to work in a unit other one than those proposed (See board G 700 for the factor to be applied) or with an installation having its own pumping.
- According to the He concentration level in the gas used for the leak detection, the displayed signal changes.
- Example: signal displayed with a calibrated leak of 1×10^{-7} mbar.l/s (with 100 % He) connected to the detector inlet

| % He in the used gas | 100 % | 50 % | 10 % | 1 % |
|---|-----------------------------|-----------------------------|-----------------------------|-----------------------------|
| Displayed signal on the leak detector without COR | 1×10^{-7} mbar.l/s | 5×10^{-8} mbar.l/s | 1×10^{-8} mbar.l/s | 1×10^{-9} mbar.l/s |
| COR value | 1 | 2 | 10 | 100 |
| Displayed signal on the leak detector with COR | 1×10^{-7} mbar.l/s | | | |

- Leak detector calibration with a pumping group E 411.

Test mode

A hard vacuum test can be performed as soon as one of the test modes is reached

The leak detector will automatically switch to the selected mode as soon as the inlet pressure has crossed the threshold.

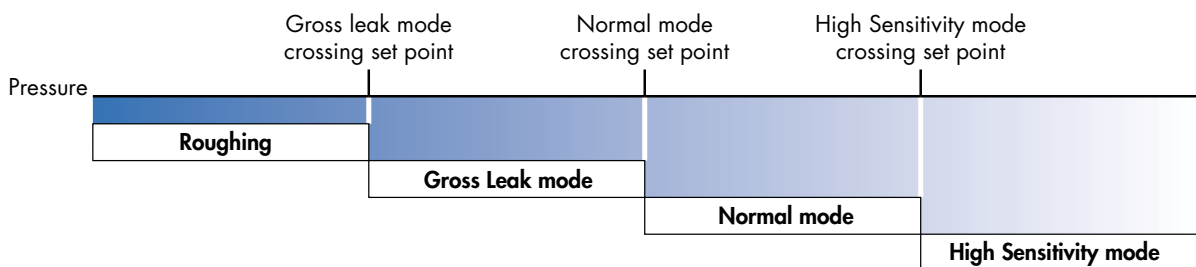

- By default, the leak detector is configured to work in vacuum test, in the most sensitive test mode: this configuration meet the majority of the operators needs.

Test Menu

Cycle end function This function allows an automatic control of the roughing time and measurement time in hard vacuum test.

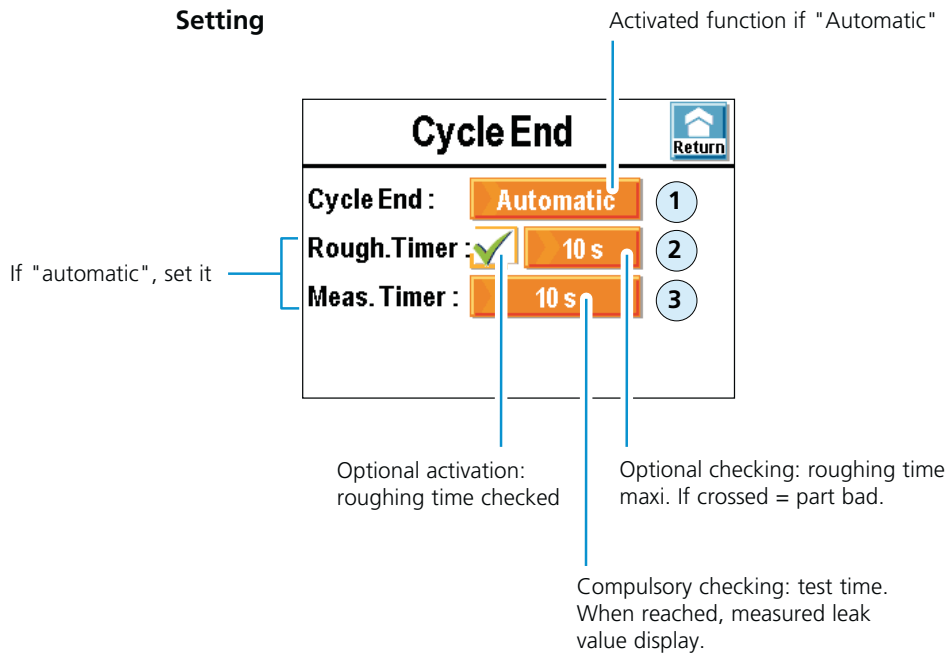

Example ① = Auto ; ② = off ; ③ = 10 sec

- T = 0.....: Cycle start, roughing.
- T = x s: Test pressure reached, measure time counter start (x < 10 s, otherwise part bad).
- T = x + 10 sec.....: Test stop, stand-by mode, inlet vent if automatic



• *Function to use to automate small production or realize repetitive operations with different detectors.*

Test Menu

Air inlet This function allows an automatic air inlet at the end of a test in hard vacuum test.

This function allows to put back to atmospheric pressure the detector inlet and so the part or volume connected.

This function is secure: a confirmation request displays each time that the operator requests an air inlet.

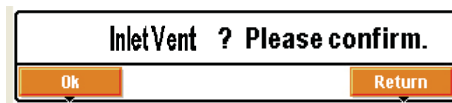

Setting

If "automatic", set it

Inlet Vent Return

Inlet Vent : Operator

Delay : 0 s

Open Timer :
 9 s

Activated function if "Automatic".

Time between the test stop and the valve opening.

Optional automatic closing activation.

Optional automatic closing function
Time between the valve opening and its automatic closing after.

Inlet vent is automatically done when the operator press to stop the test if "Automatic" is selected.

If "Operator" is selected, it is necessary to press the dedicated function key to put back the inlet detector to atmosphere.

Inlet vent manual activation:

From thumb (if parameted) or

From standard window



Test Menu

Air inlet (Cdt)



- To block the air inlet valve command, delete **Inlet Vent** function key (📖 C 405). The icon  will stay in standard screen as indicator but the manual activation by operator will be deactivated.
-

CAUTION

This function can be harmful when the detector is connected to an ultra vacuum or semiconductor or thin film chamber! It is important to not do an inlet vent.

In this case, select "Operator", or / and remove the dedicated function key.

The operator will not have the possibility to do an inlet vent, except with this menu (which can be locked with password 📖 C 405).



- Connect an air inlet vent (or nitrogen) at the inlet vent allows to decrease the He pollution or water pollution of the detector.
 - The automatic closing after a defined time allows to limit the dry air or nitrogen consumption if this one is connected.
 - Always allocate a function key to the inlet vent function to active it manually.
-

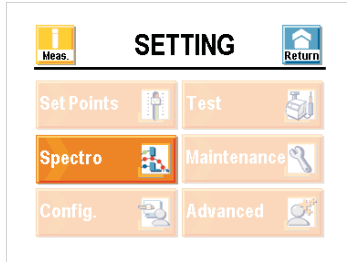

Spectro Menu

Purpose

- Tracer gas selection
- Filament management (switching on/selection)
- Calibrated leak setting

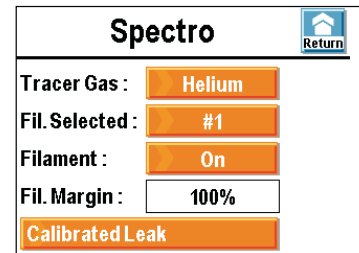

Tracer gas

The tracer gas is the searched gas during a test.
3 gas are proposed: Helium 4, Helium 3 and Hydrogen.

Hydrogen background

Background is much higher in hydrogen.
Typical background values, in cycle, detector on itself:

- at start \pm low range 10^{-5} mbar l/s.
- after 2 or 3 hours \pm low range 10^{-6} mbar l/s.

Test with hydrogen

The 3 masses function purpose, used with hydrogen, is the leak research only and not the continuous analysis of the hydrogen concentration of a gas.
The leak detector is not adapted for a hydrogen concentration continuous analysis. The leak detector use in such conditions, as well as the hydrogen concentration of the gas used, are under the supervision of the user.

Calibration

The leak detector should be calibrated with a calibrated leak of the tracer gas used.

Fil. Margin

It is the global performance indicator of the analyzer cell sensitivity.
Factory departure : Fil. Margin = 100 %
Normal wear on some cell components will reduce this value in the time, without deteriorate the detector measurement accuracy.

Spectro Menu

Calibrated leak

It is necessary to set the calibrated leak used for the autocalibration: use the information indicated on the calibrated leak label or its calibration certificate.

In case of leak change, it is necessary to update these parameters.

- According to the internal or external location selected and tracer gas selected, the parameters displayed correspond to the parameters of the correspondent leak memorized.
- location = internal → the autocalibration will be done with the internal calibrated leak of the leak detector (He leak only).
- location = external → the autocalibration will be done with an external calibrated leak (leak He, ³He or Hy).
- The parameter "Calibration valve" allows to open/close the calibration for a manual calibration for example : this type of calibration is kept to experts. Do not forget to close it back this valve after operation.
- When a parameters saving is realized (📖 C 406), all data of all calibrated leaks set (1 internal and 3 external) are saved.

| CalibratedLeak | | Return |
|----------------|----------|--------|
| Location : | Internal | ↑ |
| Unit : | mbar.l/s | |
| Leak Value : | 1.50E-07 | |
| Carrier Gas : | Helium | |
| Calib. Valve : | Close | ↓ |

| CalibratedLeak | | Return |
|---------------------|---------|--------|
| Loss Per Year (%) : | 6 | ↑ |
| Ref. T° (°C) : | 20 | |
| T° Coeff. (%/°C) : | 3.0 | |
| Year : | 01/2009 | ↓ |

More informations about the calibrated leaks 📖 E 412.

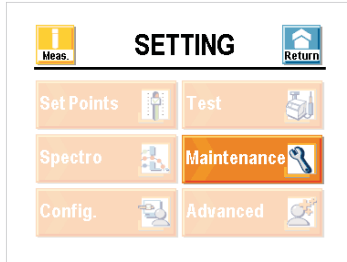

Maintenance Menu

Purpose

Setting of the maintenance follow-up counters:

- primary pump maintenance
- secondary pump maintenance filaments life time
- cycles counter (hard vacuum test)
- general detector counter (under voltage, standby or test).

A message is automatically sent to the operator when the set time is reached to perform a maintenance.

Detector maintenance D and E.

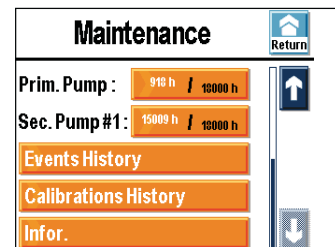
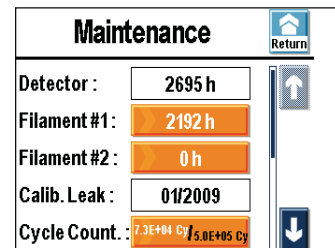

Filament 1-2

Indicates the switching on hours number of the dedicated filament. At each filament exchange, do a counter reset.

Cycles counter

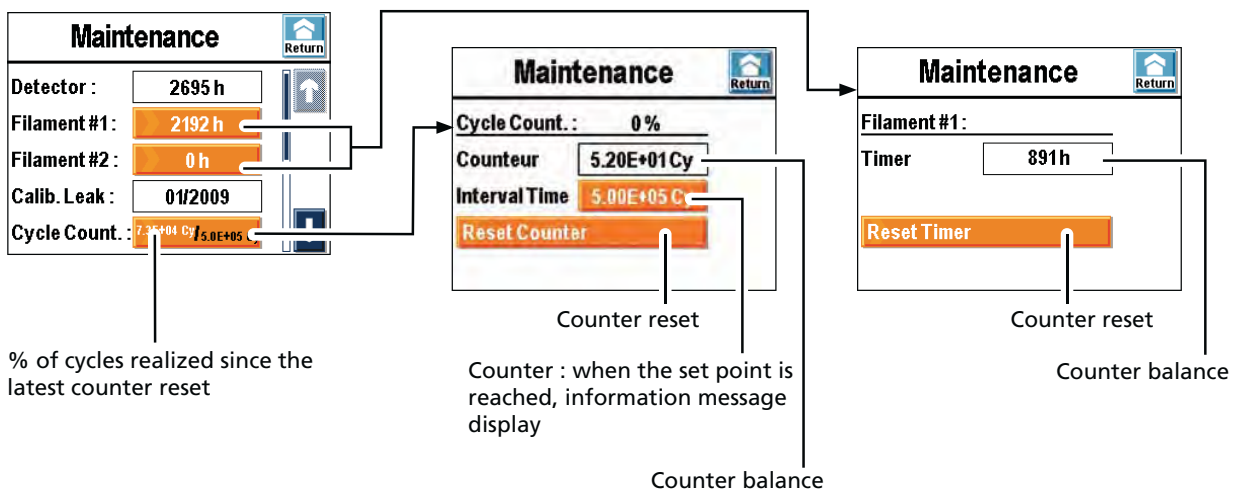

GB 04270 - Edition 02 - March 12



- Do not forget to do a counter reset after having done the maintenance operation.
- According to your need, you can set another value and so better adapt the maintenance to your application.

Maintenance Menu

Primary pump
Secondary pump

| | ASM 380 | ASM 310 |
|-------------------|-------------|-------------|
| Primary pump | ACP 40 | MD1 |
| Secondary pump #1 | ATH 184 HLD | AMH 020 HLD |

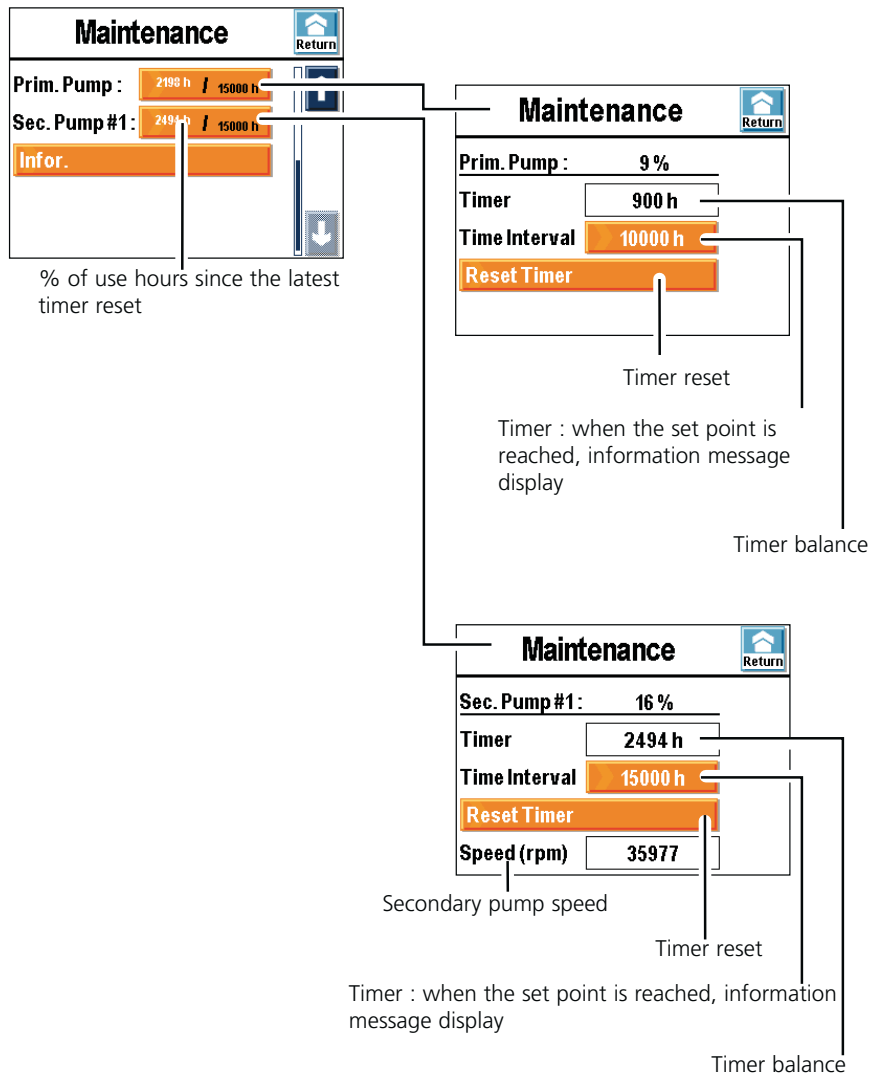

- Do not forget to do a timer reset after having done the maintenance operation.
- With the secondary pump #1 timer, you can follow, for example, the ball bearings maintenance.

Maintenance Menu

Events history

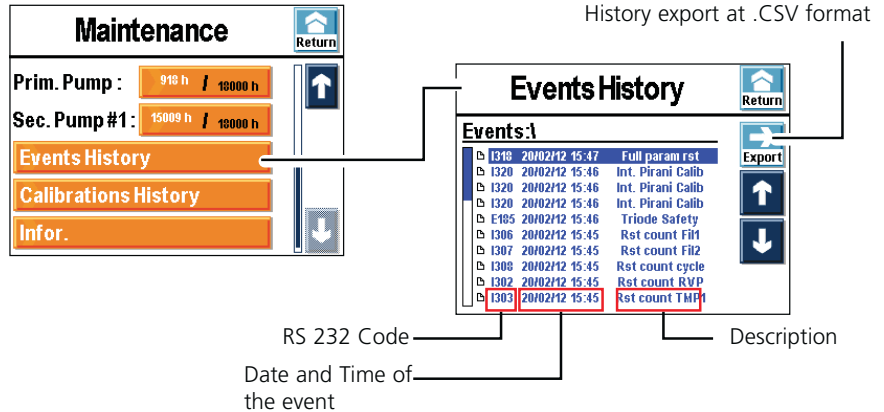

Event = Error (Exxx)
 = Warning (Wxxx)  D 100
 = Event (Ixxx)

Events history records the last 30 events appeared. Beyond 30, the oldest recorded event will be replaced by the last one appeared and so on.

Events list

| Code | Event | Description |
|------|-------------------|---|
| I300 | Air inlet | Air inlet |
| I301 | Stp Cy He>Hemax | Automatic cycle stop if pollution (He signal measured > He max) |
| I302 | Rst count RVP | Primary pump counter reset |
| I303 | Rst count TMP1 | High vacuum pump 1 counter reset |
| I304 | Rst count TMP2 | High vacuum pump 2 counter reset |
| I305 | Rst count TMP3 | High vacuum pump 3 counter reset |
| I306 | Rst count Fil1 | Reset filament 1 counter |
| I307 | Rst count Fil2 | Reset filament 2 counter |
| I308 | Rst count cycle | Reset cycles counter |
| I309 | Ie increase | Automatic Ie increase to 1,5 mA for He/3He or 0,6 mA for Hy |
| I310 | Autocal restart | Automatic autocalibration restart |
| I313 | Date/Time updat | Date or time change |
| I318 | Full param rst | Complete detector parameters reset |
| I319 | Fil change | Filament change (manually or automatically with firmware) |
| I320 | Calib. Pirani int | Automatic internal Pirani gauge calibration |
| I321 | Storage delay | Storage delay : it is activated if the leak detector doesn't start since 15 days (minimum). |

Maintenance Menu

Calibrations history

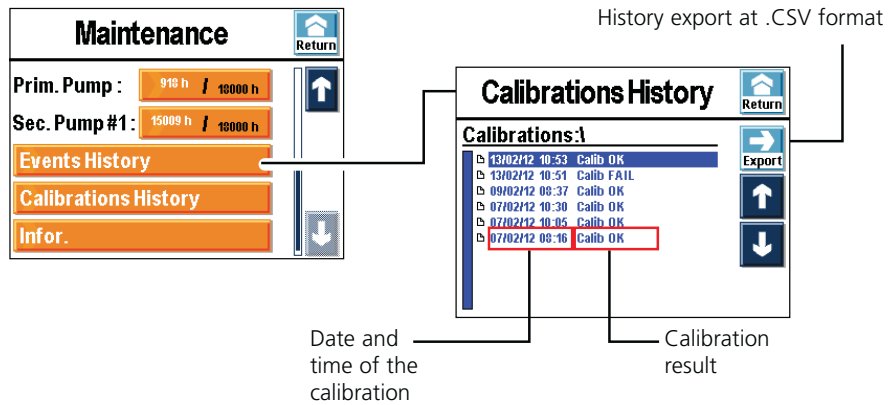

Calibrations history records the last 20 calibrations realized. Beyond 20, the oldest recorded calibration will be replaced by the last one realized and so on.

Infos

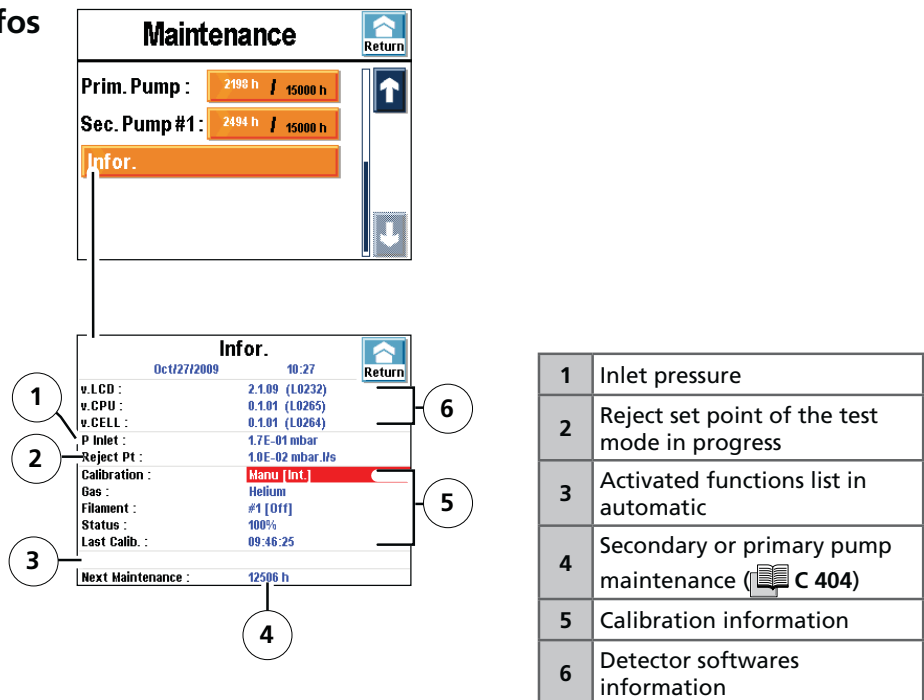

- Quick access to informations from control panel:



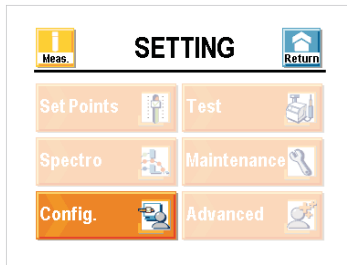

Configuration Menu

Purpose

Setting of the leak detector use parameters:

- hour / date / unit / language,
- function keys (C 200),
- applicative windows,
- screen parameters,
- password management,
- user levels management.

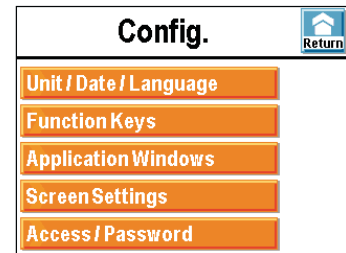

Hour / Date / Unit / Language

The update of these parameters is automatically requested during the first leak detector starting up by the operator: the operator can modify them at any time afterward.

The set points set are not automatically converted in the new unit in case of unit change: the operator must to update them.

The hour is not automatically updated at the passage of the summer time to the winter time and conversely: the operator must to update them

Function keys

The function keys allow to activate/stop a function or to set set points from the different applicative windows.

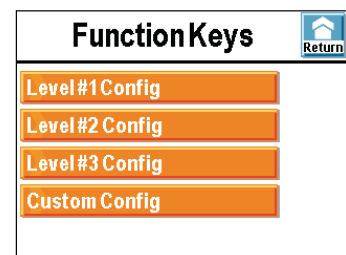

3 configurations are predefined.

The operator can also define its own function keys configuration.

Configuration Menu

Predifined configurations

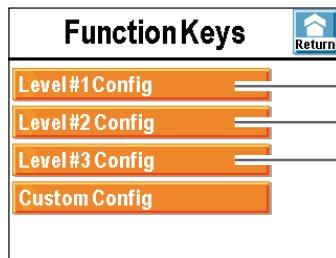

Examples (*)

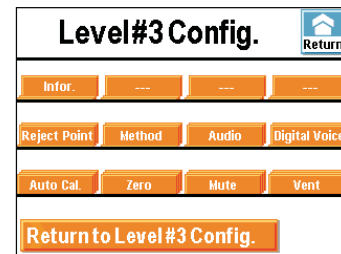
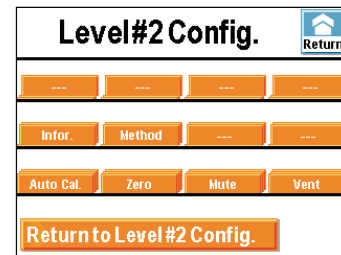
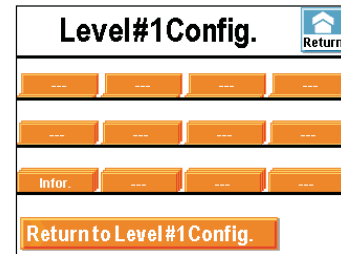

(*) Predifined configurations change according to leak detector model.

Customized configuration

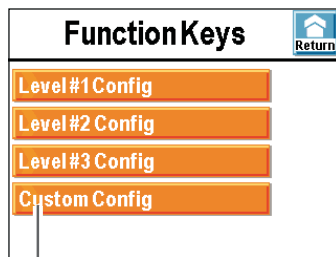

Access to customized configuration.

Each function key can be allocated to a chosen function by the operator: see the example next page.

Thanks to the function keys, it is possible to give to the operator a limited functions access and to protect by password the other notauthorized functions of the "Setting" menu.

Configuration Menu

Example:

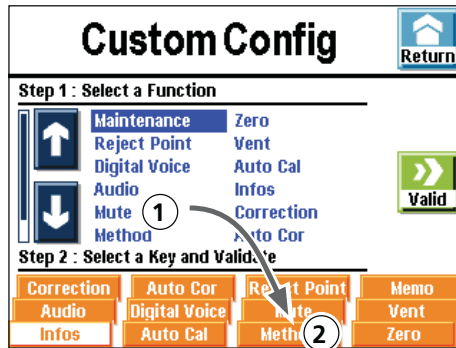

Allocate the "Mute" function ① to the function key ②.

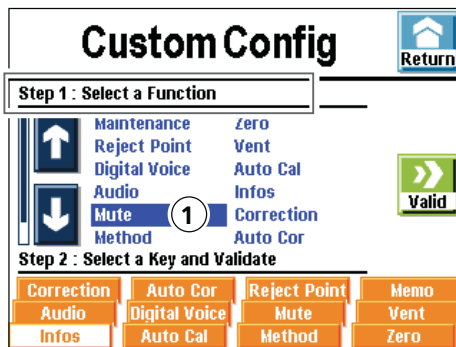

Select the "Mute" function ① with the arrows ↑ and ↓.

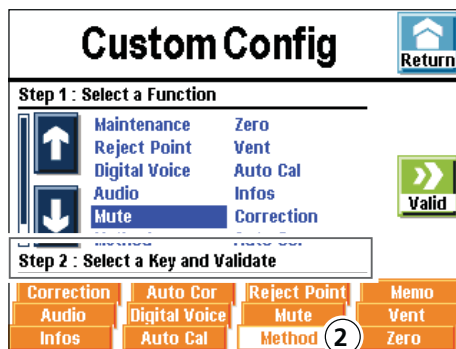

Select the function key ② by successive presses (key selected if white bottom).

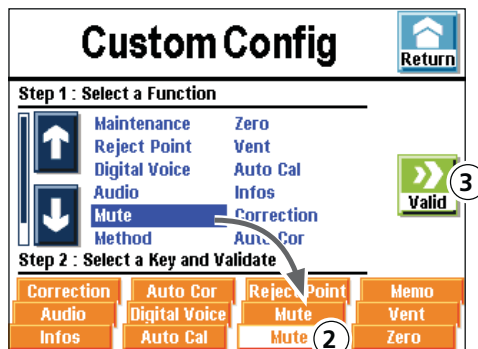

Valid the configuration ③ : the function key ② is now allocated to the "Mute" function.

Configuration Menu

Applicative windows By successive presses on the key , the different applicative windows available appear.

The operator can hide one or several windows or switch around the scrolling order of these.

The standard applicative window is always available:

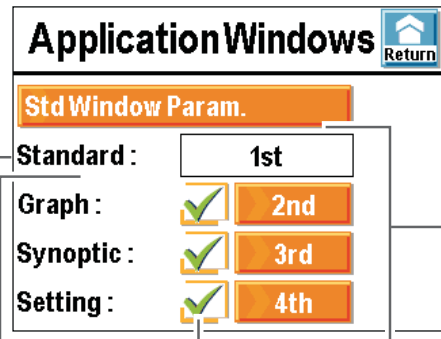

Standard applicative window always available

Windows proposed



Order of the displayed windows with the touch 

Selection of the displayed windows.

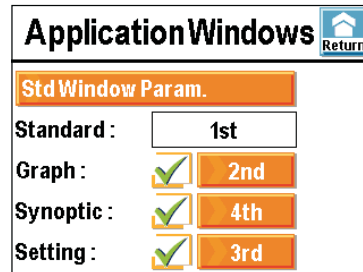
The screenshot shows a menu titled 'Application Windows' with a 'Return' button. Below it is a sub-menu 'Std Window Param.' with four options: 'Standard' (set to '1st'), 'Graph' (checked, '2nd'), 'Synoptic' (checked, '3rd'), and 'Setting' (checked, '4th').



The screenshot shows the same 'Application Windows' menu. The 'Standard' option is still '1st'. The 'Graph' option is checked and '2nd'. The 'Synoptic' option is checked and '4th'. The 'Setting' option is checked and '3rd'.

The window order can be modified: tactile press on the order number and use the keys  and , then validation.

When a window is no more selected ( off) or if its order has been changed, the order is automatically updated.

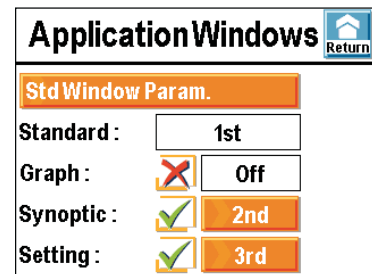

The screenshot shows the 'Application Windows' menu. The 'Standard' option is '1st'. The 'Graph' option is marked with a red 'X' and 'Off'. The 'Synoptic' option is checked and '2nd'. The 'Setting' option is checked and '3rd'.

When a window is again selected, it takes place automatically at the last position.

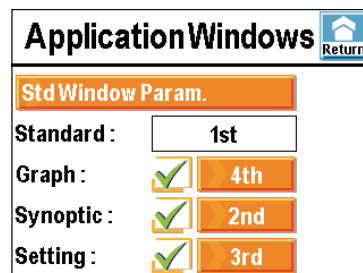

The screenshot shows the 'Application Windows' menu. The 'Standard' option is '1st'. The 'Graph' option is checked and '4th'. The 'Synoptic' option is checked and '2nd'. The 'Setting' option is checked and '3rd'.

Configuration Menu

Standard windows parameters

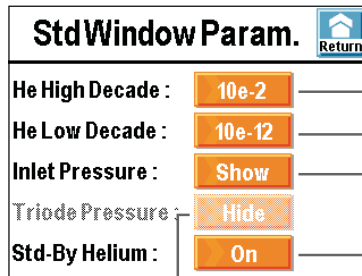

Max decade of the bargraph.
 Mini decade of the bargraph.
 Display/masking of the inlet pressure on the standard display.
 He signal display in stand-by mode.

Screen settings

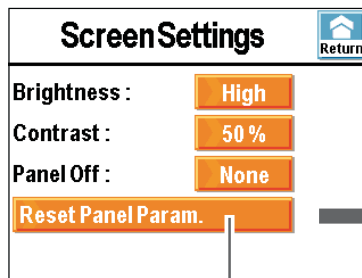

Control panel parameters (= factory leaving configuration (C 500)).

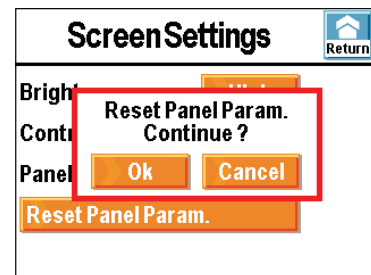

Nota : the screensaver corresponds to the retro-lighting extinction (black screen). The detector seems switched off but it is not the case! A single press on the touch-sensitive screen reactivates the display. By default, the automatic panel off is not activated.

Access password

User levels

3 user levels allow restricting display and access to settings and functions.

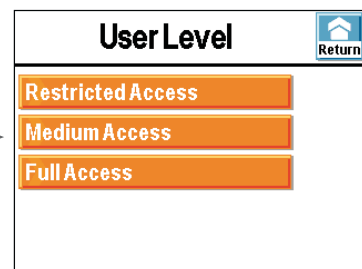
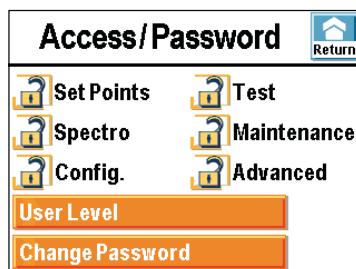





Configuration Menu

To change access level:

- press  an enter password.
-  →  → Change the level.

Restricted Access 

-  key invalid: any setting possible
-  picto invalid
- Function keys hidden
- Inlet pressure and cell pressure hidden
-  key invalid: test start only by RS
- Measured leak value and reject set point displayed only in test
- Access to "Setting" menu by pressing on  for a long time.

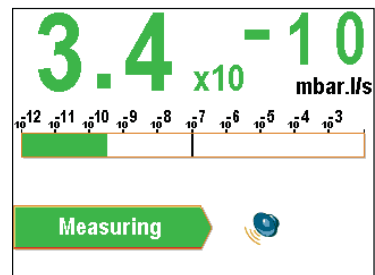
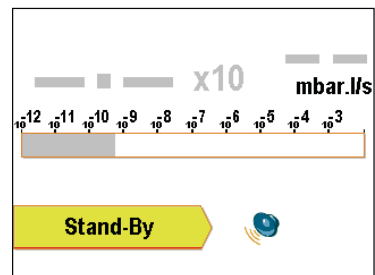

Medium Access 

-  key invalid but access with password: setting possible
- 2 function keys available: « Info » and « Basic param. »
- Cell pressure hidden
- Function keys hidden

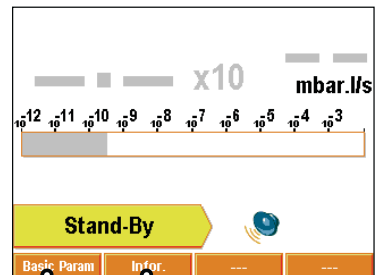



| Basic Param | |  |
|------------------------|-------------------|--|
| Hard Vac. Set Points : | 1.00E-07 mbar.l/s | |
| Sniffer Set Points : | 1.00E-06 mbar.l/s | |
| Method : | Hard Vacuum | |
| Mode : | Normal | |
| Gas : | Helium | |
| P Inlet : | 3.2E+04 mbar | |

| Infor. | |  |
|--------------------|--------------------|---|
| Oct/27/2009 10:27 | | |
| v.LCD : | 2.1.09 (L0232) | |
| v.CPU : | 0.1.01 (L0265) | |
| v.CELL : | 0.1.01 (L0264) | |
| P Inlet : | 1.7E-01 mbar | |
| Reject PT : | 1.0E-02 mbar.l/s | |
| Calibration : | Manu [Int.] | |
| Gas : | Helium | |
| Filament : | #1 [Off] | |
| Status : | 100% | |
| Last Calib. : | 09:46:25 | |
| Next Maintenance : | 12506 h | |

Configuration Menu

Medium Access (ctd) 

- Inlet pressure and cell pressure hidden
-  key valid
- Measured leak value and reject set point displayed only in test.
- Access to "Setting" menu by pressing on  for a long time.

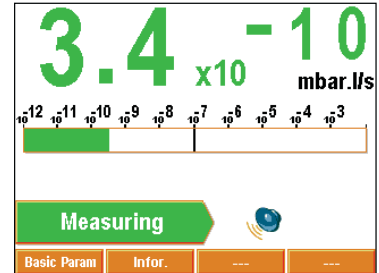

Full Access 

- Any restriction

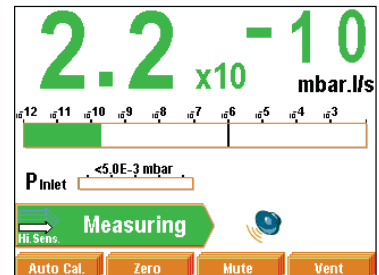
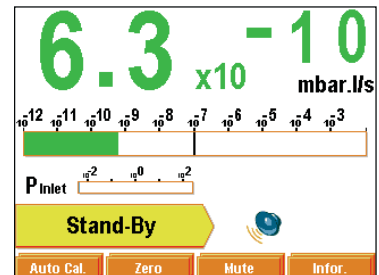

Configuration Menu

"Setting" menu locking The operator can lock the access to one or several setting menus. To access to a locked menu, the password will be ask to the operator.

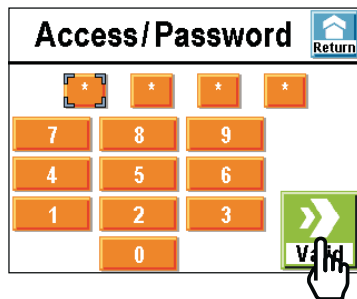

- Enter the password (5555 by default) and validate.
-
- Lock a menu by tactile press on the opened padlock.
-
- To unlock a menu, tactile press on its closed padlock.

■ Example : Locking of Set Points, Spectro and Advanced menus.

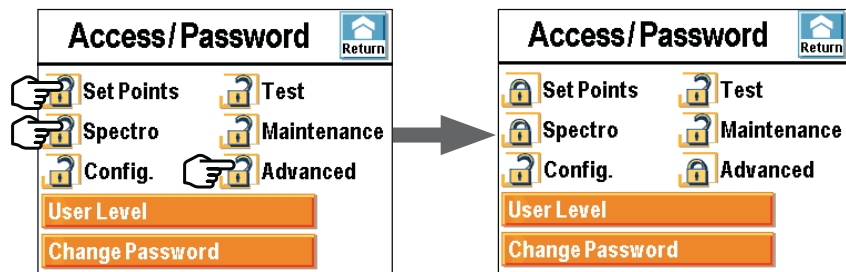

Configuration Menu

In the "Setting" window, the locked menus are indicated with a closed padlock.

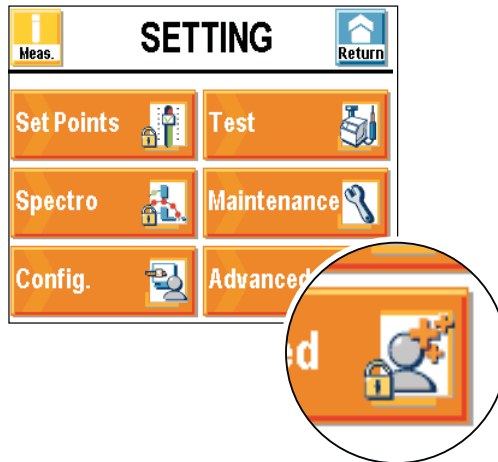

Change password



- Enter the password (5555 by default) and validate.

- Select "Change password": enter the new password and validate.

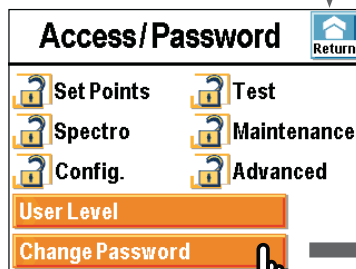

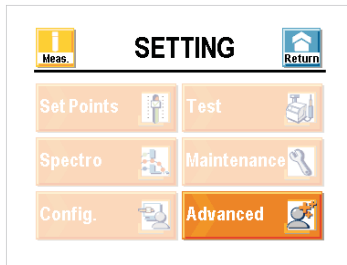

Advanced Menu

Advanced menu is kept to leak detection experts and/or to a particular product configuration.

Purpose Parameters setting connected to:

- advanced functions,
- inputs/outputs,
- SD card (data saving).

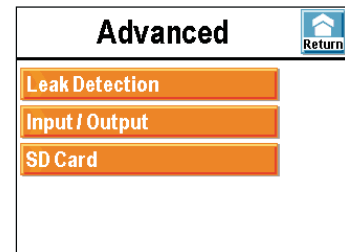

Leak detection menu Setting of the next parameters:

- start-up time delay,
- background suppression,
- zero activation,
- Calibration,
- Memo function.

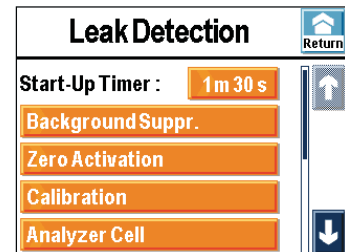

Setting of the next components:

- analyzer cell,
- internal gauge.

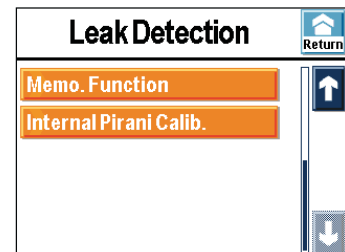

Leak detection: Start-up time delay

This function prevents the leak detector use during a defined time after its switching on. It forbids a measure while the leak detector is neither thermically stabilized, nor degassed.

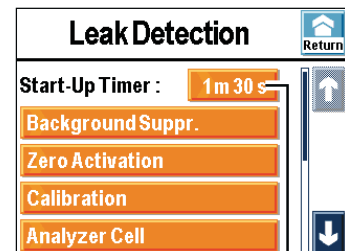

Leak detector locking time

Advanced Menu

Leak detection: Background suppression function

This function allows to remove leak detector internal background.

Note: after autocalibration, background suppression function activated, leak detector background will be at least of $5 \cdot 10^{-12}$ mbar l/s.

Setting

Activated function if "on"

Background Suppr. Return

Activation: **On**



- It is advised to use this function to test very small leaks it improves measurement and reading.
- This function allows to measure a leak flow 2 ranges below the detector background in progress, as soon as this one is no more in roughing.

Leak detection: Zero activation function

This function allows to help the operator to identify very small He signal variations in the surrounding background or to dilate small measured signal fluctuations on the bargraph display, for example at the pump slowing down.

Activated function if "automatic"

If "auto, to set

Zero Activation Return

Activation: **Automatic**

Trigger: **Timer**

Value: **10 s**

Function triggering mode

Function triggering set point

- Manual activation of the Zero function: **Zero**



- It is advised to use this function when the He background is high and stable.
- This function allows to measure a leak flow 2 ranges below the detector background in progress, as soon as this one is no more in roughing.

Advanced Menu

Leak detection: Calibration

It allows to check that the detector is adjusted to detect the selected tracer gas and display a correct leak value.

Generally, to calibrate the leak detector, a calibrated leak is used as reference.

Our leak detectors are equipped with an internal He calibrated leak with reservoir and compensation sensor in temperature.

Setting

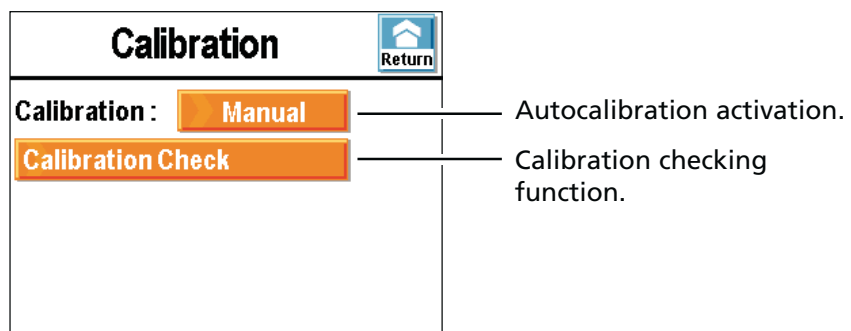

By default, autocalibration is set ON and the internal calibrated leak is selected to allow a quick leak detector autocalibration.

■ Calibration = operator

Calibration must be start by the operator (**Auto Cal.** key) at the leak detector switch on.

If calibration is not realized in the next 20 mn after the leak detector switch on, a reminder message displays.

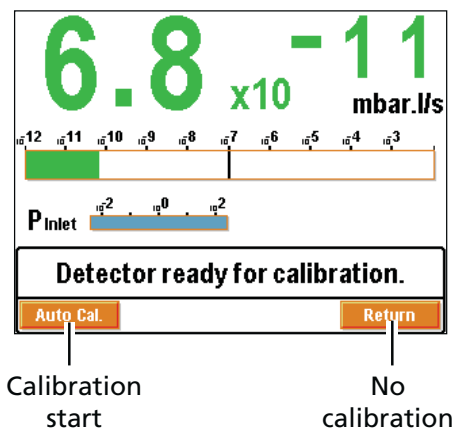

■ Calibration = starting

Calibration is automatically start at the leak detector switch on.

Advanced Menu

- Calibration = manual
Calibration is made manually,
OPERATION RESERVED TO SERVICE CENTERS AND EXPERTS ONLY.
The calibration checking is deactivated.

Other advanced methods It is also possible to do a detector autocalibration with an external calibrated leak  **E 410.**



-
- *It is advised to perform an autocalibration:*
 - *at the detector switching on in order to make sure that it is in correct conditions use*
 - *to optimize the measure reliability for high sensitivity tests*
 - *in case of doubt about the good leak detector functioning (ability to detect correctly a He leak). At any time, an internal calibration can be launched.*
 - *in case of continuous and intensive use: launch an internal calibration at each team beginning (8 hours of work).*
-

Advanced Menu

Calibration checking

If calibration = "operator"/"starting", the function "calibration checking" does a calibration checking according to set parameters.

The calibration checking is deactivated if calibration = "manual".

The calibration checking is done with the internal calibrated leak (location parameter = internal).

The calibration checking function allows to the operator to gain time when a calibration is requested but not necessary because the calibration checking is faster than the complete calibration.

The leak detector compares the internal calibrated leak delivered signal to the calibrated leak parameters memorized:

- If the value is correct, the leak detector calibration is good.
- If the value is out of limits, there is a message which request to start a complete leak detector calibration.

Calibration Checking
Return

Checking : Automatic Function activation.

Every : 50 Cy

Every : 10 h Set points launching the calibration checking. The first reached will launch the checking.



- *At any time, the operator can launch a leak detector calibration checking: detector in stand-by mode, press twice on the function key Auto Cal. in less than 5 secondes.*

Advanced Menu

Leak detection: Analyzer cell

Parameters available in this menu are mainly used for a leak detector manual calibration.

THIS TYPE OF CALIBRATION IS KEPT FOR SERVICE CENTERS.

The image displays two screenshots of the 'Analyzer Cell' menu. The top screenshot shows the following parameters and controls:

- Fil. Selected :** #1 (with an up arrow control)
- Filament :** On (with an up arrow control)
- Triode Pressure :** 0
- Electric Zero :** 684
- Calib. Valve :** Close (with a down arrow control)

The bottom screenshot shows the following parameters and controls:

- Target Value :** 1.89E-07 (with an up arrow control)
- Acc. Voltage (V) :** 140.0
- Emission (mA) :** 0.60
- Sensit. Coeff. :** 1.14E+00
- Int. T° (°C) :** 32 (with a down arrow control)

Annotations with arrows point to specific controls:

- 'Filament selection' points to the up arrow next to 'Fil. Selected'.
- 'Filament switching on.' points to the up arrow next to 'Filament'.
- 'Parameters for manual calibration.' points to the up arrow next to 'Target Value'.
- 'Parameters for manual calibration.' points to the down arrow next to 'Int. T° (°C)'.

Filament There are 2 filaments in the analyzer cell. The operator can select the one or the other one.

The filament can be switched off by the operator (OFF): it is not necessary to switch it off in stand-by mode to save it.



- Do not switch off the filament except to do a manual calibration.
- Attention : the manual calibration is kept to leak detection experts.
- The leak detector swings automatically from a filament to the other one if the selected filament in progress of use becomes defective.
- At the leak detector switching on, the detector will start again with the selected filament at the last switching off.

Advanced Menu

Leak detection: Memo function

This function freezes the screen with the last test result: the measured value displays and flashes.

Setting

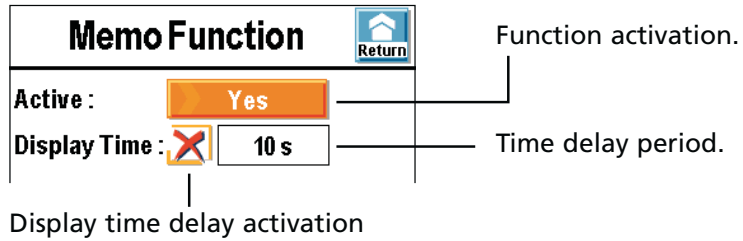

Function activation.

Time delay period.

Display time delay activation

- On : the measured leak value will flash during the time delay period set.
- Off : the measured leak value will flash until a new test will be started.



- Quick access to setting from the control panel:



Advanced Menu

Leak detection: Internal Pirani gauge calibration

This function allows to calibrate the detector internal gauge.



Setting ■ "Cycle end" function = operator  (C 402).

- Close the detector inlet with a blank-off flange. Be sure that the detector is in hard vacuum test and high sensitivity mode( C 404).

- Limit pressure adjustment
Make sure that the internal pressure is widely lower than 10^{-3} mbar.

Start a cycle: press 

The value "Pressure" decreases:
wait the stabilisation of this value
(around 5 minutes) and press on
the key .

- Stop the cycle: press 
Make sure that the detector is at
atmospheric pressure.
The value "Pressure" increases:
wait the stabilisation of this value
(around 5 minutes) and press on
the key .

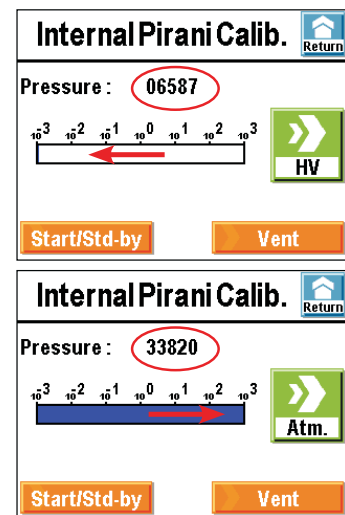

Advanced Menu

Input/Output menu Setting of serial links parameters

- serial link 1: RS 232 (serial)
- serial link 2: Bluetooth

Input/Output: Serial link 1



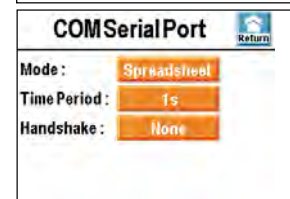
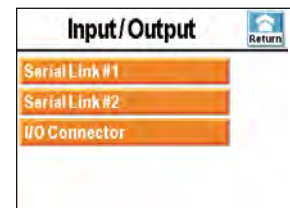



Basic/Spreadsheet/
Advanced modes Connection:  **B 300**



Type User cannot use simultaneously all interfaces: it must allocate one interface at both serial links (1 and 2). Only these interfaces will be active.

Note : It is not necessary to remove the Bluetooth module of the leak detector P0411 supervisor board when it is not allocated to serial link 2.

You can find in table below available interfaces for each serial link.

| | Interface | Serial link 1 | Serial link 2 | Type to select | |
|--|--|-------------------------|---------------|----------------|-----------|
|  B 302 | RS 232 | - | yes | no | Serial |
|  B 308 | Bluetooth ⁽¹⁾ | - | no | yes | Bluetooth |
|  B 304  B 305  B 306 | 37 pins I/O board ⁽¹⁾  B 303 | USB ⁽³⁾ | yes | yes | USB |
| | | Wi-Fi ⁽²⁾ | no | yes | Network |
| | | Ethernet ⁽²⁾ | no | yes | Network |

(1) Option or accessory

(2) Available according to I/O board model

(3) Cannot be allocated to both serial links simultaneously

Advanced Menu

Settings 5 modes are proposed: Basic, Spreadsheet, Advanced, Export Data and RC 500.

| Parameters | |
|-------------|--------------------------------------|
| Mode : | <input type="button" value="Basic"/> |
| Handshake : | <input type="button" value="None"/> |

Basic (standard) It allows continuous data acquisition sent to Hyperterminal (or « ADX Dialog », free adixen software  **G 800**) according to a defined period.

At any time, a command can be sent to leak detector.



- *Recommended mode during leak detector test procedure setting operations.*

Spreadsheet

Spreadsheet mode is a variant of Basic mode.

It allows continuous data acquisition, formatted in a spreadsheet as Excel or other equivalent software..



- *Recommended mode for automatic systems.*

Advanced

Detector is completely controlled by a supervisor (automaton) called “master”. Leak detector is “slave”.

Detector sends information only on the supervisor request.



- *Recommended mode for automatic systems.*

Export Data

It allows exporting, through a PC, test “tickets” issued by leak detector during following operations:

- calibration with an internal/external calibrated leak,
- calibration checking with an internal calibrated leak,
- test.

Serial links 1 and 2 must not be simultaneously in “Export Data” mode.

Export data procedure:  **B 300**.

RC 500

This mode allows working with a wireless remote control (RC 500 WL).

- Installation and use of the RC 500 WL  **C 800**.

Advanced Menu

**Input/Output:
Serial link 2** Same "Serial link 1": refer to this subsection for details.

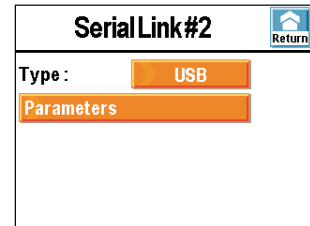

**Input/Output:
I/O connector**

- In standard, the leak detector is equipped with a 15 pin interface. This interface allows essentially recovering the 0/10 V He signal corresponding to leak flow measurement. See B 301.

- In option (A 300) or accessory (A 400), the leak detector can be equipped with a 37 pins I/O interface.

37 pins I/O interface allows controlling leak detector by a programmable automaton or other external automation.



It allows also recovering 0/10 V signal (1 V/decade) corresponding to leak flow measurement.

See B 303.

Advanced Menu

SD card menu

The SD card allows:

- to load leak detector parameters,
- to save leak detector parameters,
- to save recorded test sequences  C 300,
- to visualize .bmp files on the applicative window  C 300.

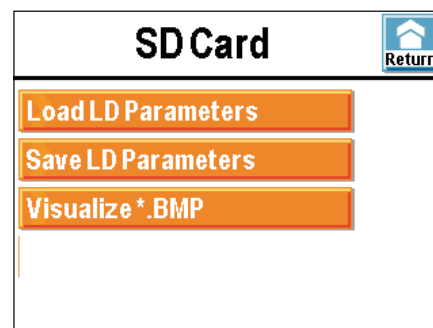

All SD cards in the shop can be used except cards with High Capacity technology, whatever is its capacity. It is necessary to check that the SD card is not locked before its use (message "SD card not detected" displayed).

Load/Save Detec. Param.

The "Load/Save Detec. Param." functions allow to load/save current leak detector parameters, which means factory configuration for parameters not modified ( C 500) and modifications done by the user. You can find below a saving example (leak detector parameters + control panel parameters.)



- If you use the leak detector for several applications, do a configurations library (set parameters) appropriate for every application.
- If you want to configure several detectors in a identical way, use the SD card to save of the one and load on the other one.

Leak detector parameters

Don't take command marked with (*) into account: commands not validated for this product or for R&D only use.

| Command (RS 232 code) | Read value | Parameters command |
|-----------------------------|-------------|--------------------|
| Depollution param. (?AA) | 100-07D | [=AA100-07D] |
| Autocal validation (?AC) | E | [=ACE] |
| ?AC1 (?AC1) (*) | 221-09 | |
| ?AC2 (?AC2) (*) | 372-13 | |
| Automatic Autocal (?ACA) | D0000500010 | [=ACAD0000500010] |
| Value extern HV cal. (?AEH) | 150-09 | [=AEH150-09] |
| Value extern SN cal. (?AES) | 500-08 | [=AES500-08] |
| Analog output1 (?AO1) | 1 | [=AO11] |
| ?AP (?AP) (*) | 300-06E | [=AP300-06E] |
| Autozero status (?AZ) | D | [=AZD] |
| Auto cycle param. (?CA) | DE00100010 | [=CADE00100010] |

Advanced Menu

| Command (RS 232 code) | Read value | Parameters command |
|--------------------------------|--------------------|---------------------------|
| Fil. sens. coeff. (?CF) | 669-03100-02 | [=CF669-031] [=CF100-022] |
| Hours counters val. (?CH) | 004860026400000 | |
| Communication param. (?CO) | 38N2 | |
| ?CP (?CP) (*) | 800-02000+00655+02 | [=CP800-02000+00655+02] |
| Current Det. status (?CY) | HV | |
| Date (?DA) | 112508 | |
| Memorized defaults (?ER) | 0 | |
| RS flow control used (?FC) | 1 | [!NU] |
| Internal calib. leak (?FE) | 140-0936200620 | [=FE140-0936200620] |
| Calib. Leak select (?FEP) | E | [=FEPE] |
| Fil. availability (?FM) | 11 | |
| Tracer gas used (?GZ) | 4 | [=GZ4] |
| ?HT (?HT) (*) | E | [=HTE] |
| HV external coeff. (?HV) | 106-02D | [=HV106-02D] |
| Emission current (?IE) | 059 | [=IE059] |
| Fil1 desired curr. (?IE1) | 060 | |
| Fil2 desired curr. (?IE2) | 060 | |
| Logic input status (?IN) | 00000D | |
| Command (RS 232 code) | Read value | Parameters command |
| He signal calibrated (?LE) | 211-14R | |
| ?LE1 (?LE1) (*) | 320-14 | |
| He signal not cor. (?LE2) | 214-14 | |
| Panel locking status (?LO) | D | |
| Primary pump counter (?MC0) | 0026515000 | [=MC0I15000] |
| HV pump counter (?MC1) | 0026415000 | [=MC1I15000] |
| Rough pump1 counter (?MC2) (*) | 0026400000 | [=MC2I00000] |
| Rough pump2 counter (?MC3) (*) | 0026400000 | [=MC3I00000] |
| Cycle counter (?MCC) | 800-02500+03 | [=MCCI500+03] |
| CPU soft version (?MD) | ASM310L0226V0.0r04 | |
| Memo func. status (?ME) | AD0010000+00 | [=MEAD0010] |
| Logic output status (?OU) | 00000D | |
| GL press. threshold (?P1) | 150-01 | [=P1150-01] |
| Norm. pr. threshold (?P2) | 500-03 | [=P2500-03] |
| HS press. threshold (?P3) | 400-04 | [=P3400-04] |
| Inlet pressure (?PE) | 760+00 | |
| Cell pressure (?PS) | 100-06 | |
| Password (?PW) | 5555D | [=PW5555D] |
| ?RD0 (?RD0) (*) | 02030 | |
| ?RD2 (?RD2) (*) | 005 | [=RD2005] |

Advanced Menu

| Command (RS 232 code) | | Read value | Parameters command |
|------------------------------|-----|-------------------|--------------------|
| ?RD3 (?RD3) | (*) | 019013 | [=RD3019013] |
| ?RD4 (?RD4) | (*) | 000031 | [=RD4000031] |
| ?RD6 (?RD6) | (*) | 1 | [=RD61] |
| ?RD9 (?RD9) | (*) | 000 | |
| ?RDA (?RDA) | (*) | 101597 | [=RDA101597] |
| ?RDB (?RDB) | (*) | 096419 | [=RDB096419] |
| ?RDC (?RDC) | (*) | | [=RDC] |
| ?RDE (?RDE) | (*) | 000 | |
| ?RDF (?RDF) | (*) | 000 | |
| ?RDG (?RDG) | (*) | 000 | |
| Discharge protocol (?AK) | | E | [!NK] |
| Analog output2 (?AO2) | | 2100-14 | [=AO22100-14] |
| ?RDQ (?RDQ) | (*) | 000400 | [=RDQ000400] |
| ?RDK (?RDK) | (*) | 0111D | [=RDK0111D] |
| ?RDT (?RDT) | (*) | 1324823874 | |
| Latest test result (?RE) | | E | |
| RS232mode (?RS) | | 3 | [=RS3] |
| HV signal threshold (?S1H) | | 100-09 | [=S1100-09H] |
| SN signal threshold (?S1S) | | 100-06 | [=S1100-06S] |
| Analyzer cell status (?SC) | | 100 | |
| Sniff.extern coeff (?SN) | | 100-02D | [=SN100-02D] |
| Sound status (?SO) | | 2E | [=SO2E] |
| Language (?SP) | | ANG | [=SP0] |
| ?SR (?SR) | (*) | 0ÿÿÿÿÿÿÿÿ | |
| Detector status (?ST) | | 56642 | |
| Active filament (?SW) | | 1 | [=SW1] |
| Command (RS 232 code) | | Read value | Parameters command |
| Digital voices status (?SY) | | 4D | [=SY4D] |
| Zero ref. status (?SZ) | | 000+00 | |
| HV pump infos (?T1) | | 2 | |
| HV pump more infos (?T1M) | | 0026400 | |
| Rough1 pump infos (?T2) | (*) | S | |
| R.1 pump more infos (?T2M) | (*) | 0026400 | |
| Rough2 pump infos (?T3) | (*) | S | |
| R.2 pump more infos (?T3M) | (*) | 0026400 | |
| Temperature (?TE) | | 28S | [=TE28S] |
| Current hour (?TI) | | 133646 | |
| Latest shut down time (?TIA) | | 090247 | |
| Latest autocal time (?TIC) | | 091844 | |
| Latest start-up time (?TIM) | | 091549 | |
| HLD status (?TR) | | 219-1423874760-02 | |
| Measure unit used (?UN) | | 2 | [=UN2] |

Advanced Menu

| Command (RS 232 code) | Read value | Parameters command |
|--------------------------------|-----------------------|-----------------------------|
| HV pump speed (?V1) | 00003D | |
| Rough1 pimp speed (?V2) | 00003D | |
| ?VA2 (?VA) (*) | 00024 | |
| T. base spreadsheet (?VE) | 000001 | [=VE000001] |
| (?VO) | 135 | |
| (?VO1) | 138 | [=VO1138] |
| (?VO2) | 141 | [=VO2141] |
| (?VT) | A | [=VTA] |
| (?ZE) | 167 | |
| (?ZR) | D | [=ZRD] |
| (?AC3) | 157-10 | |
| (?S1) | 100-09 | [=S1100-09] |
| (?S6) | 100-10 | [=S6100-10] |
| (?WA) | 0 | |
| (?RDO) (*) | 000000000 | |
| (?CYT) | 4 | [=CYT4] |
| (?RJT) (*) | D | |
| (?SHE) (*) | 335-13 | |
| (?PIC) (*) | 00000D100+07100+06 | [=PIC00000D100+07100+06] |
| (?FEM) | 4140-091E302006200628 | [=FEM4140-091E302006200628] |
| (?P4) (*) | 500-03 | [=P4500-03] |
| (?IV) | D | |
| (?IP) (*) | | |
| (?IP0) (*) | 0000 | [=IP0000] |
| (?IP1) (*) | 0000 | [=IP1000] |
| (?IP2) (*) | 0000 | [=IP2000] |
| (?IP3) (*) | 0000 | [=IP3000] |
| (?OP) (*) | | |
| (?OP0) (*) | 0000 | [=OP0000] |
| (?OP1) (*) | 0000 | [=OP1000] |
| (?OP2) (*) | 0000 | [=OP2000] |
| Command (RS 232 code) | Read value | Parameters command |
| (?OP3) (*) | 0000 | [=OP3000] |
| (?OP4) (*) | 0000 | [=OP4000] |
| (?IPG) (*) | AT2573308500584029781 | [=IPG0584029781] |
| EEProm write cycles (?EEP) (*) | 000053025121024 | |
| Test method used (?TST) | 0 | [=TST0] |
| Inlet Vent Param. (?IVP) | A1E0009 | [=IVPA1E0009] |
| Background suppr. (?ZB) | O_0010500-09 | [=ZBO_0010500-09] |
| First detector run (?P3D) (*) | 0 | [=P3D0] |
| (?CRX) (*) | | |

Advanced Menu

| Command (RS 232 code) | Read value | Parameters command |
|---------------------------------|--------------|--------------------|
| (?CES) (*) | 001006 | |
| (?CET) (*) | 0000001 | |
| Checksum detector (?CKS) (*) | 6CD2 | |
| Elec. Zero 0 to 1023 (?ZEL) (*) | 0668 | [=ZE0668] |
| Acc Voltage1/10V (?AVO) (*) | 1355 | [=AVO1355] |
| ?RDR (?RDR) (*) | 000110 | [=RDR000110] |
| ?CPI (?CPI) (*) | | |
| ?PPI (?PPI) (*) | | |
| ?NPI (?NPI) (*) | 049 | |
| Filament defaults (?FMD) (*) | 00 | |
| Cell soft. version (?VSC) (*) | L0227V1.0r02 | |
| Characteriz. Vacc (?CCR) (*) | 02206 | [=CCR2102206] |
| Characteriz. Vacc (?CCR) (*) | 01495 | [=CCR3101495] |
| Characteriz. Vacc (?CCR) (*) | 01134 | [=CCR4101134] |
| Characteriz. Vacc (?CCR) (*) | 02236 | [=CCR2202236] |
| Characteriz. Vacc (?CCR) (*) | 01515 | [=CCR3201515] |
| Characteriz. Vacc (?CCR) (*) | 01146 | [=CCR4201146] |
| Checksum (?CHK) (*) | 00006CD2 | |
| MASSIVE Mode (?MAS) (*) | | |

Control panel parameters Don't take commands marked with (*) into account: commands not validated for this product or for R&D only use.

| Command (RS 232 code) | Read value | Parameters command |
|--------------------------|-------------|--------------------|
| Panel soft version (*) | 001.002.010 | [>VER001.002.010] |
| View curve type (*) | 003 | [>TCO003] |
| Graph window time (*) | 001 | [>WIT001] |
| Graph sampling time (*) | 002 | [>SAT002] |
| High helium decade (*) | -04 | [>DHH-04] |
| Low helium decade (*) | -11 | [>DHB-11] |
| Low bargraph decade (*) | -12 | [>DBB-12] |
| High bargraph decade (*) | -02 | [>DBH-02] |
| High pressure decade (*) | 003 | [>DPH003] |
| Low pressure decade (*) | -03 | [>DPB-03] |
| View reject point? (*) | 000 | [>REP000] |
| Hardkeys#1 (*) | 009000000 | [>HK0009000000] |
| Hardkeys#2 (*) | 007000000 | [>HK1007000000] |
| Hardkeys#3 (*) | 005000000 | [>HK2005000000] |
| Hardkeys#4 (*) | 008000000 | [>HK3008000000] |
| Hardkeys#5 (*) | 002000000 | [>HK4002000000] |

Advanced Menu

| Command (RS 232 code) | | Read value | Parameters command |
|-----------------------|-----|------------|--------------------|
| Hardkeys#6 | (*) | 001000000 | [>HK5001000000] |
| Hardkeys#7 | (*) | 004000000 | [>HK6004000000] |
| Hardkeys#8 | (*) | 003000000 | [>HK7003000000] |
| Hardkeys#9 | (*) | 010000000 | [>HK8010000000] |
| Hardkeys#10 | (*) | 012000000 | [>HK9012000000] |
| Hardkeys#11 | (*) | 012000000 | [>H10012000000] |
| Hardkeys#12 | (*) | 012000000 | [>H11012000000] |
| Luminosity setting | (*) | 254 | [>LUM254] |
| Ecran#0 | (*) | 001 | [>EC0001] |
| Ecran#1 | (*) | 002 | [>EC1002] |
| Ecran#2 | (*) | 003 | [>EC2003] |
| Ecran#3 | (*) | 004 | [>EC3004] |
| Panel contrast | (*) | 00000 | [>COP00000] |
| Panel off after | (*) | 000 | [>MVE000] |
| First screen display | (*) | 001 | [>APR001] |

Factory configuration of the leak detector parameters

Parameters configuration



The following list indicates the factory configuration of the leak detector parameters.

When the leak detector is switched off, all set parameters are memorized and values are kept for the next start-up.

We advise you to note in the "Customer modification" column, the parameter values modified for your application.

The operator can save and load different leak detection configurations. For that, use the functions "Save LD parameters" in the "SD card" advanced menu ( C 406).



The saved values are the set values at the saving moment.

| | Parameters | Configuration |
|--|----------------------------|---------------|
| | | Factory |
|   C 401 | Vacuum reject point | 1.0E-07 |
| | Sniffing reject point | 1.0E-04 |
| | Probe clogged reject point | 1.1E-06 |
| | Alarm | 3 - On |
| | Digital voice | 4 - On |
| | He Max. | Off |
| | He Max. reject point | 1.0E-05 |







Factory configuration of the leak detector parameters

| | Parameters | Configuration |
|---|--|---|
| | | Factory |
| <div style="background-color: #f4a460; padding: 5px; display: flex; align-items: center;"> Test </div> <p style="text-align: center; margin-top: 10px;"> C 402 </p> | Method | Vacuum |
| | Mode | High sensitivity |
| | Hard vacuum correction | off |
| | Hard vacuum correction value | 1.00E+00 |
| | Sniffing correction | off |
| | Sniffing correction value | 1.0E+00 |
| | Cycle end | Operator |
| | Roughing time activated | yes |
| | Roughing time | 00:10 |
| | Measure time | 00:10 |
| | Inlet vent | Operator |
| | Delay | 0 s |
| | Time activation | off |
| | Time | 9 s |
| <div style="background-color: #f4a460; padding: 5px; display: flex; align-items: center;"> Spectro </div> <p style="text-align: center; margin-top: 10px;"> C 403 </p> | Tracer gas | He |
| | Location | Internal |
| | Calibration valve | Closed |
| | Internal calibrated leak value | See the calibration certificate of the internal calibrated leak delivered with the detector |
| | Calibration year | |
| | Unit | |
| | Loss per year (%/yr) | |
| | T° Coeff. (%/°C) : | |
| Ref. T° | | |
| <div style="background-color: #f4a460; padding: 5px; display: flex; align-items: center;"> Maintenance </div> <p style="text-align: center; margin-top: 10px;"> C 404 </p> | Primary pump maintenance counter initial value | 18000 |
| | Secondary pump maintenance counter initial value | 18000 |
| | Cycles maintenance counter initial value | 5.00E+05 |

Factory configuration of the leak detector parameters

| Parameters | Configuration | |
|--|--|--------------------|
| | Factory | |
| <div style="border: 1px solid black; padding: 5px; margin-bottom: 10px;">   </div> | Language | |
| | Unit | |
| | Date | |
| | Time | |
| | Password | 5555 |
| | Function keys | config. Level 3 |
| | Graph application screen selected | yes |
| | Vacuum circuit application screen selected | yes |
| | Setting application screen selected | yes |
| | He high decade | 1.0E-2 |
| | He low decade | 1.0E-12 |
| | Inlet pressure | Show |
| | Triode pressure | Hide |
| | Stand-by He | On |
| | Screen luminosity | high |
| | Screen contrast | 50 % |
| | Panel off | off |
| | Set points menu access | yes |
| | Test menu access | yes |
| | Spectro menu access | yes |
| Maintenance menu access | yes | |
| Config. menu access | yes | |
| Advanced menu access | yes | |

Factory configuration of the leak detector parameters



| Parameters | Configuration | |
|---|----------------------------------|---|
| | Factory | |
| Memo function activated | off | |
| Display timer activated | no | |
| Timer (mm:ss) | 00:10 | |
| Background suppression | on | |
| Zero activation | operator | |
| Trigger | timer | |
| Value | 5.0E-07 | |
| Timer (mm:ss) | 00:10 | |
| Autocalibration | manual | |
| Cal. check | manual | |
| Every (cycles) | 0050 | |
| Every (hours) | 0010 | |
| Filament used | 1 | |
| Mode | advanced | |
| Period | 1 s | |
| Handshake | no | |
| Analog output # 1 (9 – ground) ⁽¹⁾ | Mantissa | |
| Analog output # 2 (10 – ground) ⁽¹⁾ | Logarithmic (10 ⁻¹²) | |
| I/O configuration ⁽²⁾ | Config # 2 | |
| Analog output # 1 (37 – ground) ⁽²⁾ | Mantissa | |
| Analog output # 2 (36 – ground) ⁽²⁾ | Logarithmic | |
| Analog output # 3 (19 – ground) ⁽²⁾ | Exponent | |
| Digital input # 1 (11 – ground) ⁽²⁾ | Calibration |  |
| Digital input # 2 (30 – ground) ⁽²⁾ | HV Test |  |
| Digital input # 3 (12 – ground) ⁽²⁾ | Filament |  |
| Digital input # 4 (31 – ground) ⁽²⁾ | GL Mode |  |
| Digital input # 5 (13 – ground) ⁽²⁾ | Sniffer test |  |
| Digital input # 6 (32 – ground) ⁽²⁾ | Inlet test |  |
| Digital Transistor output # 1 (9 – 28) ⁽²⁾ | Filament on |  |

Advanced



 C 406

Factory configuration of the leak detector parameters

| | Parameters | Configuration | |
|--|---|-----------------|-----------|
| | | | Factory |
| <div style="background-color: #f4a460; padding: 5px; display: inline-block; text-align: center;"> Advanced  </div>  C 406 | Digital Transistor output # 2 (8 – 27) ⁽²⁾ | None | NC |
| | Digital Transistor output # 3 (7 – 26) ⁽²⁾ | None | NC |
| | Digital Transistor output # 4 (6 – 25) ⁽²⁾ | None | NO |
| | Digital Relay output # 5 (5 – 24) ⁽²⁾ | Sniffing test | NO |
| | Digital Relay output # 6 (4 – 23) ⁽²⁾ | GL Test | NC |
| | Digital Relay output # 7 (3 - 22) ⁽²⁾ | HS Test | NC |
| | Digital Relay output # 8 (2 – 21) ⁽²⁾ | HV Test | NC |
| | Digital Relay output # 9 (1 – 20) ⁽²⁾ | He reject point | NO |

(1) 15 pin interface

(2) 37 pin I/O interface (option/accessory)

«Setting» menus arborescence

Nota: Values given for example

Set Points

Set Points

Audio : 3

Digital Voice : 4

Helium Max : 1.00E-05

Hard Vac. Set Points

Sniffer Set Points

Hard Vac. Set Points

Reject Point : 1.00E-07

Sniffer Set Points

Reject Point : 1.00E-04

Probe Clogged : 1.00E-06

Test

Test

Method : Hard Vacuum

He Cor. : 1.00E+00

Mode : High Sens.

Cycle End

Inlet Vent

Cycle End

Cycle End : Automatic

Rough.Timer : 10 s

Meas. Timer : 10 s

Inlet Vent

Inlet Vent : Operator

Delay : 0 s

Open Timer : 9 s

Spectro

Spectro

Tracer Gas : Helium

Fil. Selected : #1

Filament : On

Fil. Status : 100%

Calibrated Leak

CalibratedLeak

Location : Internal

Unit : mbar.L/s

Leak Value : 1.50E-07

Carrier Gas : Helium

Calib. Valve : Close

Calibrated Leak

Loss Per Year (%) : 6

Ref. T° (°C) : 20

T° Coeff. (%/°C) : 3.0

Year : 01/2009

GB 03294 - Edition 03 - March 12

«Setting» menus arborescence

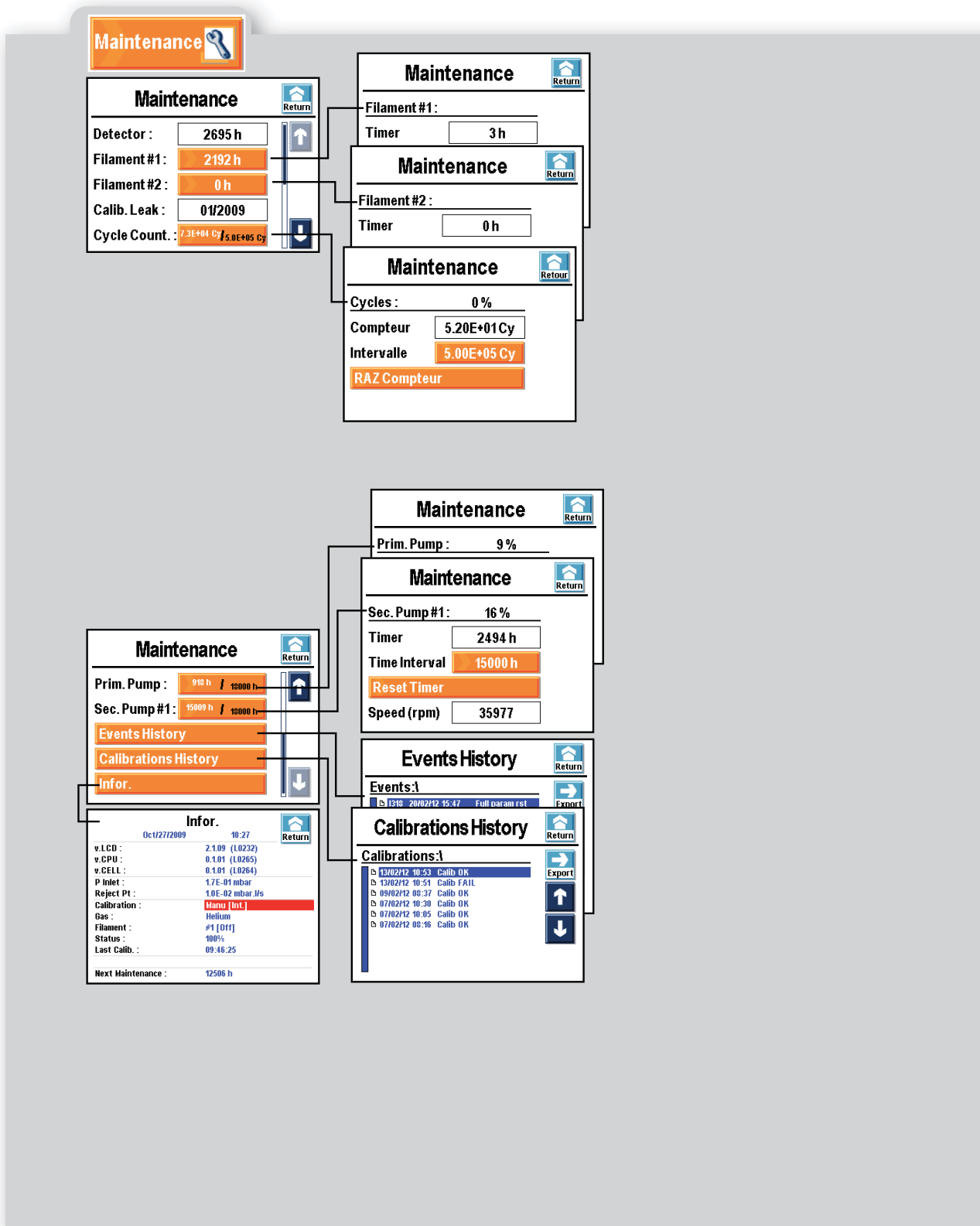

«Setting» menus arborescence

Nota: Values given for example

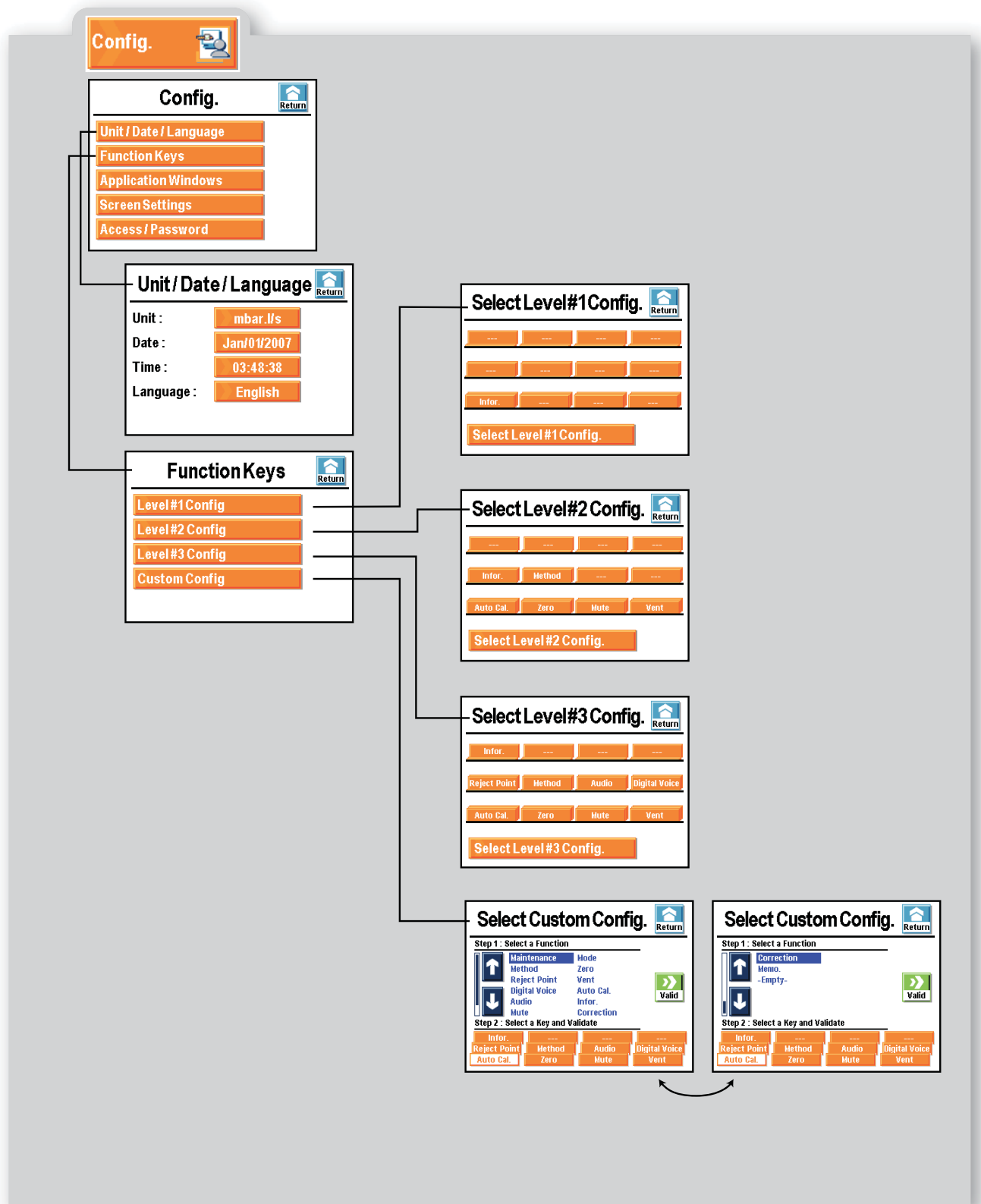

«Setting» menus arborescence

Nota: Values given for example

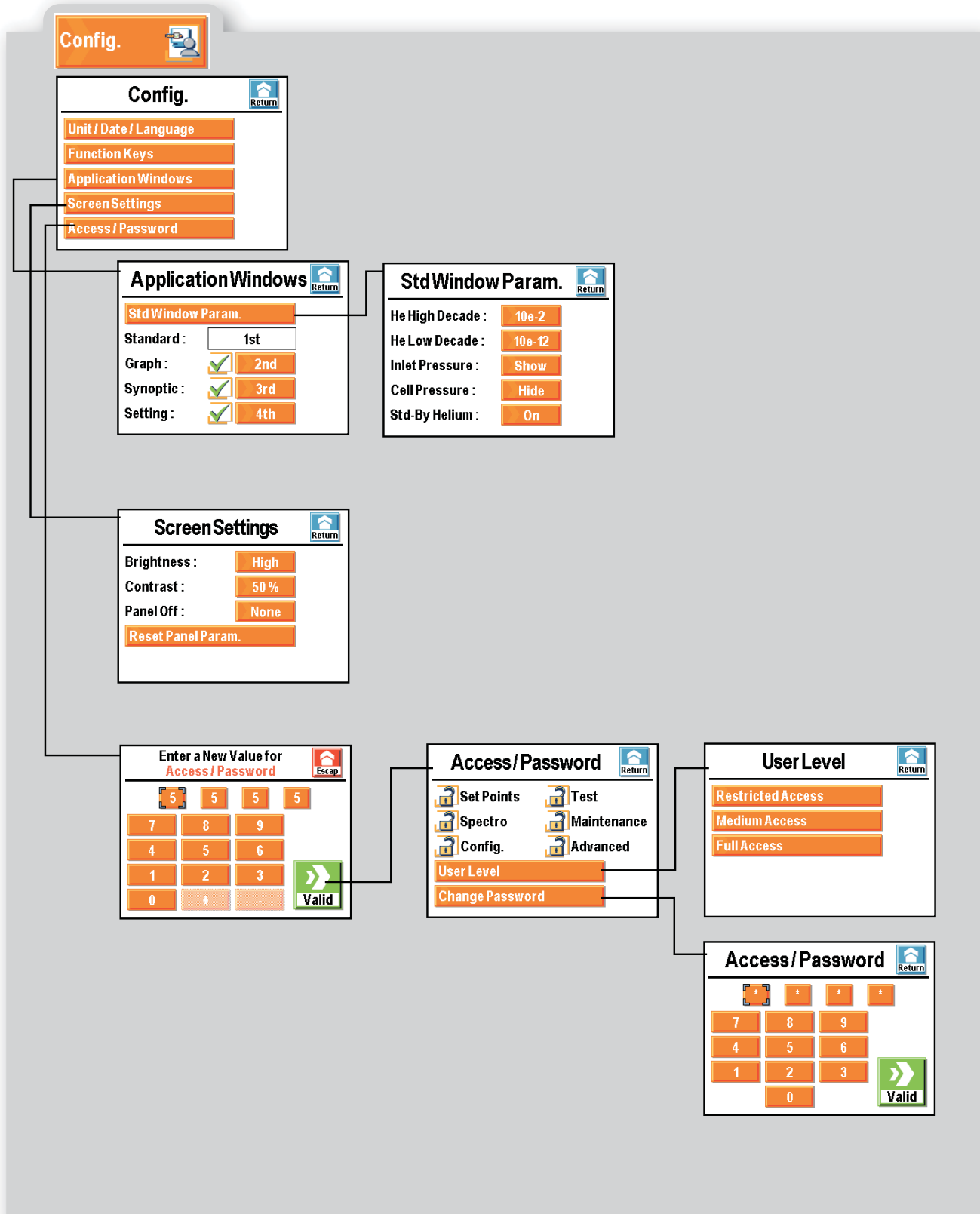

«Setting» menus arborescence

Nota: Values given for example
 (*) Adjustable only if calibration = operator

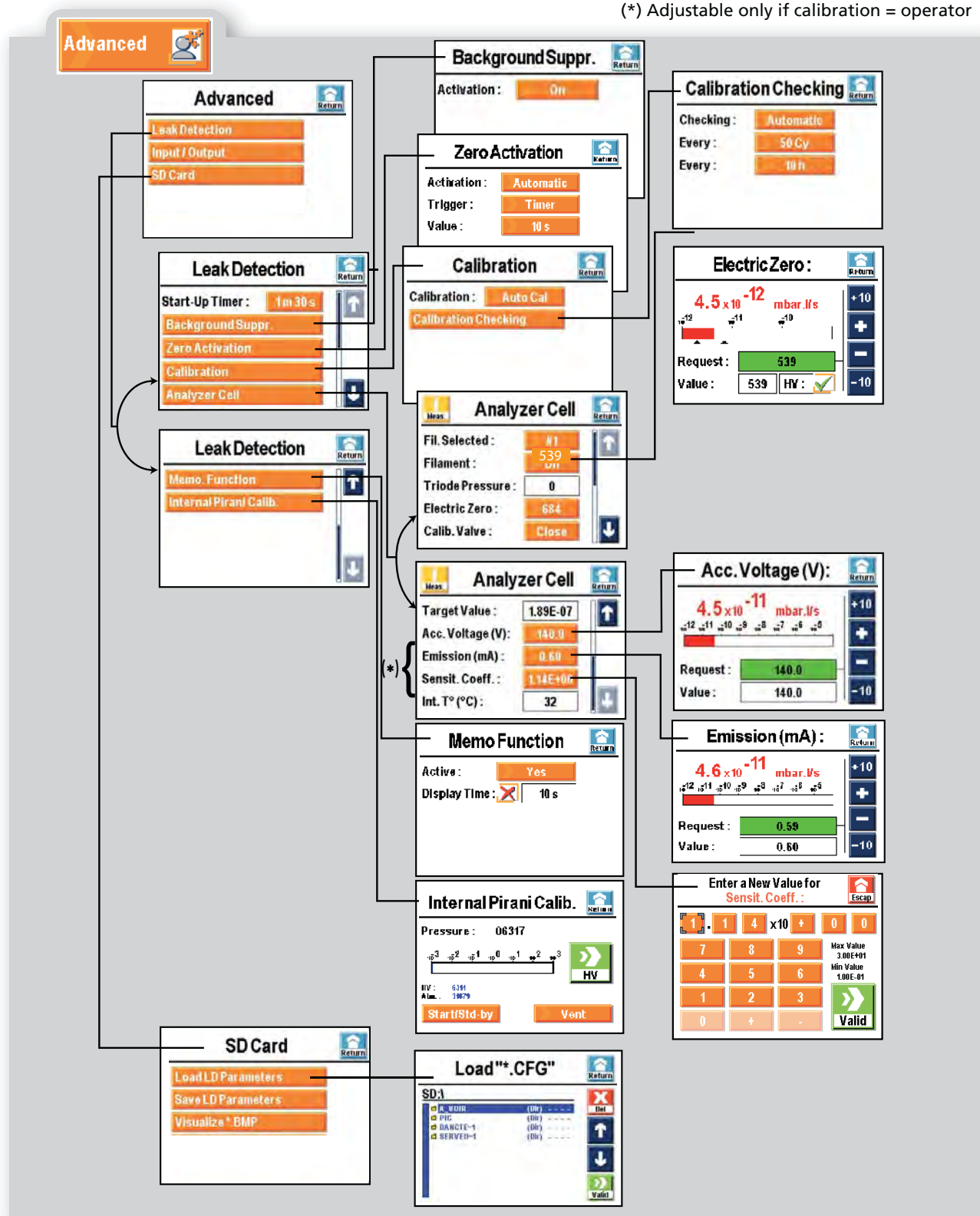

«Setting» menus arborescence

Nota: Values given for example

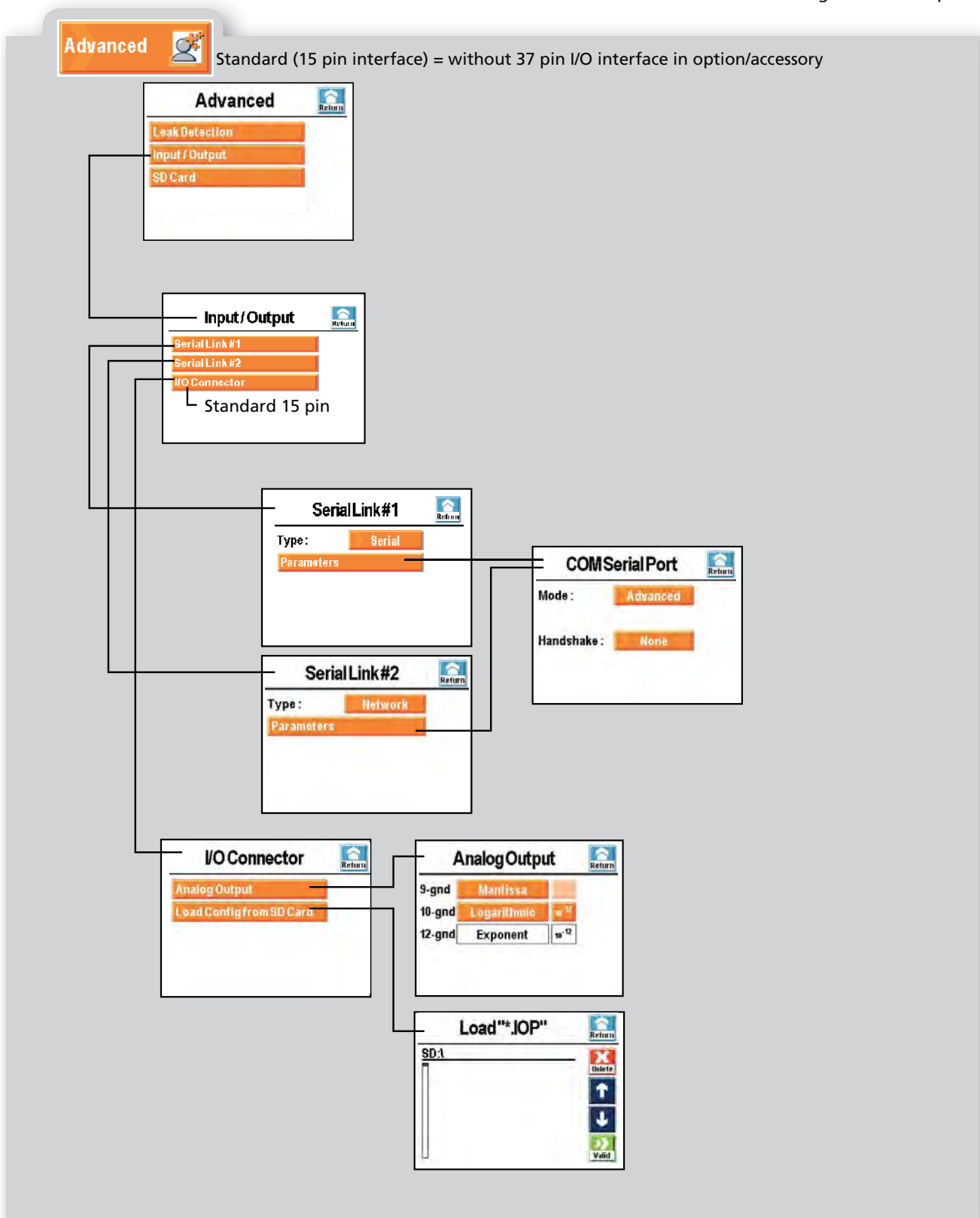

«Setting» menus arborescence

Nota: Values given for example

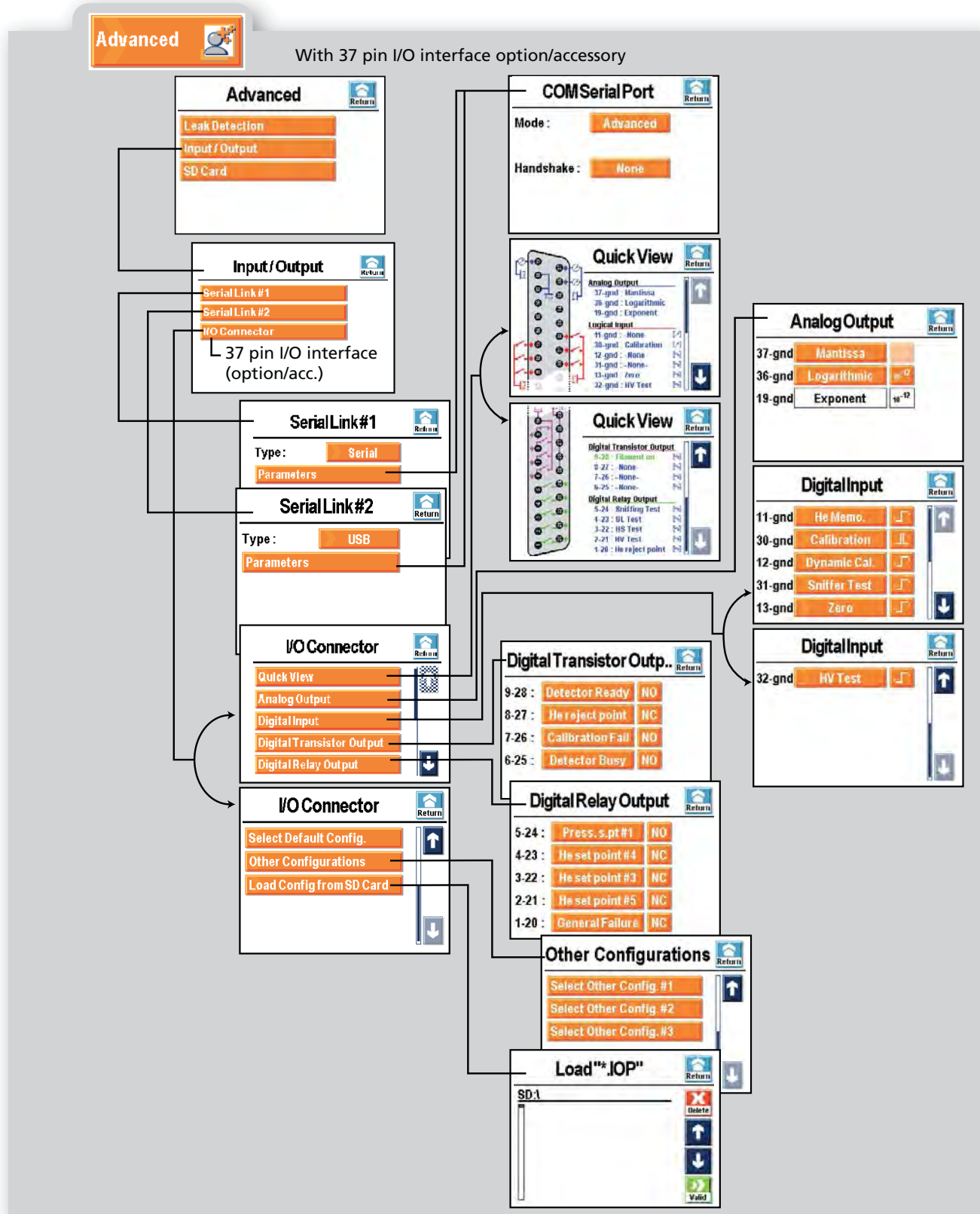

Remote control (accessory)



The remote control is equipped with magnets allowing the operator to place it on a metallic surface. The operator can read the helium signal and has access to control keys such as cycle command, autocalibration and auto-zero.

Interface

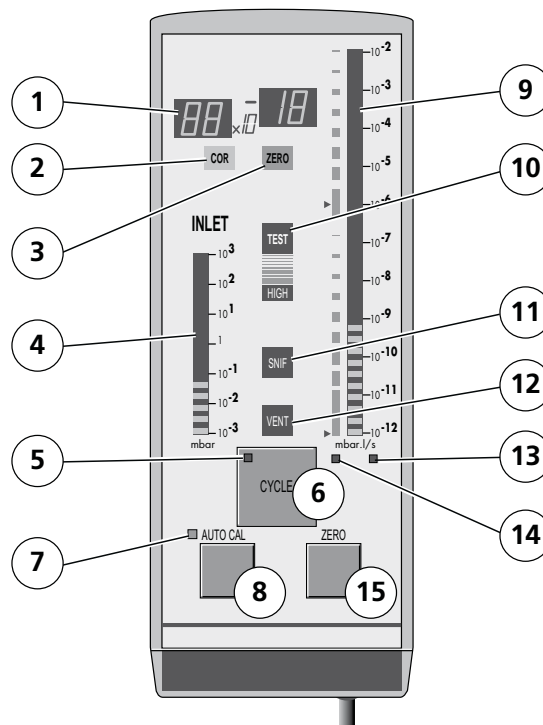

| | | | |
|---|--|----|---|
| 1 | Helium Signal digital display | 8 | Auto-calibration Start/Stop control key |
| 2 | Correction factor COR indicator | 9 | Helium signal analog display |
| 3 | Zero function indicator | 10 | Test ON indicator |
| 4 | Inlet port pressure analog display | 11 | Sniffing test mode ON indicator |
| 5 | Test ON indicator (ON when activated) | 12 | Inlet VENT ON indicator |
| 6 | Test Start/Stand-by control key | 13 | Helium signal standard scale ON indicator |
| 7 | Calibration in progress indicator | 14 | Helium signal Zero scale ON indicator |
| | | 15 | Zero ON/OFF control key |

Remote control (accessory)

Connecting

 B 210

Choice 3 different units can be selected in the leak detector but only one unit is available on the remote control.
So the operator should choose the remote control according to of the operation unit chosen.

Units  C 405

Accessories  A 400

When the operator connects the remote control to the leak detector, the leak detector unit is automatically reprogrammed with the unit of the remote control. The remote control unit is memorized by the detector when the operator disconnects the remote control.

Use and display

The remote control:

- displays the leak rate value,
- controls the start/stop cycle, zero function and internal calibration,
- displays the status of the air inlet vent, sniffing test mode and external calibration,
- does not allow to adjust leak detector parameters.

Analog and digital displays

On the remote control and control panel, the displayed values on the analog and digital displays are exactly the same.

To start/stop a cycle



In order to start/stop a cycle, operator can use either the control key on the control panel or remote control.



Display

The LED indicator is ON/OFF when the control key is activated/deactivated: if the led is OFF, the leak detector is in stand-by.
As soon as the detector is in test, the TEST indicator is ON.

Remote control (accessory)

Use and display (ctd)

Zero function

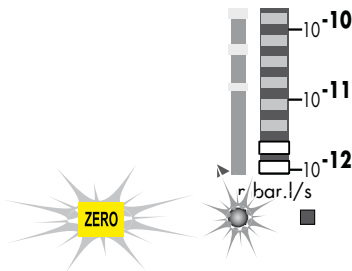

In order to start the zero function, operator can use the ZERO control key on either the control panel or the remote control.

Display

Two indicators are ON when the zero function is activated:

- the ZERO indicator,
- the zero scale indicator.

Zero function C 406

Autocalibration



In order to start an internal auto-calibration, the operator can use the AUTO CAL function key on either the control panel or the remote control.

Display

The LED indicator is ON when the control key is activated.

The LED indicator is OFF at the end of the calibration procedure.

Calibration of the leak detector C 406

Inlet vent Sniffing test mode



For these 2 functions, the remote control displays only their status: use

the control panel in order to activate/deactivate them. C 402

Display

The LED indicator is ON/OFF when the function is activated/deactivated.

External calibration



The remote control displays only its status: use the control panel in order to start/stop it.

Display

The LED indicator is blinking when the external calibration is activated.

At the end of the calibration procedure, the LED indicator is OFF and the correction factor COR is ON.

External calibration E 410

Wireless remote control (accessory)



With the RC 500 WL wireless remote control, the user can start a test, activate the ZERO function and display measured signal value. The calibration cannot be start from the remote control: it can be start only from the leak detector. User can also record and save test data.

RC 500 WL wireless remote control is equipped with magnets allowing placing it on any metallic surface.

Supplies

- RC 500 WL wireless remote control
- Wall plug-in power supply (for integrated battery)
- Radio transmitter (Bluetooth)

Other supplies not used with adixen leak detectors:

- 4 m connection cable
- Connection cable for radio transmitter
- Operating instructions: this manual refers to SmartTest HLT 5xx leak detectors. Specific instructions for ASM xxx leak detectors are included in this sheet.

Technical characteristics

- Dimensions (L x W x H) 210 x 90 x 46 mm
- Weight 0.5 kg
- Display TFT ¼ VGA 3.5
240 x 320 px, erreur max. 4 px
- Protection (remote control closed) IP 42
- Audio alarm (at 1 m) 70 db(A) max.
- Headphone plug Jack 3.5 mm ; > 2 x 32 Ω
- Frequency of wireless transmission 2.4 GHz
- Range of wireless transmission (in the best reception conditions)
 - > 100 m in free field with external radio transmitter
 - 10 m in free field with a leak detector equipped with internal Bluetooth (in option/accessory).
- Charging voltage from wall plug-in power supply 24 V DC, max. 0.7 A
- Battery operation time (with full battery level) 8 hours
- Internal memory capacity 64 MB ; 32 MB of which is available for recording data

Wireless remote control (accessory)

Remote control presentation

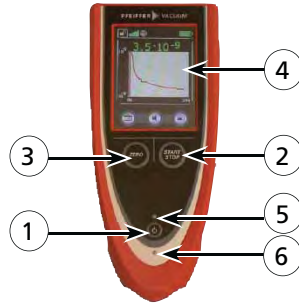

| POS. | DESCRIPTION |
|------|---------------------------|
| ① | Remote control Start/Stop |
| ② | Test Start/Stop |
| ③ | Zero function |
| ④ | Touch display |
| ⑤ | Operating led |
| ⑥ | Charge led |

| | |
|---------------------------|--|
| Remote control Start/Stop | <ul style="list-style-type: none"> • Switch on the remote control pressing briefly on the button. • Switch off the remote control pressing at least 2 s on the button. |
| Test Start/Stop | <ul style="list-style-type: none"> • Pressing the button starts the leak test. • Pressing the button again stops the test. |
| Zero function | <ul style="list-style-type: none"> • Pressing the button activates the Zero function. • Pressing the button again deactivates the Zero function. |
| Touch display | <ul style="list-style-type: none"> • Displays digital or graphic results of realized measurements. • Gives diverse leak detector status. • Offers operating interfaces. |
| Operating led | <ul style="list-style-type: none"> • Remote control switched on, led is turned on and flashed on and off when the remote control is ready for use. |
| Charge led | <ul style="list-style-type: none"> • Led is turned on while the battery is being charged. |

Wireless remote control (accessory)

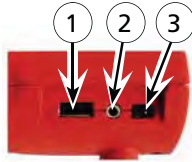

| POS. | DESCRIPTION |
|------|--------------------------------|
| ① | USB connection |
| ② | 3.5 mm jack plug |
| ③ | Wall plug-in power supply plug |

Connection USB

- Insert a USB stick (FAT formatted) to record data

3.5 mm jack plug

- Allows connecting stereo headphones with 3.5 mm jack plug and > 2 x 32 Ohm impedance.
- If headphones are connected, integrated loudspeaker volume is automatically lowered.

Wall plug-in power supply



Delivered with the remote control, it allows charging the remote control integrated battery.

While the battery charges:

- Remote control is always switched on and can be used.
- Charge led is turned on: it is turned off as soon as the battery is completely charged.
- Press briefly «Start/Stop» button reduces the display backlight intensity.

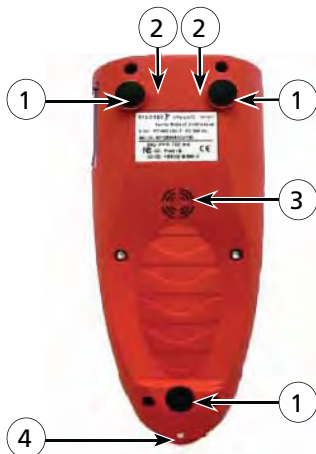

| POS. | DESCRIPTION |
|------|--|
| ① | Magnets |
| ② | M3 threaded bushings for screws with max 6 mm length |
| ③ | Outlet for the integrated loudspeaker |
| ④ | Eye for attaching carrying devices |

Wireless remote control (accessory)

Operation display Lightly pressing on the button/symbol with a finger or a blunt pen allows accessing to functions available on the display.

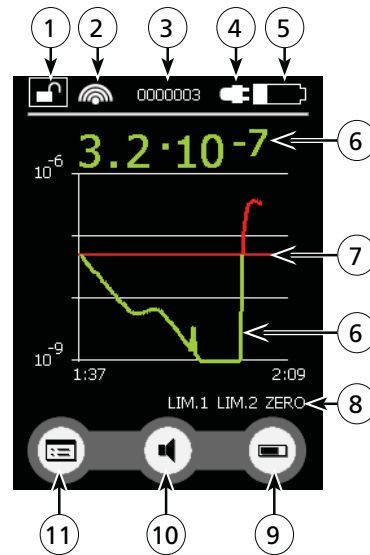

| POS. | DESCRIPTION |
|------|--|
| ① | Lock/Unlock button Press 2 s the button allows locking all the operation display. Button then becomes dark. To unlock display, press again 2 s the button. |
| ② | Wireless connection status Indicates if the remote control is connected to a leak detector with a wireless connection. |
| ③ | Number of the current data record |
| ④ | Battery charge in progress |
| ⑤ | Battery charge level |
| ⑥ | Measured values display |
| ⑦ | Reject point set in the remote control |
| ⑧ | LIM.1/LIM.2: indicates that reject point set in the leak detector has been crossed. ZERO: indicates that Zero function is activated |
| ⑨ | Toggle display of measured values Allows a large digital display of the values or a display according to time (graph) |
| ⑩ | Audio level Allows adjusting the audio level of the leak detector loudspeaker and the remote control loudspeaker |
| ⑪ | Access to main menu |

Wireless remote control (accessory)

Main menu

Access: press .

Allows setting remote control parameters.

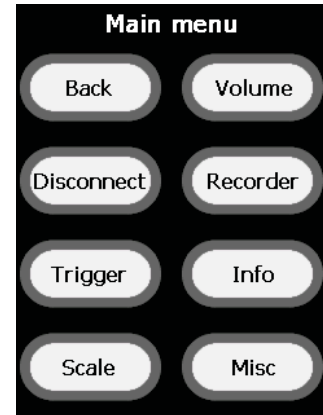

| | |
|-----------------------------|---|
| Back | Back to operation display |
| Connect / Disconnect | Search for a receiver (radio transmitter) connected to a leak detector. |
| Trigger | Remote control reject point setting (mantissa and exponent) |
| Scale | Scales setting for graph and bargraph |
| Volume | Audio level setting for leak detector and remote control |
| Recorder | Measurements recording Copy and delete recorded data files |
| Info | Other information about battery, wireless connection and current software version |
| Misc | Setting of the language, time, date and display backlight |

Basic functions



| | |
|-----------|--|
| ? | Open a help window for the current display. <ul style="list-style-type: none"> • Press «?». • Use the arrows to scroll through longer texts. • Close the window with «OK» |
| X | Close the current page. <ul style="list-style-type: none"> • No changes made will be saved. |
| OK | Close the current page. <ul style="list-style-type: none"> • Changes made will be saved. • Remote control will work now with these new settings. |

Wireless remote control (accessory)

Connect / Disconnect Search for a receiver (radio transmitter) connected to a leak detector.



If no connection is found within 20 s in the receiver field, search is aborted.

If devices with which a connection is possible are found in the field, they are displayed in the connectable devices list.

Select the desired device and connect it pressing «Connect» button. The main menu opens automatically.



Press «Cancel» button to end the connection process and return to the main menu.

«Connect» button is displayed in the main menu as long as there is not a connection with a leak detector. After connection, button changes to «Disconnect». When user closes an existing connection with «Disconnect» button, main menu is displayed.

Trigger Remote control reject point setting (mantissa and exponent)



Each field to set can be selected with buttons ◀ and ▶.

The selected field is marked red and can be changed. Use the numeric keypad to enter the desired digit.

Confirm the set level with «OK».

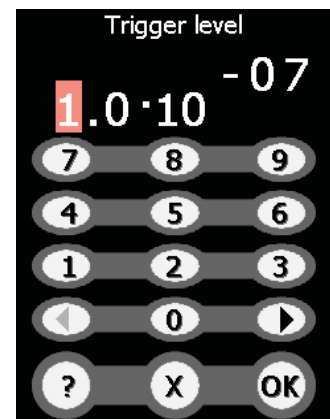

Wireless remote control (accessory)

Reject point set in the remote control (6a) does not correspond to the reject set point set in the leak detector: it is only the reject point set in the remote control which causes the remote control audio alarm start.

However, when the reject set point set in the leak detector is crossed, «LIM.1/LIM.2» (6b) message displays.

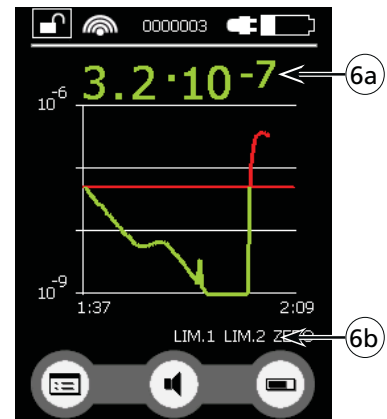

Wireless remote control (accessory)

Scale Scales setting for graph and bargraph

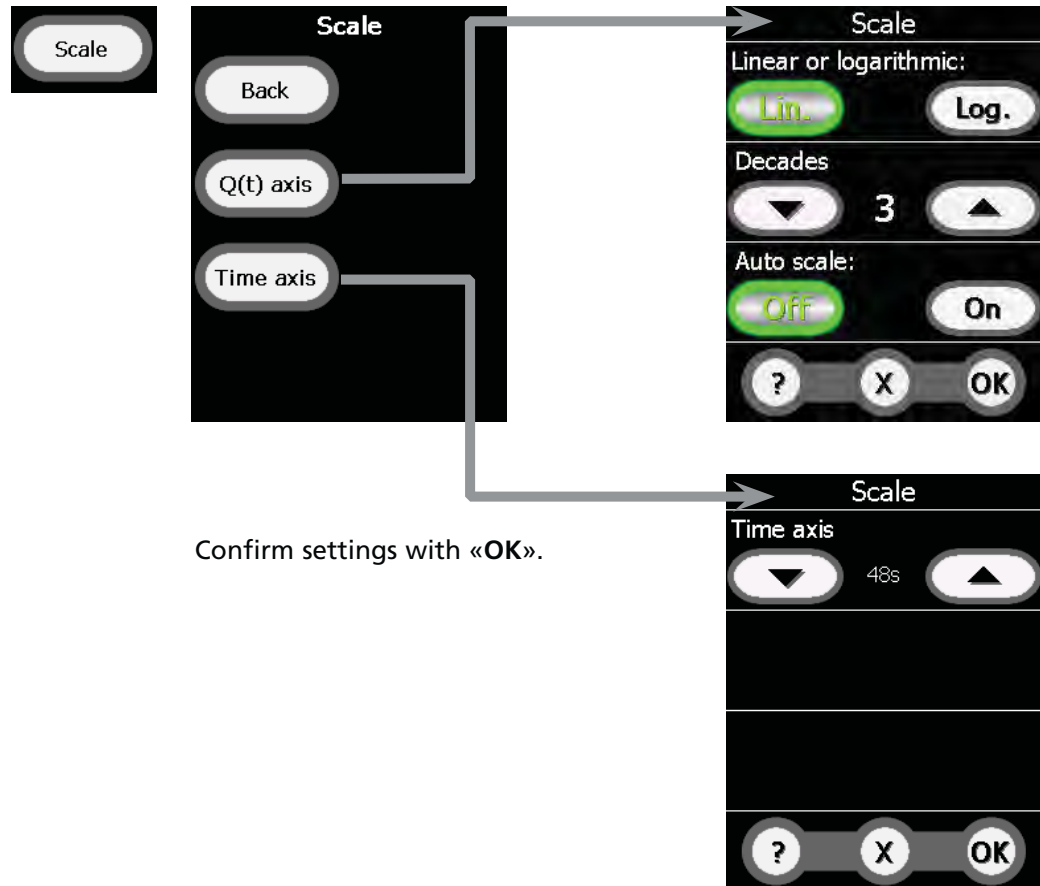

Confirm settings with «OK».

- Q(t) axis)

Opens a sub-menu allowing selecting:

- A linear or logarithmic display
- For logarithmic display, the number of decades displayed: select the decades number between 1 and 15 with buttons ▼ and ▲ (selected value is displayed in the centre).
- An automatic scale or not

- Time axis

Opens a sub-menu allowing defining the time axis scale.

- Selected time is the displayed range of the graph time axis.
- Set the value with ▼ and ▲ (selected value is displayed in the centre).

Wireless remote control (accessory)

Volume



Audio level setting for leak detector and remote control

Loudspeaker audio level can vary according to 15 levels (level 0 = volume is turned off).

Set the remote control audio level with buttons ▼ and ▲ (selected value is displayed in the centre).

Set the leak detector audio level with buttons ▼ and ▲ : audio level set from leak detector menu is automatically changed (📖 C 401).

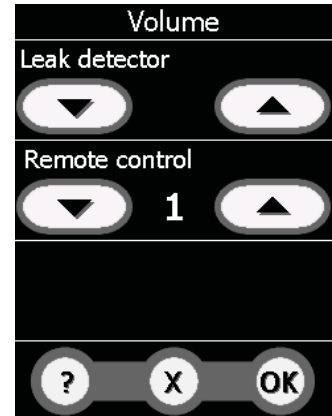

- The leak detector produces a sound when the reject point set in the leak detector menu (📖 C 401) is crossed.
- The remote control produces a sound when the reject point set in the remote control menu (§ Trigger) is crossed.

Wireless remote control (accessory)

Recorder Measurements recording

Copy and delete recorded data files

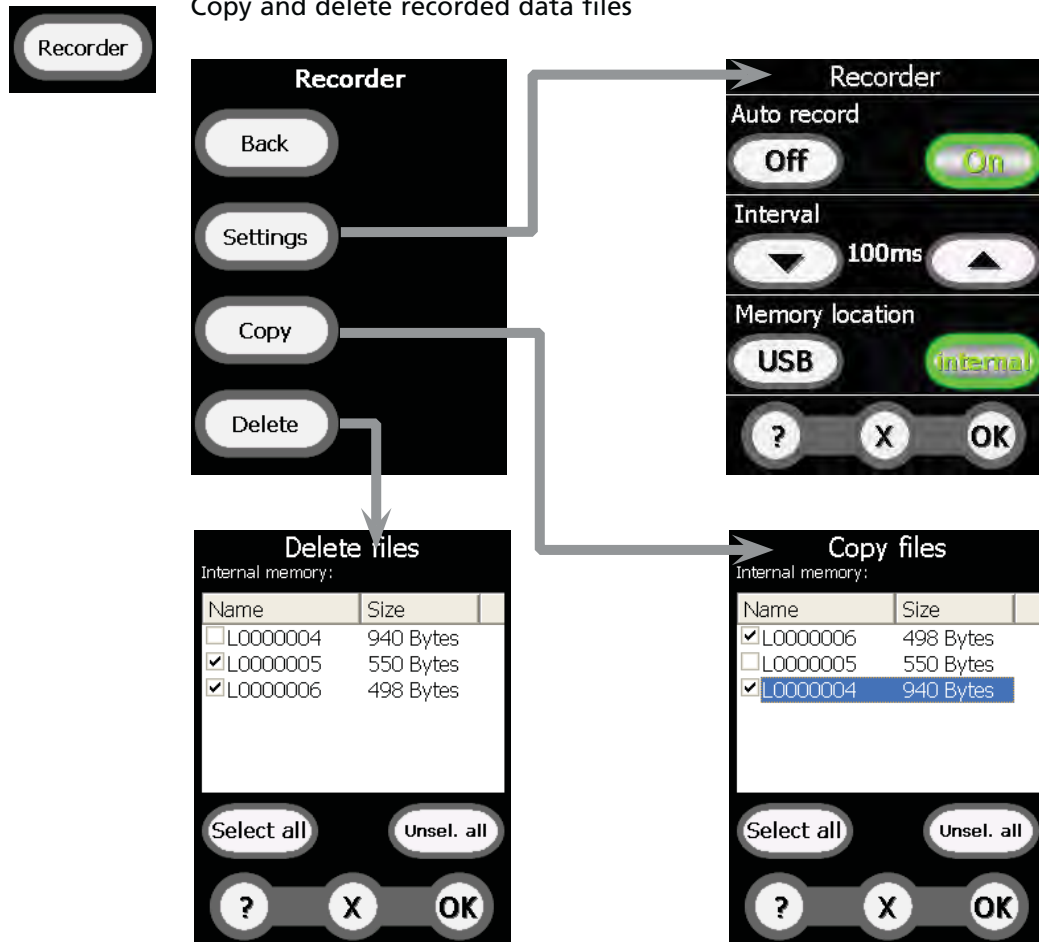

Confirm settings with «OK».

Wireless remote control (accessory)

■ Settings

Opens a sub-menu allowing:

- Starting/stopping measurements recording:
 - «auto record on» selected, new data file recording will start as soon as the leak detector is in test. Recording will be stop as soon as the leak detector is no more in test and the data file will be closed.
 - «auto record off» selected, no recording will be made.
- Setting recording parameters: interval corresponds to time between 2 measured values recorded in the data file. Set interval with buttons ▼ and ▲ (selected value is displayed in the centre).
- Memory location: recording can be saved either in the remote control internal memory or in the USB stick.

■ Copy

Opens a sub-menu allowing saving recorded data files in a USB stick.

- Plug a USB stick to the remote control.
- Select file(s) by clicking on it or use the «Select all» button.
- Press «OK» to copy selected file(s) in the USB stick.
- Confirm displayed message with «OK».
- USB stick can be unplugged.

■ Delete

Opens a sub-menu allowing deleting recorded data file(s) in the remote control internal memory:

- Select file(s) by clicking on it or use the «Select all» button.
- Press «OK» to delete selected file(s).
- Confirm displayed message with «OK» if selected file(s) must be deleted.
- A message confirms that selected file(s) has(have) been deleted: press «OK».

Wireless remote control (accessory)

Info Other information about battery, wireless connection and current software version.



Search in the 5 information pages the desired information with buttons ▼ and ▲.

Return to main menu with «OK».

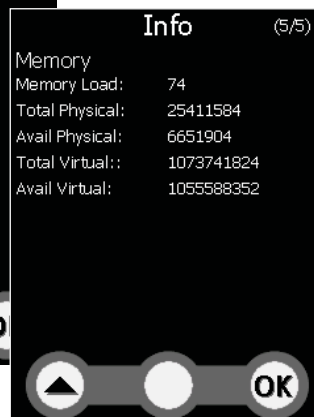
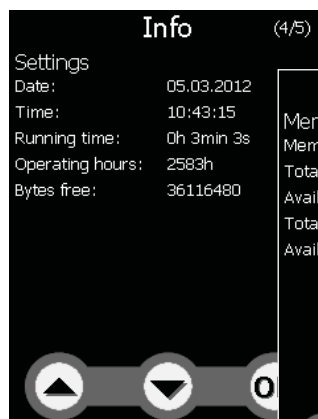
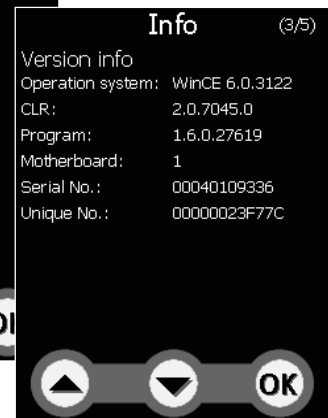
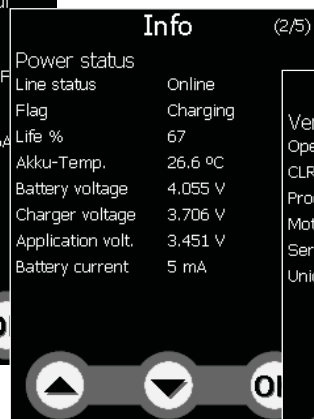
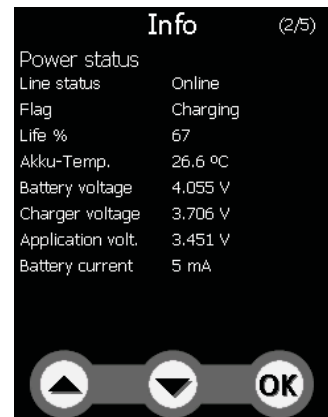

Wireless remote control (accessory)

Misc Setting of the language, time, date and display backlight.

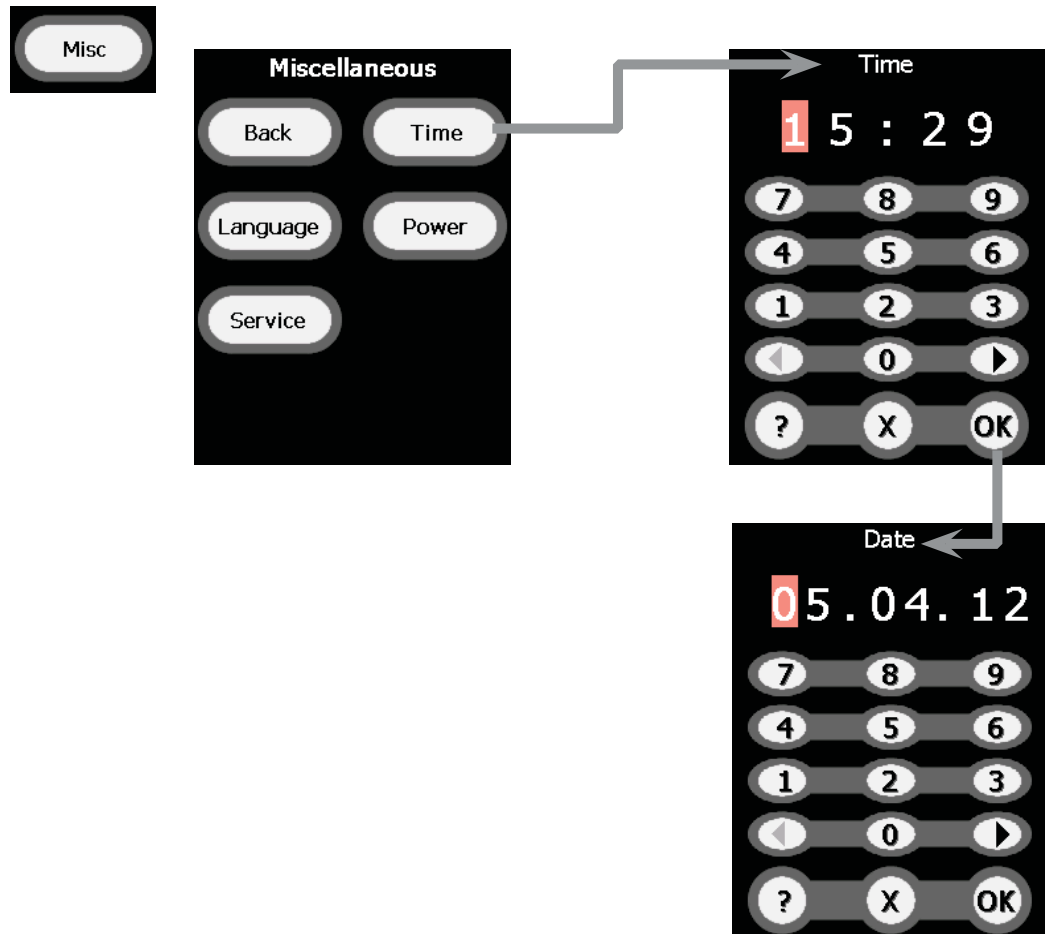

■ Time

Open a sub-menu allowing setting time. Each field to set can be selected with buttons ◀ and ▶. The selected field is marked red and can be changed. Use the numeric keypad to enter the desired digit. Confirm the set level with «OK»: a sub-menu allowing setting date opens. Set date in the same way.

Wireless remote control (accessory)

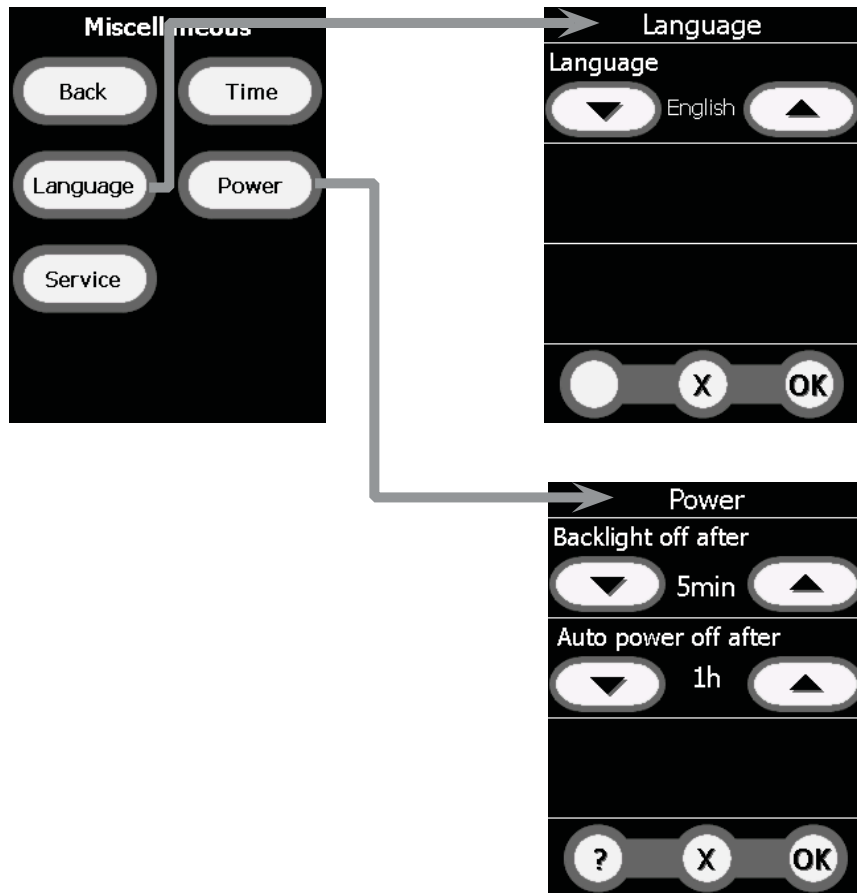

- Language

Opens a sub-menu allowing selecting the language.
 Languages proposed are: German – English – French – Spanish – Russian-Chinese.
 Select the desired languages with buttons ▼ and ▲ (selected value is displayed in the centre) and confirm «OK».

Wireless remote control (accessory)

- Power (display backlight)
 - Opens a sub-menu allowing setting display backlight and remote control automatic switch off.
 - Display backlight can be decreased after a period from 15 s to 10 mn. This reduces the power consumption and extends the battery use time. With a simple press on the display, display backlight comes back normal. Select the desired period with buttons ▼ and ▲ (selected value is displayed in the centre) and confirm «OK».
 - Remote control can switch off automatically if it is not used after a period between 5 mn and 4 h. Select the desired period with buttons ▼ and ▲ (selected value is displayed in the centre) and confirm «OK».

- Service
 - Opens a sub-menu accessible only to the Service Centers via a password.

Connection RC 500 WL is connected to the leak detector by means of a wireless connection thanks to an external radio transmitter (Bluetooth) delivered with the remote control. However, it is also possible to use the leak detector internal Bluetooth (in option or accessory).

With an external radio transmitter Connect the radio transmitter to the 9 pin Sub D of the leak detector.

Note: the operating range of the radio transmitter will be affected by metal objects in its near: avoid installing the antenna near such objects.

In «Advanced» menu of the leak detector, select «Serial link 1 = Serial» ( C 406).

To establish wireless connection, refer to «Main menu: Connect» chapter.

Wireless remote control (accessory)

With internal Bluetooth Connection to the leak detector internal Bluetooth module.

In «Advanced» menu of the leak detector, select «Serial link 2 = Bluetooth» (📖 C 406).

To establish wireless connection, refer to «Main menu: Connect» chapter.

Display RC 500 WL **connected**
to the leak detector



Leak detector ready to test

RC 500 WL **déconnecté**
au détecteur de fuites



To establish wireless connection, refer to «Main menu: Connect» chapter.

Connection can be lost during a test:

- disappearance of the symbol 
- display remains frozen on the value of the latest measurement realized before disconnection and becomes grey.

To establish again wireless connection, refer to «Main menu: Connect» chapter.



Wireless remote control (accessory)

Use After starting up, a start screen with a «Welcome» message displays.



The RC 500 WL remote control search a connection with a leak detector:

- If no connection is possible «No data connection» message displays.
- If a connection is established with a detector, operation display displays.

To come back to the operation display, press «BACK».

When leak detector is switched on, remote control indicates detector mode displayed on its control panel: «Starting detector» mode, then «Calibration» mode (according to leak detector setting) and finally «Standby mode».

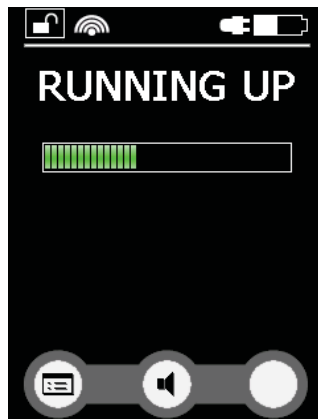

«Starting detector» mode

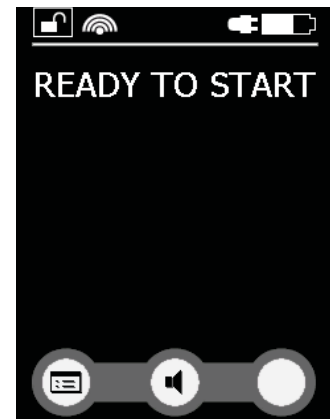

«Standby» mode
(detector ready for a test)

Wireless remote control (accessory)

If the leak detector calibration is set on «Starting», an autocalibration is automatically launched after «Starting detector» mode and this mode is indicated on the remote control.

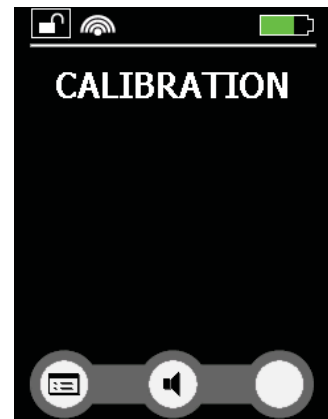

«Calibration» mode

«Start/Stop» button «Start/Stop» button on the remote control works in the same way as that situated on the leak detector. In any case, you have to respect the instructions indicated in the Operating instruction ( C 110).

- Pressing the button starts the leak test.
- Pressing the button again during the measurement stops the test
- Pressing at least 2 s on the button activates an air inlet ( C 402).

When a test is started, remote control indicates detector mode displayed on the leak detector control panel: «Roughing detector» mode and then «Measure» mode.

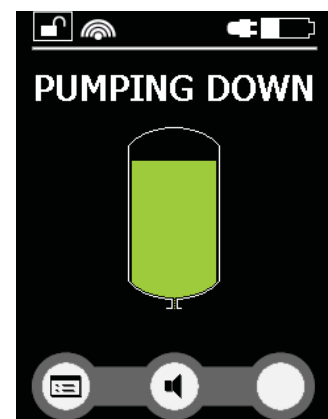

«Roughing» mode

Wireless remote control (accessory)

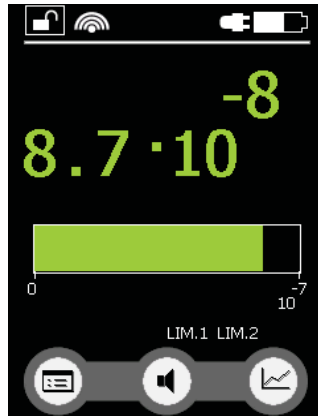

«Measure» mode
(digital/bargraph display)

or

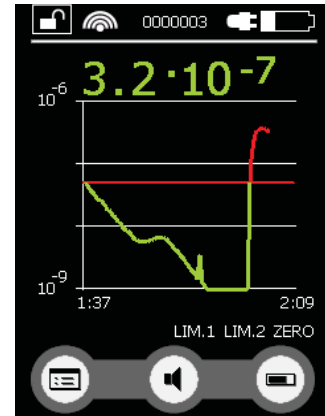

«Measure» mode
(graphic display)

Note: Press «Start/Stop» button more than 10 s allows resetting the remote control.

«ZERO» button «ZERO» button on the remote control works in the same way as that situated on the leak detector. In any case, you have to respect the instructions indicated in the Operating instruction C 406.

Press «ZERO» button activates the leak detector background suppression.

Paging function With the paging function, the RC 500 WL remote control can be easily located when you search it.

Access to the function from leak detector menus: «Advanced» → «Serial link x» (x = link on which «RC 500» mode is set) → «Parameters».

| Parameters | | |
|----------------|---------------------------------------|--|
| Mode : | <input type="button" value="RC 500"/> | |
| Paging Func. : | <input type="button" value="No"/> | |

When paging function is activated, the remote control emits «beep» regularly allowing localizing it easily. «Beep» emission stops as soon as the function is deactivated.

Paging function is available if adixen leak detector supervisor firmware version is \geq V3200.

Long distance sniffer probe and Helium spray gun (accessories)

Please refer to the specific sheets for the instruction:



Long distance sniffer probe



 G 400



Helium spray gun  G 500

Declaration of conformity



| DECLARATION OF CE CONFORMITY | |
|---|---|
| <p>We, adixen Vacuum Products 98, Avenue de Brogny, BP 2069 74009 ANNECY France</p> <p>ISO 9001 CERTIFIED</p> <p>declare under our sole responsibility that the following products</p> <p>ASM 380</p> <p>to which this declaration relates are in conformity with the relevant provisions of the following European Directives:</p> <p><u>2006/42/EC : Machinery directive</u></p> <p><u>2006/95/EC : Low voltage directive</u></p> <p><u>2004/108/EC : Electromagnetic Compatibility Directive</u></p> <p><u>2002/95/EC : Restriction of Hazardous Substances</u></p> <p>when used in accordance with the instruction manual of the product.</p> <p>Those products comply with the relevant provisions of the above Directives and carry the CE marking.</p> | |
| <p>Signatures:</p>  <p>Mr Eric TABERLET Président</p> | <p>Annecy, August 12, 2011</p> <p>Personne autorisée à constituer le dossier technique :</p>  <p>Mr Gilles BARET Directeur Produits et Technologie 98, Avenue de Brogny, BP 2069 74009 Annecy, France</p> |

GB 04.307 - Edition 02 - July 2011

Service

Pfeiffer Vacuum offers first-class customer service!

- On-Site maintenance for many products)
- Overhaul / repair in the nearby Service Location
- Fast replacement with refurbished exchange products in mint condition
- Advice on the most cost-efficient and quickest solution

Detailed information, addresses and forms at: www.pfeiffer-vacuum.com (Service).

Overhaul and repair in the Pfeiffer Vacuum Service Center

The following general recommendations will ensure a fast, smooth servicing process:

- ➔ Fill out the «Service Request/Product return» form and send it to your local Pfeiffer Vacuum Service contact.
- ➔ Include the confirmation on the service request from Pfeiffer Vacuum with your shipment.
- ➔ Fill out the declaration of contamination and include it in the shipment (mandatory!). The Declaration of contamination is valid for any product/device including a part exposed to vacuum.
- ➔ Dismantle all accessories and keep them.
- ➔ Close all the ports flange openings by using the original protective covers or metallic airtight blank flanges for contaminated devices.
- ➔ If possible, send pump or unit in its original packaging.

Sending of contaminated pumps or devices

No devices will be accepted if they are contaminated with micro-biological, explosive or radioactive substances. "Hazardous substances" are substances and compounds in accordance with the hazardous goods regulations (current version).

- ➔ Neutralize the pump by flushing it with nitrogen or dry air.
- ➔ Close all openings airtight.
- ➔ Seal the pump or device in suitable protective film.
- ➔ Return the pump/device only in a suitable and sturdy transport container and send it in while following applicable transport conditions.

Pump or device returned without declaration of contamination form fully completed and/or non-secured in a suitable packaging, will be decontaminated and/or returned at the shipper's expense.

Exchange or repaired devices

The factory operating parameters are always preset with exchange or repaired devices. If you use specific parameters for your application, you have to set these again.

Service orders

All service orders are carried out exclusively according to our general terms and conditions for the repair and maintenance, available in our website.

**Vacuum Solutions
from a single Source**

Pfeiffer Vacuum stands for innovative and custom vacuum solutions worldwide, technological perfection, competent advice and reliable service.

**Complete range
of products**

From a single component to complex systems: We are the only supplier of vacuum technology that provides a complete product portfolio.

**Competence in
theory and practice**

Benefit from our know-how and our portfolio of training opportunities! We support you with your plant layout and provide first-class on-site service worldwide.

**Are you looking for a
perfect vacuum solution?
Please contact us:**

Pfeiffer Vacuum GmbH
Headquarters
T +49 6441 802-0
Info@pfeiffer-vacuum.de

