

Turbo-V 81-AG Rack Controller

Model 969-8988

Model 969-8989

Model 969-8990

Turbo-V 81-AG Rack Controller

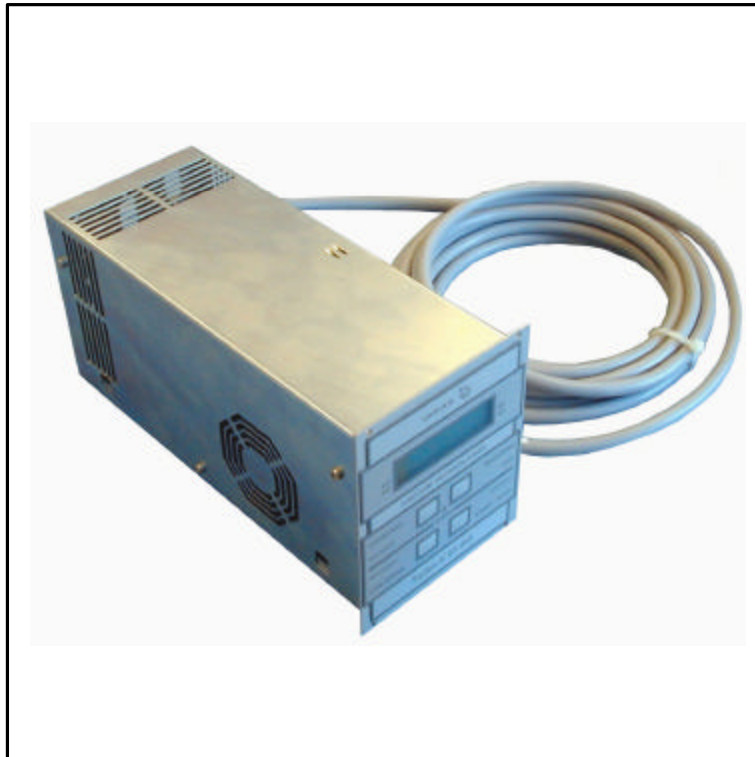

VARIAN



vacuum technologies

Dear Customer,

Thank you for purchasing a VARIAN vacuum product. At VARIAN Vacuum Technologies we make every effort to ensure that you will be satisfied with the product and/or service you have purchased.

As part of our Continuous Improvement effort, we ask that you report to us any problem you may have had with the purchase or operation of our product. On the back side you find a Corrective Action Request form that you may fill out in the first part and return to us.

This form is intended to supplement normal lines of communications and to resolve problems that existing systems are not addressing in an adequate or timely manner.

Upon receipt of your Corrective Action Request we will determine the Root Cause of the problem and take the necessary actions to eliminate it. You will be contacted by one of our employees who will review the problem with you and update you, with the second part of the same form, on our actions.

Your business is very important to us. Please, take the time and let us know how we can improve.

Sincerely,

Sergio PIRAS

*Vice President and General Manager
VARIAN Vacuum Technologies*

Note: Fax or mail the Customer Request for Action (see backside page) to VARIAN Vacuum Technologies (Torino) - Quality Assurance or to your nearest VARIAN representative for onward transmission to the same address.

CUSTOMER REQUEST FOR CORRECTIVE / PREVENTIVE / IMPROVEMENT ACTION

TO : VARIAN VACUUM TECHNOLOGIES TORINO - QUALITY ASSURANCE

FAX N° : XXXX - 011 - 9979350

ADDRESS: VARIAN S.p.A. - Via F.lli Varian, 54 - 10040 Leinì (Torino) - Italy

E-MAIL : marco.marzio@varianinc.com

NAME _____	COMPANY _____	FUNCTION _____
<p>ADDRESS : _____</p> <p>TEL. N° : _____ FAX N° : _____</p> <p>E-MAIL : _____</p>		
<p>PROBLEM / SUGGESTION :</p> <p>_____</p> <p>_____</p> <p>_____</p> <p>_____</p>		
<p>REFERENCE INFORMATION (model n°, serial n°, ordering information, time to failure after installation, etc.) :</p> <p>_____</p> <p>_____</p> <p>_____</p> <p style="text-align: right;">DATE _____</p>		

<p>CORRECTIVE ACTION PLAN / ACTUATION (by VARIAN VTT)</p> <p>_____</p> <p>_____</p> <p>_____</p> <p>_____</p> <p>_____</p>	<p>LOG N° _____</p>
--	---------------------

XXXX = Code for dialing Italy from your country (es. 01139 from USA; 00139 from Japan, etc.)



INSTRUCTIONS FOR USE	65
TECHNICAL INFORMATION.....	69
TURBO-V 81 RACK CONTROLLER DESCRIPTION	69
CONTROLLER SPECIFICATIONS	70
CONTROLLER OUTLINE	70
CONTROLLER CONNECTION.....	71
J6 - Fan	71
J7 - Vent.....	71
P1 - Input	72
J1 - Output.....	73
Pump Connector	77
Pump Driving.....	78
Stop Speed Reading and Active Stop	78

J5 - GAUGE CONNECTOR	77
J2 - SERIAL CONNECTOR.....	78
Serial Communication Descriptions	79
Window Protocol	81
Window Meanings	83
HOW TO USE FRONT PANEL.....	86
General.....	88
Startup.....	89
Programming.....	91
Configuration menu	91
MODE menu.....	92
PUMP SETTING menu	92
INPUT/OUTPUT menu.....	93
GAUGE menu	94
SERIAL menu.....	95
HOW TO USE BY REMOTE I/O	96
HOW TO USE IN SERIAL MODE	96
PROFIBUS OPTION	97
General.....	97
Installation	97
Configuration	97
Software Operation and State Machine	97
Message Mapping	98
Parameter Buffer	99
Output Buffer	102
Input Buffer	103
Diagnostic Management.....	105
Diagnostic Buffer.....	105
ERROR MESSAGES.....	106
ORDERABLE PARTS.....	107

GENERAL INFORMATION

This equipment is destined for use by professionals. The user should read this instruction manual and any other additional information supplied by Varian before operating the equipment. Varian will not be held responsible for any events occurring due to non-compliance, even partial, with these instructions, improper use by untrained persons, non-authorized interference with the equipment or any action contrary to that provided for by specific national standards. The Turbo-V 81-AG Rack controllers are micro-processor-controlled, solid-state, frequency converter with self-diagnostic and self-protection features.

Controller features:

- Front / Remote / Serial Operation
- 24Vdc pump fan cooling drive
- Vent valve drive
- Pump speed reading after stop command (stop speed reading)
- Pressure reading
- Input voltage auto setting.
- Profibus interface (optional)

The following paragraphs contain all the information necessary to guarantee the safety of the operator when using the equipment. Detailed information is supplied in the appendix "Technical Information".

This manual uses the following standard protocol:



WARNING!

The warning messages are for attracting the attention of the operator to a particular procedure or practice which, if not followed correctly, could lead to serious injury.



CAUTION!

The caution messages are displayed before procedures which, if not followed, could cause damage to the equipment.

NOTE

The notes contain important information taken from the text.

STORAGE

When transporting and storing the controllers, the following environmental requirements should be satisfied:

- temperature: from -20 °C to + 70 °C
- relative humidity: 0 - 95%
(without condensation)

PREPARATION FOR INSTALLATION

The controller is supplied in a special protective packing. If this shows signs of damage which may have occurred during transport, contact your local sales office. When unpacking the controller, ensure that it is not dropped or subjected to any form of impact. Do not dispose of the packing materials in an unauthorized manner. The material is 100% recyclable and complies with EEC Directive 85/399.

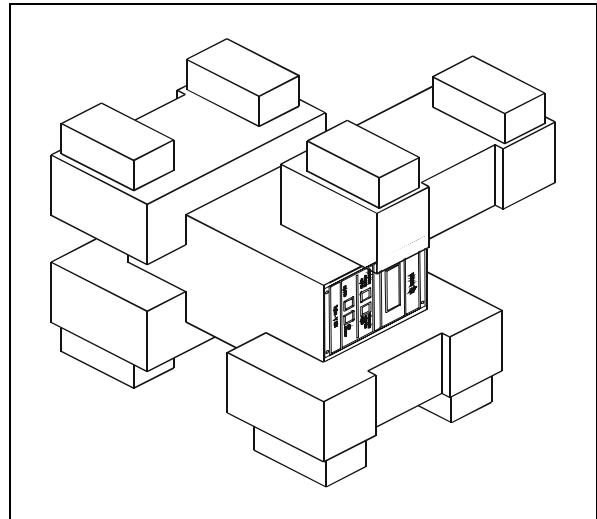

Controller Packing

INSTALLATION



WARNING!

The Turbo-V controller must be powered with 3-wire power cord (see orderable parts table) and plug (internationally approved) for user's safety. Use this power cord and plug in conjunction with a properly grounded power socket to avoid electrical shock and to satisfy CE requirements. High voltage developed in the controller can cause severe injury or death. Before servicing the unit, disconnect the input power cable.

NOTE

The Turbo-V controller can be used as a bench unit or a rack module, but it must be positioned so that free air can flow through the holes. Do not install or use the controller in an environment exposed to atmospheric agents (rain, snow, ice), dust, aggressive gases, or in explosive environments or those with a high fire risk.

During operation, the following environmental conditions must be respected:

- temperature: from 5 °C to +45 °C
- relative humidity: 0 - 95% (without condensation)

See the appendix "Technical Information" for detailed information about the above mentioned and the other connections, and about the options installation.

USE

This paragraph describes the fundamental operating procedures. Detailed information and operating procedures that involve optional connections or options are supplied in the paragraph "USE" of the appendix "Technical Information".

Make all vacuum manifold and electrical connections and refer to Turbo-V pump instruction manual prior to operating the Turbo-V controller.



WARNING!

To avoid injury to personnel and damage to the equipment, if the pump is lying on a table make sure it is steady. Never operate the Turbo-V pump if the pump inlet is not connected to the system or blanked off.

NOTE

The input signal J1 connector should be left in position including the shipping links if no external connections are made. The forepump and the Turbo-V pump can be switched on at the same time.

Controls, Indicators and Connectors

The following paragraph illustrates the Controller front panel and rear panel. More details are contained in the appendix "Technical Information".

Front Panel Description

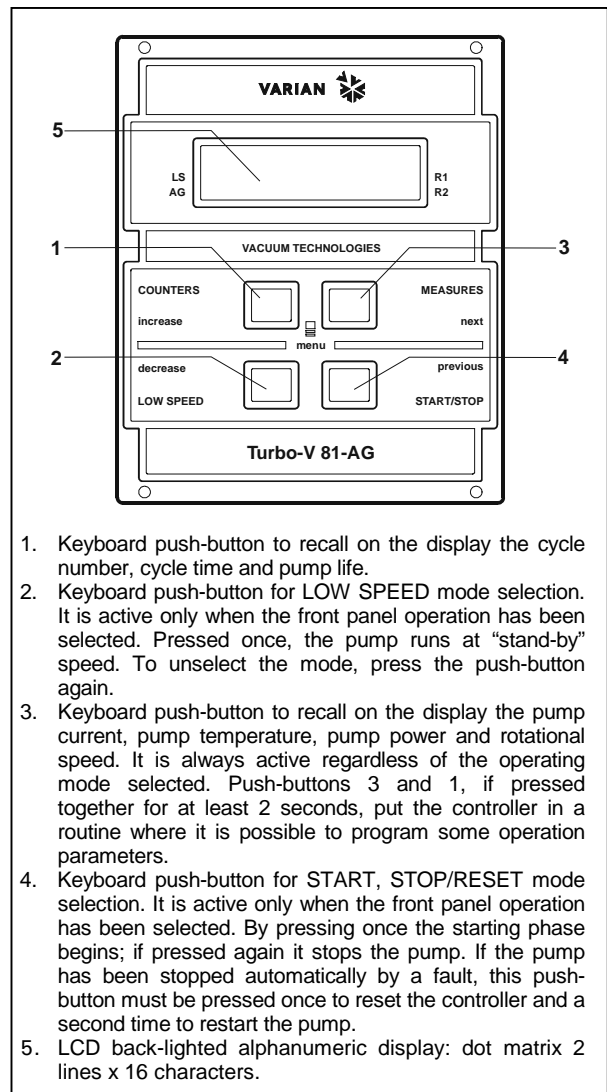

1. Keyboard push-button to recall on the display the cycle number, cycle time and pump life.
2. Keyboard push-button for LOW SPEED mode selection. It is active only when the front panel operation has been selected. Pressed once, the pump runs at "stand-by" speed. To unselect the mode, press the push-button again.
3. Keyboard push-button to recall on the display the pump current, pump temperature, pump power and rotational speed. It is always active regardless of the operating mode selected. Push-buttons 3 and 1, if pressed together for at least 2 seconds, put the controller in a routine where it is possible to program some operation parameters.
4. Keyboard push-button for START, STOP/RESET mode selection. It is active only when the front panel operation has been selected. By pressing once the starting phase begins; if pressed again it stops the pump. If the pump has been stopped automatically by a fault, this push-button must be pressed once to reset the controller and a second time to restart the pump.
5. LCD back-lighted alphanumeric display: dot matrix 2 lines x 16 characters.

Controller Turbo-V 81-AG Front Panel

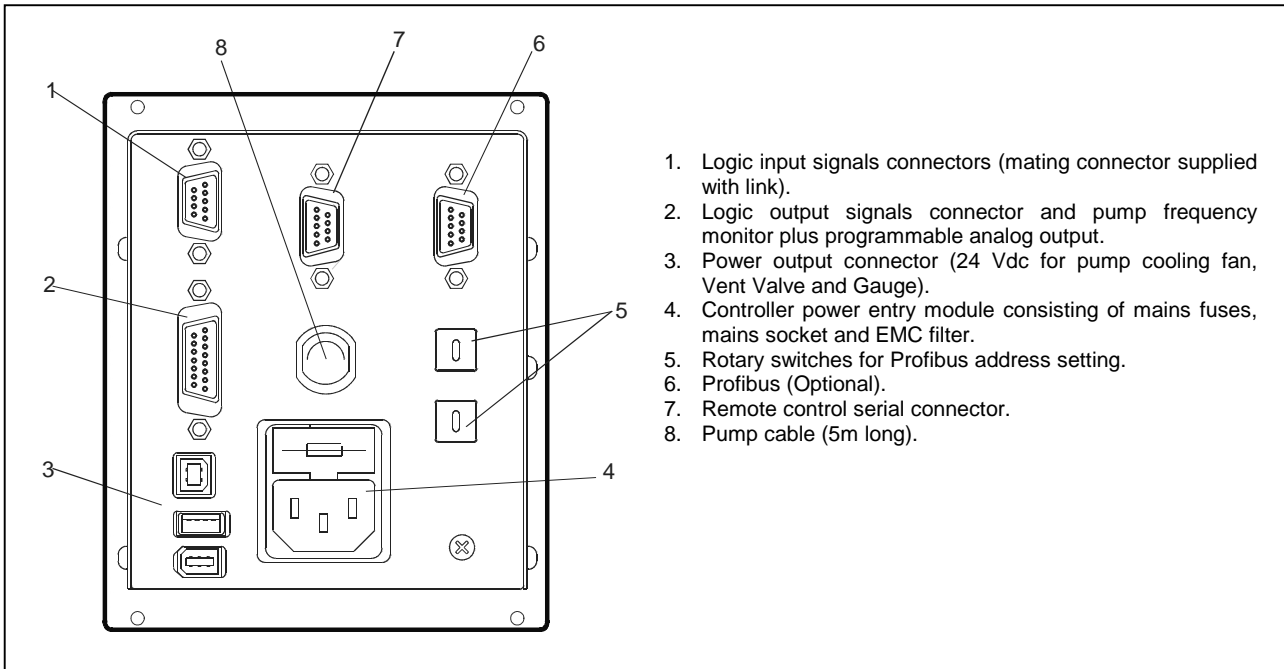

Controller Turbo-V 81-AG Rear panel

USE PROCEDURE

Controller Startup

To startup the controller plug the power cable into a suitable power source.

Starting the Pump

To start the pump, confirm the interlock input and press the START pushbutton on the controller front panel.

Pump Shutdown

To shutdown the pump press the STOP pushbutton on the controller front panel.

MAINTENANCE

The Turbo-V 81-AG Rack series controller does not require any maintenance. Any work performed on the controller must be carried out by authorized personnel.

When a fault has occurred it is possible to use the Varian repair service. Replacement controllers are available on an advance exchange basis through Varian.



WARNING!

Before carrying out any work on the controller, disconnect it from the supply.

If a controller is to be scrapped, it must be disposed of in accordance with the specific national standards.

DISPOSAL

Meaning of the "WEEE" logo found in labels

The following symbol is applied in accordance with the EC WEEE (Waste Electrical and Electronic Equipment) Directive.

This symbol (**valid only in countries of the European Community**) indicates that the product it applies to must NOT be disposed of together with ordinary domestic or industrial waste but must be sent to a differentiated waste collection system.

The end user is therefore invited to contact the supplier of the device, whether the Parent Company or a retailer, to initiate the collection and disposal process after checking the contractual terms and conditions of sale.



ERROR MESSAGES

For a certain type of failure, the controller will self-diagnose the error and the messages described in the following table are displayed.

MESSAGE	DESCRIPTION	REPAIR ACTION
CHECK CONNECTION TO PUMP	Wrong connection between the pump and the controller. Or The pump's temperature is below 0 °C.	Check connection between controller and pump. Press the START push-button twice to start the pump.
WAITING INTERLOCK	The interlock signal of P1 connector is activated by an interruption of the link between pin 3 and 8 of J1 connector, or because the external interlock signal is open.	Reset the short circuit between pin 3 and pin 8 of J1 connector, or close the external interlock signal.
PUMP OVERTEMP.	The upper bearing/pump temperature exceeds 60 °C.	Wait until the temperature decrease below threshold value. Press the START push-button twice to start the pump.
CONTROLLER OVERTEMP.	The controller environment temperature exceeds 70 °C. Or The controller's radiator temperature is above 60 °C.	Wait until the temperature decrease below threshold value. Press the START push-button twice to start the pump.
TOO HIGH LOAD	The current drawn by the pump is higher than programmed.	Check that the pump rotor is free to rotate. Press the START push-button twice to start the pump.
SHORT CIRCUIT	After the starting phase the output connection is shorted.	Check connections and shortages between pump and controller. Press the START push-button twice to start the pump.
SYSTEM OVERRIDE	The pump is stopped by an emergency stop signal provided via a remote contact.	Remove the controller power cable and check the emergency condition. Then reconnect the power cable and press the START push-button twice to start the pump.
OVERVOLTAGE	Controller power supply circuitry is faulty, or the Controller received a spike.	Press the START push-button twice to start the pump. Should the message still be present, call the Varian service.
POWER FAIL	Failure in the controller's pump power supply section.	Contact Varian for Maintenance.

TURBO-V 81-AG RACK CONTROLLER DESCRIPTION

The controller is available in three models (see orderable parts table):

- base version
- with RS 232-485 option
- with Profibus option

The controller is a solid-state frequency converter with the following features:

- Drives the pumps of the 81-NAV family.
- Powers the pump cooling fan
- Drives the vent valve.
- Provides and acquires the pressure of the wide range gauge.
- Remote I/Os compatible with the previous version.
- Navigator default serial compatible with the previous RS 232 and 485 version.
- Speed reading after stop command.

See the following diagram for the connections and orderable parts.

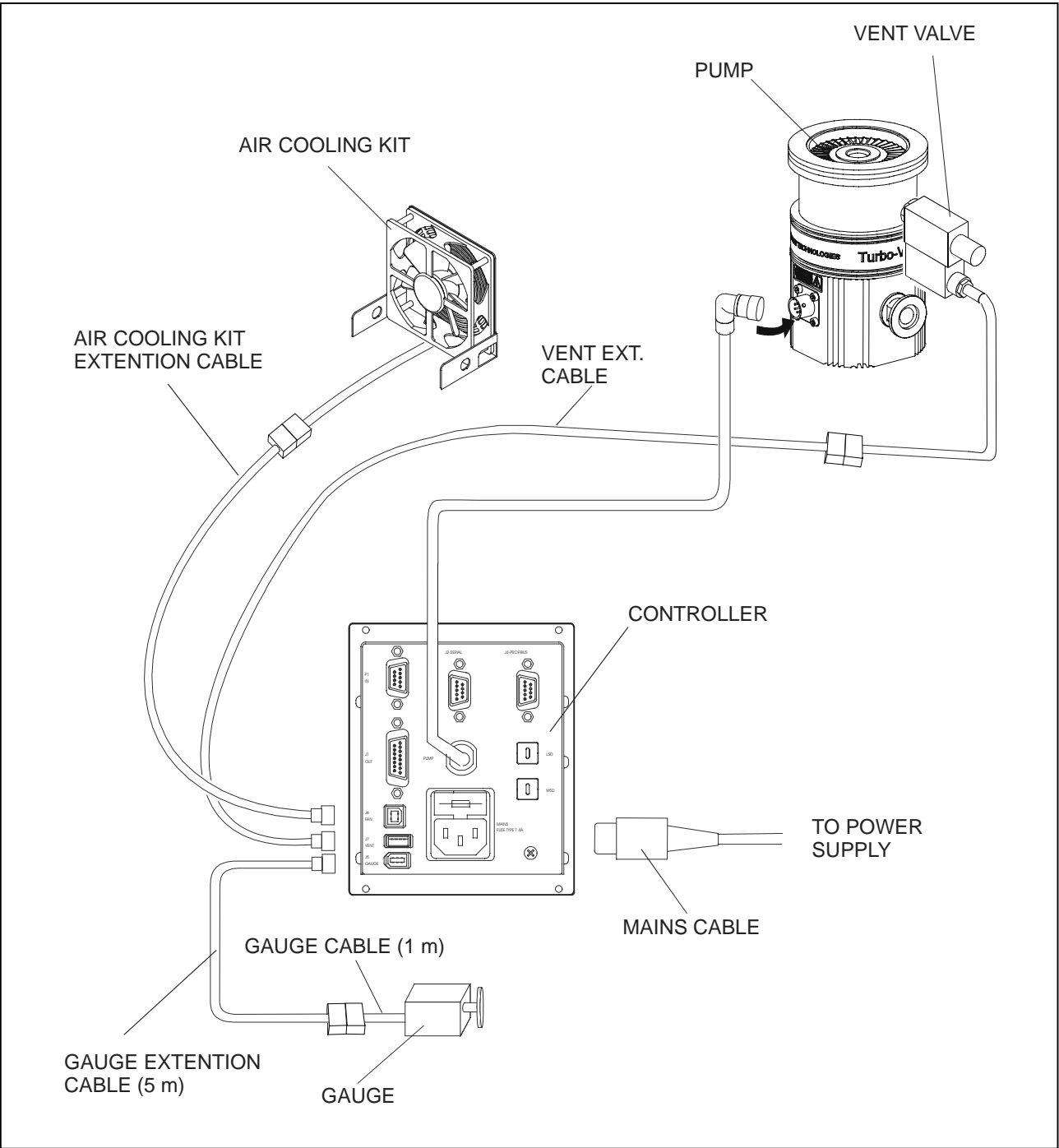

Turbo-V 81-AG Rack Controller – Connections

CONTROLLER SPECIFICATIONS

Input:	
Voltage	100, 240 Vac
Frequency	50 to 60 Hz
Power	210 VA
Fuse	2 x T4 A (slow blow) 250 V
Output:	
Voltage	76 Vac
Frequency	1350 Hz
Power	100 W
Environment storage	-20 °C to +70 °C 0-95%
Operating	+5 - +45 °C 0 – 90%

Applied norr.	EN 61010 -1 EN 55011 (Class-A) EN 61000-3-2, EN 61000-3-3, EN 61000-6-2, EN 61000-4-2,3,4,5,6,11,8
Weight:	1.7 Kg (3.2 lbs)
Pollution Degree	2
Installation Category	II

CONTROLLER OUTLINE

The outline dimensions for the Turbo-V 81-AG Rack controllers are shown in the following figure.

NOTE

The Controller must be positioned in such way that the mains cable can be easily disconnected.

NOTE

The Turbo-V controller can be used as a bench unit or as a rack module, but it must be positioned so that free air can flow through the holes.

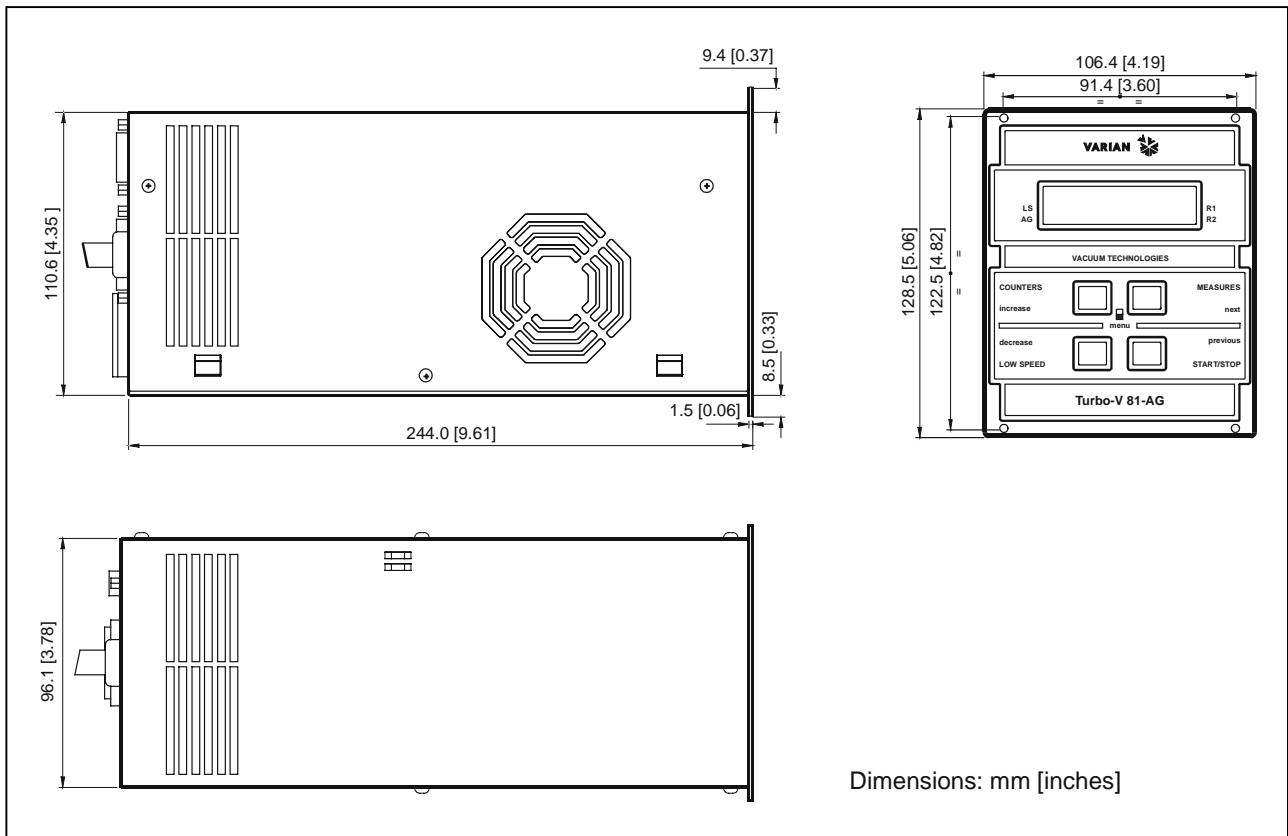

Controller Outline

CONTROLLER CONNECTION

J6 - Fan

The 24 Vdc, 150 mA maximum output voltage is present after START pushbutton is pressed and will remain present until a fault condition is displayed on front panel display or the turbopump is stopped. This is a dedicated output for the optional Turbo-V 81-AG pump cooling fan (see orderable parts table).

If you already have fan installed, use the available adapter cable to connect to the pump.

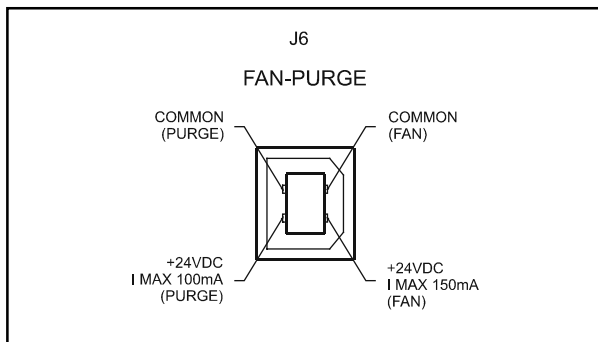

Fan Connector

J7 - Vent

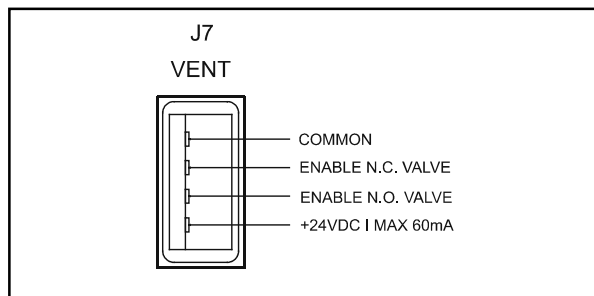

Vent Connector

This is dedicated 24 Vdc connector to control the optional vent valve (see orderable parts table). The vent valve can be driven by controller automatically or by serial line.

If you already have a vent valve installed 110 Vac powered, this valve must be replaced by a new model (see orderable parts table).

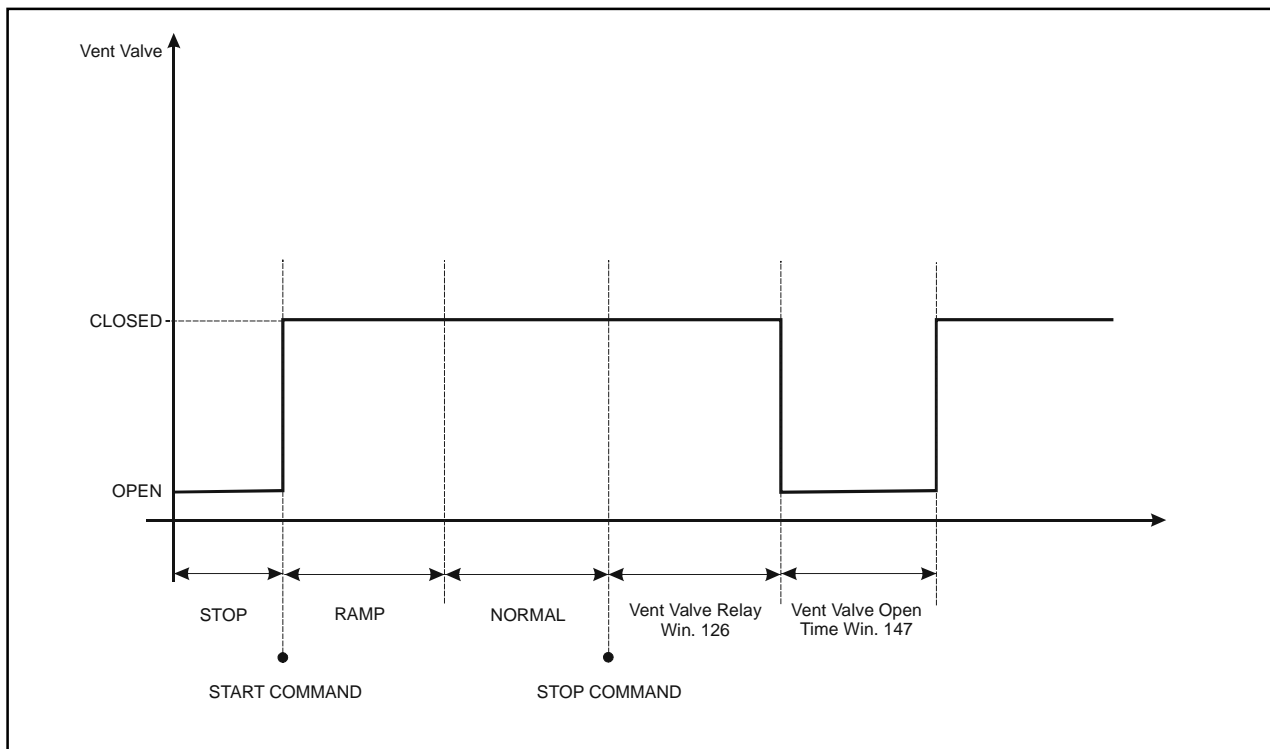

Vent Valve diagram in "Auto" mode

P1 – Input

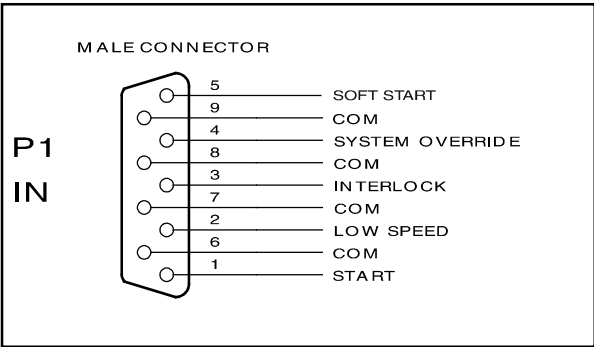

P1 Input Connector

All the logic input to the controller **must** be connected at J1 mating connector.

With the provided J1 mating connector (shipped with pin 3 and pin 8 shorted) make the connections with AWG 24, (0.24 mm²) or smaller wire to the pins indicated in the figure to obtain the desired capability.

The following table describes the signals available on the connector.

Pins	Name	Description	Electrical	Note
1-com	Start/Stop	Contact closed = Start Contact open = Stop	Optically isolated Vlow, max = 10v Imax = 5mA Imin (on) = 2mA	Active only in Remote Mode operation
2-com	Low Speed	Contact closed = Low Speed Contact open = High Speed	Optically isolated Vlow, max = 10v Imax = 5mA	Active only in Remote Mode operation
3-com	Interlock	Contact closed = Active Contact open = Inactive If active allows the pump running, if inactive stops the pump.	Optically isolated Vlow, max = 10v Imax = 5mA Imin (on) = 2mA	Active in all modes
4-com	System Override	Contact closed = Active Contact open = Inactive If active allows the pump running, if active stops the pump and all the others connected devices (Fan, Vent Valve...).	Optically isolated Vlow, max = 10v Imax = 5mA Imin (on) = 2mA	Active in all modes
5-com	Soft Start	Contact closed= Active Contact open= Inactive If active before the start command activates the spft start procedure. To be used only at first pump run-up.	Optically isolated Vlow, max = 10v Imax = 5mA Imin (on) = 2mA	Active only in Remote Mode operation, and in STOP status.

The following figure shows a typical contact logic input connection and the related simplified circuit of the controller.

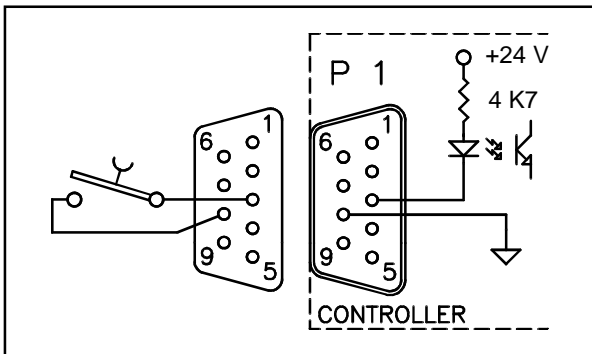

Typical Logic Input Connection

J1 – Output

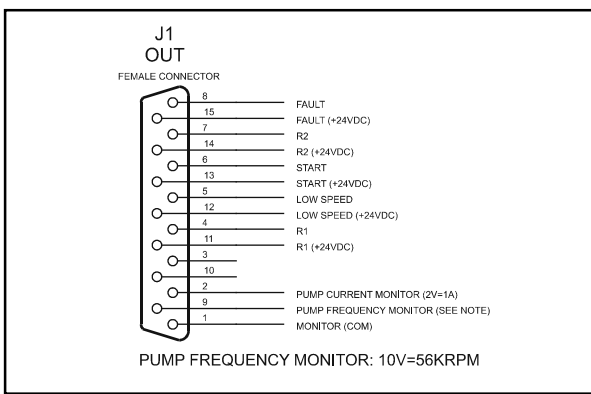

Logic Output Connector

All the logic output from the controller must be connected at P2 mating connector. The following table describes the signals available on the connector.

Pins	Name	Description	Electrical	Note
15-8	Fault	0V = no fail 24V = fail	Optically isolated Vmax (=open) = 24v Vlow, max = 1,5v Imax = 60mA Pin-8 negative Pin-15 positive	Connect a 10kohm resistor between the 2 pins before measuring voltage A STOP command (by front Panel or serial or Start/stop input) reset the FAIL status.
13-6	Start	Configurable output. Default setting (win.177 = 0): 24V pump in RAMP state, 0V = other state. If win.177 = 1: 0V = pump in stop or FAIL status, 24V = other state	Optically isolated Vmax (=open) = 24v Vlow, max = 1,5v Imax = 60mA Pin-6 negative Pin-13 positive	Connect a 10kohm resistor between the 2 pins before measuring voltage
12-5	Low Speed	24V = low speed active 0V = low speed not active	Optically isolated Vmax (=open) = 24v Vlow, max = 1,5v Imax = 60mA Pin-5 negative Pin-12 positive	Connect a 10kohm resistor between the 2 pins before measuring voltage
11-4	R1	Programmable Set Point Out Can be related to: Frequency, Power, Time Status or Pressure. See following figures for more details. All the setting can be done by: front panel or serial line (win.101 to 105 and 162).	Optically isolated Vmax (=open) = 24v Vlow, max = 1,5v Imax = 60mA Pin-5 negative Pin-12 positive	Connect a 10kohm resistor between the 2 pins before measuring voltage

The following figure shows a typical logic output connection (relay coil) but any other device may be connected e.g. a LED, a computer, etc., and the related simplified circuit of the controller.

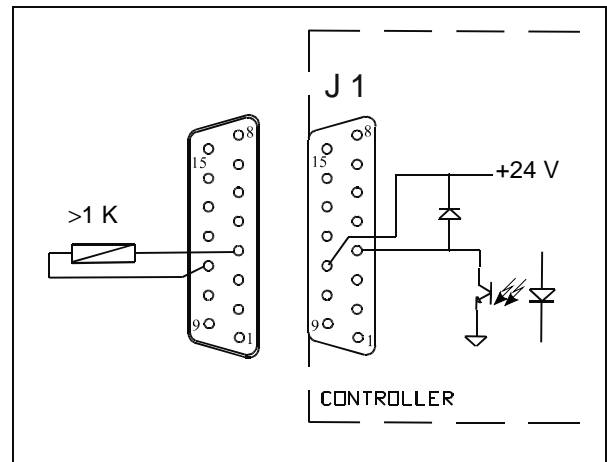

Digital Output Connection Example

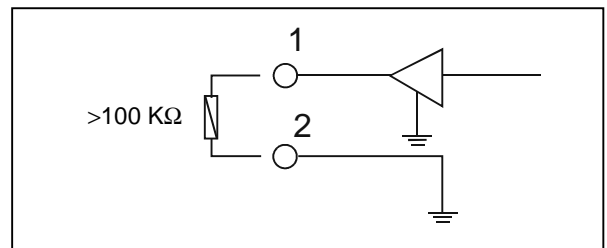

Analog Output Connector Example

Pins	Name	Description	Electrical	Note
14-7	R2	Programmable Set Point Out Can be related to: Frequency, Power, Time Status or Pressure. See following figures for more details. All the setting can be done by: front panel or serial line (win.171 to 176).	Optically isolated Vmax (=open) = 24v Vlow, max = 1,5v Imax = 60mA Pin-7 negative Pin-14 positive	Connect a 10kohm resistor between the 2 pins before measuring voltage
2-1	Programmable Analog Output	Programmable analog output. Can be related to : frequency, power, pump temperature (linear) or pressure (logarithmic). The setting can be done by: front panel or serial line (win.111). 0V = 0Hz, 0W, 0°C 10V = 963Hz, 150W, 100°C See following chart for more details	Optically isolated Rload, min = 10kr Ripple Vpp,max = 200mv Precision = 5% Resolution = 40mv Pin-1 negative Pin-2 positive	Connect a 100kohm resistor between the 2 pins before measuring voltage
9-1	Frequency Analog Output	Analog output proportional to frequency (linear). 0V = 0Hz 10V = 963Hz	Optically isolated Rload, min = 10kr Ripple Vpp,max = 200mv Precision = 1% Resolution = 40mv Pin-1 negative Pin-9 positive	

R1 – R2 OUTPUT DIAGRAMS:

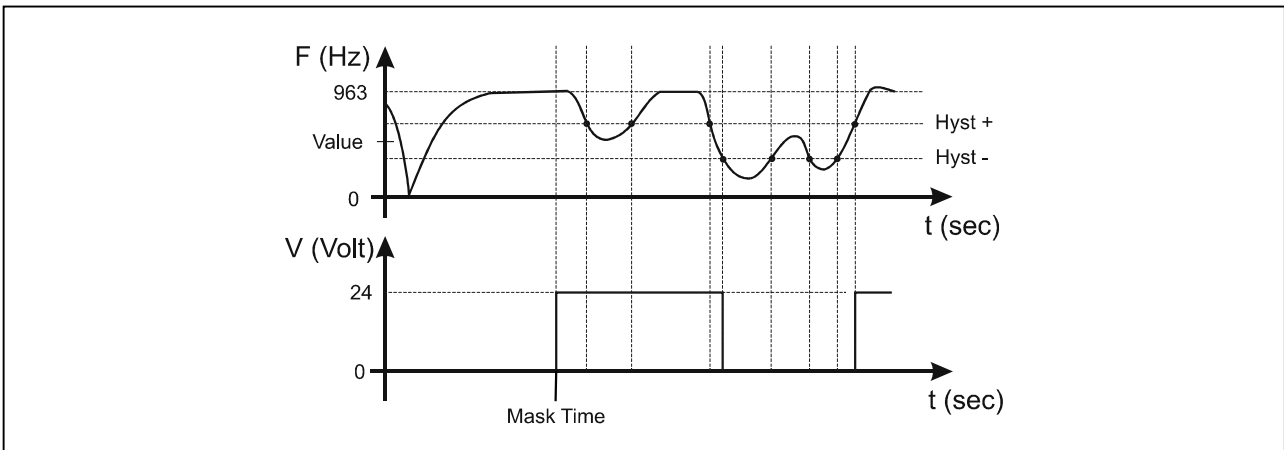

Diagram 1 – R1 or R2 related to frequency

+

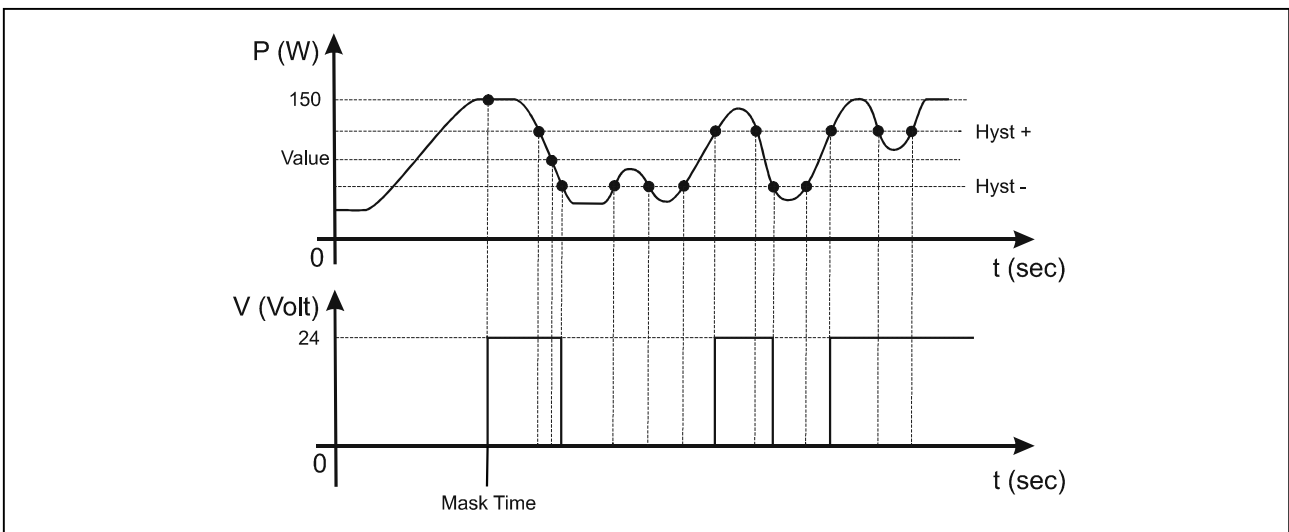

Diagram 2 – R1 or R2 related to power

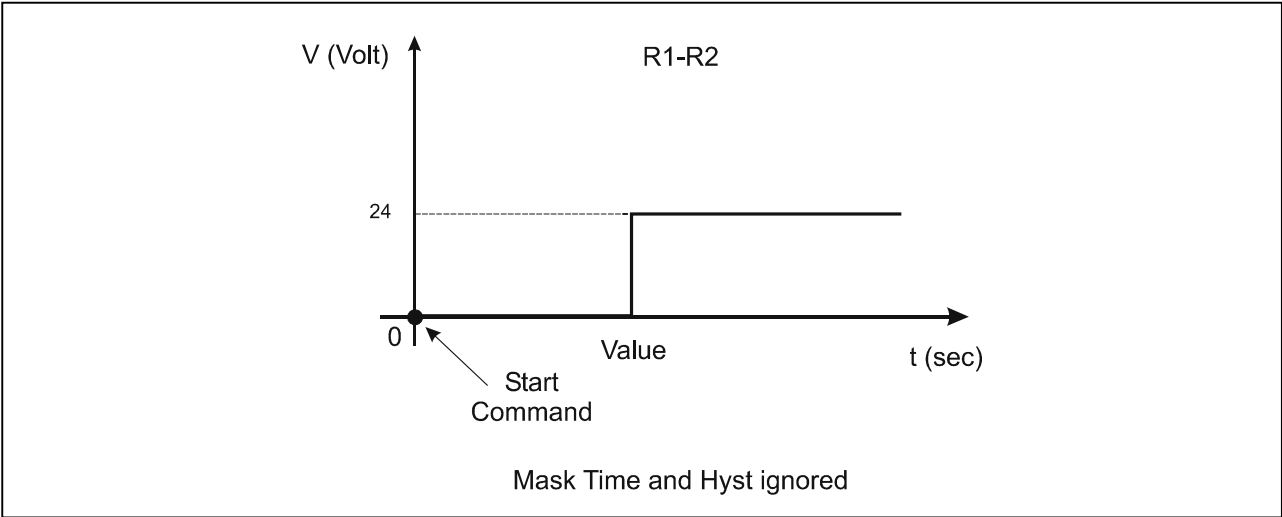

Diagram 3 – R1 or R2 related to time

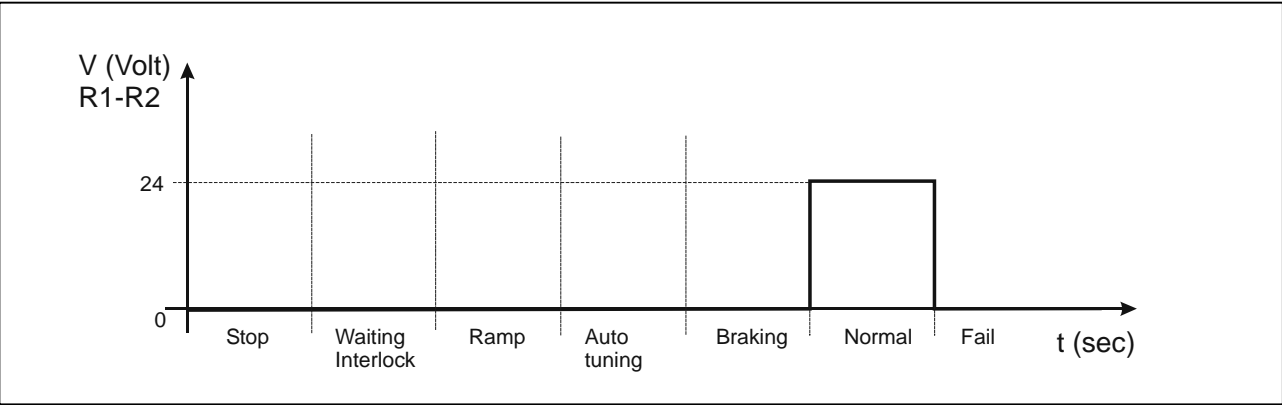

Diagram 4 – R1 or R2 related to Normal status

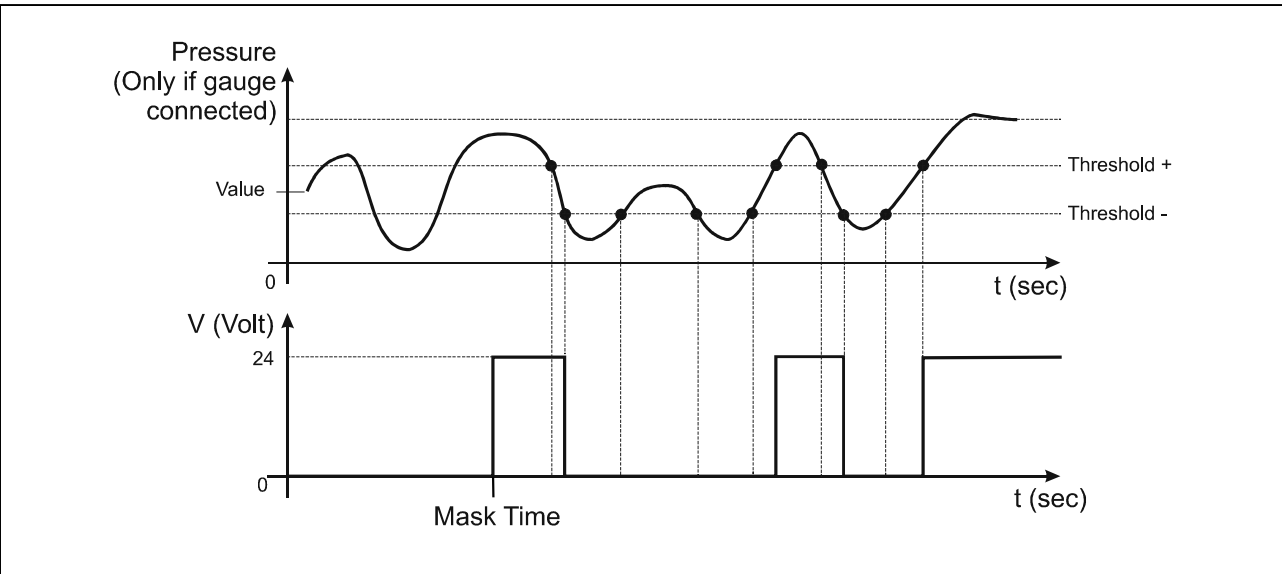

Diagram 5 – R1 or R2 related to pressure reading (if gauge connected)

PROGRAMMABLE ANALOG OUTPUT DIAGRAMS:

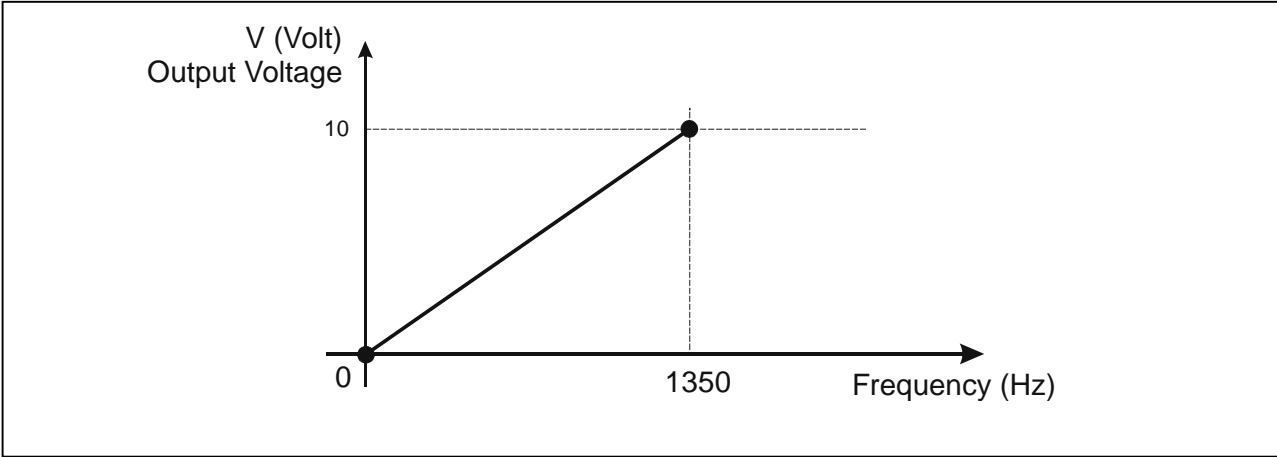

Diagram 1 – Programmable analog output related to frequency

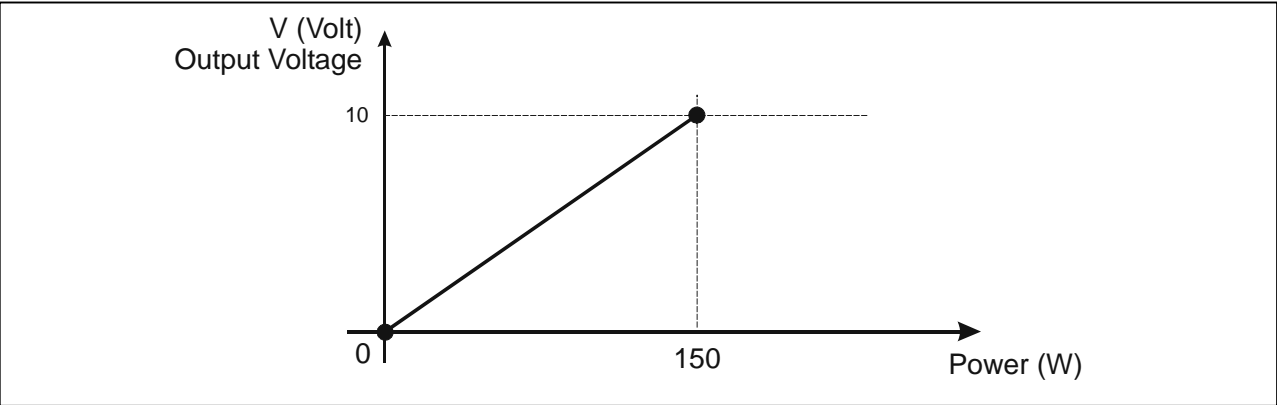

Diagram 2 – Programmable analog output related to power

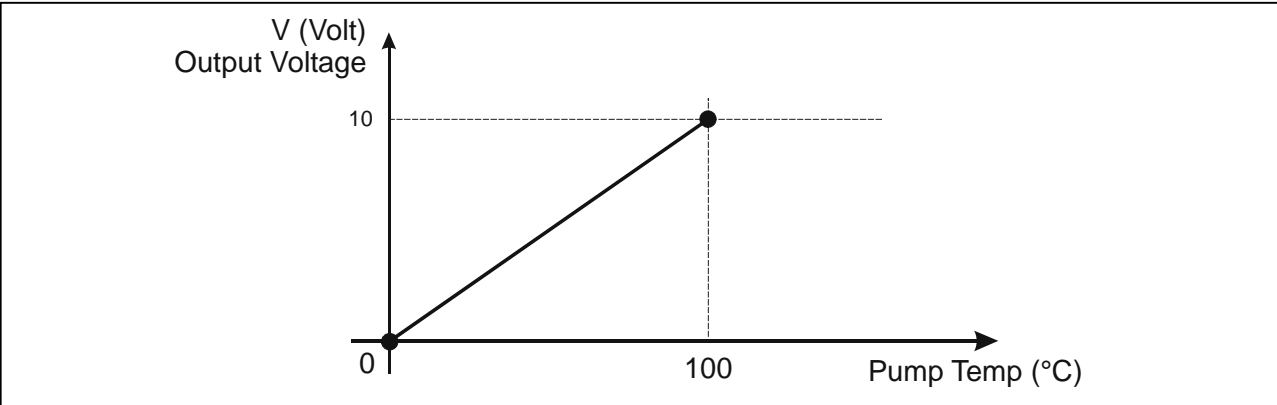
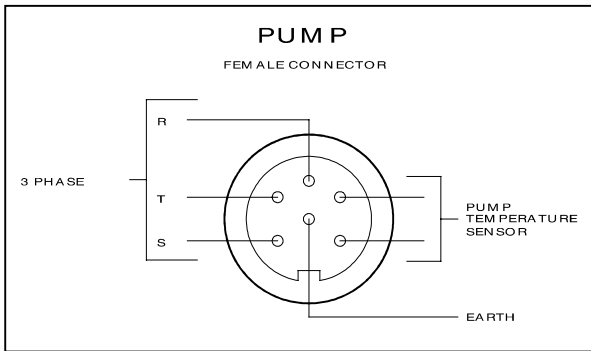

Diagram 3 – Programmable analog output related to pump temperature

Pump Connector

A five-meter long cable is available to connect the controller to the pump. The following figure shows the controller output connector configuration where pins:

- A-F = pump temperature sensor
- B-C-D = 75 Vac 3-phase output to pump motor stator
- E = EARTH PROTECTION



Controller-to-Pump Connector

J5 – GAUGE CONNECTOR

This connector is available to connect “EyeSys Mini-IMG” gauge with its extension cable (see orderable parts table).

The pressure can be read by display or by serial line (win. 224) or by REMOTE I/O on Programmable Analog Out (in this case the controller replicates the signal coming from the gauge).

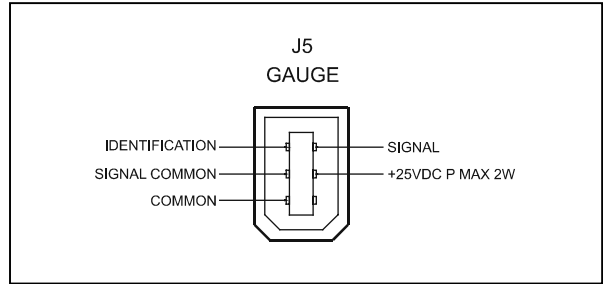

Gauge Connector

NOTE

The Mini-IMG gauge is intended for high vacuum use, so with pressure above 50 mTorr the signal is misinterpreted and a “false” pressure is displayed. Use a transition gauge to understand if the reading is really under 50 mTorr or not.

Pump Driving

Typical pump driving chart start and normal operation.

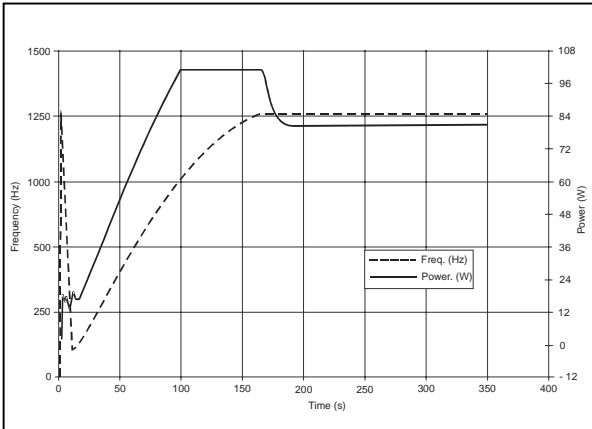

Diagram 4

Stop Speed Reading and Active Stop

This functions can be activated by Front Panel or serial line (Win 107, 167).

Active Stop brakes the pump using the motor. The Stop Speed reading reads the pump speed after a stop command.

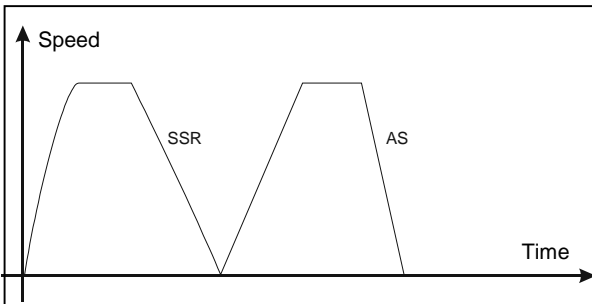
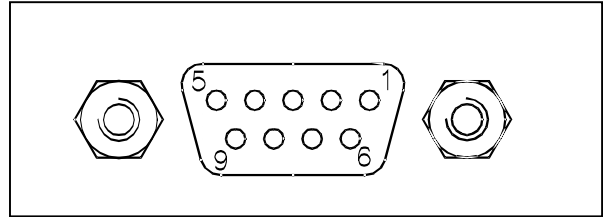

Diagram 5

J2 – SERIAL CONNECTOR

This connector provides the connection for RS – 232 and RS – 485 serial line.

J2 Pin-out:



PIN N.	SIGNAL NAME
1	+5 V (OUT) (Reserved)
2	TX (RS232)
3	RX (RS232)
4	NC
5	GND
6	A + (RS485)
7	NC
8	B – (RS485)
9	RESERVED

Connector examples:

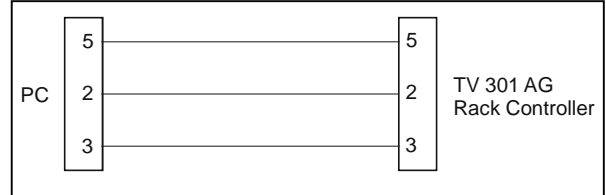

RS – 232 Connection

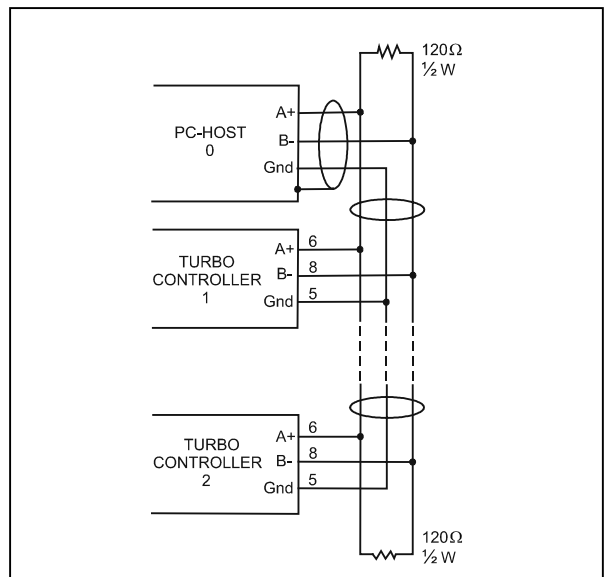

RS – 485 Connection

The communication port mating connector is supplied with the RS 232 PCB (AMP/Cannon or equivalent 15-pin "D" type male connector).

For example, the Transmit data signal from controller (pin 2) must be connected to the host computer's receive data line (pin 2) and vice versa. Consult the host computer's instruction manual for its serial port connections.

NOTE

Varian cannot guarantee compliance with FCC regulations for radiated emissions unless all external wiring is shielded, with the shield being terminated to the metal shroud on the 0-subconnector. The cable should be secured to the connector with screws.

Serial Communication Descriptions

This unit can communicate by two different protocols:

- protocol (old system) "letter"
- "Window" protocol (new system)

These two protocols can be used as well with 232 or 485 media.

NOTE

Please use "Window" protocol for new development.

LETTER PROTOCOL DESCRIPTION:

The default protocol is "Window"

Communication format:

- 8 data bit
- no parity
- 1 stop bit
- The baud rate is programmable via front panel from 600 to 9600 baud. The controller is factory-set for 9600 baud operation.

Communication protocol:

Host = Master

Turbo-V 81-AG Controller = Slave

The communication is performed in the following way:

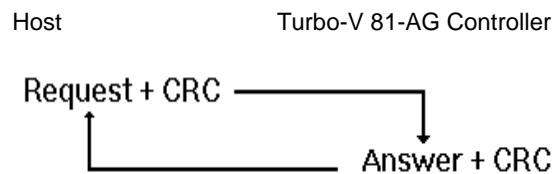

Request is an ASCII character identifying the action that must be performed by the controller or the requested information.

Allowed ASCII characters:

- "A" = START
- "B" = STOP
- "C" = Low Speed ON
- "D" = Low Speed OFF
- "E" = Request for operational parameters
- "F" = Pump times zeroing
- "G" = Parameters reading
- "H" = Parameters writing
- "I" = Request for operating status
- "J" = Request for numerical reading
- "K" = Request for counters reading.

CRC corresponds to the sum (with inverted sign) of all the preceding bytes.

e.g., the START command "A" in ASCII code = 41; inverted it will be: FF + 1 - 41 = BF.

The following parameters can be changed:

BYTES	MEANING
1	Speed threshold
2-5	Run up time in seconds (long coded in 4 bytes)
6	Deat time (0 = NO 1 = YES)
7	Reserved
8	Soft Start mode (0 = YES 1 = NO)
9	CRC

When the **Request** is "I" (Status readings), the **Answer** will contain a string of 2 characters with the following parameters:

BYTES	MEANING
1	<div style="display: flex; justify-content: space-between;"> MSB LSB </div> <div style="margin-top: 10px;"> <p>-- X X X X X X</p> </div>
2	<p>0 = STOP 1 = WAITING INTERLOCK 2 = STARTING 3 = NORMAL OPERATION 4, 5 = HIGH LOAD 6 = FAILURE 7 = APPROACHING LOW SPEED</p> <p>R2 status 0 = OFF 1 = ON R1 status 0 = OFF 1 = ON</p>
2	CRC

When the **Request** is "J" (Numerical readings), the **Answer** will contain a string of 5 characters with the following parameters:

BYTES	MEANING
1	Current (0-255 scaled)
2	Voltage (0-255 scaled)
3	Rotational speed KRPM
4	Pump temperature °C (0-254 temperature reading, 255 = fail)
5	CRC

When the **Request** is "K" (Counters readings), the **Answer** will contain a string of 11 characters with the following parameters:

BYTES	MEANING
1-4	Cycle time
5-8	Pump life
9-10	Cycle number
11	CRC

On request a sample program in QBasic language is available by Varian.

Window Protocol

Description

Communication Format

- 8 data bit
- no parity
- 1 stop bit
- baud rate: 600/1200/2400/4800/9600 programmable

Communication Protocol

The communication protocol is a MASTER/SLAVE type where:

- Host = MASTER
- Controller = SLAVE

The communication is performed in the following way:

1. the host (MASTER) send a MESSAGE + CRC to the controller (SLAVE);
2. the controller answer with an ANSWER + CRC to the host.

The MESSAGE is a string with the following format:

<STX>+<ADDR>+<WIN>+<COM>+<DATA>+<ETX>+<CRC>

where:

NOTE

When a data is indicated between two quotes ('...') it means that the indicated data is the corresponding ASCII character.

- <STX> (Start of transmission) = 0x02
- <ADDR> (Unit address) = 0x80 (for RS 232)
<ADDR> (Unit address) = 0x80 + device number (0 to 31) (for RS 485)
- <WIN> (Window) = a string of 3 numeric character indicating the window number (from '000' to '999'); for the meaning of each window see the relevant paragraph.
- <COM> (Command) = 0x30 to read the window, 0x31 to write into the window
- <DATA> = an alphanumeric ASCII string with the data to be written into the window. In case of a reading command this field is not present. The field length is variable according to the data type as per the following table:

DATA TYPE	FIELD LENGTH	VALID CHARACTERS
Logic (L)	1	'0' = OFF '1' = ON
Numeric (N)	6	'-', '.', '0' ... '9' right justified with '0'
Alphanumeric (A)	10	from blank to '_' (ASCII)

- <ETX> (End of transmission) = 0x03
- <CRC> = XOR of all characters subsequent to <STX> and including the <ETX> terminator. The value is hexadecimal coded and indicated by two ASCII character.

The addressed SLAVE will respond with an ANSWER whose structure depends from the MESSAGE type. When the MESSAGE is a reading command, the SLAVE will respond transmitting a string with the same structure of the MESSAGE.

NOTE

Using the RS 485 interface, the message structure remains identical to the one used for the RS 232 interface, the only difference being that the value assigned to the ADDRESS <ADDR>

The controller can answers with the following response types:

Response Type	Response Length	Response Value	Description
Logic	1 byte	-	after a read instruction of a logic window
Numeric	6 bytes	-	after a read instruction of a numeric window
Alphanumeric	10 bytes	-	after a read instruction of an alphanumeric window
ACK	1 byte	(0x6)	the command execution has been successfully completed
NACK	1 byte	(0x15)	the command execution has been failed
Unknown Window	1 byte	(0x32)	the specified window in the command is not a valid window
Data Type Error	1 byte	(0x33)	the data type specified in the command (Logic, Numeric or Alphanumeric) is not accorded with the specified Window
Out of Range	1 byte	(0x34)	the value expressed during a write command is out of the range value of the specified window
Win Disabled	1 byte	(0x35)	the specified window is Read Only or temporarily disabled (for example you can't write the Soft Start when the Pump is running)

Examples:

Command: START

Source: PC

Destination: Controller

02	80	30	30	30	31	31	03	42	33
STX	ADDR	WINDOW			WR	ON	ETX	CRC	

Source: Controller

Destination: PC

02	80	06	03	38	35
STX	ADDR	ACK	ETX	CRC	

Command: STOP

Source: PC

Destination: Controller

02	80	30	30	30	31	30	03	42	32
STX	ADDR	WINDOW			WR	OFF	ETX	CRC	

Source: Controller

Destination: PC

02	80	06	03	38	35
STX	ADDR	ACK	ETX	CRC	

Command: SOFT-START (ON)

Source: PC

Destination: Controller

02	80	31	30	30	31	31	03	42	32
STX	ADDR	WINDOW			WR	ON	ETX	CRC	

Source: Controller

Destination: PC

02	80	06	03	38	35
STX	ADDR	ACK	ETX	CRC	

Command: SOFT-START (OFF)

Source: PC

Destination: Controller

02	80	31	30	30	31	30	03	42	33
STX	ADDR	WINDOW			WR	OFF	ETX	CRC	

Source: Controller

Destination: PC

02	80	06	03	38	35
STX	ADDR	ACK	ETX	CRC	

Command: READ PUMP STATUS

Source: PC

Destination: Controller (with address = 3)

02	83	32	30	35	30	03	38	37
STX	ADDR	WINDOW			RD	ETX	CRC	

Source: Controller (with address = 3 in stop status)

Destination: PC

02	83	32	30	35	30	30	30	30	30	03	38	37
STX	ADDR	WINDOW	DATA (STATUS)				ETX	CRC				

Command: READ SERIAL TYPE

Source: PC

Destination: Controller (with address = 3 in 485 mode)

02	83	35	30	34	30	03	38	31
STX	ADDR	WINDOW			RD	ETX	CRC	

Source: Controller

Destination: PC

02	83	35	30	34	30	31	03	42	30
STX	ADDR	WINDOW			RD	DATA	ETX	CRC	

Window Meanings

N.	Read/Write	Data Type	Description	Admitted Values
000	R/W	L	Start/Stop (in remote/Front mode the window is a read only)	Start = 1 Stop = 0
001	R/W	L	Low Speed Activation	No = 0 Yes = 1 (default = 0)
008	R/W	L	Remote (default) or Serial configuration	Remote = 1 Serial = 0 (default = 1)
100	R/W	L	Soft Start (write only in Stop condition)	YES = 1 NO = 0
101	R/W	N	R1 Set Point type	0 = Frequency 1 = Power 2 = Time 3 = Normal 4 = Pressure (default = 3)
102	R/W	N	R1 Set Point valve (expressed in Hz, W or s)	(default = 867)
103	R/W	N	Set Point delay: time between the pump start and the set point check (seconds)	0 to 99999 (default = 0)
104	R/W	L	Set Point signal activation type: the signal can be "high level active" or "low level active"	0 = high level active 1 = low level active (default = 0)
105	R/W	N	Set point hysteresis (in % of value)	0 to 100 (default = 2)
106	R/W	L	Water cooling	0 = NO 1 = YES
107	R/W	L	Active Stop (write only in stop)	0 = NO 1 = YES
108	R/W	N	Baud rate	600 = 0 1200 = 1 2400 = 2 4800 = 3 9600 = 4 (default = 4)
109	W	L	Pump life/ cycle time/ cycle number reset	To reset write '1'

TECHNICAL INFORMATION

N.	Read/Write	Data Type	Description	Admitted Values
110	R/W	L	Interlock type (default = 1)	Impulse = 0 Continuous = 1
111	R/W	L	Analog output type: output voltage signal proportional to frequency or power	0 = frequency 1 = power (default = 1) 2 = Pump temperature 3 = Pressure
117	R/W	N	Low Speed frequency (Hz)	1100 to "Maximum rotational frequency" (win 121) (default = 1100)
120	R/W	N	Rotational frequency setting (Hz)	1100 to "Maximum rotational frequency" (win 121) (default = 1350)
122	R/W	L	Set vent valve on/off (on = closed)	On = 1 Off = 0 (default = 1)
123 124	Reserved to Varian service			
125	R/W	L	Set the vent valve operation	Automatic = 0 (see note 1.) On command = 1 (see note 2.)
126	R/W	N	Vent valve opening delay (expressed in 0.2 sec)	0 to 65535 (corresponding to 0 to 13107 sec)
130	Reserved to Varian service			
147	R/W	N	Vent open time See "vent connector" paragraph	0 = infinite 1 bit = 0.2 sec
155	R	N	Power limit applied Read the maximum allowable power	watt
157	R/W	N	Gas load type Select the gas load to the pump	Ø = N ₂ 1 = Av
161	R/W	N	Pressure Reading Connection Factor See "GAUGE CONNECTOR" for more details	0 to 10 0 = 0 10 = 1 = N ₂
162	R/W	A	R1 Set Point Pressure	

N.	Read/Write	Data Type	Description	Admitted Values
			Valve Valid if min. 101 = 4 Format X.X E. XX Where X = 0 to 9 s = + or -	
163	R/W	N	Pressure unit of measure	0 = mBar 1 = Pa 2 = Torr
167	R/W	A	Stop speed reading Activates / deactivates the pump speed reading after Stop command	0 = disable 1 = enable
171	R/W	N	R2 Set Point Type	0 = Freq 1 = Power 2 = Time 3 = Normal 4 = Pressure
172	R/W	N	R2 Set Point Value (Hz, W, s)	
173	R/W	N	R2 Set Point Mask (sec)	
174	R/W	L	R2 Set Point Segnal Activation Type	Ø = high level active 1 = low level active
175	R/W	N	R2 Set front Mysterisis (in % of R2 Valve)	
176	R	A	R2 Set Point Pressure Valve Valid in win 171 = 4 Format X.X E X.X Where: X= 0 to 9 s = + or -	
200	R	N	Pump current in mA dc	
201	R	N	Pump voltage in Vdc	
202	R	N	Pump power in W (pump current x pump voltage duty cycle)	
203	R	N	Driving frequency in Hz	

N.	Read/Write	Data Type	Description	Admitted Values
204	R	N	Pump temperature in °C	0 to 70
205	R	N	Pump status	Stop = 0 Waiting intlk = 1 Starting = 2 Auto-tuning = 3 Braking = 4 Normal = 5 Fail = 6
206	R	N	Error code	Bit description: see the following figure
211	R	N	Controller Heatsink Temperature (°C)	
216	R	N	Controller Air Temperature (°C).	
224	R	A	Pressure reading Format = X.X E XX	
226	R	N	Rotation Frequency (rpm)	
300	R	N	Cycle time in minutes (zeroed by the reset command)	0 to 999999
301	R	N	Cycle number (zeroed by the reset command)	0 to 9999
302	R	N	Pump life in hours (zeroed by the reset command)	0 to 999999
320 to 399	Reserved to Varian service			
400	R	A	CRC EPROM (QE)	QE8XXXX (where "XXXX" are variable)
402	R	A	CRC Param. (PA)	PA8XXXX (where "XXXX" are variable)
404	R	A	CRC Parameter structure	"XXXX"
500	Reserved to Varian service			
503	R/W	N	RS 485 address	0 to 31 (default = 0)
504	R/W	L	Serial type select	0 = RS 232 1 = RS 485 (default = 0)

NOTES

1. Automatic means that when the controller stops, the vent valve is opened with a delay defined by window n. 126; when the controller starts, the vent valve is immediately closed.
2. On command means that the vent valve is opened or closed by means of window n. 122.

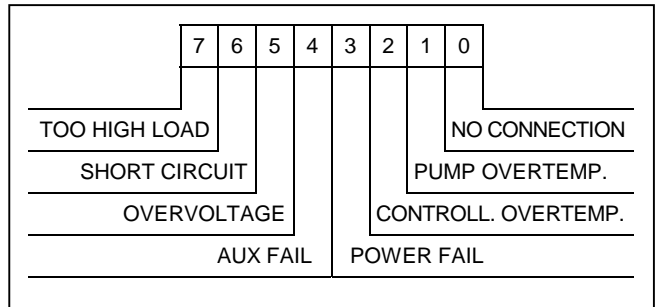

Window N. 206 Bit Description

HOW TO USE BY FRONT PANEL

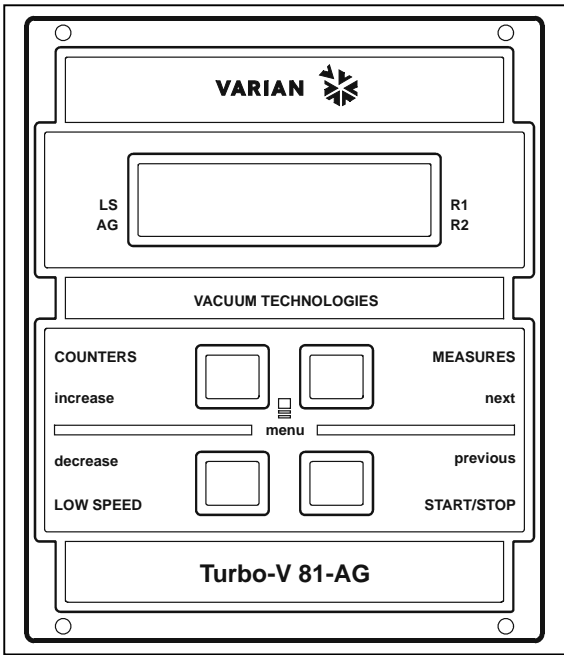

- **Start Stop and Reset Fail button**
Press once for the START command and again for the STOP command.
In the case of controller's failure, press once to reset the fail condition.

NOTE

The front panel START/STOP function is available only if the controller is set to "FRONT mode". If it is set to "REMOTE mode", when the key is pressed an error message is shown indicating "COMMAND LOCKED IN REMOTE", if it is set to "SERIAL" mode, the "COMMAND LOCKED IN SERIAL MODE" error message is displayed.

The "Reset Fail" function is always available regardless of controller mode.

- **Low Speed**
Press once to activate the LOW SPEED command; press again to de-activate.

NOTE

The front panel LOW SPEED function is available only if the controller is set to "FRONT" mode; error message is returned.

If it is set to "REMOTE" mode, the COMMAND LOCKED IN REMOTE error message is displayed while if it is in "SERIAL" mode the "COMMAND LOCKED IN SERIAL MODE" error message is returned.

- **Counters**

Pressing the first time on the display, the following information is displayed:

		C	Y	C	L	E		X	X	X	X		
		T	I	M	E			X	X	X	X	X	m

Where

CYCLE XXXX Number of start/stop cycles
TIME XXXXXm Time of last cycle (minutes)

Pressing a second time, the following is displayed:

		P	U	M	P		L	I	F	E			
		X	X	X	X	X	X	X	X	h			

PUMP LIFE
XXXXXX total operating time (hours) of the pump

Pressing a third time, the following message is displayed:

	M	N	:		X	X	X	X	X	X	X	X	X	X
	S	N	:		Y	Y	Y	Y	Y	Y	Y	Y	Y	Y

MN Model Number of the controller
SN Serial Number

On pressing the key again, the main screen page is redisplayed.

- **Measures**
Pressing once, the following is obtained:

P	=	X	X	X	W				X	X	X	X	H	z
					T	=	X	X	°	C				

Where:

P= XXX W is the current power supplied to the pump

T=XX °C is the current temperature of the pump

XXXX Hz is the current frequency of rotation of the pump. This value is set by default to 1350 Hz but can be modified by the user according to needs, proceeding as described in the "PROGRAMMING" paragraph. The unit of measurement (HZ / Krpm, default = Hz) is selected by the user from the INPUT/OUTPUT->SPED menu.

If the SOFT-START function (PUMP SETTING menu → SOFTSTART is active and the pump is ramping, indication of the speed of rotation is replaced with a bar-graph that indicates the soft-start step in course and the total number of steps to be performed.

On completion of the soft-start ramp, the bar-graph is replaced with indication of the frequency of rotation of the pump

Pressing twice, the following is obtained:

N	O	R	M	A	L				X	X	X	X	H	z			
					I	=	X	.	X	X	A	V	=	X	X	X	V

Where:

NORMAL: indicates the operating regime of the pump

XXXHz: see description "Pressing once" **Measures** key

I=X.XXA: indicates the current absorbed by the pump

V= XXX V: indicates the pump driving voltage

Pressing 3 times, the following is obtained:

P	=	X	X	X	W				X	X	X	X	H	z		
					X	.	X	X	E	-	Y	Y	m	B	a	r

Where:

P= XXXW: indicates the current power supplied to the pump

XXXHz: see description "Pressing once" **Measures** key

x.xxE-yy mbar: indicates the pressure currently measured by the gauge.

Other possible indications:

P	=	X	X	X	W				X	X	X	X	H	z	
					P	R	A	U	G	E	E	R	R	O	R

Where:

GAUGE_ERROR: gauge not connected or broken

P	=	X	X	X	W				X	X	X	X	H	z			
					P	R	E	S	S	U	R	E	U	N	D	E	R

Where:

PRESS UNDER: indicates that the pressure read is below the minimum measurement threshold set (5 E-9 mBar)

P	=	X	X	X	W				X	X	X	X	H	z		
					P	R	E	S	S	U	R	E	O	V	E	R

Where:

PRESS OVER: indicates that the pressure measured is above the maximum measurement threshold set (1000 mBar)

The unit of measurement of the pressure can be selected (GAUGE menu→Unit) from "mBar", "Pa", "torr"

Pressing 4 times returns to the following screen page:

N	O	R	M	A	L					X	X	X	X	H	z
	X	X	X	X	X	X	X	X	X	X	X	X	X	X	

Where:

NORMAL: indicates the operating regime of the pump

XXXHz: see description "Pressing once" **Measures** key

The operating mode of the controller is shown at the bottom in the center. This may be:

FRONT: front mode (the controller accepts START/STOP and LOW SPEED commands from the front panel)

REMOTE: remote mode (the controller accepts START/STOP and LOW SPEED commands via the rear connector)

RS232: the controller accepts commands from the serial port according to the RS232 standard.

RS485 [XX]: the controller accepts commands from the serial port in RS485 mode with address XX (XX from 0 to 31)

PROFIBUS [YYY]: the controller accepts commands from the PROFIBUS port with address YYY

Black rectangles as shown below may be displayed at any time in the first and last box of the bottom line of the display (opposite the LS / AG / R1 / R2 captions). The meaning of these rectangles is as follows:

- LS → the controller is at LOW SPEED
- AG → the Gauge is connected to the controller
- R1 → relay (set point) R1 is active
- R2 → relay (set point) R2 is active

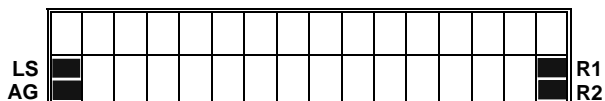

USE

General

Make all vacuum manifold and electrical connections and refer to Turbo-V pump instruction manual before to operating the Turbo-V controller.



WARNING!

To avoid injury to personnel and damage to the equipment, if the pump is laying on a table make sure it is steady. Never operate the Turbo-V pump if the pump inlet is not connected to the system or blanked off.

NOTE

The input signal P1 connector should be left in position including the shipping links if no external connections are made. The forepump and the Turbo-V pump can be switched on at the same time.

Startup

- Plug the controller power cable into a suitable power source.
- The display lights up for approx. 2 seconds and shows:

				A	U	T	O	T	E	S	T	-	-	-
								O	K					

- After 2 seconds, the display shows the following screen page:

S	T	O	P					H	Z
				F	R	O	N	T					

NOTE

If the pump is not connected, the display will be as follows:

C	H	E	C	K		C	O	N	N	E	C	T	I	O	N
				T	O			P	U	M	P				

- Pressing the START button, the pump is started and the display shows the following screen page.

S	T	A	R	T	I	N	G					X	X	X	X	H	Z	
								F	R	O	N	T						

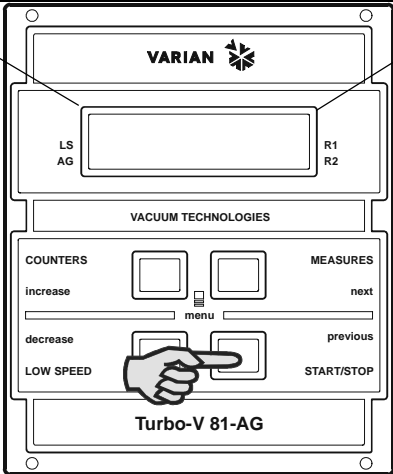

This screen page will be visible throughout the acceleration phase the pump. The increasing value of the rotation frequency will be displayed in the boxes marked X; the user may decide to express this value in Hz (default) or in KRMP.

Once operating speed has been reached, the following screen page is displayed:

N	O	R	M	A	L							1	3	5	0	H	Z
						F	R	O	N	T							

If the LOW SPEED key is pressed, the above screen page changes to:

B	R	A	K	I	N	G						X	X	X	X	H	Z
						F	R	O	N	T							

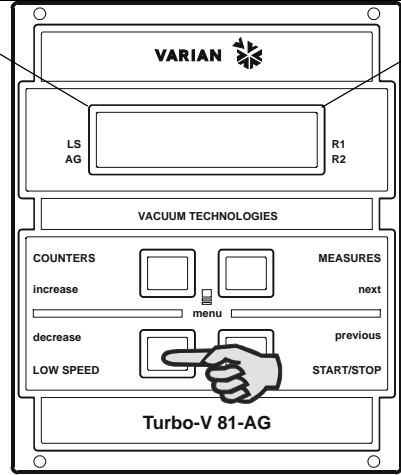

The following screen page is displayed on reaching the pre-established speed:

N	O	R	M	A	L							1	1	0	0	H	Z
						F	R	O	N	T							

The rotation value set in both NORMAL and LOW SPEED mode can be modified by the user as described in the Programming section of this manual.

- Press the MEASURES push button: the display shows:

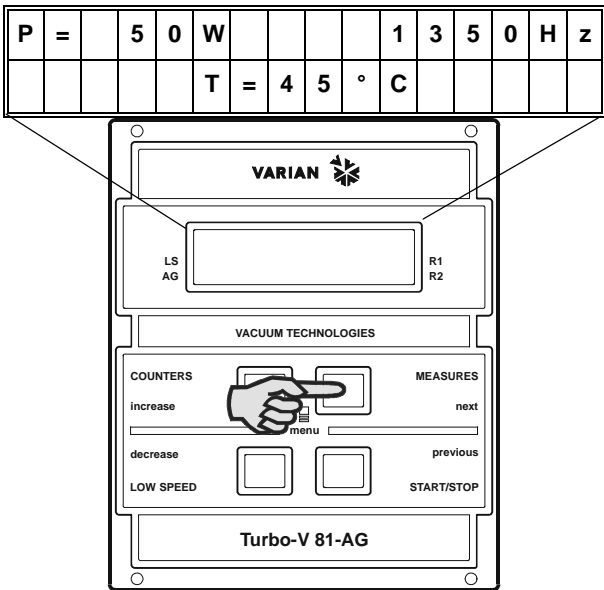

where

P = is the DC power drawn by the pump (range 0 to 999 Watt)

Hz = is the rotational speed of the pump as a function of the controller output frequency

°C = is the temperature of the outer ring of the upper bearing (range 00 to 99 °C)

- Pressing MEASURES key twice, the following screen page is displayed:

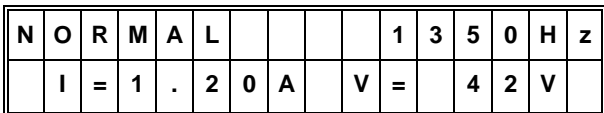

Where:

I is the current supplied by the controller to the pump at that precise moment.

V is the voltage at which the controller is powering the pump at that moment

- Pressing the MEASURES key three times, with the GAUGE connected and functioning, the following screen page is displayed:

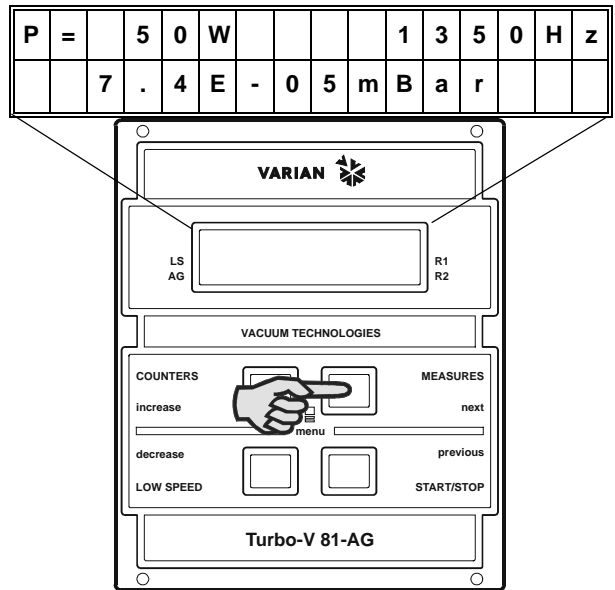

Where:

mBar shows the pressure value measured

The following messages may be displayed instead of the pressure:

GAUGE ERROR: indicates that the GAUGE is not present or is not working

PRESSURE UNDER: indicates that a pressure below the minimum threshold set has been measured (5×10^{-9} mBar)

PRESSURE OVER: indicates that a pressure exceeding the maximum threshold set has been measured (1×10^3 mBar)

Pressing the COUNTERS key, the following is obtained:

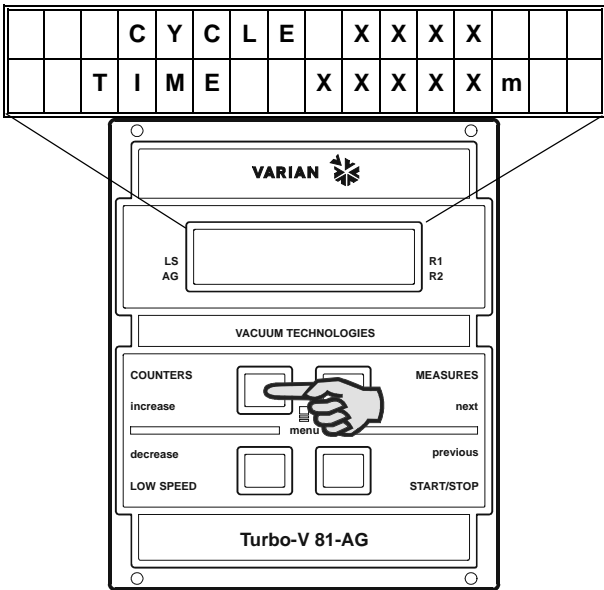

Programming

Configuration menu

To access the configuration menu, press the COUNTERS + MEASURES buttons at the same time for at least 2 sec.

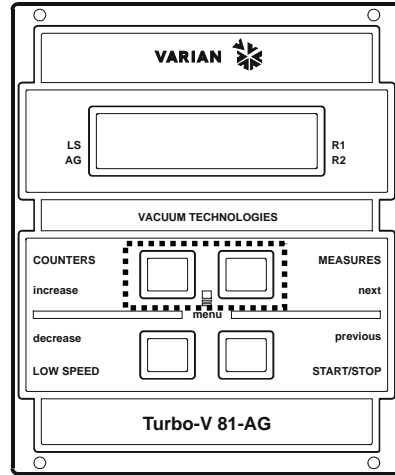

Where

CYCLE XXXX Number of start/stop cycles
TIME XXXXXm Time of last cycle (minutes)

Pressing again:

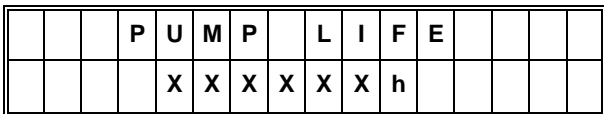

Where:

PUMP LIFE
XXXXXX total operating time (hours) of the pump

In programming mode, the meaning of the 4 buttons changes as follows:

- **COUNTERS/LOW SPEED** become **"INCREASE and DECREASE"** and make it possible to select the next or previous value of a parameter (in the case of compulsory parameters) or to increase/decrease the individual digit of a parameter (in the case of numeric parameters)
- The **"MEASURES and START/STOP"** buttons become **"NEXT and PREVIOUS"** and make it possible to select the next parameter (or next digit of a numeric parameter) or previous parameter.

Switching from one parameter to the next (using the **"NEXT"** key) indicates confirmation of any changes made to the specific parameter. If the changes cannot be accepted by the controller, the **"Data out of limits"** error message is displayed, the changes are cancelled and the value of the parameter prior to the modification is reposed.

Switching from a parameter to the previous parameter (using the “PREVIOUS” key) indicates the intention to abort any changes made to the specific parameter. Abort is indicated by the caption “**Changes aborted**” that is displayed for approx. 1 second before moving to the previous parameter.

The configuration environment has a tree-like structure and permits “circular” navigation; on reaching the end of a branch, the user is returned automatically to the start of this. Navigation can proceed in a forwards (NEXT button) or backwards (PREVIOUS button) direction

It is possible to enter a sub-branch by pressing the “INCREASE” button..

If no buttons are pressed for more than 1 minute, the controller automatically quits the programming environment canceling any modifications made to the current parameter.

The figure below shows the first level of the configuration menu and the links to the respective second level menus (indicated below).

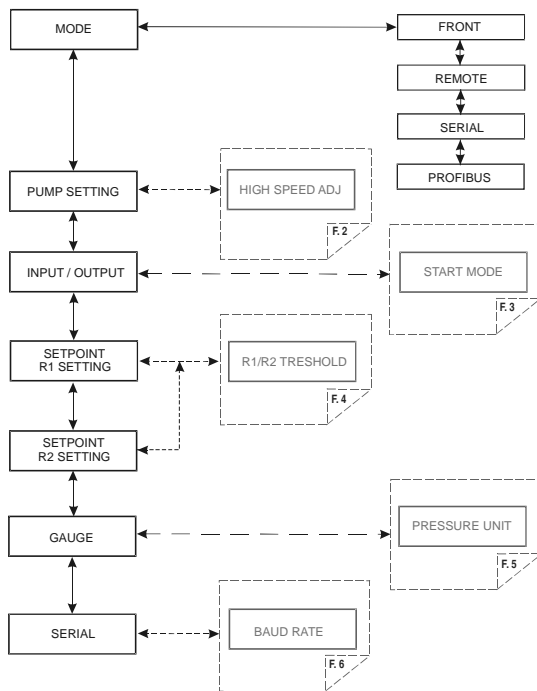

Flow 1/6

Mode menu

- **MODE:** permits selection (see Flow 1/6) of the operating mode of the controller from those indicated below:
 - **FRONT:** accepts commands from the front panel
 - **REMOTE:** accepts commands from the remote input connector
 - **SERIAL:** accepts commands from the serial interface (or Profibus interface if present)
 - **PROFIBUS:** this operating mode is present only if the Profibus interface is installed on the controller

PUMP SETTING menu

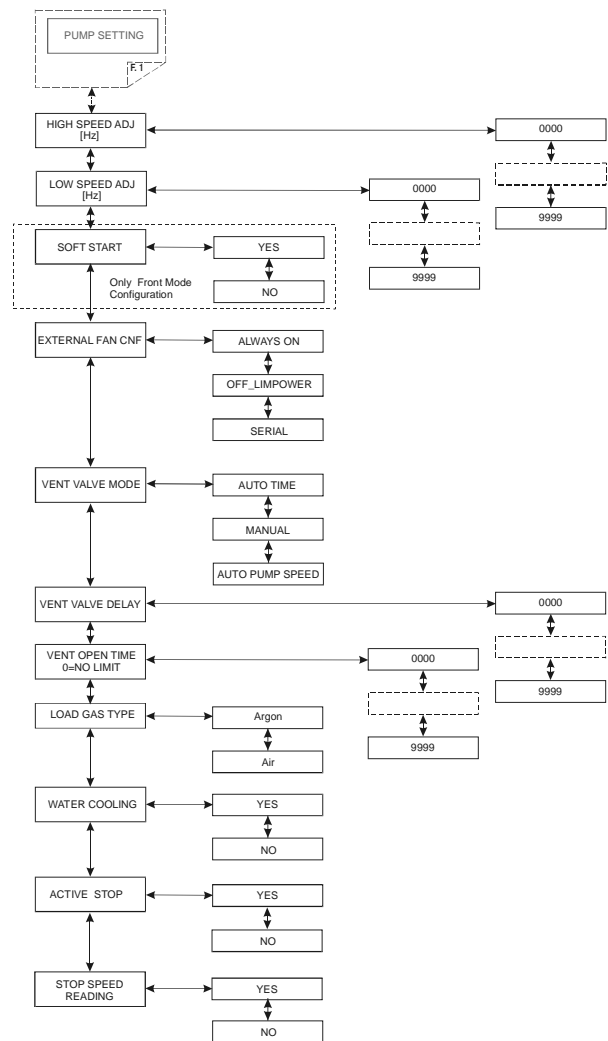

Flow 2/6

This menu contains all the parameters that have a direct effect on driving of the pump.

- **HIGH SPEED:** Sets (in Hz) the speed of rotation of the pump when the low-speed function is not active.
- **LOW SPEED:** Sets (in Hz) the speed of rotation of the pump when the low-speed function is active.
- **SOFT START:** enables (YES) or disables (NO) the soft start function. This parameter is visible only if the controller is configured in FRONT mode.
- **EXTERNAL FAN CNF:** Makes it possible to select driving mode of the external cooling fan. Possible options:
 - **ALWAYS ON:** the cooling fan is always ON
 - **OFF_LIMPOWER:** 10 seconds after the pump has reached NORMAL status, the fan is switched off and the driving power of the pump is reduced to 50 W
 - **SERIAL:** the cooling fan is controlled directly via the serial port.

- **VENT VALVE MODE:** makes it possible to select driving of the vent valve
 - AUTO TIME: the valve is controlled by the controller
 - MANUAL: the valve is controlled by the serial port.
 - AUTO PUMP SPEED: the valve is controlled by the controller its king into account the pump's deceleration.
- **VENT VALVE DELAY:** Sets the delay, expressed in seconds, between stopping of the pump and opening of the vent valve.
- **VENT VALVE OPEN TIME:** sets the time, expressed in seconds, of opening of the vent valve. Enter 0 if the valve is to be kept open indefinitely (until the next start).
- **LOAD GAS TYPE:** selects the type of gas used in the process. Therefore, the controller limits the power supplied to the pump according to the setting of this parameter.
- **WATER COOLING:** indicates whether the pump is cooled with water or not. The controller limits the power supplied to the pump according to this setting.
- **ACTIVE STOP:** enables (YES) or disables (NO) active braking.
- **STOP SPEED READING:** enables (YES) or disables (NO) the pump rotational frequency reading function also during the slowing phase that follows a stop command

- **START MODE:** Permits selection of one of the three types of functioning of the START/STOP and INTERLOCK inputs:
 - START/INTERLOCK: The pump is started if the START/STOP input is activated and is stopped if the START/STOP input is deactivated. The interlock input must be constantly active (INTERLOCK TYPE parameter = continuous) or may be active only at the time of starting (INTERLOCK TYPE parameter = impulsive)
 - START/STOP LEVEL The START/STOP input acts as only START command (active on the level) The INTERLOCK input acts as STOP command (active on the level)
In the case of concurrent activation of the two inputs, the STOP command takes priority
 - START/STOP EDGE The START/STOP input acts as START command (active on the edge) The INTERLOCK input acts as STOP command (active on the edge).
- **INTERLOCK TYPE:** This parameter is displayed only when the previous parameter (START MODE) is equal to START/INTERLOCK and permits selection of one of the following two operating modes of the INTERLOCK input:
 - CONTINUOUS: the INTERLOCK input must be active continuously so that the pump can be driven by the controller. If, with the controller in start, the input INTERLOCK is deactivated, the controller switches to WAITING INTERLOCK status and interrupts driving of the pump
 - IMPULSIVE: it is sufficient for the input to be active when the START command is sent to the pump. Subsequently, the input can also be de-activated. If the interlock is not active when the pump is started, the controller switches too WAITING INTERLOCK status.

INPUT/OUTPUT menu

This menu contains parameters that determine the operating mode of the inputs and outputs of the controller.

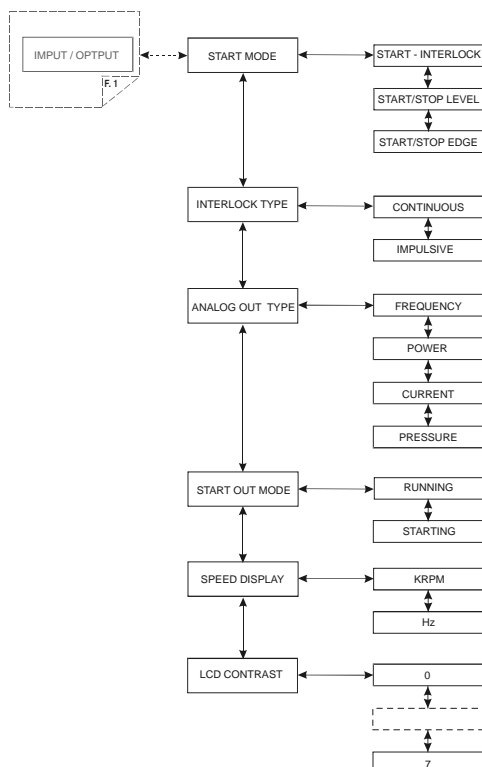

Flow 3/6

- **ANALOG OUT TYPE:** permits selection of the type of signal to be sent to the programmable analogue output. One of the following signals can be selected:
 - FREQUENCY: the drive frequency of the pump is shown
 - POWER: the power supplied to the pump is shown
 - TEMPERATURE: the temperature of the pump is shown
 - PRESSURE: the pressure read by the gauge is shown.
- **START OUT MODE:** Selects the operating mode of the START output. Possible options:
 - RUNNING: the output is active when the pump is driven
 - STARTING: the output is active only during acceleration ramp-up.
- **SPEED OUT MODE (KRPM/Hz):** permits selection of the unit of measurement of the speed of rotation shown on the display of the controller. This setting acts only on the measurement shown on the display. Possible options:
 - KRPM
 - Hz
- **LCD CONTRAST**

SETPOINT R1 and SETPOINT R2 submenus

This submenu contains the settings relating to the output with relay R1 (R2).

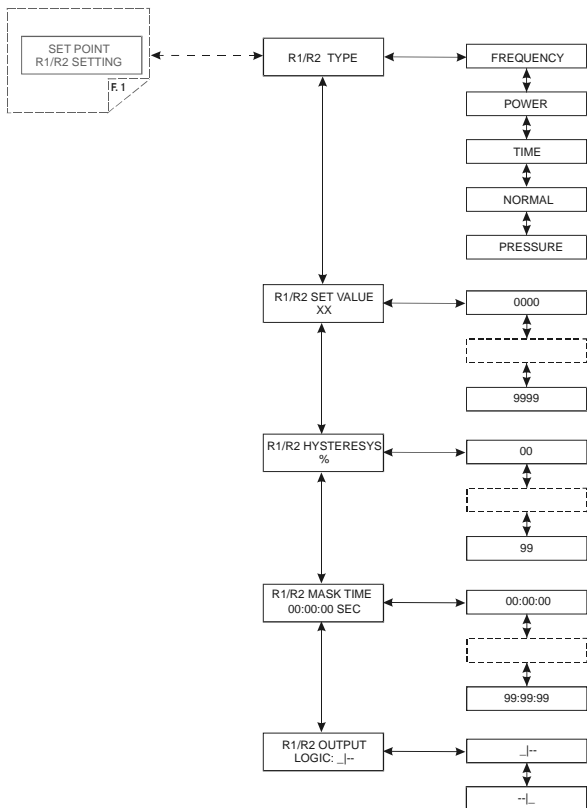

Flow 4/6

- **R1 (R2) TYPE:** selects the type of reference measurement to drive the relay. Possible types:
 - Frequency: driving frequency of the pump
 - Power: power supplied to the pump
 - Time: time from start
 - Normal: achievement of normal condition
 - Pressure: pressure read by the gauge, if present
- **R1 (R2) SET VALUE:** Sets the reference value at which the relay R1 (R2) is activated. This parameter is not available if TIME or NORMAL (previous parameter) is selected as SETPOINT TYPE.
- **R1 (R2) HISTERESYS:** Sets, in percentage, the hysteresis of the relay
- **R1 (R2) MASK TIME:** sets the masked time (in hh:mm:ss), measured from start, within which the SETPOINT R1 (R2) is not driven even if the threshold value has been reached. This parameter is not available if SETPOINT TYPE is set to NORMAL

- **R1 (R2) OUTPUT LOGIC:** Selects the control logic of the SETPOINT output.

|-- positive logic (the relay is energized when the measurement exceeds the reference)

--|_ negative logic (the relay is energized when the measurement is below the reference)

This parameter is not available if SETPOINT TYPE is set to TIME or NORMAL.

GAUGE menu

This menu contains the parameters relating to functioning of the active gauge.

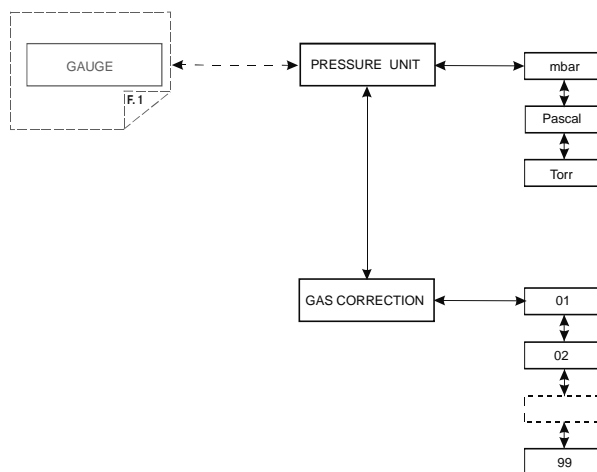

Flow 5/6

- **PRESSURE UNIT:** selects the unit of measurement of the pressure used to show this on the display, for display on the serial line and for setting of the setpoint and autoproessure thresholds. Possible options:
 - mbar
 - Pascal
 - Torr
- **GAS CORRECTION:** sets the conversion factor of the pressure measurement in the case in which the process gas is not nitrogen. The pressure indicated by the instrument is equal to:

$$P \text{ indicated} = P \text{ measured} \times \text{Gas correction} / 10$$

SERIAL menu

This menu contains the settings for management of the RS232/485 serial line.

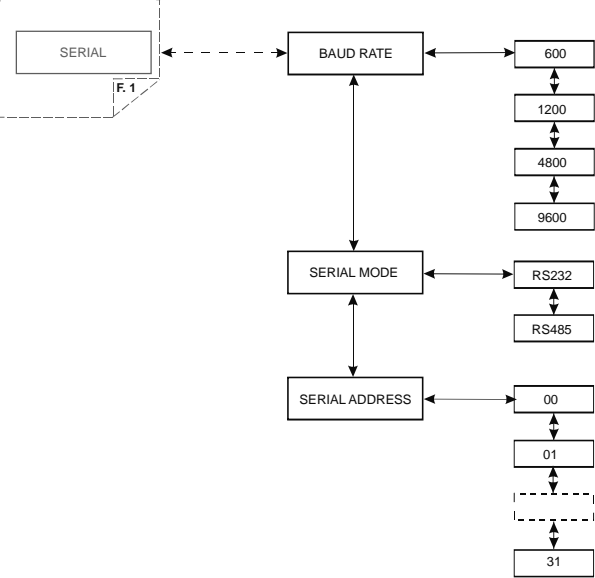

Flow 6/6

- **BAUD RATE:** permits selection of the communication speed selecting this from 600, 1200, 4800, 9600 baud
- **SERIAL MODE:** permits setting of the type of interface to RS232 (point to point) or RS485 (multidrop)
- **SERIAL ADDRESS:** sets the address of the node in the case of the RS485 interface. This parameter is not visible if the RS232 is selected.

HOW TO USE BY REMOTE I/O

1. Power ON the controller
2. Press the "COUNTERS" and "MEASURES" button together.
3. Select MODE = REMOTE from the "INPUT/OUTPUT" menu
4. Exit from configuration menu
5. Connection example:

HOW TO USE IN SERIAL MODE

1. Power on the controller
2. Connect the serial cable
3. Select by front panel if you want to work in 232 or 485, and if necessary, the serial address.
4. Select SERIAL from the INPUT/OUTPUT menu
5. Open the T+ software (see orderable parts table)
6. Ready to operate by SERIAL connections.

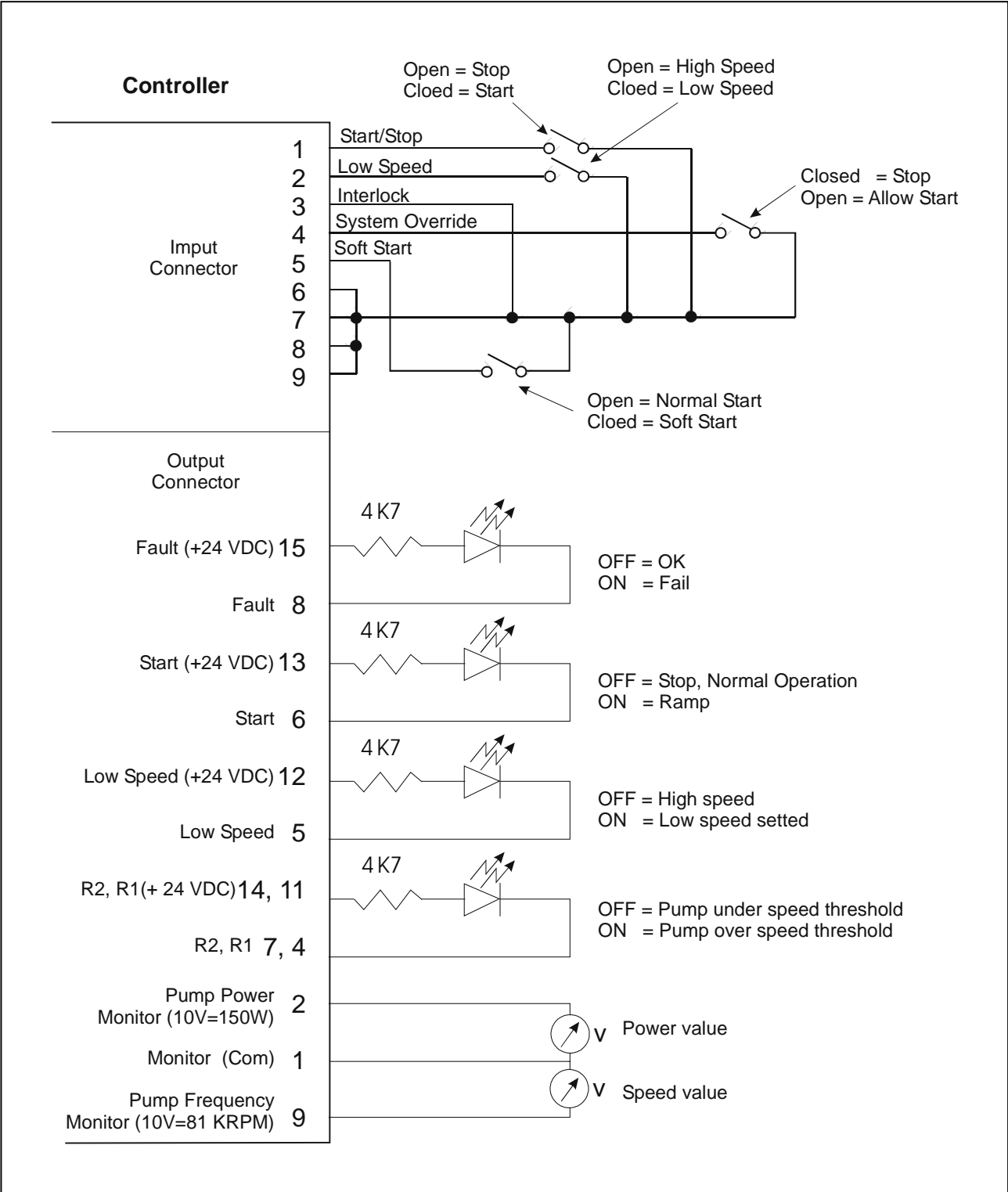

PROFIBUS OPTION

General

The ProfiBus option allow to communicate with the controller as ProfiBus DP slave device.

The option works as a bi-directional bridge between the ProfiBus network and the Varian turbo controller internal link. The interface provides input data (measures) and output data (commands) to the controller, and in addition provides standard and user related diagnostics, in order to allow the user to manage the exceptions.

Installation

This option is factory installed.

The ProfiBus connector pin-out is reported in the following figure. Please in order to obtain best performance use ProfiBus certified cables.

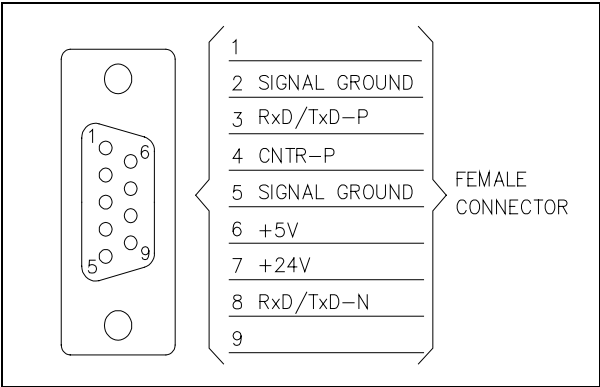

ProfiBus connector

Configuration

Before power-on the controller set the ProfiBus address by the 2 rotary switches.

Up to 126 different addresses (from 0 to 125) can be selected. The address value sets by the 2 switches is expressed in hexadecimal notation, so value from 00 to 7D are permitted; this setting is read by the interface during the power-on phase, so any change of the switch position after the power-on is ignored.

Software operation and state machine

From the software point of view, the interface can be seen as two devices (one for ProfiBus and the other for the internal link) linked together.

Each device has its own state machine to manage the device operation.

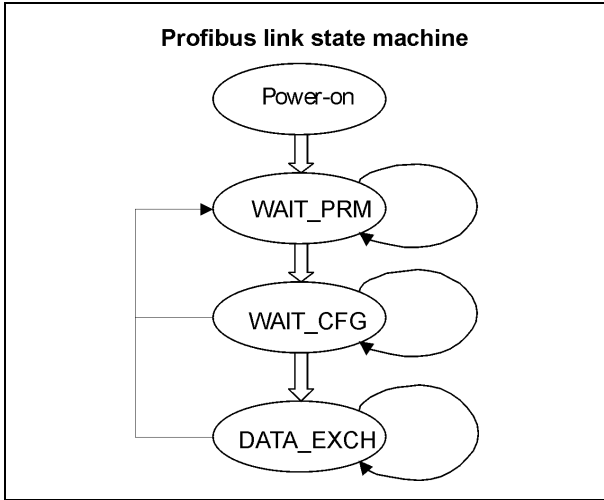

PROFIBUS STATE MACHINE	
Status	Meaning
POWER_ON	Interface set-up
WAIT_PRM	Wait for parameterisation from the master
WAIT_CFG	Wait for configuration from the master
DATA_EX	Regular data exchange

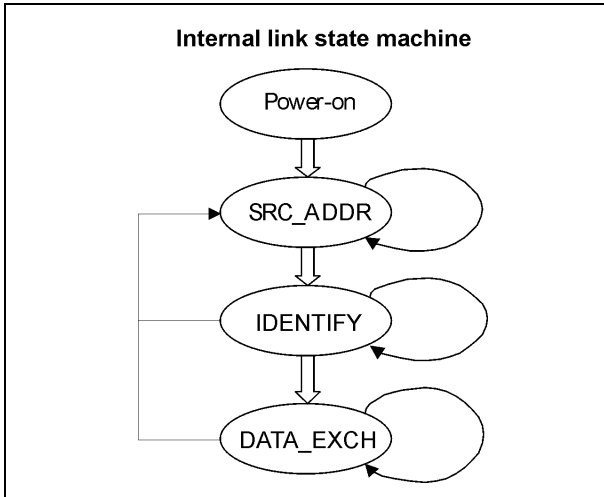

INTERNAL LINK STATE MACHINE	
Status	Meaning
POWER_ON	Interface set-up
SRC_ADDR	Search for the controller serial address
IDENTIFY	Identify controller model and protocol
DATA_EX	Regular data exchange

The two machines continuously share I/O data with the relative bus, and interact each other only in following conditions:

- ProfiBus Data Exchange is suspended (static diagnosis activated) if the internal serial link is not established
- Internal serial link Data Exchange is suspended (only for output data) if the ProfiBus State machine is not in Data Exchange mode

As a general rule, unrecoverable communication errors make each machine to jump to the state immediately following the power-on state (WAIT_PRM or SRC_ADDR)

Message mapping

The communication is based on the continuous data exchange capability of the ProfiBus standard, where the master sends continuously the entire slave configuration and reads back the entire slave status. For this purpose one Input (from slave to master) and one Output (from master to slave) buffers are provided. All the needed parameters are mapped inside each buffer.

The following tables summarise the ProfiBus parameter access, related to the corresponding windows serial protocol (for this protocol please refer to the serial interface paragraph).

The interface doesn't any scaling operation on the read/written parameters. It acts only as a gateway between the ProfiBus network and the pump's controller serial interface. As a consequence of this, the scale and the meaning of some parameters depends directly to the specific model of Turbo Pump controller connected to the interface.

Parameter Buffer

Offset Byte	Size Byte	Unit Res	Range	Description	WIN Serial
0	1	-	0-99	Gauge gas load type The value is divided by 10 (entering 12 the controller will apply 1.2) <i>Enter here the correction factor for gas (necessary only if gauge is connected).</i>	
1	2	mA/Hz/sec	0-10000	Setpoint 1 value <i>Enter here the threshold value for the R1 output, valid only if B₀-B₂ of Parameter Buffer Offset-20 is equal to 0,1,2 or 3.</i>	102
3	2	Sec	0-30000	Setpoint 1 Mask Time <i>Set here the time, measured from the start pump event, while the R1 output is masked (not activated)</i>	103
5	2	mA/Hz/sec	0-10000	Setpoint 2 value <i>Enter here the threshold value for the R2 output, valid only if B₃-B₅ of Parameter Buffer Offset-20 is equal to 0,1,2 or 3.</i>	172
7	2	Sec	0-30000	Setpoint 2 Mask Time <i>Set here the time, measured from the start pump event, while the R2 output is masked (not activated)</i>	173
9	2	0.2sec/bit	0-30000	Vent Valve Opening Delay <i>Set the delay time between the stop command and vent opening. Valid only in "purge/vent auto mode" (Parameter Buffer, Offset 19, B₀ = 0). 0 = infinite (the valve will never open).</i>	126
11	2	0.2sec/bit	0-30000	Vent Valve Open Time <i>Set how long the vent will remain open, then both purge and vent will be closed. Valid only in "purge/vent auto mode" (Parameter Buffer, Offset 19, B₀ = 0). 0 = infinite (the valve remain open till next start command).</i>	147
13	1	%	1-99	Setpoint 1 Hysteresis <i>Set the Setpoint1 hysteresis around the nominal value</i>	105
14	1	%	1-99	Setpoint 2 Hysteresis <i>Set the Setpoint2 hysteresis around the nominal value</i>	175
15	1	mBar/Torr/ Pa	0-99	Setpoint 1 Pressure Value Mantissa <i>Set the mantissa of the exponential value of the R1 setpoint (format X.XE-XX) when it is used for pressure monitoring (Parameter Buffer, Offset 20, B₀₋₂ = 4). The value set here is divided by 10, that means 11 = 1.1</i>	162
16	1		-10 - +10	Setpoint 1 Pressure Value Exponent <i>Set the exponent of the exponential value of the R1 setpoint (format X.XE-XX) when it is used for pressure monitoring (Parameter Buffer, Offset 20, B₀₋₂ = 4).</i>	162
17	1	mBar/Torr/ Pa	0-99	Setpoint 2 Pressure Value Mantissa <i>Set the mantissa of the exponential value of the R2 setpoint (format X.XE-XX) when it is used for pressure monitoring (Parameter Buffer, Offset 20, B₃₋₅ = 4). The value set here is divided by 10, that means 11 = 1.1</i>	176

Offset Byte	Size Byte	Unit Res	Range	Description	WIN Serial
18	1		-10 - +10	Setpoint 2 Pressure Value Exponent <i>Set the exponent of the exponential value of the R2 setpoint (format X.XE-XX) when it is used for pressure monitoring (Parameter Buffer, Offset 20, B₃₋₅ = 4).</i>	176
19	1			B ₀ = Stop Speed Reading <i>This function measures the pump speed after a stop command. 0 = Off 1 = On</i>	167
				B ₁ = Active Stop <i>This function brakes the pump after a stop command, by using the motor as a generator. 0 = Off 1 = On</i>	107
				B ₂ - Reserved	
				B ₃₋₄ = Start/Stop/Interlock Mode <i>Change the logic of Start/Stop and Interlock inputs. Ask to Varian personnel for this option</i>	151
20	1			B ₀ = Vent & Purge Auto/Man <i>0 = Auto (the controller drives purge and vent valves automatically) 1 = Manual (the user can command the valves by serial line or profibus)</i>	125
				B ₁ = Gas Load Type <i>Select here the gas load 0 = Ar 1 = N₂</i>	157
				B ₂ – Interlock Type <i>0 = continuous (the interlock must be always present to run the pump) 1 = at start (the interlock must be present only at start command)</i>	110
				B ₃ = Setpoint R1 Logic <i>0 = active close (NO) 1 = active open (NC)</i>	104
				B ₄ = Setpoint R2 Logic <i>0 = active close (NO) 1 = active open (NC)</i>	174
				B ₅₋₆ = Pressure Unit <i>0 = mbar 1 = Pascal 2 = Torr</i>	163
				B ₇ = Reserved	

Offset Byte	Size Byte	Unit Res	Range	Description	WIN Serial
21	1			B ₀₋₂ = Setpoint R1 Type <i>0 = frequency</i> <i>1 = current</i> <i>2 = time</i> <i>3= normal operation</i> <i>4= pressure</i>	101
				B ₃₋₅ = Setpoint R2 Type <i>0 = frequency</i> <i>1 = current</i> <i>2 = time</i> <i>3= normal operation</i> <i>4= pressure</i>	171
				B ₆₋₇ =Analog Output 1 Type <i>0 = frequency</i> <i>1 = power</i> <i>2 = temperature</i> <i>3= pressure</i>	111

Output Buffer

Offset Byte	Size Byte	Unit Res	Range	Description	WIN Serial
0	1			B ₇ = Start/Stop <i>0 = Stop, 1 = Start</i>	000
				B ₆ = Low Speed <i>This bit set the pump target speed to "low speed value" (Output Buffer, Offset 3), otherwise the target speed is set to "high speed value" (Output Buffer, Offset 1). 0 =Off, 1 =On</i>	001
				B ₅ – Soft Start <i>This bit activates the soft start function which run-up the pump smoothly. Please activate this function only if the pump has been stopped for at least 3 months. 0 = On, 1= Off</i>	100
				B ₄ = Vent Valve Command <i>0 = Close 1 = Open Valid only if in Par Buff, Offset-19, B₀=1</i>	122
				B ₃ = Purge Valve Command <i>0 = Close 1 = Open Valid only if Par Buff, Offset-19, B₀=1</i>	145
				B ₂ – Not used	
				B ₀₋₁ = Operating Mode <i>These bits define from which source the controller has to get commands (readings are always available). In order to operate the controller by Profibus these bits must be set to 3. 0 = Remote I/O 1 = Serial 2 = Front panel 3 = Profibus</i>	008
1	2	Hz	1100 - 1350	High Speed Value <i>Set the high rotational speed value</i>	120
3	2	Hz	1100 - 1350	Low Speed Value <i>Set the low rotational speed value</i>	117

Input Buffer

Offset Byte	Size Byte	Unit Res	Range	Description	WIN Serial
0	1	V	0-100	Voltage <i>Voltage provided to the motor</i>	201
1	1	°C	0-100	Pump Bearing Temperature <i>Read the pump upper bearing temperature If > 60°C the controller goes into fail status and the pump is stopped</i>	204
2	1	°C	0-100	Controller Power Supply Temperature <i>Read the controller power section temperature if > 75°C the controller goes in fail status "controller over-temperature"</i>	216
3	1	°C	0-100	Controller CPU Section Temperature <i>Read the controller CPU section temperature if > 80°C the controller goes in fail "controller over-temperature"</i>	211
4	1	-	0-6	B ₀₋₃ – Status <i>0 = Stop 1= Waiting for interlock (interlock connections on remote I/O connector missing) 2 = Ramp (the pump is increasing the speed) 3 = Auto tuning (the speed has been reduced because the gas load is higher than the Power Limit Applied) 4 = Braking (the pump is reducing the speed using the motor) 5 = Normal operation (the pump is at target speed) 6 = Fail (see error code byte Input Buffer Byte-27)</i>	205
5	1	-	-	Error Code (bit field) B ₇ – Too High Load <i>(the gas load is too high for the pump)</i> B ₆ – Short Circuit <i>(a short circuit happened between the two of the three motor phases)</i> B ₅ – Over Voltage <i>(too high bus voltage during braking)</i> B ₄ – Verify Line Select <i>Not used</i> B ₃ – Power Fail <i>(internal circuitry failure)</i> B ₂ – Controller Over-Temperature <i>("Controller Power Section Temperature" or "Controller CPU Section Temperature" are over the limit)</i> B ₁ - Pump Over-Temperature <i>("Pump Bearing Temperature" or "Pump Body Temperature" are over the limit)</i> B ₀ – Check Connection To Pump <i>(the connection between controller and pump missing)</i>	206

Offset Byte	Size Byte	Unit Res	Range	Description	WIN Serial
6	1	-	-	B ₀ – Set Point R1 Status <i>0 = open</i> <i>1 = closed</i>	221
				B ₁ – Set Point R2 Status <i>0 = open</i> <i>1 = closed</i>	225
				B ₂ – Vent Valve Status <i>0 = closed</i> <i>1 = open</i>	122
				B ₃ – Purge Valve Status <i>0 = close</i> <i>1 = open</i>	145
				B ₄ – Not Used	
				B ₅ – Not Used	
				B ₆ – Not Used	
				B ₇ – Not Used	
7	2	mA	0-10000	Current <i>Motor current consumption</i>	200
9	2	W	0-200	Power <i>Motor power adsorption</i>	201
11	2	W	0-200	Power Limit Applied <i>Maximum allowable power</i>	155
13	2	Hz	0-1500	Driving Frequency <i>Read the rotational speed of the pump</i>	203
15	2	Hz	0-1500	Target Frequency <i>Read the target rotational speed</i>	120
17	2	-	0-65536	Cycle Number <i>Number of cycles (start and stop) done by the pump</i>	301
19	2	min	0-65536	Last Cycle Time <i>How long the last cycle lasted</i>	300
21	2	h	0-65536	Pump Life <i>Total pump running time</i>	302
23	4	mBar/Torr/ Pa	-	Pressure Reading <i>Reports the pressure reading in the “pressure unit” selected by Par. Buff., Offset-19, B₅₋₆</i>	201

Diagnostic management

In addition to the ProfiBus six byte standard diagnostic, the interface provides both user diagnostic and static diagnostics functions

The standard diagnostic management is fully compliant with the ProfiBus specification.

During the start-up phase after power on, the first byte in the user diagnostic area, can assume values different from zero.

This byte has the following meaning:

- Bit 0 = 1: controller not responds (RS485 link broken)
- Bit 1 = 1: controller not identified (not compatible with the ProfiBus gateway)
- Bit 2 = 1: first loop of requests not ended (values in the input data are not fully coherent yet)

So, if the first byte is equal to 0, the interface is working properly, otherwise there is a problem.

Each nibble in the bytes following the interface status byte represents the status of the last attempt to write a parameter with following coding (diag status byte):

- 0 Write success
- 1 Controller response was "NACK"
- 2 Controller response was "Unknown window"
- 3 Controller response was "Bad Data Type"
- 4 Controller response was "Over range"
- 5 Controller response was "Bad operation"
- 6 Controller response was an unknown response
- F Parameter not supported by the controller

The ProfiBus external diagnosis services are used to report following unexpected situations:

- **Controller fail:** if the controller goes in fail mode, an external diagnostic service is required and one byte in the diagnostic buffer signals the type of failure.
- **User parameter mismatch:** if the user sets one or more parameters out of their allowed range, a ProfiBus external diagnostic service is required and some bits in the diagnosis frame signals which parameter is wrong (i.e. over range or under range).

Diagnostic buffer

Off Set	Meaning		
0	B ₀ <i>station non exist</i> (set by master)	Standard diagnostics	
	B ₁ <i>station not ready</i> (slave not ready for data exchange)		
	B ₂ <i>cfg fault</i> (configuration data doesn't match)		
	B ₃ <i>ext diag</i> (slave has external diagnostic data)		
	B ₄ <i>not supported</i> (slave doesn't support requested function)		
	B ₅ <i>invalid slave response</i> (slave sets permanent '0')		
	B ₆ <i>prm fault</i> (wrong parameter assignment)		
	B ₇ <i>master_lock</i> (slave is parameterised by another master)		
1	B ₀ <i>prm req</i> (slave has to be re-parameterised)	Standard diagnostics	
	B ₁ <i>stat diag</i> (static diagnosis)		
	B ₂ fixed '1'		
	B ₃ <i>wd_on</i> (response monitoring active)		
	B ₄ <i>Freeze mode</i> (received freeze command)		
	B ₅ <i>Synch mode</i> (received synch command)		
	B ₆ reserved		
	B ₇ <i>diag deactivated</i> (slave is parameterised by another master)		
2	Reserved		
3	<i>Master Add</i> (master address after parameterisation. FF= without parameter)		
4	Ident number high		
5	Ident number low		
6	External diagnosis "Header" length indication including header		
7	Interface Status	External diagnostic	
	B ₀ Controller not responds		
	B ₁ Controller not identified		
	B ₂ Input data not fully coherent yet		
	B ₃ Not used		
	B ₄₋₇ Not used		
	8		B ₇₋₄ – Start/Stop diag status B ₃₋₀ – Low Speed diag status
	9		B ₇₋₄ – Soft Start diag status B ₃₋₀ – Vent Valve
	10		B ₇₋₄ – Purge Valve B ₃₋₀ – Mode
	11		B ₇₋₄ – High speed B ₃₋₀ – Low Speed

ERROR MESSAGES

For a certain type of failure, the controller will self-diagnose the error and the following messages will be displayed.

NOTE

If the pump is not connected, the display will be as shown in the following figure.

C	H	E	C	K		C	O	N	N	E	C	T	I	O	N
				T	O			P	U	M	P				

Check connection between controller and pump, then press STOP push-button twice to start the pump.

NOTE

If the P1 input connector is not in position with the link or the external interlock connections are open, when the START pushbutton is pressed the display will be as shown in the following figure.

				W	A	I	T	I	N	G				
				I	N	T	E	R	L	O	C	K		

Disconnect connector P1 and check the link or the external interlock, then install the connector to start the pump.

NOTE

If within each step of the soft start mode the rotational speed of the pump do not reach the planned value within 15 minutes the display will be as shown in the following figure.

NOTE

If in normal operation (after the starting phase) the current drawn by the pump is higher than programmed (1.8 A), the pump and the inter-connected devices are switched off and the display will be as shown in the following figure.

	T	O	O		H	I	G	H		L	O	A	D	

Verify that systems has no leaks than press STOP RESET pushbutton twice to start the pump.

Check that pump rotor is free to rotate then press the STOP RESET pushbutton twice to start the pump.

NOTE

If the upper bearing/pump temperature exceeds 60 °C, the pump is shut off, and the display will be as shown in the following figure.

						P	U	M	P					
				O	V	E	R	T	E	M	P			

The message will stay on until the temperature decreases below threshold value. Press the STOP RESET pushbutton twice to start the pump.

NOTE

If the controller transformer temperature exceeds 90°C, the pump is shut off, and the display will be as shown in the following figure.

			C	O	N	T	R	O	L	L	E	R		
			O	V	E	R	T	E	M	P				

The message will stay on until the temperature decreases below threshold value. Press the STOP RESET pushbutton twice to start the pump.

			P	O	W	E	R		F	A	I	L		

Indicates a fault in the circuit of the controller used to power the pump.

NOTE

If the pump is stopped by an emergency stop signal provided via a remote contact, the display will be as shown in the following figure.

			S	Y	S	T	E	M					
			O	V	E	R	R	I	D	E			

Remove the controller power cable and check the emergency condition.

Then reconnect the power cable and press the START pushbutton to start the pump.

Controller power supply circuitry is faulty, or the Controller received a spike.

Press the START push-button twice to start the pump.
Should the message still be present, call the Varian service.

Check connections and shortages between pump and controller, then press the STOP RESET pushbutton twice to start the pump.

ORDERABLE PARTS

DESCRIPTION	PART NUMBER
Turbo-V 81-AG	969-8988
Turbo-V 81-AG with RS-232/485 option	969-8989
Turbo-V 81-AG with Profibus option	969-8990
Turbo-V 81-AG Air Cooling Kit (0.5 m cable)	969-9290
Turbo-V 81-AG Air Cooling Kit extension cable (5 m)	969-9940
Vent Valve N.O. 0,5 mm orifice (0,5 m cable)	969-9844
Vent Valve extension cable (5 m)	969-9941
EyeSys Mini-IMG Gauge cable (1 m)	969-9943
EyeSys Mini-IMG Gauge (special)	R1400301**** (not yet available)
Gauge extension cable (5 m)	969-9944
Mains cable NEMA plug (3 m)	969-9958
Mains cable european plug (3 m)	969-9957



Request for Return



1. A Return Authorization Number (RA#) **WILL NOT** be issued until this Request for Return is completely filled out, signed and returned to Varian Customer Service.
2. Return shipments shall be made in compliance with local and international **Shipping Regulations** (IATA, DOT, UN).
3. The customer is expected to take the following actions to ensure the **Safety** of workers at Varian: (a) Drain any oils or other liquids, (b) Purge or flush all gasses, (c) Wipe off any excess residues in or on the equipment, (d) Package the equipment to prevent shipping damage, (for Advance Exchanges please use packing material from replacement unit).
4. Make sure the shipping documents clearly show the RA# and then return the package to the Varian location nearest you.

North and South America

Varian Vacuum Technologies
 121 Hartwell Ave
 Lexington, MA 02421
 Phone : +1 781 8617200
 Fax: +1 781 8609252

Europe and Middle East

Varian SpA
 Via Flli Varian 54
 10040 Leini (TO) – ITALY
 Phone: +39 011 9979111
 Fax: +39 011 9979330

Asia and ROW

Varian Vacuum Technologies
 Local Office

CUSTOMER INFORMATION

Company name:	
Contact person: Name:	Tel:
Fax:	E-Mail:
Ship Method:	Shipping Collect #: P.O.#:
<i>Europe only:</i> VAT reg. Number:	<i>USA only:</i> <input type="checkbox"/> Taxable <input type="checkbox"/> Non-taxable
Customer Ship To:	Customer Bill To:
.....
.....

PRODUCT IDENTIFICATION

Product Description	Varian P/N	Varian S/N	Purchase Reference

TYPE OF RETURN (check appropriate box)

<input type="checkbox"/> Paid Exchange	<input type="checkbox"/> Paid Repair	<input type="checkbox"/> Warranty Exchange	<input type="checkbox"/> Warranty Repair	<input type="checkbox"/> Loaner Return
<input type="checkbox"/> Credit	<input type="checkbox"/> Shipping Error	<input type="checkbox"/> Evaluation Return	<input type="checkbox"/> Calibration	<input type="checkbox"/> Other

HEALTH and SAFETY CERTIFICATION

Varian Vacuum Technologies **CAN NOT ACCEPT** any equipment which contains **BIOLOGICAL HAZARDS** or **RADIOACTIVITY**. Call Varian Customer Service to discuss alternatives if this requirement presents a problem.

The equipment listed above (check one):

HAS NOT been exposed to any toxic or hazardous materials

OR

HAS been exposed to any toxic or hazardous materials. In case of this selection, check boxes for any materials that equipment was exposed to, check all categories that apply:

Toxic Corrosive Reactive Flammable Explosive Biological Radioactive

List all toxic or hazardous materials. Include product name, chemical name and chemical symbol or formula.

.....

Print Name: Customer Authorized Signature:

Print Title: Date:/...../.....

NOTE: If a product is received at Varian which is contaminated with a toxic or hazardous material that was not disclosed, **the customer will be held responsible** for all costs incurred to ensure the safe handling of the product, and **is liable** for any harm or injury to Varian employees as well as to any third party occurring as a result of exposure to toxic or hazardous materials present in the product.

Do not write below this line

Notification (RA)#: Customer ID#: Equipment #:

FAILURE REPORT

TURBO PUMPS and TURBOCONTROLLERS

<input type="checkbox"/> Does not start <input type="checkbox"/> Does not spin freely <input type="checkbox"/> Does not reach full speed <input type="checkbox"/> Mechanical Contact <input type="checkbox"/> Cooling defective	<input type="checkbox"/> Noise <input type="checkbox"/> Vibrations <input type="checkbox"/> Leak <input type="checkbox"/> Overtemperature	POSITION <input type="checkbox"/> Vertical <input type="checkbox"/> Horizontal <input type="checkbox"/> Upside-down <input type="checkbox"/> Other:	PARAMETERS Power: Rotational Speed: Current: Inlet Pressure: Temp 1: Foreline Pressure: Temp 2: Purge flow:
TURBOCONTROLLER ERROR MESSAGE:			OPERATION TIME:

ION PUMPS/CONTROLLERS

<input type="checkbox"/> Bad feedthrough <input type="checkbox"/> Vacuum leak <input type="checkbox"/> Error code on display	<input type="checkbox"/> Poor vacuum <input type="checkbox"/> High voltage problem <input type="checkbox"/> Other
Customer application:	

VALVES/COMPONENTS

<input type="checkbox"/> Main seal leak <input type="checkbox"/> Solenoid failure <input type="checkbox"/> Damaged sealing area	<input type="checkbox"/> Bellows leak <input type="checkbox"/> Damaged flange <input type="checkbox"/> Other
Customer application:	

LEAK DETECTORS

<input type="checkbox"/> Cannot calibrate <input type="checkbox"/> Vacuum system unstable <input type="checkbox"/> Failed to start	<input type="checkbox"/> No zero/high background <input type="checkbox"/> Cannot reach test mode <input type="checkbox"/> Other
Customer application:	

INSTRUMENTS

<input type="checkbox"/> Gauge tube not working <input type="checkbox"/> Communication failure <input type="checkbox"/> Error code on display	<input type="checkbox"/> Display problem <input type="checkbox"/> Degas not working <input type="checkbox"/> Other
Customer application:	

PRIMARY PUMPS

<input type="checkbox"/> Pump doesn't start <input type="checkbox"/> Doesn't reach vacuum <input type="checkbox"/> Pump seized	<input type="checkbox"/> Noisy pump (describe) <input type="checkbox"/> Over temperature <input type="checkbox"/> Other
Customer application:	

DIFFUSION PUMPS

<input type="checkbox"/> Heater failure <input type="checkbox"/> Doesn't reach vacuum <input type="checkbox"/> Vacuum leak	<input type="checkbox"/> Electrical problem <input type="checkbox"/> Cooling coil damage <input type="checkbox"/> Other
Customer application:	

FAILURE DESCRIPTION

(Please describe in detail the nature of the malfunction to assist us in performing failure analysis):

NOTA: Su richiesta questo documento è disponibile anche in Tedesco, Italiano e Francese.
REMARQUE : Sur demande ce document est également disponible en allemand, italien et français.
HINWEIS: Auf Anfrage ist diese Unterlage auch auf Deutsch, Italienisch und Französisch erhältlich.

Sales and Service Offices

France and Benelux

Varian s.a.

7 Avenue des Tropiques
Z.A. de Courtaboeuf - B.P. 12
Les Ulis cedex (Orsay) 91941
France
Tel: (33) 1 69 86 38 84
Fax: (33) 1 69 86 29 88
From Benelux Tel: (31) 118 67 15 70
From Benelux Fax: (31) 118 67 15 69

Canada

Central coordination through:

Varian Vacuum Technologies

121 Hartwell Avenue
Lexington, MA 02421
USA
Tel: (781) 861 7200
Fax: (781) 860 5437
Toll Free # 1 (800) 882 7426

China

Varian Technologies - Beijing

Rm 1648 Central Tower South Wing
Beijing Junefield Plaza
No. 10 XuanWuMenWai Street
Beijing 100052
P.R. China
Tel: (86) 10 63108550
Fax: (86) 10 63100141
Toll Free: 800 820 6556

Germany and Austria

Varian Deutschland GmbH

Alsfelder Strasse 6
Postfach 11 14 35
64289 Darmstadt
Germany
Tel: (49) 6151 703 353
Fax: (49) 6151 703 302

India

Varian India PVT LTD

101-108, 1st Floor
1010 Competent House
7, Nangal Raya Business Centre
New Delhi 110 046
India
Tel: (91) 11 28521171
Fax: (91) 11 28521173

Italy

Varian Inc.

Vacuum Technologies

Via F.lli Varian 54
10040 Leini, (Torino)
Italy
Tel: (39) 011 997 9 111
Fax: (39) 011 997 9 350

Japan

Varian Vacuum Technologies

Sumitomo Shibaura Building, 8th Floor
4-16-36 Shibaura
Minato-ku, Tokyo 108
Japan
Tel: (81) 3 5232 1253
Fax: (81) 3 5232 1263
Toll Free: 0120 655 040

Korea

Varian Technologies Korea, Ltd

Shinsa 2nd Bldg. 2F
966-5 Daechi-dong
Kangnam-gu, Seoul
Korea 135-280
Tel: (82) 2 3452 2452
Fax: (82) 2 3452 2451
Toll Free: 080 222 2452

Mexico

Varian, S. de R.L. de C.V.

Concepcion Beistegui No 109
Col Del Valle
C.P. 03100
Mexico, D.F.
Tel: (52) 5 523 9465
Fax: (52) 5 523 9472

Taiwan

Varian Technologies Asia Ltd.

14F-6, No.77, Hsin Tai Wu Rd., Sec. 1
Hsi chih, Taipei Hsien
Taiwan, R.O.C.
Tel: (886) 2 2698 9555
Fax: (886) 2 2698 9678
Toll Free: 0800 051342

UK and Ireland

Varian Ltd.

6 Mead Road
Oxford Industrial Park - Yarnton
Oxford OX5 1QU - England
Tel: (44) 1865 291570
Fax: (44) 1865 291571

United States

Varian Vacuum Technologies

121 Hartwell Avenue
Lexington, MA 02421
USA
Tel: (781) 861 7200
Fax: (781) 860 5437

Other Countries

Varian Inc.

Vacuum Technologies

Via F.lli Varian 54
10040 Leini, (Torino)
Italy
Tel: (39) 011 997 9 111
Fax: (39) 011 997 9 350

Customer Support & Service:

North America

Toll-Free: 1 800 882 7426
vtl.technical.support@varianinc.com

Europe

Tel: 00 800 234 234 00
vtt.technical.support@varianinc.com

China

Toll-Free: 800 820 8266
vtc.technical.support@varianinc.com

Japan

Toll-Free: 0120 655 040
vtj.technical.support@varianinc.com

Korea

Toll-Free: 080 222 2452
vtk.technical.support@varianinc.com

Taiwan

Toll-Free: 0 800 051 342
vtw.technical.support@varianinc.com

Worldwide Web Site, Catalog and Order On-line:

www.varianinc.com

Representative in most countries

