

Thermo Scientific
Accel Series
Cooling/Heating
Recirculating Chillers

Thermo Scientific Manual P/N U01076 Rev. 05/01/2013

Installation
Operation



Visit our Web site at:

<http://www.thermoscientific.com/tc>
Product Service Information, Applications
Notes, MSDS Forms, e-mail.

Voice Info: (800) 258-0830

Thermo Fisher Scientific

25 Nimble Hill Road
Newington, NH 03801
Tel : (800) 258-0830 or
(603) 436-9444
Fax : (603) 436-8411
www.thermoscientific.com/tc

Sales, Service, and Customer Support

25 Nimble Hill Road
Newington, NH 03801
Tel: (800) 258-0830
Sales: 8:00 am to 5:00 pm
Service and Support: 8:00 am to 6:00 pm
Monday through Friday (Eastern Time)
Fax: (603) 436-8411
service.tc.us@thermofisher.com

Dieselstrasse 4
D-76227 Karlsruhe, Germany
Tel : +49 (0) 721 4094 444
Fax : +49 (0) 721 4094 300
info.tc.de@thermofisher.com

Building 6, No. 27
Xin Jinqiao Rd., Shanghai 201206
Tel : +86(21) 68654588
Fax : +86(21) 64457830
info.china@thermofisher.com

Stafford House
1 Boundary Park
Hemel Hempstead, Hertfordshire HP2 7GE
United Kingdom
Phone: +44 (0)8706 099254
Fax: +44 (0)1606 548103

Statement of Copyright

Copyright © 2013 Thermo Fisher Scientific. All rights reserved.

This manual is copyrighted by Thermo Fisher Scientific.

Users are forbidden to reproduce, republish, redistribute, or resell any materials from this manual in either machine-readable form or any other form.

Table of Contents

Quick Start

Preface	i
Compliance	i
After-Sale Support	i
Feedback.....	i
Warranty	i
Unpacking.....	i
Contact Information	ii

Section 1 Safety	1-1
Safety Warnings.....	1-1

Section 2 General Information	2-1
Description and Intended Use.....	2-1
Specifications	2-1
Equipment Ratings	2-4
Approved Fluids.....	2-4
Wetted Materials.....	2-4

Section 3 Installation	3-1
Ventilation.....	3-1
Electrical Requirements	3-1
Plumbing Requirements.....	3-2
Fluid Considerations	3-3
Approved Fluids.....	3-4
Filling Requirements	3-6
Draining.....	3-7
Shipping/Storage	3-7

Section 4 Operation	4-1
Controller	4-1
Setup	4-2
Start Up	4-2
Status Display	4-3
Stand By Mode.....	4-3
Stopping the Chiller.....	4-3
Power Down.....	4-3
Shut Down.....	4-3

	Restarting	4-3
	Changing the Setpoint.....	4-4
	Menu Displays.....	4-5
	Menu.....	4-5
	Menu Tree.....	4-6
	Settings	4-7
	System.....	4-12
	High Temperature Cutout.....	4-15
Section 5	Preventive Maintenance.....	5-1
	Cleaning	5-1
	Condenser.....	5-1
	Fluid Maintenance	5-1
	Sight Tube.....	5-1
	Testing the Safety Features.....	5-1
	Decommissioning/Disposal.....	5-2
Section 6	Troubleshooting.....	6-1
	Error Displays.....	6-1
	Check List.....	6-3
Appendix	AC Serial Communications Protocol.....	A-1
	Declaration of Conformity	
	RoHS Directive	
	Warranty	

Safety Precautions:

- The chiller is designed for indoor use only.
- Never place chiller in a location where excessive heat, moisture, inadequate ventilation, or corrosive materials are present.
- Never use flammable or corrosive fluids with this chiller.
- Never connect process fluid lines to your facility water supply or to any pressurized liquid source.
- Before using any fluid or performing maintenance where contact with the fluid is likely refer to the manufacturer's MSDS for handling precautions.

What you need to get started:

- An adjustable wrench
- Appropriate hose or plumbing
- Appropriate size clamps or connection type

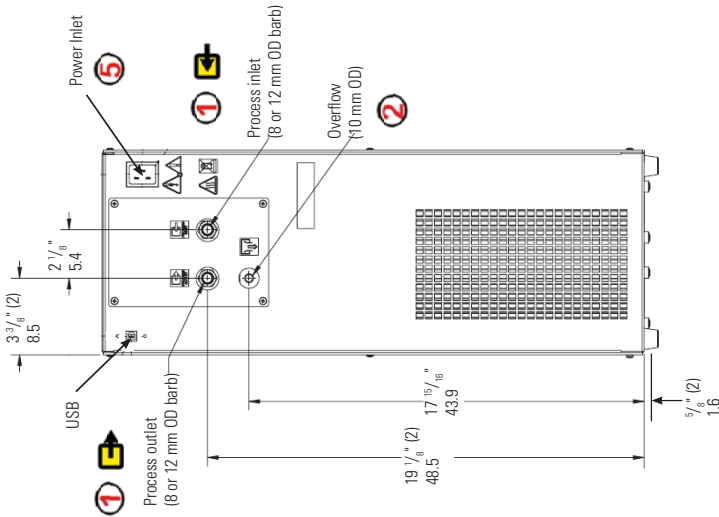

1 Ensure that all shipping plugs are removed before installation.

The process fluid connections are located on the rear of the chiller and are labeled PROCESS OUTLET and PROCESS INLET.

Connect the PROCESS OUTLET to the fluid inlet on your application. Connect the PROCESS INLET to the fluid outlet on your application. Ensure all connections are secure.

Keep the distance between the chiller and the instrument being cooled as short as possible. To minimize back pressure, ensure tubing is as straight as possible. If diameter reductions are required, make them at the inlet and outlet of your application, not at the chiller.

2 Ensure the reservoir overflow located on the rear of the chiller is connected to a suitable drain.



To prevent damage to the chiller's plumbing, use a 19 mm backing wrench when removing/installing the external connections. ▲

Table 1 - Acceptable Fluids:

Use of any fluid not listed below will void the manufacturer's warranty.
 5°C to 80°C — Distilled Water or Deionized Water (up to 3 MΩ-cm)
 -10°C to 80°C — 50/50 Water with Glycol

- 3 Lift up on the fill panel on the front of the chiller to remove it. Start with 2.8 liters of fluid.
- Insert the supplied funnel into the hose and slowly add fluid. Due to the chiller's plumbing configuration, adding fluid too quickly may result in overflowing - the fill level indication lags the actual amount added.

When pouring fluid into the funnel ensure the fluid contacts the side of the funnel first, A. Pouring the fluid into the center of the funnel, B, will cause air pockets and substantially slow down the filling time.

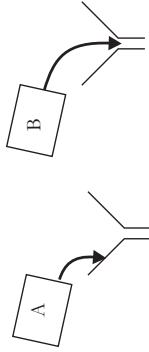
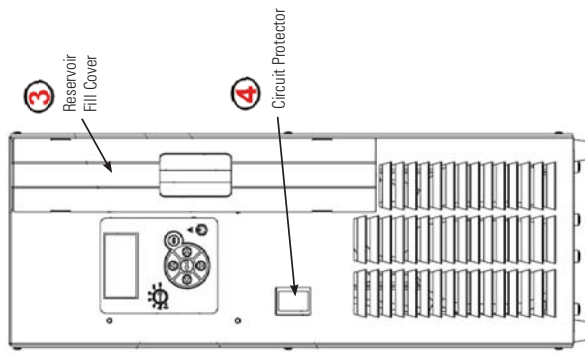

Using the fill lines, verify the desired fluid level.



Since the reservoir capacity may be small compared to your application and air may need to be purged from the lines, have extra cooling fluid on hand to keep the system topped off when external circulation is started.

Avoid overfilling, fluids expand when heated.

- 4 Ensure the circuit protector to the off (O) position.
- 5 Verify the appropriate voltage. For chillers supplied with a line cord, insert female end of power cord into chiller and then insert male end of power cord into power outlet. (The line cord is located under the shipping crate's lid. Do not discard the lid until the cord is located.)

Start Up

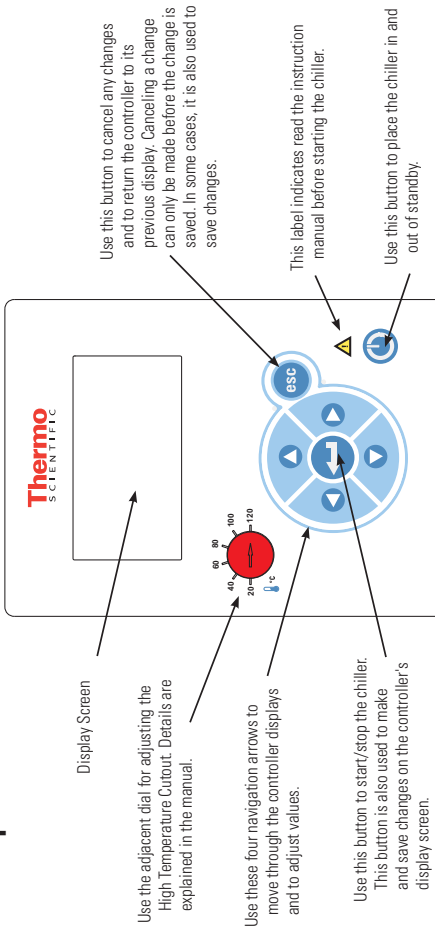



- Use the adjacent dial for adjusting the High Temperature Cutout. Details are explained in the manual.
- Use these four navigation arrows to move through the controller displays and to adjust values.
- Use this button to start/stop the chiller. This button is also used to make and save changes on the controller's display screen.
- Use this button to cancel any changes and to return the controller to its previous display. Canceling a change can only be made before the change is saved. In some cases, it is also used to save changes.
- This label indicates read the instruction manual before starting the chiller.
- Use this button to place the chiller in and out of standby.

Chillers should be left in an upright position at room temperature (~25°C) for 24 hours before starting. This will ensure the lubrication oil has drained back into the compressor.

Before starting, double check all USB, electrical and plumbing connections.

Do not run the chiller until fluid is added to the reservoir. Have extra fluid on hand. If the chiller will not start refer to the manual.

- Place the circuit protector located on the front of the chiller to the **I** position.
- Press , the Start Display will appear.
- Ensure the start symbol has a highlight box around it, if not use the arrow keys to navigate to the symbol.
- Press . The chiller will start and the start symbol will turn into a stop symbol ().

It may take 30 seconds for the compressor to start.

After start, check all external plumbing connections for leaks.

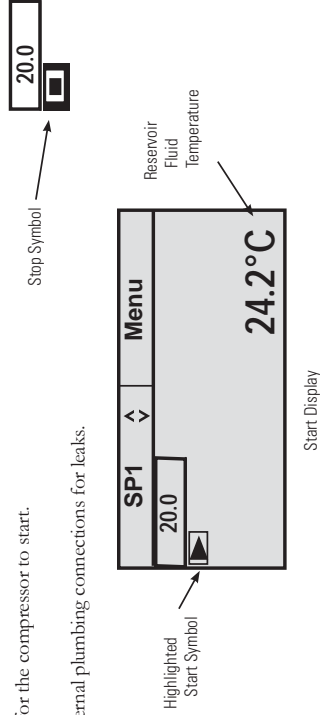

The **SP1** and **Menu** portions on the top of the display are used to view and/or change the controller's settings. They are explained in detail in the manual.

If desired, press  to bring up the Status Displays.

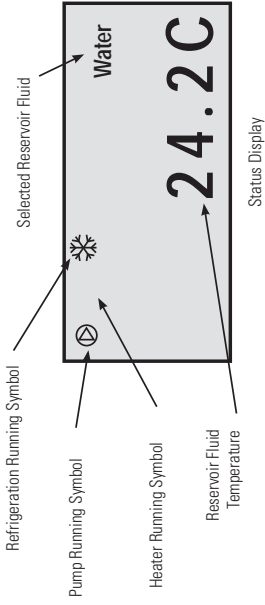

If desired, press  to toggle between the Start/Status Displays.

Shut Down

Ensure the stop symbol has a box around it, if not use the arrow keys to navigate to the symbol.

Press . The chiller will stop and the stop symbol will turn into a start symbol ().

Press . The controller's screen will go blank.

Place the circuit protector on the front of the chiller to the **O** position.

Precauciones de seguridad:

- La unidad está diseñada sólo para uso interior.
- No coloque nunca la unidad donde quede expuesta a exceso de calor, humedad, mala ventilación o materiales corrosivos.
- No utilice nunca fluidos inflamables o corrosivos con esta unidad.
- Nunca conecte líneas de fluidos de proceso al suministro de agua de la instalación ni a ninguna fuente líquida presurizada.
- Antes de utilizar cualquier fluido o realizar operaciones de mantenimiento que entrañen riesgo de contacto con el fluido, consulte las precauciones de manipulación en el documento MSDS del fabricante.

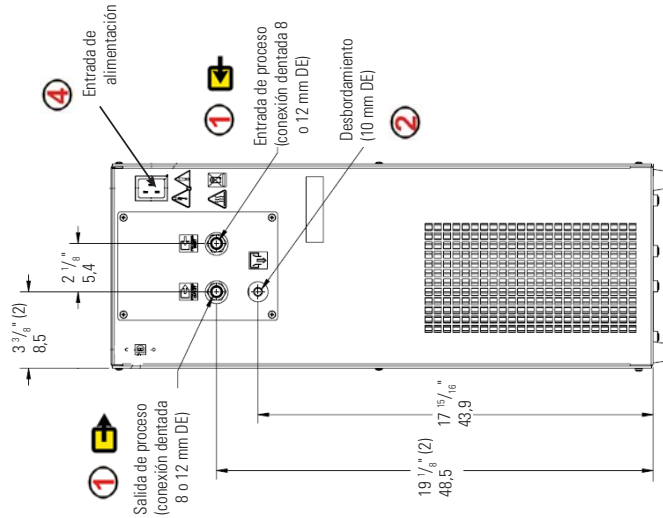

Qué se necesita para empezar:

- Una llave inglesa ajustable
- Manguera o tubería adecuada
- Abrazaderas o tipo de conexión adecuada

1 No olvide quitar todos los tapones de transporte antes de realizar la instalación.

Las conexiones de fluido de proceso se encuentran en la parte posterior de la unidad y llevan las etiquetas (SALIDA DE PROCESO) y (ENTRADA DE PROCESO).

Conecte la SALIDA DE PROCESO a la entrada de fluido de su aplicación. Conecte la ENTRADA DE PROCESO a la salida de fluido de su aplicación. Cerciórese de que todas las conexiones están firmes.

Mantenga la mínima distancia posible entre la unidad y el instrumento que refrigera. Para minimizar la contrapresión, procure que los tubos queden tan rectos como sea posible. Si hace falta reducir diámetros, hágalo en la entrada y la salida de su aplicación, no en el enfriador.

2 Asegúrese de conectar a un desagüe adecuado el orificio de desbordamiento del depósito que hay en la parte posterior de la unidad.

Tabla 1 - Fluidos aceptables:

El uso de cualquier fluido no indicado a continuación anulará la garantía del fabricante.

5°C a 80°C: agua destilada o desionizada (hasta 3 MQ-cm)

-10°C a 80°C: agua con glicol 50/50

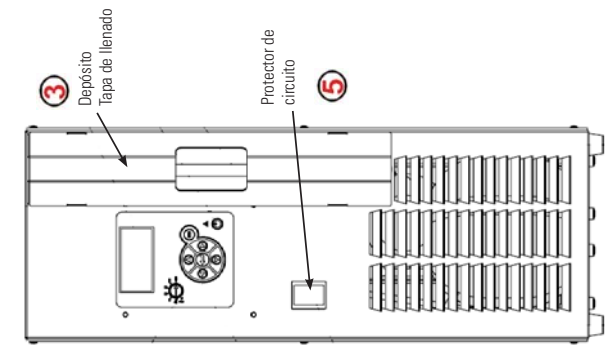

3 Levante el panel frontal de llenado de la unidad para quitarlo. Empiece con 2,8 litros de fluido.

Inserte el embudo suministrado en la manguera y vierta el fluido lentamente. **NOTA:** si introduce el fluido demasiado rápido, la unidad se puede llenar en exceso, porque el indicador del nivel de llenado tarda en reflejar la cantidad añadida debido a la configuración de sus conductos.

Al echar el fluido en el embudo, cerciórese de que toca primero en el como (A). Si el fluido cae directamente en el vástago del embudo (B), se crearán bolsas de aire que ralentizan considerablemente el llenado.

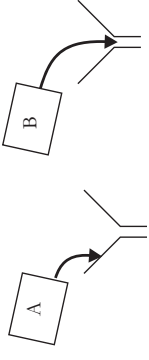

Verifique el nivel de fluido mediante las líneas de llenado.



Como la capacidad del depósito puede ser pequeña para su aplicación y quizá haya que purgar aire de las conducciones, debe tener a mano más fluido refrigerante para mantener lleno el sistema cuando comience la circulación externa.

Evite el llenado excesivo, porque los fluidos se expanden al calentarse.

4 Verifique el voltaje apropiado. En las unidades que incluyen cable de alimentación, conecte el extremo hembra de dicho cable al enfriador y después el extremo macho a la toma de alimentación. (El cable de alimentación se encuentra bajo la tapa del cajón de embalaje. No tire la tapa sin haber localizado el cable.)

5 Coloque el protector de circuito en la posición de encendido (I).

Puesta en marcha

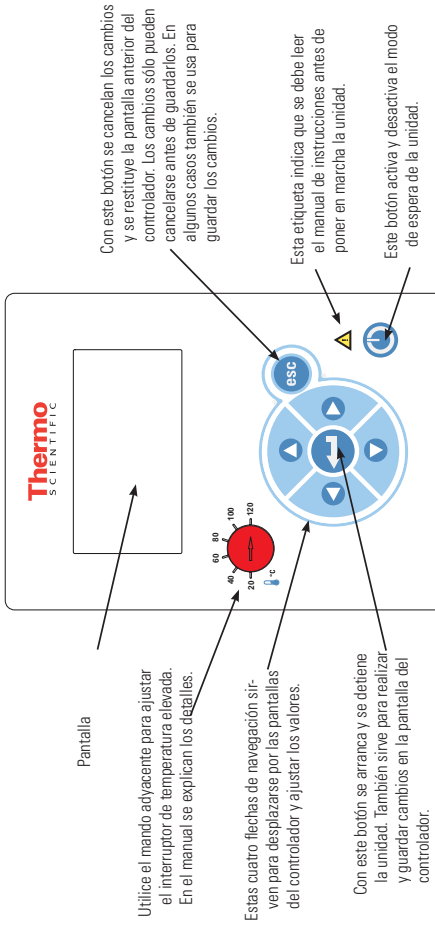

Las unidades deben mantenerse en posición vertical a temperatura ambiente (~25°C) durante 24 horas antes de ponerlas en marcha. Así se asegura que el aceite lubricante ha vuelto al compresor.

Antes de poner en marcha la unidad, verifique todas las conexiones USB (opcional), eléctricas y de conductores.

No ponga en marcha la unidad sin haberle añadido el fluido. Tenga a mano fluido adicional. Si la unidad no arranca, consulte el manual.

- Coloque en la posición **I** el protector de circuito que hay en la parte frontal de la unidad.
- Pulse y aparecerá la pantalla de inicio.
- Compruebe si el símbolo de inicio está rodeado por un cuadro resaltado; de lo contrario, utilice los botones de flecha para ir a dicho símbolo.
- Pulse . La unidad arrancará y el símbolo de inicio cambiará al de parada ().

NOTA: El compresor tarda 30 segundos en arrancar.

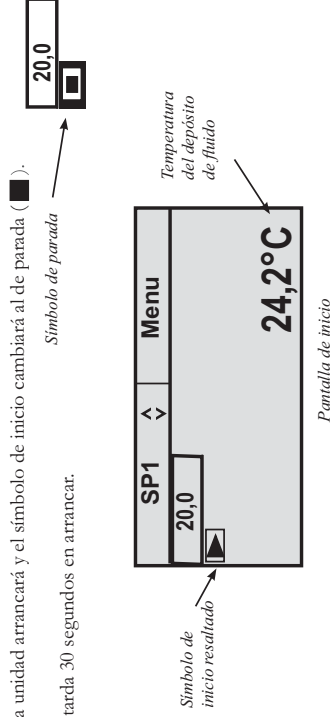

Después de arrancar, busque posibles fugas en todas las conexiones de conductos externas.

Las áreas **SP1** y **Menu** de la parte superior de la pantalla sirven para ver y/o cambiar los ajustes del controlador. Se explican en detalle en el manual.

Para ver las pantallas de estado, pulse .

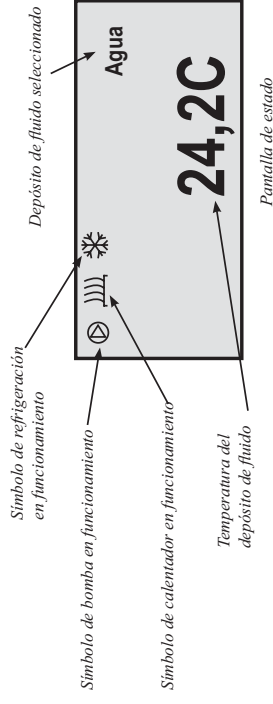

Para cambiar entre las pantallas de inicio/estado, pulse .

Apagado

- Compruebe si el símbolo de parada está rodeado por un cuadro; de lo contrario, utilice los botones de flecha para ir a dicho símbolo.
- Pulse . La unidad se detiene y el símbolo de parada cambia al de inicio ().
- Pulse . La pantalla del termostato queda en blanco.
- Coloque en la posición **O** el protector de circuito que hay en la parte frontal de la unidad.

Sicherheitsvorkehrungen:

Das Gerät darf nur in geschlossenen Räumen betrieben werden. Stellen Sie das Gerät niemals an Orten auf, wo es übermäßiger Hitze, Feuchtigkeit, unzureichender Belüftung oder korrosiven Stoffen ausgesetzt ist. Verwenden Sie niemals brennbare oder korrosive Flüssigkeiten in diesem Gerät.

Schließen Sie niemals Prozessflüssigkeitsleitungen an die Kühlwasserversorgung oder an einen Anschluss für unter Druck stehende Flüssigkeiten an.

Bevor Sie Flüssigkeiten einsetzen oder eine Wartung durchführen, bei denen Sie möglicherweise mit Flüssigkeiten in Berührung kommen, beachten Sie die im Sicherheitsdatenblatt des Herstellers beschriebenen Vorsichtsmaßnahmen.

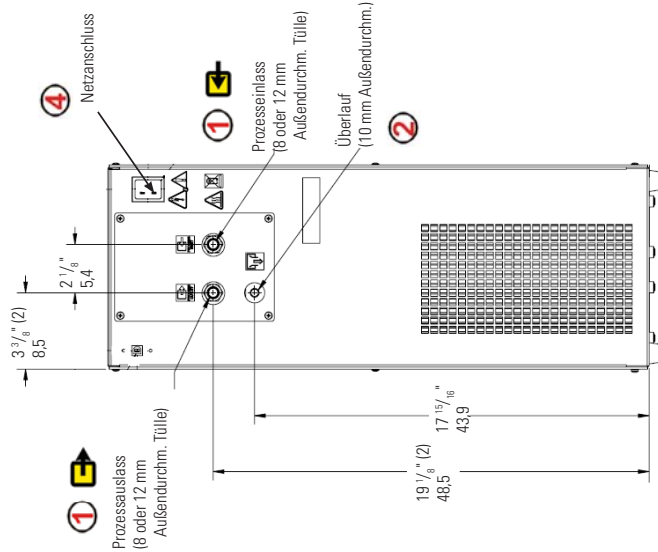

Sie benötigen:

- einen verstellbaren Schraubenschlüssel
- passende Schläuche bzw. Leitungen
- passende Klemmen oder Anschlussstücke

1 Vor der Installation müssen alle Transportstopfen entfernt worden sein.

Die Anschlüsse für die Prozessflüssigkeit befinden sich auf der Geräterückseite und sind mit den Symbolen (PROZESSFLÜSSIGKEITSAUSLASS) und (PROZESSFLÜSSIGKEITSEINLASS) gekennzeichnet.

Verbinden Sie den PROZESSFLÜSSIGKEITSAUSLASS mit dem Flüssigkeitseinlass Ihrer Applikation. Verbinden Sie mit dem Flüssigkeitseinlass Ihrer Applikation. Alle Verbindungen müssen fest und sicher sitzen.

Halten Sie den Abstand zwischen dem Gerät und dem zu kühlenden Instrument so klein wie möglich. Zur Minimierung des Rückstaudruckes müssen die Schläuche möglichst gerade verlaufen. Wenn kleinere Durchmesser erforderlich sind, sollten diese am Ein- und Auslass Ihrer Applikation und nicht am Kühlaggregat angeschlossen werden.

2 Der auf der Rückseite des Gerätes befindliche Behälterüberlaufstutzen muss an einen geeigneten Abfluss angeschlossen sein.

Tabelle 1 - Zulässige Flüssigkeiten:

Die Verwendung anderer Flüssigkeiten als der nachstehend aufgeführten führt zum Verlust der Herstellergarantie.
5°C bis 80°C — destilliertes oder deionisiertes Wasser (bis zu 3 MΩ·cm)
-10°C bis 80°C — Wasser mit Glykol im Mischungsverhältnis 50:50

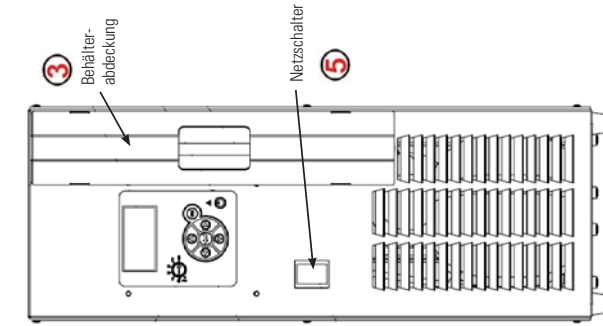

3 Behälterabdeckung an der Gerätevorderseite hochheben, um sie zu entfernen.

Füllen Sie zunächst 2,8 l Flüssigkeit ein.

Stecken Sie den mitgelieferten Trichter in den Schlauch und befüllen Sie den Behälter *langsam*. **HINWEIS** Wegen der Konstruktion des Gerätebehälters kann ein zu schnelles Befüllen zu Überfüllungen führen - die Füllstandsanzeige besitzt eine gewisse Verzögerung, sodass die tatsächlich eingefüllte Menge etwas über der Füllstandsanzeige liegt.

Achten Sie beim Befüllen des Behälters darauf, dass die Flüssigkeit an der Trichterseite in den Behälter läuft, A. Durch Gießen der Flüssigkeit direkt in die Trichtermitte (B) bilden sich Luftblasen, die die Füllzeit erheblich verlängern.

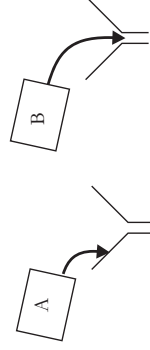

Überprüfen Sie den gewünschten Flüssigkeitsstand an den Füllmarkierungen.



Da möglicherweise die Kapazität des Behälters im Vergleich zu Ihrer Applikation eher gering ist und Luft aus den Leitungen gespült werden muss, sollten Sie weitere Kühlflüssigkeit zum Nachfüllen bereithalten, wenn der externe Kreislauf gestartet wird.

Vermeiden Sie Überfüllungen - Flüssigkeiten dehnen sich bei Erwärmung aus.

4 Kontrollieren Sie, dass die korrekte Spannung eingestellt ist. Stecken Sie bei Geräten mit Stromkabel zunächst das geräteseitige Ende in das Kühlgerät und anschließend den Stecker in eine Steckdose. (Das Stromkabel befindet sich unter dem Deckel der Transportkiste. Werfen Sie den Transportverpackung erst weg, wenn Sie das Stromkabel herausgeholt haben.)

5 Schalten Sie den Netzschalter in die Stellung (I).

Einschalten

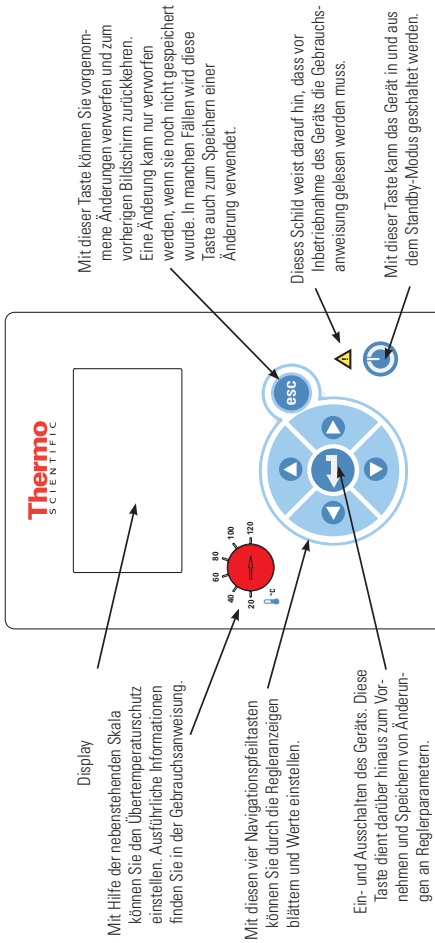

Vor dem Einschalten muss das Gerät mindestens 24 Stunden lang bei ~25°C in aufrechter Position gestanden haben. Dadurch wird gewährleistet, dass das Schmieröl zurück in den Kompressor fließt.

Inspezieren Sie vor dem Einschalten alle elektrischen Anschlüsse, Schlauchverbindungen und (optional) USB-Kabelanschlüsse.

Das Gerät niemals mit leerem Behälter betreiben. Halten Sie zusätzliche Flüssigkeit griffbereit. Konsultieren Sie die Gebrauchsanweisung, wenn sich das Gerät nicht einschaltet.



- Schalten Sie den Netzschalter auf der Gerätevorderseite in die Stellung **I**.

- Drücken Sie auf . Die Startanzeige erscheint.

- Das Startsymbol muss hervorgehoben sein. Gehen Sie mit den Pfeiltasten zu diesem Symbol, wenn dies nicht der Fall ist.

- Drücken Sie . Das Gerät wird gestartet, und statt dem Startsymbol wird jetzt das Stoppsymbol () angezeigt.

HINWEIS Es dauert 30 Sekunden, bis der Kompressor anläuft.

Überprüfen Sie nach dem Start alle externen Schlauchanschlüsse auf Dichtheit.

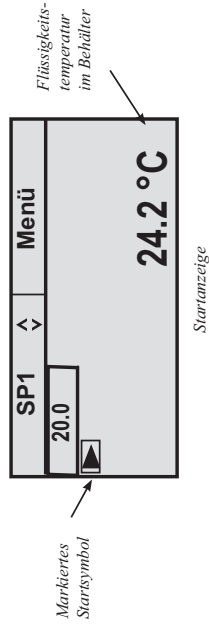

Über die Optionen **SP1** und **Menü** am oberen Bildschirmrand können die Reglereinstellungen angezeigt und/oder geändert werden. Sie werden ausführlich in der Gebrauchsanweisung erläutert.

Drücken Sie bei Bedarf auf , um die Statusanzeigen einzublenden.

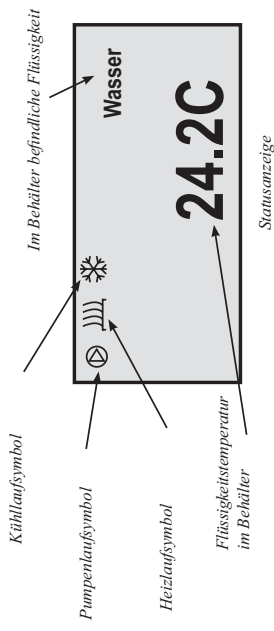

Drücken Sie bei Bedarf auf , um zwischen der Startanzeige und den Statusanzeigen umzuschalten.

Ausschalten

Achten Sie darauf, dass das Stopp-Symbol in einem Kästchen erscheint. Navigieren Sie mit den Pfeiltasten auf das Symbol, wenn dies nicht der Fall ist.

Drücken Sie . Das Gerät wird gestoppt, und statt dem Stoppsymbol wird jetzt das Startsymbol () angezeigt.

Drücken Sie . Das Thermostat-Display erlischt.

Schalten Sie den Netzschalter auf der Gerätevorderseite in die Stellung **O**.

Consignes de sécurité :

- Cet appareil est exclusivement destiné à une utilisation intérieure.
- Ne jamais l'exposer à une chaleur ou une humidité excessive, à une ventilation inadéquate ou à des matières corrosives.
- Ne jamais utiliser de liquides inflammables ou corrosifs avec cet appareil.
- Ne jamais raccorder les conduites de liquide de process à l'arrivée d'eau de votre site ou à une source de liquide sous pression.
- Avant d'utiliser un quelconque liquide ou d'effectuer des travaux d'entretien susceptibles d'entraîner un contact avec le liquide, consulter la fiche technique santé-sécurité du fabricant.

Matériel requis pour démarrer :

- clé à molette
- flexible et matériel de plomberie approprié
- colliers de serrage ou raccord adaptateur de taille appropriée

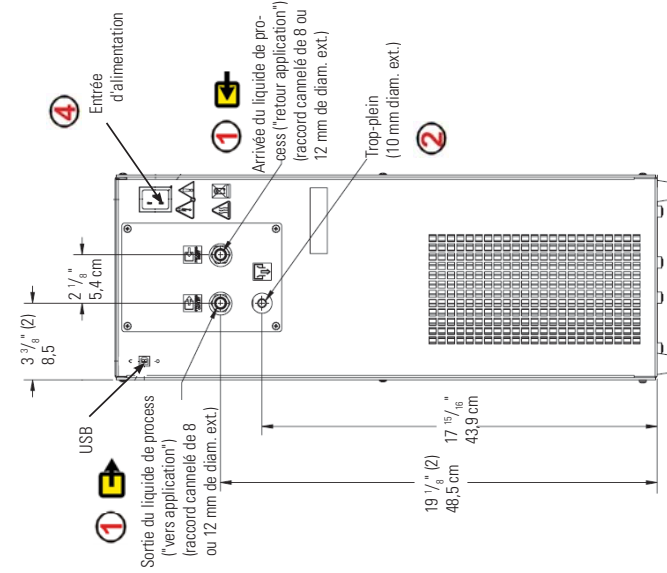

- 1 Veiller à enlever tous les bouchons d'expédition avant l'installation.
Les raccords fluidiques se situent à l'arrière de l'appareil et sont étiquetés **(SORTIE DE LIQUIDE "VERS APPLICATION")** et **(ARRIVÉE DE LIQUIDE "RETOUR APPLICATION")**.
Raccorder la **SORTIE DE LIQUIDE DE PROCESS "VERS APPLICATION"** à l'arrivée de liquide de l'application. Raccorder l'**ARRIVÉE DE LIQUIDE DE PROCESS "RETOUR APPLICATION"** à la sortie de liquide de l'application. S'assurer que tous les raccords sont bien serrés.

Maintenir la plus courte distance possible entre l'appareil et l'instrument refroidi. Pour minimiser la contre-pression, s'assurer que la tubulure est la plus droite possible. Si des réductions de diamètre s'imposent, les réaliser à l'arrivée et à la sortie de l'application, et pas du côté refroidisseur.

- 2 S'assurer que le trop-plein du réservoir situé à l'arrière de l'appareil est raccordé à une conduite de vidange adaptée.

Tableau 1 – Liquides autorisés :

L'utilisation d'un quelconque liquide ne figurant pas dans la liste ci-dessous annule la garantie du fabricant.
5 à 80 °C — eau distillée ou désionisée (3 MQ-cm max.)
-10 à 80 °C — mélange eau/glycol 50/50

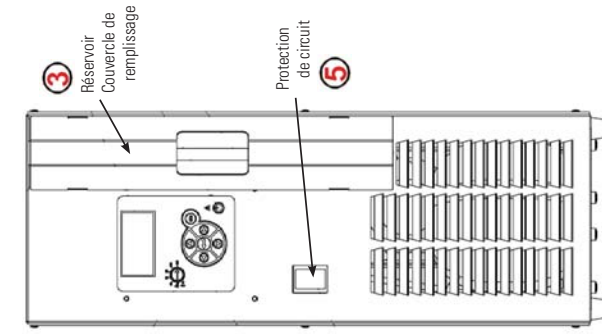

- 3 Soulever le panneau de remplissage sur l'avant de l'appareil pour l'enlever.
Démarrer avec 2,8 litres de liquide.

Insérer l'entonnoir fourni dans le flexible et ajouter *progressivement* du liquide. **REMARQUE** Etant donné la configuration de la plomberie de l'appareil, l'ajout trop rapide de liquide risque de causer un remplissage excessif - l'indication de niveau au repère de remplissage a un léger retard par rapport au volume ajouté.

Le versement de liquide dans l'entonnoir garantit que le liquide est tout d'abord en contact avec la paroi de l'entonnoir (A). Le versement de liquide au centre de l'entonnoir (B) cause des poches d'air et ralentit sensiblement le temps de remplissage.

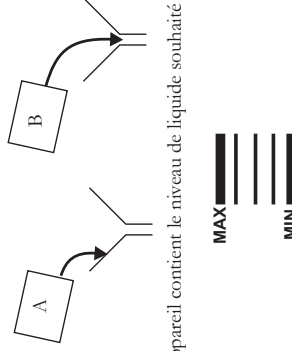

Vérifier si l'appareil contient le niveau de liquide souhaité d'après les repères.

La capacité du réservoir pouvant être réduite par rapport à l'application et de l'air pouvant être purgé des conduites, garder du liquide d'appoint à portée de la main pour faire le niveau du système une fois la circulation externe démarrée.

Éviter de trop remplir les récipients - les liquides se dilatent quand ils chauffent.

- 4 Vérifier si la tension est correcte. Pour les appareils fournis avec un cordon d'alimentation, insérer la prise femelle de ce dernier dans le refroidisseur et la prise mâle dans la prise secteur. (Le cordon d'alimentation se trouve sous le couvercle de la caisse d'expédition. Ne pas jeter le couvercle avant d'avoir localisé le cordon.)

- 5 Placer la protection de circuit en position (I).

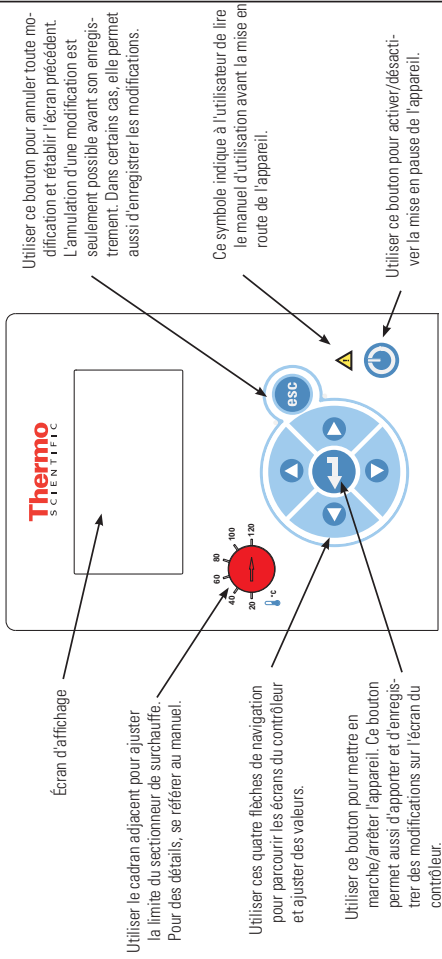

Mise en route



Les appareils doivent rester à la verticale à température ambiante (~25 °C) pendant 24 heures avant leur mise en marche. Ainsi, l'huile lubrifiante sera renvoyée au compresseur.

Avant de démarrer l'appareil, vérifier tous les connecteurs USB, électriques, et les raccords de plomberie.

Ne pas mettre l'appareil en marche sans liquide à l'intérieur. Avoir du liquide d'appoint sous la main. Si l'appareil ne démarre pas, se reporter au manuel.

- Placer la protection de circuit située à l'avant de l'appareil en position I.
- Appuyer sur  : l'écran de démarrage s'affiche.
- S'assurer que le symbole Marche est encadré d'une surbrillance ; sinon, utiliser les touches fléchées pour naviguer jusqu'au symbole.
- Appuyer sur  : L'appareil démarre et le symbole Marche est remplacé par le symbole Arrêt ().

REMARQUE Le démarrage du compresseur prend 30 secondes environ.

Après démarrage, vérifier l'étanchéité de tous les raccords de plomberie externes.

Les sections **SP1** et **Menu** en haut de l'écran permettent d'afficher et/ou de modifier les paramètres du contrôleur.

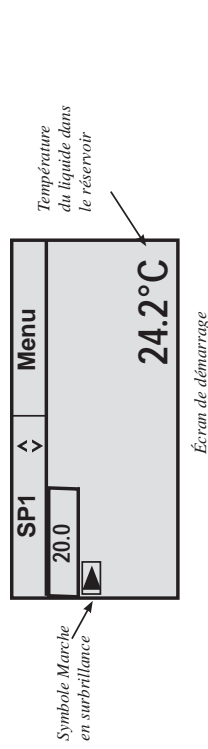

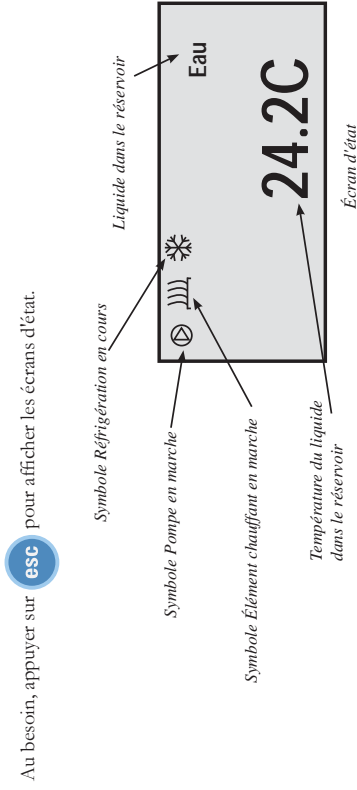

Pour des détails, se référer au manuel.



Au besoin, appuyer sur  pour basculer entre l'écran de démarrage et l'écran d'état.

Arrêt

S'assurer que le symbole Arrêt est encadré d'une surbrillance ; sinon, utiliser les touches fléchées pour naviguer jusqu'au symbole.

- Appuyer sur  : L'appareil démarre et le symbole Arrêt est remplacé par le symbole Marche ().
 - Appuyer sur  : L'écran du thermostat s'éteint.
- Placer la protection de circuit située à l'avant de l'appareil en position O.

Veiligheidsmaatregelen:

- De unit is alleen ontworpen voor gebruik binnenshuis.
- Plaats een unit nooit op een plek met overmatige warmte, vocht, onvoldoende ventilatie of corrosieve materialen.
- Gebruik nooit ontvlambare of corrosieve vloeistoffen met deze unit.
- Sluit nooit proces vloeistofleidingen aan op de gebouw water voorziening of andere vloeistofbronnen onder druk.
- Raadpleeg voordat u vloeistoffen gebruikt of onderhoud uitvoert op plekken waar mogelijk contact is met vloeistof, de veiligheidsbladen van de fabrikant voor voorzorgsmaatregelen.

Dit heeft u nodig om te kunnen beginnen:

- Een verstelbare steekselnetel
- Een geschikte slang of leiding
- Klemmen van de juiste grootte of type aansluiting

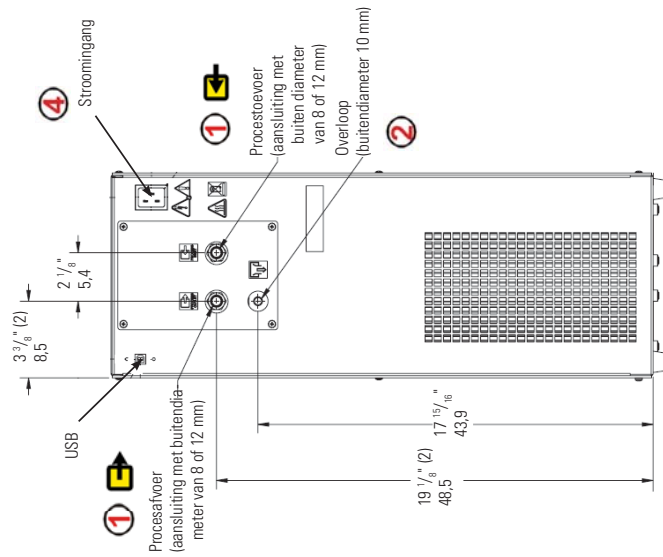

1 Zorg ervoor dat alle verzendpluggen verwijderd worden voor de installatie.

De aansluitingen voor de procesvloeistof bevinden zich op de achterzijde van de unit en zijn als volgt gelabeld: **PROCESSAFVOER** en **PROCESTOEVOER**.

Sluit de **PROCESAFVOER** aan op de vloeistofvoeder op uw toepassing. Sluit de **PROCESTOEVOER** aan op de vloeistofafvoer op uw toepassing. Zorg ervoor dat alle aansluitingen veilig zijn.

Houd de afstand tussen de unit en het instrument dat gekoeld wordt zo kort mogelijk. Zorg dat de leidingen zo recht mogelijk zijn om tegendruk zo klein mogelijk te houden. Als verkleiningen van de diameter vereist zijn, maak deze dan bij de toevoer en de afvoer van uw toepassing, niet bij de koeler.

2 Zorg ervoor dat de reservoir-overloop op de achterkant van de unit wordt aangesloten op een geschikte afvoer.

Tabel 1 – Toegestane vloeistoffen:

Door gebruik van vloeistoffen die niet hieronder worden vermeld komt de fabrieksgarantie te vervallen.
5°C tot 80°C — Gedestilleerd of gedetonneerd water (tot maximaal 3 MΩ·cm)
-10°C tot 80°C — 50/50 water met glycol

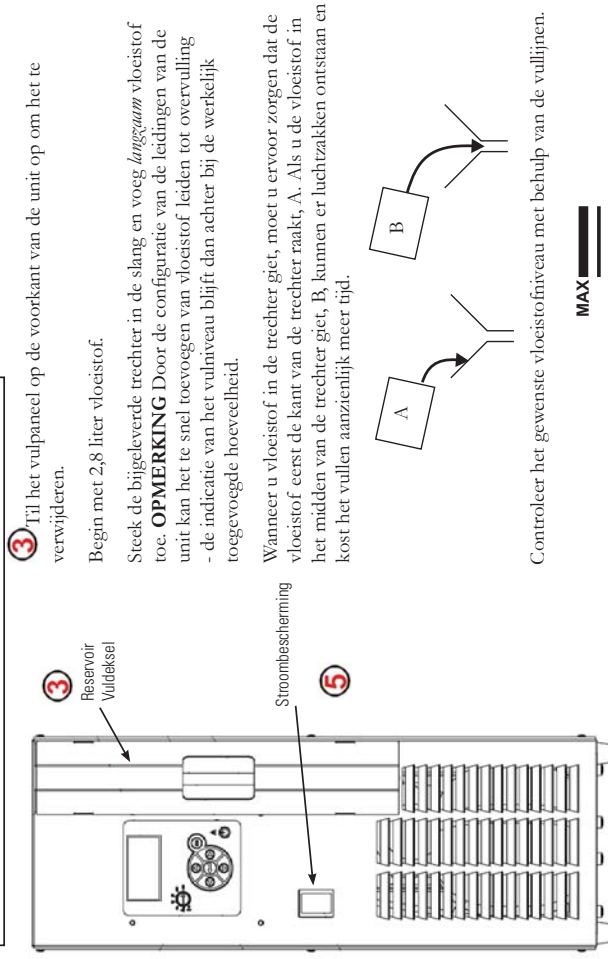

3 Til het vulpaneel op de voorkant van de unit op om het te verwijderen.
Begin met 2,8 liter vloeistof.

Steek de bijgeleverde trechter in de slang en voeg *langzaam* vloeistof toe. **OPMERKING** Door de configuratie van de leidingen van de unit kan het te snel toevoegen van vloeistof leiden tot overvulling - de indicatie van het vulniveau blijft dan achter bij de werkelijk toegevoegde hoeveelheid.

Wanneer u vloeistof in de trechter giet, moet u ervoor zorgen dat de vloeistof eerst de kant van de trechter raakt, A. Als u de vloeistof in het midden van de trechter giet, B, kunnen er luchtzakken ontstaan en kost het vullen aanzienlijk meer tijd.

Controleer het gewenste vloeistofniveau met behulp van de vullijnen.



Aangezien de capaciteit van het reservoir klein kan zijn in vergelijking tot uw toepassing en het nodig kan zijn dat er lucht uit de leidingen geblazen moet worden, dient u extra koelvloeistof bij de hand te houden om het systeem bijgevuld te houden als de uitwendige circulatie wordt gestart.

Vul het reservoir niet te vol; vloeistoffen zetten uit bij verwarming.

4 Controleer de juiste spanning. Voor units die worden geleverd met een netsnoer, steek de vrouwelijke kant van de stroomkabel in de koeler en steek de mannelijke kant van de stroomkabel in de vermogensuitgang. (Het netsnoer bevindt zich onder de deksel van de transportdoos. Gooi het deksel niet weg voordat u het snoer heeft gevonden.)

5 Zet de stroombeschermer op de aan (I)-stand.

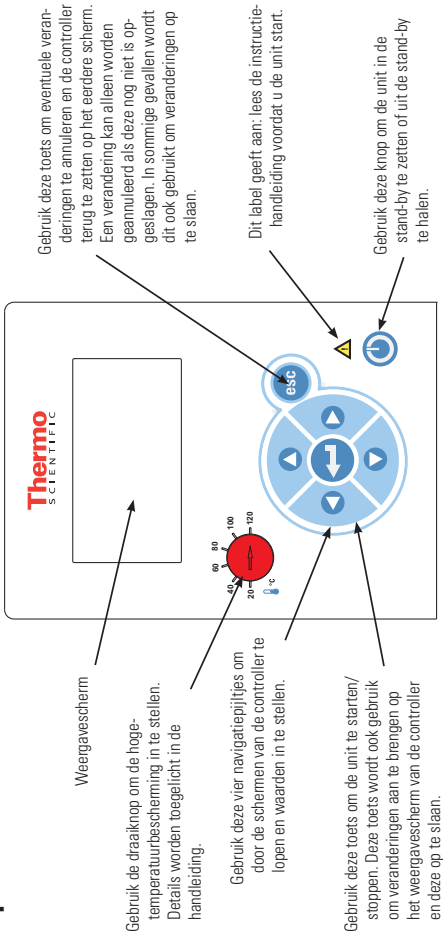

Opstarten



Units moeten gedurende 24 uur voordat ze gestart worden rechtop staan bij kamertemperatuur (~25°C). Hierdoor wordt gegarandeerd dat de smeerolie teruggelopen is in de compressor.

Controleer voordat u de unit start alle USB en elektrische aansluitingen en de aansluitingen van de vloeistofleidingen.

Schakel de unit niet in voordat u vloeistof heeft toegevoegd. Houd extra vloeistof bij de hand. Als de unit niet start, raadpleeg dan de handleiding.

- Zet de stroombeschermer op de voorkant van de unit in de **I**-stand.
- Druk op , het Startscherm verschijnt.
- Controleer of het startsymbool gemarkeerd is; als dit niet het geval is, gebruik dan de pijltoetsen om naar het symbool te navigeren.
- Druk op . De unit start en het startsymbool verandert in een stopsymbool ().

OPMERKING

Het duurt 30 seconden voordat de compressor start.



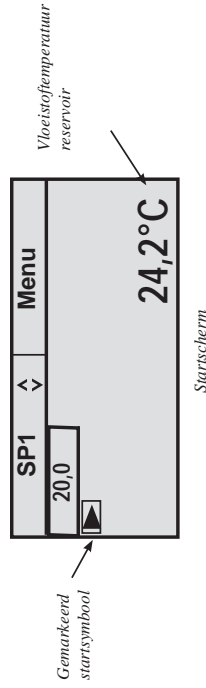

Controleer na het starten alle externe leidingen op lekken.

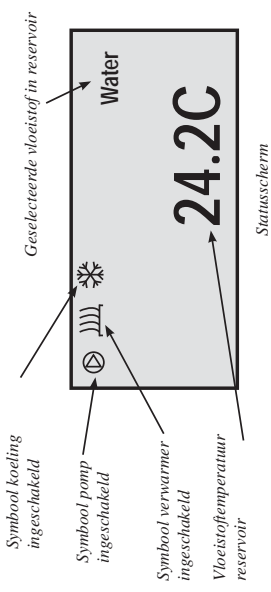

De gedeeltes **SP1** en **Menu** bovenaan het scherm worden gebruikt om de instellingen van de controller af te lezen bekijken en/of te wijzigen. Deze worden uitgebreid beschreven in de handleiding.

Druk indien gewenst op  om de statusschermen te openen.



Druk indien gewenst op  om heen en weer te gaan tussen de start-/ statusschermen.

Uitschakelen

Controleer of het stopsymbool gemarkeerd is; als dit niet het geval is, gebruik dan de pijltoetsen om naar het symbool te navigeren.

Druk op . De unit stopt en het stopsymbool verandert in een startsymbool ().

Druk op . Het thermostaatscherm wordt blanco.

Zet de stroombeschermer op de voorkant van de unit in de **O**-stand.

Preface

Compliance

Refer to the Declaration of Conformity in the back of this manual.

After-sale Support

Thermo Fisher Scientific is committed to customer service both during and after the sale. If you have questions concerning the chiller operation, or questions concerning spare parts or Service Contracts, call our Sales, Service and Customer Support. Phone number are on the inside cover.

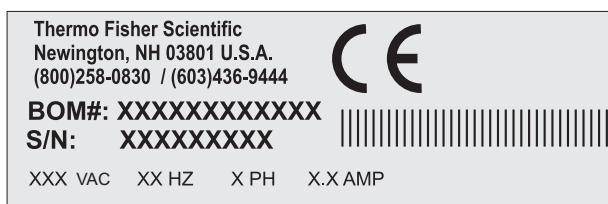

Sample Nameplate

Before calling, please obtain the serial number printed on the nameplate located on the upper rear of the chiller.

Feedback

We appreciate any feedback you can give us on this manual. Please e-mail us at tcmanuals@thermofisher.com. Be sure to include the manual part number and the revision date on the front cover.

Warranty

Thermo Scientific Cooling/Heating Recirculating Chillers have a warranty against defective parts and workmanship for 24 months from date of shipment. See back page of this manual for more details.

Unpacking

Retain all cartons and packing material until the chiller is operated and found to be in good condition. If the chiller shows external or internal damage contact the transportation company and file a damage claim. Under ICC regulations, this is your responsibility.



The chiller does not have handles. Take into account its weight, 66 pounds (30 kilograms), when unpacking and transporting. We recommend two people lift the chiller from the bottom. ▲

Note Leave chillers in an upright position at room temperature (~25°C) for 24 hours before starting. This ensures the lubrication oil has drained back into the compressor. ▲

Section 1 Safety

Safety Warnings

Make sure you read and understand all instructions and safety precautions listed in this manual before installing or operating your chiller. If you have any questions concerning the operation of your chiller or the information in this manual, please contact us.



DANGER indicates an imminently hazardous situation which, if not avoided, *will* result in death or serious injury.



WARNING indicates a potentially hazardous situation which, if not avoided, *could* result in death or serious injury.



CAUTION indicates a potentially hazardous situation which, if not avoided, may result in minor or moderate injury. It is also be used to alert against unsafe practices.



The lightning flash with arrow symbol, within an equilateral triangle, is intended to alert the user to the presence of non-insulated "dangerous voltage" within the chiller's enclosure. The voltage magnitude is significant enough to constitute a risk of electrical shock.



This label indicates the presence of hot surfaces.



This label indicates read the manual.

Note The chiller's equipment design incorporates a complete sheet metal enclosure for personnel protection from mechanical and electrical hazards. ▲

Observe all warning labels. ▲

Never remove warning labels. ▲

The chiller's construction provides protection against the risk of electrical shock by grounding appropriate metal parts. The protection will not function unless the power cord is connected to a properly grounded outlet. It is the user's responsibility to assure a proper ground connection is provided. ▲

Operate the chiller using only the supplied line cords, never operate equipment with damaged cords. ▲

Ensure all communication and electrical connections are made prior to starting the chiller. ▲

The chiller's power cord is the electrical disconnecting device, it must be easily accessible at all times. ▲

Always turn the chiller off and disconnect the supply voltage from its power source before moving performing any service or maintenance procedures. Ensure chiller is at a safe temperature ($\sim 40^{\circ}\text{C}$) before handling or draining. ▲

Never place the chiller in a location or atmosphere where excessive heat, moisture, or corrosive materials are present. ▲

Leave chillers in an upright position at room temperature ($\sim 25^{\circ}\text{C}$) for 24 hours before starting. This ensures the lubrication oil has drained back into the compressor. ▲

The chiller is not designed to be floor mounted. ▲

Other than water, before using any fluid, or when performing maintenance where contact with the fluid is likely, refer to the manufacturer's MSDS and EC Safety Data sheet for handling precautions. ▲

Ensure, that no toxic gases can be generated by the fluid. Flammable gases can build up over the fluid during usage. ▲

Never operate the chiller without fluid in the reservoir. ▲

Only use approved fluids with this chiller. Use of any other fluids voids the manufacturer's warranty. ▲

The user is responsible for decontamination if hazardous materials are spilled. Consult the manufacturer regarding decontamination and or cleaning agents compatibility. ▲

Drain the chiller before it is transported and/or stored in near or below freezing temperatures, see Draining in Section 3. ▲

Ensure the tubing you select meets your maximum temperature and pressure requirements. ▲

Never operate damaged or leaking equipment. ▲

Never operate the chiller or add fluid to the reservoir with panels removed. ▲

Transport the chiller with care. Sudden jolts or drops can damage its components. ▲

Do not clean the chiller with solvents, only use a soft cloth and water. ▲

Refer service and repairs to a qualified technician. ▲

Performance of installation, operation, or maintenance procedures other than those described in this manual may result in a hazardous situation and voids the manufacturer's warranty. ▲

Element Assessment

Chemical Used —

R134A Refrigerant - CFC Free

Amount: 178 grams (6.7 ounces)

Location: Refrigeration system

Lubricating Oil: Polyol Ester

Amount: 243 milliliters (8.2 ounces)

Location: Compressor

Hazard Communication — None

Electrical — All electrical energy sources for the chiller are provided by the user.

Hazardous Energy Isolation — Locate energy isolation devices in a location that is readily accessible.

Electrical Remove power from the chiller by turning the circuit protector off and disconnecting the line cord, see Section 3 **Electrical Requirements**.

Fluid Before using any fluid refer to the manufacturer's MSDS and EC safety data sheets for handling precautions. The user is responsible to ensure the reservoir overflow located on the rear of the chiller is connected to a suitable drain.

Refrigeration The chiller's refrigeration system is sealed and requires no lockout/tagout.

Remove any isolation devices before starting the chiller.

Chemicals — Prior to decontamination, develop and employee procedures to minimize or mitigate opportunities for exposure to chemicals present in or around the chiller.

Radioactive Material — None

Magnetic Fields — None

Sampling and Analysis for External Contaminants from Other Sources or from Spill Events

It is the responsibility of the user to identify the presence of all external chemicals before the decontamination. Accomplish this by collecting samples and analyzing them for any suspected chemicals used or stored in areas adjacent to the chiller.

Oxygen Deficiency — Many refrigerants which may be undetectable by human senses are heavier than air and will replace the oxygen in an enclosed area causing loss of consciousness. Refer to the chiller's nameplate and the manufacturer's most current MSDS for additional information. Test the atmosphere in a confined space area or area where gases are being used to purge the chiller. If necessary, use an air supplied respirator.

Personal Protective Equipment

The are no special personal protective equipment requirements needed to perform normal operation. We do recommend wearing protective clothing and using eye protection.

Training

The user must review and understand all the sections in this manual before operating the chiller.

Section 2 General Information

Description and Intended Use

The Thermo Scientific Accel Series of Cooling/Heating Recirculating Chillers are designed to provide a continuous supply of fluid at a constant temperature and flow rate to an external system. The chiller consists of an air-cooled refrigeration system, heat exchanger, recirculating pump, polyethylene reservoir, and a microprocessor controller.

All chillers have a low liquid level protection device.

Chillers are designed for continuous operation and for indoor use on a work bench or table top only, not floor standing. Use the chiller in accordance with all the procedures and requirements stated in this manual.

Specifications

Process Fluid Temperature Range

Temperature Stability

Cooling Capacity¹

	Accel 250 LC/Accel 500 LC	Accel 500 LT	Accel 500 LT/HT
Process Fluid Temperature Range	-10°C to +80°C +14°F to +176°F	-25°C to +80°C -13°F to +176°F	-25°C to +95°C -13°F to +203°F
Temperature Stability	±0.1°C	±0.1°C	±0.1°C
Cooling Capacity ¹			
Heater Capacity at 20°C 50Hz/60Hz	2.0 / 1.2 Kilowatts	2.0 / 1.2 Kilowatts	2.0 / 1.2 Kilowatts
Nominal Weight kg/lb	30 / 66	30 / 66	30 / 66
Pumping Type ² (see next page for curves)	Force / Force-Suction	Force / Force-Suction	Force / Force-Suction
Maximum Flow Rate lpm gpm	15 / 21 4.0 / 5.5	15 / 21 4.0 / 5.5	15 / 21 4.0 / 5.5
Maximum Pressure mbar psi	300 / 805 4.4 / 11.7	300 / 805 4.4 / 11.7	300 / 805 4.4 / 11.7
Reservoir Volume liters/gallons	2.8 / 0.7	2.8 / 0.7	2.8 / 0.7
Serial Interface	USB	USB	USB

1. Specifications obtained at sea level using water (above 5°C) and 50/50 EG/Water (<5°C) as the recirculating fluid at a 20°C process setpoint, 20°C ambient condition, at nominal operating voltage. Other fluids, process temperatures, ambient temperatures, altitude or operating voltage will affect performance.

2. Nominal values ±10%. Depends on chiller's pump type, force only or force/suction. Derate 100V/50Hz chillers ~15% for maximum pressure and maximum flow.

• Thermo Fisher Scientific reserves the right to change specifications without notice.

FP1 Pumping Capacity

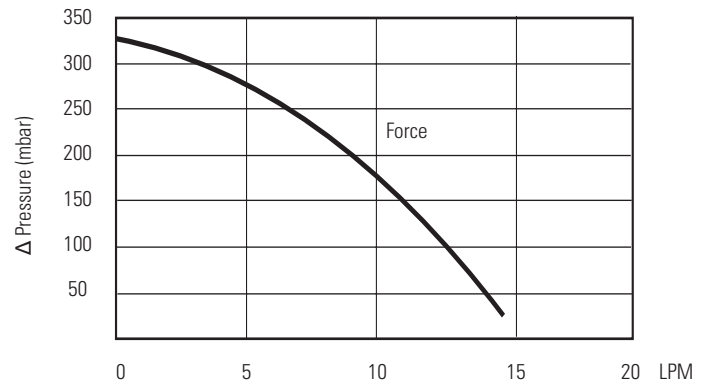

FP2 Pumping Capacity

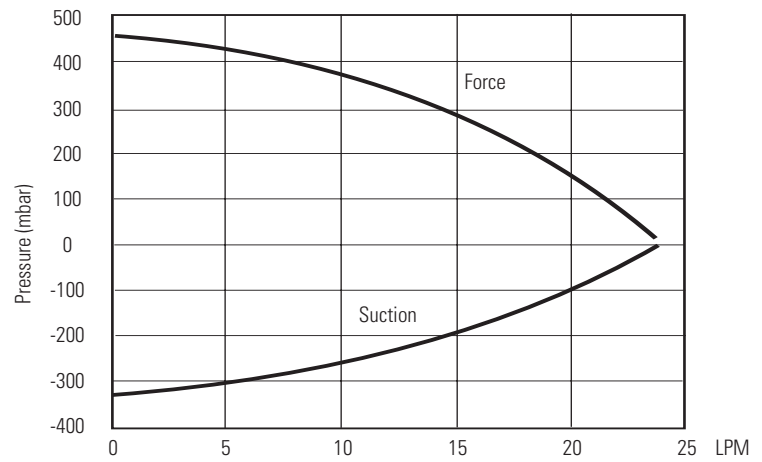

Time to Temperature

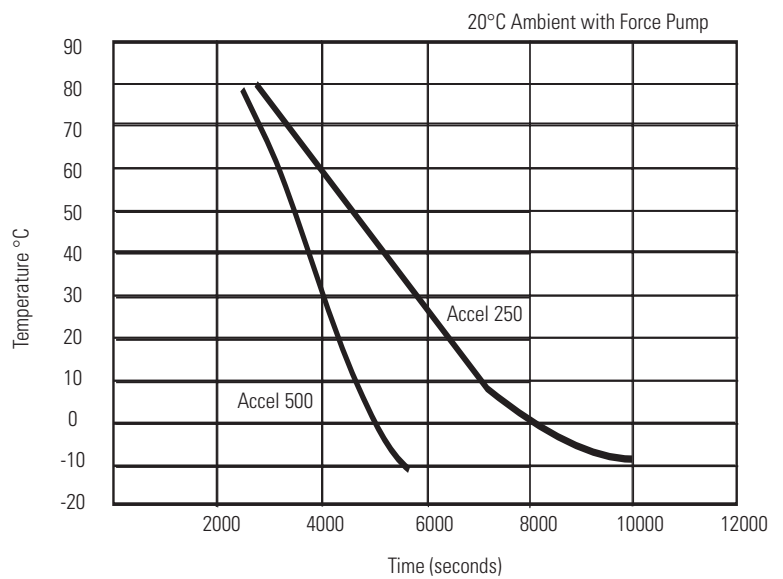

Dimensions
(inches/centimeters)
Top View

H x W x D
24.8 x 9.1 x 19.2 in
(62.0 x 23.2 x 48.7 cm)

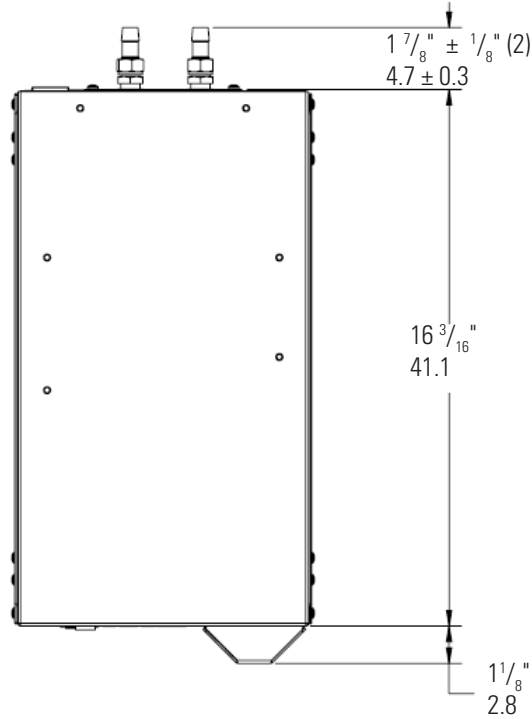

Front View

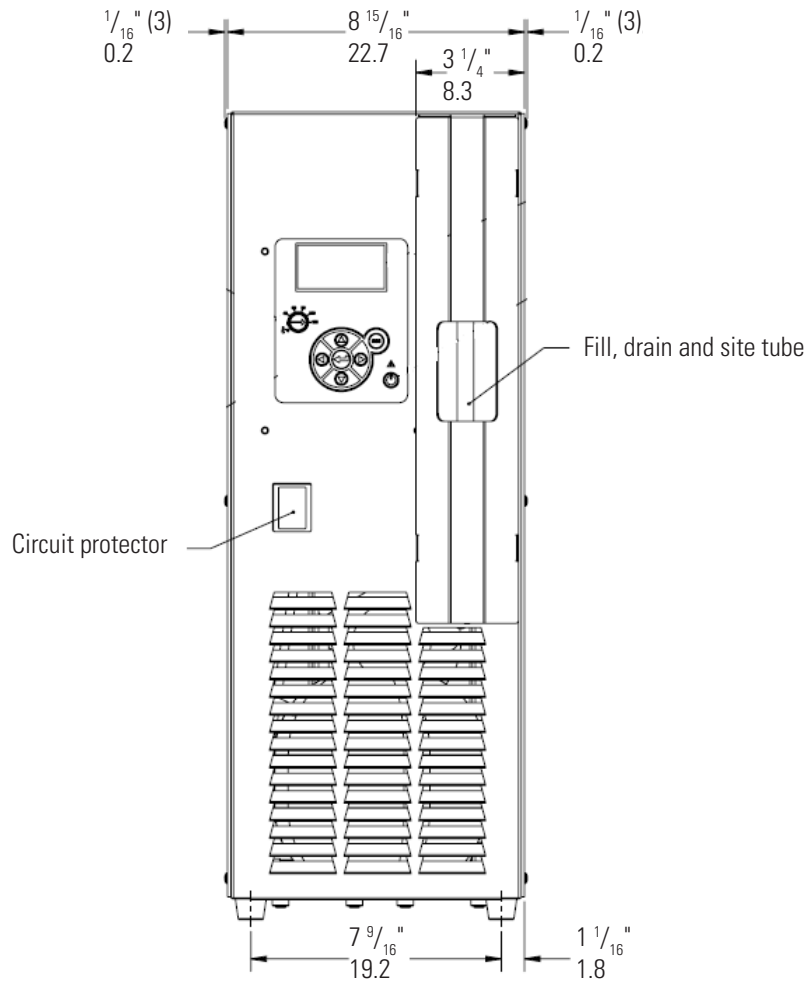

Rear View

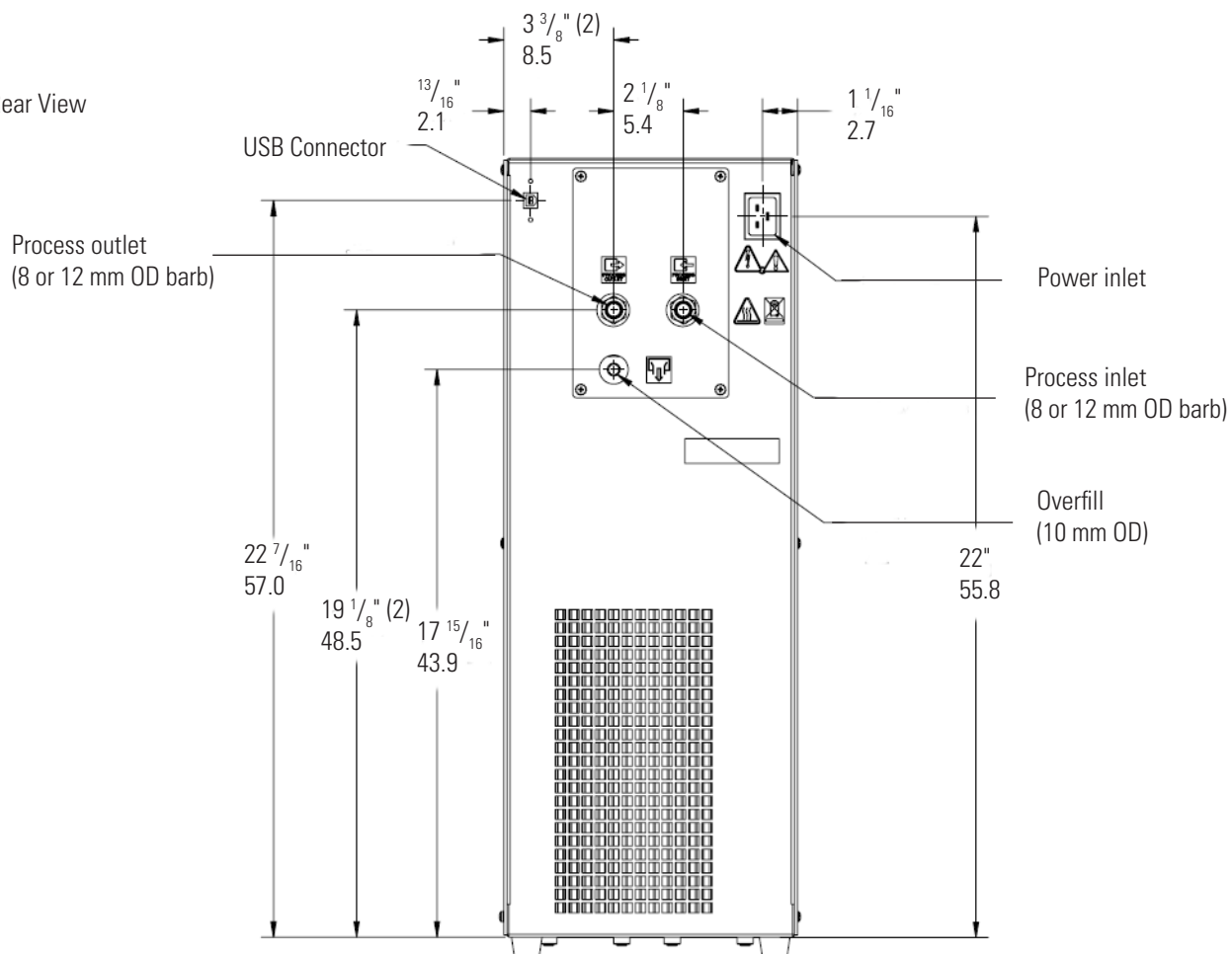

Side View

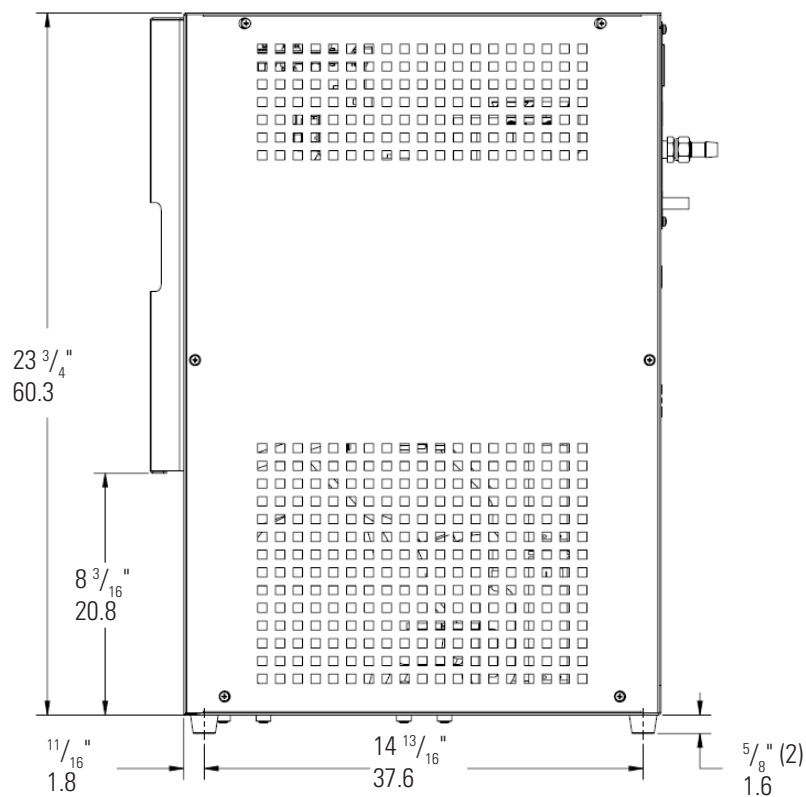

Equipment Ratings

Compliance



Ambient Temperature Range 10°C to 40°C (50°F to 104°F)

Maximum Relative Humidity (Non Condensing)* 0% to 80% at 31°C (88°F)

Operating Altitude* Sea Level to 2000 meters (6560 feet)

Overvoltage Category II

Pollution Degree 2

Degree of Protection IP 20

Sound Power Level less than 58 dBA

Refrigerant 6.7 ounces R134A

*Limited by ambient temperature, elevation & operating temperature. Maximum relative humidity 80% for temperatures up to 31°C decreasing linearly to 50% relative humidity at 35°C Elevation above sea level requires reduction of 1°C/1000m on maximum ambient and 2%/1000m reduction in rated capacity.

The following power options are available:

Volts/Hertz/Phase	Amps ²	Total Wattage	Plug Type
115/60/1	12	1345	N5-15
100/50-60/1	12	1150	N5-15
220- 230/50/1	12	2395	Country Specific
220/60/1	12	2395	Country Specific

1. VAC over the range \pm 10%

2. Maximum amp draw

3. Refer to chiller's nameplate for additional information

Approved Fluids

5°C to 95°C — Distilled Water or Deionized Water (up to 3 MΩ-cm)

Normal tap water leads to calcareous deposits necessitating frequent chiller decalcification. Calcium tends to deposit itself on the heating element. The heating capacity is reduced and service life shortened.

-25°C to 80 °C — 50/50 Water with Laboratory Grade Ethylene Glycol

Refer to Section 3 for additional information.

Wetted Materials

Viton Stainless Steel 316

EPDM Stainless Steel 304

Ryton Ryton

Ultem

Vectra

Section 3 Installation

The desk-top chiller is designed for continuous operation and for indoor use.



The chiller is not designed to be floor-mounted. ▲



Never place the chiller in a location where excessive heat, moisture, inadequate ventilation, or corrosive materials are present. ▲



Leave chillers in an upright position at room temperature (~25°C) for 24 hours before starting. This ensures the lubrication oil has drained back into the compressor. ▲

Ventilation

The chiller requires clean air for proper operation. Air enters from the rear of the chiller and exits through the sides and front.

The chiller is design to allow blocking of any two sides (except rear) without affecting rated load. The ambient temperature is reduced by 3°C if two sides are blocked.

Electrical Requirements



The chiller's construction provides protection against the risk of electrical shock by grounding appropriate metal parts. The protection will not function unless the power cord is connected to a properly grounded outlet. It is the user's responsibility to assure a proper ground connection is provided. ▲

The chiller is intended for use on a dedicated outlet. All chillers are equipped with a C14 main power inlet and a 20 Amp circuit protector.

Note If the circuit protector activates allow the chiller to cool before resetting the protector. Restart the chiller. Contact us if it activates again. ▲



The chiller's power cord is the electrical disconnecting device, it must be easily accessible at all times. ▲



Operate the chiller using only the supplied line cord, never operate equipment with damaged cords. ▲



Refer to the nameplate on the rear, upper-left-hand corner of the chiller for specific electrical requirements. Voltage range deviations of $\pm 10\%$ are permissible. The outlet must be rated as suitable for the total power consumption of the chiller.

Plumbing Requirements



Ensure that all shipping plugs are removed before installation.

Never connect the process fluid lines to your facility water supply or any pressurized liquid source. ▲

The process fluid connections are located on the rear of the chiller and are labeled  (PROCESS OUTLET) and  (PROCESS INLET).

Connect the PROCESS OUTLET  to the fluid inlet on your application.

Connect the PROCESS INLET  to the fluid outlet on your application.

Connect the reservoir overflow  to a suitable drain.

Ensure all connections are secure.

Keep the distance between the chiller and the instrument being cooled as short as possible. To minimize back pressure, ensure tubing is as straight as possible. If diameter reductions are required, make them at the inlet and outlet of your application, not at the chiller.

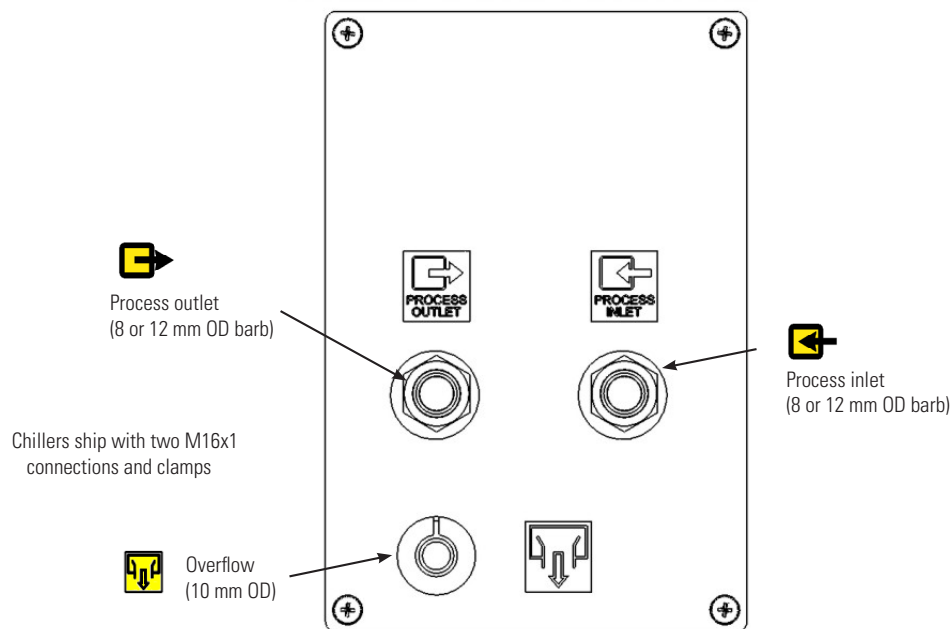

To prevent damage to the chiller's plumbing, use a 19 mm backing wrench when removing/installing the external connections. ▲

Fluid Considerations



Only use the approved fluids listed on the next page. Never use corrosive fluids with this chiller. ▲



Handle and dispose all liquids, other than water, in accordance with the fluid manufacturers specification and/or the fluid MSDS. ▲



Always adjust the chiller's software to the fluid used, see Section 4. ▲



Water/ethylene glycol mixtures require top-offs with pure water, otherwise the percentage of glycol increases resulting in high viscosity and poor performance. ▲

Thermo Fisher Scientific takes no responsibility for damages caused by the selection of an unapproved fluid.

Unapproved fluids are fluids which:

- are very highly viscous (much higher than 30 mPas at the respective working temperature)
- have corrosive characteristics or
- tend to break down at high temperatures

For fluid selection consider application requirements, operating temperature range, material compatibility, safety concerns, and environmental issues.

Chlorine

Short term usage of tap water may not cause any adverse affects on the chiller or your application, but in the long term problems may arise. To help alleviate these problems Thermo Fisher Scientific recommends the use of chlorine.

The duration of time that chlorine remains in solution depends on factors such as water temperature, pH and availability of direct sunlight. We recommend maintaining chlorine levels at proper levels using chlorine test strips, generally 1 to 5 ppm is adequate.

For best results, maintain the pH of the fluid between 6.5 and 7.5. Don't add additional chlorine without first determining the concentration ratio that already exists in the fluid supply. Corrosion and degradation of the circulation components can result from concentration ratios that are too high. Contact our customer support for additional information.

Approved Fluids

Distilled Water or Deionized Water (up to 3 MΩ-cm)

Normal tap water leads to calcareous deposits necessitating frequent chiller decalcification, see table on next page. Calcium tends to deposit itself on the heating element. The heating capacity is reduced and service life shortened.

50/50, by volume, Water with Laboratory Grade Ethylene Glycol

Below 5°C water has to be mixed with a glycol. The amount of glycol added should cover a temperature range 5°C lower than the operating temperature of the particular application. This prevents the water/glycol from gelling (freezing) near the evaporating coil.

50% ethylene glycol by volume is the maximum recommendation. Excess glycol deteriorates the temperature accuracy due to its high viscosity.

All our heat transfer fluids are supplied with an EC Safety Data Sheet.



When selecting the heat transfer fluid ensure that no toxic gases can be generated. Inflammable gases can build up during usage. ▲

Water Quality and Standards

Process Fluid	Permissible (PPM)	Desirable (PPM)
Microbiologicals		
(algae, bacteria, fungi)	0	0
Inorganic Chemicals		
Calcium	<25	<0.6
Chloride	<25	<10
Copper	<1.3	<1.0
	0.020 ppm if fluid in contact with aluminum	
Iron	<0.3	<0.1
Lead	<0.015	0
Magnesium	<12	<0.1
Manganese	<0.05	<0.03
Nitrates\Nitrites	<10 as N	0
Potassium	<20	<0.3
Silicate	<25	<1.0
Sodium	<20	<0.3
Sulfate	<25	<1
Hardness	<17	<0.05
Total Dissolved Solids	<50	<10
Other Parameters		
pH	6.5-8.5	7-8
Resistivity	0.01*	0.05-0.1*

* MΩ-cm (compensated to 25°C)

Unfavorably high total ionized solids (TIS) can accelerate the rate of galvanic corrosion. These contaminants can function as electrolytes which increase the potential for galvanic cell corrosion and lead to localized corrosion such as pitting. Eventually, the pitting becomes so extensive that refrigerant leaks into the water reservoir.

As an example, raw water in the United States averages 171 ppm (of NaCl). The recommended level for use in a water system is between 0.5 to 5.0 ppm (of NaCl).

Recommendation: Initially fill the tank with distilled or deionized water. Do not use untreated tap water as the total ionized solids level may be too high. This reduces the electrolytic potential of the water and prevent or reduce the galvanic corrosion observed.

Filling Requirements



Before using any fluid refer to the manufacturer's MSDS and EC safety data sheets for handling precautions. ▲

Note Ensure the reservoir overflow located on the rear of the chiller is connected to a suitable drain. ▲

Start with 2.8 liters of fluid.

Lift up on the fill panel on the front of the chiller to remove it.

Insert the supplied funnel into the hose and *slowly* add fluid.

Note Due to the chiller's plumbing configuration, adding fluid too quickly may result in overfilling - the fill level indication lags the actual amount added. ▲



When pouring fluid into the funnel ensure the fluid contacts the side of the funnel first, A. Pouring the fluid into the center of the funnel, B, causes air pockets and substantially slows down the filling time.

Using the fill lines, verify the desired fluid level.

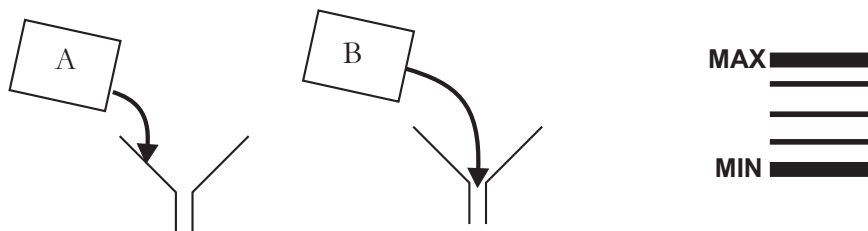

Since the reservoir capacity may be small compared to your application, and air may need to be purged from the lines, have extra cooling fluid on hand to keep the system topped off when external circulation is started.



Avoid overfilling, fluids expand when heated. ▲

Draining



Before draining any fluid refer to the manufacturer's MSDS and EC safety data sheets for handling precautions. ▲



Ensure the fluid is at a safe handling temperature (~40°C). Wear protective clothing and gloves. ▲

Lift up on the fill panel on the front of the chiller to remove it.

Pull the fill hose off the clips securing it to the chiller.

Keep your thumb on the end of the hose until ready to drain the fluid into a suitable container.



Storage



If the chiller is to be transported and/or stored in cold temperatures it needs to be drained and then flushed with a 50/50 laboratory grade glycol/water mixture. ▲

The chiller can be stored for up to 90 days inside the temperature range of -20°C to +60°C (-4°F to +140°F).

If necessary, when removing the chiller from storage allow it time to warm up and dry out in order to prevent any condensation issues.

Section 4 Operation

Controller

The Thermo Scientific Accel Series of chillers have a digital display and easy-to-use touch pad, five programmable setpoint temperatures, acoustic and optical alarms and adjustable high temperature protection.

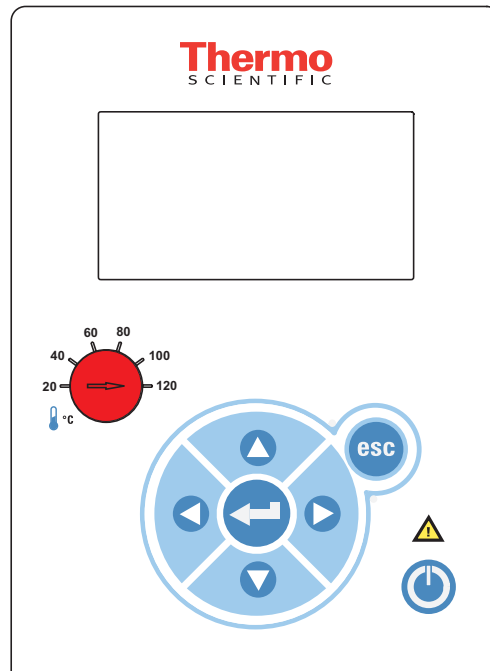

This label indicates read the instruction manual before starting the chiller.



Use this button to place the chiller in and out of stand by.



Use these navigation arrows to move through the controller displays and to adjust values.



Use this button to start/stop the chiller. This button is also used to make and save changes on the controller's display screen.



Use this button to cancel any changes and to return the controller to its previous display. Canceling a change can only be made before the change is saved. In some cases, it is also used to save changes.

Note Holding this button for five seconds resets the display contrast to the default level and also brings up the language menu to change, if needed, the displayed language. See **Settings - Display Options** in this Section. ▲



Use the adjacent dial for adjusting the High Temperature Cutout. Details are explained in the end of this Section.

Setup



Leave the chiller in an upright position at room temperature (~25°C) for 24 hours before starting. This ensures the lubrication oil has drained back into the compressor. ▲





Before starting the chiller, double check all USB, electrical and plumbing connections. ▲

Start Up

Do not run the chiller until fluid is added. Have extra fluid on hand. If the chiller does not start refer to Section 5 Troubleshooting.

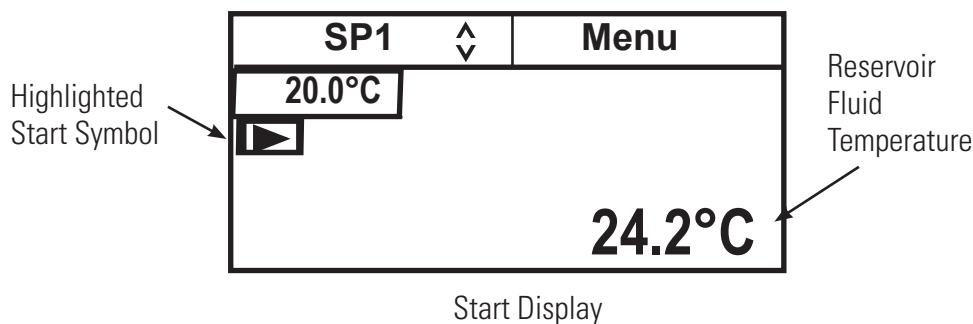
- Place the circuit protector located on the front of the chiller to the **I** position.
- Press , the Start Display appears
- Ensure the start symbol has a highlight box around it, if not use the arrow keys to navigate to the symbol.



- Press . The chiller starts and the start symbol turns into a stop symbol (■).



Note It takes 30 seconds for the compressor to start. ▲

Note After start, check external plumbing connections for leaks. ▲

The **SP1** and **Menu** portions on the top of the display are used to view and/or change the controller's settings. They are explained in detail later in this Section.

Status Display

If desired, press  to toggle between the Start/Status Displays.

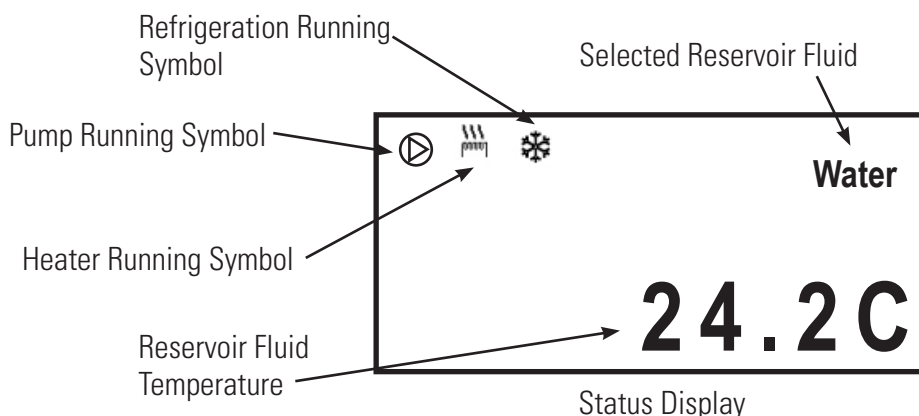



Stand By Mode

Press , the chiller enters the stand by mode.

Stopping the Chiller

Ensure the stop symbol is highlighted, if not use the arrow keys to navigate to the symbol.

Press . The chiller stops and the stop symbol turns into a start symbol ().

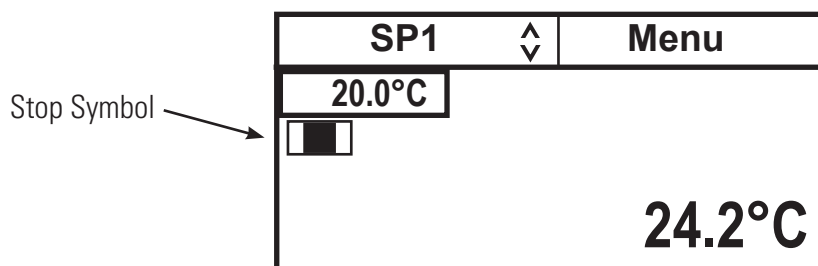

Power Down

Press , the chiller enters the stand by mode.

Shut Down

Place the circuit protector on the front of the chiller to the  position. The display goes blank.



Using any other means to shut the chiller down can reduce the life of the compressor. ▲



Always turn the chiller off and disconnect it from its supply voltage before moving the chiller. ▲



The circuit protector located on the front of the chiller is not intended to act as a disconnecting means. ▲

Restarting

Note When quickly restarting, the compressor may take up to 10 minutes before it starts to operate. Limit chiller cycling to 8 times/hour. ▲

Changing the Setpoint

Note You cannot adjust the setpoint closer than 0.1°C to either of the fluid's system limits, see Fluids Type in this Section, or beyond the chiller's temperature range. ▲

Note The setpoint can be changed with the chiller running or not. ▲

The setpoint is the desired fluid temperature. The controller can store up to five setpoints, **SP1** through **SP5**. The procedure for changing the stored setpoint values is discussed later in this Section.

Use the navigation arrows and move to the setpoint window and then press  to highlight it and the value window as shown below.

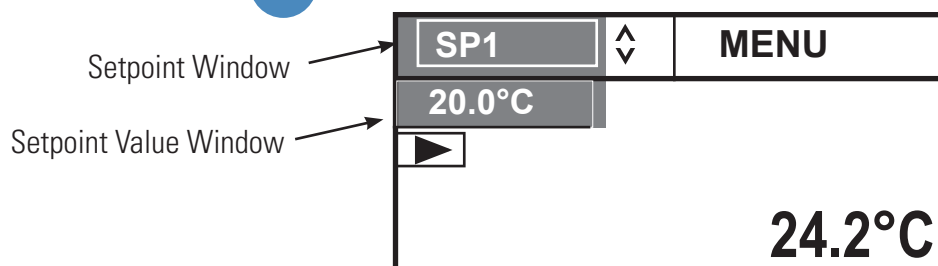

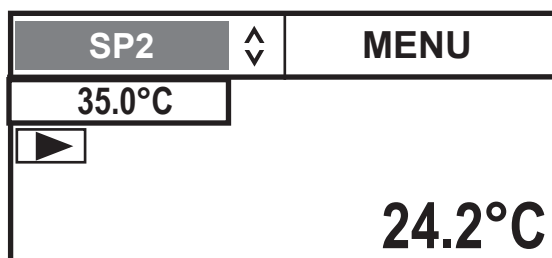

Use the up and down navigation arrows to bring up the desired setpoint and then press .

The display on the Setpoint Value Window now indicates the corresponding setpoint's stored value.

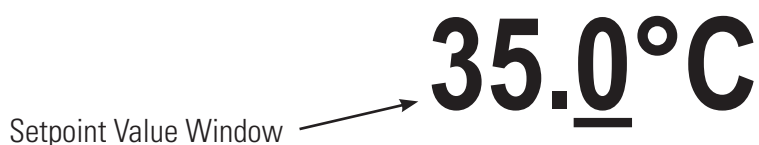

If desired, you can change the displayed setpoint value by using the navigation arrows to highlight the Setpoint Value Window and then pressing . The right-most digit has a cursor beneath it.





Use the left and right arrows to move the cursor to the desired digit and then use the up and down arrows to change the value. Once all the desired changes are made, press  to save the change.

Note Using this procedure also changes the setpoint's stored value.

Menu Displays

The controller uses menus to view/change the chiller's settings.

Note The chiller does not need to be running to view/change these settings. ▲

For all **Menu** displays, once  is pressed to change a display, you can press  to return to the previous screen.

1. Use the arrow buttons to highlight **Menu** and the controller brings up the Main Menu Display.

SP1	↑ ↓	Menu
Settings		^
System		
		v

2. Use the up and down arrow to highlight either **Settings** or **System** and then press  to bring up additional submenus.

Application Settings	^
Display Options	
	v
Menu	

See page 4-7.

SP1	↑ ↓	Menu
Settings		^
System		
		v

Messages	^
Run Time	
Configuration	
Password/Reset	v
Menu	

See page 4-12.

Menu

The **Menu** line, at the bottom of all the submenu displays, is another way to return the controller back to the Main Menu Display.

1. From any submenu display, use the down arrow button to highlight **Menu**.

2. Press  to return to the Start Display.

Application Settings	^
Display Options	
	v
Menu	

SP1	↑ ↓	MENU
20.0°C		
▶		
		24.2°C

Note Pressing  from the Menu line returns you to the previous screen. ▲

Menu Tree

Since the controller can only display five lines of text at a time, keep pressing the down arrow to view any additional options.

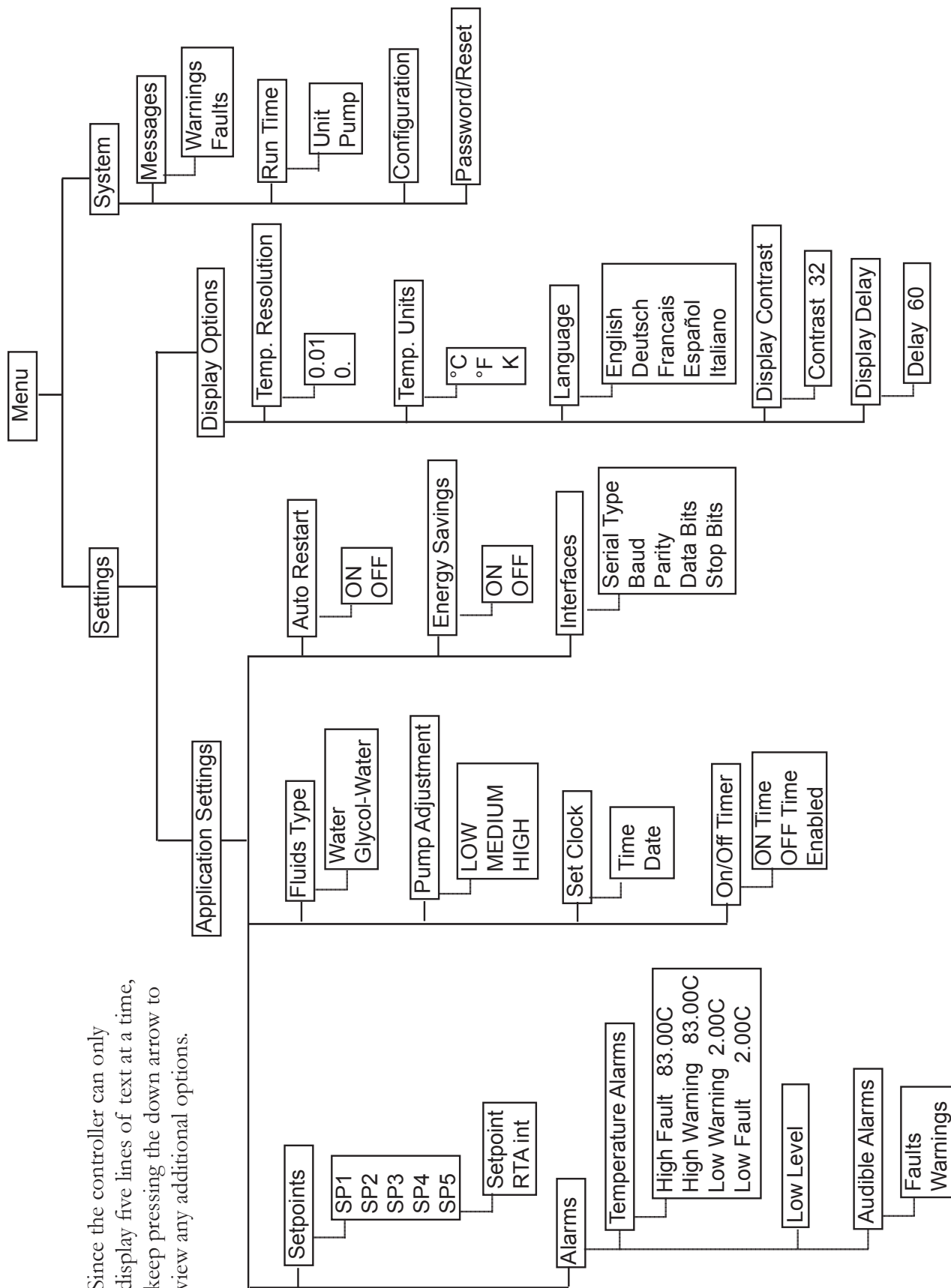

Settings - Application Settings is used to view/adjust the controller's five Setpoints and Real Temperature Adjustments (RTA), enable/disable the alarms, change the fluid type, set the pump speed, configure the interfaces (optional), set the clock, turn the timer on or off, and turn auto restart and energy savings on or off.

1. With **Application Settings** highlighted press  to view:

Setpoints	^
Alarms	
Fluid Type	
Pump Adjustment	v
Menu	

Scroll down for additional options:

Interfaces	^
Set Clock	
On/Off Timer	
Auto Restart	v
Menu	

2. With **Setpoints** highlighted, press  to display the list. Use the up/down arrows to highlight the desired **SP**. **Note** Use the down arrow to display **SP5**. ▲

SP1	^
SP2	
SP3	
SP4	v
Menu	

3. Press .

SP1	XX.X	^
RTA int	XX.X	
		v
Menu		

If the temperature on the Start/Status Displays do not accurately reflect the actual temperature in the reservoir, an RTA can be applied. The RTA can be set $\pm 10^{\circ}\text{C}$ ($\pm 18^{\circ}\text{F}$).

As an example, if the chiller's temperature is stabilized and displaying 20°C but a calibrated reference thermometer reads 20.5°C , set the RTA to -0.5°C . After you enter a RTA value allow chiller to stabilize before verifying the temperature. **Note** If display accuracy is required, we recommend repeating this procedure at various setpoint temperatures and on a regular basis. ▲

Note You cannot adjust the setpoint closer than 0.1°C to either of the fluid's system limits, see Fluids Type in this Section. ▲

4. With the desired line highlighted press .

The right-most digit has a cursor beneath it. Use the left and right arrows to move the cursor to the desired digit and then use the up and down arrows to change the value. Once all the desired changes are made, press  to save the change

or press  to cancel the change.

35.0°C

Alarms is used to view/adjust the high and low temperature alarm limits, to configure the low level reaction and to enable/disable the audible alarms.

1. With **Alarms** highlighted, press  to display:

Temperature Alarms	^
Low Level	
Audible Alarms	
	v
Menu	

2. With **Temperature Alarms** highlighted, press  to display:

High Fault	83.0°C	^
High Warn	83.0°C	
Low Warn	2.0°C	
Low Fault	2.0°C	v
Menu		

3. Highlight the desired limit and press . Follow the same procedure used to change a setpoint.



If the **Fault** temperature is exceeded the chiller shuts down and, if enabled, the audible alarm sounds. If the **Warn** temperature is exceeded the chiller continues to run and, if enabled, the audible alarm sounds. In both cases a message is displayed.

High Fault cannot be set below **High Warn**.
High Warn cannot be set below **Low Warn**.
Low Fault cannot be set above **High Warn**.

Press , or use the **Menu** window, to save and return to the previous display.

1. With **Low Level** highlighted, press  to display:

Level	Warning
Menu	

2. Press  and the display starts to flash, use the arrow keys to toggle between **Warning** and **Faults**. With the desired option showing press  again to stop the flashing.

A low level condition occurs when the fluid is approximately at the **MIN** reservoir level fill line. A low level condition can either generate a warning or a fault. With warning (the default setting) selected the chiller continues to run, with fault selected the chiller shuts down. In either case a message is displayed and, if enabled, sounds the alarm.

1. With **Audible Alarms** highlighted, press



to display the alarms.

Highlight the desired alarm and press  to toggle between enable and disable mode.

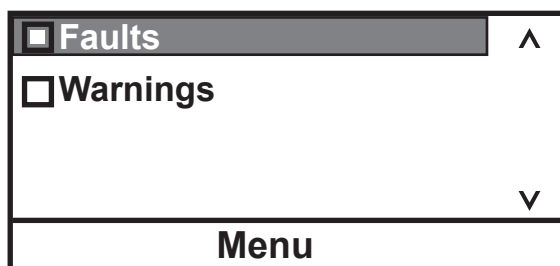

If **Faults** is enabled the alarm sounds when a fault occurs. If **Warnings** is enabled the alarm sounds when a warning occurs.

Press , or use the **Menu** window, to save and return to the previous display.

Fluids Type is used to identify the type of fluid used. The controller uses the fluid type to automatically set certain operating parameters.

1. With **Fluid Type** highlighted, press  to display the list of acceptable fluids.

Highlight the desired fluid and press  to select it.

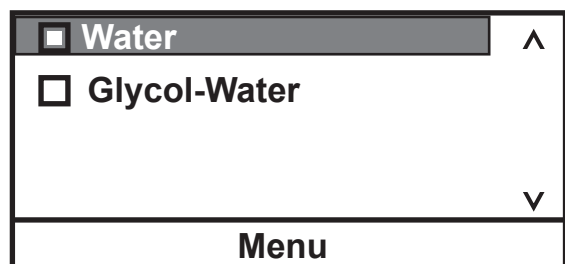

2. With the desired fluid selected press , or use the **Menu** window, to save and return to the previous display.

Pump Adjustment is used to review/set the desired pump speed. **Note** Force only pumps (FP1) have only two speeds, **High** and **Low**. ▲

1. With **Pump Adjustment** highlighted, press



to display the speeds.

Highlight the desired speed and press  to select it.

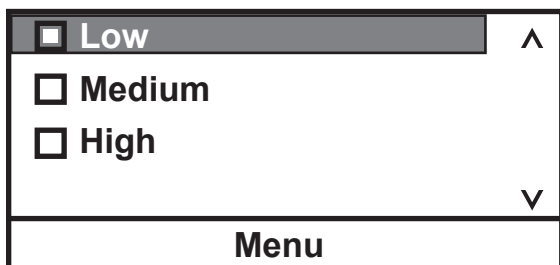

LC Fluid temperature alarm limits:		
	High °C/°F	Low °C/°F
Water	+83/+181	+2/+36
EG-Water	+83/+181	-13/+9
LT Fluid temperature alarm limits:		
	High °C/°F	Low °C/°F
Water	+83/+181	+2/+36
EG-Water	+83/+181	-28/-18
LT/HT Fluid temperature alarm limits:		
	High °C/°F	Low °C/°F
Water	+98/+208	+2/+36
EG-Water	+98/+208	-28/-18

Set Clock is used to set the controller's time (hr : min : sec) and date (year - month - day).

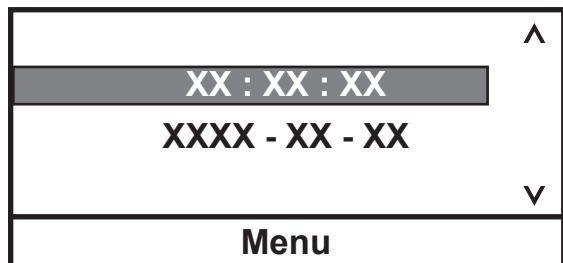

On/Off Timer is used to enable and set the controller's timer.

1. With **On/Off Timer** highlighted, press  to display the on (**I**) and off (**O**) time as well as the enable box.

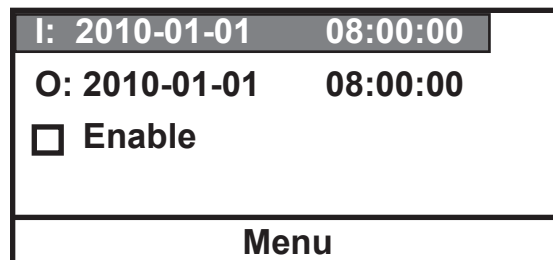

After setting the on and off times select **Enable** to activate the timer.

Auto Restart is used to enable the auto restart feature. When enabled, the chiller automatically restarts after a power failure or power interruption condition is restored. **NOTE** Consider any possible risks before enabling this mode of operation. ▲

1. With **Auto Restart** highlighted, press  to toggle between enable and disable.

Energy Saving is used to enable the energy savings mode. The Energy Saving mode is primarily designed for applications running under a stable load. Enabling the mode saves energy by reducing the chiller's heater power and cooling requirements. This can result in substantial energy savings over the life of the chiller. The default setting is **ON**.

1. With **Energy Saving** highlighted, press  to toggle between enable and disable.

Interfaces is used to enable/configure the optional communications feature. The controller supports AC, NC and Standard protocols.

1. With **Interfaces** highlighted, press  to display the list of parameters.

Highlight the desired parameter and press  to view the available options.

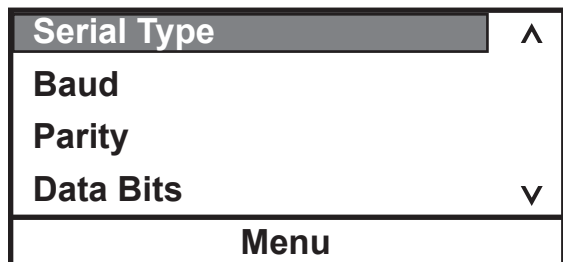



Available options:

Serial Type	USB, Off
Baud	19200, 9600, 4800, 2400, 1200, 600, 300
Parity	None, Odd, Even
Data Bits	8
Stop Bits	1, 2

See the Appendix for additional information.

Settings - Display Options is used to view/adjust the controller's Temperature Units, the Temperature Resolution, the displayed Language, the Display Contrast and the Display Delay.

1. With **Temp. Unit** highlighted press .
Use the up/down arrows to highlight the desired temperature scale. Press .

<input checked="" type="checkbox"/> °C	^
<input type="checkbox"/> °F	
<input type="checkbox"/> K	v
Menu	

2. With **Temp. Resolution** highlighted press .

Use the up/down arrows to highlight the desired resolution. Press .



<input type="checkbox"/> 0.01	^
<input checked="" type="checkbox"/> 0.1	
	v
Menu	

3. With **Language** highlighted press .
Use the up/down arrows to highlight the desired language. (Scroll down for additional languages.)

Press .

<input checked="" type="checkbox"/> English	^
<input type="checkbox"/> Deutsch	
<input type="checkbox"/> Francais	
<input type="checkbox"/> Español	v
Menu	

4. With **Display Contrast** highlighted press .

Press  again and use the up/down arrows keys to change the contrast. With the desired contrast showing, press  again.

Contrast	32	^
		v
Menu		

Note Holding  for five seconds resets the display contrast to the default level and also brings up the language menu to change, if needed, the displayed language. ▲

5. With **Display Delay** highlighted press  to enable/disable it.

Use the up/down arrows to highlight the time and press  again.

Use the up/down arrows to change the value. Once the desired delay is displayed press .

<input checked="" type="checkbox"/> Delay	^
60 sec	v
Menu	

With **Display Delay** enabled and the Start Display showing, if no arrows are pressed the Start Display changes to the Status Display after the delay expires. See pages 4-2 and 4-3.

System

SP1	^	Menu	
Settings			^
System			
			v

Messages	^
Run Time	
Configuration	
Password/Reset	v
Menu	

Messages is used to view any **Warnings** or **Faults** messages.

1. With **Messages** highlighted, press  to display the options.

Warnings	^
Faults	
	v
Menu	

Run Time is used to view the chiller (**Unit**) and **Pump** operating hours.

1. With **Run Time** highlighted, press  to display the times.

Unit	xxx hours	^
Pump	xxx hours	
		v
Menu		

Configuration is used to view the chiller's configuration.

1. With **Configuration** highlighted, press  to display the settings.

Pump	FPXXX
FW	XXXXXXXX.A
Checksum	XXXX
Bath	ACL250; 115V
FW	XXXXXXXX.A
Menu	

Pump options:

- FP1LE** Force Pump, Low Level
- FP2LE** Force/Suction Pump, Low Level
- FP1ULE** Force Pump, USB, Low Level
- FP2ULE** Force/Suction Pump, USB, Low Level
- FP2ULEHT** Force/Suction Pump, USB, Low Level, High Temp

Password/Reset is used only by a qualified technician. Changing the password enables controller reset options, the temperature sensor calibration procedure and displays PID values.

1. With **Password/Reset** highlighted, press  to display:

Level	User	^
Password	0	
		v
Menu		

2. Press  and change the number to **1**.

Level	User	^
Password	1	
		v
Menu		

3. Press  to display:

Level	Operator	^
Password	1	
Reset		
Calibration		v
Menu		

Note The controller defaults to the **User** mode whenever the chiller is turned off. The controller also defaults to the **User** mode whenever the Start/Status Display is displayed continuously for 10 minutes. ▲

Scroll down to display **PID Tuning**.

1. If desired, highlight **Reset** and press  to display:

Reset user settings	^
Reset PID settings	
Reset Both	
	v
Menu	

Highlight the desired reset option and press .

A confirmation message appears, press  again. The controller enters the stand by mode.

1. To calibrate the temperature sensor highlight **Calibration** and press  to display:

Internal RTD	^
v	
Menu	

3. Press  to display:

Internal RTD	xx.x	^
High	xx.x	
Low	xx.x	
Calibrate	SP	xx.x v
Menu		

5. Depending on which end you are calibrating highlight **High** or **Low**. Once the **Internal RTD** temperature stabilizes enter the temperature displayed on your reference thermometer and press .

Internal RTD	xx.x	^
High	xx.x	
Low	xx.x	
Calibrate	SP	xx.x v
Menu		

7. Repeat for the low end setpoint.

Internal RTD	xx.x	^
High	xx.x	
Low	xx.x	
Calibrate	SP	xx.x v
Menu		

2. Press  to display:

Calibrate	^
Restore User Cal	
Save User Cal	
Restore Factory Cal	v
Menu	

4. Highlight the **SP** temperature box and enter either the desired high end or low end setpoint value and press .

Internal RTD	xx.x	^
High	xx.x	
Low	xx.x	
Calibrate	SP	xx.x v
Menu		

6. Highlight **Calibrate** and then press  to complete the high end procedure.

Internal RTD	xx.x	^
High	xx.x	
Low	xx.x	
Calibrate	SP	xx.x v
Menu		

Once complete you can store the calibration into memory by selecting **Save User Cal** and pressing .

You can later restore the same calibration by highlighting **Restore User Cal** and pressing



Another option is to restore the factory calibration values by highlighting **Restore Factory Cal** and pressing .

PID Tuning is used to view/change the controller's PID values. **Note** We recommend only a qualified technician change the values, incorrect values impedes chiller performance. ▲

1. With **PID Tuning** highlighted, press  to display:

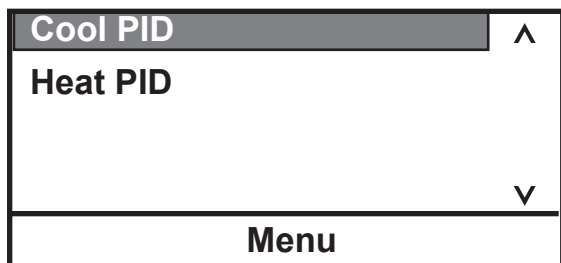

2. Highlight the desired PID and press  to display:

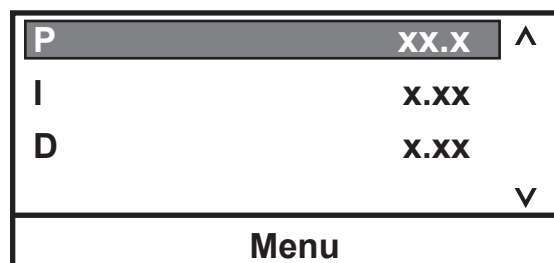

3. If required, press  to change the value.

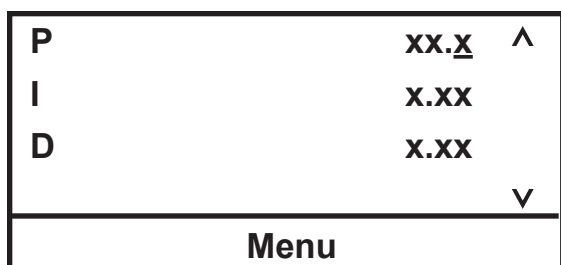

Factory values are:

P = 05.0

I = 0.10

D = 0.00

High Temperature Cutout

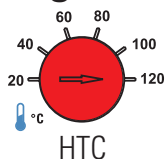

To protect your application, the adjustable High Temperature Cutout (HTC) ensures the heater does not exceed temperatures that can cause serious damage. A temperature sensor is located in the reservoir. A HTC fault occurs when the temperature of the sensor exceeds the set temperature limit.

In the event of a fault the chiller shuts down and the controller displays a fault message, see Section 6. The cause of the fault must be identified and corrected before the chiller can be restarted.

The HTC is not preset and must be adjusted. To set the cutout, with the chiller off use a flat head screwdriver to turn the red dial fully clockwise. Start the chiller. Adjust the setpoint for a few degrees higher than the highest desired fluid temperature and allow the chiller to stabilize at the temperature setpoint. Then slowly turn the red dial counterclockwise until the chiller shuts down and the fault message appears. Press the enter key to clear the message.

Before you can restart the chiller it has to cool down a few degrees. To restart the chiller press the black ring surrounding the red dial - and then press the enter key again. If Auto Restart is enabled the chiller restarts, if disabled use the Start Up procedure.

Note: We recommend periodically rechecking operation or if the chiller is moved. ▲

Section 5 Preventive Maintenance



Laboratory Grade Ethylene glycol (EG) is poisonous and flammable. Before performing any preventive maintenance refer to the manufacturer's most current MSDS for handling precautions. ▲



Disconnect the power cord prior to performing any maintenance. Ensure chiller is at a safe temperature before handling. ▲



Handle the chiller with care. Sudden jolts or drops can damage its components. ▲

There are no user serviceable components within the equipment cabinet. Only Thermo Fisher should provide required replacement parts listed below.

Cleaning

Clean the chiller's surface with a soft cloth and warm water only.

Condenser

Clean the condenser by running a vacuum over the grid on the lower rear section of the chiller.



Failure to clean the condenser will cause a loss of cooling capacity and lead to premature failure of the cooling system. ▲

Clean/replace the optional condenser filter.

Fluid Maintenance

Check the fluid level, concentration and pH on a regular basis, see Section 3. Change the fluid if it is discolored.

Sight Tube

As required, clean the sight tube using a small soft brush.

Hoses

Inspect and tighten the chiller's external hoses and clamps daily

Testing the Safety Features

The safety features for low fluid level protection and high fluid temperature must be checked at regular intervals. The frequency depends on the chiller's designated application and the heat transfer fluid used.

Low liquid level protection

With the chiller on, slowly drain the reservoir fluid (use a drainage tap if necessary) and ensure the controller displays a message and the chiller reacts as desired.

If not, have the chiller checked by qualified a technician.



High temperature protection

Using a flat-head screw driver, set a cut-off temperature that is lower than the desired setpoint temperature.

Switch on the circulator and ensure the chiller shuts down at the set cut-off temperature. Press the black ring surrounding the dial to reset the HTC.

If the chiller does not shut down have it checked by a qualified technician.

Reset the safety to the desired temperature.

Decommissioning/ Disposal



Decommissioning prepares equipment for safe and secure transportation.

Laboratory Grade Ethylene glycol (EG) is poisonous and flammable. Before disposing refer to the manufacturer's most current MSDS for handling precautions. ▲



Handling and disposal should be done in accordance with the manufacturers specification and/or the MSDS for the material used. ▲



Decommissioning must be performed only by qualified dealer using certified equipment. All prevailing regulations must be followed. ▲

Consider decommissioning the chiller when:

- It fails to maintain desired specifications
- It no longer meets safety standards
- It is beyond repair for its age and worth

Refrigerant (R134A) and oil (Polyol Ester) must be recovered from equipment before disposal.

Note Keep in mind any impact your application may have had on the chiller. ▲

Direct questions about chiller decommissioning or disposal to our Sales, Service and Customer Support.

Section 6 Troubleshooting

Error Displays

Error messages are cleared by pressing the enter key (↵). Once the cause of the error message is identified and corrected, to restart the chiller - on chillers with an HTC error press the black ring surrounding the red dial - and then for all chillers press the enter key again. If **Auto start** is enabled the chiller restarts, if disabled use the Start Up procedure.

<p>FAULT: HTC HIGH TEMP. CUTOUT- PRESS ENTER</p>
--

Error Message (Typical)

Fault Displays

The heating element, pump and, if applicable, refrigeration shut down with a fault. A fault also sounds the alarm, if enabled.

Message	Action
High Fixed Temp.	<ul style="list-style-type: none"> • chiller's nonadjustable high temperature protection limit exceeded • check fluid selection • check environmental conditions
High Temperature	<ul style="list-style-type: none"> • adjustable high temperature protection limit exceeded • check limit setting • check fluid selection • ensure chiller has adequate ventilation
High Temperature Refrigeration	<ul style="list-style-type: none"> • check voltage supply • the refrigeration may need servicing
HPC High Press. Cutout	<ul style="list-style-type: none"> • check for obstructions to air flow • the refrigeration may need servicing
HTC High Temp. Cutout	<ul style="list-style-type: none"> • high temperature protection limit exceeded • check limit setting • allow chiller to cool down • reset HTC by pressing black ring
LLC Low Level Cutout	<ul style="list-style-type: none"> • reservoir fluid level too low for safe operation • check fluid level • check for leaks

Low Fixed Temp.	<ul style="list-style-type: none"> • chiller's nonadjustable low temperature protection limit exceeded • check fluid selection
Low Temperature	<ul style="list-style-type: none"> • adjustable high temperature protection limit exceeded • check limit setting • check fluid selection
Motor Fault	<ul style="list-style-type: none"> • it can take over 10 minutes for the motor temperature to get low enough before the chiller can be restarted
MOL Motor Overload	<ul style="list-style-type: none"> • allow chiller to cool down
Open RTD1 Internal	<ul style="list-style-type: none"> • open internal temperature sensor
Open RTD2 External	<ul style="list-style-type: none"> • open external temperature sensor
Shorted RTD1 Internal	<ul style="list-style-type: none"> • shorted internal temperature sensor
Shorted RTD2 External	<ul style="list-style-type: none"> • shorted external temperature sensor

Warning Displays

The chiller continues to run with a warning. A warning also sounds the alarm, if enabled.

Bad Calibration	<ul style="list-style-type: none"> • redo calibration
High Temperature	<ul style="list-style-type: none"> • adjustable high temperature protection limit exceeded • check limit setting • check fluid selection
Low Level	<ul style="list-style-type: none"> • reservoir fluid level too low for safe operation • check fluid level
Low Temperature	<ul style="list-style-type: none"> • adjustable low temperature protection limit exceeded • check limit setting • check fluid selection

Checklist

Chiller will not start

Check the controller for error displays, see Error Displays in this section.

Ensure the circuit protector is in the on (I) position.

Make sure supply voltage is connected and matches the chiller's nameplate rating $\pm 10\%$.

No display on controller

Cycle the circuit protector on the front of the chiller.

Chiller will not circulate process fluid

Check the reservoir level. Fill, if necessary.

Check the application for restrictions in the cooling lines.

The pump motor overloaded. The pump's internal overtemperature overcurrent device shuts off the pump causing the flow to stop. This can be caused by low fluid, debris in system, operating chiller in a high ambient temperature condition or excessively confined space. Allow time for the motor to cool down.

Make sure supply voltage matches the chiller's nameplate rating $\pm 10\%$.

Inadequate temperature control

Verify the setpoint.

Make sure the condenser and the optional filter are free of dust and debris.

Check the fluid concentration.

Ensure chiller installation complies with the site requirements in Section 3.

Make sure supply voltage matches chiller nameplate rating $\pm 10\%$.

If the temperature continues to rise, make sure your application's heat load does not exceed the rated specifications.

Check for high thermal gradients (e.g., the application load is being turned on and off or rapidly changing).

Chiller shuts down

Ensure  button wasn't accidentally pressed.

Ensure the circuit protector is in the on (I) position.

Check the controller for error displays.

Make sure supply voltage is connected and matches the chiller's nameplate rating $\pm 10\%$.

Restart the chiller.

USB Driver Not Recognized

If your operating system does not automatically recognize the USB driver log on to:

<http://www.ftdichip.com/FTDrivers.htm>

for instructions.

Appendix AC Serial Communications Protocol

Serial communication is accomplished through the USB port on the chiller. If your operating system does not automatically recognize the optional driver log on to: <http://www.ftdichip.com/FTDrivers.htm> for instructions.

Note This appendix assumes you have a basic understanding of communications protocols. Information on the NC, STANDARD and NAMUR protocols is available upon request. ▲

Note Controller operation is still available with serial communications enabled. ▲

All commands must be entered in the exact format shown in the tables on the following pages. The tables show all commands available, their format and responses. Chiller responses are either the requested data or an error message. The chiller response must be received before the host sends the next command.

The host sends a command embedded in a single communications packet, then waits for the chiller's response. If the command is not understood, the chiller responds with an error command. Otherwise, the chiller responds with the requested data.

Commands are not case sensitive. Upper or lower case letters may be used. Commands are listed in the Commands Table, error responses are given in the Errors Table, and symbols are shown in the Key Table.

Key	
Symbol	Meaning
[B]	A binary value 0 or 1 (0 = Off, FALSE or Disable(d); 1 = On, TRUE or Enable(d)).
[CR]	Carriage return – used as the termination character.
[U]	Text representing the units associated with a value.
[V]	A value that can be requested in a read command or sent as part of a set command.
[V _{MAX}]	Maximum allowed value. Part of error message when set value is too high.
[V _{MIN}]	Minimum allowed value. Part of error message when set value is too low.

Value: Read commands return analog [V] or bit [B] values or settings, while set commands send analog or bit settings. Read commands return values with the same displayed precision. Set command messages missing the space character between the command and the setting will be rejected, as the user's intent is unclear.

Units: A read command returning an analog [V] value or setting, will include the units [U] associated with that value or setting. A set command sending an analog value will not include the units. The units returned by the complementary read command are assumed.

Termination character: A carriage return [CR] is used to terminate command and response messages. (Typically the "Enter" key on the keyboard.)

Note The inter-character timeout (time between transmitted characters) is set to 30 seconds. Exceeding the timeout clears the receiver buffer and requires the message to be retransmitted.

Note Special characters (backspace, delete, insert, etc.) are not recognized by the protocol and generate error responses.

Commands Table:

Commands		<i>All messages from master and slave are terminated with a carriage return [CR]</i>	
Command Description	<i>Notes</i>	Master Sends	Sample Slave Response <i>(echo off)</i> <i>Alternate units</i>
Read Temperature	<i>Internal</i>	RT	[V]C F K
Read Displayed Setpoint		RS	[V]C F K
Read Setpoint X (X = 1 to 5)		RSX	[V]C F K
Read Internal RTAX (X = 1 to 5)		RIRTAX	[V]C F K
Read High Temperature Fault		RHTF	[V]C F K
Read High Temperature Warn		RHTW	[V]C F K
Read Low Temperature Fault		RLTF	[V]C F K
Read Low Temperature Warn		RLTW	[V]C F K
Read Proportional Cool Band Setting		RPC	[V]%
Read Integral Cool Band Setting		RIC	[V]Repeats per minute
Read Derivative Cool Band Setting		RDC	[V]Minutes
Read Temperature Precision		RTP	[V]
Read Temperature Units		RTU	[V] C,F,K
Read Unit On		RO	[B]
Read Auto Restart Enabled		RAR	[B]
Read Energy Saving Mode		REN	[B]
Read Time		RCK	hh:mm:ss
Read Date		RDT	mm/dd/yyyy or dd/mm/yyyy
Read Date Format		RDF	mm/dd/yyyy or dd/mm/yyyy
Read Firmware Version		RVER	[V]
Read Firmware Checksum		RSUM	[V]
Read Unit Fault Status		RUFS	[V ₁ , V ₂ , V ₃ , V ₄ , V ₅] See page 5

Commands			
<i>All messages from master and slave are terminated with a carriage return [CR]</i>			
Command Description	Notes	Master Sends	Sample Slave Response <i>(echo off)</i> <i>Alternate units</i>
Set Displayed Setpoint		SS [V]	OK
Set Setpoint X (X = 1 to 5)		SSX [V]	OK
Set Internal RTA X (X = 1 to 5)		SIRTA X [V]	OK
Set High Temperature Fault		SHTF [V]	OK
Set High Temperature Warning		SHTW [V]	OK
Set Low Temperature Fault		SLTF [V]	OK
Set Low Temperature Warning		SLTW [V]	OK
Set Proportional Cool Band Setting		SPC [V]	OK
Set Integral Cool Band Setting		SIC [V]	OK
Set Derivative Cool Band Setting		SDC [V]	OK
Set Temperature Resolution		STR [V]	OK
Set Temperature Units		STU [V] C,F,K	OK
Set Unit On Status		SO [B]	OK
Set Auto Restart Enabled		SAR [B]	OK
Set Energy Saving Mode		SEN [V]	OK
Set Pump Speed		SPS [V] L,M,H	OK

Errors Table:

Errors		
Error Description	Notes	Slave Responds
<i>Not defined, not implemented or incorrectly formatted</i>		? Unsupported command
<i>Extra characters...</i>		? Format error
<i>Set value too high</i>		? Maximum allowed is $[V_{MAX}]$
<i>Set value too low</i>		? Minimum allowed is $[V_{MIN}]$
<i>Argument to binary set command not 0 or 1</i>		? Value must be 0 or 1
<i>Set command attempted while in read only mode</i>		? Mode is read only
<i>Set command failed (e.g. SO 1 with low level)</i>		? Failed

RUFS Read Unit Fault Status

This command returns 5 values. These are decimal representations of hexadecimal values. Each individual bit of the value represents a different warning, fault or status.

decimal	hex	B7	B6	B5	B4	B3	B2	B1	B0
1	1	0	0	0	0	0	0	0	1
2	2	0	0	0	0	0	0	1	0
4	4	0	0	0	0	0	1	0	0
8	8	0	0	0	0	1	0	0	0
16	10	0	0	0	1	0	0	0	0
32	20	0	0	1	0	0	0	0	0
64	40	0	1	0	0	0	0	0	0
128	80	1	0	0	0	0	0	0	0

Value	Description of bits
V_1	B0 - B5 unused B6 rtd1 shorted B7 rtd1 open
V_2	B0 HTC fault B1 high RA temperature fault B2 - B7 unused
V_3	B0 low level warn B1 lo temperature warn B2 high temperature warn B3 low level fault B4 lo temperature fault B5 high temperature fault B6 low temperature fixed fault B7 high temperature fixed fault
V_4	B0 PWM heat duty cycle > 0 B1 compressor On/Off B2 Pump On status B3 Unit On status B4 Unit Stopping B5 Unit fault status B6 unused B7 Beeper On status
V_5	B0 Pump speed fault B1 MOL fault B2 HPC fault B3 Cool Icon On steady (unit is cooling at max capacity) B4 Cool Icon flashing (unit is cooling) B5 Heat Icon On steady B6 Heat Icon flashing B7 External sensor controlling

Refer to Key table on page 1 for explanation of symbols and their meanings.

Examples:

Read Temperature:

Host

R	T		CR
Command			[CR]

Chiller:

2	0	.	0	C	CR
[V]			[U]	[CR]	

Set Setpoint:

Host

S	S		2	0	CR
Command			[V]	[CR]	

Chiller :

O	K	CR
Command Accepted		[CR]

Read Temperature 2:

Host:

R	T	2	CR	
2	0	.	0	C [CR]

Chiller:

Set Setpoint to -22°C when minimum allowed is -20°C: Minimum allowed is $[V_{MIN}]$

Host:

S	S		-	2	2	CR												
?	M i n i m u m a l l o w e d i s - 2 0 CR																	

Chiller:

DECLARATION OF CONFORMITY

Manufacturer: Thermo Fisher Scientific
Address: 25 Nimble Hill Road
Newington, NH USA 03801



Year of inception 2010

Products: Heated and Refrigerated Liquid Circulators.

We declare that the following products conform to the Directives and Standards listed below:

Thermo Fisher Scientific Accel models 250 & 500.

All rated :

1. 100 Volts, 50 Hz & 100 Volts, 60 Hz or
2. 115 Volts, 60 Hz or
3. 220 Volts, 60 Hz or
4. 220 - 230 Volts, 50 Hz

Equipment Class: Measurement, control and laboratory

Directives and Standards:

2004/108/EC – Electromagnetic Compatibility (EMC Directive):

EN 61326-1: 2006 – Electrical equipment for measurement, control, and laboratory use – EMC requirements, EMC Class A

2006/95/EC – Low Voltage Directive (LVD):

EN 61010-1: 2004 – Safety requirements for electrical equipment for measurement, control, and laboratory use – general requirements.

EN 61010-2-010: 2003 – Safety requirements for electrical equipment for measurement, control, and laboratory use – Part 2-010: Particular requirements for laboratory equipment for the heating of materials.

Manufacturer's Authorized Representative:

Date:



Mark Sinclair
R & D Manager

04 August 2011

RoHS DECLARATION OF CONFORMITY

Manufacturer: Thermo Fisher Scientific

Address: 25 Nimble Hill Road
Newington, NH USA 03801

Products: Thermo Fisher Scientific standard Accel models 250 & 500, heated and refrigerated liquid circulators.

Thermo Fisher Scientific certifies that Accel models 250 & 500 meet the requirements of DIRECTIVE 2002/95/EC, Restriction of Hazardous Substances Directive (RoHS) without exemptions. Thermo Fisher Scientific certifies that Accel models 250 & 500, contains less than the following amounts of the six RoHS banned substances:

Substance		Threshold Level
Lead...	Pb	Less than 0.1% ^{1 & 2}
Mercury...	Hg	Less than 0.1% ¹
Hexavalent Chromium ...	Cr (VI)	Less than 0.1% ¹
Polybrominated Biphenyls ...	PBB	Less than 0.1% ¹
Polybrominated Diphenyl Ethers ...	PBDE	Less than 0.1% ¹
Cadmium ...	Cd	Less than 0.01% ¹
Notes: 1. Tolerated maximum concentration value by weight in homogeneous materials. 2. Exemptions - Lead as an alloying element in steel containing up to 0.35% lead by weight, aluminum containing up to 0.4% lead by weight and as a copper alloy containing up to 4% lead by weight.		

Manufacturer's Authorized Representative:

Date:



Mark Sinclair
R & D Manager

04 August 2011

WARRANTY

Thermo Fisher Scientific warrants for 24 months from date of shipment the Thermo Scientific Accel chillers according to the following terms.

Any part of the chiller manufactured or supplied by Thermo Fisher Scientific and found in the reasonable judgment of Thermo Fisher to be defective in material or workmanship will be repaired at an authorized Thermo Fisher Repair Depot without charge for parts or labor. The chiller, including any defective part must be returned to an authorized Thermo Fisher Repair Depot within the warranty period. The expense of returning the chiller to the authorized Thermo Fisher Repair Depot for warranty service will be paid for by the buyer. Our responsibility in respect to warranty claims is limited to performing the required repairs or replacements, and no claim of breach of warranty shall be cause for cancellation or rescission of the contract of sales of any chiller. With respect to chiller that qualify for field service repairs, Thermo Fisher Scientific's responsibility is limited to the component parts necessary for the repair and the labor that is required on site to perform the repair. Any travel labor or mileage charges are the financial responsibility of the buyer.

The buyer shall be responsible for any evaluation or warranty service call (including labor charges) if no defects are found with the Thermo Scientific product.

This warranty does not cover any chiller that has been subject to misuse, neglect, or accident. This warranty does not apply to any damage to the chiller that is the result of improper installation or maintenance, or to any chiller that has been operated or maintained in any way contrary to the operating or maintenance instructions specified in this Instruction and Operation Manual. This warranty does not cover any chiller that has been altered or modified so as to change its intended use.

In addition, this warranty does not extend to repairs made by the use of parts, accessories, or fluids which are either incompatible with the chiller or adversely affect its operation, performance, or durability.

Thermo Fisher Scientific reserves the right to change or improve the design of any chiller without assuming any obligation to modify any chiller previously manufactured.

THE FOREGOING EXPRESS WARRANTY IS IN LIEU OF ALL OTHER WARRANTIES, EXPRESSED OR IMPLIED, INCLUDING BUT NOT LIMITED TO WARRANTIES OR MERCHANTABILITY AND FITNESS FOR A PARTICULAR PURPOSE.

OUR OBLIGATION UNDER THIS WARRANTY IS STRICTLY AND EXCLUSIVELY LIMITED TO THE REPAIR OR REPLACEMENT OF DEFECTIVE COMPONENT PARTS AND Thermo Fisher Scientific DOES NOT ASSUME OR AUTHORIZE ANYONE TO ASSUME FOR IT ANY OTHER OBLIGATION.

Thermo Fisher Scientific ASSUMES NO RESPONSIBILITY FOR INCIDENTAL, CONSEQUENTIAL, OR OTHER DAMAGES INCLUDING, BUT NOT LIMITED TO LOSS OR DAMAGE TO PROPERTY, LOSS OF PROFITS OR REVENUE, LOSS OF THE CHILLER, LOSS OF TIME, OR INCONVENIENCE.

This warranty applies to chillers sold in the United States. Any chiller sold elsewhere are warranted by the affiliated marketing company of Thermo Fisher Scientific. This warranty and all matters arising pursuant to it shall be governed by the law of the State of New Hampshire, United States. All legal actions brought in relation hereto shall be filed in the appropriate state or federal courts in New Hampshire, unless waived by Thermo Fisher Scientific.

Thermo Fisher Scientific
81 Wyman Street
P.O. Box 9046
Waltham, Massachusetts 02454-9046
United States

www.thermofisher.com

Thermo
SCIENTIFIC