

TURBOVAC i

TURBOVAC 850 i, 950 i

Turbomolecular Pumps with Integrated
Frequency Converter

Operating Instructions 300855170_002_C3

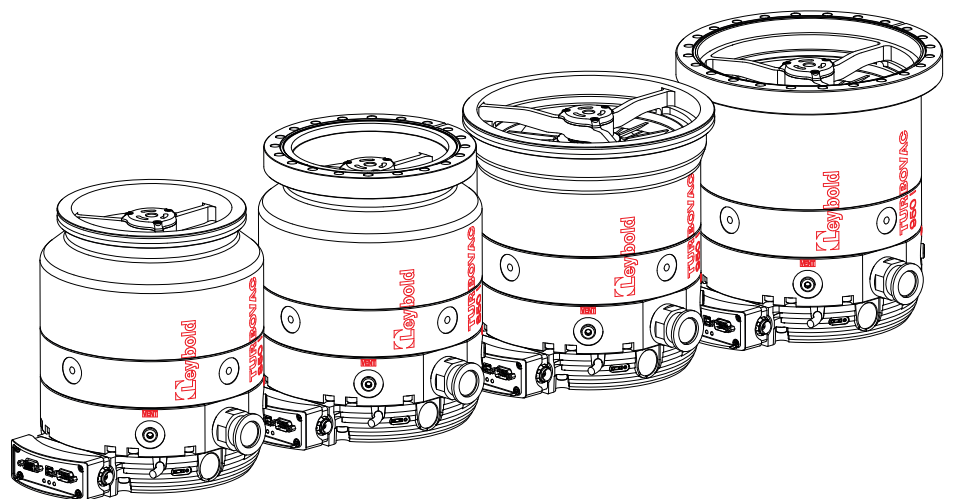
Part Nos.

840071V1000 /V2000

840081V1000 /V2000

840091V1000 /V2000

840111V1000 /V2000



Contents

	Page	
0	Important Safety Information	5
	Safety symbols	5
0.1	Mechanical hazards	6
0.2	Electrical hazards	7
0.3	Thermal hazards	7
0.4	Danger through materials and substances	7
0.5	Dangers in connection with safety-related measures and precautions	7
1	Description	8
1.1	Design	9
1.2	Standard equipment	9
1.3	Technical data	10
1.3.1	Technical data for the integrated drive electronics	11
1.4	Ordering data	12
1.5	Accessories	12
2	Transport and storing	15
3	Installation	16
3.1	Conforming utilization	16
3.1.1	Non-conforming utilization	16
3.2	Operating environment	17
3.3	Fitting accessories	17
3.4	Attach the pump to the vacuum chamber	18
3.5	Forevacuum connection	23
3.6	Connect the cooling	24
3.6.1	Air cooling	24
3.6.2	Water cooling	25
3.6.3	Water Quality	26
3.7	Connect a power failure venting valve or a venting valve	28
3.8	Connect purge gas	29
3.9	Connect a flange heater	30
3.10	Electrical connection	30

4	Operation	35
4.1	Media compatibility / purge gas	35
4.2	Interfaces	35
4.3	Switching on	37
4.4	Shutting down	38
4.5	Venting	39
4.6	Bakeout	40
4.7	Operation after a longer storage period	40
4.8	Removing the pump from the system	41
5	Maintenance	42
5.1	Cleaning	42
5.2	Leybold Service	42
6	Troubleshooting	43
7	Waste Disposal	45
	EU Declaration of Conformity	46

The TURBOVAC allows through both standard and optional interfaces controlling of the pump and setting up of some pump functions according to specific requirements. The Operating Instructions **300450826 Serial Interfaces for TURBOVAC i/iX** offers detailed information on the RS 232, RS 485, Profibus and USB interfaces of the TURBOVAC.

The Operating Instructions **300687441 TURBOVAC iX EtherCAT Interface** offers information on the EtherCAT Interface.

These Operating Instructions are a translation of the German original instructions 300855170_001_C3.

Safety Information

NOTICE



Obligation to Provide Information

Before installing and commissioning the pump, carefully read these Operating Instructions and follow the information so as to ensure optimum and safe working right from the start.

The Leybold **TURBOVAC** has been designed for safe and efficient operation when used properly and in accordance with these Operating Instructions. It is the responsibility of the user to carefully read and strictly observe all safety precautions described in this section and throughout the Operating Instructions. The pump must only be operated in the proper condition and under the conditions described in the Operating Instructions. It must be operated and maintained by trained personnel only. Consult local, state, and national agencies regarding specific requirements and regulations. Address any further safety, operation and/or maintenance questions to our nearest office.

“Trained personnel” for the operation of this pump are

- skilled workers with knowledge in the fields of mechanics, electrical engineering and vacuum technology and
- personnel specially trained for the operation of vacuum pumps.

WARNING



WARNING indicates a potentially hazardous situation which, if not avoided, could result in death or serious injury.

CAUTION



CAUTION indicates a potentially hazardous situation which, if not avoided, could result in minor or moderate injury.

NOTICE



NOTICE is used to notify users of installation, operation, programming or maintenance information that is important, but not hazard related.

We reserve the right to alter the design or any data given in these Operating Instructions. The illustrations are not binding.

Retain the Operating Instructions for further use.

0 Important Safety Information

Safety symbols

The safety symbols on the products shows the areas where care and attention is necessary.

The safety symbols that follow are used on the product or in the product documentation.



General warning sign



Warning vacuum



Warning of falling loads



Warning - Dangerous voltage



Warning - Hot surfaces



Warning - Risk of explosion

Safety Information

0.1 Mechanical hazards



WARNING: EJECTION OF PARTS

If the mounting is not sturdy enough, pump blockage could cause the pump to break loose; internal pump components could be thrown in all directions.

Mount the pump firmly to the vacuum chamber. Never operate the pump without proper flanging to the vacuum chamber (in bench testing, for example).

In case of rotor destruction a sudden twisting of the entire pump is possible. The vacuum chamber must be able to absorb the torque of max. 10 kNm around the rotor's axis of rotation in the event of sudden rotor destruction.



CAUTION: CUTTING AND CRUSHING

When reaching into open flanges there is a risk of cutting and crushing your fingers.

Do not operate the vacuum pump with open flanges. Do not reach into the pump.

When installing the vacuum pump, first mechanically connect the inlets and outlets and then make the electrical connections.

Disconnect the vacuum pump from the power supply before servicing. Only use trained service personnel.

Before servicing, ensure that gas cannot flow through the pump. Only open the pump system when it is under atmospheric pressure.



CAUTION: EJECTION OF PARTS

Ejection of parts through bursting of vacuum system as a result of excessive pressure.

When using the pump with purge gas, protect the purge gas supply such that in the event of a malfunction no overpressure can occur within the system. The pressure in the pump must not exceed 1.4 bar (absolute).



CAUTION: VACUUM

Pulling into the vacuum can cause injury to hands or fingers.

Do not operate the vacuum pump with open flanges.



CAUTION: FALLING PARTS

Errors during transport can cause the pump to fall down.

Transport the pump only in its transport packaging or at the eye-bolts provided for this purpose.

0.2 Electrical hazards



CAUTION: ELECTRICAL SHOCK

Contact with live parts may lead to electrical shock.

The electrical connection may only be carried out by a trained person. Observe the national regulations in the user country, e.g. for Europe EN 50110 - 1. Prior to servicing, disconnect the vacuum pump from the power supply.

Electrical shock due to interruption of the protective conductor system. In the event of a fault, life-threatening voltages may be present on electrically conductive components. Before commissioning, check the resistance of the earthing cable and the suitability of the assigned overcurrent protection device.

The pump must only be connected to power supplies which meet the requirements for functional extra-low voltages with positive isolation in accordance with IEC 60364-4-41 (or local regulations) (PELV). All interfaces must only be operated with PELV-fed components and devices.

0.3 Thermal hazards



CAUTION: BURNS

Touching hot surfaces may lead to burns.

Handle the pump only when ventilated and cooled down.
Wear suitable protective equipment.

0.4 Danger through materials and substances



WARNING: HAZARDOUS SUBSTANCES

Pumped process gases may escape from the exhaust and leaks in the vacuum system. During servicing, toxic deposits may be present in the pump. The gases, vapours or substances may be hazardous to health.

The pumping of toxic / explosive / flammable / pyrophoric / radioactive / oxidizing / corrosive gases or gas mixtures, as well as oxygen of more than atmospheric concentration (21 %) is generally prohibited. The operator is responsible for assessing the hazard potential of the process media or mixtures.

0.5 Dangers in connection with safety-related measures and precautions



CAUTION: AUTOMATIC START-UP

The frequency converter is not equipped with its own emergency shut down switch. This may lead to an unwanted pump start-up.

Install an emergency shut down switch in the system. The emergency shut down switch must be

- present in the building installation
- suitably arranged and easily accessible for the user
- marked as the disconnecting device for this device.

Description

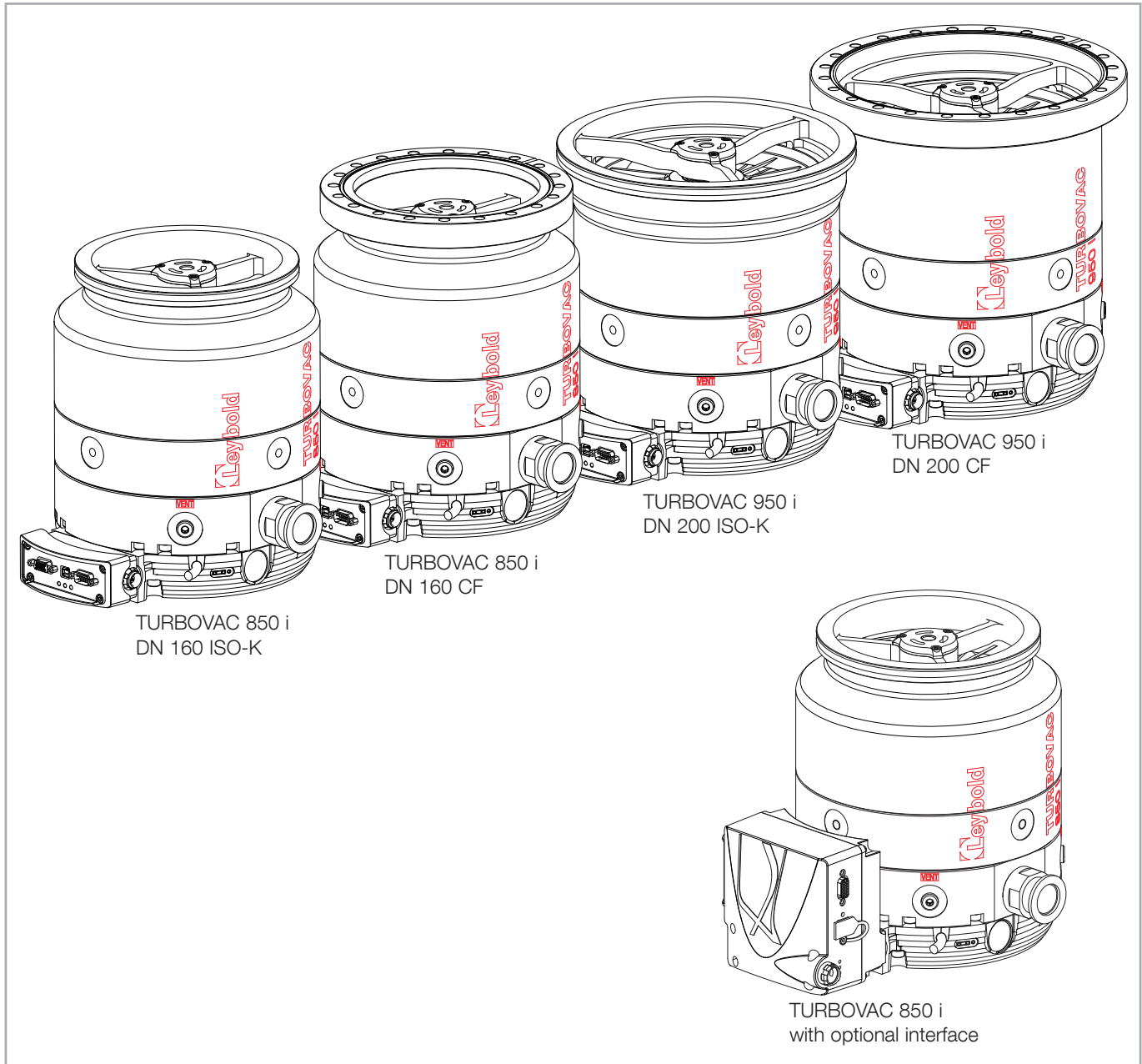


Fig. 1.1 TURBOVAC models

1 Description

The TURBOVAC 850 i and 950 i are turbomolecular pumps designed to evacuate vacuum chambers down to pressure levels in the high vacuum and ultra-high vacuum range.

They are suitable for pumping air and clean gases. A forevacuum pump and a power supply are required for their operation.

1.1 Design

The TURBOVAC models are wide-range TMPs equipped with an additional Holweck stage.

With the built-in frequency converter as the electronic drive the TURBOVAC forms one single unit. The electronic drive governs the pump's speed and serves as a monitor for all functions of the pump.

At the high vacuum side the bearing is of a non-wearing permanent magnetic bearing type, at the forevacuum side a lifetime lubricated oil-free ceramic ball bearing is used.

Water cooling or an air cooling fan is available as optional equipment.

The intake flange should be fitted with a wire mesh inlet screen to protect the pump against mechanical damage caused by foreign objects.

The pumps are equipped with a venting and a purge gas facility. The connections are blanked off by default with G1/8" closure screws.

Venting and purge gas valves, or a venting screw, or a pressure regulator can be connected directly to the pump.

1.2 Standard equipment

Turbomolecular pump with integrated electronic drive unit, two eye-bolts

High and fore-vacuum flanges are protective-capped.

Flange mounting elements, the DC In plug and the inlet screen are not enclosed, but are available as accessories, see Section 1.5.

Description

1.3 Technical data

TURBOVAC		850 i	950 i
High-vacuum connection	DN	160 ISO-K 160 CF	200 ISO-K 200 CF
Forevacuum connection	DN		25 KF
Pumping speed*	$l \cdot s^{-1}$		
N ₂		720	900
Ar		655	840
He		850	925
H ₂		755	770
Gas throughput*	$mbar \cdot l \cdot s^{-1}$		
N ₂			14
Ar			3.5
He			21
H ₂			> 15
Compression ratio*			
N ₂			> 1·10 ¹¹
Ar			> 1·10 ¹¹
He			1.3·10 ⁸
H ₂			4.4·10 ⁶
Ultimate pressure with 2-stage oil-sealed rotary vane pump ISO-K / CF	mbar	< 3.5·10 ⁻⁹ / < 6·10 ⁻¹⁰	
Max. permissible forevacuum pressure for N ₂	mbar	15	
Operating speed	min ⁻¹	49 200	
Minimum speed	min ⁻¹	30 000	
Run-up time, approx.	min	2.5	
Max. power consumption	W	500 (default), 600 (max.)	
Power consumption at ultimate pressure	W	40	
Type of protection	IP	40	
Ambient temperature during operation	°C	+5 to +40 ¹⁾	
storage		-15 to +70	
Cooling standard		Convection ¹⁾	
Cooling optional		Air or water ¹⁾	
Cooling water connection		plug connection for 6x1 hose / alternatively G 1/8-in. screw-in thread	
Cooling water consumption	l/h	60	
Permissible cooling water pressure (bar(g): bar (gauge) is overpressure, i.e. atmospheric pressure = 0 bar(g))	bar(g)	6	
Permissible cooling water temperature	°C	15 to 35	
Weight ISO-K / CF	kg	14.6 / 19.6	15.4 / 21.7
Recommended forevacuum pumps		TRIVAC, ECODRY, SCROLLVAC	

* Please contact us when using Argon or other "heavy" gases as process gas.

1) * Depending on the ambient temperature, the gas throughput and the type of gas, forced air cooling or water cooling may be necessary.

TURBOVAC		850 i	950 i
Noise level	dB(A)		
with convection cooling			< 50
with radial air cooler			< 52
Max. bake-out temperature of the CF version, at the high-vacuum flange, water cooled	°C		100
Max. rel. air humidity		approx. 85% (non-condensing)	
Purge gas flow	mbar · l · s ⁻¹ sccm		0.4
			24
Purge gas connection			G 1/8"
Venting connection			G 1/8"

1.3.1 Technical data for the integrated drive electronics

Supply voltage	48 V DC +5 % / -10 %
Max. current consumption	11 A (default), 13 A (max.) at 48 V DC
Max. power consumption	500 W (default), 600 W (max.)
Interfaces	see ordering data
Residual ripple	< 3 %
Max. contact rating of the relays	48 V, 0.5 A 24 V, 1.0 A
Overvoltage category	II
Contamination grade	2
Accessory connections	1 pc. M8 connector, 24 V DC
Maximum load rating for the 24 V DC outputs (powering accessories, e.g. cooling unit or valves)	24 V, max. 18 W


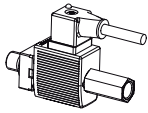

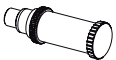
Description

1.4 Ordering data

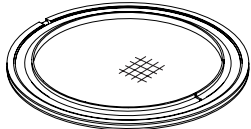
TURBOVAC	850 i	950 i
RS 485, USB+, 15-pin digital I/O interface		
High-vacuum flange	160 ISO-K	200 ISO-K
Part No.	840071V1000	840091V1000
Pump with optional interface	840071V2000	840091V2000
High-vacuum flange	160 CF	200 CF
Part No.	840081V1000	840111V1000
Pump with optional interface	840081V2000	840111V2000

Optional interface (RS 232, Profibus, Ethernet/IP, Profinet, EtherCAT), USB+, 15-pin digital I/O interface: on request

1.5 Accessories

	Part No.	
Power supply	on request	
Cable TURBOVAC supply 48 V DC (HARTING - bare wire ends)		
1 m	800096V0102	
3 m	800096V0302	
5 m	800096V0502	
Accessory cable TURBOVAC i, M8-M8, 2 m	800110V0016	
Y cable TURBOVAC i, M8	800110V0020	
Start stop switch for TMP	800110V0021	
USB cable 2.0 Type A/B, 1.8 m	800110V0108	
Relay box for forevacuum pump, 1-phase, 10A incl. 2 m M8-M8 cable	800110V0030	
LEYASSIST software for TMPs (included in the standard equipment for TURBOVAC iX)	230439V01	
Air cooling TURBOVAC 850/950 i radial	800136V0011	
Water cooling	800135V0007	
Venting valve, 24 V DC, G 1/8"	800120V0012	
Power failure venting valve 24 V DC, G 1/8"	800120V0022	
Purge gas valve, 24 V DC, G 1/8", 24 sccm	800120V0013	
Purge gas throttle 24 sccm	800120V0014	
Air filter for TMP, G 1/8"	800110V0022	
Air drier TURBOVAC	on request	

Description

	Part No.	
Flange heater DN 160 CF, 230V	800137V0007	
Flange heater DN 160 CF, 115V	800137V0008	
Flange heater DN 200 CF, 230V	on request	
Flange heater DN 200 CF, 115V	on request	
Centering ring with coarse inlet screen DN 160 ISO-K (3.2 mm)	800133V0031	
Centering ring with splinter guard DN 160 ISO-K (0.8 mm)	800133V0032	
Centering ring with coarse inlet screen DN 200 ISO-K (3.2 mm)	800133V0041	
Centering ring with splinter guard DN 200 ISO-K (0.8 mm)	800133V0042	
Coarse inlet screen DN 160 CF (3.2 mm)	800132V0031	
Splinter guard DN 160 CF (0.8 mm)	800132V0032	
Coarse inlet screen DN 200 CF (3.2 mm)	on request	
Splinter guard DN 200 CF (0.8 mm)	on request	
Mounting kit TURBOVAC		
DN 160 ISO-K		800134V0030 + 267 01
DN 160 CF		800134V0031
DN 160 ISO-K to ISO-F		800134V0035
DN 200 ISO-K		268044 + 26701 (3x)
DN 200 CF		ES83946 + 83907

Description

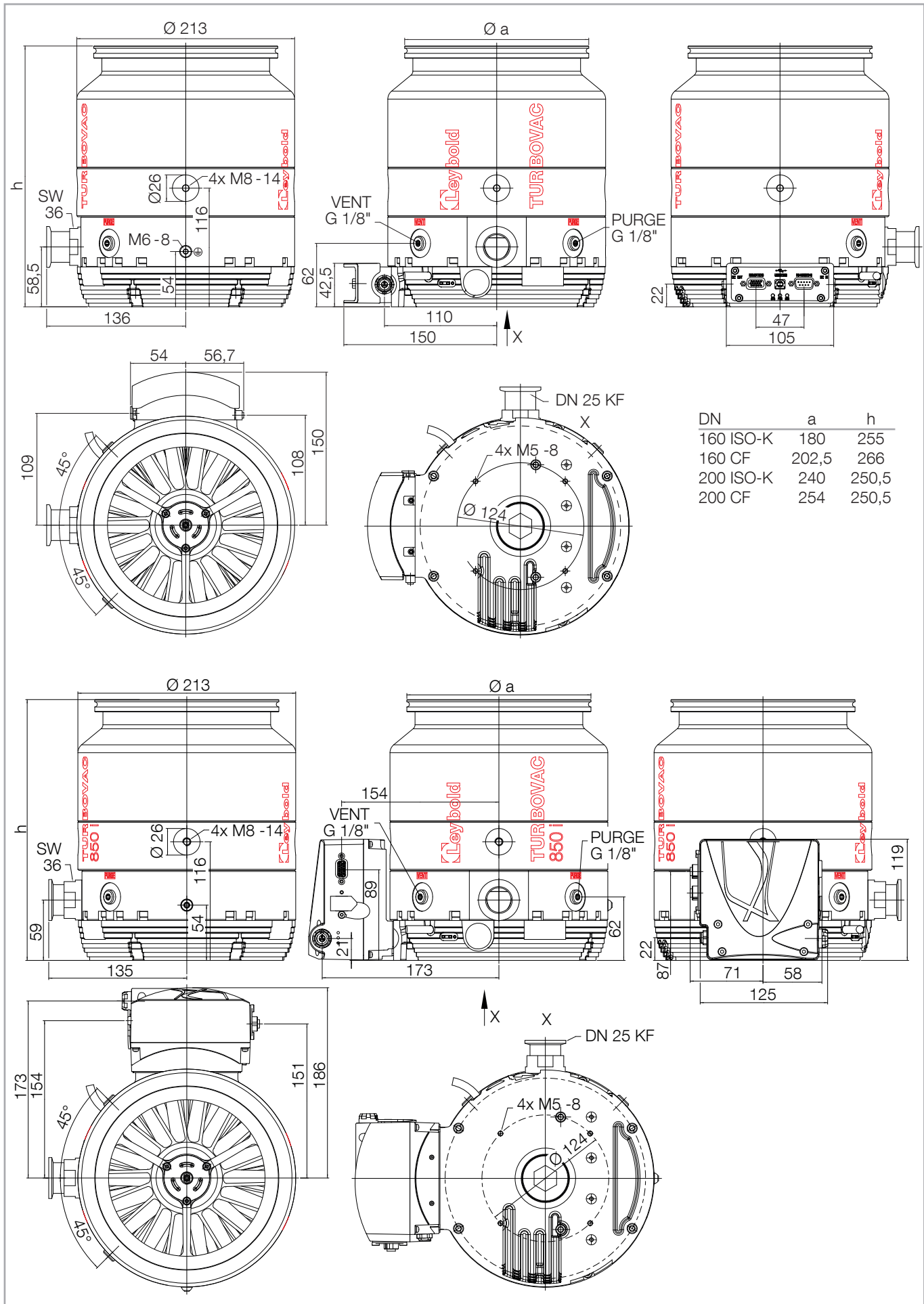


Fig. 1.2 Dimensional drawings, dimensions in mm

2 Transport and storing

Transport

The devices are delivered in safe transport packaging. Check whether the packaging has been damaged during transport. If that is the case, notify the freight forwarder and Leybold if necessary.

Keep transport packaging for any further transportation and storage of the pump. Be careful not to damage the sockets and connections during handling.

Unpacking

The turbomolecular pump is shipped in a sealed PE bag with desiccant. Do not open the PE bag until immediately before installing. Do not remove the covers and blanking flanges until you are ready to make the connections, to ensure that the turbomolecular pump is installed under the cleanest possible conditions.

The pump is equipped with four M8 boreholes for eye-bolts for transport. Remove the pump from the packaging using the two eye-bolts provided, guiding it with one hand.

Transport the pump only in its transport packaging or at the eye-bolts provided for this purpose. Do not stand below the pump while connecting or removing the turbomolecular pump.

CAUTION



Storing

To store the devices, place them in a sealable PE bag containing a drying agent and use the supplied transport packaging. Do not store pump and accessories in a moist atmosphere so as to prevent these items from suffering corrosion. Take note of details in Section 4.8.

For pumps that have been stored for more than 12 months, a ball bearing run-in procedure must be carried out before operation, see Section 4.7.

For pumps that have been stored for more than 3 years, we recommend a preventive exchange of the ball bearings, see Section 5 Bearing replacement.

3 Installation

3.1 Conforming utilization

The turbomolecular pump is intended for generating a vacuum. It is suited for non-corrosive processes only.

The turbomolecular pump must be bolted to a rigid vacuum system and connected to a suitable backing pump.

It is intended for being operated within closed rooms.

The use of any accessories which have not been specified by Leybold is only allowed after approval by Leybold.

3.1.1 Non-conforming utilization

Non-conforming utilizations for both pump and frequency converter are among others:

- Pumping of gases and vapours for which the materials of the pump are unsuitable.
- Operation in connection with processes in which GaAs (gallium arsenide) is being pumped.
- Pumping of gas mixtures with an oxygen content of > 21%.
- Pumping of corrosive gases and dust containing gases without reverting to purge gas operation.
- Pumping of condensable vapours without suitably controlling the temperature of the pump. Upon compression within the pump, these vapours may condense or form deposits.
- Pumping of dusts and solids without the use of suitable screens and filters.
- Operation at an inadmissibly high forevacuum pressure.
- Operation at inadmissibly high gas loads.
- Utilization of both pump and frequency converter in explosion hazard areas.
- Non-compliance of the specified maintenance and servicing intervals
- Operation of the pump and drive electronics in environments which demand protection type IP 40 or higher and where the installation site is over 4000 m above sea level.
- Utilization in systems and pump systems in which the pressure may exceed 1.4 bar abs.
- Operation with an inadequately mounted pump
- Operation without having flanged the pump to the system or without having connected it to a suitable backing pump.
- Operation with additional heat sources involving thermal radiation, thermal conduction via the high vacuum or the forevacuum flange, strong magnetic fields or very hot process gases, for example. In environments with water cooling operation, CF flanges may be baked-out up to 100 °C.

- Use in systems in which impact stress and vibrations or periodically occurring forces affect pump, frequency converter and cables.
- Operation on moving system or system components (locks, for example).
- Operation at vibration absorbers and vacuum components (gate valves, valves) which are not capable of sustaining the specified deceleration torque should the pump rotor seize.
- Stepping on pump, add-on parts, drive electronics, flanges and cables to climb onto the system.
- Fitting of add-on parts to the forevacuum flange which cause an inadmissible high load.
- Removing, covering or obstructing warning notices.
- Standstill or storing of the pump without suitable sealing-off and drying. Storing in a humid atmosphere can cause corrosion.
- Conversions, manipulations and maintenance work by personnel not authorised by Leybold..

Any non-conforming utilisation of pump, frequency converter and accessories can result in severe injury or death and cause damage to components.

WARNING

3.2 Operating environment

Permissible ambient temperature	5 to 40 °C Depending on the ambient temperature, the gas throughput and the type of gas, forced air cooling or water cooling may be necessary. no dripping or spraying water, no explosive gas atmospheres
Installation altitude	up to 4000 m At altitudes over 2000 m heat dissipation by the ambient air is impaired.

3.3 Fitting accessories

Secondary devices are directly energised and activated via the accessory connection X201 (M8 plug); by means of a Y-cable 2 accessories can be connected at the same time.

In this case both devices will be switched parallelly (i.e. de-energised active / in-active). The factory-set accessories's interface features a plug-and-play mode, and is instantly ready for operation with the connected device (energised with pump switched on).

Installation

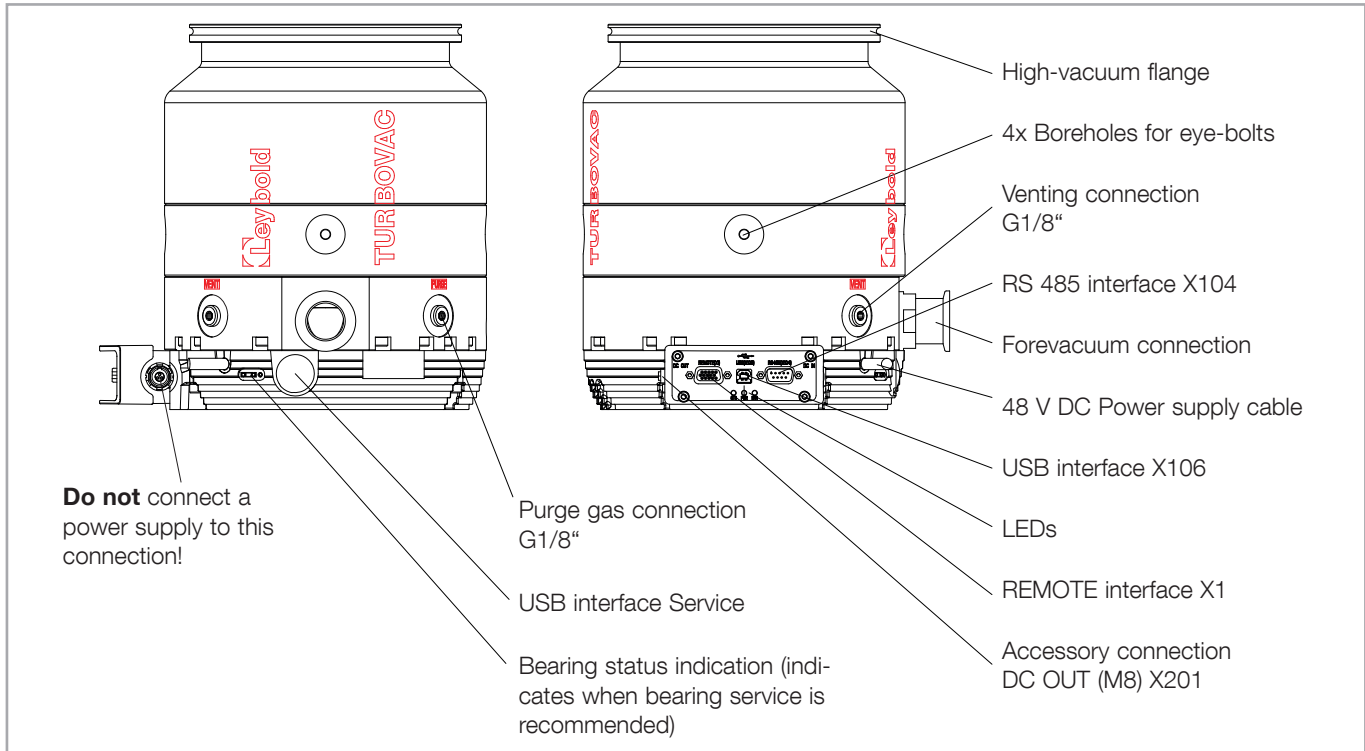


Fig. 3.1 Connections

3.4 Attach the pump to the vacuum chamber

NOTICE



Never touch the rotor. Touching the rotor may cause injury and damage the rotor bearing.

WARNING



If the mounting is not sturdy enough, pump blockage could cause the pump to break loose; internal pump components could be thrown in all directions.

Mount the pump firmly to the vacuum chamber. Never operate the pump without proper flanging to the vacuum chamber (in bench testing, for example).

Do not operate the vacuum pump with open flanges. Do not reach into the pump.

Remove the transport seal from the intake flange and remove the desiccant. Pay attention to maximum cleanliness when connecting.

Torque when the rotor seizes

In the case of a sudden rotor vane rupture or rotor-stator contact which may occur in practice (caused, for example, by solid objects from the process chamber entering the pump through the high vacuum flange), the following torques need to be absorbed by the system:

TURBOVAC 850/950 i

max. 10 kNm

In most applications the pump is flanged to the high vacuum flange at the apparatus. The pump can be mounted and operated in any desired attitude.

When using flange connecting elements in accordance with DIN 28404, ISO 1609 (ISO-K flange connection) or ISO 3669 (CF flange connection), which fit positively to the pump flange, check the maximum load capacity of the connecting element. Not all flange components can withstand the forces that occur in a crash.

If the strength of the component is not sufficient, there is the possibility of providing an additional safeguard via the four threaded holes for the eye-bolts for transport. Ensure that the mountings can withstand the braking torque.

The flange material to which the pump is bolted, must have at operating temperature a minimum strength specification of 150 N/mm².

If several turbomolecular pumps are installed to the vacuum chamber of the same system, there is the risk of interference (vibration interference between the pumps). If such a risk exists please contact Leybold Application Support.

The standard mounting arrangement for the pump is adequate to ensure earthquake protection. If required mount the system to the floor or the walls.

Install a splinter guard or an inlet screen

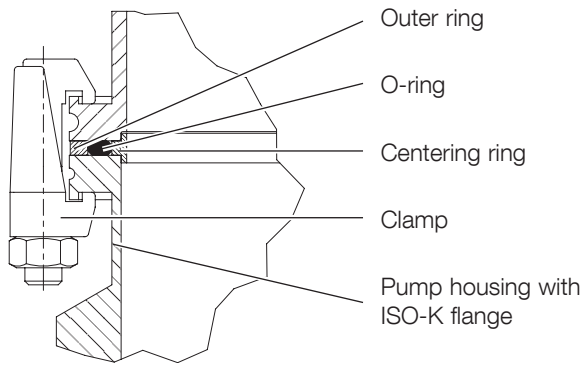
To protect the TMP against foreign material from the vacuum vessel we recommend to mount a centering ring with a fine or coarse inlet screen at the high vacuum flange, though this will reduce the pumping speed at the chamber flange.

Reduction of the pumping speed in %	H ₂	He	N ₂	Ar
Fine inlet screen DN 160/200	6	9	20	23
Coarse inlet screen DN 160/200	1	2	6	7

Damages caused during operation without the inlet screen are excluded from warranty.

Installation

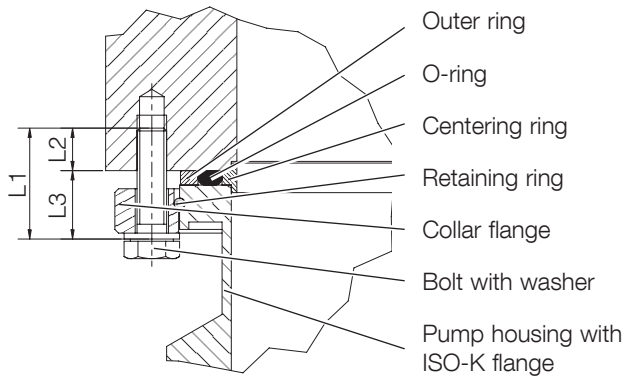
ISO-K flange at ISO-K flange



Flange	DN 160 ISO-K	DN 200 ISO-K
Number of clamps	12 x M10	
Minimum clamp strength, yield strength	> 450 N/mm ²	
Fastening torque	20 ⁺³ ₀ Nm	

The fastening torque levels apply to lubricated threads.

ISO-K flange at ISO-F flange with collar flange



Flange	DN 160 ISO-K	DN 200 ISO-K
Number of bolts	8 x M10	12 x M10
Minimum bolt strength, yield strength	> 600 N/mm ²	
Minimum screw in depth L2 for steel	13 mm	
for aluminium	18 mm	
L3	23 mm	
Recommended bolts – ISO 4014 for steel flanges	M10x40	
for aluminium flanges	M10x45	
Bolt quality stainless steel bolts	8.8 or A2(A4)-80	
Fastening torque	35 ⁺⁵ ₀ Nm	

Fig. 3.2 Mounting high vacuum flange ISO-K

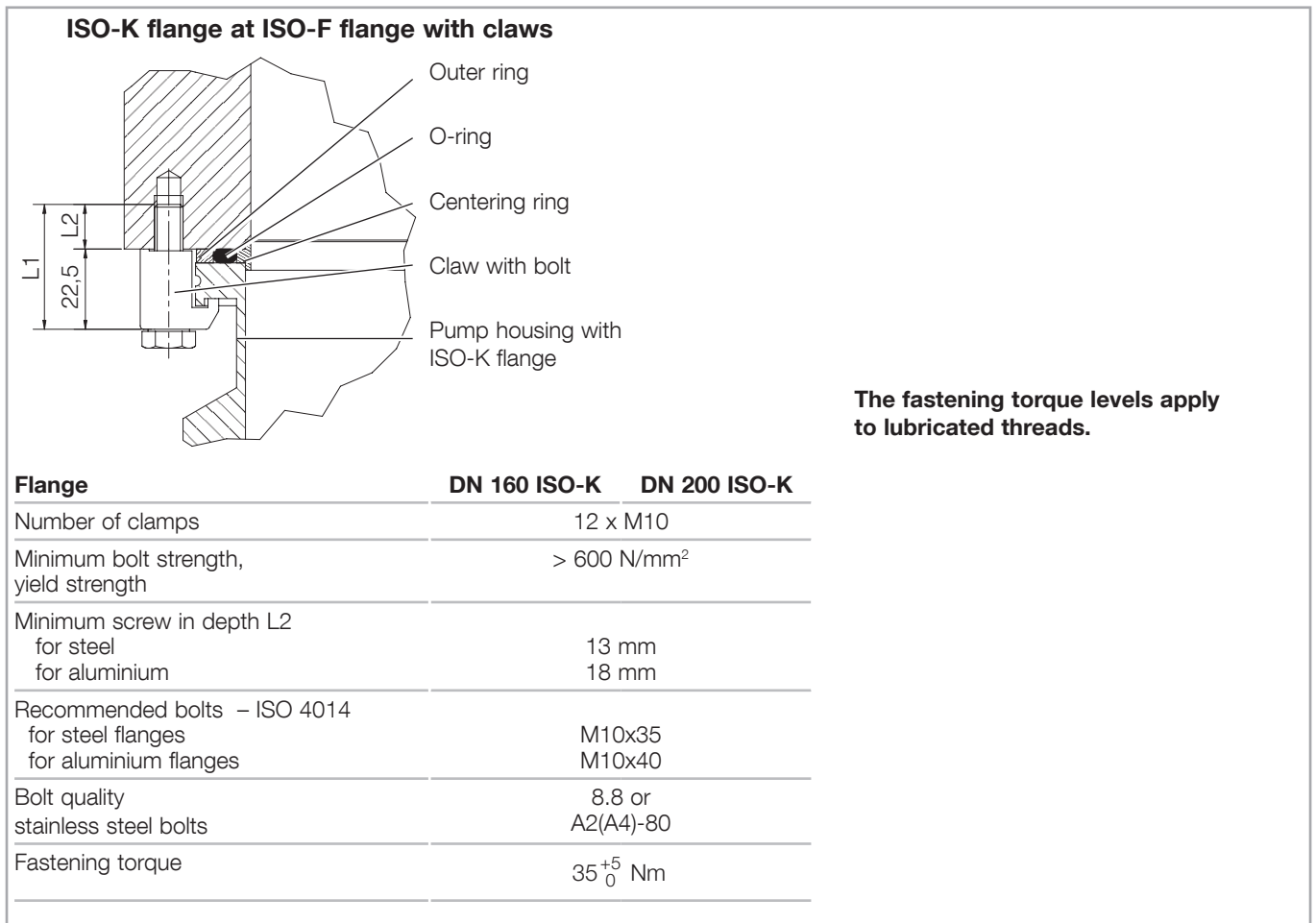


Fig. 3.3 Mounting high vacuum flange ISO-K

Flange mounting for ISO-K flanges

When flanging on the high vacuum connecting flange, place the O-ring on the centering ring. The O-ring must remain in place smooth and untwisted. Thereafter put the outer ring (support ring) in place.

Mount the turbomolecular pump according to Fig. 3.2 and 3.3 and tighten the bolts crosswise step-by-step.

When using an ultra sealing ring, always use an outer support ring. The information on the number of bolts and clamps also applies to the ultra sealing rings.

Required for the installation:

- mounting kit (accessories)
- coarse or fine inlet screens (accessories, optional)

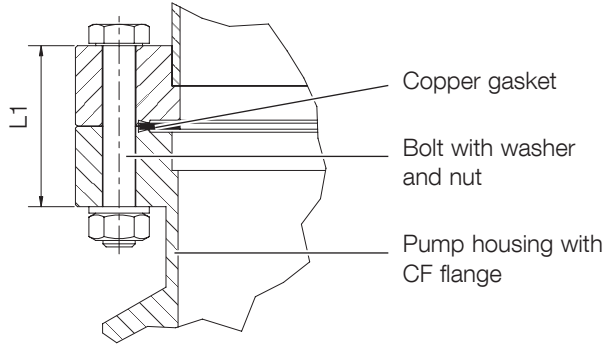
The contact surfaces of pump housing, vacuum system and centering ring must be free of grease and dry so as to ensure adequate strength in case the rotor should seize.

NOTICE



Installation

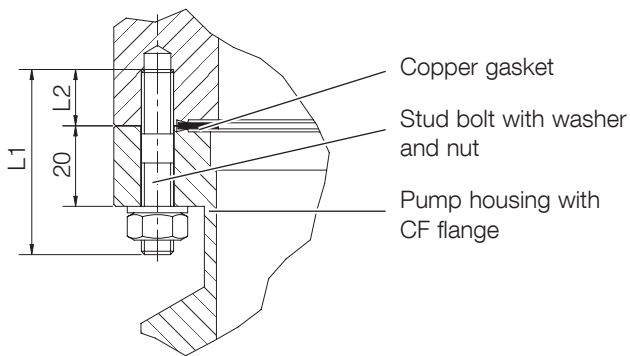
CF flange connection with clearance hole



Flange	DN 160 CF	DN 200 CF
Number of bolts	20 x M8	24 x M8
Minimum bolt strength, yield strength	> 450 N/mm ²	
Recommended bolts – ISO 4014 L1 =	M8x55 44	M8x60 49
Bolt quality stainless steel bolts	8.8 or A2(A4)-70	
Fastening torque	15 ⁺² ₀ Nm	

The fastening torque levels apply to lubricated threads.

CF flange connection with blind hole thread



Flange	DN 160 CF	DN 200 CF
Number of bolts	20 x M8	24 x M8
Minimum bolt strength, yield strength	> 450 N/mm ²	
Minimum screw-in depth for steel	12 mm	
Recommended bolts for steel flanges – DIN 835 L1 =	M8x30 46	M8x30 51
Bolt quality stainless steel bolts	8.8 or A2(A4)-70	
Fastening torque	15 ⁺² ₀ Nm	

Fig. 3.4 Mounting the CF high vacuum flange

Flange mounting for CF flanges

Before fitting, check to ensure that the sealing edge is undamaged. Do not touch the copper gasket and the sealing edge with your bare hands.

The contact surfaces of pump housing, vacuum system and centering ring must be free of grease and dry so as to ensure adequate strength in case the rotor should seize.

Mount the turbomolecular pump according to Fig 3.4 and tighten the bolts step-by-step.

When the pump shall be baked out, the threads of the bolts should have been lubricated with a high temperature lubricant.

Required for the installation:

- mounting kit (accessories)
- coarse or fine inlet screens (accessories, optional)

During operation the pump can get so hot that there is the risk of suffering burns (up to approximately 65 °C). Protect the hot parts against being touched.

3.5 Forevacuum connection

Connect the clean forevacuum line with the small flange connectors and take care not to constrict the forevacuum flange's diameter.

Ensure that the pump is sufficiently isolated against vibrations generated by the forevacuum pump.

No forces from the piping system may be allowed to affect the turbomolecular pump. Support the piping correspondingly or decouple through flexible joints.

Do not use the pump with a backing pressure below 5×10^{-4} mbar. Lower backing pressures will increase the evaporation rate of the lubrication reducing the bearing life.

The forevacuum line must be tight. Hazardous gases can escape at leaks or the gases being pumped can react with air or humidity. Observe Safety Information 0.4.

The forevacuum pump can be energised at the accessories connection of the TURBOVAC i via the relay box.

NOTICE



CAUTION



NOTICE



WARNING



Installation

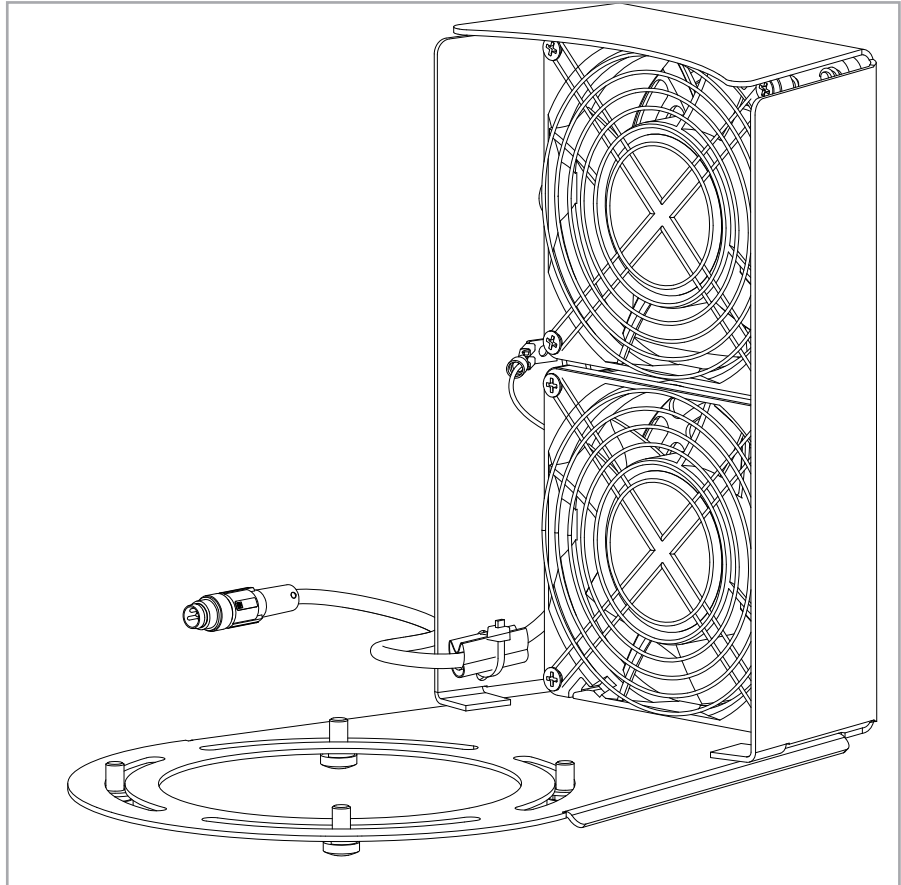


Fig. 3.5 Air cooling

3.6 Connect the cooling

Cooling of the pump depends on the required pumping power and the ambient temperature. When the pump is insufficiently cooled it will shut down.

High gas throughputs, cyclic operation or high ambient temperatures will necessitate air or water cooling.

3.6.1 Air cooling

When installing air cooled pumps within a system ensure that sufficient quantities of fresh air are freely available. The air cooling facility is powered via the pump.

Use the 4 bolts which are included in the delivery to attach the air cooling unit at the bores provided on TURBOVAC. Plug in the control cable of the air cooler into the accessories connection and screw tightly. The accessory connection is so pre-configured that the air cooler will always be running when the pump is running. To change this setting, refer to the interface Operating Instructions.

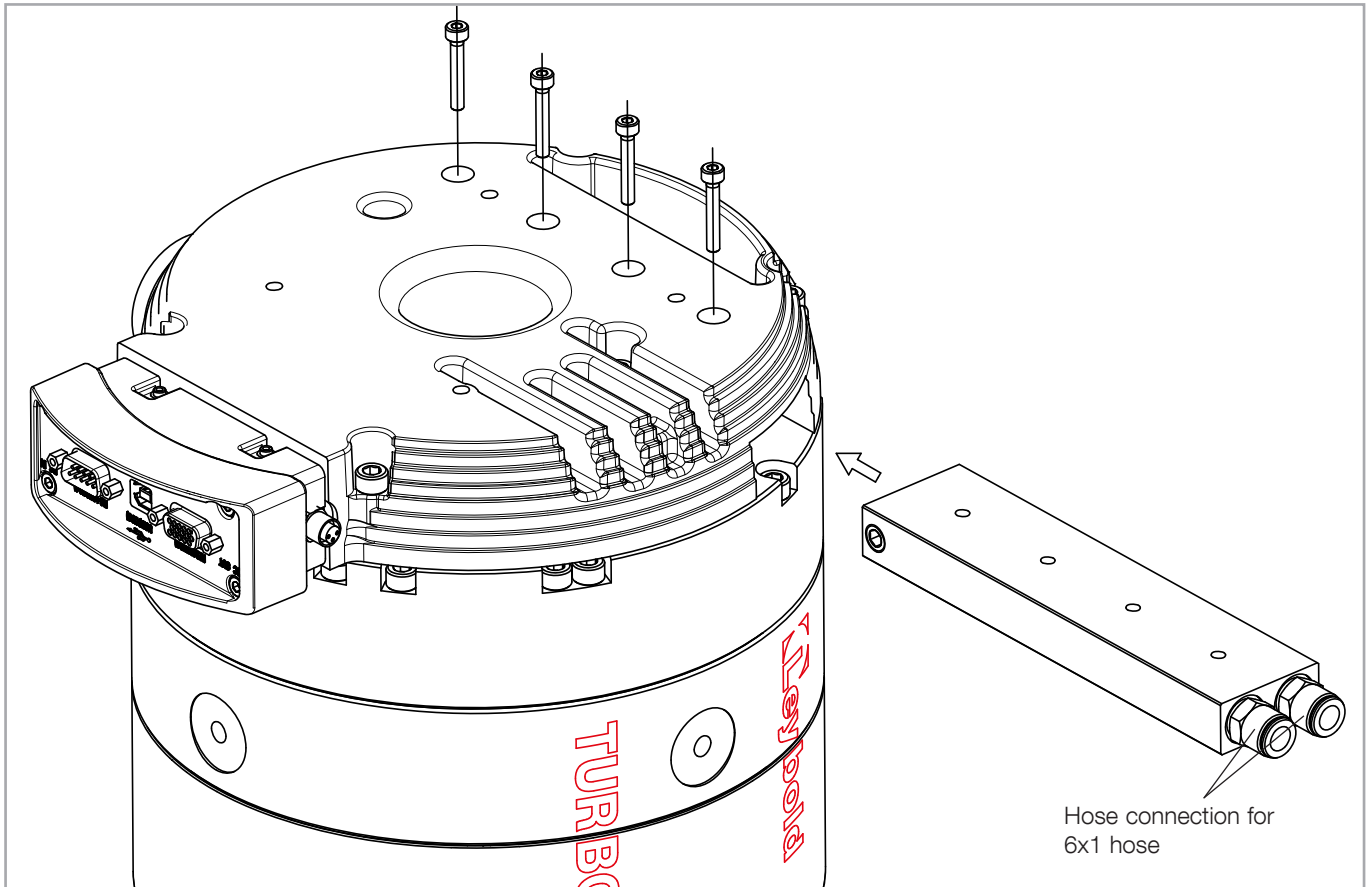


Fig. 3.6 Attaching the water cooling

3.6.2 Water cooling

Attach the cooling water block to the TURBOVAC with 4 M4 screws, tightening torque is 3^{+1} Nm. Connect the cooling water hoses.

The hose connections may be unscrewed and removed, to make use of the integrated G 1/8"-threads.

Adjust the cooling water temperature so that the formation of condensate is avoided. With pump downtimes the cooling water has to be turned off.

When switching the cooling water supply on and off by means of an electrically actuated valve, connect the valve so that it will be switched on and off together with the pump.

Installation

3.6.3 Water Quality

In order to ensure long trouble-free operation the cooling water must not contain any oils, greases and suspended solids. Moreover, we recommend compliance with the following limit values:

Appearance	Clear, free of oils and greases
Suspended matter	< 250 mg/l
Particle size	< 150 µm
Electrical conductivity	< 700 µS/cm
pH value	7.0 to 9.0
Total hardness (total alkaline earths)	< 8 °dH
Aggressive carbon dioxide	None, not detectable
Chloride	< 100 mg/l
Sulphates	< 150 mg/l
Nitrate	≤ 50 mg/l
Iron	< 0.2 mg/l
Manganese	< 0.1 mg/l
Ammonium	< 1.0 mg/l
Free chlorine	< 0.2 mg/l

8 °dH (degrees German hardness) = 1.4mmol/l
= 10 °e (degrees English hardness)
= 14 °f (degrees French hardness)

If there is the danger of frost, you may use a water glycol mixture of up to 30 %.

DS water (softened or fully desalinated water) can be used for cooling the pump, if the pH value corresponds to the range indicated above.

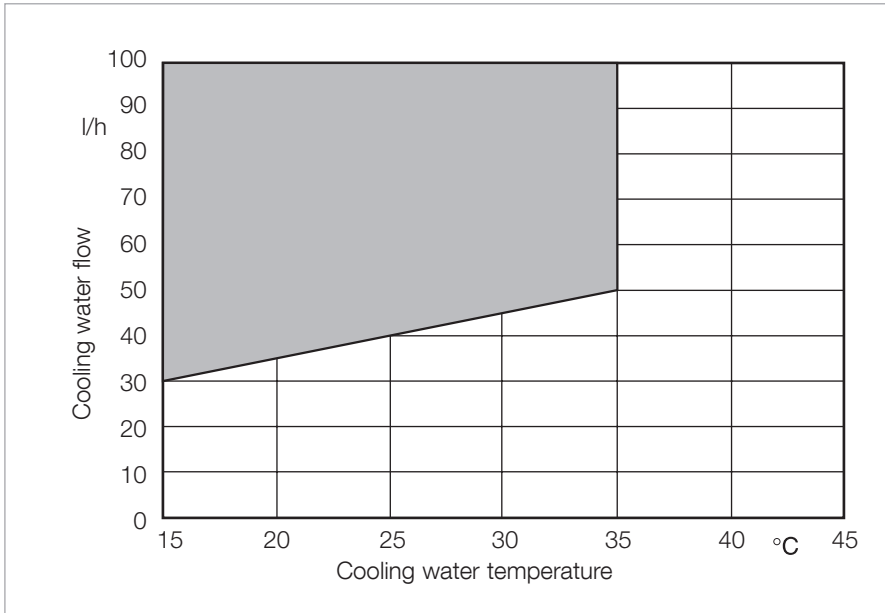


Fig. 3.7 Cooling water requirements

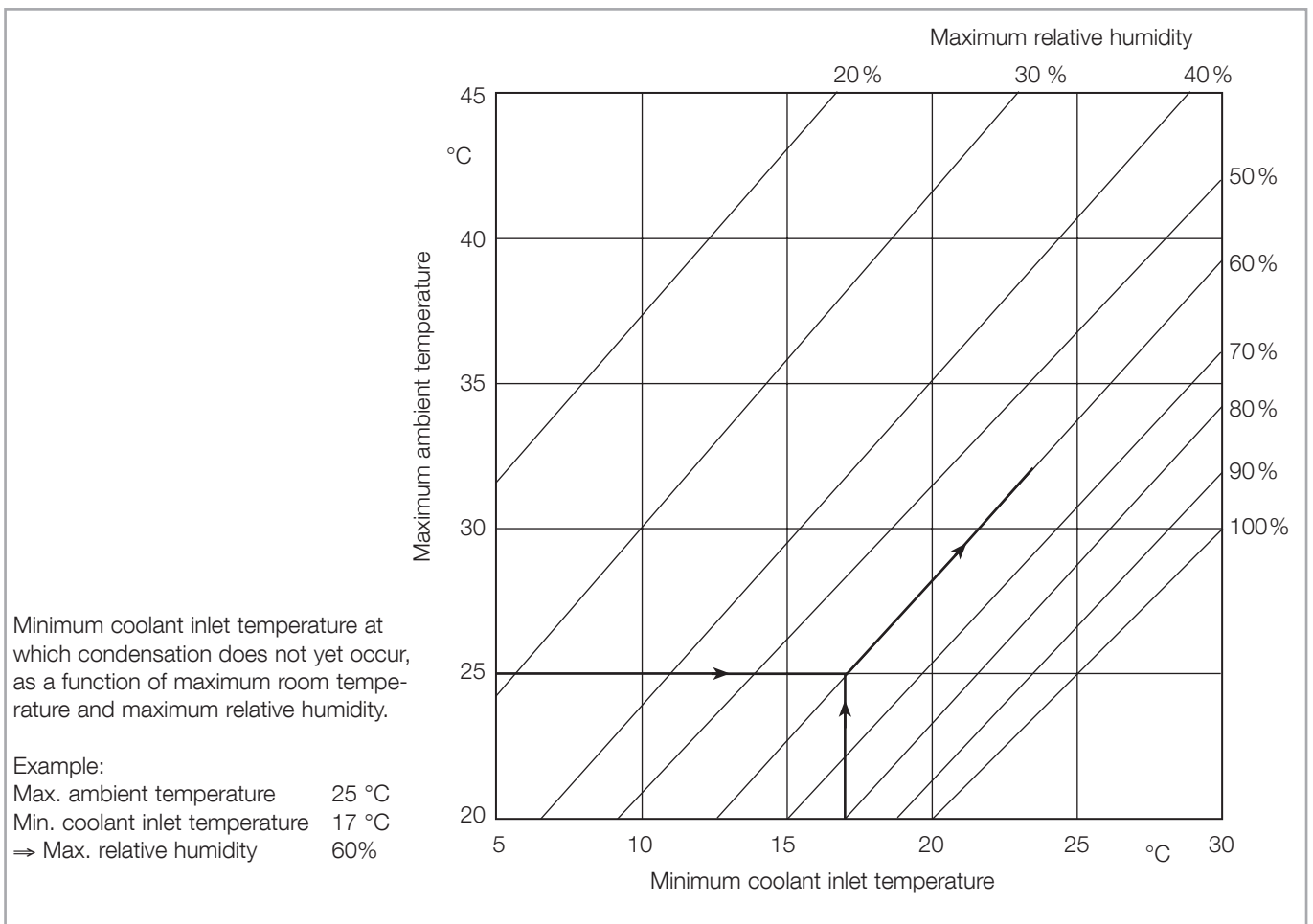


Abb. 3.8 Dewpoint diagram

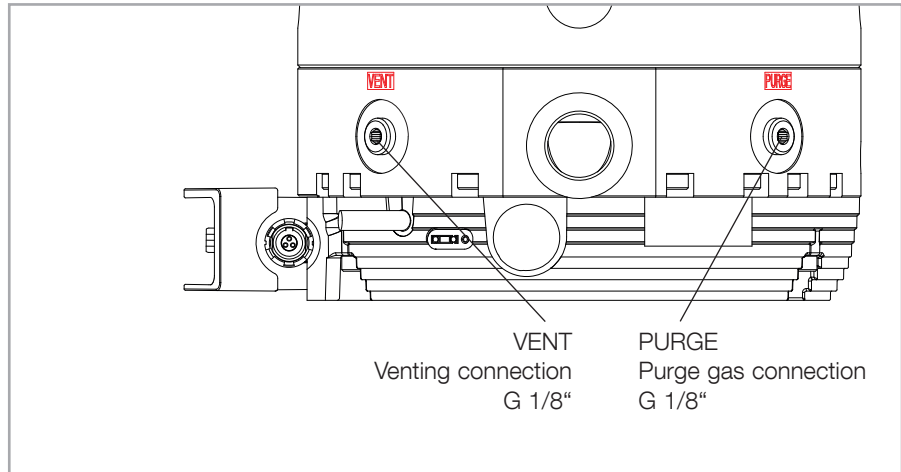


Fig. 3.7 Venting and purge gas connections

3.7 Connect a power failure venting valve or a venting valve

The power failure venting valve (normally open) or venting valve (normally closed) vents the pump and the forevacuum line when the pump is switched off and thus keeps oil vapor from diffusing back from the forevacuum line. A choke nozzle in the vent port ensures that the pump is not vented too fast.

The max. permissible pressure in the pump must not exceed 1.4 bar (abs.).

Unscrew and remove the locking screw and the gasket from the venting connection of the TURBOVAC.

Screw in the venting valve and the gasket into the venting connection. To protect the threads, the max. fastening torque is 5 Nm.

If applicable connect the venting gas supply at the valve's inlet (G1/8").

CAUTION



When using the pump with purge gas, protect the purge gas supply such that in the event of a malfunction no overpressure can occur within the system. The pressure in the pump must not exceed 1400 mbar (0.4 bar overpressure).

NOTICE



Connect a purge gas or venting valve to the correct flange. Confusing the venting and purge gas flange can cause shock venting of the pump.

Plug in the corresponding control cable into the accessories connection.

For the electronic drive unit change the venting valve settings to venting operation (via the interfaces).

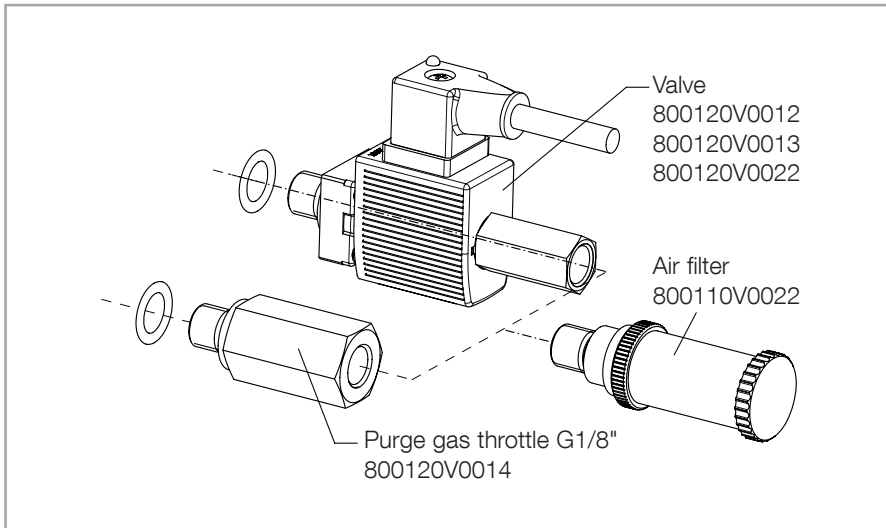


Fig. 3.8 Fitting valve

3.8 Connect purge gas

When having to decide which gases need or not need to be pumped with purge gas we are available to provide assistance.

Refer to Section 4.1 for suited gases.

Consider the additional purge gas flow when selecting a suitable backing pump.

We recommend a purge gas flow of 0.4 mbar·l/s (24 sccm) with Nitrogen.

The pressure in the pump must not exceed 1400 mbar (0.4 bar over-pressure).

The purge gas is fed either through an activated valve or a manually operated throttle.

Purge gas connection with purge gas valve

Unscrew and remove the locking screw and the gasket from the purge gas connection of the TURBOVAC.

Screw in the purge gas valve and the gasket into the thread.

Connect the purge gas supply at the valve's inlet (G1/8").

Either connect the purge gas valve electrically separately or connect it to an accessory connection and thereafter change the function for the accessory connection. For this refer to the interface Operating Instructions.

Purge gas connection with purge gas throttle

Unscrew and remove the locking screw and the gasket from the purge gas connection of the pump.

Then screw in the throttle and the gasket into the thread.

CAUTION



3.9 Connect a flange heater

Only for TURBOVACs with CF flange

If pressures in the range of 10^{-8} mbar or below are to be developed, the vacuum chamber and the components installed therein will have to be baked out. In addition, the TURBOVAC can be baked out using the flange heater provided for this purpose.

With the aid of the relay box the heating jacket can be driven directly via the turbopump. For this connect the heating jacket to the relay box and insert the connection cable of the relay box at the accessory connection and screw it down.

The accessory connection has been so pre-configured that the heating jacket will heat as long as the turbomolecular pump is running. To change this setting, refer to the interface Operating Instructions.

Alternatively the heating jacket may be connected through the corresponding mains power cable to the power supply.

Information on baking out is also given in Section 4.6.

3.10 Electrical connection

CAUTION



Observe Safety Information 0.2

Unplug any connectors only when the mains voltage is switched off **and** the pump does no longer turn.

The frequency converter is not equipped with its own emergency shut down switch. This may lead to an unwanted pump start-up.

Install an emergency shut down switch in the system. The emergency shut down switch must be

- present in the building installation
- suitably arranged and easily accessible for the user
- marked as the disconnecting device for this device.

The pump can be operated with 48 V DC power supply. Take note of the performance data specified in Section 1.3.1.

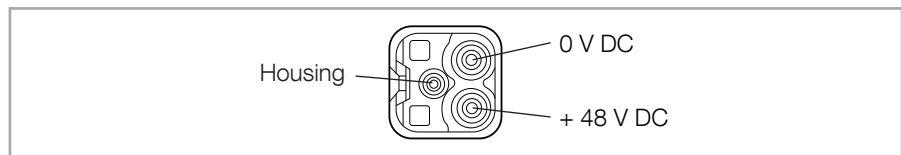


Fig. 3.11 Power supply connector

The cable protection and voltage drop and the minimum supply voltage must be adhered to when wiring.

When operating more than one pump with a single power supply, it may be necessary to fuse each pump separately due to the line protection.

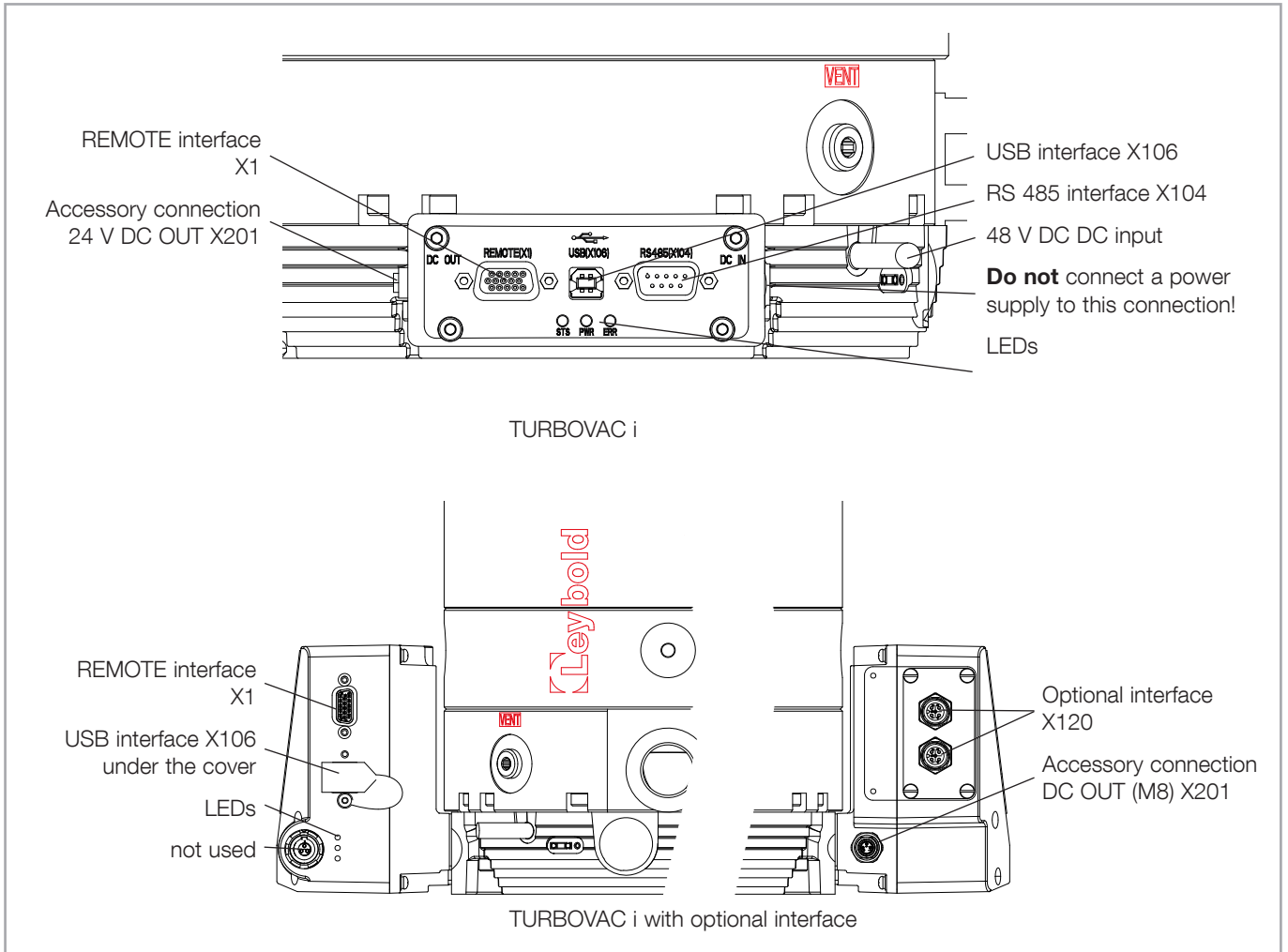
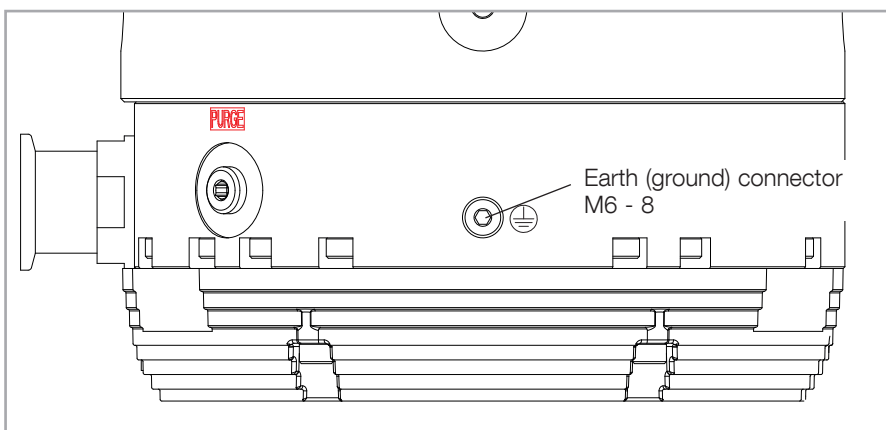


Fig. 3.12 Interfaces

Earth (ground) connection

We recommend fitting a separate earth (ground) conductor. The impedance between the pump body and the earth connection point must be $< 0.1 \Omega$.



Installation




 STS  PWR  ERR	green LED STATUS	
	off:	Pump at standstill (< 3 Hz)
	flashes slowly 1/s:	Start command is present (about 10 s after start)
	flashes fast 3/s:	Running up
	flashes slowly 0.5/s:	Running down
	on:	Normal operation
	yellow LED POWER	
	off:	No supply voltage
	flashes 1/s:	Supply voltage too low or too high
	flashes 3/s:	Running down and pump speed < 100 Hz
	on:	Supply voltage is present
	red LED ERROR	
off:	No error, no warning	
flashes:	Warning is present, pump can be operated possibly with some restrictions or run-in procedure is running	
on:	Fault is present, pump stopped or can not be operated	
LED running light (green-yellow-red)		
Pump is in a state in which it cannot be controlled		
Possible reasons:		
<ul style="list-style-type: none">■ Initialisation shortly after switching on the supply voltage■ Memory procedure in progress (power supply must not be interrupted)■ Reset of factory setting is ongoing■ Firmware update is ongoing		
Valid from firmware parameter P2: R02.09.01		

Fig. 3.13 LEDs

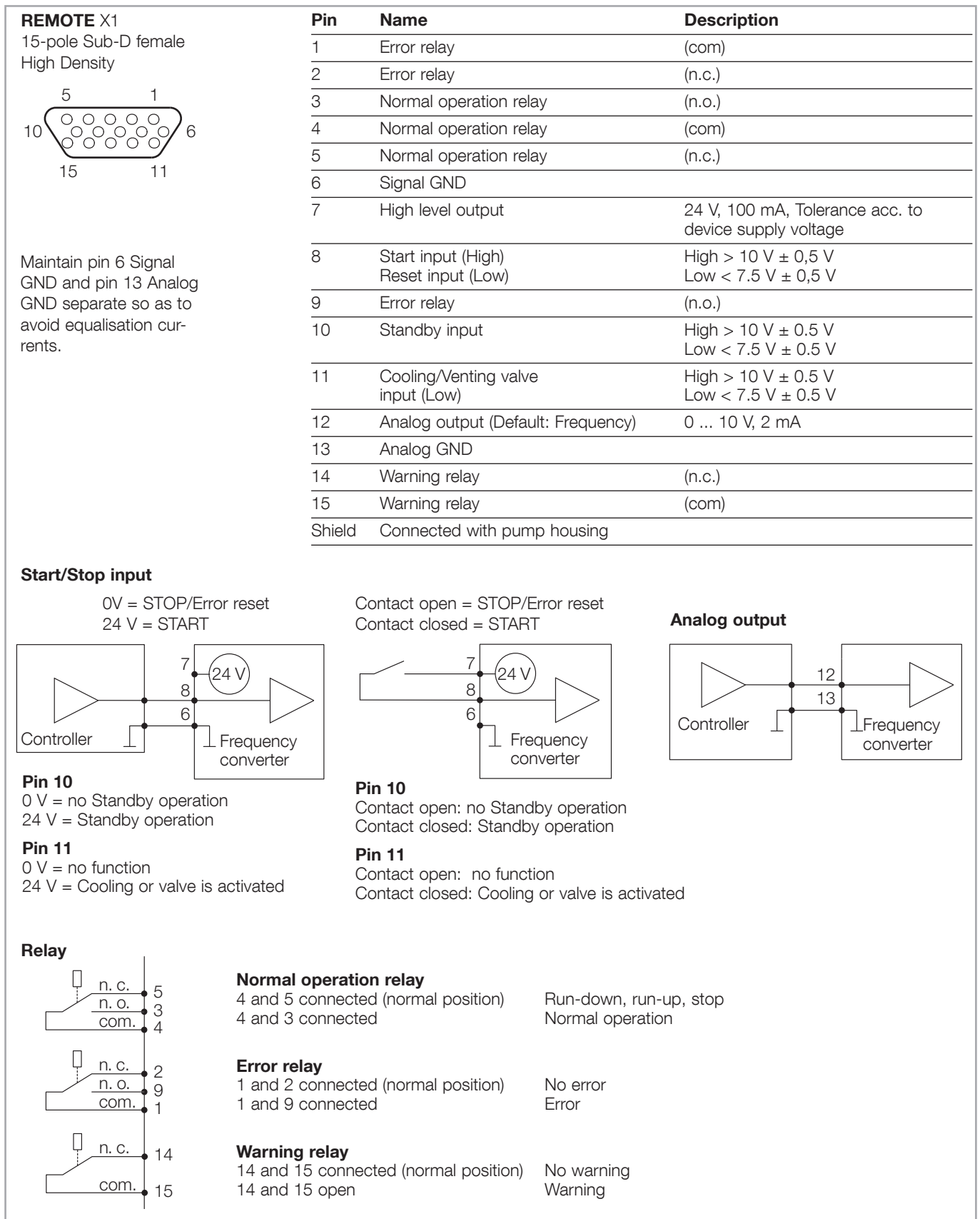


Fig. 3.14 REMOTE interface X1

Installation

Relay status

Input data / status				Output data				Operating mode	
Start/stop signal	Pump rotating	Normal frequency $\geq 90\%$ of setpoint frequency	Error is present	Motor drive	Relay NORMAL OPERATION	Relay ERROR	LED STATUS (green)	LED ERROR (red)	Other modes are not possible; they indicate a failure affecting the frequency converter.
Stop	no	no	no	off	passive	passive	off	off	Pump not operating
Stop	yes	no	no	off	passive	passive	flashes	off	Pump is decelerating
Stop	yes	yes	no	off	passive	passive	flashes	off	Just after stop; pump was in the normal operating mode before that
Start	no	no	no	on	passive	passive	off	off	Just after start
Start	yes	no	no	on	passive	passive	flashes	off	Pump is accelerating
Start	yes	yes	no	on	active	passive	green	off	Pump is in the normal operating mode
Stop	no	no	yes	off	passive	active	off	red	Error is present; pump is at standstill
Stop	yes	no	yes	off	passive	active	flashes	red	Error is present; pump is decelerating
Stop	yes	yes	yes	off	passive	active	flashes	red	Error has just occurred
Start	no	no	yes	off	passive	active	off	red	Error is present; pump is at standstill
Start	yes	no	yes	off	passive	active	flashes	red	Error is present; pump is decelerating
Start	yes	yes	yes	off	passive	active	flashes	red	Error has just occurred

4 Operation

4.1 Media compatibility / purge gas

The TURBOVAC integra is suitable for pumping air and clean gases.

If reactive gases in low concentrations must be pumped operate the pump with purge gas.

We would be glad to consult with you as regards the media which can safely be handled with this unit.

Install a micropore filter when pumping media which contains dust.

Suited for venting or purging are all gases,

- which will not cause corrosion or pitting in aluminium and steel and
- which in connection with process deposits in the pump will not cause corrosion or sticking.

For venting and as the purge gas we recommend inert gases like nitrogen or argon. The temperature of these gases should be between 5 °C and 80 °C, max. relative humidity should not exceed 10 ppm.

The gas must be clean.

In individual cases and after consultation also dry, filtered, oil-free air or filtered ambient air may be used (filter mesh < 1µm).

Change the filters after some time, at least annually.

4.2 Interfaces

The TURBOVAC i(X) is always equipped with the following interfaces for customers:

- USB (COM port) (X106)
- REMOTE (X1)

Moreover, some models are equipped with an Anybus interface which in turn may be equipped with different interfaces like a RS 485, for example.

The control hierarchy is as follows: Anybus interface → USB → REMOTE (X1). See also parameter 179.

The frequency converter is configured through the parameters according to the parameter list. Pxxx denotes parameter value xxx.

The PC software LeyAssist allows convenient access by the user to the parameters of the frequency converter.

Operating Instructions 300450826 Serial Interfaces for TURBOVAC i/IX offer a detailed description of the interfaces RS 232, RS 485, Profibus and USB of the TURBOVAC.

Operation

Applications which can be implemented with the aid of the serial interface:

Application	Benefits to the customer	How to do it
Networking of several pumps and other equipment	Savings relating to the costs for signalling cables	With Field Bus systems
Automation	Savings related to repetitive manual work	For example by a control computer
Avoidance of warnings and warnings before overload operation and early detection of a failing pump	<ul style="list-style-type: none"> ■ Precise planning for maintenance ■ Improved reliability of sensitive production processes in a vacuum 	Monitoring of: <ul style="list-style-type: none"> ■ Motor current P5 ■ Motor temperature P7 ■ Frequency converter temperature P11
Standby operation	<ul style="list-style-type: none"> ■ Cutting process gas consumption ■ Cutting energy consumption 	Reducing the rotor's frequency through P24
Troubleshooting	Quick analysis of problems	Reading of error memories P171, P174 and P176: error code, speed, operating hours for error Read out warning messages through P227
Slow pressure control by changing the pumping speed	Dispensing with a flow controller	Changing the rotor frequency through parameter 24
Starting the pump with a delay if several consumers are connected to the same PSU	Cost savings through smaller power supply units if peak loads can be reduced	With P36, delay
Lowering the normal operation threshold	Normal operating mode is attained faster, processes can be started faster	Reduce frequency threshold through P25
Control cooling water flow	Avoid condensation during cooling water operation	Connect cooling water valve at accessory connection (X201, for example)
Enable generator operation (power backup mode)	The power produced by the pump when running in the generator mode may be used for other electrical consumers and the pump is also decelerated faster.	With P249 This function is only changed after de-energising the pump and then restarting it.

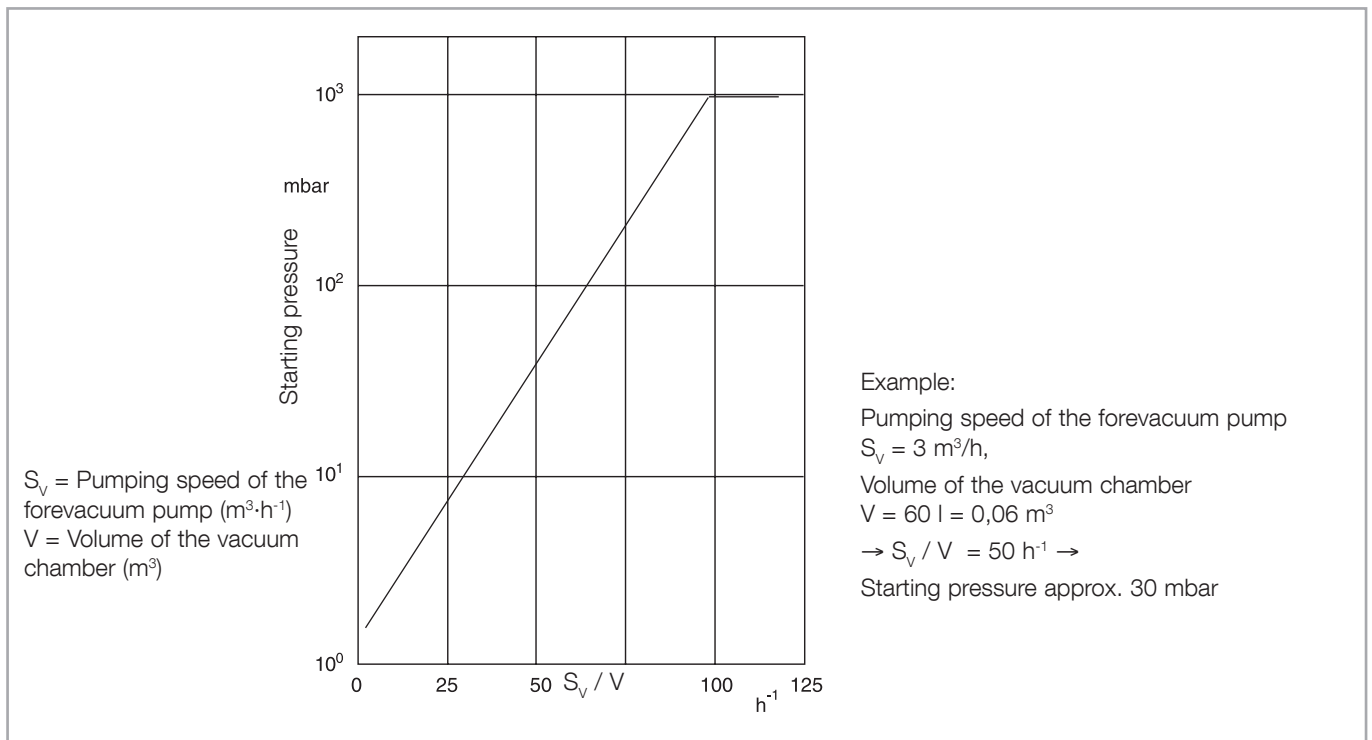


Fig. 4.1 Determining the starting pressure of a turbomolecular pump when evacuating large volumes

4.3 Switching on

For pumps that have been stored for more than 12 months, please take note of Section 4.7.

Switch on the power supply. All LEDs come on one after the other (sequential light), drive electronics (and vacuum system controller) are running up (for approximately 35 seconds).

The maximum starting pressure for the turbomolecular pump can be read from the graph in Fig. 4.1.

Switch on the turbomolecular pump

- via pins 7 and 8 of the socket REMOTE (X1) (For example via a remote control or with the aid of the plug with integrated ON/OFF switch.
- by a start command via the interface.

The turbomolecular pump accelerates. The green LED flashes. When the pump reaches normal operation the green LED lights up permanently.

Avoid the influences of shock and vibration when the pump is running.

Exposure of the pump to accelerating forces must be avoided or reduced to such an extent that the rotor unit will not be excited by vibrations. In the case of critical applications you must consult our Applications Dept. first.

After a mains power failure the pump can run up automatically once more if a start command is present.

Starting pressure

NOTICE



4.4 Shutting down

Switch off the pump.

- via contacts 7 and 8 of the socket REMOTE (X1)
- apply a stop command via the interface
- for the power supply units offered or recommended by Leybold switch off the DC voltage.

Generator operation

After switching off, the green status LED will flash until the rotor of the turbomolecular pump is at standstill. This may take several minutes. With the DC power supply off, the turbomolecular pump will act as a generator supplying the frequency converter and the control unit with the connected devices with energy as indicated by the yellow power LED. When the generator mode is enabled, the turbomolecular pump supplies power back in to the DC power grid.

Switch off the forevacuum pump.

Venting

When using oil-sealed forevacuum pumps, vent the turbomolecular pump before it comes to a stop; refer to Section 4.5.

When using TRIVAC pumps the built-in anti-suckback valve will close automatically, shutting off the forevacuum line. In forevacuum pumps without a vacuum retention valve, close the valve in the forevacuum line.

When the system is not operating, ensure that neither ambient air nor cleaning media can enter the pump.

If a failure occurs the turbomolecular pump will be shut down automatically. The red LED at the frequency converter lights up.

Under vacuum conditions the pump may take up to one hour to run down, when venting to atmospheric pressure it may take up to one minute. During the time the pump is running down, the green LED will flash, indicating that the rotor has not yet arrived at standstill.

When shutting down by **switching off the power supply voltage**, there will be only enough power for the LEDs down to a speed of the pump of approximately 200 Hz. Thus the pump may still turn without a LED being on. For this reason, when switching off without venting, wait for approximately 15 minutes after the LEDs have turned off until the pump has arrived at standstill.

CAUTION



Unplug any connectors only when the mains voltage is switched off **and** the pump does no longer turn.

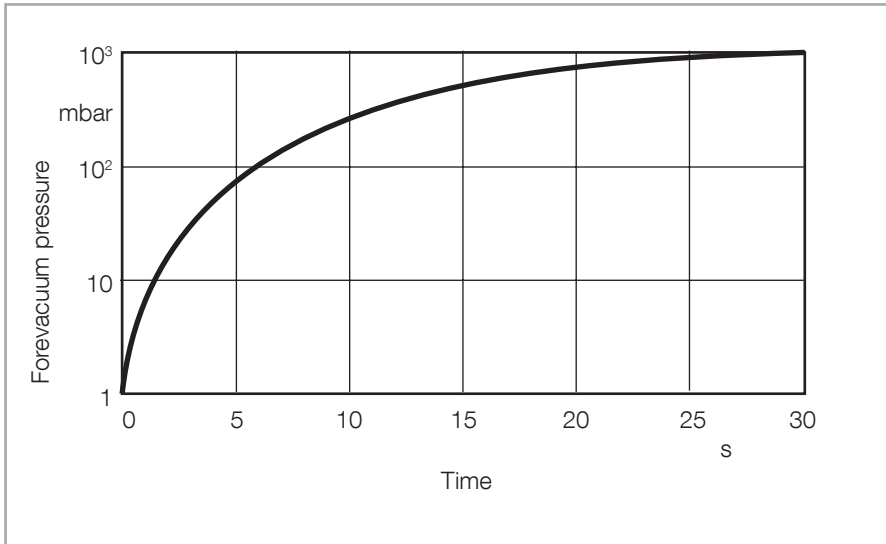


Fig. 4.2 Maximum rise in pressure

4.5 Venting

Refer to Section 4.1 for suited gases.

Venting Methods

There are three different methods of venting the turbomolecular pump.

The pump can be vented via the **venting connection (VENT)**, by means of a venting valve, a power failure venting valve, or a venting screw.

Cautious venting of the pump is possible from the **high vacuum side**, since here the bearing forces will be lowest. When doing so, no free jet of gas must be allowed to form on the rotor so as to avoid exposing the rotor to additional forces.

When venting the pump through its **foreline connection**, neither oil nor particles may be entrained in the gas flow from the forevacuum side into the pump.

Speed of the Pressure Rise

All turbomolecular pumps may be vented at full speed. However, the pressure must not increase faster than specified through the pressure rise curve, see Fig. 4.2..

The pump must be vented significantly slower when there is the risk of particles entering into the pump from the process. During venting, the flow must be of the laminar type in both the vacuum chamber and the turbomolecular pump.

The pump must not be vented to pressures above atmospheric pressure.

Speed

Pressure rise curve

Particles

4.6 Bakeout

Only for TURBOVACs with CF flange, see also Section 3.9.

If pressures in the range of 10^{-8} mbar or below are to be developed, the vacuum chamber and the components installed therein will have to be baked out. In addition, the TURBOVAC can be baked out using the flange heater provided for this purpose.

Protect the rotor against intensive, direct heat radiation. When baking out at the forevacuum side – at a sorption trap, for example – ensure that the components attached direct are not heated to more than 100 °C (212 °F).

Operate the pump with water cooling when baking out.

4.7 Operation after a longer storage period

NOTICE



For pumps that have been **stored for more than 12 months**, a ball bearing run-in procedure for smooth ball bearing running must be carried out when putting into operation again. The procedure differs according to the firmware version of the pump, see the following sections.

To do this, set parameter P119 [0] to the value 1 using a serial interface and save the parameter change with parameter P8. Then start the pump.

This process takes approx. 4.3 hours, the red LED will flash during this time. The TURBOVAC may be operated only with low gas throughput during this time.

At the end, the pump accelerates to the nominal speed and parameter P 119 [0] is written to 0 by the electronics.

For pumps that have been **stored for more than 3 years**, we recommend a preventive exchange of the ball bearings, see Section 5 Bearing replacement.

4.8 Removing the pump from the system

Shut down the pump and vent as described in Sections 4.4 and 4.5.

If the pump has previously handled hazardous gases, implement the proper precautionary measures before opening the intake or exhaust connection.

Observe Safety Information 0.4.6.

Disconnect the pump only when it has come to a full stop. The green LED must have gone out.

During run down the pump may still turn without a LED being on, observe the information on emergency shut down given in Section 4.4.

Then switch the mains power off and wait until the yellow power LED is off. Then only disconnect any cable connections.

The pumps may be contaminated with process gases. These gases may be toxic and hazardous to health. In addition, deposits with similarly dangerous properties may have formed. Many of these gases and deposits form acids when they come into contact with humid air. This will result in serious corrosion damage to the pump.

To avoid health hazards and corrosion damage when the pumps are detached from the system, fasten a container of desiccant under the transport cover of the high vacuum connection and then close the pump immediately at all flange connections. Store the pump, with a desiccant, in an airtight PE bag.

Corrosion damage due to faulty packing will nullify the guarantee.

Pack the pump so that it cannot be damaged during shipping and storage. Pay particular attention to protection for the flanges and the electrical plug.

Observe the instructions in Section 5.2 if you forward the pump to Leybold.

WARNING



Hazardous gases Deposits

Desiccant

Maintenance

5 Maintenance

We recommend an exchange of the rotor unit after 80,000 operating hours at the latest.

Such maintenance work can only be done by the Leybold Service. If required contact the Leybold service center nearest to your location. You can find the address on our internet page www.leybold.com.

At high pump loads - for example during cyclic operation, at high gas throughputs or at high ambient temperatures - the aforementioned maintenance work should be carried forward. Please consult Leybold for recommendations.

Bearing replacement

The ceramic ball bearings at the fore-vacuum side can be exchanged, if necessary, by our customer service, the nearest Leybold Service Center or by the customer: please contact us for this.

If you wish to exchange the bearings yourself, you will need a Leybold tool kit and spare ball bearings. Immediately after exchanging the bearings, let them run in, see Section 4.7.

Purge gas filter

Depending on the degree of contamination of the purge gas used the filter will clog and will have to be exchanged (our experience indicates that this will become necessary after 1 to 6 months).

Adsorption trap

When an adsorption trap is used, regenerate or renew the adsorption agent regularly; refer to the operating instructions provided with the trap.

5.1 Cleaning

If required clean the turbomolecular pump of dust with a dry cloth.

Cleaning the frequency converter internally

The converter essentially requires no servicing since it contains no components which could be adjusted.

5.2 Leybold Service

Whenever you send us in equipment, indicate whether the equipment is contaminated or is free of substances which could pose a health hazard. If it is contaminated, specify exactly which substances are involved. You must use the form we have prepared for this purpose.

This form is available from www.leybold.com —> Downloads —> Download Documents.

Provide the form signed by an authorized person for each pump.

This statement detailing the type of contamination is required to satisfy legal requirements and for the protection of our employees.

We must return to the sender any equipment which is not accompanied by a contamination statement.

6 Troubleshooting

When the connector cable is attached, the outputs at the frequency converter are not free of voltage.

CAUTION



Before you start searching for the source of the problem, you should carry out a few simple checks:

Are the connections in good working order?

- Mains connection,
- 48 V DC cable to the frequency converter.

Observe the polarity.

Is the forevacuum pressure sufficient?

After having removed the cause for the error reset the error message: By applying a STOP signal via the socket REMOTE (X1), or by a reset sequence via the serial interface or by switching the mains power off.

The error codes can only be read if a serial interface is present.

The following table has been provided as a guide when determining the causes of errors.

Malfunction	Possible cause	Remedy	Shut down
Yellow power LED is not on	No DC power DC power miswired Frequency converter defective	Check cables and power supply Ensure correct polarity of the DC cable. Have the pump repaired. The following may damage the freq. converter: - Disconnection of the DC cable while the pump was still rotating - Non-compliance with the note related to connecting several pump to a single power supply.	—
Red LED flashes	Warning message.	The pump can continue to run, as long as operation limits are only exceeded for a short time. In case of longer exceeding send pump and frequency converter to the Leybold service.	no
Turbomolecular pump does not start, ERROR LED does not light.	Interface protocol error No communication via the serial interface. REMOTE connector (X1) connected wrongly.	Use USS protocol. Connect bus as shown in the interface instructions Observe Fig. 3.14.	—
Turbomolecular pump produces loud running noises and vibrations.	Rotor out of balance Bearing defective	Balance the rotor Replace the bearing	no

Troubleshooting

Malfunction	Possible cause	Remedy	Shut down
Pump overload, pump cannot keep up its speed.	Forevacuum pressure too high.	Check the ultimate pressure of the backing pump and install a bigger backing pump if req.	yes
When the speed drops below approx. 90%* of the nominal speed the red LED flashes. When this continues for more than 12 min* the pump shuts down.	Gas flow too high	Seal leak, check process	
	Fan defective	Replace fan	
	Water cooling switched off	Switch on water cooling	
Turbomolecular pump does not reach ultimate pressure.	Measurement instrument defective	Inspect the measurement sensor	no
	Measurement sensors soiled	Clean or replace the sensors	
	Leaks at the equipment, lines or the pump	Check for leaks	
	Pump soiled	Clean the pump	
	Forevacuum pump provides insufficient pumping speed or ultimate pressure which is too high.	Check the ultimate pressure of the forevacuum pump and install a higher-capacity vacuum pump if necessary	
Frequency parameters programmed wrongly	Check parameters.		
Running pump can not be stopped via X1	Pump has been started via the serial interface, the interface controls the pump	Disconnect the DC supply or connect serial interface and stop via bus	no
Connected accessories do not operate as intended	Accessories incorrectly connected or w wrong function code has been set up or function code dependent parameters have not been properly set up.	Check the settings for the function codes and the corresponding parameters OR check to ensure that the accessories have been connected to the correct accessory connection.	no

* Default values for normal operation threshold (P25) and max. run-up time (P32), can be changed via serial interface.

7 Waste Disposal

The equipment may have been contaminated by the process or by environmental influences. In this case the equipment must be decontaminated in accordance with the relevant regulations. We offer this service at fixed prices.

Contaminated parts can be detrimental to health and environment. Before beginning with any work, first find out whether any parts are contaminated. Adhere to the relevant regulations and take the necessary precautions when handling contaminated parts.

Separate clean components according to their materials, and dispose of these accordingly. We offer this service. Further details are available on request.

When sending us any equipment, observe the regulations given in Section "5.2 Leybold service".

WARNING



EU Declaration of Conformity

(Translation of original Declaration of Conformity)

The manufacturer: Leybold GmbH
Bonner Strasse 498
D-50968 Köln,
Germany

herewith declares that the products specified and listed below which we have placed on the market, comply with the applicable EU Directives. This declaration becomes invalid if modifications are made to the product without agreement of Leybold GmbH.

Product description: Turbomolecular Pumps with Integrated Frequency Converter

Type designation: TURBOVAC a1 i / DN a2 a3
TURBOVAC a1 iX / DN a2 a3

a1 = 460 to 1500 / a2 = 100 to 250 / a3 = ISO-K or ISO-F or CF

Part numbers: 8xxxxxVxxxx
x= 0 to 9

The products comply with the following Directives:

Machinery Directive (2006/42/EC)

The safety objectives of the Low Voltage Directive 2014/35/EU were complied with in accordance with Appendix 1 No. 1.5.1 of Machinery Directive 2006/42/EC.

Electromagnetic Compatibility (2014/30/EU)

Directive RoHS (2011/65/EU) & (2015/863/EU)

The following harmonized standards have been applied:

EN 1012-2:1996+A1:2009 Compressors and vacuum pumps - Safety requirements
Part 2: Vacuum pumps

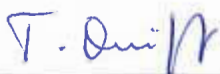
EN 61010-1:2010/A1:2019 Safety requirements for electrical equipment for measurement,
control, and laboratory use — Part 1: General requirements

EN 61326-1:2013 Electrical equipment for measurement, control and laboratory use
EMC requirements — Part 1: General requirements
Emissions: Group 1, Class B
Immunity: Industrial electromagnetic environment

Documentation office: Leybold GmbH, Bonner Straße 498, D-50968 Köln
T: +49(0)221 347 0
documentation@leybold.com

Cologne, February 03th, 2020

Cologne, February 03th, 2020



Dr. Thomas Dreifert
Engineering Manager
Product Company Cologne



Axel Güddas
General Manager
Product Company Cologne



Pioneering products. Passionately applied.

Leybold GmbH
Bonner Strasse 498
50968 Cologne
GERMANY
T: +49-(0)221-347-0
info@leybold.com
www.leybold.com