

TRIVAC[®] B-DOT

D 16 B-DOT

D 25 B-DOT

D 40 B-DOT

Operating Instructions GA01208_002_C0

Part Nos.

11406

11410

1127618

1128612

91463-1

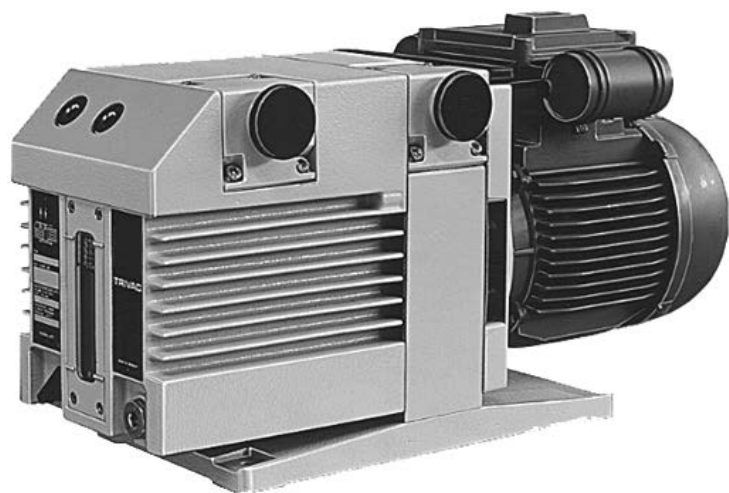

Contents

	Page
0 Important Safety Information	5
0.1 Mechanical hazards	5
0.2 Electrical hazards	5
0.3 Thermal hazards	6
0.4 Hazards caused by materials and substances	6
0.5 Danger of ignition	7
0.6 Hazard caused by noise	7
0.7 Risk of damaging the pump	8
1 Description	9
1.1 Function	10
1.2 Lubricants / Gaskets	12
1.3 Supplied Equipment	13
1.4 Technical Data	13
1.5 Accessories	16
2 Transport and Storing	17
3 Installation	18
3.1 Placement	18
3.2 Conforming Utilization	19
3.3 Connection to the System	21
3.4 Electrical Connections	22
4 Operation	24
4.1 Media Compatibility	24
4.2 Start-up	24
4.3 Operation	25
4.3.1 Pumping of Non-Condensable Gases and Vapours	25
4.3.2 Pumping of Condensable Gases and Vapours	25
4.3.3 Operating Temperature	26
4.4 Shutdown	26
4.4.1 Shutdown through Monitoring Components	27
4.4.2 Controller/Mains Power Failure	27

Contents

	Page
5 Maintenance	28
5.1 Maintenance Plan	29
5.2 Leybold Service	30
5.3 Monitoring the Oil Level	31
5.3.1 Checking the Condition of DOT-4	31
5.4 Oil Change	32
5.5 Cleaning the Inlet Screen	34
5.6 Removing and Fitting the Internal Demister	34
5.7 Disassembly and Reassembly of the Electric Motor	36
5.8 Replacing the Shaft Seal	37
5.9 Removing and Remounting the Pump Module	40
5.9.1 Removing the Pump Module	40
5.9.2 Remounting the Pump Module	41
6 Troubleshooting	42
7 Waste Disposal	44
EC Declaration of Conformity	45

Notes

NOTICE



Obligation to Provide Information

Before installing and commissioning the TRIVAC-B-DOT, carefully read these Operating Instructions and follow the information so as to ensure optimum and safe working right from the start.

The Leybold **TRIVAC-B-DOT** has been designed for safe and efficient operation when used properly and in accordance with these Operating Instructions. It is the responsibility of the user to carefully read and strictly observe all safety precautions described in this section and throughout the Operating Instructions. The pump **must only be operated in the proper condition and under the conditions described in the Operating Instructions**. It must be operated and maintained by trained personnel only. Consult local, state, and national agencies regarding specific requirements and regulations. Address any further safety, operation and/or maintenance questions to our nearest office.

DANGER



DANGER indicates an imminently hazardous situation which, if not avoided, will result in death or serious injury.

WARNING



WARNING indicates a potentially hazardous situation which, if not avoided, could result in death or serious injury.

CAUTION



CAUTION indicates a potentially hazardous situation which, if not avoided, could result in minor or moderate injury.

NOTICE



NOTICE is used to notify users of installation, operation, programming or maintenance information that is important, but not hazard related.

Figures

The references to figures, e.g. (4/2) consist of the consecutive Fig. No. and the Item No. in that order.

We reserve the right to alter the design or any data given in these Operating Instructions. The illustrations are not binding.

Retain the Operating Instructions for further use.

0 Important Safety Information

0.1 Mechanical hazards

- 1 Avoid exposing any part of the human body to the vacuum.
- 2 Never operate the pump without a connected intake line or without fitting a blank flange.
- 3 Do not operate the pump with any of the covers removed. Serious injury may result.
- 4 The location at which the TRIVAC-B-DOT (including its accessories) is being operated should be such that angles over 10° from the vertical are avoided.
- 5 The pump when filled with oil must only be moved in its vertical position. Spilled oil involves the risk of falling.
- 6 Make sure that the gas flow from the exhaust port is not blocked or restricted in any way.
- 7 If exhaust gases must be collected or contained, do not allow the exhaust line to become pressurised. The pressure in the oil box must not exceed 0.5 bar (g). An exhaust line which is too small in diameter or which is blocked can result in the formation of overpressures within the pump. Possible consequences can be a damaged or even burst open pump. Thus the exhaust line must be checked from time to time to ensure that there are no obstructions.
- 8 When moving the TRIVAC-B-DOT always use the allowed means.

WARNING



0.2 Electrical hazards

- 1 The electrical connections must only be provided by a trained electrician as specified, for example, by the regulations EN 50110-1. Observe local regulations.
- 2 Lethal voltages are present at the mains connections. Before starting with any maintenance and service work, de-energise (lockout/tagout) the product first.
- 3 Lay connecting lines so that they cannot be damaged. Protect the lines against humidity and contact with water. Avoid any heat stress on the line due to unfavourable laying conditions.
- 4 Suitably support the connecting lines so that the pumps are not exposed to any major mechanical stress.
- 5 After a mains power failure the pump will run up automatically again. This also applies in the case of an emergency shutdown. In order to prevent the pump from running up automatically again, the pump must be integrated within a control arrangement such that it can only be switched on manually again after the mains power has returned.
- 6 Provide an adequate ground connection for the pump so as to avoid any electrostatic charging.

WARNING



Safety information

CAUTION



0.3 Thermal hazards

- 1 Under certain ambient conditions the TRIVAC-B-DOT may attain a temperature of over 70 °C (158 °F). There then exists the danger of receiving burns.
Note the symbols on the pump pointing to the hazards, and in the case of a hot pump wear the required protective clothing. All work on the “pump still warm from operation” should only be done using protection gloves.
- 2 Before servicing and maintenance work always leave the pump to cool down.
- 3 Note the warning information on the housing surface. If these warning notices have been removed, covered or obstructed, include corresponding additional warning notices.

DANGER



0.4 Hazards caused by materials and substances

- 1 Before pumping oxygen (or other highly reactive gases) at concentrations exceeding the concentration in the atmosphere (> 21 % for oxygen) it will be necessary to use a special pump. Such a pump will have to be modified and degreased, and an inert special lubricant (like PFPE) must be used.
 - 2 Before commissioning the TRIVAC-B-DOT, make sure that the media which are to be pumped are compatible with each other so as to avoid hazardous situations. All relevant safety standards and regulations must be observed.
 - 3 When pumping toxic, chemical, radioactive and corrosive gases as well as pyrophorous substances, the operating company is under the obligation to comply with the national and international safety regulations and guidelines. Regarding the suitability of the TRIVAC pumps for special applications in which such gases, respectively substances shall be pumped, Leybold should be consulted first.
 - 4 If the pump has previously handled hazardous gases, implement the proper precautionary measures before opening the intake or exhaust connection.
Before opening the pump, purge it for a longer period of time with an inert gas.
If necessary, use gloves, a respirator and/or protective clothing and work under an exhaust hood. Firmly seal off the pump.
When shipping the contaminated pump for servicing, please also state the type of hazard. For this you must use a form which we have prepared for you.
 - 5 Contaminated parts can be detrimental to health and environment. Before beginning with any work, first find out whether any parts are contaminated. Adhere to the relevant regulations and take the necessary precautions when handling contaminated parts.
-

0.5 Danger of ignition

- 1 The standard version of the TRIVAC-B-DOT is **not** suited for operation in explosion hazard areas.
- 2 The TRIVAC pumps including the accessories are fundamentally **not** suited for pumping of combustible and explosive gases or vapours. Mixtures of substances may, regarding the fire and explosion risk be critical or uncritical. The operating company is under the commitment to analyse this and rate the hazard potential accordingly so as to therefrom derive the necessary safety measures which must be introduced.
- 3 Provided ignitable or pyrophorous substances are present in the equipment you must:
 - ensure that no air can enter into the equipment,
 - ensure that the system is leak-tight,
 - with an inert gas purge (with nitrogen, for example) dilute all ignitable gases or vapours which may enter into the pump through the pump's inlet and/or with an inert gas purge reduce the concentration of ignitable gases or vapours in the pump and in the exhaust line to less than a quarter of the lower explosion limit (LEL) published for the respective gases.

CAUTION



0.6 Hazard caused by noise

- 1 The noise level produced by the pump less than 60 dB(A). Suitable hearing protection measures must be introduced.

CAUTION



Safety information

NOTICE



0.7 Risk of damaging the pump

- 1 Before starting up for the first time, the motor circuit must be equipped with a suitable protective motor switch. Please take note of the information in these Operating Instructions and on the electric motor (wiring diagram).
- 2 Do not allow the ingestion of small objects (screws, nuts, washers, pieces of wire, etc.) through the inlet port. For this reason always use the inlet screen which is supplied as standard.
- 3 Do not use the pump for applications that produce abrasive or adhesive powders or condensable vapours that can leave adhesive or high viscosity deposits. When planning to pump vapours other than water vapour please contact our sales or service department for advice.
- 4 This pump is suited for pumping water vapour within the specified water vapour tolerance limits.
- 5 Avoid vapours that can condense into liquids when being compressed inside the pump, if these substances exceed the vapour tolerance of the pump.
- 6 Before pumping vapours the TRIVAC-B-DOT should have attained its operating temperature. This will be the case approximately 30 minutes after having started the pump. During this warming up phase, the pump should be separated from the process, by a blocking valve in the intake line, for example.
- 7 In the case of wet processes we recommend the installation of liquid separators upstream and downstream of the pump as well as the use of the gas ballast.
- 8 The exhaust line should be laid so that it slopes down and away from the pump so as to prevent condensate from backstreaming into the pump.
- 9 The entry of particles and fluids must be avoided under all circumstances.
- 10 Reactive or aggressive substances in the pump chamber may impair the operating oil or modify it. In addition, such substances may be incompatible with the materials of the pump (Viton, grey cast iron, aluminium, steel, resins, glass etc.).
- 11 Corrosion, deposits and cracking of oil within the pump are not allowed.
- 12 Normal amounts of humidity within the range of the pump's water vapour tolerance will not significantly affect pump performance when the gas ballast is active.
- 13 When operating the pumps at gas throughput, it is urgently recommended to connect an exhaust filter or use a suitable exhaust line. Here, the exhaust line must slope down and away from the pump.
- 14 In the case of custom pumps please note the information provided in the supplementary sheets.

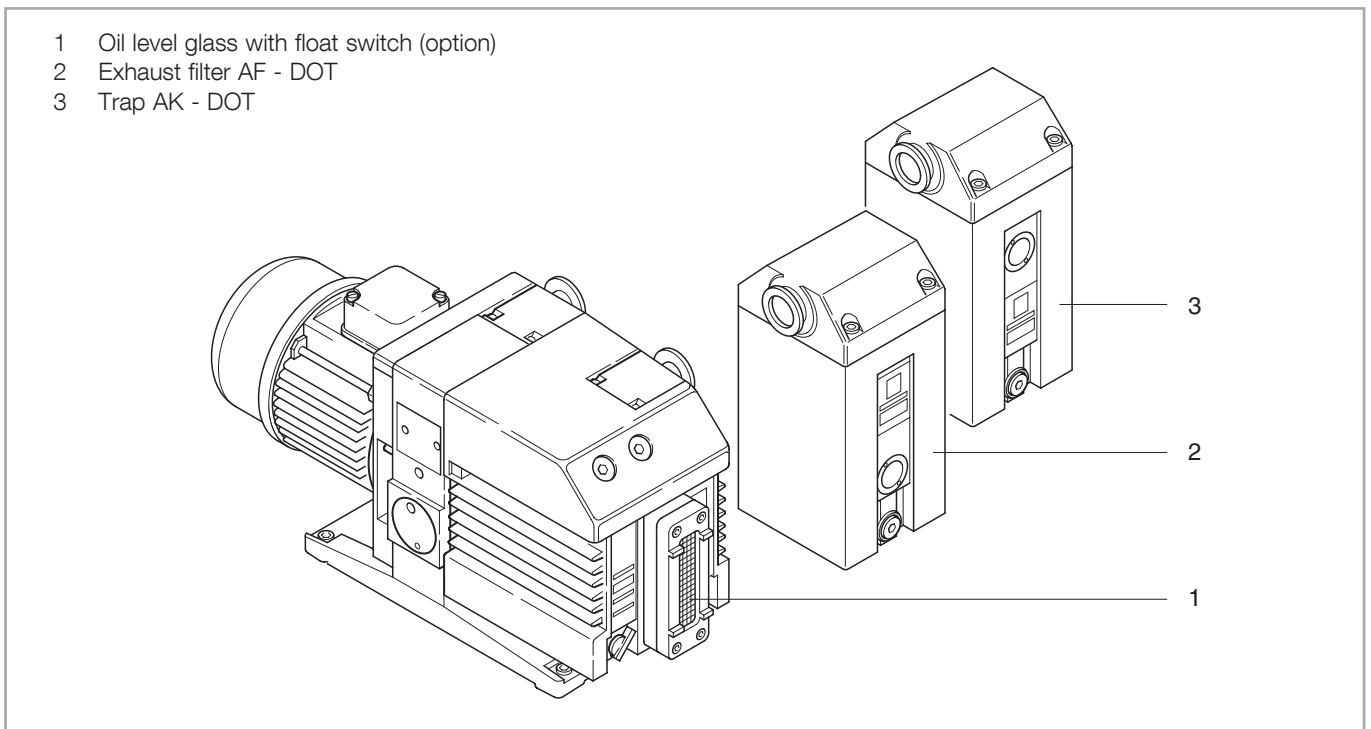

Fig. 1 TRIVAC-B-DOT with accessories and float switch

1 Description

TRIVAC-B-DOT pumps are oil-sealed rotary vane pumps having either a single stage or two stages. The number in the type designation indicates the pumping speed in $\text{m}^3 \cdot \text{h}^{-1}$.

TRIVAC-B-DOT pumps can pump gases and vapours. They are used to evacuate brake systems and to degas hydraulics liquids.

Via an intermediate flange the drive motor of the TRIVAC is mounted to the coupling housing. The pump and motor shafts are directly connected by a flexible coupling. The bearing points of the pump module are force lubricated sliding bearings. All controls as well as the oil level glass and the nameplate are arranged on the front. All connections are to be found at the sides of the pump. The oil-level glass is provided with prisms for better observation of the oil level.

The pump module consists of assembly parts which are pin-fitted so as to allow easy disassembly and reassembly. The pump module can be easily removed without special tools.

TRIVAC-B-DOT pumps are equipped with special seals capable of resisting brake fluids.

NOTICE



Description

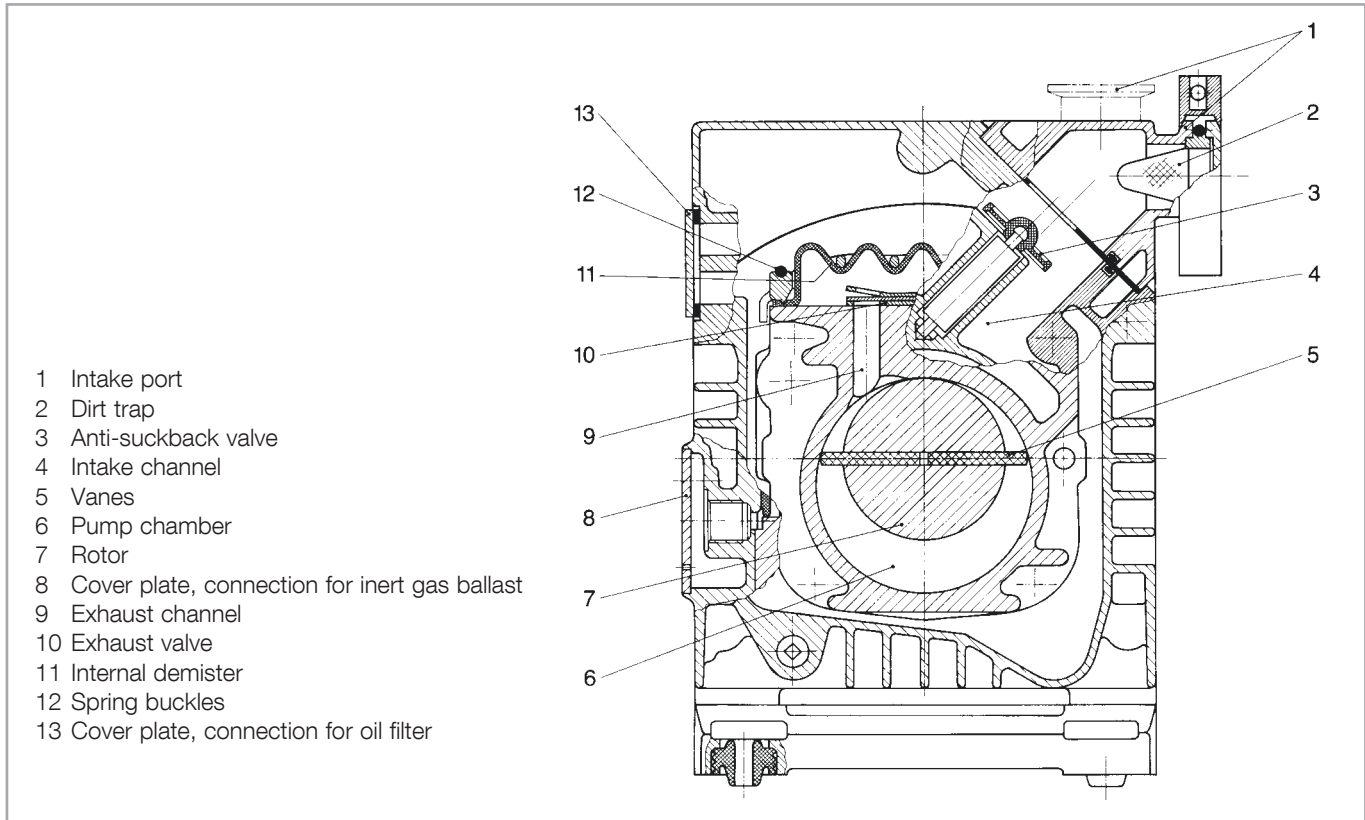

Fig. 2 Schnitt durch eine TRIVAC-B-DOT

1.1 Function

The rotor (2/7), mounted eccentrically in the pump housing (2/6), has two radially sliding vanes (2/5) which divide the pump chamber into several compartments. The volume of each compartment changes periodically with the rotation of the rotor.

As a result, gas is sucked in at the intake port (2/1). The gas passes through the dirt trap sieve (2/2), flows past the open anti-suckback valve (2/3) and then enters the pump chamber. In the pump chamber, the gas is passed on and compressed, after the inlet aperture is closed by the vane.

The oil injected into the pump chamber is used for sealing and lubricating. The slap noise of the oil in the pump which usually occurs when attaining the ultimate pressure is prevented by admitting a very small amount of air into the pump chamber.

The compressed gas in the pump chamber is ejected through the exhaust valve (2/10). The oil entrained in the gas is coarsely trapped in the internal demister (2/11); there the oil is also freed of mechanical impurities. The gas leaves the TRIVAC-B-DOT through the exhaust port.

During compression, a controlled amount of air – the so-called gas ballast – can be allowed to enter the pump chamber by opening the gas ballast valve. The gas ballast stops condensation of vapours in the pump chamber up to the limit of the water vapour tolerance as specified in the technical data for the pump.

The gas ballast valve is opened (position I) and closed (position O) by turning the gas ballast knob (7/5) on the front.

To enable the TRIVAC-B-DOT to be used at intake pressures as high as 1,000 mbar, a special lubricating system was developed featuring force-lubrication of the sliding bearings.

An oil pump (3/6) pumps the oil from the oil reservoir (3/5) into a pressure-lubrication system which supplies oil to all bearing points (3/2). From there the oil enters the pump chamber area (3/4) of the vacuum pump.

The oil pump is fitted in the front end plate on the coupling side of the pump module. The oil suction line is placed low, resulting in a large usable oil reservoir.

The oil is separated from the gas in the TRIVAC-B-DOT in two steps as described above. First, small droplets are coalesced into large drops in the internal demister (2/11) fitted above the exhaust valve (2/10). Then, the large drops fall into the oil reservoir as the exhaust gas is diverted by the inner walls of the oil case. Thus a low loss of oil is obtained. This and the large usable oil reservoir ensure long intervals between oil changes even at high intake pressures.

The vacuum is maintained by the TRIVAC-B-DOT through an integrated hydropneumatic anti-suckback valve (2/3) which is controlled via the oil pressure.

During operation of the TRIVAC-B-DOT the control piston (4/3) remains sealed against a spring (4/2) by the oil pressure. The valve disk (4/6) of the anti-suckback valve is held at the lower position by its own weight (valve open). When the pump stops (because it has been switched off or because of a failure), the oil pressure drops and the spring (4/2) presses the control piston (4/3) up. Thus a connection is provided between the oil case or the oil reservoir (4/1) and the piston (4/4) of the anti-suckback valve.

Due to the pressure difference between the oil case and the intake port the oil presses the piston (4/4) up and the valve plate (4/6) against the valve seat (4/5). The quantity of oil in the oil reservoir (4/1) prevents the entry of air into the intake port (2/1) at the beginning of this process.

After the oil has flowed out from the reservoir and when the valve plate rests on the valve seat, air follows in, which vents the pump chamber and forces the valve disc (4/6) against its seat. This effectively prevents backstreaming of oil or oil vapours. The anti-suckback valve (2/3) operates independently of the operating mode of the pump, i.e. also with gas ballast.

Description

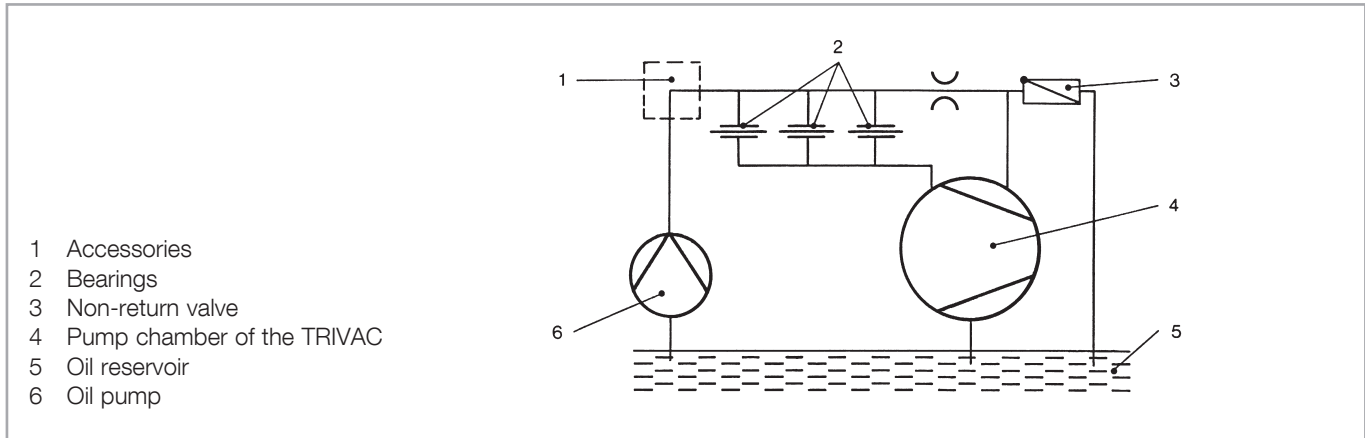

Fig. 3 Schematic of the lubricating system

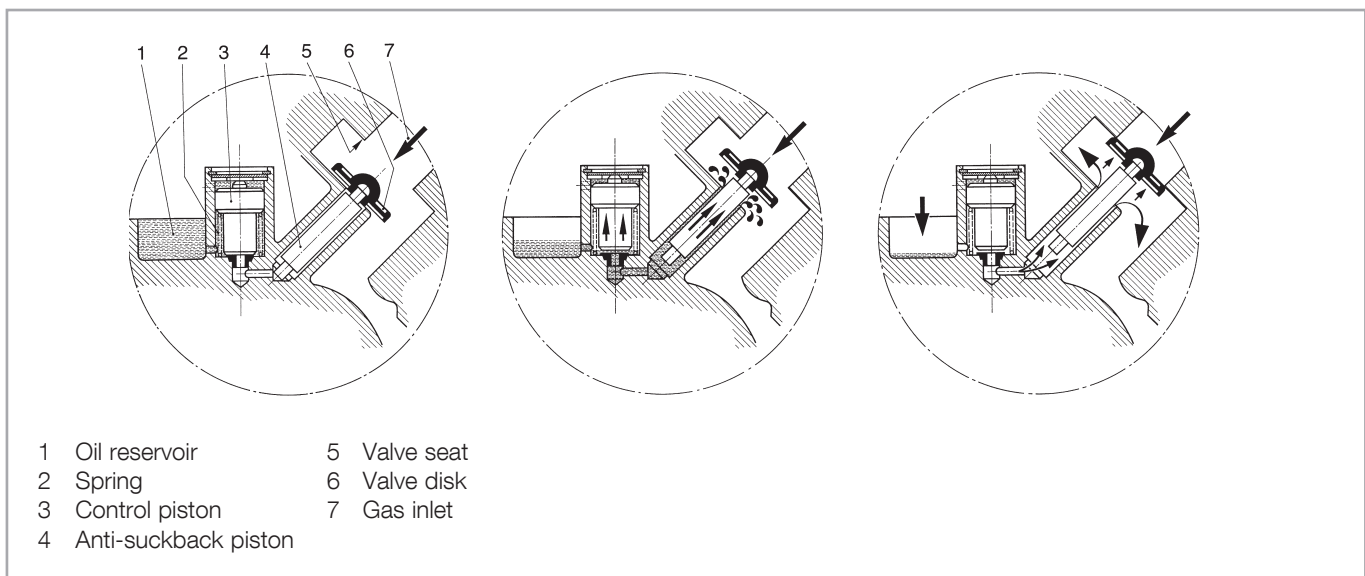

Fig. 4 Hydropneumatic anti-suckback valve

1.2 Lubricants / Gaskets

These pumps must only be operated with brake fluids in accordance with DOT-3 and DOT-4 or alternative operating agents which have been approved by Leybold.

TRIVAC-B-DOT pumps and accessories are equipped with special seals which are capable of resisting exposure to brake fluids.

1.3 Supplied Equipment

The equipment supplied with the TRIVAC pump includes:

- Pump with a motor,
- Pump filled with brake fluid according to DOT-4,
- 1 centering ring,
- 1 centering ring with dirt trap,
- 2 clamping rings,
- Operating Instructions,
- Spare Parts List.

For protection, the connection ports are each blanked off by rubber diaphragms and supporting rings.

The part number 914 63-1 is delivered with the oil Ucon LB300-XY26.

1.4 Technical Data

TRIVAC-B-DOT		D 16 B-DOT	D 25 B-DOT	D 40 B-DOT
Nominal pumping speed ¹⁾	m ³ · h ⁻¹	18.9	29.5	46
Pumping speed ¹⁾	m ³ · h ⁻¹	16.5	25.7	40
Ultimate partial pressure without gas ballast ¹⁾	mbar	10 ⁻⁴	10 ⁻⁴	10 ⁻⁴
Ultimate total pressure without gas ballast ¹⁾	mbar	< 6 · 10 ⁻¹	< 6 · 10 ⁻¹	< 6 · 10 ⁻¹
Ultimate total pressure with gas ballast ¹⁾	mbar	< 9 · 10 ⁻¹	< 9 · 10 ⁻¹	< 9 · 10 ⁻¹
Water vapour tolerance ¹⁾	mbar	25	25	40
Water vapour capacity	g · h ⁻¹	305	476	1184
Oil filling, min./max.	l	0.45 / 1.0	0.6 / 1.4	1.7 / 2.6
Noise level to DIN 45 635, (without/with gas ballast)	dB (A)	54 / 56	54 / 56	57 / 59
Admissible ambient temperatur	°C	+12 ... +40	+12 ... +40	+12 ... +40
Weight	kg	26	32	68
Connections, intake and exhaust side	DN	25 KF	25 KF	40 KF

¹⁾To DIN 28 400 and subsequent numbers

In the case of custom pumps please note the information provided in the supplementary sheets.

NOTICE



Description

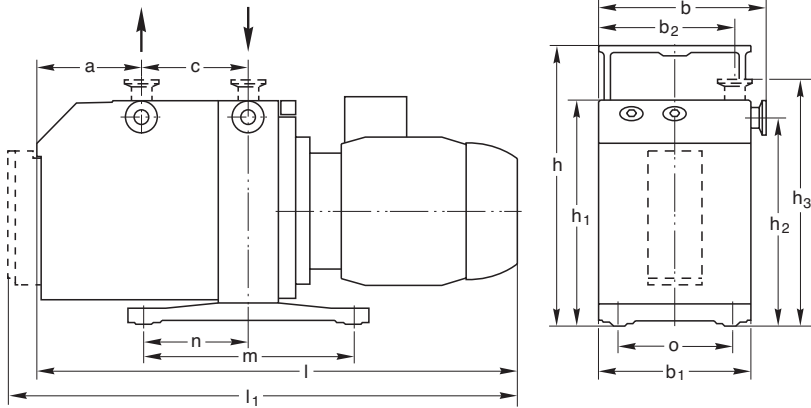

Dimensional drawing for the TRIVAC
D 16 B - DOT, D 25 B - DOT

		a	b	b ₁	b ₂	c	h	h ₁	h ₂	h ₃	m	n	o
D 16 B	25 KF	82	190	175	150	135	298	250	226	263	280	140	132
D 25 B	25 KF	143	190	175	150	135	298	250	226	263	280	140	132

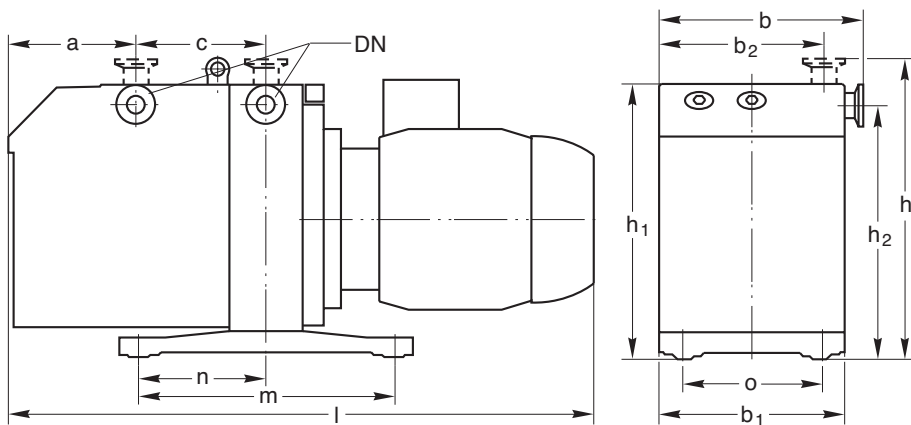





Dimensional drawing for the TRIVAC
D 40 B - DOT

	DN	a	b	b ₁	b ₂	c	h	h ₁	h ₂	m	n	o
D 40 B	40 KF	135	254	234	206	166	355	336	308	382	191	190

Fig. 6 Dimensional drawings for the TRIVAC-B-DOT
(Dimensions a, l, b to b₂ and h₁ are approximate, dimensions in mm)

Description

Cat. No. of the pumps	1128612	1127618, 11406, 11410, 91463-1
Motor type	AMH 100L AA4	AMH 80Z AA4
Motor L/N	6506961	6506939
Compliance Certification number	CC046A	CC046A
IP rating	IP 55	IP 55
Operating mode IEC34	S1	S1
Isolation class	F	F
Phases	3~	3~
Nom. efficiency (η) at nom. voltage:		
50 Hz and 100 % of nom. load	85.9 % (at 400 V)	80.4 % (at 400 V)
50 Hz and 75 % of nom. load	85.9 % (at 400 V)	81.3 % (at 400 V)
50 Hz and 50 % of nom. load	83.9 % (at 400 V)	79.6 % (at 400 V)
60 Hz and 100 % of nom. load	87.9 % (at 460 V)	82.7 % (at 400 V)
60 Hz and 75 % of nom. load	87.1 % (at 460 V)	82.1 % (at 400 V)
60 Hz and 50 % of nom. load	84.5 % (at 460 V)	79.2 % (at 400 V)
Efficiency class	IE2 EPAct	IE2 EPAct
Manufacturer	Lafert SpA San Donà di Piave Italy	Lafert SpA San Donà di Piave Italy
Number of poles	4	4
Nom. output power at 50 Hz	2200 W	750 W
Nom. output power at 60 Hz	2200 W	750 W
Nom. in frequency	50 Hz 60 Hz	50 Hz 60 Hz
Nom. voltage range and nom. current at 50 Hz	200-240 V / 15.0 A 200 V / 10.4 A (IE2) 380-400 V / 5.2 A 380-400 V / 5.2 A (IE2)	200-240 V / 3.6 A 200 V / 3.6 A (IE2) 380-400 V / 1.8 A 380-400 V / 1.8 A (IE2)
Nom. voltage range and nom. current at 50 Hz	200-240 V / 12.0 A 208-240 V / 9.2 A (EPAct) 380-480 V / 5.2 A 416-480 V / 4.6 A (EPAct)	200-240 V / 3.4 A 208-240 V / 3.2 A (EPAct) 380-480 V / 1.7 A 416-480 V / 1.6 A (EPAct)
Tolerances of voltage range ¹⁾	±10 %	±10 %
Nom. speed at 50 Hz	1430 min ⁻¹	1430 min ⁻¹
Nom. speed at 60 Hz	1735 min ⁻¹	1740 min ⁻¹
Disposal	local directives have to be considered	local directives have to be considered
Max. altitude above sea level	1000 m above sea level	1000 m above sea level
Max. ambient temperature when operating ¹⁾	40 °C	40 °C
T-board / plug	9 pin	9 pin
Certificates ²⁾ of the motor	 RoHS 	 RoHS 
length of the pump	720 mm (D 40 B)	508 mm (D 16 B) 570 mm (D 25 B)

Description

¹⁾The motor may accelerate with a delay when simultaneously an undervoltage is present at the motor and the pump is at the minimum permissible and ambient temperature. Under such operating conditions the motor protection switch may respond. In this case the motor may be started again. In the case of motor 6506961 the minimum permissible temperature is 15 °C at an undervoltage of 380 V -10% = 342 V and a mains frequency of 60 Hz.

²⁾Key to the certificates:



UL certification mark for approved components for the USA.



UL certification mark for energy efficiency for listed products and approved components for Canada and the USA.

Observe the data given on the motor name plate.

NOTICE



For special pumps please note the information contained in the supplemental sheet.

1.5 Accessories

	Part Nos.
Exhaust filter AF 16-25 DOT	124 16
Exhaust filter AF 40-65 DOT	upon request
Condensate trap AK 16-25 DOT	upon request
AR 16-25 DOT	upon request
Float switch LSS 16-25 for all models	200 39 838
FE 40-65 für AF 40-65	200 39 840

NOTICE



Use only the kind of accessories specified by Leybold

Transport and Storing

2 Transport and Storing

To lift the pumps only use the handle provided for this purpose, respectively use corresponding lifting facilities. When connecting or removing the pump, do not move under hoisted loads.

If possible transport the pump in its original packaging, if not available exercise due care.

Pumps which are filled with operating agents must only be moved while standing upright. Otherwise oil may escape. Avoid any other orientations during transport. Check the pump for the presence of any oil leaks, since there exists the danger that someone may slip on spilt oil.

Before putting a pump into operation once more it should be stored in a dry place preferably at room temperature (20 °C). Before the pump is shelved it must be properly disconnected from the vacuum system, purged with dry nitrogen and the oil should be changed too.

The inlets and outlets of the pump must be sealed with the shipping seals which are provided upon delivery.

The gas ballast switch must be set to the „0“ position and if the pump is to be shelved for a longer period of time it should be sealed in a PE bag containing some desiccant (silica gel).

When a pump is put into operation after it has been shelved for over one year, standard maintenance should be run on the pump and the oil should also be exchanged (see Section 5.4). We recommend that you contact the Leybold Service.

CAUTION



Installation

NOTICE**3 Installation**

Instructions for the operating personnel
Before any kind of assembly work the personnel must be informed about to potential hazards. Observe Safety Informations 0.1 to 06.

DANGER**3.1 Placement**

Explosion risk
The standard pump is not suited for installation in the explosion hazard areas. When planning such an application please contact us first.
Observe Safety Informations 0.5.

The TRIVAC-B-DOT pump can be set up on a flat, horizontal surface. Rubber feet under the coupling housing ensure that the pump can not slip.
The location of the TRIVAC-B-DOT should be such that all controls are easily accessible.

CAUTION

Risk of toppling
Max. tilt for the pump is 10° from the vertical.

If you wish firmly install the pump in place, insert bolts through bore holes in the rubber feet.

NOTICE

The rubber feet act as vibration absorbers. They must therefore not be compressed by screws.
The site chosen should allow adequate air circulation to cool the pump (keep front and rear unobstructed).
The oil-level glass must be visible.

NOTICE

Note the ambient conditions during operation
The ambient temperature should not exceed +40 °C (104 °F) and not drop below +12 °C (55 °F) (see Section 4.3.3).
For installation sites over 1000 m above sea level and/or a relative atmospheric humidity of over 90%, you must discuss this with Technical Sales.
Maximum heat dissipation corresponds approximately to the installed motor power.

When failing, capacitors may heat up excessively and generate smoke. Therefore the pump must be placed with a sufficient clearance from inflammable or combustible material. There exists the risk of fire!

3.2 Conforming Utilization

The TRIVAC-B-DOT- have been prepared especially for operation with perfluoropolyther.

TRIVAC-B-DOT pumps can pump gases and vapours, and evacuate vessels or vacuum systems in the fine vacuum range.

They are not suited for operation in explosion hazard areas.

The pumps are suited for pumping water vapour within the specified water vapour tolerance limits. Avoid vapours that can condense into liquids when being compressed inside the pump, if these substances exceed the vapour tolerance of the pump. In the case of wet processes we recommend the installation of liquid separators upstream and downstream of the pump as well as the use of the gas ballast.

Pumping of dust or much contaminated media

The pumps are not suited for pumping of liquids or media which carry large quantities of dust. Corresponding protection devices need to be provided.

The TRIVAC-B-DOT is not suited for pumping of:

- combustible and explosive gases or vapours
- Oxidant
- pyrophorous substances.

Our technical sales department is available for further advice in these matters.

NOTICE



Installation

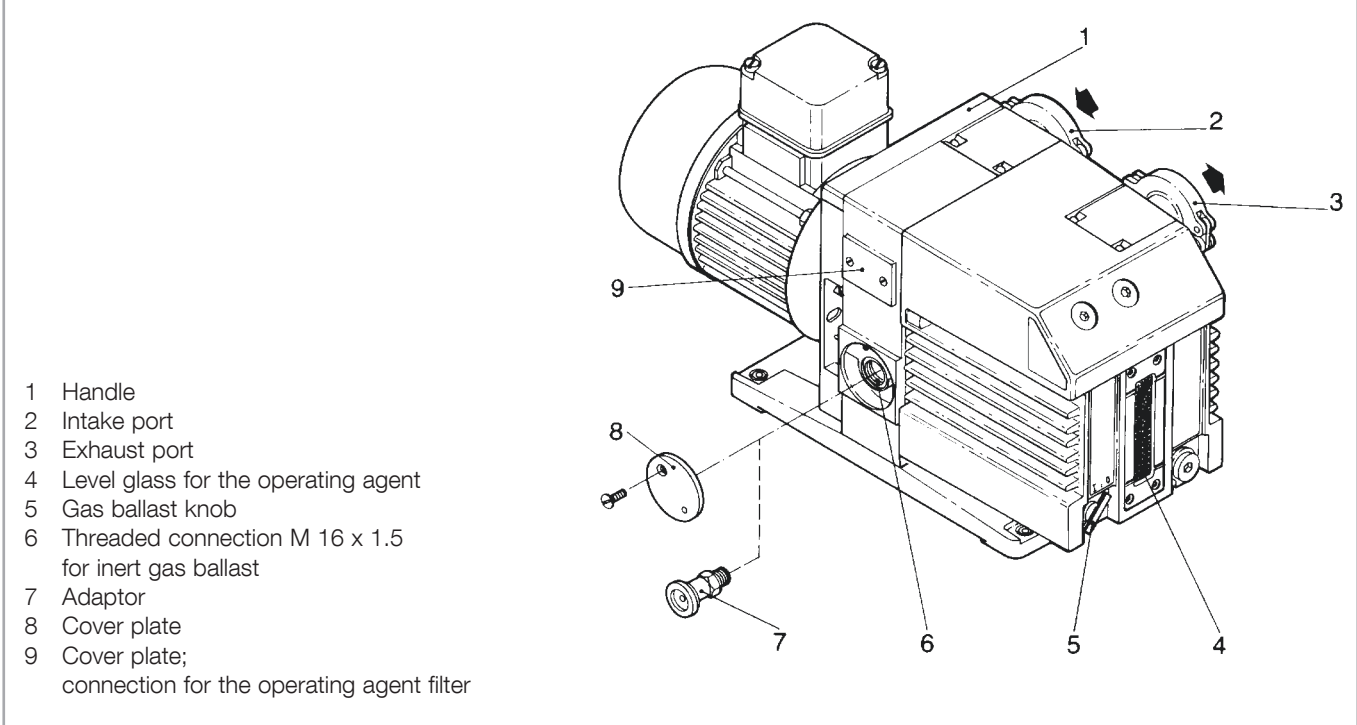

Fig. 7 Connections and controls

3.3 Connection to the System

Before connecting the TRIVAC-B-DOT, remove the shipping seals from the connection flanges (7/2) and (7/3).

Retain the shipping seals in case you need to store the pump in the future.

The pump is shipped with intake and exhaust flanges mounted for horizontal connection of the connecting lines. You can easily convert the ports for vertical connection by removing the four capscrews, rotating the flanges as required, and reinstalling the capscrews. Connect the intake and exhaust lines with a centering ring and a clamping ring each. Use the centering ring with dirt trap for the intake port.

Connect the intake and exhaust line using anti-vibration bellows, without placing any strain on the pump.

The intake line must be clean. Deposits in the intake line may outgas and adversely affect the vacuum. The connecting flanges must be clean and undamaged.

The maximum throughput of the pump is equivalent to the pumping speed of the pump.

Note the specified cross sections for the connection lines

If exhaust gases must be collected or contained, do not allow the exhaust line to become pressurised. The pressure in the oil box must not exceed 0.5 bar (g). An exhaust line which is too small in diameter or which is blocked can result in the formation of overpressures within the pump. Possible consequences can be a damaged or even burst open pump. Thus the exhaust line must be checked from time to time to ensure that there are no obstructions.

Never operate the pump with a sealed exhaust line. There is the danger of injury.

Avoid backflowing condensate

Install the exhaust line with a downward slope (lower than the pump) so as to prevent condensate from flowing back into the pump. If this is not possible, insert a condensate trap.

CAUTION



NOTICE



Installation

CAUTION

Safely lead the exhaust gases away

Exhaust gases may, depending on the type of application, present a health hazard and/or may be detrimental to the environment.

The exhaust gases from the vacuum pump must be safely led away and subjected to post-treatment as required. In order to reduce the emission of oil vapours we recommend the installation of an additional exhaust filter (Leybold accessory, see Section 1.5). Depending on the type of application or the kind of pumped media, the corresponding regulations and information sheets must be observed.

NOTICE

When oil mist is to be removed from the exhaust flow we recommend the use of the exhaust filter with lubricant return (ARS) which is part of the TRIVAC system.

The maximum intake pressure must not exceed atmospheric pressure (1013 mbar).

The pumps may be operated with an inert gas ballast via a connection which is provided for this purpose. The cover plate (7/8) can be removed to gain access to this M 16 x 1.5 threaded port (7/6). Matching connectors are available (see Section 1.5).

In inlet pressure for the gas ballast should be about 1013 mbar (absolute) and sufficient quantities of gas must be available (about $\frac{1}{10}$ of the pumping speed).

3.4 Electrical Connections

TRIVAC B pumps are supplied with three-phase motor but without accessories for electrical connection. They must be connected via the appropriate cable, and a suitable motor protection switch.

When operating the unit at its operational limits (at an ambient temperature of 12 °C and at undervoltage, for example) it may be necessary to protect the electric motor against high start-up currents by installing an overload protector (Class 20 in accordance with IEC 60947, for example). Set up according to the information provided on the motor nameplate to meet local requirements for the motor protection switch. The local requirements may specify measures for reducing the start-up current (soft start, frequency controlled start-up, for example). Set the switch in accordance with the rating on the motor nameplate.

Please observe the diagram at the motor.

After connecting the motor and after every time you alter the wiring, check the direction of rotation. To do so, briefly switch on the motor and check whether a suitable cover (e. g. a blank flange) is sucked on at the intake port. If not, interchange two phases of the connection.

Observe the direction arrow on the intermediate flange.

In the case of custom pumps please note the information provided on a separate sheet.

Risk due to high voltages

Death or severe injury caused by an electric shock!

The electrical connections must only be provided by a trained electrician as specified, for example, by the regulations EN 50110-1. Note the national regulations of the country in which the equipment is being operated.

During all connection work, the mains power supply lines must be de-energised (lockout/tag out). In order to prevent the pump from running up unexpectedly after a mains power failure, the pump must be integrated in the control system in such a way that the pump can only be switched on again manually. This applies equally to emergency cut-out arrangements. Observe Safety Informations 0.2.

DANGER

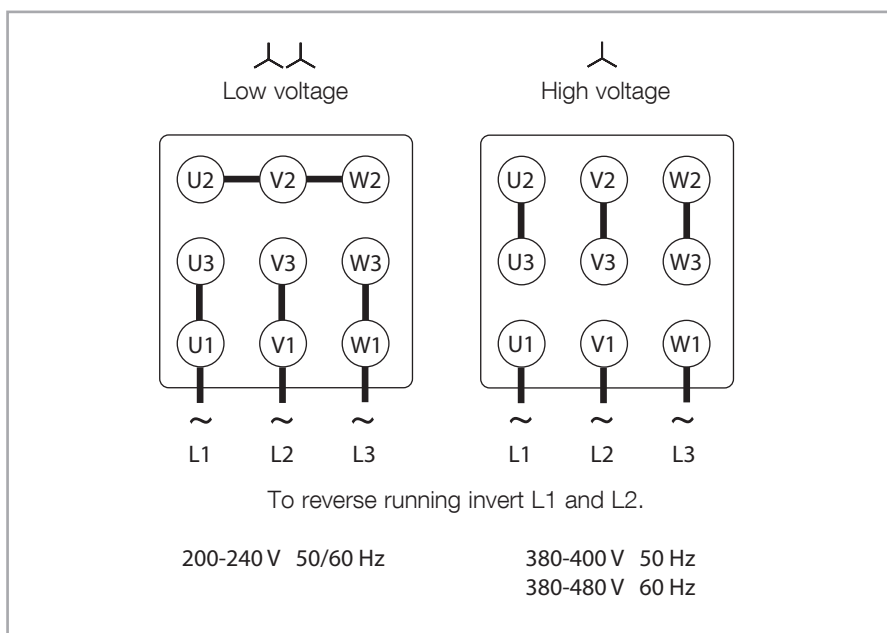

Fig. 8 Motor connection diagram (motor P/N: 6506961 and 6506939)

4 Operation

4.1 Media Compatibility

TRIVAC-B-DOT pumps can pump condensable gases and vapours, provided that the gas ballast valve is open and the pump has attained its operating temperature.

4.2 Start-up

NOTICE

TRIVAC-B-DOT pumps must only be operated in connection with brake fluid filling and degassing systems.

Each time before starting up check the oil level. The pump must never be operated with an oil level below the minimum.

Open all valves blocking the exhaust lines. The pump must never be operated with a blocked or constricted exhaust line.

Do not select a degassing pressure of less than 1 mbar, since at this pressure volatile substances in the brake fluid may escape and damage the elastomer seals of the pump.

Check the direction of rotation before starting the pump for the first time and after each change in the electrical connection (see Chapter 3.4).

On initial start-up, after prolonged idle periods or after an oil change, the specified ultimate pressure cannot be attained until the oil is degassed.

This can be done by running the pump for approx. 30 min. with the intake line closed and the gas ballast valve (7/5) open.

WARNING

Use matching accessories only

Before starting the pump ensure that the pump and the fitted accessories meet the requirements of your application and that safe operation can be guaranteed.

WARNING

Start up the pump only after it has been fully installed

Never operate the pump with an open intake port. Vacuum connections as well as oil feed and discharge openings must not be opened while the pump is operating. Avoid exposing any part of the human body to the vacuum. There is the risk of suffering injury.

Observe Safety Informations 0.1.

4.3 Operation

If exhaust gases must be collected or contained, do not allow the exhaust line to become pressurised. The pressure in the oil box must not exceed 0.5 bar (g). An exhaust line which is too small in diameter or which is blocked can result in the formation of overpressures within the pump. Possible consequences can be a damaged or even burst open pump. Thus the exhaust line must be checked from time to time to ensure that there are no obstructions.

WARNING



4.3.1 Pumping of Non-Condensable Gases and Vapours

If the process contains mainly permanent gases, the TRIVAC-B-DOT may be operated without gas ballast (position 0), provided that the saturation vapour pressure at operating temperature is not exceeded during compression.

If the composition of the gases to be pumped is not known and if condensation in the pump cannot be ruled out, run the pump with the gas ballast valve open and with dry inert gas in accordance with Section 4.3.2.

4.3.2 Pumping of Condensable Gases and Vapours

With the gas ballast valve open (position I) and at operating temperature, TRIVAC-B-DOT pumps can pump pure water vapour up to the water vapour tolerance specified by the technical data. If the vapour pressure increases above the permissible level, the water vapour will condense in the oil of the pump.

When pumping vapours ensure that the gas ballast valve is open and that the pump has been warmed up for approximately 30 minutes with the intake line closed.

Pumping of Vapours

Vapour phases may only be pumped up to the permissible limit after the pump has attained its operating temperature.

During pumping, vapours may dissolve in the oil. This changes the oil properties and thus there is a risk of corrosion in the pump. Therefore, don't switch off the pump immediately after completion of the process. Instead, allow the pump to continue operating with the gas ballast valve open and the intake line closed until the oil is free of condensed vapours.

We strongly recommend operating the TRIVAC-B-DOT in this mode for about 30 minutes after completion of the process.

NOTICE



In cyclic operation, the TRIVAC-B-DOT should not be switched off during the intervals between the individual working phases (power consumption is minimal when the pump is operating at ultimate pressure), but should continue to run with gas ballast valve open and intake port closed (if possible via a valve).

Once all vapours have been pumped off from a process (e.g. during drying), the gas ballast valve can be closed to improve the attainable ultimate pressure.

Operation

4.3.3 Operating Temperature

Proper operation of the TRIVAC-B-DOT is ensured in the ambient temperature range between 12 °C to 40 °C (55 °F to 104 °F).

At operating temperature, the surface temperature of the TRIVAC-B-DOT may lie over 70 °C (156 °F).

CAUTION



Beware of hot surfaces
There is the danger of receiving burns.
Observe Safety Informations 0.3.

If – due to the ambient conditions – this temperature range is exceeded at either end of the range, contact Leybold Sales.

The motor may accelerate with a delay when simultaneously an undervoltage is present at the motor and the pump is at the minimum permissible and ambient temperature.

Under such operating conditions the motor protection switch may respond. In this case the motor may be started again.

In the case of motor 6506961 the minimum permissible temperature is 15 °C at an undervoltage of 380 V -10% = 342 V and a mains frequency of 60 Hz.

4.4 Shutdown

If the pump was exposed to aggressive and corrosive media, we recommend that you let the pump continue to operate even during long non-working intervals (e.g. overnight) with the intake line closed and the gas ballast valve open. This avoids corrosion during idle periods and difficulties when re-starting the pump under conditions where the lubricant has been chemically modified.

CAUTION



When pumping condensable media let the pump continue to operate with the gas ballast valve open and the intake line closed before switching off (see Chapter 4.3.2).

If the TRIVAC-B-DOT is to be shutdown for an extended period after pumping aggressive or corrosive media or if the pump has to be stored, proceed as follows:

WARNING



Pump and operating agents may be contaminated
If hazardous substances have been pumped, then these substances can escape from the pump and from the oil. Introduce adequate safety precautions; use gloves, face protection or a respirator, for example. Observe Safety Informations 0.4.

Drain the oil (see Chapter 5.4).

Add clean oil until the oil-level is at the “min” mark and let the pump operate for some time.

Then drain the oil and add clean oil until the oil level is at the “max.” mark.

Seal the connection ports. Special conservation or anti-corrosion oils aren't necessary.

Please also take note of the information given in Section 2 Transport and Storing.

4.4.1 Shutdown through Monitoring Components

When the pump has been switched off by monitoring components at the pump (e. g. thermal sensor), the pump must only be started manually after the pump has cooled down to the ambient temperature and after having removed the cause first.

CAUTION



4.4.2 Controller/Mains Power Failure

In order to prevent the pump from running up unexpectedly after a mains power failure, the pump must be integrated in the control system in such a way that the pump can only be switched on again manually. This applies equally to emergency cut-out arrangements

CAUTION



5 Maintenance

DANGER

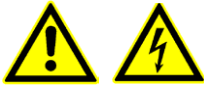

Danger by High Electric Voltages

Death or severe injury caused by an electric shock!

The electrical connections must only be provided by a trained electrician as specified, for example, by the regulations EN 50110-1. Note the national regulations of the country in which the equipment is being operated.



Disconnect the electrical connections before disassembling the pump. Make absolutely sure that the pump cannot be accidentally started. Observe Safety Informations 0.2.

Capacitors of security class P2 (IAW EN 60252) are used with the pump's single-phase AC motors. The capacitor's life cycle is 10,000 h (life cycle category B acc. to EN 60252). Therefore we recommend to replace motor or capacitor before reaching the end of its life cycle.

If the pump has pumped harmful substances, contrary to what has been stated in Section 3.2, ascertain the nature of hazard and take adequate safety measures. Observe Safety Informations 0.4.

When disposing of used oil, you must observe the applicable environmental regulations!

Due to the design concept, TRIVAC-B-DOT pumps require very little maintenance when operated under normal conditions. The work required is described in the sections below. In addition to this, a maintenance plan is provided in Section 5.1.

NOTICE



All work must be carried out by suitably trained personnel. Maintenance or repairs carried out incorrectly will affect the life and performance of the pump and will void any warranty claims.

Leybold offers practical courses on the maintenance, repair, and testing of TRIVAC-B-DOT pumps. Further details are available from Leybold on request.

NOTICE



If the TRIVAC-B-DOT is used in ambient air which is much contaminated, make sure that the air circulation and the gas ballast valve are not adversely affected.

When the TRIVAC-B-DOT has been pumping corrosive media we recommend that possibly planned maintenance work be carried out immediately in order to prevent corrosion of the pump while it is at standstill.

In case of special designs and variants please always indicate the serial number.

5.1 Maintenance Plan

No.	Rotary vane pump TRIVAC-B-DOT	Measurement/test quantity Operating/auxiliary materials	Interval						Remarks
			VE	VP	t	6m	a	n-a	
1	Operate the pump for at least 1 h with gas ballast.				x				Condensed water is thus removed from the oil.
2	Check the oil level, if required change the oil.	Oil: DOT-4 or special and alternative oils see Chapter 1.2	x		x				Refill: Only after the pump has been switched off.
3	Clean the inlet screen in the intake port, change it as required.	Suitable cleaning agent and compressed air.				x			<ul style="list-style-type: none"> ■ Clean inlet screen with a cleaning agent and blow it out with compressed air under a suction hood. ■ Replace the defective inlet screen. Use a cleaning agent which complies with the national/international specifications. <p>Observe the safety regulations when using cleaning agents.</p>
4	Clean the internal demister, change it as required.	Suitable cleaning agent.					x		<p>Already clean before the maintenance interval has elapsed when the noise level increases.</p> <ul style="list-style-type: none"> ■ Clean internal demister with cleaning agent ■ Replace the defective internal demister ■ Dispose of the defective internal demister as special waste. <p>Cleaning agent according to national/international specifications.</p> <p>Observe the safety regulations when using cleaning agents.</p>
5	Check the edges of the teeth on the coupling element for any damages, change the coupling element as required.						x		
6	Change the oil and clean the oil level glass.	Oil: DOT-4 Suitable cleaning agent and compressed air.					x		<p>Oil change:</p> <ul style="list-style-type: none"> ■ First oil change after 100 operating hours. ■ Pump switched off and cold. <p>Exchange the oil while the pump is cold so as to avoid releasing adsorbed gases.</p> <p>Clean the oil level glass with a cleaning agent and blow it out with compressed air under a suction hood. Use cleaning agents only corresponding to the national/international specifications. Observe the safety regulations when using cleaning agents. Quantity of oil: see Technical data</p>
7	Check the fan of the pump and motor as well as the cooling fins on the motor for deposits, and clean as required.	Brush and industrial vacuum cleaner.					x		<p>Depending on the amount of dust check the pump and keep it clean.</p> <p>Caution: switch off the pump and ensure that it cannot run inadvertently (disconnect from the mains).</p>

Key to maintenance plan

VE = Maintenance before switching on the system
 VP = Maintenance before starting production
 t = Daily maintenance
 6m = Six monthly maintenance
 a = Annual maintenance
 n-a = Maintenance every n years

We recommend that you service the pump every two years covering the following:

- Cleaning
- Checking the individual components
- Exchange of all seals
- Functional check

This service should be run by the Leybold - Service.

Maintenance

5.2 Leybold Service

Whenever you send a pump to Leybold, indicate whether the pump is contaminated or is free of substances which could pose a health hazard. If it is contaminated, specify exactly which substances are involved. You must use the form we have prepared for this purpose; we will forward the form on request.

A copy of the form is printed at the end of these operating instructions:
www.leybold.com -> Documents -> Download Documents

“Declaration of contamination of vacuum equipment and components”.

Another suitable form is available from the Leybold homepage:

www.leybold.com -> Documents -> Download Documents

Connect the form at the device or lay it to the device.

This statement detailing the contamination is required to satisfy legal requirements and for the protection of our employees.

Pumps which are not accompanied by a contamination statement will be returned to the sender.

CAUTION



Use secure shipping packaging

Package the pump such that it will not suffer any damage when being shipped and so that no oil or hazardous materials can escape from the packaging.

5.3 Monitoring the Oil Level

During operation of the TRIVAC-B-DOT the oil level must always remain between marks (9/2) and (9/3) on the oil-level glass. The amount of oil must be checked and topped up as required.

Check and top up oil only after having shut down the pump first.
Please note the safety information given in Section 0.3 und 0.4.

Pumps which have not directly been delivered from Leybold, e.g. in systems, may have been filled with oils different from DOT-4. In this case a refill with DOT-4 may cause problems. Therefore check before the refill the kind of oil in the pump and fill in only suitable oil or change the oil.

When operating the TRIVAC in connection with the exhaust filter with lubricant return (ARS 40-65) the checking intervals are extended.

When using the oil float switch (LSS) remote monitoring of the lubricant is possible.

Connect the oil float switch as follows:

- 1 0 V
- 2 +24 V

With reaching the lower oil level limit the switch passes a 24V-signal, but does not switch off the pump.

5.3.1 Checking the Condition of DOT-4

If gases or liquids dissolved in the oil result in a deterioration of the ultimate pressure, the oil can be degassed by allowing the pump to run for approx. 30 min. with the intake port closed and the gas ballast valve open.

Please note the safety information given in Section 5.4.

CAUTION



5.4 Oil Change

WARNING



Pump and operating agents may be contaminated. Hazardous substances may escape from the pump and the oil. If there is the danger that the operating agent may present a hazard in any way due to decomposition of the oil, or because of the media which have been pumped, you must determine the kind of hazard and ensure that all necessary safety precautions are taken. Use gloves, face protection or a respirator, for example.

Observe Safety Informations 0.3 und 0.4.



Change the oil while the pump is cold so as to avoid releasing adsorbed gases. If releasing adsorbed gases is no problem, change the oil after the pump has been switched off and while the pump is still warm.



Risk of suffering burns

With the pump warm from operation, both pump and oil can get so hot that there is the risk of suffering burns. If required, wear gloves.

NOTICE



Check and top up oil only after having shut down the pump first.

When disposing of waste oil, observe the applicable environment protection regulations!

When changing the oil use the same type of oil which was previously in the pump. If you want to change the type of oil entirely please consult us first.

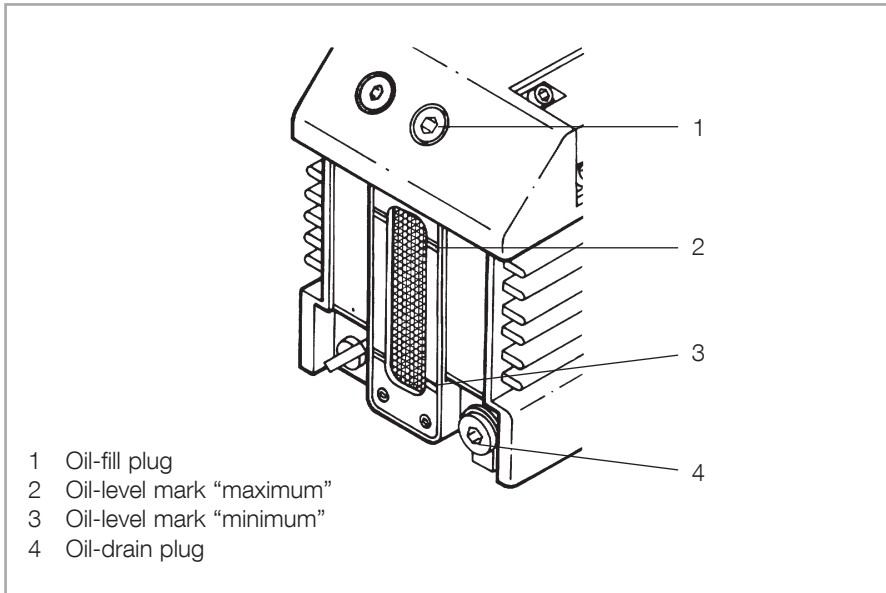

Fig. 9 Oil change

Required tool: Allen key 8 mm.

Remove the oil-drain plug (9/4) and let the used oil drain into a suitable container. When the flow of oil slows down, screw the oil-drain plug back in, briefly switch on the pump (max. 10 s) and then switch it off again. Remove the oil-drain plug once more and drain out the remaining oil.

Screw the oil-drain plug back in (check the gasket and reinstall a new one if necessary).

Remove the oil-fill plug (9/1) and fill in fresh oil.

Screw the oil-fill plug (9/1) back in.

The tightening torque for the bolts (9/1) and (9/4) has been specified at 10 Nm.

When an exhaust filter with lubricant return has been installed on the pump please also exchange the oil there.

We can only guarantee that the pump operates as specified by the technical data if the lubricants recommended by us are used.

NOTICE



5.5 Cleaning the Inlet Screen

A wire-mesh sieve is located in the intake port of the pump to act as a dirt trap for foreign objects. It should be kept clean to avoid a reduction of the pumping speed.

For this purpose, remove the dirt trap (2/2) from the intake port and rinse it in a suitable vessel with solvent. Then thoroughly dry it with compressed air.

If the dirt trap is defective, replace it with a new one.

NOTICE



The cleaning intervals depend on the application. If the pump is exposed to large amounts of abrasive materials, a dust filter should be fitted into the intake line.

5.6 Removing and Fitting the Internal Demister

Required tools: Allen keys size 5, 6 and 8

Required spare parts:

Gasket for oil case (10/7) For material No., see spare parts list

Internal demister (10/3) For material No., see spare parts list

The internal demister is spring-mounted in a frame. When it is clogged, it rises periodically to reduce the pressure difference created. The resultant noise at high intake pressures indicates that the internal demister is dirty.

Periodically clean or replace the internal demister; the maintenance interval depends on the application. Use a suitable solvent for cleaning.

Shutdown the pump and drain the oil (see Chapter 5.4).

Remove the four **recessed** screws on the oil case. Don't remove the **non-recessed** screws; they hold the motor flange in place and need not be removed.

Pull the oil case forward off the pump.

Remove the gasket and spacing discs/rings.

Lift off the frame and remove the internal demister.

Clean all parts and check that they are in perfect condition; if not, replace them with new parts.

Reassemble in the reverse order.

The tightening torque for the screws has been specified at 12.5 Nm for the D 40 B and 10 Nm for the D 16/25 B.

TRIVAC D 16-25 B-DOT:

- 1 Case for the operating agent
- 2 Spring buckles
- 3 Demister
- 4 Frame for demister
- 5 Hex. socket screws (5 pcs.)
- 6 Silencing nozzle
- 7 Gasket

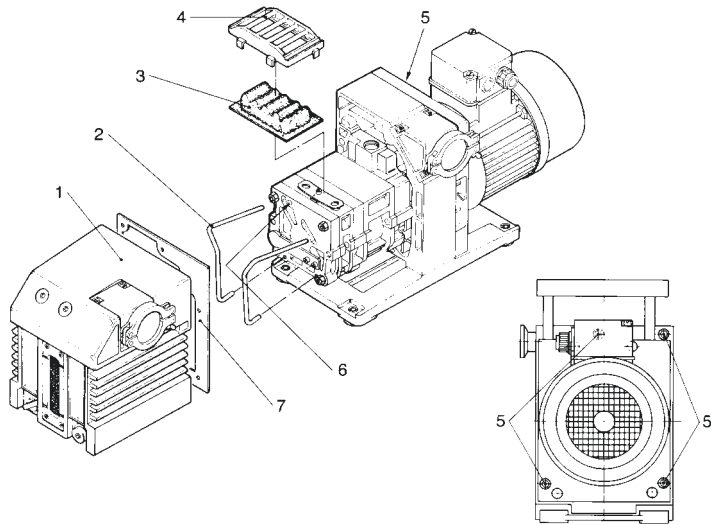

TRIVAC D 40 B-DOT:

- 1 Screw with small washer, spring, large washer and O-ring
- 2 Holding frame for demister
- 3 Demister
- 4 Case for the operating agent
- 5 Gasket
- 6 Fixing screws

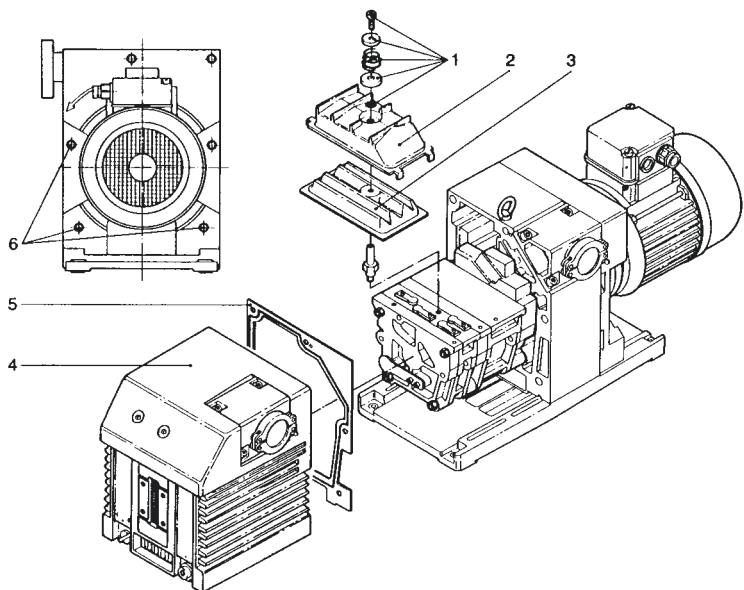

Fig. 10 Removal and fitting of the internal demister

Maintenance

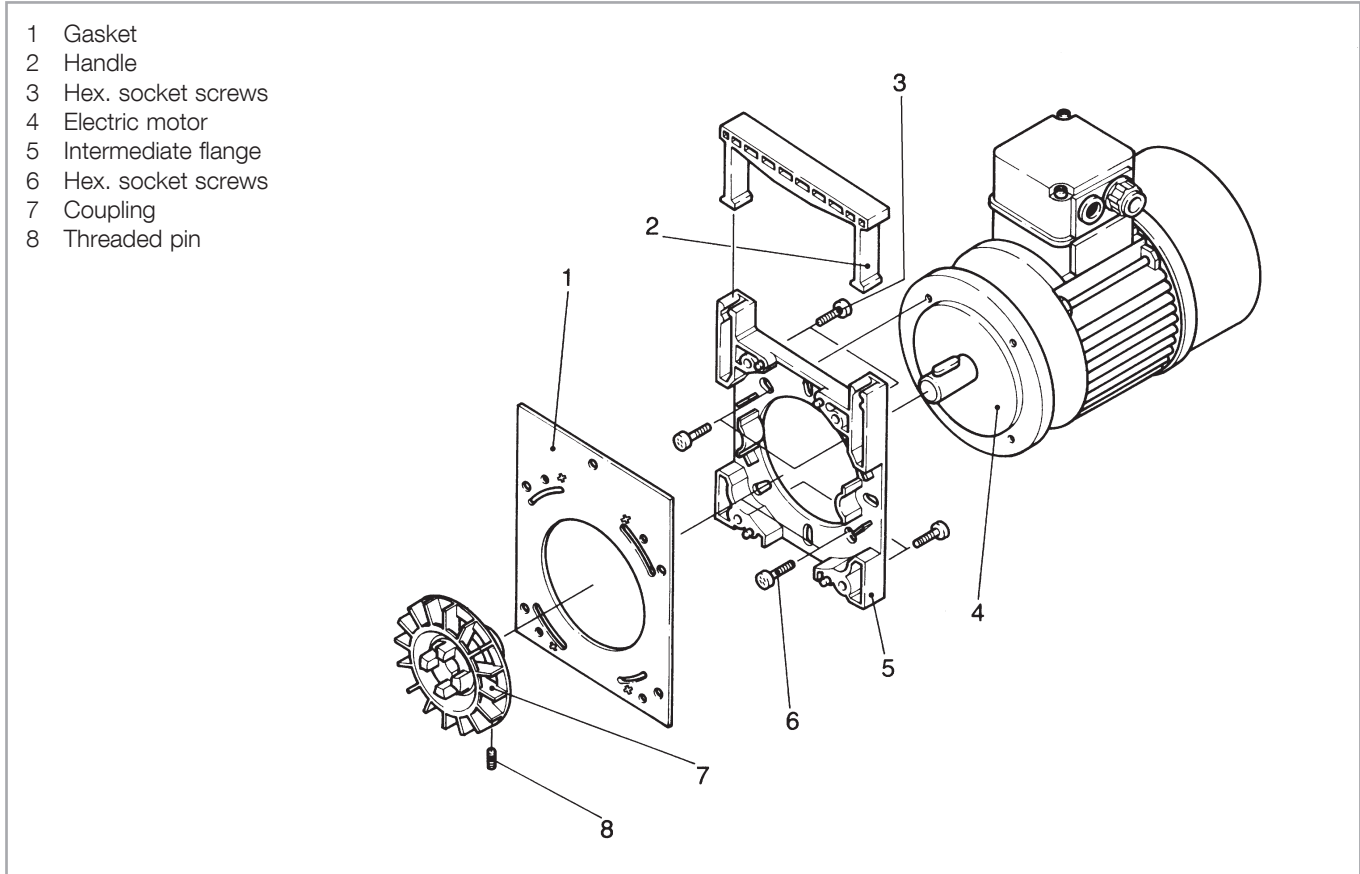

Fig. 11 Disassembly and reassembly of the electric motor

5.7 Disassembly and Reassembly of the Electric Motor

DANGER



Risk due to high voltages

Death or severe injury caused by an electric shock!

Before starting work, always disconnect the motor from the mains. Pull the mains plug. Observe Safety Informations 0.2.

Required tools:

Screwdriver 1.0 x 5.5 mm (for junction box), open-jaw wrenches 7 mm and 19 mm (for junction box), Allan keys 3 mm, 5 mm, 6 mm, possibly a puller for the coupling.

Disconnect the pump from the mains.

Unscrew the four **non-recessed** hex. socket screws (11/3).

Remove the intermediate flange (11/5) together with the electric motor (11/4).

Remove the handle (11/2).

Loosen the threaded pin (11/8) and pull the coupling (11/7) with the fan blade off the motor shaft.

Remove the gasket (11/1).

Unscrew the hex. socket screws (11/6).

Remove the electric motor (11/4).

Clean all parts and check that they are in perfect condition; if not, replace them with new parts.

Reassemble in the reverse order.

5.8 Replacing the Shaft Seal

Required tools:

Allen keys size 3, 5 and 8, flat-nose pliers, plastic hammer, shaft seal driver, possibly a puller for the coupling.

Required spare parts:

Shaft seal (12/8) For material No., see spare parts list

Bushing (12/6) For material No., see spare parts list

The TRIVAC-B-DOT has one shaft seal. Oil marks under the coupling housing are signs of a damaged shaft seal.

The shaft seal (12/8) can be replaced without removing or disassembling the pump module.

Shutdown the pump.

Drain the oil (see Chapter 5.4).

Support the motor.

Unscrew the four **non-recessed** hex. socket screws (11/3) and remove the motor (11/4) with the intermediate flange.

Remove the gasket (11/1).

Remove the coupling element (12/1).

Unscrew the hexagon socket screw (12/2) and remove the spring washer (12/3).

Pull off the coupling half (12/4).

Remove the key (12/5).

Maintenance

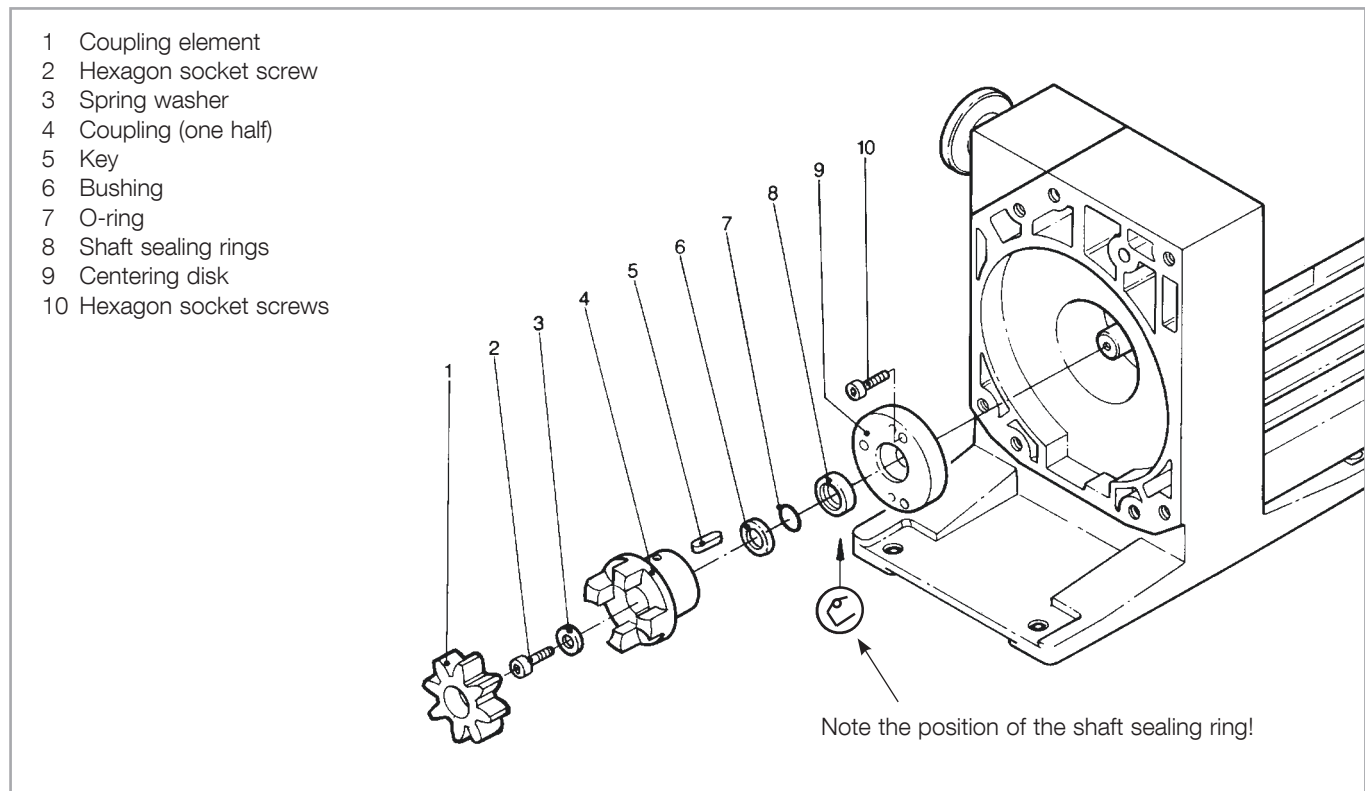

Fig. 12 Exchanging the shaft seal

Unscrew the hexagon socket screw (12/10) and remove the holding panel (12/6).

Pull the centering disk (12/9) out.

If the centering disk does not come loose, use the forcing thread into which screws (12/10) can be screwed in.

Pull the bushing (12/6) out and take the O-ring (12/7) off from the shaft.

Force the shaft seal (12/8) out of the centering disk.

Remove the O-ring (12/7).

We recommend the use of a new shaft seal and bushing for reassembly.

Before fitting the new shaft seal, moisten it slightly with a little vacuum pump oil.

Using a suitable plastic or aluminium cylinder (shaft seal driver) and a plastic hammer, force the shaft seals (12/8) carefully and without bending them into the centering disk (for position of shaft seal, see Fig. 12).

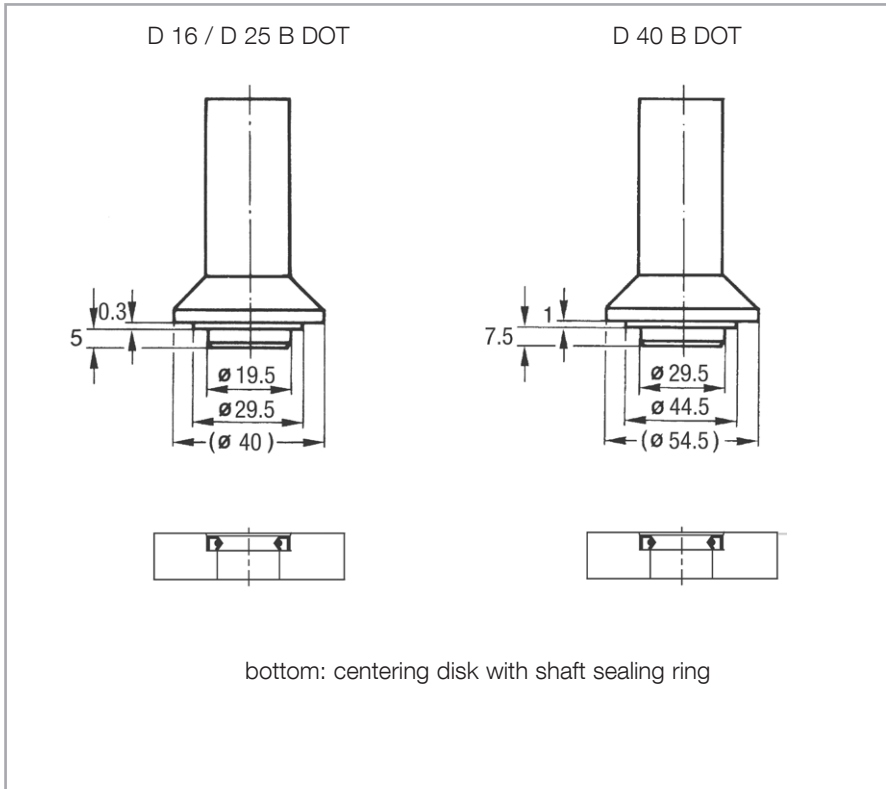

Fig. 13 Shaft sealing ring driver

The shaft seal must not be bent.

Insert the O-ring (12/8) into his groove.

Carefully push the centering disk (12/9) with the shaft seal onto the shaft and up against the end plate.

Tighten the centering disk (12/9) with bolts (12/10).

Insert the bushing (12/6) carefully at the center of the centering disk (12/9).

Insert the key (12/5).

Mount the pump-half of the coupling (12/4) on the shaft.

Install the spring washer (12/3) and tighten the screw (12/2).

Insert the coupling element (12/1) into the coupling and mount the motor (see Chapter 5.7).

Maintenance

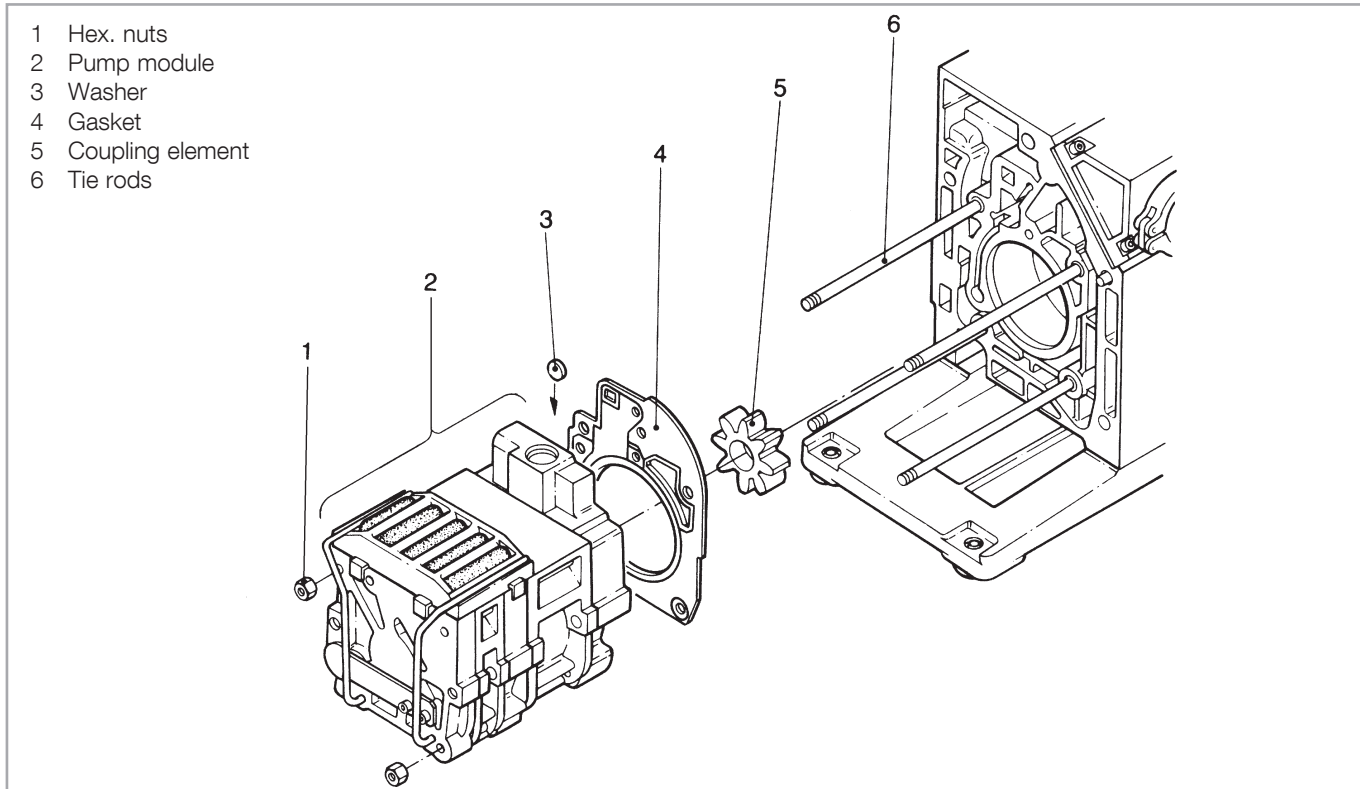

Fig. 14 Removing and remounting the pump module

5.9 Removing and Remounting the Pump Module

Required tools:

Allen keys size 3, 4, 6 and 8 mm, box wrench size 8 and 13, possibly pliers, torque wrench.

Required spare parts:

Gasket (14/4)	For material No., see spare parts list
---------------	--

5.9.1 Removing the Pump Module

Drain the oil and remove the oil case (see Chapter 5.6).

Unscrew the hex. nuts (14/1).

Pull the entire pump module (14/2) forward off the tie rods (14/6).

NOTICE



When doing so, ensure that the individual pin-fitted parts are not loosened. Further disassembly of the pump module should only be carried out by a trained service engineer.

Remove the gasket (14/4).

Remove the coupling element (14/5).

After removing the protective shipping materials, handle the new pump module with care.

Before installing a new pump module, remove the four tie rods from the new module and insert them in the old one for protection during shipment.

5.9.2 Remounting the Pump Module

When installing a new pump module, it is also advisable to use a new gasket (14/4).

Check the coupling element (14/5) for damage; if necessary, install a new one.

Use the tie rods supplied with the new pump module only if the old ones are damaged. To do so, unscrew the old tie rods with lock nuts, and screw in the new ones. With the aid of the lock nuts, tighten the tie rods. Then remove the lock nuts.

Before installing the pump module, please check whether the washer (14/3) is correctly seated in its opening.

Push the gasket (14/4) onto the tie rods (14/6), push the coupling element (14/5) onto one coupling half.

Push the entire pump module (new or repaired) onto the tie rods.

Screw on the hex. nuts (14/1) and carefully cross-tighten them (17.5 Nm for the D 40 B and 10 Nm for the D 16/25 B.)

Mount the oil case together with the gasket (see Chapter 5.6).

Fill in oil.

NOTICE



Troubleshooting

6 Troubleshooting

Fault	Possible cause	Remedy	Repair*
Pump does not start.	Wiring is malfunctioning.	Check and repair wiring.	-
	Motor protection switch incorrectly set (three-phase motors only).	Set motor protection switch properly.	3.4
	Operating voltage does not match motor.	Replace the motor.	5.7
	Motor is malfunctioning.	Replace the motor.	5.7
	Oil temperature is below 12 °C.	Heat the pump and pump oil or use a different oil.	4.3.3/5.4
	Oil is too thick.	Change the oil.	5.4
	Exhaust filter/exhaust line is clogged.	Replace the filter or clean the exhaust line.	-
	Pump is seized up (sign: pump is jammed).	Repair the pump.	Service
Pump does not reach ultimate pressure.	Measuring technique or gauge is unsuitable.	Use correct measuring technique and gauge. Measure the pressure directly at the pump's intake port.	-
	External leak ¹⁾ .	Repair the pump.	Service
	Anti-suckback valve is malfunctioning.	Repair the valve.	Service
	Exhaust valve is malfunctioning.	Repair the valve.	Service
	Oil is unsuitable.	Change the oil (degas it, if necessary).	5.4
	Vacuum lines are dirty.	Clean the vacuum lines.	-
	Pump is too small.	Check the process data, replace the pump, if necessary.	-
Pumping speed is too low.	Inlet screen in the intake port is clogged.	Clean the inlet screen. Precaution: install a dust filter in the intake line.	5.5
	Exhaust filter is clogged.	Install new filter element.	-
	Connecting lines are too narrow or too long.	Use adequately wide and short connecting lines.	3.3
After switching off the pump under vacuum, pressure in the system rises too fast.	System has a leak.	Check the system.	-
	Anti-suckback valve is malfunctioning.	Repair the valve.	Service

* Repair: Refer to the stated section in these Operating Instructions.

1) Bubble test: The warm pump with degassed oil is running without gas ballast and the intake is blanked off. The exhaust line is led into a vessel with water.

If an evenly spaced line of bubbles appears then the pump has an external leak.

Troubleshooting

Fault	Possible cause	Remedy	Repair
Pump gets hotter than usually observed.	Cooling air supply is obstructed.	Set pump up correctly.	3.1
	Ambient temperature is too high.	Set pump up correctly.	3.1/4.3.3
	Process gas is too hot.	Change the process.	-
	Oil level is too low.	Add oil.	5.3
	Oil is unsuitable.	Change the oil.	5.4
	Oil cycle is obstructed. Service	Clean or repair the oil lines and channels.	
	Exhaust filter/exhaust line is obstructed.	Replace the exhaust filter, clean the exhaust line.	-
	Exhaust valve is malfunctioning. Pump module is worn out	Repair the valve. Replace the pump module	Service 5.9
Oil in the intake line or in the vacuum vessel.	Oil comes from the vacuum system.	Check the vacuum system.	-
	Anti-suckback valve is blocked.	Clean or repair the anti-suckback valve.	Service
	Sealing surfaces of the anti-suckback valve are damaged or dirty. Service	Clean or repair intake and anti-suckback valve	
Oil is turbid.	Oil level is too high.	Drain out excess oil.	5.3
	Condensation.	Degas the oil or change the oil and clean the pump. Precaution: open the gas ballast valve or fit separator.	4.3.2/5.4
Pump is excessively noisy.	Oil level is much too low (oil level is no longer visible).	Add oil.	5.3/5.4
	Silencing nozzle is clogged.	Clean the silencing nozzle or replace it.	Service
	Intake pressure is too high.	Lower the intake pressure.	-
	Internal demister is clogged.	Clean or replace demister.	Service
	Coupling element is worn.	Install new coupling element.	-
	Vanes or bearings are damaged.	Repair pump.	Service

Disposal

7 Waste Disposal

The equipment may have been contaminated by the process or by environmental influences. In this case the equipment must be decontaminated in accordance with the relevant regulations. We offer this service at fixed prices. Further details are available on request.

WARNING



Risk of injury and environmental damage

Contaminated parts can be detrimental to health and environment. Before beginning with any work, first find out whether any parts are contaminated.

Adhere to the relevant regulations and take the necessary precautions when handling contaminated parts; For example wear gloves, face protection or breathing protection.

Separate clean components according to their materials, and dispose of these accordingly. We offer this service. Further details are available on request.

When sending us any equipment, observe the regulations given in Section "5.2 Leybold Service".

Disposal of Waste Oil

Owners of waste oil are entirely self-responsible for proper disposal of this waste.

Waste oil from vacuum pumps must not be mixed with other substances or materials.

Waste oil from vacuum pumps (Leybold oils which are based on mineral oils) which are subject to normal wear and which are contaminated due to the influence of oxygen in the air, high temperatures or mechanical wear must be disposed of through the locally available waste oil disposal system.

Waste oil from vacuum pumps which is contaminated with other substances must be marked and stored in such a way that the type of contamination is apparent. This waste must be disposed of as special waste.

European, national and regional regulations concerning waste disposal need to be observed. Waste must only be transported and disposed of by an approved waste disposal vendor.

EU Declaration of Conformity

(Translation of original Declaration of Conformity)

The manufacturer: Leybold GmbH
Bonner Strasse 498
D-50968 Köln, Germany

herewith declares that the products specified and listed below which we have placed on the market, comply with the applicable EU Directives. This declaration becomes invalid if modifications are made to the product without agreement of Leybold GmbH.

Product designation: Rotary vane pump
Type designation: TRIVAC D16B; TRIVAC D25B
Catalogue No.: 11333; 11333J; 11406; 11410; 91463-1; 140165; 1127618; 1127618J; 91275-2

The products complies to the following Directives:

Machinery Directive (2006/42/EC)

The safety objectives of the Low Voltage Directive 2014/35/EU were complied with in accordance with Appendix 1 No. 1.5.1 of Machinery Directive 2006/42/EC.

Electromagnetic Compatibility (2014/30/EU)

The following harmonized standards have been applied:

EN 1012-2:1996+A1:2009	Compressors and vacuum pumps — Safety requirements Part 2: Vacuum pumps
EN 60204-1:2006	Safety of machinery — Electrical equipment of machines Part 1: General requirements
EN 61000-6-2:2005/AC:2005	Electromagnetic compatibility (EMC) - Part 6-2: Generic standards - Immunity for industrial environments
EN 61000-6-4:2007/A1:2011	Electromagnetic compatibility (EMC) - Part 6-4: Generic standards - Emission standard for industrial environments

Documentation officer: Herbert Etges
T: +49(0)221 347 0
F: +49(0)221 347 1250
documentation@leybold.com

Cologne, September 01, 2016

Cologne, September 01, 2016



ppa. Martin Tollner
VP / Head of Product Lines



ppa. Dr. Monika Mattern-Klosson
Head of Quality & Business Process Management

EU Declaration of Conformity

(Translation of original Declaration of Conformity)

The manufacturer: Leybold GmbH
Bonner Strasse 498
D-50968 Köln, Germany

herewith declares that the products specified and listed below which we have placed on the market, comply with the applicable EU Directives. This declaration becomes invalid if modifications are made to the product without agreement of Leybold GmbH.

Product designation: Rotary vane pump
Type designation: TRIVAC D40B; TRIVAC D65B
Catalogue No.: 1128612; 1129646

The products complies to the following Directives:

Machinery Directive (2006/42/EC)

The safety objectives of the Low Voltage Directive 2014/35/EU were complied with in accordance with Appendix 1 No. 1.5.1 of Machinery Directive 2006/42/EC.

Electromagnetic Compatibility (2014/30/EU)

The following harmonized standards have been applied:

EN 1012-2:1996+A1:2009	Compressors and vacuum pumps — Safety requirements Part 2: Vacuum pumps
EN 60204-1:2006	Safety of machinery — Electrical equipment of machines Part 1: General requirements
EN 61000-6-2:2005/AC:2005	Electromagnetic compatibility (EMC) - Part 6-2: Generic standards - Immunity for industrial environments
EN 61000-6-4:2007/A1:2011	Electromagnetic compatibility (EMC) - Part 6-4: Generic standards - Emission standard for industrial environments

Documentation officer: Herbert Etges
T: +49(0)221 347 0
F: +49(0)221 347 1250
documentation@leybold.com

Cologne, September 01, 2016

Cologne, September 01, 2016



ppa. Martin Tollner
VP / Head of Product Lines



ppa. Dr. Monika Mattern-Klosson
Head of Quality & Business Process Management

Document-No.: 300303845_002_A4 09/2016

Contamination Declaration

Tips for declaring correctly



Why such a declaration?

Our customers operate in a variety of sectors and with the related applications. Furthermore, there are a large number of applications and internal uses, which in some cases are not known to us. On the other hand, the handling of different materials and substances can result in hazards for our employees.

A. Description of the device

You will make it easier for us to repair or service the device if you enter all the information required here. In particular in the case of justified claims under warranty, we can then settle the matter quickly. The details are also necessary for our own process organisation: for procuring spare parts and storing relevant components.

B. Ambient conditions

For inexpensive repairs it is important to know what the pump has been used for so far. If for example – the best-case scenario for us – the pump has not been in operation, there is no need for cleaning. For severely soiled devices or mounted parts we can then ensure consistent component quality.

C. Description of process substances

1. Which substances has our pump been in contact with?
2. Are these substances harmless?
3. If the pump has been warmed or heated, other hazards are possible.

By telling us the applications you are aware of, you make it easier for us to select the protective measures (technical, organisational, personnel) in our service centers. We can then try to prevent any risk to the health of our staff or at least reduce it to a minimum.

D. Binding signature

You complete the declaration by adding your legally binding signature. You thus assure us that you are acting in good faith and will not expose our staff to any unnecessary risk.

Hazards due to chemicals

The relevant legislation has divided chemicals into various categories of risk, with different symbols for different hazardous substances (see above). For continued use it is important to indicate known hazards, so as to avert injury to repair staff when they open or later repair the pump. This can be crucial if you are going to send us a soiled pump. Airlines for instance refuse to transport devices in case of inflammable gases or adhesion of toxic substances.

Important note for transport

For the pump to be transported safely it must be free of residues, properly sealed and well packed. Reusable packaging materials are available for the purpose. This can be crucial if you are going to send us a soiled pump. Airlines for instance refuse to transport devices in case of inflammable gases or adhesion of toxic substances.

Important note for returns

In order to obtain an appraisal of the general conditions, please complete and add the cover note on the outside in fully legible form.

Other useful hints

Please note that your employees must in certain cases use personal protective equipment when they are packing or handling our pumps. A carry-over or dispersion of hazardous substances or oils is dangerous, and it is costly to remove them.

If your staff injure themselves when using or handling your pump, or if there is the possibility of a „near miss“ accident, please let us know. We too are concerned to reduce accidents and develop means of improvement.

Many thanks for your understanding.

Declaration of Contamination of Compressors, Vacuum Pumps and Components

The repair and / or servicing of compressors, vacuum pumps and components will be carried out only if a correctly completed declaration has been submitted. Non-completion will result in delay. The manufacturer can refuse to accept any equipment without a declaration.

A separate declaration has to be completed for each single component.

This declaration may be completed and signed only by authorized and qualified staff.

Customer/Dep./Institute : _____ Address : _____ _____ Person to contact: _____ Phone : _____ Fax: _____ End user: _____	Reason for return: <input checked="" type="checkbox"/> applicable please mark Repair: <input type="checkbox"/> chargeable <input type="checkbox"/> warranty Exchange: <input type="checkbox"/> chargeable <input type="checkbox"/> warranty <input type="checkbox"/> Exchange already arranged / received Return only: <input type="checkbox"/> rent <input type="checkbox"/> loan <input type="checkbox"/> for credit Calibration: <input type="checkbox"/> DKD <input type="checkbox"/> Factory-calibr. <input type="checkbox"/> Quality test certificate DIN 55350-18-4.2.1
--	--

A. Description of the Leybold product:	Failure description: _____
Material description : _____	_____
Catalog number: _____	Additional parts: _____
Serial number: _____	Application-Tool: _____
Type of oil (ForeVacuum-Pumps) : _____	Application- Process: _____

B. Condition of the equipment	No ¹⁾	Yes	No		Contamination :	No ¹⁾	Yes
1. Has the equipment been used	<input type="checkbox"/>	<input type="checkbox"/>	<input type="checkbox"/>	→	toxic	<input type="checkbox"/>	<input type="checkbox"/>
2. Drained (Product/service fluid)	↓	<input type="checkbox"/>	<input type="checkbox"/>		corrosive	<input type="checkbox"/>	<input type="checkbox"/>
3. All openings sealed airtight	↓	<input type="checkbox"/>	<input type="checkbox"/>		flammable	<input type="checkbox"/>	<input type="checkbox"/>
4. Purged	↓	<input type="checkbox"/>	<input type="checkbox"/>		explosive ²⁾	<input type="checkbox"/>	<input type="checkbox"/>
If yes, which cleaning agent					radioactive ²⁾	<input type="checkbox"/>	<input type="checkbox"/>
and which method of cleaning					microbiological ²⁾	<input type="checkbox"/>	<input type="checkbox"/>
¹⁾ If answered with "No", go to D. ←					other harmful substances	<input type="checkbox"/>	<input type="checkbox"/>

C. Description of processed substances (Please fill in absolutely)																																
1. What substances have come into contact with the equipment ? Trade name and / or chemical term of service fluids and substances processed, properties of the substances According to safety data sheet (e.g. toxic, inflammable, corrosive, radioactive)																																
<table border="1" style="width:100%; border-collapse: collapse;"> <tr> <td style="width:5%; text-align: center;">X</td> <td style="width:30%;">Tradename:</td> <td style="width:65%;">Chemical name:</td> </tr> <tr><td></td><td>a)</td><td></td></tr> <tr><td></td><td>b)</td><td></td></tr> <tr><td></td><td>c)</td><td></td></tr> <tr><td></td><td>d)</td><td></td></tr> </table>	X	Tradename:	Chemical name:		a)			b)			c)			d)		<div style="text-align: right; margin-bottom: 10px;">↓</div> <table style="width:100%;"> <tr> <td style="width:40%;"></td> <td style="width:10%; text-align: center;">No</td> <td style="width:10%; text-align: center;">Yes</td> <td style="width:40%;"></td> </tr> <tr> <td>2. Are these substances harmful ?</td> <td style="text-align: center;"><input type="checkbox"/></td> <td style="text-align: center;"><input type="checkbox"/></td> <td style="text-align: center;">←</td> </tr> <tr> <td>3. Dangerous decomposition products when heated ?</td> <td style="text-align: center;"><input type="checkbox"/></td> <td style="text-align: center;"><input type="checkbox"/></td> <td></td> </tr> <tr> <td> If yes, which ? _____</td> <td></td> <td></td> <td></td> </tr> </table>		No	Yes		2. Are these substances harmful ?	<input type="checkbox"/>	<input type="checkbox"/>	←	3. Dangerous decomposition products when heated ?	<input type="checkbox"/>	<input type="checkbox"/>		If yes, which ? _____			
X	Tradename:	Chemical name:																														
	a)																															
	b)																															
	c)																															
	d)																															
	No	Yes																														
2. Are these substances harmful ?	<input type="checkbox"/>	<input type="checkbox"/>	←																													
3. Dangerous decomposition products when heated ?	<input type="checkbox"/>	<input type="checkbox"/>																														
If yes, which ? _____																																
²⁾ Components contaminated by microbiological, explosive or radioactive products/substances will not be accepted without written evidence of decontamination.																																

D. Legally binding declaration

I / we hereby declare that the information supplied on this form is accurate and sufficient to judge any contamination level.

Name of authorized person (block letters) : _____ _____ <div style="text-align: center;">Date</div>	_____ _____ <div style="text-align: center;">signature of authorized person</div>	<div style="border: 1px dashed black; height: 80px; width: 100%;"></div> <div style="text-align: center; font-size: small;">firm stamp</div>
---	---	--

Sales and Service

Germany

Leybold GmbH

Sales, Service, Support Center (3SC)
Bonner Strasse 498
D-50968 Cologne
T: +49-(0)221-347 1234
F: +49-(0)221-347 31234
sales@leybold.com
www.leybold.com

Leybold GmbH

Sales Area North

Branch Office Berlin
Industriestrasse 10b
D-12099 Berlin
T: +49-(0)30-435 609 0
F: +49-(0)30-435 609 10
sales.bn@leybold.com

Leybold GmbH

Sales Office South

Branch Office Munich
Karl-Hammerschmidt-Strasse 34
D-85609 Aschheim-Dornach
T: +49-(0)89-357 33 9-10
F: +49-(0)89-357 33 9-33
sales.mn@leybold.com
service.mn@leybold.com

Leybold Dresden GmbH

Service Competence Center

Zur Wetterwarte 50, Haus 304
D-01109 Dresden
Service:
T: +49-(0)351-88 55 00
F: +49-(0)351-88 55 041
info.dr@leybold.com

Europe

Belgium

Leybold Nederland B.V.

Belgisch bijkantoor

Leuvensesteenweg 542-9A
B-1930 Zaventem
Sales:
T: +32-2-711 00 83
F: +32-2-720 83 38
sales.zv@leybold.com
Service:
T: +32-2-711 00 82
F: +32-2-720 83 38
service.zv@leybold.com

France

Leybold France S.A.S.

Parc du Technopolis, Bâtiment Beta
3, Avenue du Canada
F-91940 Les Ulis cedex
Sales and Service:
T: +33-1-69 82 48 00
F: +33-1-69 07 57 38
info.ctb@leybold.com
sales.ctb@leybold.com

Leybold France S.A.S.

Valence Factory
640, Rue A. Bergès
B.P. 107
F-26501 Bourg-lès-Valence Cedex
T: +33-4-75 82 33 00
F: +33-4-75 82 92 69
marketing.vc@leybold.com

Great Britain

Leybold UK LTD.

Unit 9
Silverglade Business Park
Leatherhead Road
Chessington
Surrey (London)
KT9 2QL
Sales:
T: +44-13-7273 7300
F: +44-13-7273 7301
sales.ln@leybold.com
Service:
T: +44-13-7273 7320
F: +44-13-7273 7303
service.ln@leybold.com

Italy

Leybold Italia S.r.l.

Via Trasimeno 8
I-20128 Mailand
Sales:
T: +39-02-27 22 31
F: +39-02-27 20 96 41
sales.mi@leybold.com
Service:
T: +39-02-27 22 31
F: +39-02-27 22 32 17
service.mi@leybold.com

Netherlands

Leybold Nederland B.V.

Floridadreef 102
NL-3565 AM Utrecht
Sales and Service:
T: +31-(30) 242 63 30
F: +31-(30) 242 63 31
sales.ut@leybold.com
service.ut@leybold.com

Switzerland

Leybold Schweiz AG, Pfäffikon

Churerstrasse 120
CH-8808 Pfäffikon
Warehouse and shipping address:
Riedthofstrasse 214
CH-8105 Regensdorf
Sales:
T: +41-44-308 40 50
F: +41-44-302 43 73
sales.zh@leybold.com
Service:
T: +41-44-308 40 62
F: +41-44-308 40 60
service.zh@leybold.com

Spain

Leybold Spain, S.A.

C/. Huelva, 7
E-08940 Cornellà de Llobregat
(Barcelona)
Sales:
T: +34-93-666 43 11
F: +34-93-666 43 70
sales.ba@leybold.com
Service:
T: +34-93-666 46 11
F: +34-93-685 43 70
service.ba@leybold.com

America

USA

Leybold USA Inc.

5700 Mellon Road
USA-Export, PA 15632
T: +1-724-327-5700
F: +1-724-325-3577
info.ex@leybold.com
Sales:
T: +1-724-327-5700
F: +1-724-333-1217
Service:
T: +1-724-327-5700
F: +1-724-325-3577

Brazil

Leybold do Brasil

Rod. Vice-Prefeito Hermenegildo Tonolli,
nº. 4413 - 6B
Distrito Industrial
Jundiá - SP
CEP 13.213-086
Sales and Service:
T: +55 11 3395 3180
F: +55 11 99467 5934
sales.ju@leybold.com
service.ju@leybold.com

Asia

P. R. China

Leybold (Tianjin)

International Trade Co. Ltd.

Beichen Economic
Development Area (BEDA),
No. 8 Western Shuangchen Road
Tianjin 300400
China
Sales and Service:
T: +86-22-2697 0808
F: +86-22-2697 4061
F: +86-22-2697 2017
sales.tj@leybold.com
service.tj@leybold.com

India

Leybold India Pvt Ltd.

No. 82(P), 4th Phase
K.I.A.D.B. Plot
Bommasandra Industrial Area
Bangalore - 560 099
Indien
Sales and Service:
T: +91-80-2783 9925
F: +91-80-2783 9926
sales.bgl@leybold.com
service.bgl@leybold.com

Japan

Leybold Japan Co., Ltd.

Headquarters
Shin-Yokohama A.K.Bldg., 4th floor
3-23-3, Shin-Yokohama
Kohoku-ku, Yokohama-shi
Kanawaga 222-0033
Japan
Sales:
T: +81-45-471-3330
F: +81-45-471-3323
sales.yh@leybold.com

Leybold Japan Co., Ltd.

Tsukuba Technical Service Center
1959, Kami-yokoba
Tsukuba-shi, Ibaraki-shi 305-0854
Japan
Service:
T: +81-29 839 5480
F: +81-29 839 5485
service.iik@leybold.com

Malaysia

Leybold Malaysia

Leybold Singapore Pte Ltd.

No. 1 Jalan Hi-Tech 2/6
Kulim Hi-Tech Park
Kulim, Kedah Darul
Aman 09000
Malaysia
Sales and Service:
T: +604 4020 222
F: +604 4020 221
sales.ku@leybold.com
service.ku@leybold.com

South Korea

Leybold Korea Ltd.

3F. Jellzone 2 Tower
Jeongja-dong 159-4
Bundang-gu Sungnam-si
Gyeonggi-do
Bundang 463-384, Korea
Sales:
T: +82-31 785 1367
F: +82-31 785 1359
sales.bd@leybold.com
Service:
623-7, Upsilon-Dong
Cheonan-Si
Chungcheongnam-Do
Korea 330-290
T: +82-41 589 3035
F: +82-41 588 0166
service.cn@leybold.com

Singapore

Leybold Singapore Pte Ltd.

8 Commonwealth Lane #01-01
Singapore 149555
Singapore
Sales and Service:
T: +65-6303 7030
F: +65-6773 0039
sales.sg@leybold.com
service.sg@leybold.com

Taiwan

Leybold Taiwan Ltd.

No 416-1, Sec. 3
Chunghsin Rd., Chutung
Hsinchu County 310
Taiwan, R.O.C.
Sales and Service:
T: +886-3-500 1688
F: +886-3-583 3999
sales.hc@leybold.com
service.hc@leybold.com

Headquarter

Leybold GmbH

Bonner Strasse 498
D-50968 Cologne
T: +49-(0)221-347-0
F: +49-(0)221-347-1250
info@leybold.com



www.leybold.com