

SCROLLVAC plus

Scroll vacuum pump

Operating Instructions 300668736_002_C3

Part Nos.
1410xxVxx
1411xxAxx



Contents

	Page
Safety Symbols	5
0 Important safety information	6
0.1 Mechanical hazards	6
0.2 Electrical hazards	6
0.3 Thermal hazards	7
0.4 ATEX directive implications	7
0.5 Hazards caused by materials and substances	8
0.6 Noise hazard	9
0.7 Danger of pump damage	9
1 Description	11
1.1 Design and function	11
1.2 SCROLLVAC plus 1-phase pump	11
1.3 SCROLLVAC plus 3-phase pump	14
1.4 Gas ballast control	14
1.5 Materials	14
1.6 Supplied equipment	14
1.7 Technical data	15
1.8 Ordering information	17
1.9 Accessories	21
2 Transport and storage	22
2.1 Transport	22
2.2 Storage	22
3 Installation	23
3.1 Safety	23
3.2 System design considerations	23
3.3 Placement	24
3.4 Conforming use	25
3.4.1 Non-conforming use	25
3.5 Ambient conditions	25
3.6 Connect to the vacuum system	26
3.7 Electrical installation 1-phase	27
3.7.1 Connection for remote control and monitoring	27
3.7.2 Connect the logic interface to the control equipment	28
3.8 Electrical installation 3-phase	28
3.8.1 Check the direction of rotation	33
4 Operation	34
4.1 Operational modes – 1-phase pump	34
4.2 Manual operation – 1-phase pump	35
4.2.1 Start and stop	35
4.2.2 Standby	35
4.2.3 Auto run 1-phase pump	35

4.3	Interfaces – 1-phase pump	36
4.3.1	Digital I/O	36
4.3.2	Remote control and monitoring	38
4.4	Manual operation 3-phase pump	39
4.5	Use of gas ballast control – 1 and 3 phase pumps	39
4.6	Start-up procedure	40
4.7	To achieve ultimate vacuum	40
4.8	To pump condensable vapours	41
4.9	Shut down	41
4.10	Emergency stop (EMS) (3-phase pumps only)	41
5	Maintenance	42
5.1	Safety information	42
5.2	Maintenance plan	43
5.3	Inspect and clean the inlet strainer	43
5.4	Clean the external fan cover	44
5.5	Check the pump performance	44
5.6	Replace the tip-seals	44
5.7	Replace the pump bearings	45
5.8	Replace the pump controller (1-phase service indicator only)	45
5.9	Replace 3-phase electric terminal box fusing	46
5.10	Electrical safety check	46
5.11	Service indicator codes (1-phase service indicator only)	47
5.12	Resetting the hours counter 1-phase pump	47
5.13	Resetting the hours counter 3-phase pump	48
5.14	Battery replacement - 3-phase hours counter	48
5.15	Leybold service	49
6	Troubleshooting	50
6.1	Alarm indicator codes – 1-phase pump	52
7	Spare parts and accessories	53
7.1	Mounting accessories	55
7.1.1	Gas ballast adaptor blank	55
7.1.2	Gas ballast adaptor	56
7.1.3	Silencer	58
7.1.4	Mountable vibration isolators	60
7.1.5	Chemical resistance conversion kit	61
8	Waste Disposal	64
	EU Declaration of Conformity	65
	Certificates	66

Original operating instructions.

Safety Information

NOTICE



Obligation to Provide Information

Before installing and commissioning the pump, carefully read these Operating Instructions and follow the information so as to ensure optimum and safe working right from the start.

The Leybold **SCROLLVAC plus** has been designed for safe and efficient operation when used properly and in accordance with these Operating Instructions. It is the responsibility of the user to carefully read and strictly observe all safety precautions described in this section and throughout the Operating Instructions. Moreover, observe the information in all additionally supplied Operating Instructions for switches or valves, for example. The pump must only be operated in the proper condition and under the conditions described in the Operating Instructions. It must be operated and maintained by trained personnel only. Consult local, state, and national agencies regarding specific requirements and regulations. Address any further safety, operation and/or maintenance questions to our nearest office.

DANGER



DANGER indicates an imminently hazardous situation which, if not avoided, will result in death or serious injury.

WARNING



WARNING indicates a potentially hazardous situation which, if not avoided, could result in death or serious injury.

CAUTION



CAUTION indicates a potentially hazardous situation which, if not avoided, could result in minor or moderate injury.

NOTICE



NOTICE is used to notify users of installation, operation, programming or maintenance information that is important, but not hazard related.

We reserve the right to alter the design or any data given in these Operating Instructions. The illustrations are not binding.

Retain the Operating Instructions for further use.

Safety Information

Safety Symbols

The safety symbols on the products denote areas where care and attention is required.

The following safety symbols may be used on the SCROLLVAC plus 1-phase and 3-phase pump systems and throughout the product documentation.



Warning/Caution

An appropriate safety instruction should be followed or caution to a potential hazard exists.



Warning - Dangerous Voltage

Indicates hazards arising from dangerous voltages.



Warning - Hot Surfaces

Indicates that the marked item may be hot and should not be touched without taking precautions.



Protective conductor (ground)

To identify any terminal intended for connection to an external conductor for protection against electric shock in case of a fault, or the terminal of a protective earth (ground) electrode.



Warning - Heavy Object

Indicates the potential risk of physical injury and requires suitable lifting equipment to move.



Warning - Use protective equipment

Indicates that appropriate protective equipment must be used.



Warning – risk of explosion.

Indicates the potential risk of explosion.



Warning – Rotating parts

Risk of injury from rotating parts.

Safety Information

0 Important safety information

0.1 Mechanical hazards



- 1 Do not expose any part of the human body to the vacuum as this could result in injury to or death of people.
- 2 Do not operate the pump if the exhaust pipeline is restricted or blocked as the pump will not operate correctly and may be damaged.
- 3 The system has an Autorun mode which is designed to automatically start the pump system once power is applied.
- 4 Heavy object. Risk of physical injury. Use suitable lifting equipment.
- 5 If operating in Autorun mode, ensure that no unsafe situation can be created and inform the users of this mode. Ensure that mains is disconnected before opening any part of the vacuum chamber.
- 6 Ensure that any cabling and or pipe work attached to the pump are routed carefully to avoid causing a slip/trip hazard and to prevent any damage to the cable.
- 7 Install the pump in the vacuum system before connecting the pump to the power supply. This will ensure the pump cannot operate and injure people during installation.
- 8 Local legislation concerning the impact of the pump on the environment must be followed when installing and removing the pump.
- 9 Do not operate the pump with an open inlet as this may cause damage to the pump and or injury to people.
- 10 Care must be taken not to touch any rotating parts.

0.2 Electrical hazards



- 1 Do not operate the pump with any parts of the enclosures removed or damaged as there may be a risk of an electric shock.
- 2 Risk of electric shock, The electrical installation must be carried out by a suitably qualified person. Always make the electrical connections to the pump after the pump has been installed on the vacuum system.
- 3 Ensure that the electrical installation of the pumping system conforms to local, regional, and national electrical codes and safety requirements. It must be connected to an appropriately protected electrical supply and earth (ground) point.
- 4 This equipment is suitable for Installation Category II as defined in IEC 60664-1. The dry pumping system must be connected to an isolator that disconnects all current carrying conductors and can be locked out in the off position (LOTO). The isolator must be in close proximity to the equipment, within easy reach of the operator and identified as the disconnect device for the equipment.
- 5 Isolate the electrical supply before disconnecting the electrical supply cable from the dry pumping system.

- 6 Ensure that the system and electrical supply cable are suitably protected against earth (ground) faults and that the earth (ground) conductor of the electrical supply cable is longer than the phase conductors in the connector.
- 7 The power wiring to the system must be properly protected and routed away from any potential hazards.

0.3 Thermal hazards

- 1 Risk of burns. Do not touch the pump inlet or exhaust ports whilst the pump is running since the temperatures of these parts could be high enough to cause harm. Elevated temperatures could remain after the pump has stopped. Care shall be taken during final installation to ensure that access to hot surfaces are prevented by additional guarding.
- 2 Risk of burns from hot surfaces and / or damage to equipment, Do not exceed the maximum continuous inlet pressures specified in section 1.7.

CAUTION



0.4 ATEX directive implications



Pumps which carry the ATEX mark are designed to meet the requirements of Group II Category 3G in respects to ignition sources internal to the pump. This classification is in accordance with Directive 2014/34/EU.

There is no potential source of ignition within the pump during normal operation but there may be potential sources of ignition under conditions of rare or unexpected malfunction as defined in the Directive. As a result of this, it is necessary to consider the potential consequences of ignition sources occurring under rare or expected malfunction. (Ref ATEX137 1992/92/EC)

When flammable materials are present within the equipment you must:

- Not allow air to enter the equipment.
- Ensure the system is leak tight
- Use an inert gas purge (for example, nitrogen) to dilute any flammable gasses or vapours entering the pump inlet, and/or use an inert gas purge to reduce the concentration of flammable gases or vapours in the pump and in the exhaust pipeline, to less than one quarter of the gases published Lower Explosion Limits (LEL).

Do not pump pyrophoric materials, process debris could produce an ignition source on the scroll surface.

Do not locate the pump in an ATEX zoned area, the ATEX specification is not applicable for external atmospheres.

WARNING



Safety Information

When planning to pump hazardous substances with this pump, read the related chapters in the Safety Booklet and in these Operating Instructions first. You can download the Safety Booklet from the Leybold homepage.

DANGER



0.5 Hazards caused by materials and substances

- 1 The product is not suited for operation in explosion hazard areas.
- 2 Please see ATEX section for more information of internal ATEX classification.
- 3 The product in its standard version is not normally suited for pumping of:
 - combustible and explosive gases and vapours
 - radioactive and toxic gases and vapours
 - pyrophoric substances
 - extremely aggressive or corrosive media
 - dusty media
 - liquids
 - solids

Please consult Leybold first when considering operation under such conditions.

- 4 If within the system toxic substances or gases are being used, then the operator will be responsible for ensuring that the corresponding safety precautions are introduced!
 - 5 If the pump has previously pumped hazardous gases take the appropriate safety measures before opening the intake or exhaust ports. Use gloves, a breathing mask or protective clothing to avoid skin contact with toxic or highly corrosive substances. Work under a fume hood.
 - 6 Contaminated parts can be detrimental to health and environment. Before beginning with any work, first find out whether any parts are contaminated. Adhere to the relevant regulations and take the necessary precautions when handling contaminated parts.
-

0.6 Noise hazard

- 1 The noise level of the pump during ultimate pressure operation corresponds to the values stated in the technical data. In other operating modes and depending on the connected vacuum system, higher values can be expected. Make sure that suitable protection measures are taken to protect your hearing.

CAUTION



0.7 Danger of pump damage

- 1 Do not allow the ingestion of any objects (screws, welding beads, nuts, washers, pieces of wire, etc.) through the intake port of the pump.
- 2 The discharge line should be laid so that it slopes down and away from the pump so as to prevent condensed vapours from flowing into the pump.
- 3 During installation work on the intake and discharge pipe do not subject flanges to excessive loads.
- 4 Improper decommissioning of the pump may damage it. Follow the instructions given in Section 2 Transport and Storage of these Operating Instructions.

NOTICE



Description

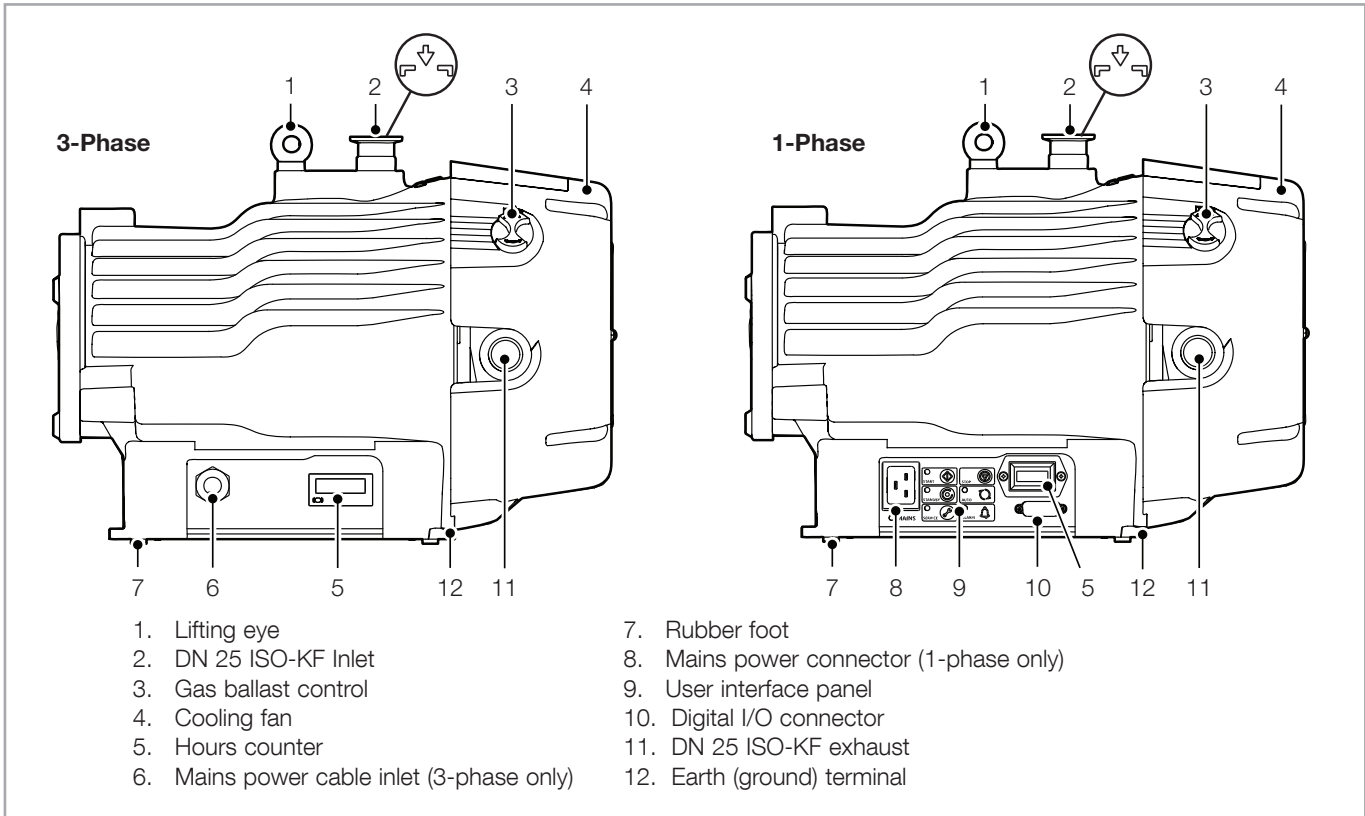

Figure 1 SCROLLVAC plus 1 and 3 phase

1 Description

1.1 Design and function

The SCROLLVAC plus 1-phase and 3-phase pumps are shown in Figure 1.

The SCROLLVAC plus pump is a truly dry vacuum pump as all the bearings, with their hydrocarbon lubricant, are isolated from the vacuum space. The SCROLLVAC plus pump is suitable for use on vapour handling processes, and may be used for some pumping applications involving corrosive substances. For information on pumping flammable gases, contact Leybold.

The body of the pump includes a fixed scroll and an orbiting scroll. The orbiting scroll is controlled by an electric motor through an eccentric crank on the motor drive shaft. The movement of the orbiting scroll, meshed with the fixed scroll, forms successive crescent shaped volumes in the pump. Gas that enters the pump through the inlet is compressed by the movement of the orbiting scroll and swept towards the centre of the fixed scroll. The compressed gas enters the exhaust port near the centre of the fixed scroll and is exhausted from the pump through the outlet.

1.2 SCROLLVAC plus 1-phase pump

Pump controller

The 1-phase integral pump controller manages the supply of current to an embedded 3-phase electric motor in accordance with operating conditions. The 1-phase pump controller nominally supplies the motor with a 60 Hz excitation frequency. The controller monitors power and temperature, and will protect the pump in the event of operation under sustained high load or under fault conditions.

The controller provides the user interface. The pump may be operated in these modes:

- Manually, using the buttons on the interface panel. Refer to Figures 2 and 13.
- Remotely via the 15-pin D-SUB digital I/O connector.

Logic interface

The pump controller can be operated via the 15-pin D-SUB digital I/O connector. The signals on the logic interface are of the following types:

- Control inputs: these are switch-type signals that are used to control the pump
- Status outputs: these outputs identify the status of the system.

Description

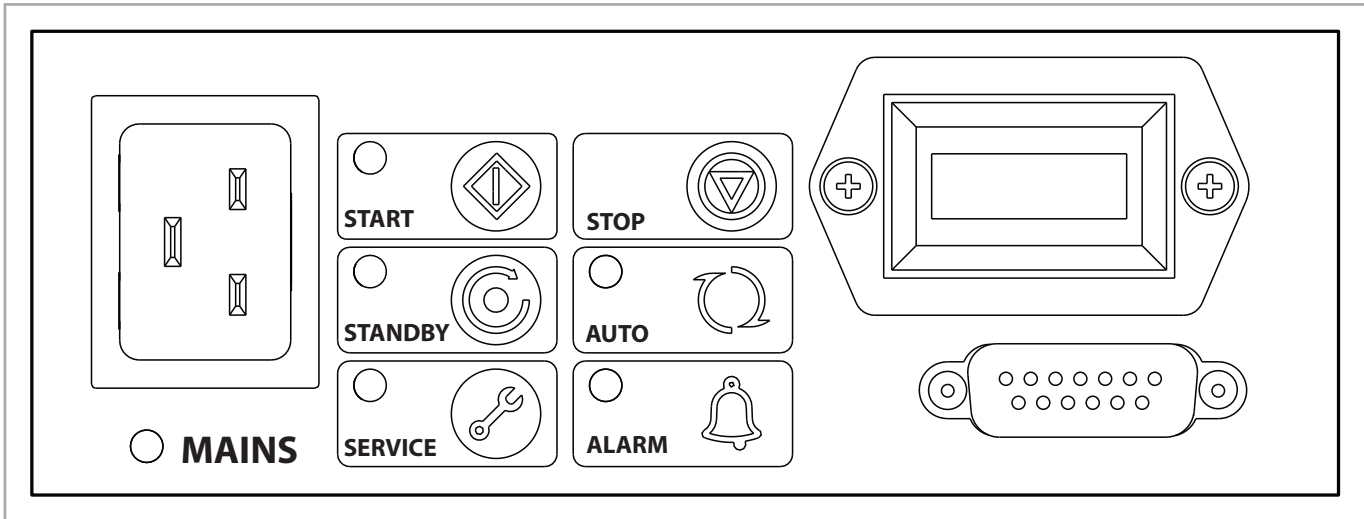

Figure 2 - 1-Phase pump user interface panel

OPERATION	SELECT	STATUS	SECTION
Apply power	MAINS POWER	The pump will remain stopped (factory default). The POWER INDICATOR will illuminate.	3
Start the pump	START BUTTON	The pump will accelerate up to full running speed. The RUN INDICATOR will flash while accelerating. The RUN INDICATOR will remain on when the pump reaches full speed.	4
Stop the pump	STOP BUTTON	The pump will decelerate and stop running. The RUN INDICATOR will flash while decelerating. The RUN INDICATOR will go off when the pump has stopped.	4
Select and deselect the standby speed	STANDBY MODE SELECT BUTTON	When engaged, the STANDBY INDICATOR will illuminate and the pump will run at the standby speed setting of 75% of full speed.	4
Select and deselect the Auto-run function	START or STOP BUTTON (>8 sec)	When engaged, the AUTO-RUN INDICATOR will illuminate. The pump will re-start automatically after the power has been restored.	4
To reset the service indicator	SERVICE RESET BUTTON	To reset the service indicator, press and hold the service reset button for more than 5 seconds.	5

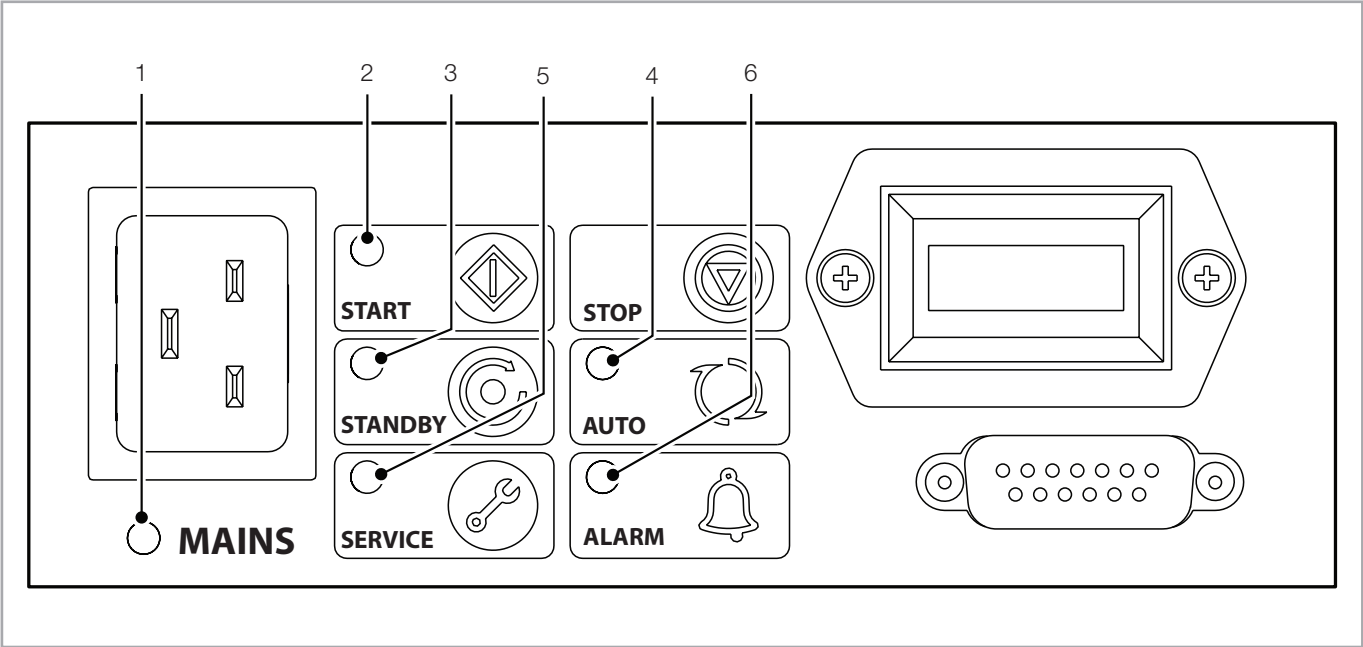

Figure 3 - 1-Phase pump LED indicators

1	Power indicator	Indicates that electrical mains supply to the pump is ON
2	Run indicator	Indicates that the pump is running.
3	Standby mode indicator	Indicates that the Standby mode has been selected.
4	Auto-run indicator	Indicates that the Auto-run mode has been selected.
5	Service indicator	Indicates that a service interval has been reached.
6	Alarm indicator	Indicates an Alarm has been triggered.

Description

1.3 SCROLLVAC plus 3-phase pump

The 3-phase direct-on-line pump includes a customer interface, electric terminal box and an embedded 3-phase electric motor. The electric terminal box provides a method for connecting and configuring the 3-phase supply to the embedded 3-phase motor. The electric terminal box also provides the user interface, comprising of:

- 3-Phase Power Input – field wiring terminals and cable gland
- Hours Counter (This contains a compact lithium cell battery which contains 1,2 DimethoxyEthane, included in the REACH Candidate List of Substances of Very High Concern, in the electrolyte.)

1.4 Gas ballast control

To pump high vapour loads, gas ballast can be delivered into the pump to prevent condensation of the vapour carried by the pumped gases.

Air can be introduced to the low vacuum stages through the gas ballast control (Figure 1, item 3). Alternatively, an inert gas such as nitrogen can be supplied through a suitable external valve and by using the appropriate adaptor, available as an accessory.

1.5 Materials

All surfaces of the pump which are exposed to the pumped gases are free from copper, zinc and cadmium. Exposed components include: anodised aluminium scrolls, aluminium housing, nickel-plated inlet and exhaust ports, PTFE composite tip-seals, various stainless steel parts and fluorocarbon elastomer seals.

Other materials of construction not exposed to vacuum include steel, copper, hydrocarbon lubricant and chemically resistant polymers.

1.6 Supplied equipment

The SCROLLVAC plus 1-phase pump is delivered ready for use, except for a mains power cable. Refer to section 1.9 for recommended mains power cables. The inlet and exhaust flanges are closed.

The SCROLLVAC plus 3-phase pump is delivered already configured for high voltage use only. High Voltage is defined as 380-415 V 50 Hz and 460 V 60 Hz. The 3-phase pump is not delivered with a power cable. The inlet and exhaust flanges are closed.

1.7 Technical data

SCROLLVAC	7 plus	10 plus	15 plus	18 plus
Peak pumping speed (m^3h^{-1}) – 1-Phase (50/60 Hz) and 3-Phase (60 Hz)	6.1	10.6	14.5	20.0
Peak pumping speed (m^3h^{-1}) – 50 Hz 3-Phase only	5.1	8.8	12.1	16.7
Maximum permitted continuous inlet pressure (mbar)*	200	200	200	50
Maximum permitted exhaust pressure (barg) †			1	
Maximum permitted gas ballast inlet pressure (barg)		0.5		
Maximum recommended chamber volume to pump down from atmospheric pressure (litres)‡	25	50	75	75
Maximum pressure rise when stopped, with no inlet or gas ballast flow (mbar)		7		
Leak tightness ($\text{mbar l}\cdot\text{s}^{-1}$)	1×10^{-6}	1×10^{-6}	1×10^{-6}	1×10^{-6}
Pump ultimate pressure (mbar), Gas ballast position 0	2×10^{-2}	9×10^{-3}	9×10^{-3}	3×10^{-2}
Pump ultimate pressure (mbar), Gas ballast position 1	5×10^{-2}	4×10^{-2}	4×10^{-2}	6×10^{-2}
Gas ballast flow (l min^{-1}), Gas ballast position 1 – 60 Hz	12	16	31	24
Maximum water vapour pumping rate (with gas ballast) (g/h)	100	140	280	220
Overall dimensions (L x W x H)		430 x 282 x 325 mm		
Maximum tilt angle		10 degrees		
Rotational speed at full load – 50 Hz		1350 rpm		
Rotational speed at full load – 60 Hz		1650 rpm		
Mass	26 kg	25 kg	26 kg	25 kg
Inlet connection		DN 25 ISO-KF		
Outlet connection		DN 25 ISO-KF		
		1-Phase	3-Phase	
Declared dual-number noise emission values in accordance with ISO 4871. Values determined in accordance with ISO3744:2010				
Measured A-weighted emission sound pressure level, L_{pA} at ultimate vacuum 1 m from the pump in free space dB(A)		55	55	
Uncertainty, K_{pA} dB(A)		2.5	2.5	
Vibration: measured at the inlet port (ISO 10816)		Class 1C...< 4.5 mms^{-1} (rms radial)		
Supply voltage, Frequency, Input current		100 – 127 Vac rms $\pm 10\%$, 50 / 60 Hz, 10 A rms	200 Vac rms $\pm 10\%$, 50 Hz, 2.4 A rms	
		200 – 240 Vac rms $\pm 10\%$, 50 / 60 Hz, 6 A rms	380 – 415 Vac rms $+6\%$ / -10% , 50 Hz, 1.5 A rms	
			200 – 230 Vac rms $\pm 10\%$, 60 Hz, 2.4 A rms	
			460 Vac rms $\pm 10\%$, 60 Hz, 1.5 A rms	

Description

	1-Phase	3-Phase
Fuse rating (Time-lag fuses must be used, as current transients can exceed the rated values.)	UK / Europe : T10AH250 for 250V ac rms US / Europe : T10AH250 for 250V ac rms	For 3-phase fuse types, please refer to section 3.8.

* These pumps are designed to pump down from atmospheric pressure, but prolonged operation at inlet pressures higher than specified may reduce bearing life.

† These pumps are intended to exhaust to atmospheric pressure. High exhaust pressure may reduce tip-seal life.

‡ Larger volumes may be pumped, but prolonged operation at inlet pressures higher than specified may reduce bearing life. The SCROLLVAC 18 plus is optimised for constant throughput and is not recommended for cyclic duty.

Note: The SCROLLVAC plus pump system is designed to operate continuously at specified, maximum, continuous operating pressures (COP), refer to section 1.7 for specific details. Operation beyond these pressure limits could result in long term reduced pumping performance, e.g. increased tip seal wear and reduced bearing life.

In the event of operating outside the specified, maximum, continuous operating pressure (COP) limits; the controller, within the 1-phase SCROLLVAC plus pump system, regulates the output power delivered to the motor. If the COP motor power is exceeded for a defined period of time, the controller will reduce the motor speed hence regulating the overall system power. This protection method, aims to preserve the life expectancy of the serviceable items, e.g. tip seals and bearings, but at the expense of pumping performance.

The 3-phase SCROLLVAC plus pump system has the same COP limits as the 1-phase SCROLLVAC plus but does not have the same power regulation functionality. The 3-phase SCROLLVAC plus pump system can run continuously beyond the recommended COP limits; however prolonged operation beyond the COP limits will result in: increased housing temperatures; increased tip seal wear and reduced bearing life.

1.8 Ordering information

Some part numbers may be available on request only.

1-ph (FU)	Standard	H-Version	C-Version
SCROLLVAC 7 plus	141007V10	141007V11	141007V12
SCROLLVAC 10 plus	141010V10	141010V11	141010V12
SCROLLVAC 15 plus	141015V10	141015V11	141015V12
SCROLLVAC 18 plus	141018V10	141018V11	141018V12

3-ph	Standard	H-Version	C-Version
SCROLLVAC 7 plus	141007V30	141007V31	141007V32
SCROLLVAC 10 plus	141010V30	141010V31	141010V32
SCROLLVAC 15 plus	141015V30	141015V31	141015V32
SCROLLVAC 18 plus	141018V30	141018V31	141018V32

In the SCROLLVAC H plus version the gas ballast control is replaced with a blank adaptor so that the gas ballast cannot be accidentally opened. This feature is useful for applications such as rare gas recirculation or gas recovery. Another advantage is improved leak tightness at this location.

The SCROLLVAC C plus version may be necessary if the pump is used on applications involving corrosive substances. For more information, contact Leybold.

The SCROLLVAC plus Standard pumps can be retrofitted to H or C versions.

Description

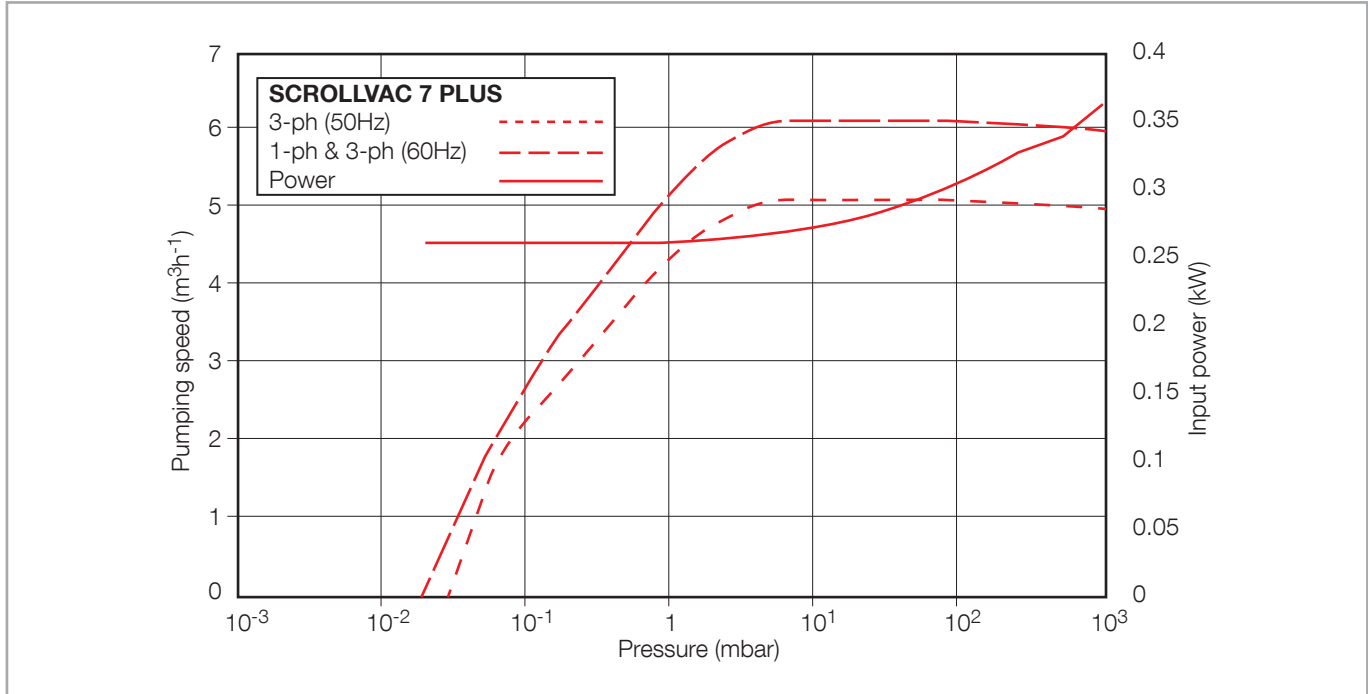

Figure 4 - SCROLLVAC 7 plus Performance characteristics

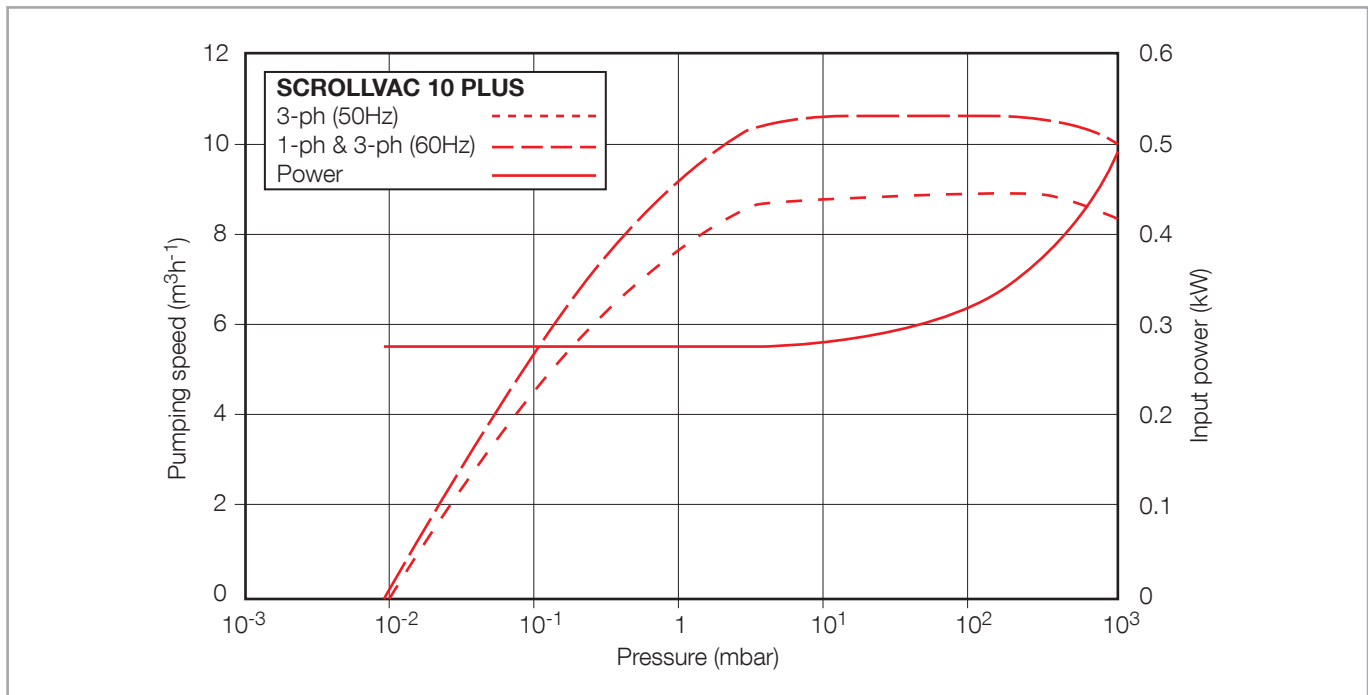

Figure 5 - SCROLLVAC 10 plus Performance characteristics

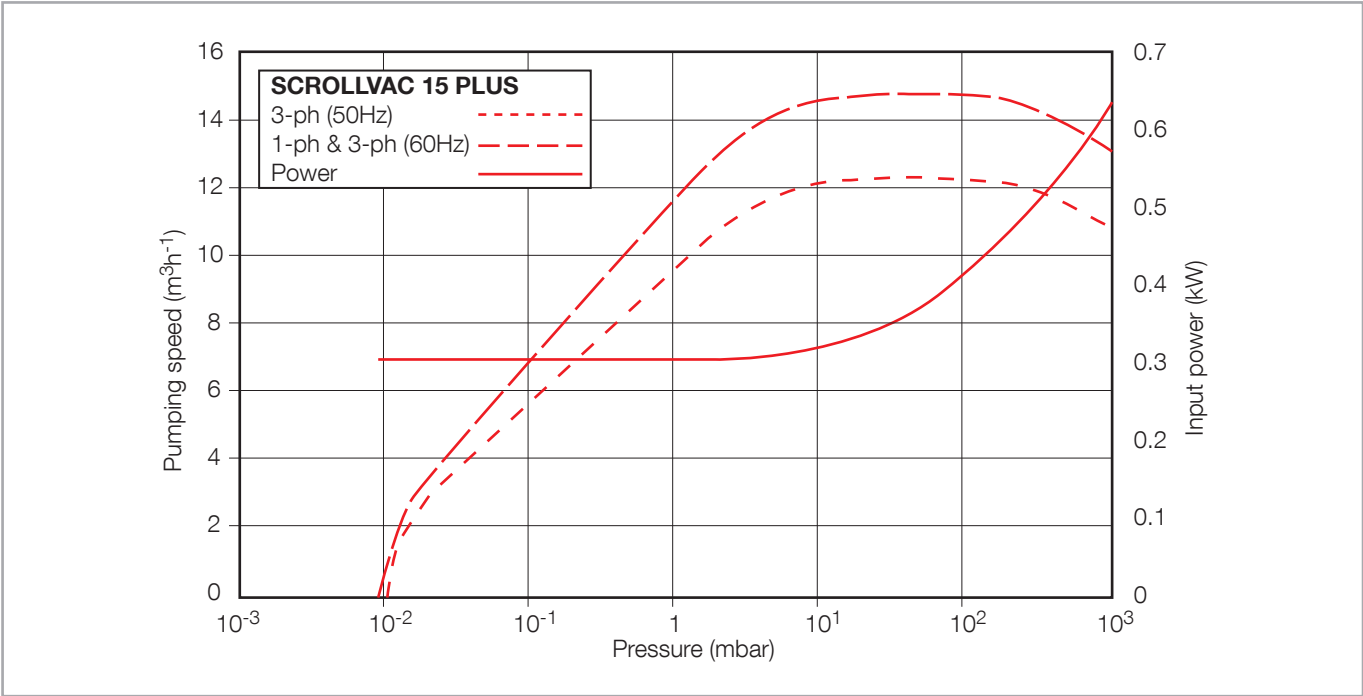

Figure 6 - SCROLLVAC 15 plus Performance characteristics

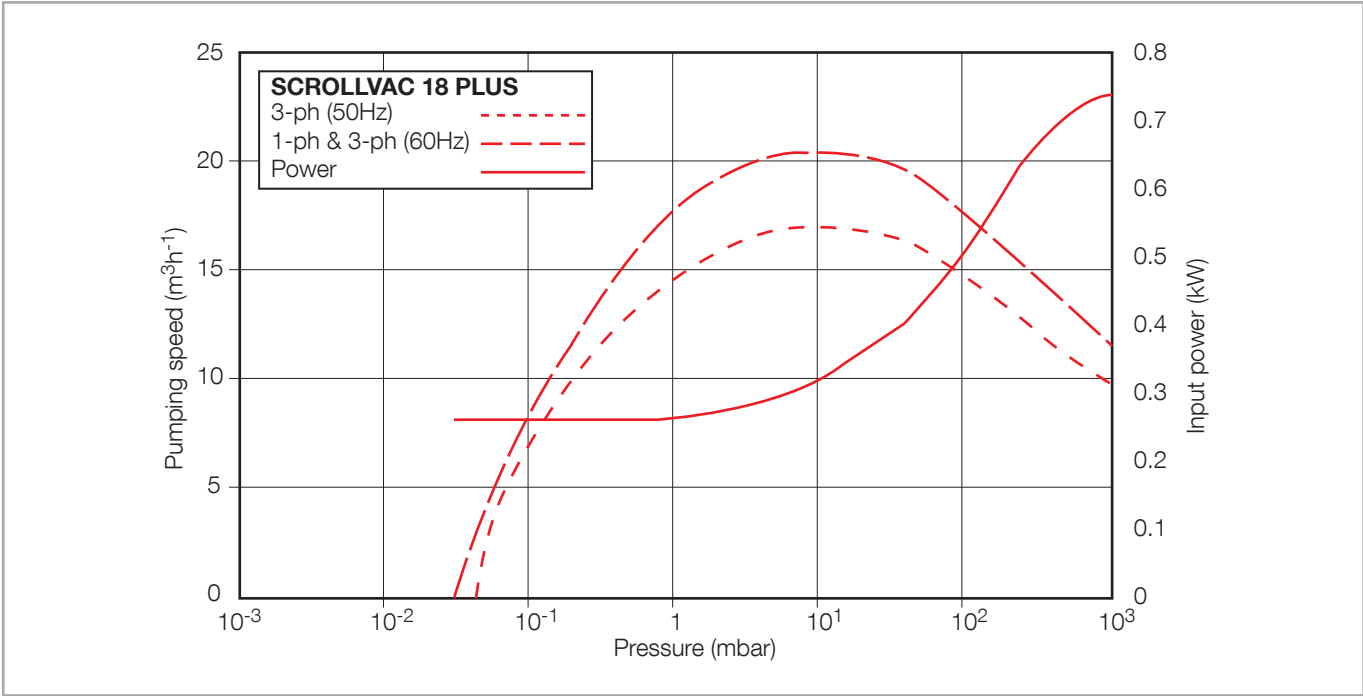

Figure 7 - SCROLLVAC 18 plus Performance characteristics

Description

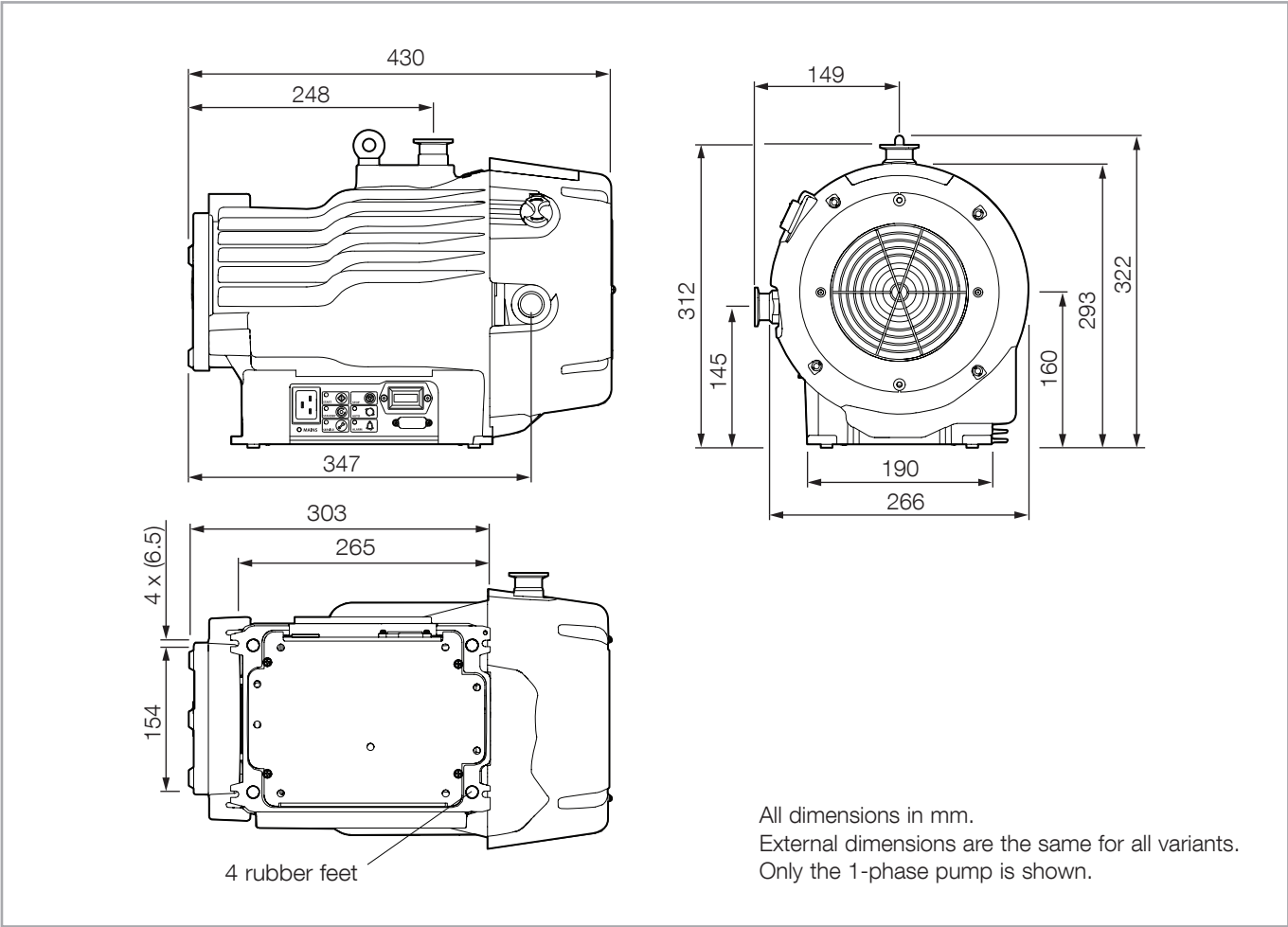

Figure 8 - Installation drawing

1.9 Accessories

Accessory	Part No.	Comment
Gas ballast adaptor blank	141100A01	The gas ballast control is replaced with a blank adaptor so that the gas ballast cannot be accidentally opened. This feature is useful for applications such as rare gas recirculation or gas recovery. Another advantage is improved leak tightness at this location.
Gas ballast adaptor (No Restriction)	141100A02	A gas ballast adaptor may be fitted in place of the gas ballast control on the pump. The adaptor allows a controlled supply of inert gas to be connected to the pump
Gas Ballast Adaptor (Fine Restriction)	141100A03	A gas ballast adaptor may be fitted in place of the gas ballast control on the pump. The adaptor allows a controlled supply of inert gas to be connected to the pump
Chemical resistance conversion kit (SC 7-15 plus)	141101A01	This adaptor kit allows a standard SCROLLVAC plus pump to be converted into an SCROLLVAC C plus version. This conversion may be necessary if the pump is used on applications involving corrosive substances. For more information, contact Leybold. Note: If returning the pump to Leybold for repair or service having been converted from a standard version to an SCROLLVAC C plus version, Leybold service must be informed, otherwise the pump will be returned back as a standard version
(SC 18 plus)	141101A02	
Vibration isolators	141102A01	Fit vibration isolators to the pump to reduce the transmitted vibration from the pump to a structure, such as a frame or a system.
Silencer	141102A02	Refer to Section 3.6 for guidance on its use.
Mains cables – 1 Phase Pump		Used to connect the SCROLLVAC plus pump to the electrical supply
Mains cable EU	161810EU	H05VV-F, 3x 1.5 mm ² , 300 V, 70 °C, length 2 m Europlug CEE7/VII (Schuko) 16A/250 V rated IEC 60320 style C19 V-Lock
Mains cable UK	161810UK	H05VV-F, 3x 1.5 mm ² , 300 V, 70 °C, length 2 m 13 A fused BS1363 UK plug IEC 60320 style C19 V-Lock
Mains cable (USA/CANADA) 200-230V	161810US	SJT 3x14 AWG, 300 V, 70 °C, length 2.5 m NEMA 6/15P plug IEC 60320 style C19 V-Lock
Mains cable (USA/CANADA) 110-120V	141103US	SJT 3x14 AWG, 300 V, 70 °C, length 2.0 m NEMA 5/15P plug IEC 60320 style C19 V-Lock

Transport and Storage

2 Transport and storage

2.1 Transport

CAUTION

Use suitable lifting equipment to move the pump. The maximum pump mass is 26 kg.

Mechanical lifting equipment should be attached to the lifting eye; loose slings should not be used.

Take care when moving the pump into position. Its mass may make it difficult to slide.

2.2 Storage

Use the following procedure to store the pump:

- 1 Shut down the pump as described in Section 4.9.
- 2 Disconnect the pump from the electrical supply.
- 3 Place and secure protective covers over the inlet and outlet ports.
- 4 Store the pump in cool, dry conditions until required for use. When required, prepare and install the pump as described in Section 3.

3 Installation

3.1 Safety

Follow all safety instructions and take note of all appropriate precautions. If the equipment is used in a manner not specified by this manual, the protection provided by the equipment may be impaired.

Ensure that the pump is suitable for the application. If in doubt, refer to the Leybold Safety Booklet in which the hazards and general safety concepts for design, operation and maintenance of vacuum systems are explained or contact Leybold for advice.

A suitably trained and supervised technician must perform the installation of the pump. Obey the safety instructions listed below, especially when connecting the pump into an existing system. Details of the specific safety precautions are given at the appropriate point in the instructions.

- Wear the appropriate safety clothing if contact with contaminated components is anticipated. Dismantle and clean contaminated components inside a fume cupboard.
- Vent and purge the vacuum system before starting installation work.
- Ensure that the installation technician is familiar with the safety procedures that relate to the products handled by the pumping system.
- Disconnect the other components in the pumping system from the electrical supply to prevent accidental operation.

3.2 System design considerations

Consider the following points when designing the pumping system:

Use a suitable valve to isolate the pump from the vacuum system if the pump needs to warm up before pumping condensable vapours or if vacuum needs to be maintained when the pump is switched off.

Avoid high levels of heat input into the pump from the process gases, otherwise the pump may overheat and cause the thermal protection system to operate.

Ensure that the exhaust pipeline cannot become blocked. If an exhaust isolation valve is installed, ensure that the pump cannot be operated with the valve closed.

Provide for a purge of inert gas when the pumping system is shut down, to dilute dangerous gases to safe concentrations.

CAUTION

Installation

3.3 Placement

Unpack and inspect

WARNING

Do not use the pump if it is damaged. Failure to do so can result in injury to people and / or damage to equipment.

Take care when unpacking the pump to avoid excessive shocks which could damage the bearings and reduce the life of the pump.

If the pump is damaged, notify the supplier and carrier immediately stating the part number and serial number of the pump together with the order number and the supplier's invoice number. Retain all packaging materials for inspection.

Open the box, remove any excess packaging as required. It is advised to retain all packaging materials for use should the pump be needed to returned for service.

If the pump is not to be used immediately, store in suitable conditions as described in section 2.

The pump is supplied with the inlets and outlet sealed to prevent entry of dust and vapour. Do not remove these seals until ready to install the pump on the vacuum system.

Position the pump

Use suitable lifting equipment attached to the lifting eyebolt (figure 1, item 1) to move the SCROLLVAC plus pump to its final operating position.

When positioning the pump ensure that access to the pump electrical supply cable or any other controls are not obstructed.

Ensure that there is a minimum of 40 mm air gap left on all sides of the pump to allow effective air circulation.

The pump must be located on a firm, level surface capable of supporting the mass of the pump.

The system should be installed away from combustible materials.

The pump can be secured to the floor by using the four holes located on each corner of the pump base. Leybold recommends using M6 (Class 12.9) bolts of suitable length (not supplied).

The pump must be level to a maximum of 3° in any direction, measured at the pump inlet.

It is the user's responsibility to carry out a risk assessment of the location and take appropriate measures to ensure that the pump is manoeuvred safely and in accordance with local and national manual handling guidelines.

3.4 Conforming use

The pump is designed to pump the following gases:

- Air
- Carbon dioxide
- Helium
- Carbon monoxide
- Nitrogen
- Argon
- Oxygen (O₂)

The pump can be used to pump water vapour. Caution must be taken to ensure that vapour does not condense inside the pump. Refer to Section 4.8 on how to prevent condensation of water vapour in the pump.

If pumping a vapour or gas not in the list above, contact Leybold for advice.

3.4.1 Non-conforming use

The product in its standard version must not be used to pump pyrophoric materials or dust. Furthermore, it is not intended to pump explosive gases continuously.

Please consult Leybold first when planning operation under such conditions.

Please see ATEX section for more information of internal ATEX classification.

The C-Version of the pump has improved corrosion resistance of critical components, allowing additional gases to be pumped, please contact Leybold to discuss your application before use.

If the pump is operated outside the specified limits, the pump housing may become hot.

WARNING



WARNING



3.5 Ambient conditions

Operating and storage conditions

Ambient temperature range (storage)	-30 °C to +70 °C
Ambient temperature range (operation)	+5 °C to +40 °C
Maximum humidity (storage in original packaging)	≤ 95% RH
Maximum humidity (operation)	90% RH

Environmental conditions

Pollution	Pollution degree 2
Installation	Installation category II
Altitude restriction	Max 2000 m*
Area of use	Indoor

* The product can be used up to an altitude of 3000m. However, the product is only certified for use up to 2000 m.

DANGER

3.6 Connect to the vacuum system

If pumping dangerous gases or vapours, connect the exhaust to a suitable treatment plant to prevent the discharge of dangerous gases and vapours to the surrounding atmosphere.

If the pump is operated with the exhaust line blocked, high pressure may be generated in the exhaust line pipework.

Before connecting the pump to the vacuum system, remove the plastic cap from the inlet and exhaust, and ensure that the inlet strainer is fitted to the pump inlet port. Use appropriate DN 25 ISO-KF vacuum fittings for connection to the system.

Take note of the following information when connecting the pump to the vacuum system:

- To minimise noise and exhaust emissions, it is recommended that the pump is connected to an exhaust line or a silencer.
- For optimum pumping speeds, ensure that the pipeline connected to the pump inlet is as short as possible and has a suitable internal diameter.
- Support the vacuum pipeline to prevent loading of the coupling joints.
- Overpressure of 3 barg may be generated in the exhaust pipework if the pump is operated with the exhaust line blocked. Connect the pump using appropriate pipework and fittings.
- If necessary, incorporate flexible bellows in the system pipelines to reduce the transmission of vibration and to prevent loading of the coupling joints. If using flexible bellows, ensure that bellows have a maximum pressure rating which is greater than the highest pressure that can be generated in the system. Leybold bellows are recommended.
- Incorporate an inlet isolation valve in the pipeline from the vacuum system to the pump to isolate the vacuum system from the pump when it is switched off and prevent suck-back of process gases and debris into the vacuum system.
- Ensure that the sealing surfaces are clean and scratch-free.

Leybold recommends using an exhaust extraction system suitable for use with all process gases that will be pumped. Ensure that the exhaust extraction system cannot become blocked or obstructed when the pump is operating.

A small amount of tip seal wear product may collect in the exhaust duct of the pump. The dust may be blown out with the initial burst of air after the pump has been vented. This is quite common and the amount of dust seen will reduce over time.

Leak test the system and seal any leaks found after pump installation.

3.7 Electrical installation 1-phase

Fuses and circuit breakers

Ensure that the electrical installation of the pump conforms to local and national safety requirements. The pump must be connected to a suitably fused and protected electrical supply with a suitable earth point. For recommended fuse ratings refer to section 1.7 and for recommended main cord sets refer to section 1.9.

Ensure that access to the pump electrical supply cable is not obstructed when locating the pump.

Route and secure cables, hoses and pipework during installation to avoid possible risk of trips.

If an overload circuit breaker is used, ensure that is a time lag type.

If using an earth leakage device, for example, a Residual Current Device (RCD), use a 30 mA (minimum) rated unit to avoid trip during start up.

The live conductor is fused inside the pump controller whilst the neutral conductor is not. An external RCD should be installed to guard against damage in the event of a short circuit between neutral and earth.

WARNING



NOTICE



Electrical supply connection

Use an IEC 60320 connector (C19) and cable that meets local electrical standards when connecting to the pump. The pump must be earthed via the earth conductor of the IEC 60320 connector.

An additional earth connection point is provided if a separate earth is required. Leybold recommends fitting a separate earth to the pump using a non-insulated braid or a separate insulated green/ yellow conductor. The conductor must be a minimum of 14 AWG. Use the M5 x 10 screw and shake proof washer located on the front of the pump housing (refer to Figure 1) to secure the earth conductor to the pump.

Disconnect the pump from the electrical supply

Isolate the Mains supply before removing the physical electrical supply connection to the pump, via the IEC 60320 cable (C19).

The 1-phase pump comes supplied with a V-lock IEC connector. This is a latching type connector and does not require a tool to disconnect the mains to the pump. In accordance with IEC 61010-1, the mains input cable must be kept to a maximum length of 3 m, there must be a suitable means to unplug the mains plug at the customer's supply source.

3.7.1 Connection for remote control and monitoring

To operate the pump using parallel control, use the 15-pin D-SUB connector on the user interface panel.

Installation

3.7.2 Connect the logic interface to the control equipment

The pump can be controlled using a hardware parallel control interface.

To control the pump using the hardware parallel interface, refer to Section 4.3 for more information.

3.8 Electrical installation 3-phase

Fuses and circuit breakers

WARNING

Ensure that the electrical installation of the 3-phase SCROLLVAC plus pump system conforms to local and national safety requirements. The electrical installation needs to be carried out by a trained electrician.

The 3-phase SCROLLVAC plus pump system is suitable for Installation Category II as defined in IEC 60664-1. The pump system must be connected to an isolator that disconnects all current carrying conductors and can be locked out in the off position (LOTO). The isolator must be in close proximity to the equipment, within easy reach of the operator and identified as the disconnect device for the equipment.

Prior to operating the 3-phase SCROLLVAC plus pump system; ensure that the pump is supplied with the correct external branch circuit protection. The 3-phase SCROLLVAC plus pump system is defined as “multi-phase, permanently connected equipment”, and it does not include internal fuse protection for the overall pump system. There is internal fusing for the low power branch circuits within the pump system, however the overall pump system must be fused externally as part of the installation procedure.

CAUTION

The table below specifies the required fusing to protect the 3-phase SCROLLVAC plus pump system in the event of a fault. In addition to this fusing, the 3-phase SCROLLVAC plus pump system must be installed with motor thermal overload protection. Failure to install the 3-phase SCROLLVAC plus pump system without the specified motor thermal overload protection could result in permanent damage to the pump if subjected to sustained overload or fault conditions, e.g. a block exhaust. Furthermore, the pump housing surface temperatures could reach levels greater than 105 °C without this protection.

Fuses and circuit breakers

Input Supply	Rated System Input Current	Recommended External Fuse Rating	Recommended Fuse Type
200 V, 50 Hz	2.4 A rms	2.5 A, 250 VAC	RK1 & RK5
200 – 230 V, 60 Hz	2.4 A rms	2.5 A, 250 VAC	
380 – 415 V, 50 Hz	1.5 A rms	1.6 A, 600 VAC	RK1, RK5 & J
460 V, 60 Hz	1.5 A rms	1.6 A, 600 VAC	

Recommended motor thermal overload protection

3-Phase SCROLLVAC plus Pump	Continuous Operating Pressure (COP)	Supply Voltage & Frequency	Max. COP Current (A, RMS)	Max. Atmospheric Current (A, RMS)	Trip Class	Motor Thermal Overload Setting (A, RMS)	Recommended Motor Thermal Overload Device
These specific protection settings apply to the 15 plus and 18 plus SCROLLVAC plus pump variants.	7 plus, 10 plus and 15 plus: 200 mbar	200 V 50 Hz	1.85	2.15	10	2.40	ABB: T16 – 3.1
		200 – 230 V 60 Hz	1.75	2.75			
These settings can also be applied to smaller 7 plus and 10 plus SCROLLVAC plus pump variants	18 plus: 50 mbar	380 – 415 V 50 Hz	1.45	1.55		1.50	ABB: T16 – 1.7
		460 V 60 Hz	1.30	1.50			

Electrical supply connection

3-phase power must be connected to the 3-phase SCROLLVAC plus pump system. The overall 3-phase cable must include 3 live wires and a protective earth (PE) ground wire.

In addition to the primary 3-phase power supply connection to the pump, the pump must also be earthed via the secondary earth connection on the rear of the pump housing using a M5 x 10 screw with a shake proof washer, refer to figure 1 for more details. The specification of this secondary earth wire must also meet the above mentioned requirements.

The 3-phase SCROLLVAC plus pump-system is not designed to be powered directly from a variable speed drive (VSD) using inverter technology. The direct use of inverter technology will lead to increased heating within the pump-system, resulting in long term damage to the pump.

If inverter technology is required; suitable in-line filtering between the inverter and the SCROLLVAC plus pump-system must be applied. The filtering must reduce the total harmonic distortion of the supply voltage to less than 5%. Please consult the inverter manufacturer for more details on the type of filter required.

In addition to the in-line filtering, the correct fuse protection is still required. Refer to tables in section 3.8.

The 3-phase SCROLLVAC plus pump system is delivered configured for high voltage use. High voltage is defined as: 380 – 415 V / 50 Hz and 460 V / 60 Hz. Ensure that the pump is correctly configured for the electrical supply voltage and frequency. If not, the embedded 3-phase motor within the pump can be damaged.

Ensure the access to the pump electrical supply cable is not obstructed when locating the pump.

If using an earth leakage current device, for example a Residual Current Device (RCD), use a 30 mA (minimum) rated unit to avoid nuisance tripping during start up.

WARNING



CAUTION



Installation

NOTICE



The pump will restart automatically when the electrical supply is restored after an interruption. If automatic restart is not desired, use electrical control equipment which must be reset manually.

Input Supply

Voltage (AC RMS)	Frequency (Hz)	Rated System Input Current (A, RMS)	Minimum Wire Gauge (4 wire: 3-phase + PE)	Recommended Wire Temperature	Recommended UL Style Number
200	50	2.5			
200 – 208	60	2.5	16 AWG / 1.5 mm ²	105 °C	UL1015
380 – 415	50	1.25			
460	60	1.25			

The recommended overall cable gauge, including 3 live wires and a PE wire with the individual wire specification defined in the table, is approximately 9.6 mm outer diameter. The M20 cable gland on the front panel of the pump is suitable for a cable diameter range: 5 – 12 mm.

Use the following procedure to connect a mains cable to the SCROLLVAC plus 3-phase pump:

- Place the pump on a flat and stable surface with the fan cowl facing upwards.

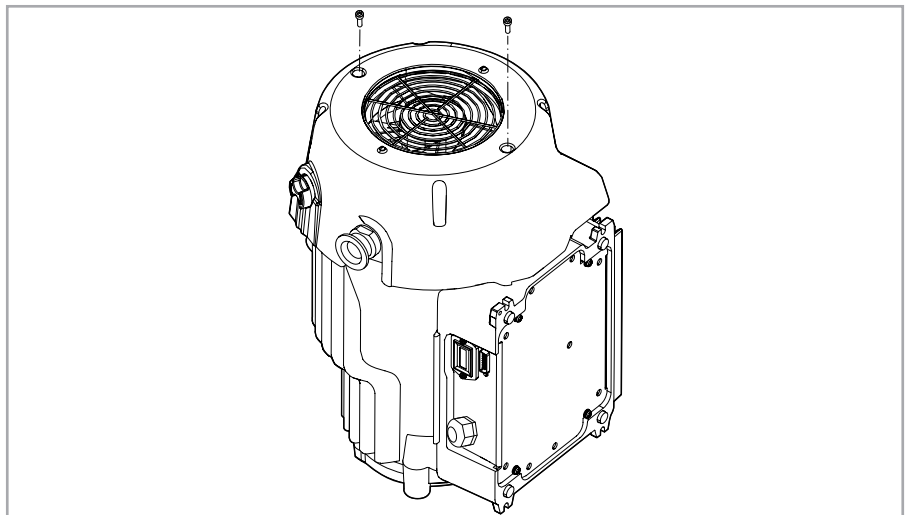

Figure 9 – 3-Phase Pump – installation setup

- Remove the fan cowl via the two screws on the top and bottom of the cowl. When the cowl is mechanically removed, disconnect the fan from the electric terminal box via the three-way connector.
- Remove the electric terminal box via the four M5 fixing screws on the under-side of the controller. Note: The cable leading from the motor will still be attached to the terminal box.

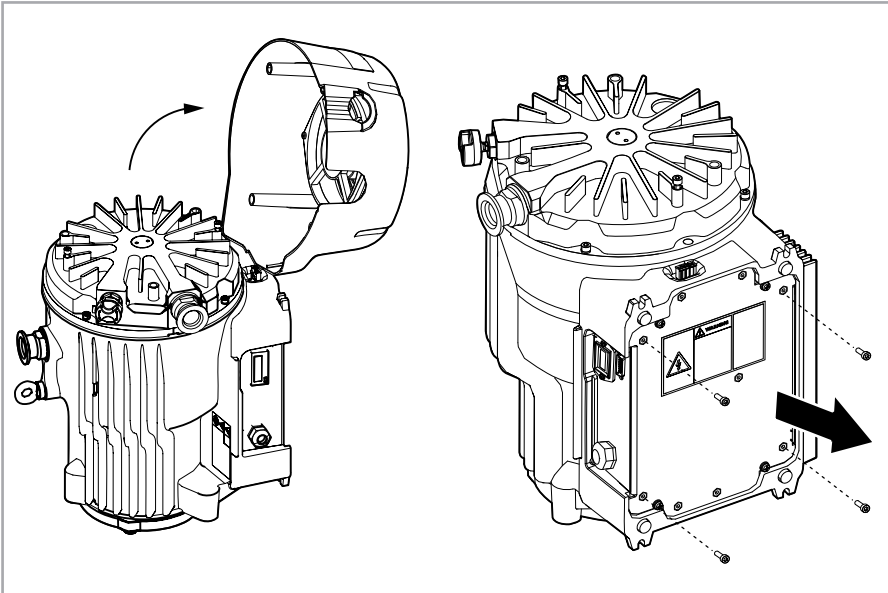

Figure 10 – 3-Phase Pump – fan cowl removal

The SCROLLVAC plus 3-phase pump will be delivered configured for high voltage operation, defined as 380-415 V 50 Hz and 460 V 60 Hz, and wired as shown in figure 11.

For low voltage operation, defined as 200 V 50 Hz and 200-230 V 60 Hz, the wiring must be configured as shown in figure 12.

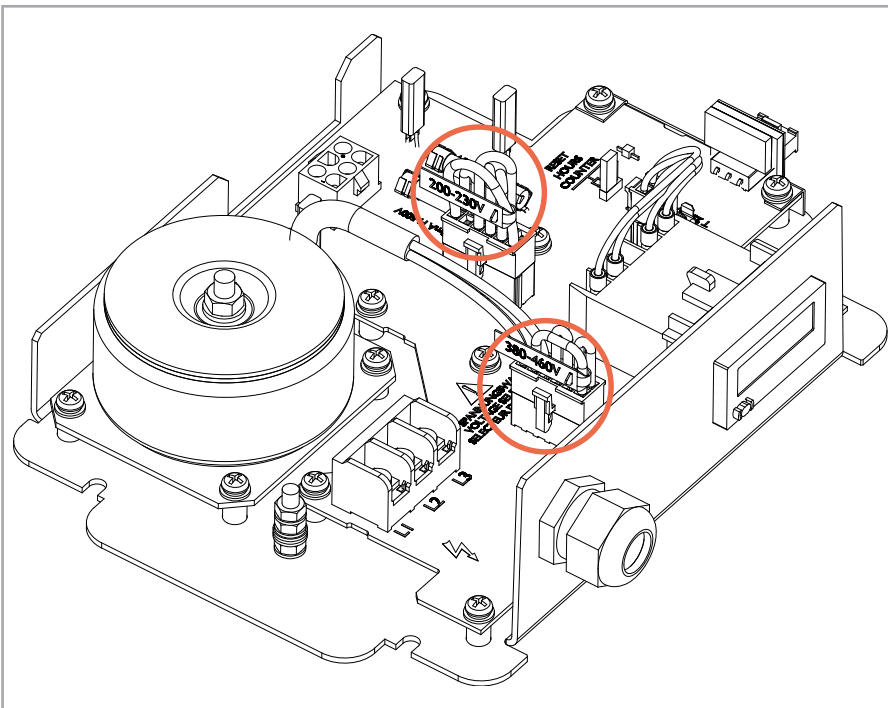

Figure 11 – 3-Phase electric terminal box – high-voltage configuration

Figure 11 shows the default high-voltage configuration. Care must be taken to insure the voltage selector connector is in the correct position to achieve high-voltage configuration.

Installation

Low-voltage configuration

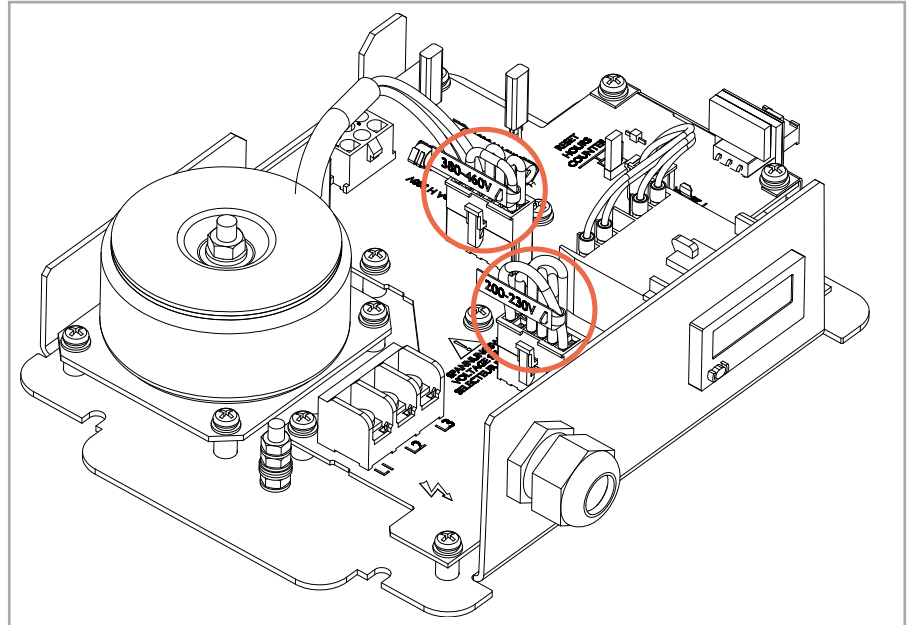

Figure 12 – 3-Phase electric terminal box – low-voltage configuration

Figure 12 shows the low-voltage configuration. Care must be taken to insure the voltage selector connector is in the correct position to achieve low-voltage configuration.

Pass the electrical cable through the cable gland (figure 1, item 6), and connect to the appropriate terminals. Tighten the earth (ground) terminal connection to a torque of 2.13 to 2.87 Nm.

The correct wiring convention for a positive electrical phase rotation (clockwise phase sequence) is as follows:

Customer's Supply	3-Phase Electric Terminal Box
L1	L1
L2	L2
L3	L3

Tighten the dome shaped nut on the cable gland until the outer sheath of the cable is firmly gripped. Using a tool, tighten to a torque of 2.5 Nm. Do not overtighten.

Refit the terminal box to the pump housing using the 4 off M5 screws torqued to 3 Nm.

Refit the fan cowl to the pump by first inserting the fan connector into the mating half in the terminal box and securing the cowl using the 2 off M5 screws torqued to 3 Nm.

Disconnect the pump from the electrical supply

Before removing the physical electrical supply connection to the pump, isolate the mains input supply.

3.8.1 Check the direction of rotation

Ensure that the motor rotates in the correct direction. If it does not, the pump and the vacuum system can become pressurized when operating the pump.

When viewing the direction of rotation care must be taken not to touch any rotating parts.

A fine dust may be emitted from the exhaust of the scroll pump during start up, particularly when the pump is new.

Avoid exposing any part of the human body to the vacuum created at the inlet port.

When checking rotation, avoid dropping foreign matter into the inlet. Dropping foreign matter into the pump can cause failure.

The direction of rotation can be checked by operating the pump with the inlet and exhaust ports open and checking that air comes out of the exhaust outlet.

Alternatively, the direction of rotation can be determined by removing the sealing grommet on the rear of the pump and observing the shaft rotation using the following procedure:

- 1 Remove the sealing grommet on the rear of the pump using a suitable tool.
- 2 With the electrical supply isolated, connect the pump electrical cable to the electrical supply.
- 3 With the pump inlet unconnected, switch on the electrical supply for a few seconds, then switch off the electrical supply again.
- 4 Check the direction of rotation of the shaft when viewed from the rear of the pump. The correct direction is clockwise. This is also indicated by an arrow on the rear of the pump. If the direction of rotation is incorrect:
 - Switch off the electrical supply immediately.
 - Isolate the pump from the electrical supply.
 - Remove the terminal box from the pump as described above and swap wires L1 and L3.
 - Refit the terminal box to the pump as described above.
- 5 Replace the grommet after the rotation has been determined.

CAUTION



Operation

WARNING



4 Operation

Do not operate the pump if the exhaust pipeline is restricted or blocked as the pump will not operate correctly and may be damaged.

CAUTION



A fine dust may be emitted from the exhaust of the scroll pump during start up, particularly when the pump is new or if new tip seals are fitted.

4.1 Operational modes – 1-phase pump

The SCROLLVAC plus pump implements two control modes:

- Manual Control Mode - using buttons on user interface panel
- Digital I/O Mode - via 15-pin D-SUB connector on user interface panel

The Control Mode is determined by the way the pump is started. Once started, the pump can only be stopped by the mode in which it was started, unless the power is cycled by isolation from the electrical supply.

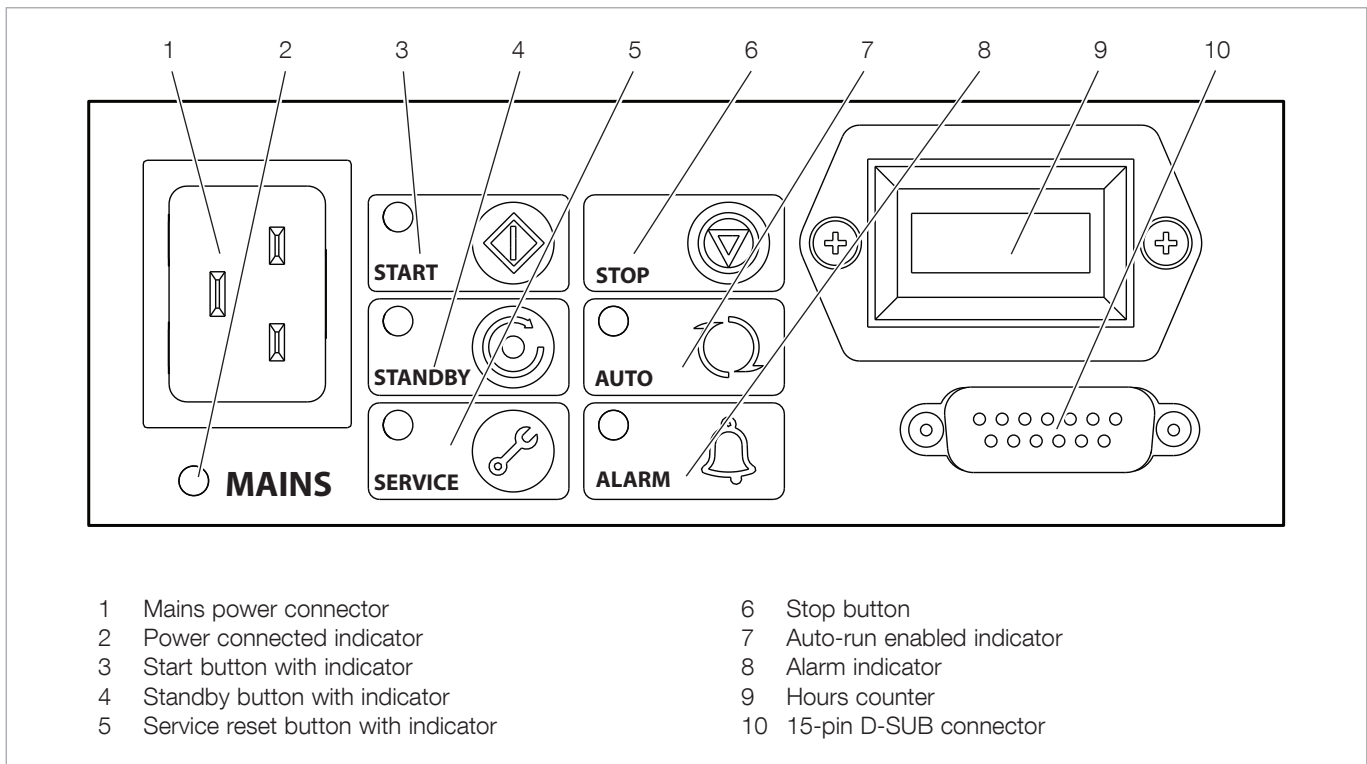

Figure 13 - User interface panel

4.2 Manual operation – 1-phase pump

The pump control functions of the user interface panel are detailed in Figure 13.

4.2.1 Start and stop

Use the buttons (Figure 13, items 3 and 6) to start and stop the pump. Note that the stop command does not isolate the pump from the electrical supply.

4.2.2 Standby

Operation at reduced speed will further improve tip seal and bearing service life. Vacuum performance will be reduced when operating at standby speed.

Press the Standby button to select standby mode. The pump will run at factory default standby speed (75% of full speed).

The Standby button must be pressed again to return to normal run speed.

4.2.3 Auto run 1-phase pump

The auto-run setting configures the pump to start at power-up without any customer intervention. This parameter is customer configurable by holding down either the START or STOP button, for more than eight seconds, will enable or disable the auto-run setting. The status of the auto-run setting is visible via the auto-run LED.

The pump can be stopped using either manual or parallel control modes whilst in auto-run.

Operation

4.3 Interfaces – 1-phase pump

4.3.1 Digital I/O

The pumps have a 15-pin D-SUB connector located on the user interface panel. A suitable connector mating half must be used (not supplied) to connect the SCROLLVAC plus pump to the customer control system.

Logic interface description

Connector (pump-side)*	15-pin D-SUB (male)
Start and remote enable:	
Enable control voltage: low (closed)	0 to 0.8 V d.c. ($I_{OUT} = 0.55$ mA nominal)
Disable control voltage: high (open)	4 to 26.4 V d.c. (Internal pull up to 6.4 V nominal)
Standby control input:	
Enable control voltage: low (closed)	0 to 0.8 V d.c. ($I_{OUT} = 0.3$ mA nominal)
Disable control voltage: high (open)	4 to 26.4 V d.c. (Internal pull up to 3.2 V nominal)

NORMAL status output:

Type	Open collector transistor plus pull up resistor.
< Normal speed (default 80%)	OFF (4.7 k pull up + diode to 12 V d.c.)
≥ Normal speed	ON (< 0.8 V d.c. sinking 10 mA)
Maximum current rating	10 mA
Maximum voltage rating	28.8 V d.c.

FAIL status output:

Type	Open collector transistor plus pull up resistor.
Fail	OFF (4.7 k pull up + diode to 12 V d.c.)
OK	ON (< 0.8 V d.c. sinking 10 mA)
Maximum current rating	10 mA
Maximum voltage rating	28.8 V d.c.

* Mating half of connector not supplied

4.3.2 Digital I/O interface connector pins

Pin Number	Signal	Use
1	Not Connected	Unused control pin.
2	0 V Control Reference	0 V reference for ALL control and status signals listed within this table.
3	START / STOP – Control Input	Connect to Pin 2 (0 V) to START the SCROLLVAC pump system.
4	STANDBY – Control Input	Connect to Pin 2 (0 V) to enable STANDBY
5	Not Connected	Unused control pin.
6	Not Connected	Unused control pin.
7	FAIL – Status Output	Logic HIGH when a fail / fault condition exists
8	0 V Control Reference	0 V reference for ALL control and status signals listed within this table.
9	Not Connected	Unused control pin.
10	Chassis / Screen	Screen
11	Not Connected	Unused control pin.
12	Chassis / Screen	Screen
13	Not Connected	Unused control pin.
14	REMOTE – Control Input	Connect to Pin 2 (0 V) to enable remote control via Parallel control mode.
15	NORMAL – Status output	Logic LOW when the pump rotational speed is at normal speed or above.

Operation

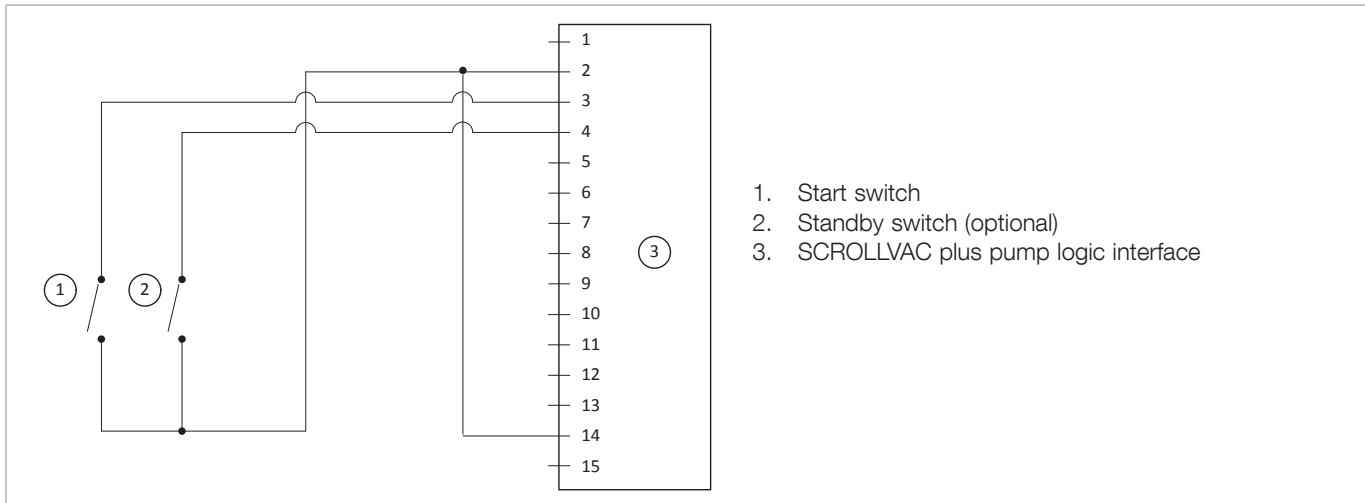

Figure 14 - Logic interface connections - parallel control

4.3.2 Remote control and monitoring

NOTICE



If using the normal and fail lines to drive the coils of d.c. relays, include a back EMF suppression diode in parallel with each relay coil to protect the pump.

Connect the control equipment to the control input pins of the logic interface mating half. The control inputs are as follows:

- Start
- Standby speed

To activate any of these control inputs, connect the relevant control input (pin 14) to the 0 V control reference.

To monitor the normal status output, connect the control equipment to the Normal status output (pin 15) and to pin 2 of the logic interface mating half. The output can be used to control other devices in the pumping system. The output can drive a low power relay of up to 24 V coil rating (up to 10 mA).

To monitor the fail status output, connect the control equipment to the fail output (pin 7) and to pin 2 of the logic interface mating half. The output can be used to control other devices in the pumping system. The output can drive a low power relay of up to 24 V coil rating (up to 10 mA).

4.4 Manual operation 3-phase pump

Do not run the pump at frequencies above 65 Hz as this could cause damage to the pump.

The 3-phase pump is a direct-on-line pump application with no speed control. The pump running speed is determined by the electrical frequency of the customer's supply, i.e. 50 or 60 Hz. See technical data section.

The pump will start as soon as power is applied.

4.5 Use of gas ballast control – 1 and 3 phase pumps

The gas ballast control can be used to optimise the performance of the scroll pump for the application. The position of the gas ballast control can be changed when the pump is either off or operating.

Use the gas ballast control to introduce air into the final stage of the pump. Use of gas ballast will reduce the condensation of vapours in the pump; the condensates would contaminate the pump.

There are only two positions, 0 and 1. The gas ballast control knob will rotate 360° in either direction at 90° intervals.

Position 0 = Gas ballast OFF. Use this setting to:

- achieve ultimate vacuum
- pump dry gases.

Position 1 = Gas ballast ON. Use this setting to:

- pump condensable vapours within the concentrations described in the technical data.
- decontaminate the pump.

NOTICE

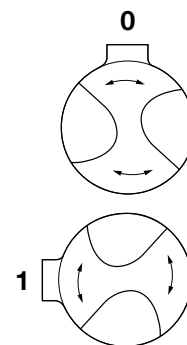

4.6 Start-up procedure

Use the procedure below to start up the **1-phase pump**:

- 1 Ensure that any vacuum system isolation valve is closed (if fitted).
- 2 With the mains supply to the pump isolated, make the electrical connection to the pump mains connector port (figure 1, item 8) with an IEC60320 connector (C19)
- 3 Check that the exhaust extraction is not restricted, and that any valves in the exhaust extraction system are open.
- 4 Apply power.
- 5 Start the pump system using the appropriate control source, that is, using the Start button in manual control mode (refer to Figure 13); the Start/Stop control input in parallel control mode or a Start command in serial control mode.
- 6 Open the vacuum system isolation valve, if fitted.

Use the following procedure to start the **3-phase pump**:

- 1 Ensure that any vacuum system isolation valve is closed (if fitted).
- 2 With the mains electrical supply isolated, make the electrical connection from the mains electrical supply outlet to the pump.
- 3 Check that the exhaust extraction is not restricted, and that any valves in the exhaust extraction system are open.
- 3 Apply power.
- 4 As the pump is direct-on-line, the pump will start as soon as power is applied.
- 5 Open the vacuum system isolation valve, if fitted.

4.7 To achieve ultimate vacuum

In order to achieve the best possible vacuum, the pump should be operated with the gas ballast control turned off. However, if the pump, or elements of the vacuum system are new or have been newly fitted, some atmospheric moisture may be present. If atmospheric moisture is present, run the pump with gas ballast on for 20 minutes before turning gas ballast off. If moisture is allowed to remain, the performance of the pump will be impaired.

4.8 To pump condensable vapours

Select gas ballast ON when there is a high proportion of condensable vapours in the process gases. This will assist the vapours to pass through the pump without condensing and keep the pump performance from degrading.

4.9 Shut down

Do not disconnect the pump from the electrical supply until the pump has stopped completely.

If the gas-ballast control is open and the pump is switched off for any reason, the pump drive shaft may rotate in the reverse direction, causing a system pressure rise. To prevent this, use a gas-ballast control valve.

The hours counter within the 3-phase SCROLLVAC plus pump system includes an embedded battery. When power is removed to the 3-phase SCROLLVAC plus pump, the hours counter will continue to display the previous “run hours” of the pump.

Use the procedure below to shut down the pump:

- 1 If shutting the pump down prior to a period of storage, remove any process gases by running on a gas ballast for at least one hour.
- 2 Close any vacuum system isolation valves to prevent suck-back into the vacuum system (where fitted).
- 3 For the **1-phase pump**; stop the pump system using the appropriate control source, that is, using the Stop button in manual control mode (refer to Figure 13); the Start/Stop control input in parallel control mode or a Stop command in serial control mode.

For the **3-phase SCROLLVAC plus pump system**; remove power by isolating the incoming 3-phase electrical supply.
- 4 Vent the pump system using the gas ballast control or the valve on the inlet.
- 5 Isolate the Mains supply.

4.10 Emergency stop (EMS) (3-phase pumps only)

The SCROLLVAC plus 3-phase pump is not fitted with an emergency stop. If an emergency stop function is required, then this product can be connected into the user's own Emergency Stop Control Circuit.

CAUTION



NOTICE



CAUTION



Maintenance

5 Maintenance

5.1 Safety information

WARNING

Obey the safety instructions in this section and take note of appropriate precautions. Failure to observe these instructions may result in injury to people and damage to equipment.

WARNING

In order to maintain the ATEX certification, all maintenance work has to be carried out in accordance with this SCROLLVAC plus instruction manual and the SCROLLVAC plus Replacement Tip Seal manual, using only genuine Leybold spare parts.

WARNING

Disconnect the pump and other components from the electrical supply to prevent accidental operation.

DANGER

The pump may be contaminated with the process chemicals that have been pumped during operation. If so, ensure that the pump is decontaminated before maintenance and adequate precautions taken to protect people from the effects of dangerous substances if contamination has occurred.

CAUTION

Allow the pump to cool for at least 3 hours before starting maintenance work.

DANGER

Do not touch or inhale the thermal breakdown products of fluorinated materials which may be present in the pump if the pump has been heated to 260 °C and above. Fluorinated materials are safe in normal use but can decompose into very dangerous substances (which may include hydrofluoric acid) if heated to 260 °C and above. The pump may have overheated if it was misused or if it was in a fire. Safety Data Sheets for fluorinated materials used in the pump are available on request; contact the supplier or Leybold.

NOTICE

External surfaces of the pump should be cleaned using a damp cloth of warm water only. Care must be taken with solvent-based cleaning fluids as they may remove important information from the product labels.

The pump is designed to require little user maintenance. Observe the following guidelines when carrying out maintenance on the pump:

- Ensure the maintenance is done by a suitably trained and supervised technician. Obey local and national safety requirements.
- Ensure the maintenance technician is familiar with the safety procedures which relate to the products processed by the pumping system.
- Check that all the required parts are available and are of the correct type before starting work.

5.2 Maintenance plan

More frequent maintenance may be required if the pump is used to pump aggressive gases or vapours, such as solvents, organic substances and acids, or if the pump is operated continuously at the higher end of its operating temperature.

Operation	Frequency (months)	Service indicator	Hours Indicator	Section reference
		1-Phase	1 & 3 Phase	
Inspect and clean the inlet strainer	12	No	8760	5.3
Inspect and clean the external fan cover if required	12	No	8760	5.4
Check the pump performance	30	Yes	21900	5.5
Replace the pump bearings	60	Yes	43800	5.7
Replace the pump controller	120	Yes	87600	5.8
Electrical safety check	60	No	43800	5.10

For service indicator codes (for 1-phase pumps only), refer to Section 5.11.

5.3 Inspect and clean the inlet strainer

Whenever the pump is disconnected from the vacuum system, or on an annual basis, Leybold recommends:

- Removing the inlet strainer from the pump inlet (refer to Figure 1) and remove any debris that may have accumulated.
- Inspecting the inlet strainer and if necessary, clean it with a cleaning solution suitable for the substances pumped. Refit the inlet strainer before reconnecting the pump to the vacuum system. Refer to Section 3.6.

Maintenance

5.4 Clean the external fan cover

If the fan cover is not kept clean, the air flow over the pump can be restricted and the pump may overheat.

1. Switch off the pump and disconnect it from the electrical supply.
2. Use a dry cloth and a soft brush to remove dirt and deposits from the fan cover.

5.5 Check the pump performance

If the service indicator for 1-phase pumps is flashing ON 1s / Off 1s or the hours counter on the 3-phase pump has reached the recommended running hours as detailed in section 5.2, then it is recommended that the performance of the pump is checked.

If after checking, the pump is no longer achieving the required performance as detailed in section 1.7, Leybold recommends carrying out a tip-seal replacement, refer to section 5.6.

If however the pump performance is still within acceptable limits, or is performing satisfactorily, the tip-seal replacement can be delayed.

If operating a preventative maintenance plan, depending upon the particular regime, a tip-seal change can be carried out at this time irrespective of the pump performance.

To reset the 1-phase service indicator, refer to Section 5.11.

5.6 Replace the tip-seals

This information is applicable to the SCROLLVAC plus replacement tip seal kit that must be fitted.

A tip-seal replacement should be carried out to maintain or restore the pumps performance. The frequency for replacing the pump tip-seals is determined by the following factors:

- The pump has reached a service interval. Refer to Sections 5.2 and 5.5.
- The pump is no longer achieving the required performance.

If the pump is no longer achieving the required performance prior to a service interval being reached, Leybold recommends first following the Troubleshooting, Section 6.

Note: There may be a running-in period after fitting your new tip-seals. The performance should improve over a period of 24 to 48 hours. If the pump performance does not improve sufficiently after the running-in period, please contact Leybold for advice.

Please see SCROLLVAC plus Replacement Tip Seal manual.

5.7 Replace the pump bearings

If the service indicator for 1-phase pumps is flashing ON 3s / Off 1s or the hours counter on the 3-phase pump has reached the recommended running hours as detailed in section 5.2, then this is an indication that a bearing replacement service interval has been reached.

Bearing wear cannot necessarily be detected under normal operating conditions. This service interval is a recommendation that a bearing replacement is required, this is especially useful if operating a preventative maintenance plan.

It is possible for an experienced technician, who is suitably trained, to perform maintenance and repair on SCROLLVAC plus pumps up to and including bearing replacement.

Note: Failure to replace the pump bearings at this time may subsequently lead to damage of the pumping mechanism.

Note: A tip-seal change and exhaust and ballast valve change should be carried out at the same time when performing a bearing replacement.

To reset the 1-phase service indicator, refer to Section 5.11.

5.8 Replace the pump controller (1-phase service indicator only)

The service indicator, (flashing ON 3s / OFF 3s) is triggered to indicate that the pump controller should be replaced. Contact Leybold for further details.

To reset the 1-phase service indicator, refer to Section 5.11.

5.9 Replace 3-phase electric terminal box fusing

The 3-phase electric terminal box includes fuse protection for the hours counter and the electric fan. In the event of either sub-component failing the internal fusing can be changed using the following procedure:

- Remove power to the 3-phase pump.
- Isolate the electrical supply.
- Remove the 3-phase electric terminal box – refer to section 3.8 for more details.
- Transformer fusing: FS1 & FS2 – T 500mA H 500V (item 1 & 2 in figure 15)
- Fan & Hours counter fusing: FS3 – T 250mA H 250V (item 3 in figure 15)

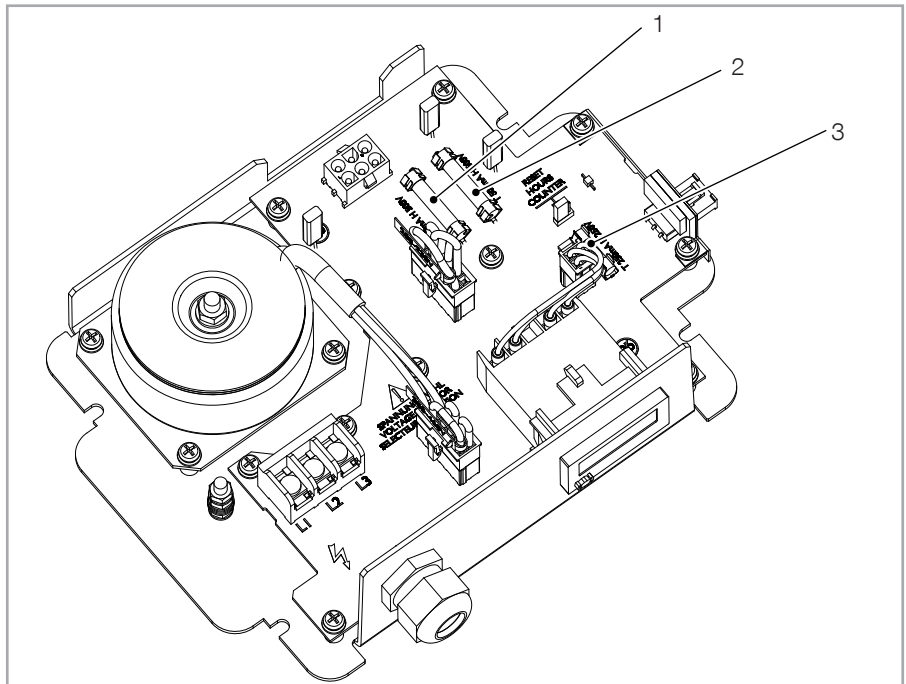

Figure 15 Fuse replacement

5.10 Electrical safety check

Test the earth continuity and the insulation resistance of the pump system in accordance with local regulations for the periodic testing of electrical equipment.

The earth continuity should be less than 0.1Ω and the DC insulation resistance greater than $1.0\text{ M}\Omega$. If the pump fails any of these tests, the supplier or Leybold must be contacted.

5.11 Service indicator codes (1-phase service indicator only)

The 1-phase SCROLLVAC plus controller incorporates a service indicator. The service indicator will flash a specific code whenever a service interval has been reached.

Service flash code	Comments	See section
ON 1s / OFF 1s	Pump performance check.	5.5
ON 3s / OFF 1s	Pump bearing service.	5.7
ON 3s / OFF 3s	Pump-Controller service.	5.8

To reset the service indicator, press and hold the service reset button for more than 5 seconds.

Note: Resetting the pump bearing service indicator will also reset the performance check timer, that is, both counters will be set to zero.

Note: Resetting the service indicator will reset the service timer back to zero.

5.12 Resetting the hours counter 1-phase pump

We recommend not to reset the hours counter but leave it running in order to keep track of the pump history. If a hours counter reset is required the following steps need to be carried out:

- 1 Remove power to 1-phase pump and wait two minutes for the residual voltage to discharge; then take the hours counter off the front panel.
- 2 Unplug the wire from the enabling signal tab and plug it onto the reset tab, as shown in image 2 of figure 16.
- 3 Fit the hours counter back onto the front panel.
- 4 Apply power to the 1-phase pump and press the Start button; the hours counter will immediately reset to zero.
- 5 Remove power to the 1-phase pump and wait two minutes for the residual voltage to discharge; then take the hours counter off the front panel.
- 6 Unplug the wire from the reset tab and replace it onto the enabling signal tab, as shown in image 1 of figure 16.
- 7 Fit the hours counter back onto the front panel.
- 8 Apply power to the unit and press the Start button; check if the hourglass flickers, which means it is ready to start to counting.

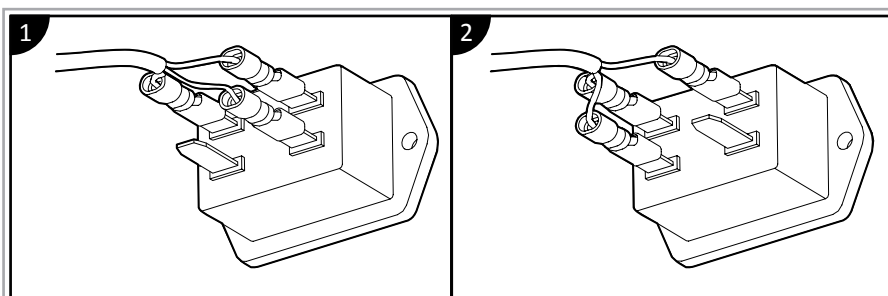

Figure 16 Resetting the hours counter

Maintenance

5.13 Resetting the hours counter 3-phase pump

- 1 Remove power to the 3-phase pump and isolate the incoming electrical supply.
 - 2 Remove the electric terminal box using the procedure documented in section 3.8
 - 3 With power removed to the 3-phase pump; the hours counter should remain powered as it has an embedded battery – check the display to ensure the counter is still working.
 - 4 On the printed circuit board of the electric terminal box there is a three pin reset connector/jumper – “RESET HOURS COUNTER” (Item 1, figure 17). Move the jumper to the reset pins – following the symbol on the board.
 - 5 Wait approximately 5 seconds for the counter to reset.
 - 6 After resetting, move the jumper back to its default position.
- Reassemble the electric terminal box and fan cowl as per section 3.8

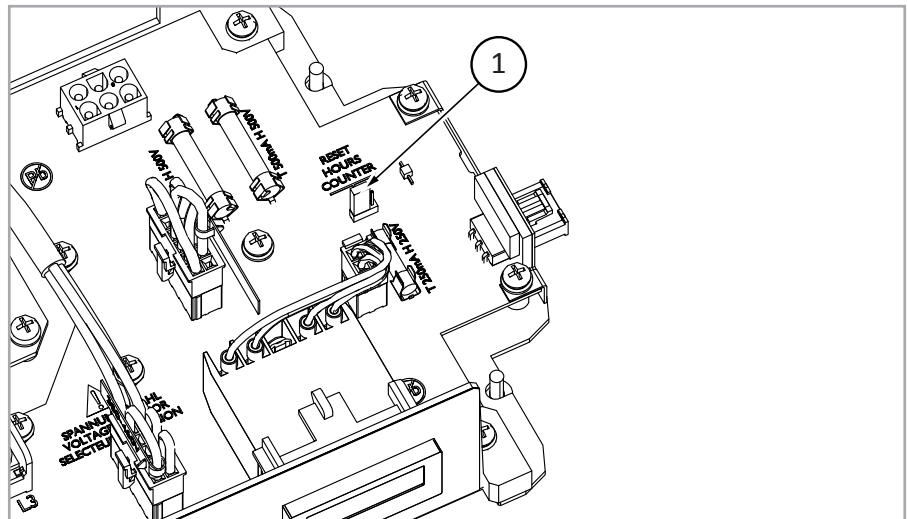

Figure 17 Hours counter reset

5.14 Battery replacement - 3-phase hours counter

Leybold do not consider the replacement of the battery within the hours counter as a customer function. In the event of failure, please contact Leybold for further guidance on battery replacement.

5.15 Leybold service

Whenever you send us in equipment, indicate whether the equipment is contaminated or is free of substances which could pose a health hazard. If it is contaminated, specify exactly which substances are involved. You must use the form we have prepared for this purpose.

A copy of the form has been reproduced at the end of these Operating Instructions: "Declaration of Contamination for Compressors, Vacuum Pumps and Components". Another suitable form is available from www.leybold.com → Downloads → Download Documents.

Attach the form to the equipment or enclose it with the equipment.

This statement detailing the type of contamination is required to satisfy legal requirements and for the protection of our employees.

We must return to the sender any equipment which is not accompanied by a contamination statement.

Troubleshooting

6 Troubleshooting

Malfunction	Likely cause	Remedy
The pump has failed to start or has stopped	<p>The electrical supply fuse has blown.</p> <p>The motor is incorrectly wired (3-Phase pump only)</p> <p>The operating voltage does not match that of the motor (3-Phase pump only)</p> <p>The ambient temperature is too high.</p> <p>The cooling air supply is insufficient or is too hot.</p> <p>The process gas is too hot or the throughput is too high.</p> <p>The fan is not working or is not connected.</p> <p>The motor is faulty.</p>	
The pump cycles between a running and stopped state, but with power applied (3-Phase pump only)	<p>The motor is incorrectly wired.</p> <p>The operating voltage does not match that of the motor.</p> <p>The ambient temperature is too high.</p> <p>The cooling air supply is insufficient or is too hot.</p> <p>The process gas is too hot or the throughput is too high.</p> <p>The fan is not working or is not connected.</p>	
The pump has failed to achieve the required performance	<p>Gas ballast may be selected.</p> <p>If the electrical supply voltage is more than 10% below the lowest voltage specified on the user interface panel, the pump may operate but deliver a degraded vacuum performance.</p> <p>There is a leak in the system.</p> <p>Tip seals may need further run-in, typically 24 hours, with some requiring up to a maximum of 100 hours.</p> <p>The pressure measurement technique or gauge head is unsuitable or gives an incorrect indication of pressure.</p> <p>The vacuum fittings are dirty or damaged.</p> <p>The inlet strainer is blocked.</p> <p>The connecting pipelines are too long or too small in diameter; conductance.</p> <p>There is high pressure or a blockage in the exhaust line.</p> <p>The pump contains traces of process vapours.</p> <p>The pump is outside the specified range of operating conditions.</p> <p>The tip seals need replacing.</p> <p>The pump is in standby mode.</p> <p>The motor shaft rotates in the wrong direction (3-Phase pump only)</p>	<p>To close gas ballast, turn the control a quarter turn so that the valve snaps shut. Use this setting to achieve the best possible vacuum. If the pump has been used to pump condensable vapours or is to pump a large chamber that has been exposed to atmospheric air (water vapour), it may be necessary to run for at least an hour on gas ballast.</p> <p>Replace the fittings.</p> <p>Clean or replace the strainer.</p> <p>Run 12 hours with gas ballast.</p>

Troubleshooting

Malfunction	Likely cause	Remedy
Poor ultimate vacuum	<p>The pump is not running correctly.</p> <p>There is a pulse at the exhaust with the gas ballast set to zero: Pump is leaking.</p> <p>There is no pulse at the exhaust with the gas ballast set to zero: Pump is not leaking.</p>	<p>Connect it correctly.</p> <p>Find the leak and rectify.</p> <p>Change the tip seals.</p>
The pump is noisy	<p>The inlet is open.</p> <p>The gas ballast is open.</p> <p>Scroll clash.</p> <p>Bearing needs servicing.</p> <p>Contamination</p> <p>Motor needs servicing.</p>	<p>Seal off inlet.</p> <p>Set Gas ballast to (0) zero, if possible.</p> <p>Remove fixed scroll, inspect scroll and clean.</p> <p>Return the pump to Leybold.</p> <p>Remove fixed scroll, clean scroll and plenum chamber.</p> <p>Return the pump to Leybold.</p>
The pump surface temperature is high	<p>The ambient temperature is too high.</p> <p>The cooling fan is not running.</p> <p>The process gas is too hot or the maximum continuous operating pressure has been exceeded.</p>	

Troubleshooting

6.1 Alarm indicator codes – 1-phase pump

Whenever a fail condition becomes active the red alarm indicator shows a flashing sequence. If the error light is on continuously this indicates a problem has been found with the embedded software. In this case, try cycling the power. If cycling the power does not clear the indication, a software download may be required. In this situation, contact the supplier or Leybold. If the alarm indicator is flashing, identify the error flash code.

There is a sufficient off period between each subsequent cycle repetition to clearly mark the start of a new flash sequence. The duration of a long flash (L) is equal to 3 times the duration of a short flash (0.5 s).

Error flash position	Error flash sequence	Comment	Actions
0	ssssss	Overload timeout.	Check whether the pump is not running under constant high pressure or the inlet or outlet is not blocked.
1	Lsssss	Controller software error.	Cycle the power to the pump and see whether the error code appears again. If it does, contact the supplier or Leybold.
2	sLssss	Controller failed internal configuration and calibration operation.	Cycle the power to the pump and see whether the error code appears again. If it does, contact the supplier or Leybold.
3	ssLsss	Acceleration timeout.	Check whether the pump is not running under constant high pressure or the inlet or outlet is not blocked.
4	sssLss	Over-current trip activated, or other hardware fault.	Cycle the power to the pump and see whether the error code appears again. If it does, contact the supplier or Leybold.
5	ssssLs	Self test fault.	Cycle the power to the pump and see whether the error code appears again. If it does, contact the supplier or Leybold.
6	ssssL	Serial Control Mode Interlock.	Re-activate serial enable and send a serial command to clear the error code.

Spare parts and accessories

7 Spare parts and accessories

Leybold products, spares and accessories are available from Leybold companies, a world-wide network of distributors and in our online shop <https://www.leyboldproducts.com>. Refer to the last page of this manual.

When ordering, state for each part required:

- Model and item number of your equipment
- Serial number
- Item number and description of part

Spare part	Part No.	Comment
Minor Service Kit SC 7-15 plus	EK117141000	Used to maintain or restore the performance of the pump. (Tip-seal replacement) Refer to Section 5.6.
Minor Service Kit SC 18 plus	EK117141001	
Minor Service Kit SC 7-15 C plus	EK117141002	
Minor Service Kit SC 18 C plus	EK117141003	
Silencer spares kit	EK117141005	Replacement spares for the SCROLLVAC plus silencer 141102A02

Spare parts and accessories

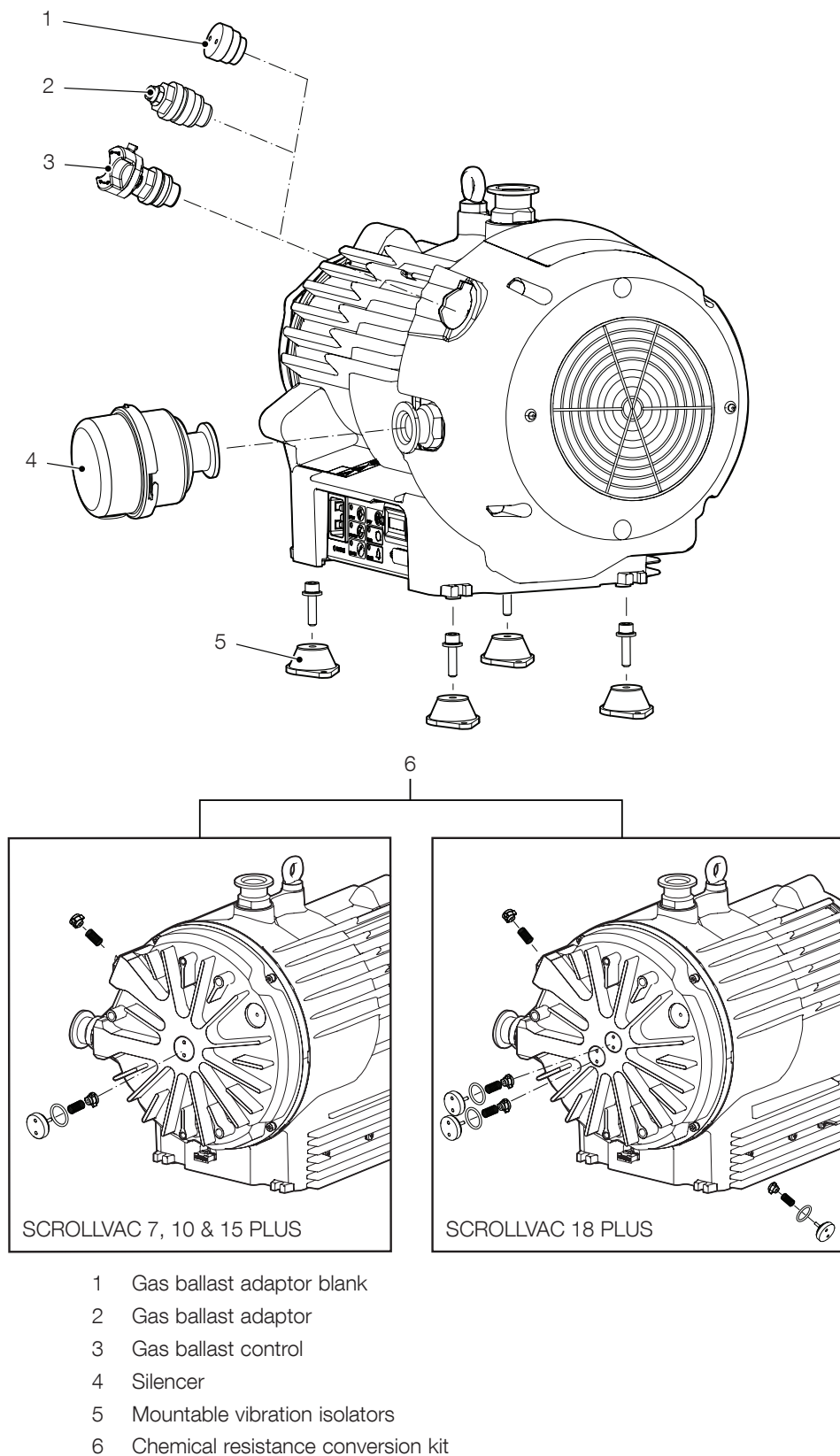

Figure 18 - SCROLLVAC accessories- general view (o-ring seals not shown)

Spare parts and accessories

7.1 Mounting accessories

This Section provides installation, operation and maintenance instructions for the Leybold range of accessories for the SCROLLVAC plus.

The accessories are shown in Figure 18. The Item Numbers for the accessories are listed in the appropriate sections. The accessories must be used as specified in this manual. Read this manual before installing accessories onto the SCROLLVAC plus.

Before installing the accessory:

- Switch off the SCROLLVAC plus and wait until the pump has stopped rotating.
- Isolate the pump controller from the electrical supply.

When ordering accessories, please state for each part required:

- Model and Item Number of the equipment
- Serial number (if any)
- Item Number and description of part.

7.1.1 Gas ballast adaptor blank

This adaptor kit allows the conversion of a standard SCROLLVAC plus pump into an SCROLLVAC H plus version. The gas ballast control is replaced with a blank adaptor so that the gas ballast cannot be accidentally opened.

Supplied equipment: Gas ballast adaptor blank, O-ring 19.6ID X 2.4

Installation

The method for installing the gas ballast adaptor blank follows some of the stages used to install the gas ballast adaptor. To install the gas ballast adaptor blank, refer to stages 1, 2, 3 and 5 of the gas ballast adaptor fitting instructions in Section 7.1.2.

Using a pin spanner (not provided), fit the adaptor blank and tighten to 6 Nm.

Note: As a precaution, Leybold recommends that a complete vacuum leak check be performed following this installation.

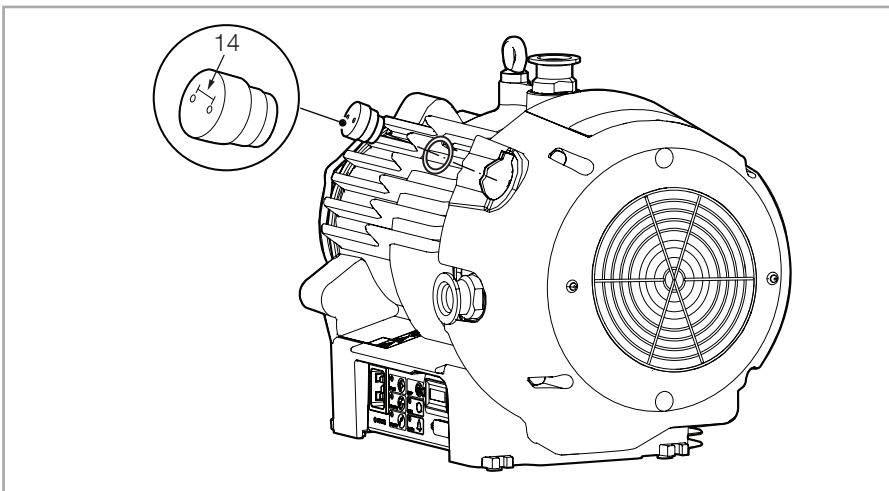

Figure 19 Gas ballast adaptor blank fitting

Spare parts and accessories

7.1.2 Gas ballast adaptor

The gas ballast adaptor fits in place of the gas ballast control. The gas ballast adaptor allows connection of a controlled supply of inert gas such as nitrogen into the low vacuum stage of the pump.

The gas purge can be used to dilute flammable gases down to a safe level (Leybold recommends 1/4 of the Lower Explosive Limit). An inert purge can also be used to reduce the likelihood of gas vapours such as iodine from condensing at the outlet stage of the pump.

Accessory	Part No.	Maximum supply pressure	Gas ballast flow
Gas ballast Adaptor (no restriction)	141100A02	1 bar (abs.)	Standard*
Gas ballast Adaptor (fine restriction)	141100A03	1.5 bar (abs.)	0.5 l/m

* Refer to section 1.7 for standard gas ballast flows

Supplied equipment: Gas ballast adaptor, O-ring 19.6 ID x 2.4

Installation

Ensure the pump is switched off before fitting.

See Figure 20.

1 Undo the 2 off retaining bolts and partially remove the fan cowl.

Caution: Cooling fan supply lead attached.

Carefully disconnect the cooling fan electrical supply lead and remove the fan cowl.

2 Using a 21 mm AF spanner, remove the gas ballast control assembly.

3 Carefully remove the gas ballast control seat and O-ring.

4 Assemble the gas ballast adaptor and new O-ring, ensure the O-ring and seal surface are clean and free of dust or dirt.

5 Reconnect and assemble the cooling fan supply lead and fan cowl (1) in reverse order. Torque the retaining bolts to 3 Nm.

As a precaution, Leybold recommends that a complete a vacuum leak check be performed after this installation.

Ensure the cooling fan operates correctly following the installation of the gas ballast adaptor.

Retain the gas ballast control assembly and seat for future use if required.

Spare parts and accessories

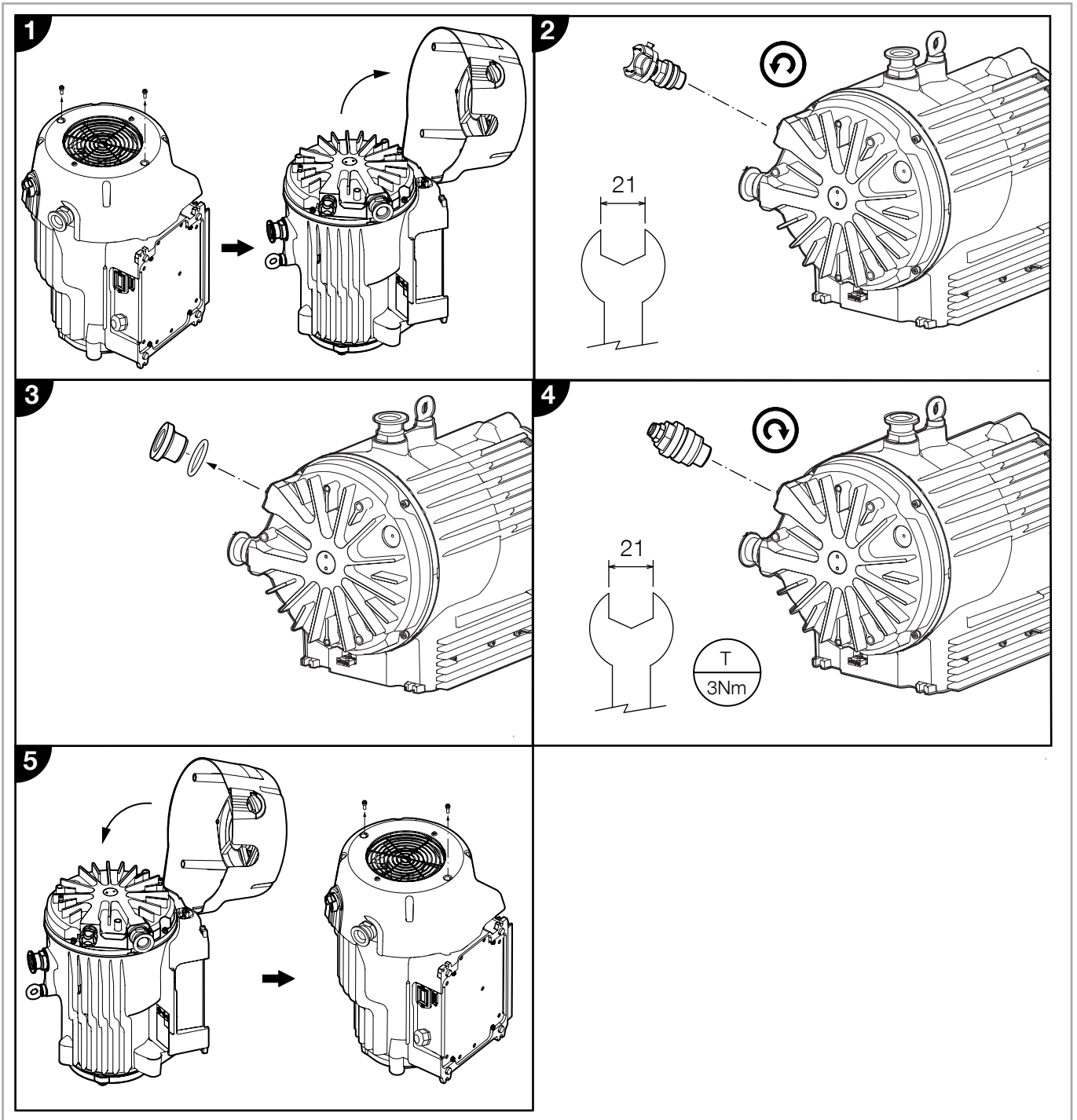

Figure 20 Installing the gas ballast adaptor

Spare parts and accessories

7.1.3 Silencer

The SCROLLVAC plus silencer has two main functions.

- To reduce exhaust noise during pump down and gas ballast operation.
- To collect and retain tip seal dust as the pump is operated.

Exhaust gases exit the exhaust port when the pump is being used to evacuate a process chamber, when the gas ballast control is being used, or both. The noise level when pumping down rises as the throughput increases and the silencer is used to reduce this noise level.

The outer can is made of pressed steel and is split to allow access to the filter elements.

The filter element housing is made from Santoprene® thermoplastic elastomer. The element itself is polyester. The foam block is manufactured from filter foam.

Note: These elements can only be used in dry applications and must not be allowed to moisten.

A pressure relief valve is not fitted to the silencer.

WARNING



The SCROLLVAC plus silencer is not recommended for use with pumping hazardous substances.

The SCROLLVAC plus silencer has been manufactured with an NW 25 fitting to enable fitting to the SCROLLVAC plus pump exhaust. An NW 25 clamp and centering ring are included.

A sectional view of the silencer is shown in figure 21.

Technical data

Maximum back pressure	0.2 bar gauge
Mass	265 g
Port size	NW 25

Installation

Ensure the pump is switched off before fitting the silencer.

1. Clean the face of the pump exhaust.
2. Place the centering O-ring in the end of the NW 25 backing port and seat the silencer in the pump exhaust.
3. Fit the clamp and tighten to secure the silencer.

Silencer maintenance

The foam block and polyester element need to be inspected periodically. Leybold recommends both are replaced every 9000 hours of pump use. The silencer has been designed to handle 10 cc of tip-seal dust without affecting the performance of the pump. The silencer spares kit (Part No. see Section 7) contains both items.

Spare parts and accessories

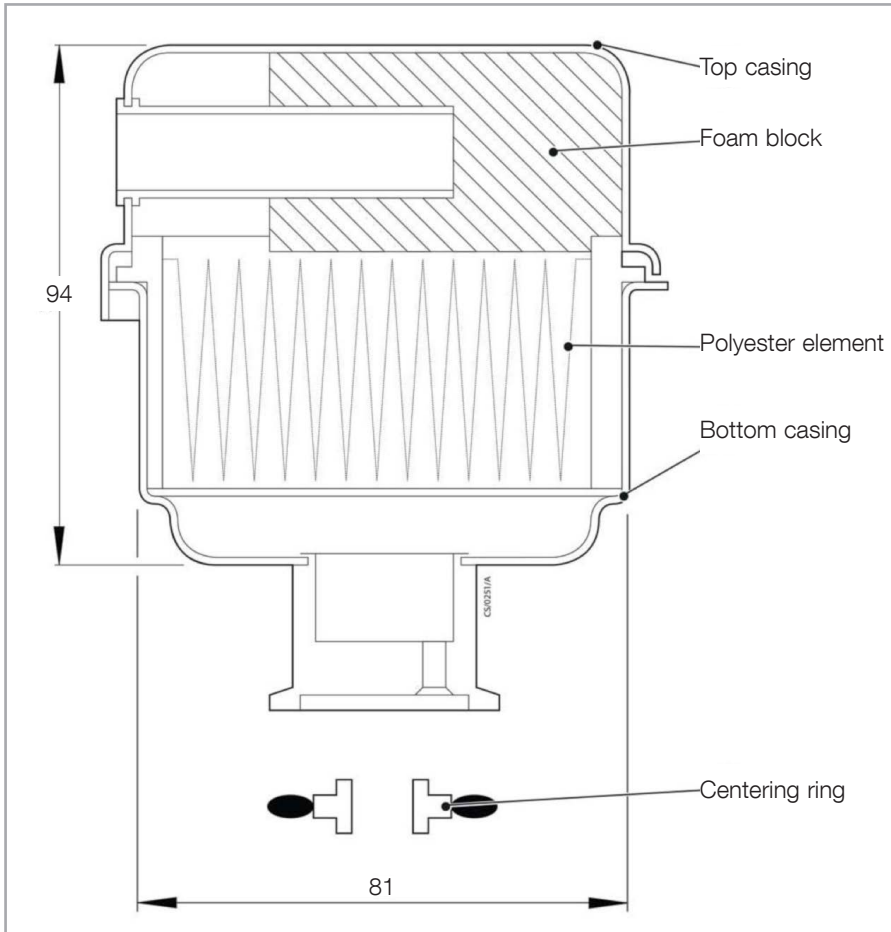

Figure 21 Silencer

Take all necessary precautions if toxic or dangerous substances have been pumped. Wear PPE when handling contaminated filters and filter elements.

WARNING



Do not attempt to dismantle the silencer whilst the pump is running. Ensure the pump is isolated from its electrical supply before removing the silencer.

WARNING



Do not inhale the tip seal dust. Do not blow the tip seal dust from the silencer with compressed air.

Ensure the pump is switched off before removing the silencer.

Remove the NW25 clamp and silencer from the pump exhaust. Hold the top half of the silencer with one hand, and the bottom half with the other hand. Keeping one hand steady, twist clockwise with the other, and the two halves will separate. The polyester element will be retained in the top half. With the element uppermost, lift the element out by lightly gripping the protruding surface of the element. Put the element to one side ready to inspect it. The foam block is pushed onto the outlet pipe and is trapped into position by the polyester element.

Spare parts and accessories

NOTICE



Inspection of elements

The tip seal wear product will begin to decompose if the temperature exceeds 250 °C, giving rise to gaseous fumes that can produce unpleasant symptoms.

The silencer will be contaminated with the process chemicals that have been pumped during operation. Ensure that the pump is decontaminated before maintenance and that adequate precautions are taken to protect people from the effects of dangerous substances if contamination has occurred.

Renewal of the elements is recommended regardless of their level of contamination. Neither element should be heavily contaminated with tip seal dust, but if either is, they **MUST** be replaced or cleaned in order to avoid a build up of dust that may adversely affect performance. Rinse the elements through with soap and water to clean them. Observe local guidelines to advise the safe disposal of PTFE dust.

Replacement of elements

Fitting the new elements is the reverse of removal, fit the foam block first and then the polyester element. Fit both halves of the silencer together and twist anticlockwise to secure. Ensure fastening is complete by looking at the bayonet fitting and checking it is home.

7.1.4 Mountable vibration isolators

The mountable vibration isolators can be used to reduce the transmitted vibration from the pump to a mounting surface such as a system frame.

The mountable vibration isolators have fixing holes to allow the pump to be bolted to the floor or system frame.

Supplied equipment: 4 vibration isolators, 4 pump fixing screws, 4 plain washers, 4 shake-proof washers

Maximum load per isolator	18 kg
---------------------------	-------

Nominal deflection	4 mm
--------------------	------

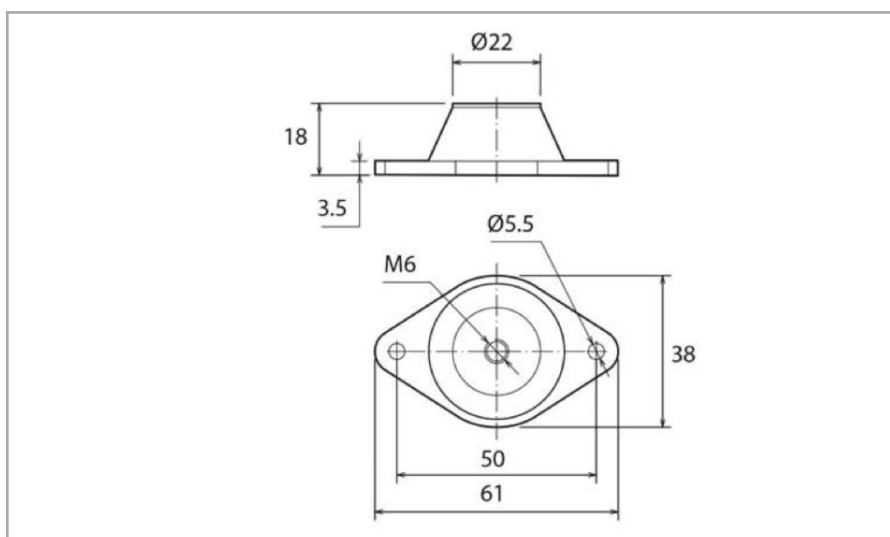

Figure 22 Vibration isolator dimensions

Spare parts and accessories

Installation

Ensure the pump is switched off before fitting.

1. Unscrew and remove the standard rubber feet if fitted.
2. Fit the vibration isolators to the pump using the screws and washers provided.
3. Using 5 mm bolts (not supplied), fix the vibration isolators bolted to the fixing surface or system frame.

Leybold recommends the fitting of flexible tubing or bellows connections between the pump-inlet and the pump-outlet and the rest of the system, to prevent the transmission of stress to the vacuum pipelines and/or equipment.

7.1.5 Chemical resistance conversion kit

The adaptor kit allows the conversion of a standard SCROLLVAC plus pump into an SCROLLVAC plus C version. This conversion may be necessary if anticipating the use of the pump on applications involving corrosive substances.

Supplied equipment:

Part	Quantity for SCROLLVAC 7/10/15 plus	Quantity for SCROLLVAC 18 plus
Valve pad (Chemraz)	2	4
Valve spring	2	4
19.6ID O-ring	2	2
NW25 stainless steel port	2	2
NW25 port O-ring	2	2

Installation

Ensure the pump is switched off before fitting. Discard all used 19.6 ID O-ring's.

Refer to figure 23.

Spare parts and accessories

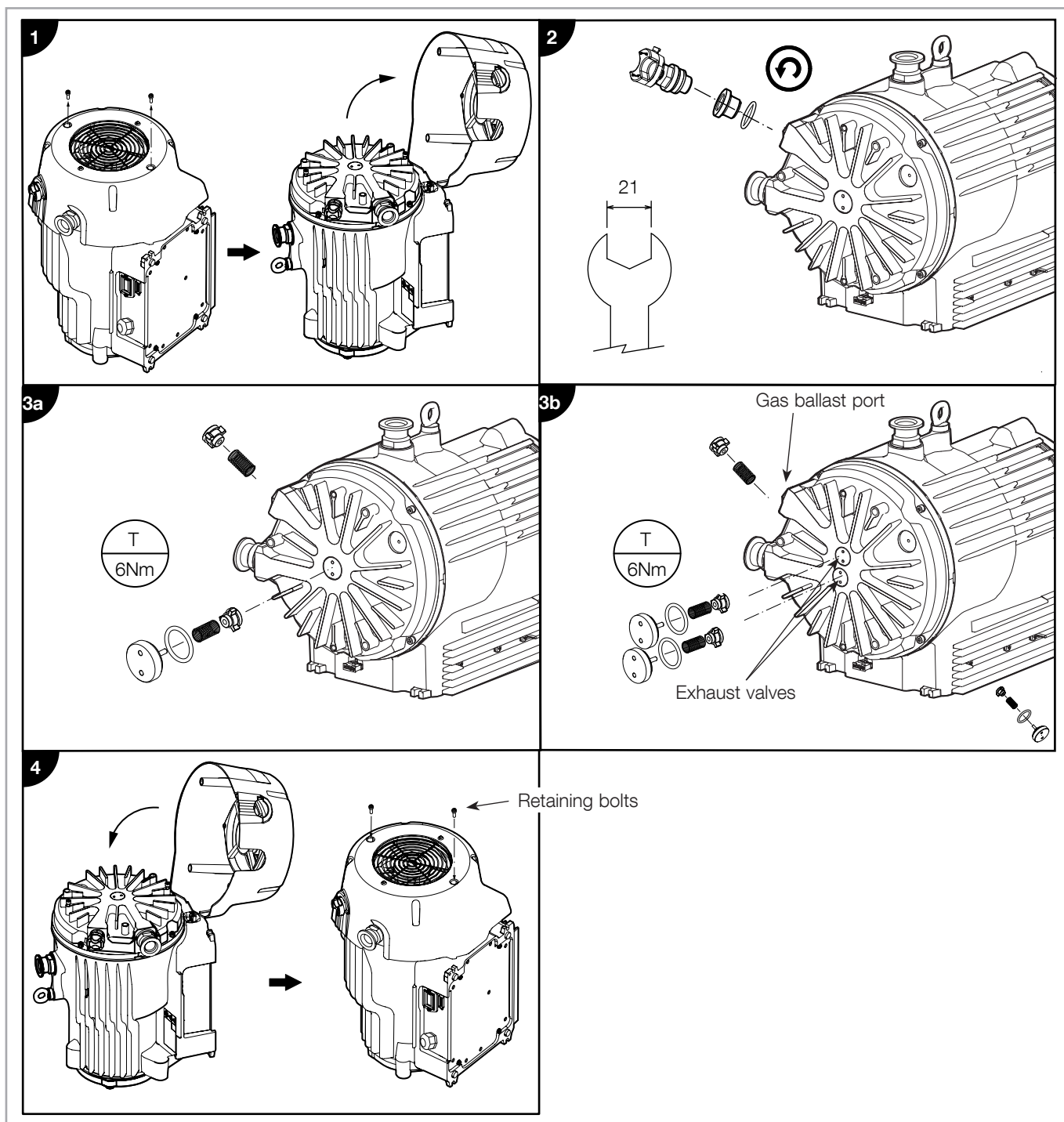

Figure 23 Installing the chemical resistance conversion kit

Spare parts and accessories

Valve pad conversion

- 1 Undo the 2 off retaining bolts and partially remove the fan cowl. Caution: Cooling fan supply lead attached. Carefully disconnect the cooling fan electrical supply lead and remove the fan cowl.
- 2 Using a 21 mm AF spanner (not supplied), remove the gas ballast control assembly, seat and O-ring.
- 3a (SCROLLVAC 7/10/15 plus) Remove the remaining items (spring and pad) from the gas ballast port. Using a pin spanner, remove the exhaust valve end cap, O-ring, spring and valve pad.
- 3b (SCROLLVAC 18 plus) The SCROLLVAC 18 plus uses two addition exhaust valves. Remove these using the same procedure as in 3a.
- 4 Assemble the new valve parts in reverse order. Reconnect and assemble the cooling fan supply lead and fan cowl in reverse order. Torque the retaining bolts to 3 Nm.

Inlet/exhaust port conversion

Using a 30 mm AF spanner (not supplied), remove both the inlet and exhaust ports. Locate the stainless steel ports provided in the kit and assemble using new O-rings in reverse order.

As a precaution, Leybold recommends a complete a vacuum leak check after this installation.

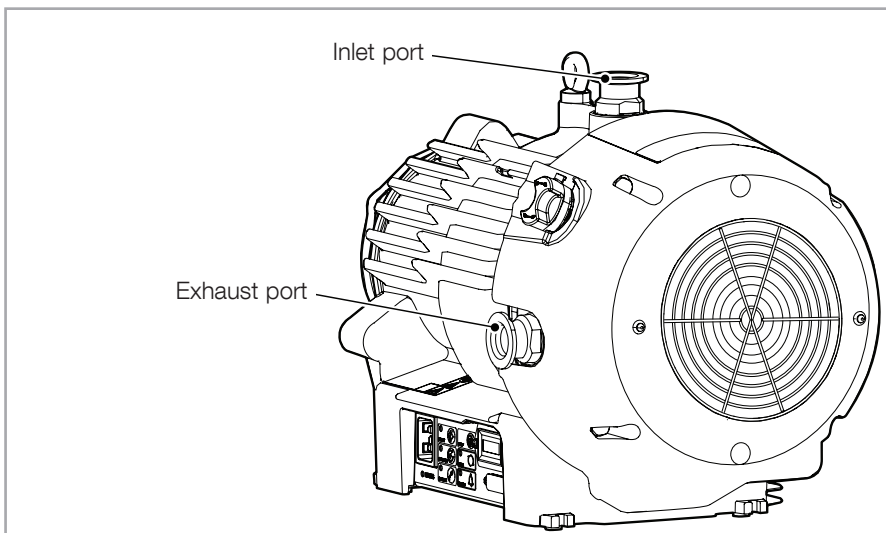

Figure 24 Inlet/exhaust port conversion

Disposal

8 Waste Disposal

The equipment may have been contaminated by the process or by environmental influences. In this case the equipment must be decontaminated in accordance with the relevant regulations. We offer this service at fixed prices. Further details are available on request.

WARNING



Contaminated parts can be detrimental to health and environment. Before beginning with any work, first find out whether any parts are contaminated. Adhere to the relevant regulations and take the necessary precautions when handling contaminated parts.

Separate clean components according to their materials, and dispose of these accordingly. We offer this service. Further details are available on request.

EU Declaration of Conformity

(Translation of original Declaration of Conformity)

The manufacturer: Leybold GmbH
Bonner Strasse 498, D-50968 Köln, Germany

hereby declares that the products specified and listed below which we have placed on the market, comply with the applicable EU Directives. This declaration becomes invalid if modifications, except those of intended products options, are made to the product without agreement of Leybold GmbH.

Product designation: Scroll vacuum pump

Type designation: **Part numbers:**

1-ph	Standard	H-Version	C-Version
SCROLLVAC 7 plus	141007V10	141007V11	141007V12
SCROLLVAC 10 plus	141010V10	141010V11	141010V12
SCROLLVAC 15 plus	141015V10	141015V11	141015V12
SCROLLVAC 18 plus	141018V10	141018V11	141018V12

3-ph	Standard	H-Version	C-Version
SCROLLVAC 7 plus	141007V30	141007V31	141007V32
SCROLLVAC 10 plus	141010V30	141010V31	141010V32
SCROLLVAC 15 plus	141015V30	141015V31	141015V32
SCROLLVAC 18 plus	141018V30	141018V31	141018V32

The products comply with the following Directives:

Machinery Directive (2006/42/EC)

The safety objectives of the Low Voltage Directive 2014/35/EU were complied with in accordance with Appendix 1 No. 1.5.1 of Machinery Directive 2006/42/EC.

Electromagnetic Compatibility (EMC) Directive (2014/30/EU)

Restriction of Hazardous Substances (RoHS) Directive (2011/65/EU)

ATEX Directive on use in Potentially Explosive Atmospheres (2014/34/EU)

 h II B T4 Gc Internal Atmospheres Only, Tech File ref TCF 209

The following harmonized standards have been applied:

- EN 1012-2:1996+A1:2009 Compressors and vacuum pumps - Safety requirements Part 2: Vacuum pumps
- EN 61010-1:2010 Safety requirements for electrical equipment for measurement, control, and laboratory use - Part 1: General requirements
- EN 61326-1:2013 Electrical equipment for measurement, control and laboratory use -EMC requirements - Part 1: General requirements
Emissions: Group 1, Class A
Immunity: Industrial electromagnetic environment
- EN80079-36: 2016 Non-electrical equipment for explosive atmospheres - Basic method and requirements
- EN80079-37: 2016 Non-electrical equipment for explosive atmospheres - Non-electrical type of protection constructional safety "c"

Documentation officer: Leybold GmbH, Herbert Etges, Bonner Straße 498, D-50968 Köln
T: +49(0)221 347 0, F: +49(0)221 347 1250
documentation@leybold.com

Burgess Hill, 01/11/2017

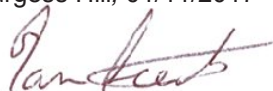

Ian Keech
VP Engineering, High Vacuum Division

Certificates

The SCROLLVAC plus pumps have been certified by the TÜV Rheinland of North America according to the requirements of

- UL 61010-1: 2012
- CAN/CSA No.61010-1-12

The components are in compliance to the tested standards.

- cTUVus File no. 31880570.002
- cTUVus Certificate no. CU 72180252 01

The TÜV Rheinland of North America is a “Nationally Recognized Testing Laboratory” (**NRTL**) for the USA and Canada.



This product has been certified to the requirements of CAN/CSA-C22.2 No. 61010-1-12, or a later version of the same standard incorporating the same level of testing requirements.

Material Declaration

In accordance with the requirements of the Chinese regulatory requirement on the Management Methods for the Restriction of the Use of Hazardous Substances in Electrical and Electronic Products Order No. 32 (also known as 'China RoHS2') and SJ/T 11364 Marking for the Restricted Use of Hazardous Substances in Electronic and Electrical Products:

Product	Product Label	Meaning
SCROLLVAC 7 plus SCROLLVAC 10 plus SCROLLVAC 15 plus SCROLLVAC 18 plus		This product contains hazardous substances in at least one of the homogeneous materials used which are above the limit requirement in GB/T 26572 as detailed in the declaration table below. These parts can safely be used for the environmental protection use period as indicated.





 材料成分声明
Materials Content Declaration

部件名称 Part name	有害物质 Hazardous Substances					
	铅 Lead (Pb)	汞 Mercury (Hg)	镉 Cadmium (Cd)	六价铬 Hexavalent Chromium (Cr VI)	多溴联苯 Polybrominated biphenyls (PBB)	多溴二苯醚 Polybrominated diphenyl ethers (PBDE)
电子元件和控件 Electronics and Controls	X	O	X	O	O	O
O: 表示该有害物质在该部件的所有均质材料中的含量低于 GB/T 26572 标准规定的限量要求。 O: Indicates that the hazardous substance contained in all of the homogeneous materials for this part is below the limit requirement in GB/T 26572. X: 表示该有害物质在该部件的至少一种均质材料中的含量超出 GB/T26572 标准规定的限量要求。 X: Indicates that the hazardous substance contained in at least one of the homogeneous materials used for this part is above the limit requirement of GB/T26572.						

These products are EU RoHS compliant, the following Exemptions apply:

- 7(a) Lead in in high melting temperature type solder (i.e lead based alloys containing 85% by weight or more lead)
- (c) I Electrical and electronic components containing lead in a glass or ceramic other than dielectric ceramic in capacitors, e.g. piezoelectronic devices, or in a glass or ceramic matrix compound
- 7(c) II Lead in dielectric ceramic in capacitors for a rated voltage of 125 V AC or 250 V DC or higher
- 8(b) Cadmium and its compounds in electrical contacts
- 15 Lead in solders to complete a viable electrical connection between semiconductor die and carrier within integrated circuit flip chip packages

Packaging Information

Pallet	Over-shipper	Protection Pieces	Support Braces
 NW	 CB	 PP	 FE
Recyclable Natural Wood	Recyclable Cardboard	Recyclable Polypropylene	Recyclable Mild Steel

Declaration of Contamination of Compressors, Vacuum Pumps and Components

The repair and / or servicing of compressors, vacuum pumps and components will be carried out only if a correctly completed declaration has been submitted. Non-completion will result in delay. The manufacturer can refuse to accept any equipment without a declaration.

A separate declaration has to be completed for each single component.

This declaration may be completed and signed only by authorized and qualified staff.

Customer/Dep./Institute : _____ Address : _____ _____ Person to contact: _____ Phone : _____ Fax: _____ End user: _____	Reason for return: <input checked="" type="checkbox"/> applicable please mark Repair: <input type="checkbox"/> chargeable <input type="checkbox"/> warranty Exchange: <input type="checkbox"/> chargeable <input type="checkbox"/> warranty <input type="checkbox"/> Exchange already arranged / received Return only: <input type="checkbox"/> rent <input type="checkbox"/> loan <input type="checkbox"/> for credit Calibration: <input type="checkbox"/> DKD <input type="checkbox"/> Factory-calibr. <input type="checkbox"/> Quality test certificate DIN 55350-18-4.2.1																																																															
A. Description of the Leybold product: _____ Failure description: _____ Material description : _____ Catalog number: _____ Additional parts: _____ Serial number: _____ Application-Tool: _____ Type of oil (ForeVacuum-Pumps) : _____ Application- Process: _____																																																																
B. Condition of the equipment <table style="width:100%; border-collapse: collapse;"> <thead> <tr> <th style="width:40%;"></th> <th style="width:10%; text-align: center;">No¹⁾</th> <th style="width:10%; text-align: center;">Yes</th> <th style="width:10%; text-align: center;">No</th> <th style="width:20%;"></th> <th style="width:10%; text-align: center;">No¹⁾</th> <th style="width:10%; text-align: center;">Yes</th> </tr> </thead> <tbody> <tr> <td>1. Has the equipment been used</td> <td style="text-align: center;"><input type="checkbox"/></td> <td style="text-align: center;"><input type="checkbox"/></td> <td style="text-align: center;"><input type="checkbox"/></td> <td style="text-align: center;">→</td> <td>toxic</td> <td style="text-align: center;"><input type="checkbox"/></td> <td style="text-align: center;"><input type="checkbox"/></td> </tr> <tr> <td>2. Drained (Product/service fluid)</td> <td style="text-align: center;"><input type="checkbox"/></td> <td style="text-align: center;"><input type="checkbox"/></td> <td style="text-align: center;"><input type="checkbox"/></td> <td></td> <td>corrosive</td> <td style="text-align: center;"><input type="checkbox"/></td> <td style="text-align: center;"><input type="checkbox"/></td> </tr> <tr> <td>3. All openings sealed airtight</td> <td style="text-align: center;"><input type="checkbox"/></td> <td style="text-align: center;"><input type="checkbox"/></td> <td style="text-align: center;"><input type="checkbox"/></td> <td></td> <td>flammable</td> <td style="text-align: center;"><input type="checkbox"/></td> <td style="text-align: center;"><input type="checkbox"/></td> </tr> <tr> <td>4. Purged</td> <td style="text-align: center;"><input type="checkbox"/></td> <td style="text-align: center;"><input type="checkbox"/></td> <td style="text-align: center;"><input type="checkbox"/></td> <td></td> <td>explosive ²⁾</td> <td style="text-align: center;"><input type="checkbox"/></td> <td style="text-align: center;"><input type="checkbox"/></td> </tr> <tr> <td colspan="4">If yes, which cleaning agent</td> <td></td> <td>radioactive ²⁾</td> <td style="text-align: center;"><input type="checkbox"/></td> <td style="text-align: center;"><input type="checkbox"/></td> </tr> <tr> <td colspan="4">and which method of cleaning</td> <td></td> <td>microbiological ²⁾</td> <td style="text-align: center;"><input type="checkbox"/></td> <td style="text-align: center;"><input type="checkbox"/></td> </tr> <tr> <td colspan="4">¹⁾ If answered with "No", go to D. ←</td> <td></td> <td>other harmful substances</td> <td style="text-align: center;"><input type="checkbox"/></td> <td style="text-align: center;"><input type="checkbox"/></td> </tr> </tbody> </table>			No ¹⁾	Yes	No		No ¹⁾	Yes	1. Has the equipment been used	<input type="checkbox"/>	<input type="checkbox"/>	<input type="checkbox"/>	→	toxic	<input type="checkbox"/>	<input type="checkbox"/>	2. Drained (Product/service fluid)	<input type="checkbox"/>	<input type="checkbox"/>	<input type="checkbox"/>		corrosive	<input type="checkbox"/>	<input type="checkbox"/>	3. All openings sealed airtight	<input type="checkbox"/>	<input type="checkbox"/>	<input type="checkbox"/>		flammable	<input type="checkbox"/>	<input type="checkbox"/>	4. Purged	<input type="checkbox"/>	<input type="checkbox"/>	<input type="checkbox"/>		explosive ²⁾	<input type="checkbox"/>	<input type="checkbox"/>	If yes, which cleaning agent					radioactive ²⁾	<input type="checkbox"/>	<input type="checkbox"/>	and which method of cleaning					microbiological ²⁾	<input type="checkbox"/>	<input type="checkbox"/>	¹⁾ If answered with "No", go to D. ←					other harmful substances	<input type="checkbox"/>	<input type="checkbox"/>
	No ¹⁾	Yes	No		No ¹⁾	Yes																																																										
1. Has the equipment been used	<input type="checkbox"/>	<input type="checkbox"/>	<input type="checkbox"/>	→	toxic	<input type="checkbox"/>	<input type="checkbox"/>																																																									
2. Drained (Product/service fluid)	<input type="checkbox"/>	<input type="checkbox"/>	<input type="checkbox"/>		corrosive	<input type="checkbox"/>	<input type="checkbox"/>																																																									
3. All openings sealed airtight	<input type="checkbox"/>	<input type="checkbox"/>	<input type="checkbox"/>		flammable	<input type="checkbox"/>	<input type="checkbox"/>																																																									
4. Purged	<input type="checkbox"/>	<input type="checkbox"/>	<input type="checkbox"/>		explosive ²⁾	<input type="checkbox"/>	<input type="checkbox"/>																																																									
If yes, which cleaning agent					radioactive ²⁾	<input type="checkbox"/>	<input type="checkbox"/>																																																									
and which method of cleaning					microbiological ²⁾	<input type="checkbox"/>	<input type="checkbox"/>																																																									
¹⁾ If answered with "No", go to D. ←					other harmful substances	<input type="checkbox"/>	<input type="checkbox"/>																																																									
C. Description of processed substances (Please fill in absolutely) 1. What substances have come into contact with the equipment ? Trade name and / or chemical term of service fluids and substances processed, properties of the substances According to safety data sheet (e.g. toxic, inflammable, corrosive, radioactive)																																																																
<table border="1" style="width:100%; border-collapse: collapse;"> <thead> <tr> <th style="width:5%;">X</th> <th style="width:30%;">Tradename:</th> <th style="width:65%;">Chemical name:</th> </tr> </thead> <tbody> <tr><td> </td><td> </td><td> </td></tr> <tr><td>a)</td><td> </td><td> </td></tr> <tr><td>b)</td><td> </td><td> </td></tr> <tr><td>c)</td><td> </td><td> </td></tr> <tr><td>d)</td><td> </td><td> </td></tr> </tbody> </table>		X	Tradename:	Chemical name:				a)			b)			c)			d)																																															
X	Tradename:	Chemical name:																																																														
a)																																																																
b)																																																																
c)																																																																
d)																																																																
2. Are these substances harmful ? ← 3. Dangerous decomposition products when heated ? If yes, which ? _____																																																																
²⁾ Components contaminated by microbiological, explosive or radioactive products/substances will not be accepted without written evidence of decontamination.																																																																

D. Legally binding declaration

I / we hereby declare that the information supplied on this form is accurate and sufficient to judge any contamination level.

 Name of authorized person (block letters) : _____

 Date _____ signature of authorized person _____

firm stamp

Sales and Service

Germany

Leybold GmbH
Bonner Strasse 498
D-50968 Cologne
T: +49-(0)221-347 1234
F: +49-(0)221-347 31234
sales@leybold.com
www.leybold.com

Leybold GmbH
Sales Area North
Branch Office Berlin
Industriestrasse 10b
D-12099 Berlin
T: +49-(0)30-435 609 0
F: +49-(0)30-435 609 10
sales.bn@leybold.com

Leybold GmbH
Sales Office South
Branch Office Munich
Karl-Hammerschmidt-Strasse 34
D-85609 Aschheim-Dornach
T: +49-(0)89-357 33 9-10
F: +49-(0)89-357 33 9-33
sales.mn@leybold.com
service.mn@leybold.com

Leybold Dresden GmbH
Service Competence Center
Zur Wetterwarte 50, Haus 304
D-01109 Dresden
Service:
T: +49-(0)351-88 55 00
F: +49-(0)351-88 55 041
info.dr@leybold.com

Europe

Belgium

Leybold Nederland B.V.
Belgisch bijkantoor
Leuvensesteenweg 542-9A
B-1930 Zaventem
Sales:
T: +32-2-711 00 83
F: +32-2-720 83 38
sales.zv@leybold.com
Service:
T: +32-2-711 00 82
F: +32-2-720 83 38
service.zv@leybold.com

France

Leybold France S.A.S.
Parc du Technopolis, Bâtiment Beta
3, Avenue du Canada
F-91940 Les Ulis cedex
Sales and Service:
T: +33-1-69 82 48 00
F: +33-1-69 07 57 38
info.ctb@leybold.com
sales.ctb@leybold.com

Leybold France S.A.S.
Valence Factory
640, Rue A. Bergès
B.P. 107
F-26501 Bourg-lès-Valence Cedex
T: +33-4-75 82 33 00
F: +33-4-75 82 92 69
marketing.vc@leybold.com

Great Britain

Leybold UK LTD.
Unit 9
Silverglade Business Park
Leatherhead Road
Chessington
Surrey (London)
KT9 2QL
Sales:
T: +44-13-7273 7300
F: +44-13-7273 7301
sales.ln@leybold.com
Service:
T: +44-13-7273 7320
F: +44-13-7273 7303
service.ln@leybold.com

Italy

Leybold Italia S.r.l.
Via Filippo Brunelleschi 2
I-20093 Cologno Monzese
Sales:
T: +39-02-27 22 31
F: +39-02-27 20 96 41
sales.mi@leybold.com
Service:
T: +39-02-27 22 31
F: +39-02-27 22 32 17
service.mi@leybold.com

Netherlands

Leybold Nederland B.V.
Floridadreef 102
NL-3565 AM Utrecht
Sales and Service:
T: +31-(30) 242 63 30
F: +31-(30) 242 63 31
sales.ut@leybold.com
service.ut@leybold.com

Switzerland

Leybold Schweiz AG
Hinterbergstrasse 56
CH-6312 Steinhausen
Warehouse and shipping address:
Riedthofstrasse 214
CH-8105 Regensdorf
Sales:
T: +41-44-308 40 50
F: +41-44-302 43 73
sales.zh@leybold.com
Service:
T: +41-44-308 40 62
F: +41-44-308 40 60
service.zh@leybold.com

Spain

Leybold Hispánica, S.A.
C/. Huelva, 7
E-08940 Cornellá de Llobregat
(Barcelona)
Sales:
T: +34-93-666 43 11
F: +34-93-666 43 70
sales.ba@leybold.com
Service:
T: +34-93-666 46 11
F: +34-93-685 43 70
service.ba@leybold.com

Headquarter

Leybold GmbH
Bonner Strasse 498
D-50968 Cologne
T: +49-(0)221-347-0
F: +49-(0)221-347-1250
info@leybold.com

America

USA

Leybold USA Inc.
5700 Mellon Road
USA-Export, PA 15632
T: +1-724-327-5700
F: +1-724-325-3577
info.ex@leybold.com
Sales:
T: +1-724-327-5700
F: +1-724-333-1217
Service:
T: +1-724-327-5700
F: +1-724-325-3577

Brazil

Leybold do Brasil
Rod. Vice-Prefeito Hermenegildo Tonolli,
nº. 4413 - 6B
Distrito Industrial
Jundiá - SP
CEP 13.213-086
Sales and Service:
T: +55 11 3395 3180
F: +55 11 99467 5934
sales.ju@leybold.com
service.ju@leybold.com

Asia

P. R. China

Leybold (Tianjin)
International Trade Co. Ltd.
Beichen Economic
Development Area (BEDA),
No. 8 Western Shuangchen Road
Tianjin 300400
China
Sales and Service:
T: +86-400 038 8989
T: +86-800 818 0033
F: +86-22-2697 4061
F: +86-22-2697 2017
sales.tj@leybold.com
service.tj@leybold.com

India

Leybold India Pvt Ltd.
T-97/2, MIDC Bhosari
Pune-411 026
Indien
Sales and Service:
T: +91-80-2783 9925
F: +91-80-2783 9926
sales.bgj@leybold.com
service.bgj@leybold.com

Japan

Leybold Japan Co., Ltd.
Headquarters
Shin-Yokohama A.K.Bldg., 4th floor
3-23-3, Shin-Yokohama
Kohoku-ku, Yokohama-shi
Kanagawa-ken 222-0033
Japan
Sales:
T: +81-45-471-3330
F: +81-45-471-3323
sales.yh@leybold.com

Leybold Japan Co., Ltd.
Tsukuba Technical Service Center
1959, Kami-yokoba
Tsukuba-shi, Ibaraki-shi 305-0854
Japan
Service:
T: +81-29 839 5480
F: +81-29 839 5485
service.iik@leybold.com

Malaysia

Leybold Malaysia
Leybold Singapore Pte Ltd.
No. 1 Jalan Hi-Tech 2/6
Kulim Hi-Tech Park
Kulim, Kedah Darul
Aman 09000
Malaysia
Sales and Service:
T: +604 4020 222
F: +604 4020 221
sales.ku@leybold.com
service.ku@leybold.com

South Korea

Leybold Korea Ltd.
3F. Jellzone 2 Tower
Jeongja-dong 159-4
Bundang-gu Sungnam-si
Gyeonggi-do
Bundang 463-384, Korea
Sales:
T: +82-31 785 1367
F: +82-31 785 1359
sales.bd@leybold.com
Service:
623-7, Upsung-Dong
Cheonan-Si
Chungcheongnam-Do
Korea 330-290
T: +82-41 589 3035
F: +82-41 588 0166
service.cn@leybold.com

Singapore

Leybold Singapore Pte Ltd.
42 Loyang Drive
Loyang Industrial Estate
Singapore 508962
Singapore
Sales and Service:
T: +65-6303 7030
F: +65-6773 0039
sales.sg@leybold.com
service.sg@leybold.com

Taiwan

Leybold Taiwan Ltd.
10F., No. 32, Chenggong 12th St.,
Zhubei City, Hsinchu County 302
Taiwan, R.O.C.
Sales and Service:
T: +886-3-500 1688
F: +886-3-550 6523
sales.hc@leybold.com
service.hc@leybold.com