

SOGEVAC®

SV40 B - SV65 B - SV100 B

Single-stage, oil-sealed rotary vane pump

Operating instructions 300267596_002_C0

Ref.:

960x00 to 960x07

960x11 to 960x14

960x16 to 960x19

960x20 to 960x24

and their variants



Contents

	Page
Important Safety Information	3
1 Description	5
1.1 Principle of operation	5
1.2 Technical characteristics (valid with standard oil)	6
1.3 Ordering Information	10
1.4 Accessories	13
1.5 Spare parts	15
1.6 Lubricants	15
2 Transport and Storing	16
2.1 Transport and packaging	16
2.2 Mounting orientation	16
2.3 Storing	16
3 Installation	17
3.1 Setting up	17
3.2 Connection to system	17
3.3 Electrical connections	18
3.4 Oil filling	19
3.5 Start-up	19
4 Operation	20
4.1 Operation	20
4.2 Switching off / Shutdown	21
5 Maintenance	22
5.1 Safety Information	22
5.2 Maintenance Intervals	22
5.3 Leybold Service	23
5.4 Maintenance Work	23
6 Troubleshooting	26
7 Spare parts	28
EC Declaration of Conformity	42

Safety Information

Important Safety Information

Indicates procedures that must be strictly observed to prevent hazards to persons.

Indicates procedures that must be strictly observed to prevent damage to, or destruction of the product.

Emphasises additional application information and other useful information provided within these Operating Instructions.

The Leybold Sogevac® SV40 B - SV65 B - SV100 B has been designed for safe and efficient operation when used properly and in accordance with these Operating Instructions. It is the responsibility of the user to carefully read and strictly observe all safety precautions described in this section and throughout the Operating Instructions. The Sogevac® SV40 B - SV65 B - SV100 B **must only be operated in the proper condition and under the conditions described in the Operating Instructions.** It must be operated and maintained by trained personnel only. Consult local, state, and national agencies regarding specific requirements and regulations. Address any further safety, operation and/or maintenance questions to our nearest office.

Failure to observe the following precautions could result in serious personal injury!

Sogevac® pumps are not designed:

- for pumping of dusty, aggressive, corrosive, flammable or explosive gases or gases mixtures,
- for pumping of oxygen with a greater concentration than atmospheric concentration (>20%) or other highly reactive gases
- for working in flammable, explosive or dusty environment.

For all these cases, special materials must be used. In case of doubt, please contact Leybold.

See also the limits of use indicated in the CE declaration of conformity.

Never expose part of the body to the vacuum. There is a danger of injury. Never operate the pump with an open and thus accessible inlet. Vacuum connections as well as oil filling and oil draining openings must not be opened during operation of the pump.

When operating pump is hot and some surfaces could reach a temperature higher than 80 °C (176 °F). There is a risk of burn by touching.

Depending on the process involved, dangerous substances and oil may escape from the pump. Take the necessary safety precautions!

When working on the pump system always observe the Operating Instructions.

Warning

Caution

Note

Warning



Safety Information

Warning



Disconnect the unit from the power supply before starting any work.

Warning



Take appropriate precautions to insure that the pump cannot start.

If the pump has pumped hazardous gases it will be absolutely necessary to determine the nature of the hazard involved and take the appropriate safety precautions.

Observe all safety regulations!

Take adequate safety precautions prior to opening the intake or exhaust port.

Caution

Failure to observe the following precautions could result in damage to the equipment!

Liquid and solid particles must not enter the pump. Install the adequate filters, separators and/or condensers. In case of doubt consult Leybold.

The intake line of the pump must never be connected to a device with over atmospheric pressure. Design the exhaust line so that no pressure higher than 1,15 bar abs. (0,15 bar rel.) can occur.

Operating of the pump without oil or operating with incorrect direction of rotation can destroy the pump.

Note

Never use discarded seals. Always assemble using new seals.

Respect the instructions concerning environment protection when discarding used oil or exhaust filters!

The pump must be packaged in such a way that it will not be damaged during shipping, and so that no harmful substances can escape from the package.

We reserve the right to alter the design or any data given in these Operating Instructions. The illustrations are not binding.

1 Description

Sogevac® pumps are designed for pumping of inert gases in the range of rough vacuum, between atmospheric pressure and ultimate pressure of the pump.

When removing condensable vapours, a gas ballast valve must be installed.

1.1 Principle of operation

The Sogevac® pumps SV40 B, SV65 B and SV100 B are single-stage oil-sealed rotary vane vacuum pumps.

The rotor, having three slots in which the vanes are sliding, is eccentrically installed in a pump cylinder (stator).

The vanes separate the interior space into 3 chambers. The volume of these chambers varies with the rotation of the rotor.

The gas sucked into the inlet chamber is compressed and then pushed out at the exhaust valve.

The oil injected in the inlet chamber guarantees the air-tightness, the lubrication and cooling of the pump. It is dragged off by the compressed gases and roughly separated by gravity when entering in the oil sump. A fine separation is then operated in the exhaust filter, which retains > 99,9 % of the oil aerosols. An internal transfer pushes the collected oil back into the vacuum generator, the transfer is operated by a float valve to avoid atmospheric air coming from the oil casing to the inlet of the pump when no oil is present in the recovery system.

The oil circulation functions by differential pressures. Some pumps are equipped with an oil filter.

Pumps are available with or without gasballast, with corresponding catalog numbers.

At pump switch off, an anti suck-back valve (ASBV) closes the pump inlet and avoids pump oil be sucked into the chamber.

For this, the ASBV must be kept clean and in good condition.

Description

1.2 Technical characteristics (valid with standard oil)

SV40 B

Technical data		50 Hz	60 Hz
Nominal pumping speed	m ³ /h	44	53
Pumping speed (according to PNEUROP)	m ³ /h	38,5	47
Ultimate partial pressure without gas ballast	mbar	≤ 0,5	≤ 0,5
Ultimate total pressure with small gas ballast	mbar	≤ 0,8	≤ 0,8
Ultimate total pressure with standard gas ballast	mbar	≤ 1,5	≤ 1,5
Water vapour tolerance:			
■ with small gas ballast	mbar	10	10
■ with standard gas ballast	mbar	30	30
Water vapour tolerable load:			
■ with small gas ballast	kg.h ⁻¹	0,28	0,34
■ with standard gas ballast	kg.h ⁻¹	0,76	0,90
Noise level (according to DIN 46 635)	dB (A)	58	60
Motor power - Rated rotational speed		see ordering information	
Mains voltage (+/- 10 %) information		see ordering	
Protection - Isolation		IP 55 - F	IP 55 - F
Leak rate	mbar.l.s ⁻¹	1 x 10 ⁻³	1 x 10 ⁻³
Oil Capacity	l	1	1
Intake connection		1 1/4	1 1/4
Exhaust connection		1 1/4	1 1/4

SV65 B

Technical data		50 Hz	60 Hz
Nominal pumping speed	m ³ /h	59	71
Pumping speed (according to PNEUROP)	m ³ /h	54	64
Ultimate partial pressure without gas ballast	mbar	≤ 0,5	≤ 0,5
Ultimate total pressure with small gas ballast	mbar	≤ 0,8	≤ 0,8
Ultimate total pressure with standard gas ballast	mbar	≤ 1,5	≤ 1,5
Water vapour tolerance:			
■ with small gas ballast	mbar	10	10
■ with standard gas ballast	mbar	30	30
Water vapour tolerable load:			
■ with small gas ballast	kg.h ⁻¹	0,36	0,42
■ with standard gas ballast	kg.h ⁻¹	1	1,25
Noise level (according to DIN 46 635)	dB (A)	60	64
Motor power - Rated rotational speed		see ordering information	
Mains voltage (+/- 10 %) information		see ordering information	
Protection - Isolation		IP 55 - F	IP 55 - F
Leak rate	mbar.l.s ⁻¹	1 x 10 ⁻³	1 x 10 ⁻³
Oil Capacity	l	2	2
Intake connection		1 1/4	1 1/4
Exhaust connection		1 1/4	1 1/4

Description

SV40 B - SV65 B

SPACE FOR EXHAUST FILTER EXCHANGE AND COOLING

OIL FILTER (OPTION)

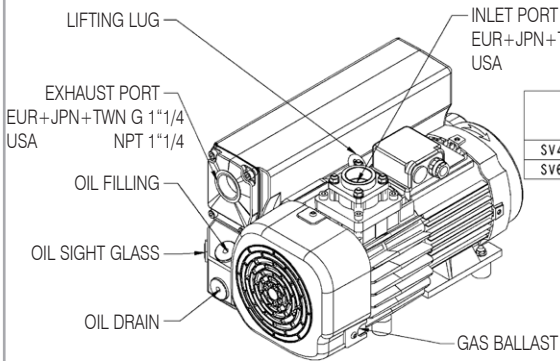
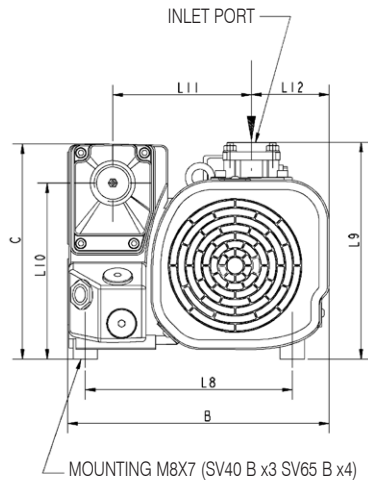
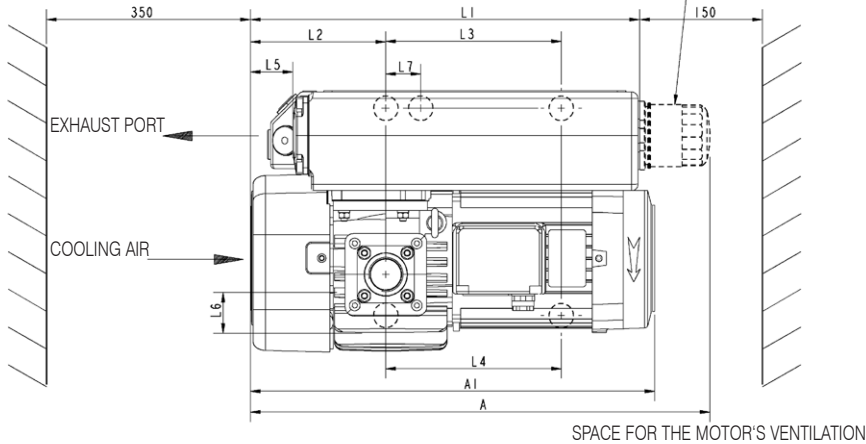

	A	A1	B	C	L1	L2	L3	L4	L5	L6	L7	L8	L9	L10	L11	L12	Weight
SV40 B	510	425	284	265	425	143	-	220	43	46	40	235	255	217	160	74	43 kg
SV65 B	565	480	320	265	480	166	215	215	52	50	0	254	265	217	170	95	49 kg

	A1	L4	Weight
SV40 B US / JPN / TWN	455	226	45 kg
SV65 B US / JPN	480	215	52 kg
SV65 B TWN	480	215	51 kg

+/- 5 mm
+/- 2 kg

Pumping speeds curves SV40 B - SV65 B

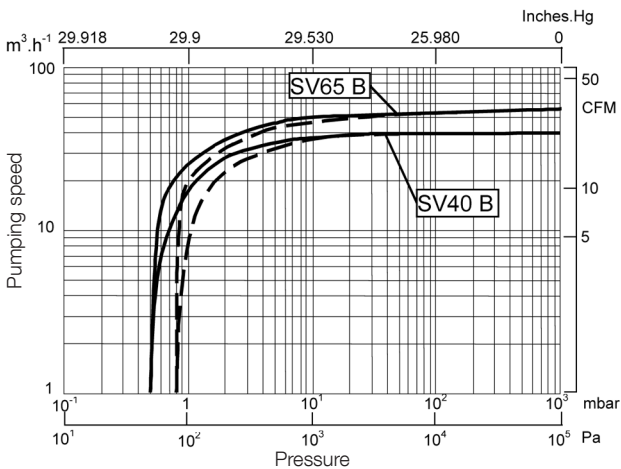

at 50 Hz
Pumping speed (volume flow rate) — Without gas ballast - - - With gas ballast

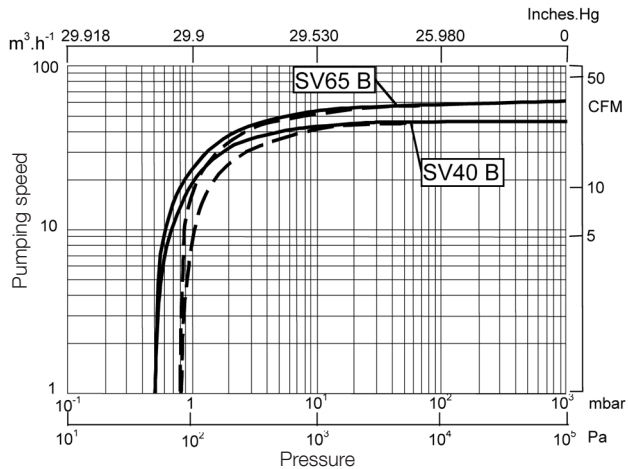

at 60 Hz
Pumping speed (volume flow rate) — Without gas ballast - - - With gas ballast

fig. 1

Description

SV100 B

Technical data (valid with standard oil)		50 Hz	60 Hz
Nominal pumping speed	m ³ /h	97,5	117
Pumping speed (according to PNEUROP)	m ³ /h	87,5	105
Ultimate partial pressure without gas ballast	mbar	≤ 0,5	≤ 0,5
Ultimate total pressure with small gas ballast	mbar	≤ 0,8	≤ 0,8
Ultimate total pressure with standard gas ballast	mbar	≤ 1,5	≤ 1,5
Water vapour tolerance:			
■ with small gas ballast	mbar	10	10
■ with standard gas ballast	mbar	30	30
Water vapour tolerable load:			
■ with small gas ballast	kg.h ⁻¹	0,45	0,60
■ with standard gas ballast	kg.h ⁻¹	1,60	1,70
Noise level (according to DIN 46 635)	dB (A)	61	64
Motor power - Rated rotational speed		see ordering information	
Mains voltage (+/- 10 %) information		see ordering information	
Protection - Isolation		IP 55 - F	IP 55 - F
Leak rate	mbar.l.s ⁻¹	1 x 10 ⁻³	1 x 10 ⁻³
Oil Capacity	l	2	2
Intake connection		1 1/4	1 1/4
Exhaust connection		1 1/4	1 1/4

Description

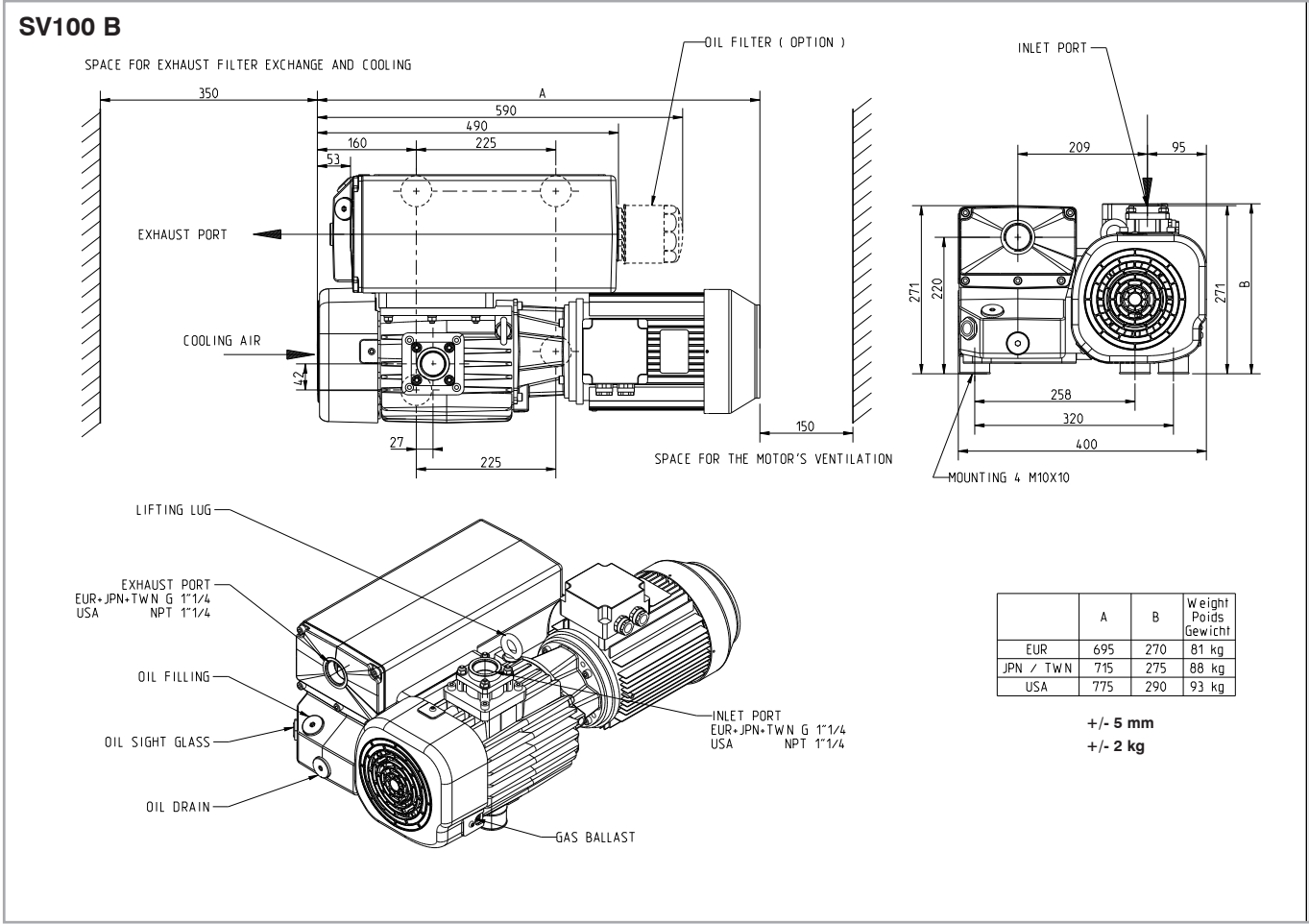

Pumping speeds curves SV100 B

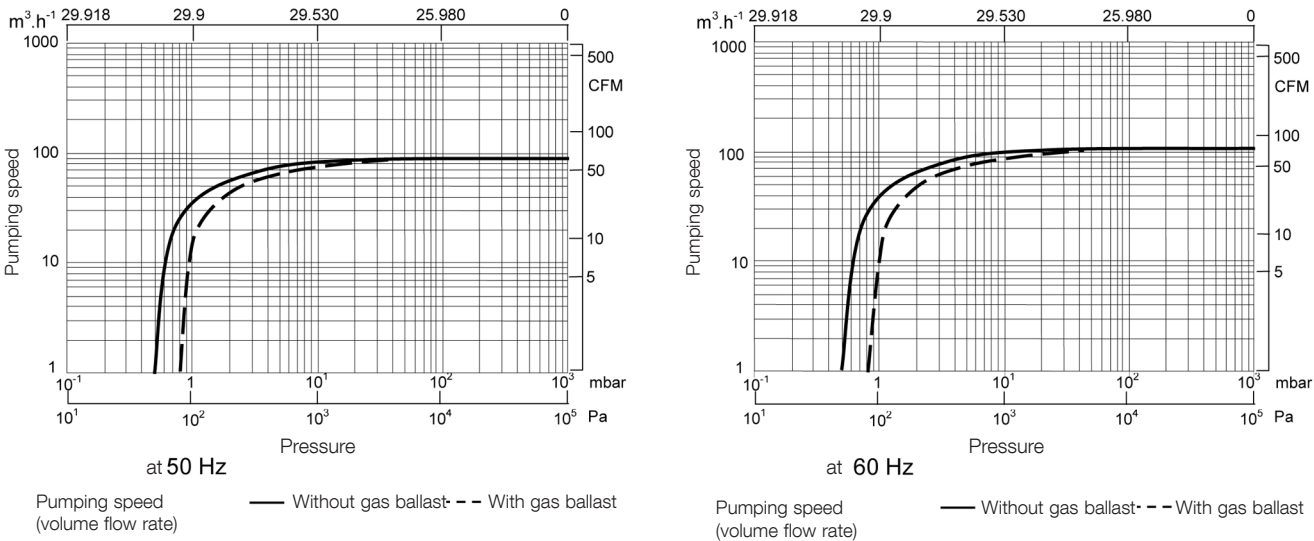

fig. 2

Description

1.3 Ordering Information

SVB 40 m ³ /h					
P/N	Pump	Motor	GB	Oil Filter	Inlet & Exhaust
960300	SV40 B	A	N	N	G 1 1/4
960301	SV40 B	A	Y 1	N	G 1 1/4
960302	SV40 B	A	N	Y	G 1 1/4
960303	SV40 B	A	Y 1	Y	G 1 1/4
960305	SV40 B	A	Y 2	N	G 1 1/4
960307	SV40 B	A	Y 2	Y	G 1 1/4
960311	SV40 B	B	Y 1	N	NPT 1 1/4
960312	SV40 B	B	Y 2	N	NPT 1 1/4
960313	SV40 B	B	Y 1	Y	NPT 1 1/4
960314	SV40 B	B	Y 2	Y	NPT 1 1/4

960316	SV40 B	C	Y 1	N	G 1 1/4
960317	SV40 B	C	Y 2	N	G 1 1/4
960318	SV40 B	C	Y 1	Y	G 1 1/4
960319	SV40 B	C	Y 2	Y	G 1 1/4

960320	SV40 B	D	N	N	G 1 1/4
960321	SV40 B	D	Y 1	N	G 1 1/4
960322	SV40 B	D	Y 2	N	G 1 1/4
960323	SV40 B	D	Y 1	Y	G 1 1/4
960324	SV40 B	D	Y 2	Y	G 1 1/4

Motors :

A = Three phase Euro 230 / 400 V ± 10 %, 50 Hz and 460 V ± 10 %, 60 Hz

B = Three phase USA 230 / 460 V ± 10 %, 60 Hz and 400 V ± 10 %, 50 Hz

C = Three phase Japan 200 V +10 % - 15 %, 50/60 Hz

D = Three phase 210 - 240 & 360 - 420 V ± 5%, 50 Hz & 210 - 260 & 360 - 460 V ± 5%, 60 Hz

GB Y1 = 0,8 m³/h

GB Y2 = 2 m³/h

GB Y3 = 4 m³/h

Description

SVB 65 m ³ /h					
P/N	Pump	Motor	GB	Oil Filter	Inlet & Exhaust
960400	SV65 B	A	N	N	G 1 1/4
960401	SV65 B	A	Y 1	N	G 1 1/4
960402	SV65 B	A	N	Y	G 1 1/4
960403	SV65 B	A	Y 1	Y	G 1 1/4
960405	SV65 B	A	Y 2	N	G 1 1/4
960407	SV65 B	A	Y 2	Y	G 1 1/4
960411	SV65 B	B	Y 1	N	NPT 1 1/4
960412	SV65 B	B	Y 2	N	NPT 1 1/4
960413	SV65 B	B	Y 1	Y	NPT 1 1/4
960414	SV65 B	B	Y 2	Y	NPT 1 1/4
960416	SV65 B	C	Y 1	N	G 1 1/4
960417	SV65 B	C	Y 2	N	G 1 1/4
960418	SV65 B	C	Y 1	Y	G 1 1/4
960419	SV65 B	C	Y 2	Y	G 1 1/4
960420	SV65 B	D	N	N	G 1 1/4
960421	SV65 B	D	Y 1	N	G 1 1/4
960422	SV65 B	D	Y 2	N	G 1 1/4
960423	SV65 B	D	Y 1	Y	G 1 1/4
960424	SV65 B	D	Y 2	Y	G 1 1/4

Motors :

A = Three phase Euro 230 / 400 V ± 10 %, 50 Hz and 460 V ± 10 %, 60 Hz

B = Three phase USA 230 / 460 V ± 10 %, 60 Hz and 400 V ± 10 %, 50 Hz

C = Three phase Japan 200 V +10 % - 15 %, 50/60 Hz

D = Three phase 210 - 240 & 360 - 420 V ± 5%, 50 Hz & 210 - 260 & 360 - 460 V ± 5%, 60 Hz

GB Y1 = 0,8 m³/h

GB Y2 = 3,5 m³/h

GB Y3 = 5 m³/h

Description

SVB 100 m ³ /h					
P/N	Pump	Motor	GB	Oil Filter	Inlet & Exhaust
960500	SV100 B	A	N	N	G 1 1/4
960501	SV100 B	A	Y 1	N	G 1 1/4
960502	SV100 B	A	N	Y	G 1 1/4
960503	SV100 B	A	Y 1	Y	G 1 1/4
960505	SV100 B	A	Y 2	N	G 1 1/4
960507	SV100 B	A	Y 2	Y	G 1 1/4
960511	SV100 B	B	Y 1	N	NPT 1 1/4
960512	SV100 B	B	Y 2	N	NPT 1 1/4
960513	SV100 B	B	Y 1	Y	NPT 1 1/4
960514	SV100 B	B	Y 2	Y	NPT 1 1/4

960516	SV100 B	C	Y 1	N	G 1 1/4
960517	SV100 B	C	Y 2	N	G 1 1/4
960518	SV100 B	C	Y 1	Y	G 1 1/4
960519	SV100 B	C	Y 2	Y	G 1 1/4

960521	SV100 B	D	Y 1	N	G 1 1/4
960522	SV100 B	D	Y 2	N	G 1 1/4
960523	SV100 B	D	Y 1	Y	G 1 1/4
960524	SV100 B	D	Y 2	Y	G 1 1/4

Motors :

A = Three phase Euro 230 / 400 V \pm 10 %, 50 Hz and 460 V \pm 10 %, 60 Hz

B = Three phase USA 230 / 460 V \pm 10 %, 60 Hz and 400 V \pm 10 %, 50 Hz

C = Three phase Japan 200 V +10 % - 15 %, 50/60 Hz

D = Three phase wide range 230 & 400 V \pm 10%, 50 Hz & 230 & 400 & 460 V \pm 10%, 60 Hz

GB Y1 = 1,5 m³/h

GB Y2 = 4 m³/h

GB Y3 = 7 m³/h

1.4 Accessories

Item	Specification	Size	Cat. Nr.
1	Union coupling	G1 1/4 M/F	711 18 023
2	Nipple	G1 1/4 M/M	711 18 033
3	Ball valve	G1 1/4 F-F	711 30 105
4	Threaded flange adapter	G1 1/4 M - 40KF	711 18 123
5	Centering ring	40KF	18 328
6	Clamping ring	40KF	18 343
7	Adapter for tubing	G1 1/4 M-DN40	711 18 013
8	Rubber vacuum tubing	Ø10X25	17 203
9	Adapter for tubing	G1 1/4-Ø10X25	711 18 153
10	Adapter	40KF-DN40	711 18 303
11	PVC tubing	DN40 - 1m.	711 18 324
12	TEE reducer bush	G1 1/4 - 1/2 7	711 18 263
13	Right-angle bend 90°	G1 1/4 F-F 7	711 18 213
14	Dust filter paper F40	G1 1/4 M-F	95 155
	Dust filter charcoal F40	G1 1/4 M-F	711 27 102
	Dust filter metal F40	G1 1/4 M-F	711 27 103
	Dust filter polyester F40	G1 1/4 M-F	711 27 104
	Dust filter paper F65-100	G1 1/4 M-F	95 160
	Dust filter charcoal F65-100	G1 1/4 M-F	711 27 112
	Dust filter metal F65-100	G1 1/4 M-F	711 27 113
	Dust filter polyester F65-100	G1 1/4 M-F	711 27 114
15	Vacuum gauge	G1/2 M	95 192
16	Ball valve	G1/2 M/F DN13	711 30 113
17	Threaded flange adapter	G1/2 M - 16KF	711 18 120
18	Regulation valve with isolation valve	G1/2 M	95 187
19	Regulation valve	G1/2 M	95 186
20	Condensate trap SL40	G1 1/4	95 140
21	Condensate trap SL65-100	G1 1/4	95 142

Description

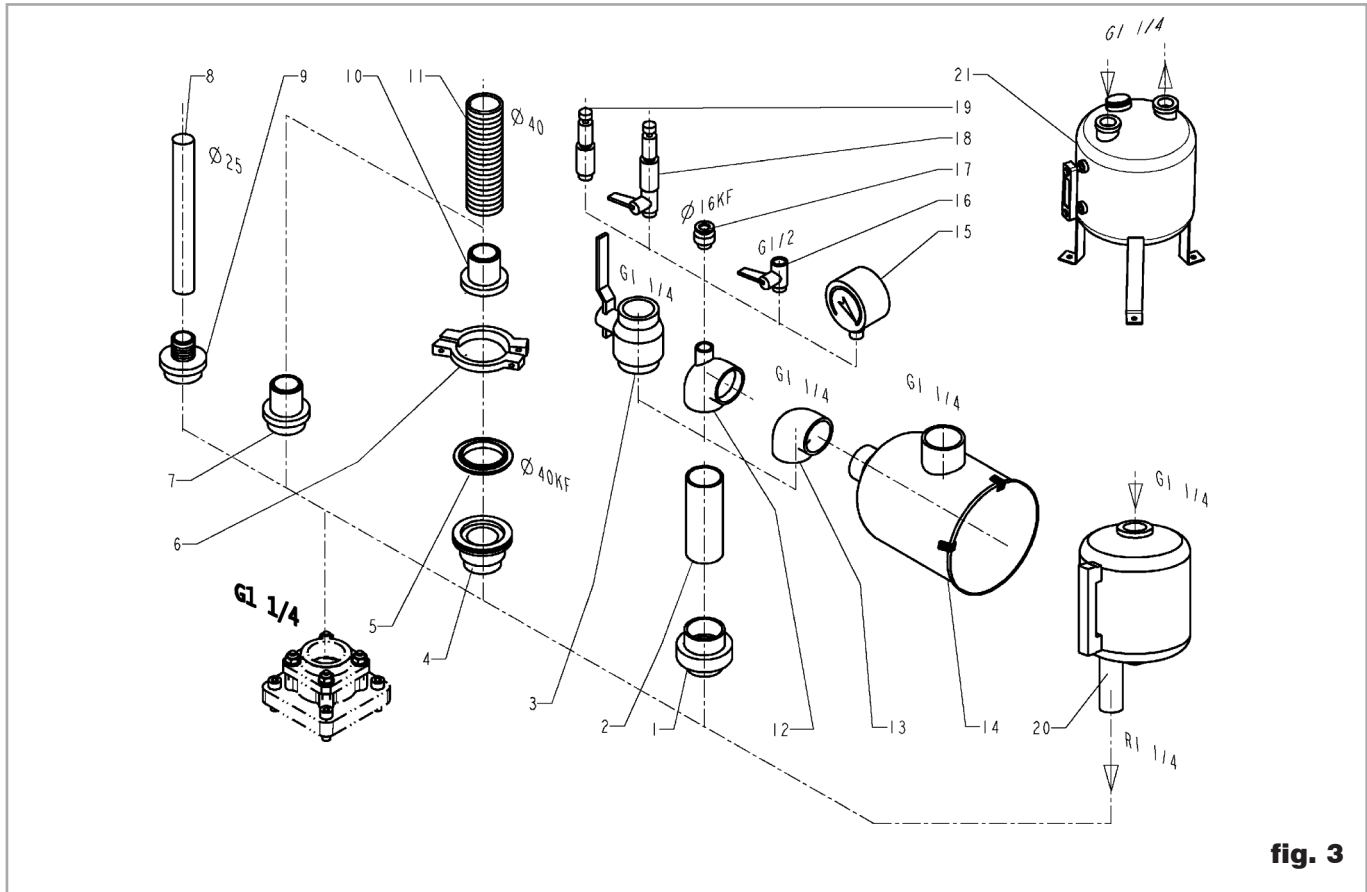

fig. 3

	SV40 B	SV65 B	SV100 B
Specification	Cat. Nr.	Cat. Nr.	Cat. Nr.
Oil level switch	711 19 110	711 19 110	711 19 110
Temperature switch		upon request	
Exhaust filter over pressure switch	9 714 25 890	9 714 25 890	9 714 25 890
Exhaust filter over pressure manometer	95 194	95 194	95 194
Oil drain tap	711 30 114	711 30 114	711 30 114
Roots adapter			9 714 48 740
Oil filter*	714 20 980	714 20 980	712 13 150
Oil filter bypass*	712 30 570	712 30 570	712 30 570

* depends of pump Cat-Nr.

1.5 Spare parts

		SV40 B	SV65 B	SV100 B
Specification	Size	Cat. Nr.	Cat. Nr.	Cat. Nr.
Set of seals	FKM	9 714 27 640	714 20 410	9 714 27 670
Repair set		9 714 27 650	714 20 420	9 714 27 680
Vacuum generator without GB		9 714 28 210	714 22 080	7 714 27 740
Vacuum generator with GB		9 714 28 220	9 714 23 430	9 714 27 750
Service kit		9 714 27 660	9 714 23 440	9 714 27 690
Inlet filter element				
■ paper		710 46 118	712 13 283	712 13 283
■ metal		710 49 083	E 712 13 324	E 712 13 324
■ charcoal		710 49 103	E 712 13 304	E 712 13 304
■ polyester		712 61 298	712 61 300	712 61 300

1.6 Lubricants

The Sogevac® pumps should be run with mineral oils for vacuum pumps with low viscosity according to ISO category VG77. The Leybold oil fulfills these specifications.

LVO130 oil:	Conditioning	Reference
	2 l	711 17 773 / L13002
	5 l	711 17 774 / L13005
	20 l	711 17 775 / L13020
	200 l	711 17 779 / L13099

You may use other special lubricants adapted to the applications. Please consult us.

Use the oil type indicated on the pump and in the additional operating instructions. In case other oils are used, Leybold is not liable and declines warranty claims.

Transport and storing

2 Transport and Storing

2.1 Transport and packaging

Sogevac® vacuum pumps pass a rigorous operating test in our factory and are packaged to avoid transport damages.

Please check packaging on delivery for transport damages.

Packing materials should be disposed off according to environmental laws or re-cycled. These operating instructions are part of the consignment.

The connection ports are blanked off by plastic protective caps or self-adhesives. Take these caps or self-adhesives away before turning on the pump.

For SV40 B and SV65 B, the necessary oil is supplied in a can beside the pump. For the SV100 B, the oil is filled in.

2.2 Mounting orientation

See required space on drawings in paragraph 1.2.

Pumps which have been filled with oil must only be moved in the upright position (horizontally). Otherwise oil may escape. The angle of slope may not be over 10° max. Avoid any other orientations while moving the pump.

Only use the lifting lugs which are provided on the pump to lift the pump with the specified lifting devices.

Use only lifting devices appropriated to the pump weight. Check name plate. Do not use other pump elements than the lifting lugs as handles.

Make sure that these have been installed safety. Use suitable lifting equipment. Make sure that all safety regulations are observed.

2.3 Storing

Before stocking the pump for a long time put it back in its original condition (blank off inlet and exhaust ports with the shipping seals, drain the oil) and store the pump in a dry place at room temperature.

Until the pump is put back in to service again, the pump should be stored in a dry place, preferably at room temperature (20 °C - 168 °F). Before taking the pump out of service, it should be properly disconnected from the vacuum system, purged with dry nitrogen and the oil should be exchange too. The gas ballast must be closed and if the pump is to be shelved for a longer period of time is should be sealed in a plastic bag together with a desiccant (Silicagel).

If the pump has been shelved for over one year, standard maintenance must be done and the oil must be exchanged too before the pump is put in to service once more.

We recommend that you contact the service from Leybold.

Caution

3 Installation

It is essential to observe the following instructions step by step to ensure safe start-up. Start-up may only be conducted by trained specialists.

The standard pump is not suitable for installation in explosion hazard areas ATEX. Please contact us, if you are planning such an application. Before installing the pump you must reliably disconnect it from the electrical power supply and prevent the pump from running up inadvertently.

Observe all safety regulations.

3.1 Setting up

The pump must be set up or mounted horizontally on a flat surface. Special mounting is not required. For indoor use only up to 1000 m altitude.

The following ambient operating environment must be observed:

- Ambient temperature: 12 °C to 40 °C (54 °F to 104 °F),
- Rel. humidity (without condensation) \leq 95 %
- Ambient pressure = Atmospheric pressure.

In order to avoid over-heating of the pump, an undisturbed fresh airflow to the pump is necessary.

The pump must be kept clean (no dust deposit)

3.2 Connection to system

Inlet connection

See safety instructions page 3.

- The inlet flange can be connected with a vacuum-tight flexible hose and/or pipe. The pipes should cause no stresses on the pump's flanges. If necessary, compensators must be installed.
- Restriction of the pipes must be avoided in order not to decrease the pumping speed of the pump. The nominal diameter of the pipes has to be at least the same as the diameter of pump's inlet flange.
- When removing condensable vapours, a gas ballast valve must be installed.
- Inlet pressure must not exceed atmospheric pressure.

Connection to exhaust side

- No isolation or restricting devices should be installed in the exhaust line of the pump. If an exhaust line is installed, it must at least have the same diameter as the exhaust flange. It should be installed in a manner so that no condensate can enter the pump (siphon, slope).

The maximum exhaust pressure must neither exceed 1.15 bar absolute (0.15 bar relative), nor fall under atmosphere pressure minus 15 mbar.

Pump exhaust to be connected if oil mist or process gases are to be avoided in the pump area.

Corresponding pressure regulating devices to be installed by the user.

Warning



Caution

Warning



Installation

3.3 Electrical connections

Ensure that incoming power to the pump is off before wiring the motor or altering the wiring.

Warning



Electrical connection work must only be carried out by a qualified electrician in accordance with the applicable safety rules, see IEC 60204-1 & IEC 61010-1.

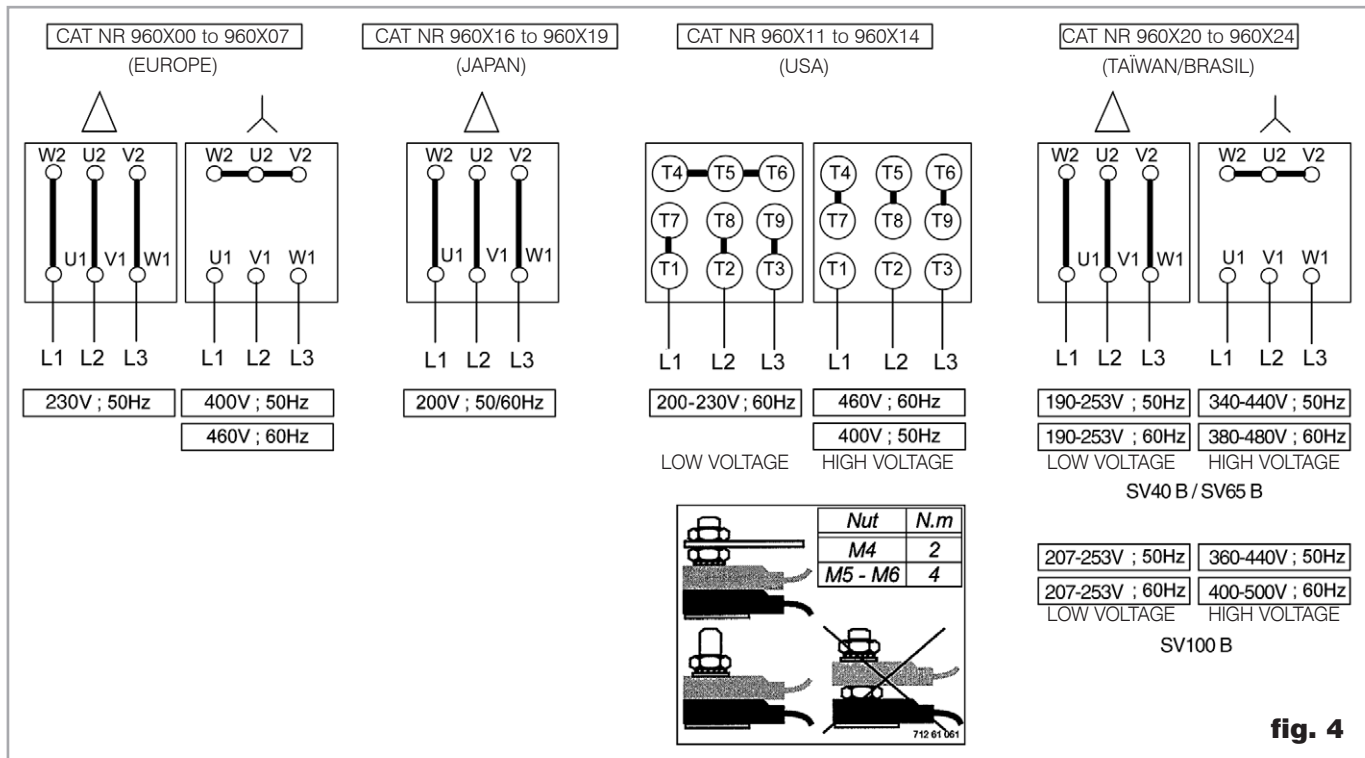

fig. 4

Voltage and frequency mentioned on the motor nameplate must agree with the supply voltage.

To check the direction of rotation of pumps, flick the ON/OFF switch. If the direction of rotation is not identical with the one indicated by the arrow sticking on the motor hood, then inverse any two of the electrical phases in the terminal box. Looking at the motor fan cover, the direction of rotation has to be counterclockwise.

3.4 Oil filling

For SV40 B and SV65 B, the necessary oil is supplied in a can beside the pump.

For the SV100 B, the oil is filled in.

To fill in the oil, unscrew the oil fill plug (48 for SV40 B and SV65 B, 52 for SV100 B) and fill in until the oil level reaches the "MAX" mark beside the oil sight glass.

3.5 Start-up

The pumps are supplied with the necessary oil filling in ready-to-use condition. Always verify proper oil level before operating the pump.

The pump is designed for fail-safe start-up at temperatures over 12 °C (55 °F) (as per PNEUROP).

If local regulations provide a WYE-DELTA starting connect the pump to the system so that it can start loadfree, i.e. at atmospheric pressure in the intake port. If the vacuum system is not to be vented further measures will be necessary, e.g. a starting valve can be mounted.

Please contact us in this case.

The signals of the oil level switch and exhaust filter over pressure switch must be delayed (timer) on the pump switch-on for approx. 1 minute.

Caution

Caution

Operation

4 Operation

4.1 Operation

To avoid overloading the motor, do not start the pump more than 6 times within one hour. If more than 6 starts per hour are necessary keep the pump running and mount a valve which opens and closes into the intake line.

Take note of warning labels on the pump.

Use ear protection in case of operation at high inlet pressures

Warning



Pumping of non-condensable gases

If the pump system contains mainly non condensable gases, the pumps should be operated without gas ballast.

If the composition of the gases to be pumped is not known and if condensation in the pump cannot be ruled out, run the pump with gas ballast valve open in accordance with section below.

Pumping of condensable gases and vapors

With the gas ballast valve open and at operating temperature, the Sogevac® pumps can pump pure water vapor up to the values indicated in the Technical Data.

The gas ballast valve is opened by a screwdriver. The running noise of the pump is slightly louder if the gas ballast valve is open. Before pumping vapors ensure that the pump has warmed up for approx. 30 min. with closed intake line and with open gas ballast valve.

Caution

Don't open the pump to condensable vapors until it has warmed to operating temperature; pumping process gas with a cold pump results in vapors condensing in the oil.

For processes with a high proportion of condensable vapors, the intake line should be opened only slowly after reaching the operating temperature.

One sign of condensation of vapors in the pump is a rise of the oil level during operation of the pump.

Caution

When vapors are pumped, the pump must not be switched off immediately after completion of the process because the condensate dissolved in the pump oil may cause changes or corrosion. To prevent this, the pump must continue to operate with open gas ballast valve and closed intake port until the oil is free of condensate. We recommend operating the pump in this mode for at least 30 min. after completion of the process.

Note

In cycle operation, the pump should not be switched off between the cycles but should continue to run with gas ballast valve open and intake port closed (if possible via a valve). Power consumption is minimal when the pump is operating at ultimate pressure.

Once all vapors have been pumped off from a process (e. g. during drying), the gas ballast valve can be closed in order to improve the ultimate pressure.

4.2 Switching off / Shutdown

The intake port of the Sogevac® pumps contains an anti-suckback valve which closes the intake port when the pump is switched off, thus maintaining the vacuum in the connected apparatus and preventing oil from being sucked back into the apparatus. The valve's functioning is not impaired by gas ballast operation, but must be kept clean.

Nevertheless, the anti suck-back valve is not a safety device and it is recommended to install a pilot valve. The anti suck-back must be kept clean and in good condition to remain tight.

If the pump has to be shutdown, drain the oil flush out the pump with fresh oil and fill in the required amount of clean oil (see § 5.4). Close the connection ports. Special preservation or flushing oils do not need to be used.

When the pump has been switched off due to over heating, initiated by the motor protection, the pump must be cooled down to the ambient temperature, and must only be switched on again manually after having eliminated the cause.

In order to prevent the pump from running up unexpectedly after a mains power failure, the pump must be integrated in to the control system in such a way that the pump can only be started by a manually operated switch. This applies equally to emergency cut-off switches.

Caution

Maintenance

Warning



Caution

5 Maintenance

5.1 Safety Information

Observe all safety regulations.

All work must be done by suitably trained personnel. Maintenance or repairs carried out incorrectly will affect the life and performance of the pump and may cause problems when filing warranty claims.

Never mount used seals; always mount new seals.

5.2 Maintenance Intervals

The intervals stated in the maintenance schedule are approximate values for normal pump operation. Unfavourable ambient conditions and/or aggressive media may significantly reduce the maintenance intervals.

Maintenance job	Frequency	Section
Check the oil level	Daily	A
1st oil change	After 150 h of operation	B
Subsequent oil changes	Every 2000 h or 6 months (depending on application)	B
Replace the oil filter	At each oil change	B
Replace the exhaust filter	If oil mist at exhaust or annually	C
Gas ballast	Monthly	D
Clean the dirt trap	6 months	E
Check the anti-suckback valve	6 months	F
Fan cover cleaning	6 months	G
Electrical connections (only by a specialist)	6 months	

To simplify the maintenance work we recommend combining several jobs.

Contamination

Formulaire

5.3 Leybold Service

Whenever you send us in equipment, indicate whether the equipment is contaminated or is free of substances which could pose a health hazard. If it is contaminated, specify exactly which substances are involved. You must use the form we have prepared for this purpose.

A copy of the form has been reproduced at the end of these Operating Instructions: "Declaration of Contamination for Compressors, Vacuum Pumps and Components". Another suitable form is available from www.leybold.com → Documentation → Download Documents.

Attach the form to the equipment or enclose it with the equipment.

This statement detailing the type of contamination is required to satisfy legal requirements and for the protection of our employees.

We must return to the sender any equipment which is not accompanied by a contamination statement.

The pump must be packaged in such a way that it will not be damaged during shipping, and so that no harmful substances can escape from the package.

When disposing of used oil, please observe the relevant environmental regulations.

Caution

5.4 Maintenance Work

Checking the oil

A. Oil level

The pump's oil level during operation must always be between the middle and top edge of the oil-level glass.

When necessary, switch off the pump and add the correct quantity of oil.

High oil consumption often indicates that exhaust filters are clogged.

The oil level should be checked at least once a day.

B. Oil Change, Replacing the Oil Filter (if installed)

Tool required:

- oil filter key (Ref. No. 710 73 532)

Always change the oil when the pump is switched off but still at working temperature.

If there is a risk of the oil being polymerized by the connected process, change the oil immediately after operation of the pump.

Pump when operating is hot and some surfaces could reach a temperature higher than 80 °C (176 °F).

There is a risk of burn by touching. Take note of the warning labels on the pump.

Warning



Maintenance

Unscrew the oil-drain plug and let the used oil drain into a suitable container.

Observe the safety regulations!

When the flow of oil slows down, screw the oil drain plug back in, briefly switch on the pump (max. 10s) and switch it off. Remove the oil drain plug again and drain the remaining oil.

Unscrew the oil filter. Take a new oil filter, moisten its gasket with oil and screw it in manually.

Reinsert the oil-drain plug.

Unscrew the oil-fill plug and fill the pump with fresh oil up to the bottom edge of the oil level glass, run the pump for a short time and then change the oil again.

Caution

Warning



Note

Use suitable oil only (see Section 1.8).

Depending on the process involved dangerous substances may escape from the pump and oil. Take the appropriate precautions.

Observe the safety regulations.

Never mount used seals. Always mount new seals.

When disposing of used oil please observe the relevant environmental regulations!

C. Replacing the exhaust filters

When the exhaust filter elements are clogged, the integrated by-pass opens and the filters are bypassed. Oil mist at the exhaust, and/or high oil consumption are signs that the exhaust filters are clogged.

The exhaust filters must be replaced more often if subjected to increased oil cracking products at high operating temperatures and/or aggressive media.

Oil mist escaping from the exhaust during operation indicates that the filter is probably clogged. Increased energy intake by the motor could also be the result of a soiled exhaust filter.

Open the exhaust hood, take out the filter and replace it.

Also check the gasket of the exhaust flange and change it if necessary.

Note

When disposing of used oil please observe the relevant environmental regulations!

D. Gas ballast valve cleaning

To clean the gas ballast valve, disassemble the fan cover and the fan. Unscrew the lateral pressure screw, remove the plug and the gas ballast valve by using an appropriate M10 screw screwed in the valve by pulling on the screw.

Clean the membrane, the seat and the RILSAN tube.

Reassemble in the reverse sequence.

E. Inlet flange sifter cleaning

To clean the inlet flange sifter, disconnect the inlet flange and clean the sifter with blast air or an appropriate solvent.

F. Anti-suck back valve checking

The anti-suck back valve should be checked at the same time as the inlet flange sifter and if dirty, be cleaned with an appropriate solvent.

Also check, if there is no damage on the sealing part of the valve.

G. Fan cover cleaning

Soiling of the fan cover may lead to overheating of the motor and the pump.

Put off the cover and clean it with blast air.

Before starting the pump again, be sure that the cover has been reassembled.

H. Checking the float valve

When replacing the exhaust filter, check the cleanliness and the proper operation of the float valve.

After having disassembled the exhaust flange, remove the centering pin, pull on the float valve, clean the nozzle and check that the float itself oscillates free around its axle and that the valve is tight.

Clean the float chamber of the oil casing.

Reassemble in the reverse sequence.

Troubleshooting

6 Troubleshooting

Fault	Possible cause	Remedy	Reference section *
Pump does not start.	Pump is connected incorrectly.	Connect the pump correctly.	3.3
	Motor protection switch incorrectly set.	Set motor protection switch properly.	3.3
	Operating voltage does not match motor.	Replace the motor.	
	Motor is malfunctioning.	Replace the motor.	
	Oil temperature is below 12 °C (54 °F).	Heat the pump and pump oil or use different oil.	1.8
Pump does not reach ultimate pressure.	Oil is too viscous.	Use appropriate oil grade.	5.4-B
	Exhaust filter / exhaust line is clogged.	Replace the filter or clean the exhaust line.	3.4-C
	External leak.	Repair the pump.	
	Float valve does not close.	Repair the valve.	5.4-H
	Anti-suckback valve is malfunctioning.	Repair the valve.	5.4-F
	Inadequate lubrication due to:	Change the oil (degas it, if necessary).	5.4-B
	<ul style="list-style-type: none"> ■ unsuitable or contaminated oil, ■ clogged oil filter, ■ clogged oil lines. ■ Vacuum lines are dirty. ■ Pump is too small. 	Replace the oil filter.	5.4-B
Pumping speed is too low.	Dirt trap in the intake port is clogged.	Clean the dirt trap; Precaution: install a dust filter in intake line.	5.4-E/1.2/3.2
	Exhaust or inlet filter is clogged.	Install new filter elements.	5.4-C
	Connecting lines are too narrow or too long.	Use adequately wide and short connecting lines.	3.2
	Anti-suckback valve is hard to open.	Check spring free length.	
After switching off pump under vacuum, pressure in system rises too fast.	System has a leak.	Check the system.	
	Anti-suckback is malfunctioning.	Repair the valve.	5.4-F
Pump gets too hot.	Cooling air supply is obstructed.	Set pump up correctly.	3.1
	Cooler is dirty.	Clean the cooler.	
	Ambient temperature is too high.	Set pump up correctly.	3.1
	Process gas is too hot.	Change the process.	
	Oil level is too low.	Add oil to reach the correct oil level.	5.4-B
	Oil is unsuitable.	Change the oil.	5.4-B
	Oil cycle is obstructed.	Clean or repair the oil lines.	
Exhaust filter / exhaust line is obstructed.	Exhaust filter / exhaust line is obstructed.	Replace the exhaust filter, clean the exhaust line.	5.4-C

Troubleshooting

Fault	Possible cause	Remedy	Reference section *
Oil in intake line or in vacuum vessel.	Oil comes from the vacuum system.	Check the vacuum system.	
	Anti-suckback valve is obstructed.	Clean or repair the valve.	5.4-F
	Sealing surfaces of anti-suckback valve are damaged or dirty.	Clean or repair the intake port and valve.	5.4-F
	Oil level is too high.	Drain the excess oil.	5.4-B
Pump's oil consumption too high, oil mist at exhaust.	Exhaust filters are clogged or damaged.	Replace the filters.	5.4-C
	Nozzle of float valve is clogged.	Check the valve, clean the nozzle.	5.4-I
	Oil level is too high.	Drain the excess oil.	5.4-B
Oil is turbid.	Condensation.	Degas the oil or change the oil and clean the pump.	4.1/5.4-B
		Precaution: open the gas ballast valve or insert a condensate trap.	
		Clean the gas ballast intake filter.	5.4-G
Pump is excessively noisy.	Oil level is very low (oil is no longer visible).	Add oil.	5.4-B
	Oil filter is clogged.	Change the oil and filter.	5.4-B
	Large vacuum leak in system.	Repair vacuum leak.	Contact Leybold.

* Reference section: This column refers to the section in the Operating Instructions that contains the applicable repair information.

Never mount used seals. Always mount new seals.

Spare parts

7 Spare parts

To guarantee safe operation of the Leybold vacuum pump, only original spare parts and accessories should be used. When ordering spare parts and accessories, always state pump type and serial number. You can find part numbers in the spare parts list.

Consummables and main spare parts kits for Sogevac® pumps are usually available on stock at Leybold's service centers. The list of these parts is given here after and in the spare parts table where the contents of each kits is detailed.

- Oil filter (on some models)
- Exhaust demisters
- Oil (Special oils please refer to the specific notice of the pump or contact Leybold)
- Service kit
- Set of seals
- Repair kit
- Vacuum generator without GB
- Vacuum generator with GB

We recommend to use these kits which have been defined to allow an optimal maintenance or repair. Individual spare parts may need longer delivery time.

SV40 B

ERSATZTEILLISTE / SPARE PARTS LIST / LISTE DES PIECES DE RECHANGE SOGEVAC SV40 B

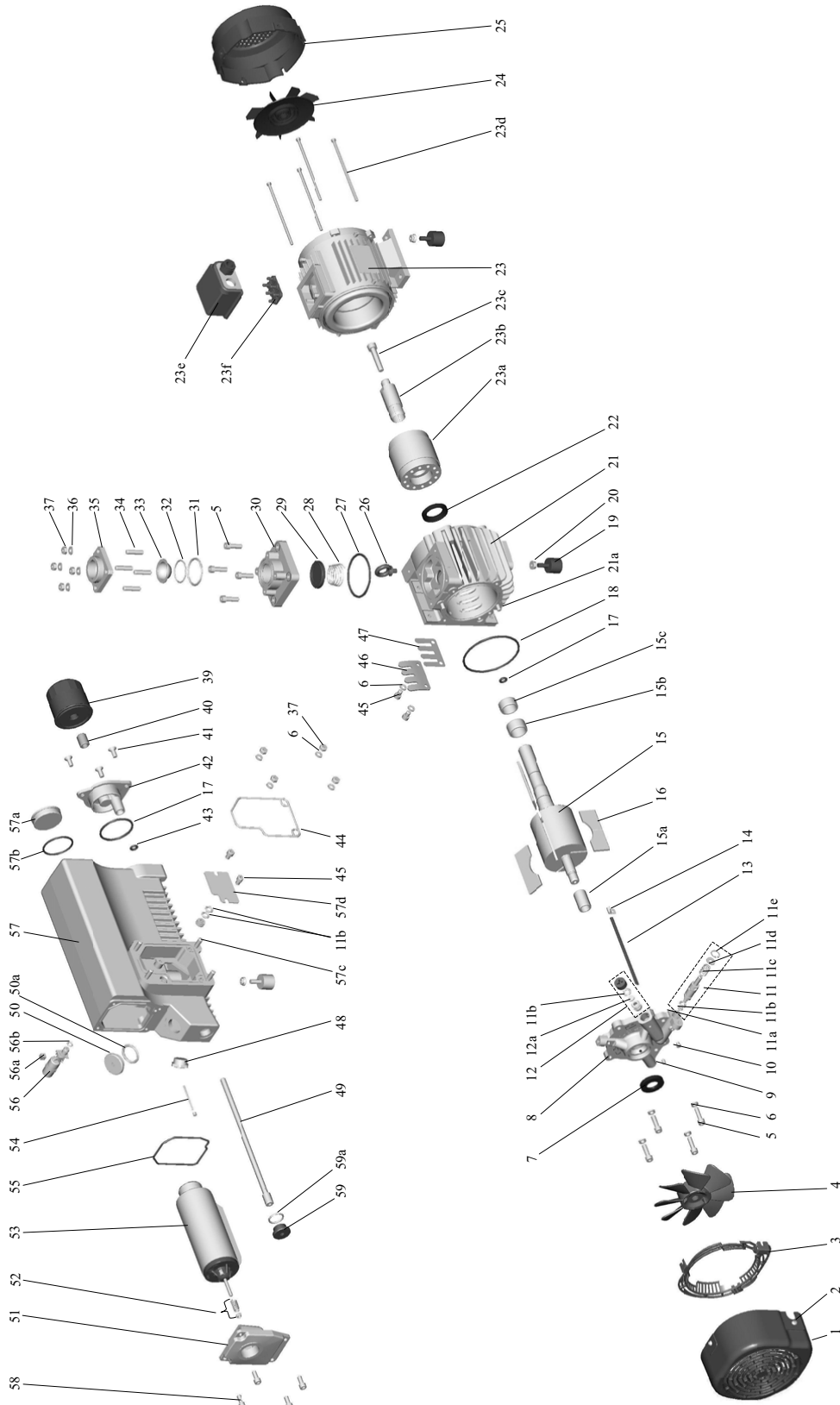

fig. 5

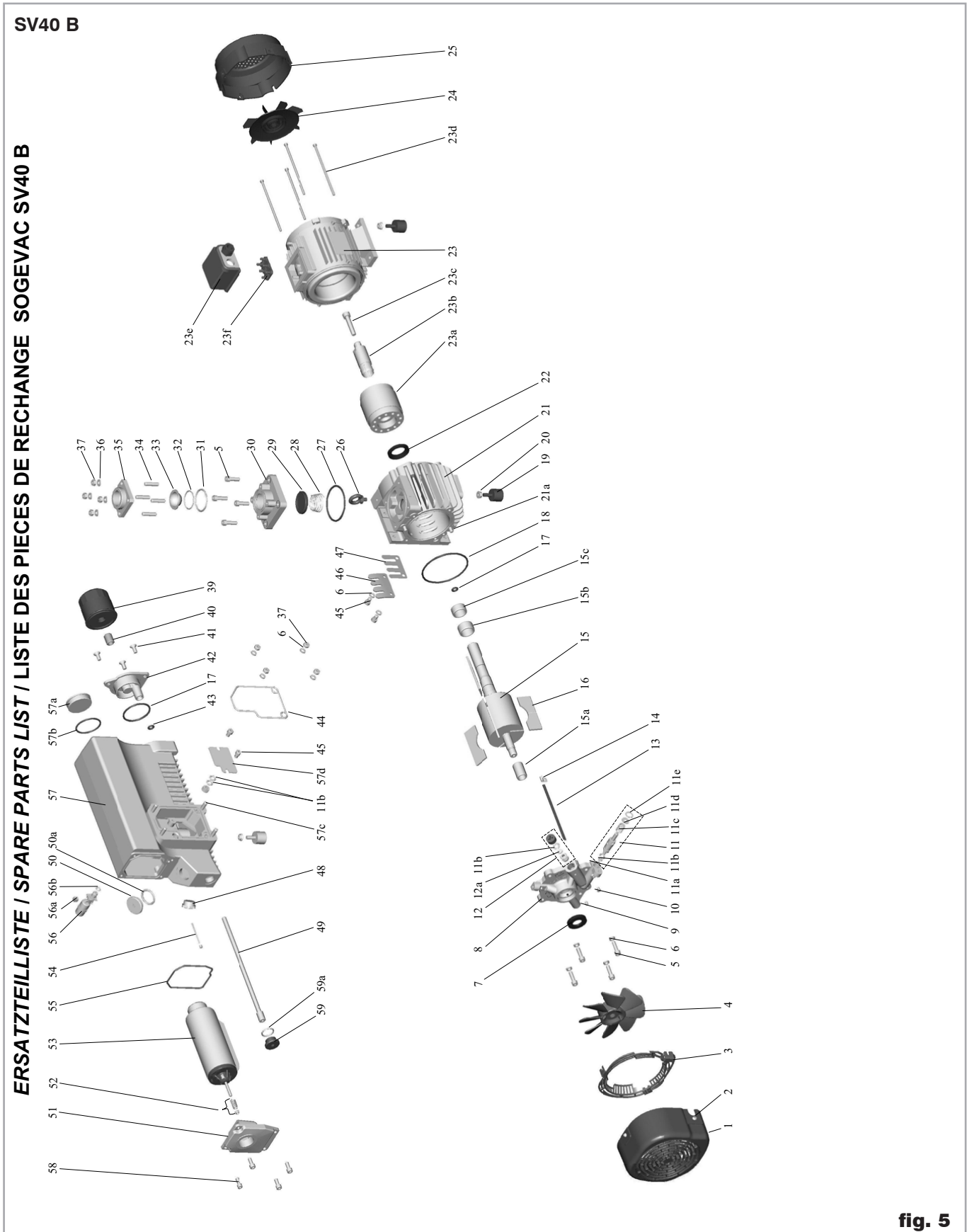

fig. 5

Spare parts

Pos.	Qty	SPECIFICATION	Dimensions (mm), Material	Ref, No,	Notes					
23	1	MOTOR	1.1KW 50HZ 230/400V	71421130	Incl.23a,b,c,d,e,f,24,25					
23a	1	ELECTRICAL ROTOR		971424230						
23b	1	MOTOR RING		71421150						
23c	1	SCREW	CHC M10							
23d	1	TIE ROD (SET OF 4)		71420560						
23e	1	TERMINAL BOX		971422840						
23f	1	TERMINAL BOARD		971422860						
23	1	MOTOR	2 HP 60HZ 230/460V	71421160	Incl.23a,b,c,d,e,f,24,25					
23a	1	ELECTRICAL ROTOR		971424240						
23b	1	MOTOR RING		71421140						
23c	1	SCREW	CHC M10							
23d	1	TIE ROD (SET OF 4)		71416800						
23e	1	TERMINAL BOX		971422900						
23	1	MOTOR	1.5 KW 50/60HZ 200V	71421250	Incl.23a,b,c,d,e,f,24,25					
23a	1	ELECTRICAL ROTOR		971424240						
23b	1	MOTOR RING		71421140						
23c	1	SCREW	CHC M10							
23d	1	TIE ROD (SET OF 4)		71416800						
23e	1	TERMINAL BOX		971422840						
23f	1	TERMINAL BOARD		971422860						
23	1	MOTOR	1.3 KW 50/60HZ 230/400V	71421240	Incl.23a,b,c,d,e,f,24,25					
23a	1	ELECTRICAL ROTOR		971424240						
23b	1	MOTOR RING		71421140						
23c	1	SCREW	CHC M10							
23d	1	TIE ROD (SET OF 4)		71416800						
23e	1	TERMINAL BOX		971422840						
23f	1	TERMINAL BOARD		971422860						

Spare parts

Pos.	Qty	SPECIFICATION	Dimensions (mm), Material	Ref. No.	Notes					
1	1	MODULE COVER		71417020	Incl. 2					
2	3	SCREW	M6							
4	1	TURBINE		71417080	Incl.4a					
4a	1	SCREW	M6	71257660						
5	8	SCREW	M8					X	X	
6	10	WASHER	W8						X	X
7	1	RADIAL SHAFT SEAL	FKM	71417570		X			X	X
8	1	END PLATE WITHOUT GB		71421970	Incl.17,18				X	
8	1	END PLATE WITH GB		971423420	Incl.11,12,13,14,17,18					X
9	1	SCREW	M6							
10	1	SCREW	M6	971424710						
11	1	GAS BALLAST VALVE		971424450	Incl. 10,11a,b,c,d,e					
11a	1	O-RING	4 FKM	971424460		X				
11b	4	O-RING	10 FKM	71237320		X				
11c	1	SPRING		71417990						
11d	1	WASHER	M8							
11e	1	LOCKING RING	D18							
12	1	GAS BALLAST		71417050	Incl. 9,11b,12a					
12	1	GAS BALLAST		71418710	Incl. 9,11b,12a					
12a	1	MEMBRAN	D12 FKM	71417060		X				
13	1	RILSAN TUBE		71418040						X
14	1	CLAMPING RING	DN8	71418050						X
15	1	ROTOR WITH RINGS		71417400	Incl. 15a,b,c,d				X	X
15a	1	ROTOR RING	DN30	71416860			X			
15b	1	ROTOR RING	DN42				X			
15c	1	ROTOR RING	DN40				X			
15d	1	ROTOR RING	DN42				X			
16	1	VANE SET OF 3		71416750			X	X	X	
17	2	O-RING	9 FKM	71417260		X			X	X
18	1	O-RING	126 FKM	71417240		X			X	X
19	1	RUBBER MOUNT (SET OF 4)	DN30 H25	71212640	Incl.20					
20	4	HEXAGON FLANGE NUT	M8							
21	1	PUMP CYLINDER		71416600	Incl. 21a				X	X
21a	2	CENTERING PIN	DN8	71233890						
22	1	RADIAL SHAFT SEAL	40/62 FKM	71417010		X			X	X
23	1	MOTOR	1.5KW 50HZ 230/400V	71419820	Incl.23a,b,c,d,e,f,24,25					
23a	1	ELECTRICAL ROTOR		71416820						
23b	1	MOTOR RING		71416880						
23e	1	TERMINAL BOX		971422840						
23f	1	TERMINAL BOARD		971422860						
23	1	MOTOR	3HP 60HZ 230/460V	71419970	Incl. 23a,b,c,d,e,24,25					
23a	1	ELECTRICAL ROTOR		71416910						
23b	1	MOTOR RING		71416770						
23f	1	TERMINAL BOARD		971422900						
23	1	MOTOR	2.2KW 50/60HZ 200V	71422120	Incl.24a,b,c,d,25,26,27,28					
23a	1	ELECTRICAL ROTOR		71416910						
23b	1	MOTOR RING		71416770						
23e	1	TERMINAL BOX		971422840						
23f	1	TERMINAL BOARD		971422860						
23	1	MOTOR	1.8KW 50/60HZ 230/400V	71422130	Incl.23a,b,c,d,e,f,24,25					
23a	1	ELECTRICAL ROTOR		71416970						
23b	1	MOTOR RING		71416760						
23c	1	SCREW	M8							
23d	1	TIE ROD (SET OF 4)		71416800						
23e	1	TERMINAL BOX		971422840						
23f	1	TERMINAL BOARD		971422860						
24	1	FAN		71416840						
25	1	FAN COVER		71416830						
26	1	LIFTING LUG	M8	71402970						
27	1	O-RING	82 FKM	71421340		X				
28	1	SPRING		71212400						
29	1	INTAKE VALVE	FKM	71015460		X				
30	1	INTAKE FLANGE		71416640						
31	1	O-RING	50 FKM	71217660		X				
32	1	O-RING	42 FKM	71237130		X				
33	1	FILTER	DN45	71407290						
34	4	LOCKING SCREW	M8							
35	1	INTAKE FLANGE	G1 1/4	71416650						
35	1	INTAKE FLANGE	NPT 1 1/4	71417390	USA					
36	4	WASHER	8							

SV65 B

ERSATZTEILLISTE / SPARE PARTS LIST / LISTE DES PIÈCES DE RECHANGE SOGEVAC SV65 B

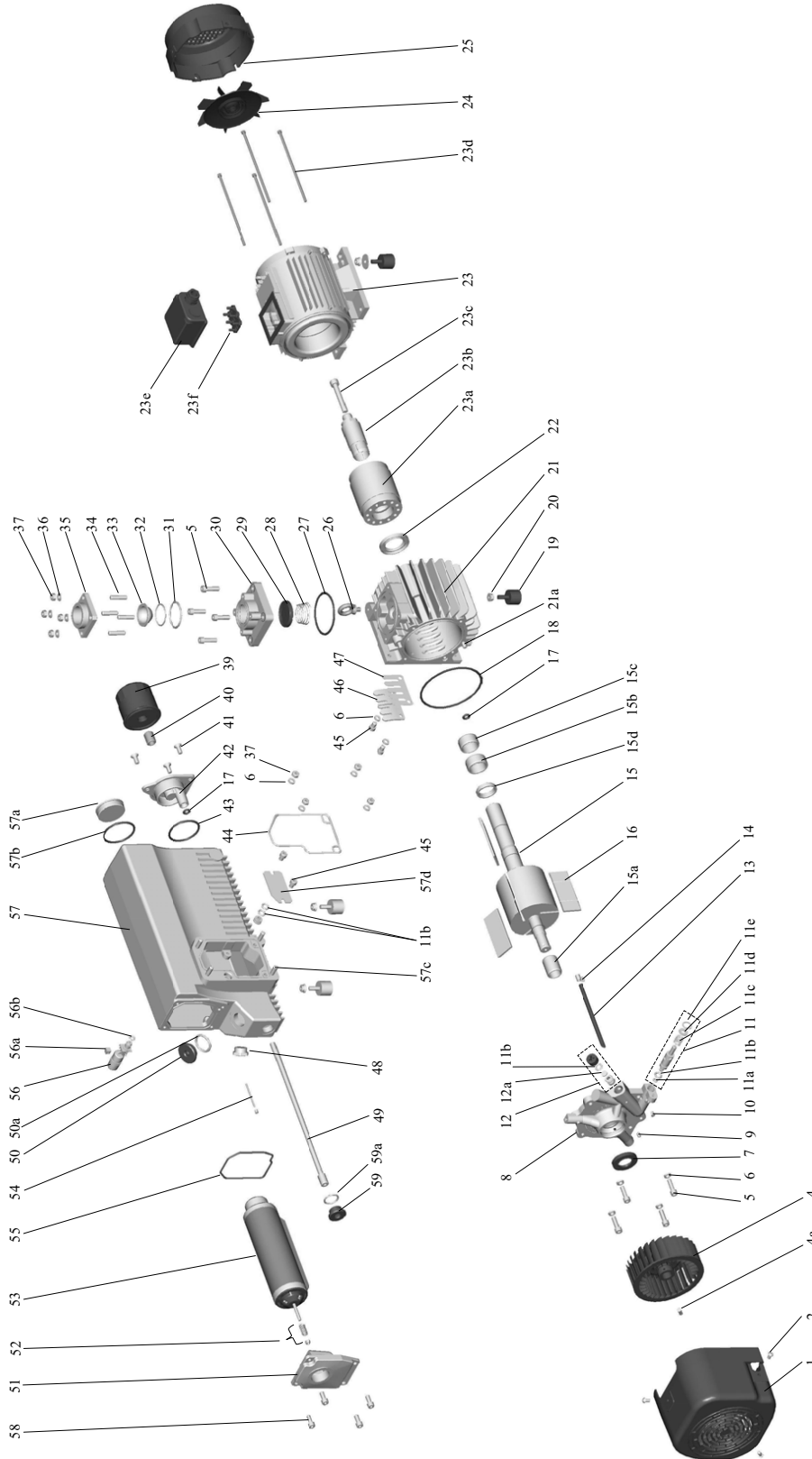

fig. 6

Spare parts

Pos.	Qty	SPECIFICATION	Dimensions (mm), Material	Ref, No,	Notes					
37	8	NUT	M8							
39	1	OIL FILTER		71420980			X			
40	1	NIPPLE	3/4 16 UNF 2A	71417150						
41	4	SCREW	M8							
42	1	OIL FILTER HOLDER		71418960	Incl. 40					
43	1	O-RING	63 FKM	71417330		X				
44	1	GASKET		ES971456801		X				
45	4	SCREW	M8				X	X	X	
46	1	VALVE STOP		71417100			X	X	X	
47	1	VALVE		71417090			X	X	X	
48	1	OIL LEVEL GLASS	G3/4	71219480			X			
49	1	OIL RECOVERY PIPE		71417130						
50	1	PLUG + O-RING	G 1	71073040	Incl. 50a					
50a	1	O-RING	33 FKM	71217410		X				X
51	1	EXHAUST FLANGE	G1 1/4	71420440						
51	1	EXHAUST FLANGE	NPT 1 1/4	71422000	USA					
52	1	SPRING UNIT		71420370			X			X
53	1	EXHAUST FILTER		71417300			X			X
54	1	CENTERING PIN	DN2.5	971427110						
55	1	GASKET	FKM	971454030		X				X
56	1	FLOAT COMPL.		71417210	Incl. 56a,b					
56a	1	OIL RETURN VALVE SEAL		71212500		X				
56b	1	O-RING	8 FKM	71217650		X				
57	1	OIL CASING WITH OIL FILTER		71419790	Incl. 45,57a,b,c,d					
57	1	OIL CASING WITHOUT OIL FILTER		71419830	Incl. 45,57a,b,c,d					
57a	2	PLUG + GASKET	G 2	71212650	Incl. 57b					
57b	1	O-RING	56 FKM	71217980		X				
57c	4	LOCKING SCREW M8X25	M8							
57d	1	GRID		71417170						
58	4	SCREW	M8							
59	1	PLUG + O-RING	G 3/4	71256380	Incl. 59a					
59a	1	O-RING	27 FKM	71217580		X				X
		SET OF SEALS	FKM	71420410			X			
		REPAIR KIT		71420420			X			
		VACUUM GENERATOR WITHOUT GB		71422080						
		VACUUM GENERATOR WITH GB		971423430						
		SERVICE KIT		971423440						

SV100 B

ERSATZTEILLISTE / SPARE PARTS LIST / LISTE DES PIECES DE RECHANGE SOGEVAC SV100 B

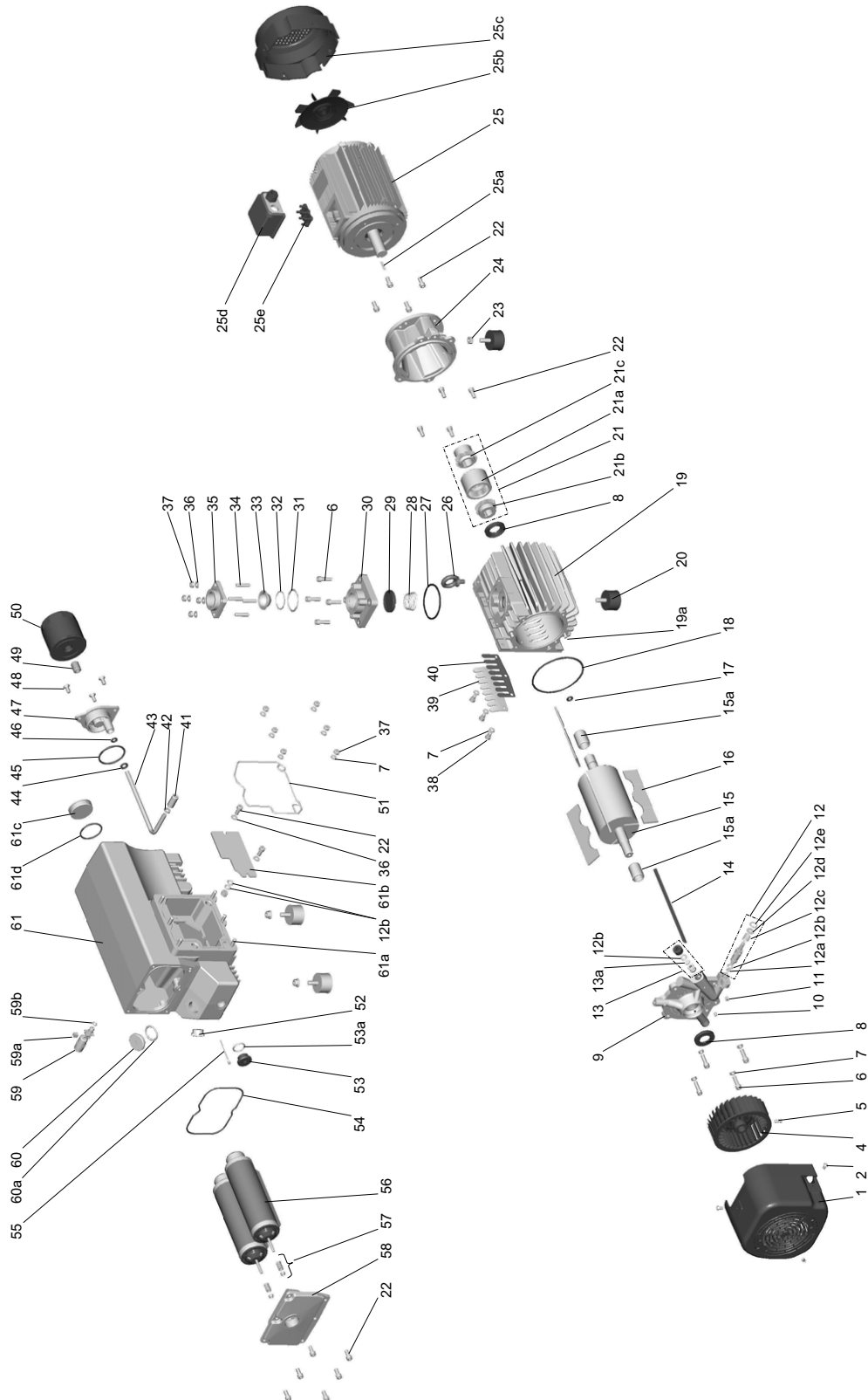

fig. 7

Spare parts

Pos.	Qty	SPECIFICATION	Dimensions (mm), Material	Ref. No,	Notes					
1	1	MODULE COVER		71417020	Incl. 2					
2	3	SCREW	M6							
4	1	SCREW	M6	71257660						
5	1	TURBINE		71417080						
6	8	SCREW	M8					X	X	
7	13	WASHER	W8					X	X	
8	2	RADIAL SHAFT SEAL		FKM 71417570		X		X	X	
9	1	END PLATE WITHOUT GB		971423900				X		
9	1	END PLATE WITH GB		971423930	Incl.12.13.14					X
10	1	SCREW	M6							
11	1	SCREW	M6	971424710						
12	1	GAS BALLAST VALVE		971431250	Incl. 11.12a,b,c,d,e					
12a	1	O-RING	4.5	FKM 971424460		X				
12b	4	O-RING	11	FKM 71237320		X				
12c	1	SPRING		71417990						
12d	1	WASHER	M8							
12e	1	LOCKING RING	D18							
13	1	GAS BALLAST		71417050	Incl. 10.12b.13a					
13	1	GAS BALLAST		71418710	Incl. 10.12b.13a					
13a	1	MEMBRAN	D12	FKM 71417060		X				
14	1	RILSAN TUBE	D5	71419130						X
15	1	ROTOR WITH RINGS		71418740	Incl. 15a			X	X	
15a	2	ROTOR RING	DN30	971427720			X			
16	1	VANE SET OF 3		71418750			X	X	X	X
17	1	O-RING	9	FKM 71417260		X		X	X	
18	1	O-RING	126	FKM 71417240		X		X	X	
19	1	PUMP CYLINDER		71418730	Incl. 19a			X	X	
19a	2	CENTERING PIN	DN8	71233890						
20	4	RUBBER MOUNT	DN50 H30	71024220						
21	1	COUPLING UNIT		71418770	Incl. 21a,b,c					
21a	1	TOOTHED RING	POLYAMIDE	71418780			X			
21b	1	PUMP COUPLING		71418980						
21c	1	MOTOR COUPLING		71418990						
21	1	USA COUPLING UNIT		71419740	USA Incl. 21a,b,c					
21a	1	TOOTHED RING	POLYAMIDE	71418780						
21b	1	PUMP COUPLING		71418980						
21c	1	USA MOTOR COUPLING		71419750	USA					
22	16	SCREW	M8							
22	4	USA SCREW	3/8"		USA					
23	4	HEXAGON FLANGE NUT	M8							
24	1	COUPLING HOUSING		71418790						
24	1	USA COUPLING HOUSING		971427760	USA					
25		SEE NEXT PAGE								
26	1	LIFTING LUG	M8	71039700						
27	1	O-RING	82	FKM 71421340		X				
28	1	SPRING		71212400						
29	1	INTAKE VALVE		FKM 71015460		X				
30	1	INTAKE FLANGE		71416640						
31	1	O-RING	50	FKM 71217660		X				
32	1	O-RING	42	FKM 71237130		X				
33	1	FILTER	DN45	71407290						
34	4	LOCKING SCREW	M8							
35	1	INTAKE FLANGE	G1 1/4	71416650						
35	1	INTAKE FLANGE	NPT 1 1/4	71417390	USA					
36	6	WASHER	Z8							
37	8	NUT	M8							
38	3	SCREW	M8					X	X	X
39	1	VALVE STOP		71418840				X	X	X
40	1	VALVE		71418830				X	X	X
41	1	PIPE		71418930						
42	1	GASKET	DN10	71418910		X				
43	1	OIL RECOVERY PIPE		71418880						
44	1	RING		971424570		X				
45	1	O-RING	9	FKM 71417260		X				
46	1	O-RING	63	FKM 71417330		X				
47	1	OIL FILTER HOLDER		71418960	Incl. 45					
48	4	SCREW	M8							
49	1	NIPPLE	3/4 16 UNF 2A	71417150						
50	1	OIL FILTER		71213150			X			
51	1	GASKET		ES971456811		X				
52	1	OIL LEVEL GLASS	G3/4	71219480			X			
53	1	PLUG + O-RING	G 3/4	71256380	Incl. 53a					
53a	1	O-RING	27	FKM 71217580		X				X
54	1	FLAT GASKET	160	FKM		X				X
55	1	CENTERING PIN	DN2.5	971427110						
56	2	EXHAUST FILTER		71417300			X			X
57	2	SPRING UNIT		71420370			X			X
58	1	EXHAUST FLANGE	G1 1/4	71418900						
58	1	EXHAUST FLANGE	NPT 1 1/4	71421780	USA					
59	1	FLOAT COMPL.		71417210	Incl. 59a,b					
59a	1	OIL RETURN VALVE SEAL		71212500		X				
59b	1	O-RING	8	FKM 71217650		X				
60	1	PLUG + O-RING	G 1	71073040	Incl. 60a					
60a	1	O-RING	33	FKM 71217410		X				X
61	1	OIL CASING WITH OIL FILTER		71420110	Incl. 61a,b,c,d					
61	1	OIL CASING WITHOUT OIL FILTER		971424390	Incl. 61a,b,c,d					
61a	6	LOCKING SCREW M8X25	M8							
61b	1	GRID		71418950						
61c	2	PLUG + GASKET	G 2	71212650	Incl. 61d					
61d	1	O-RING	56	FKM 71217980		X				
		SET OF SEALS		FKM 971427670				X		
		REPAIR KIT		971427680						
		VACUUM GENERATOR WITHOUT GB		971427740						
		VACUUM GENERATOR WITH GB		971427750						
		SERVICE KIT		971427690						

SV100 B

ERSATZTEILLISTE / SPARE PARTS LIST / LISTE DES PIECES DE RECHANGE SOGEVAC SV100 B

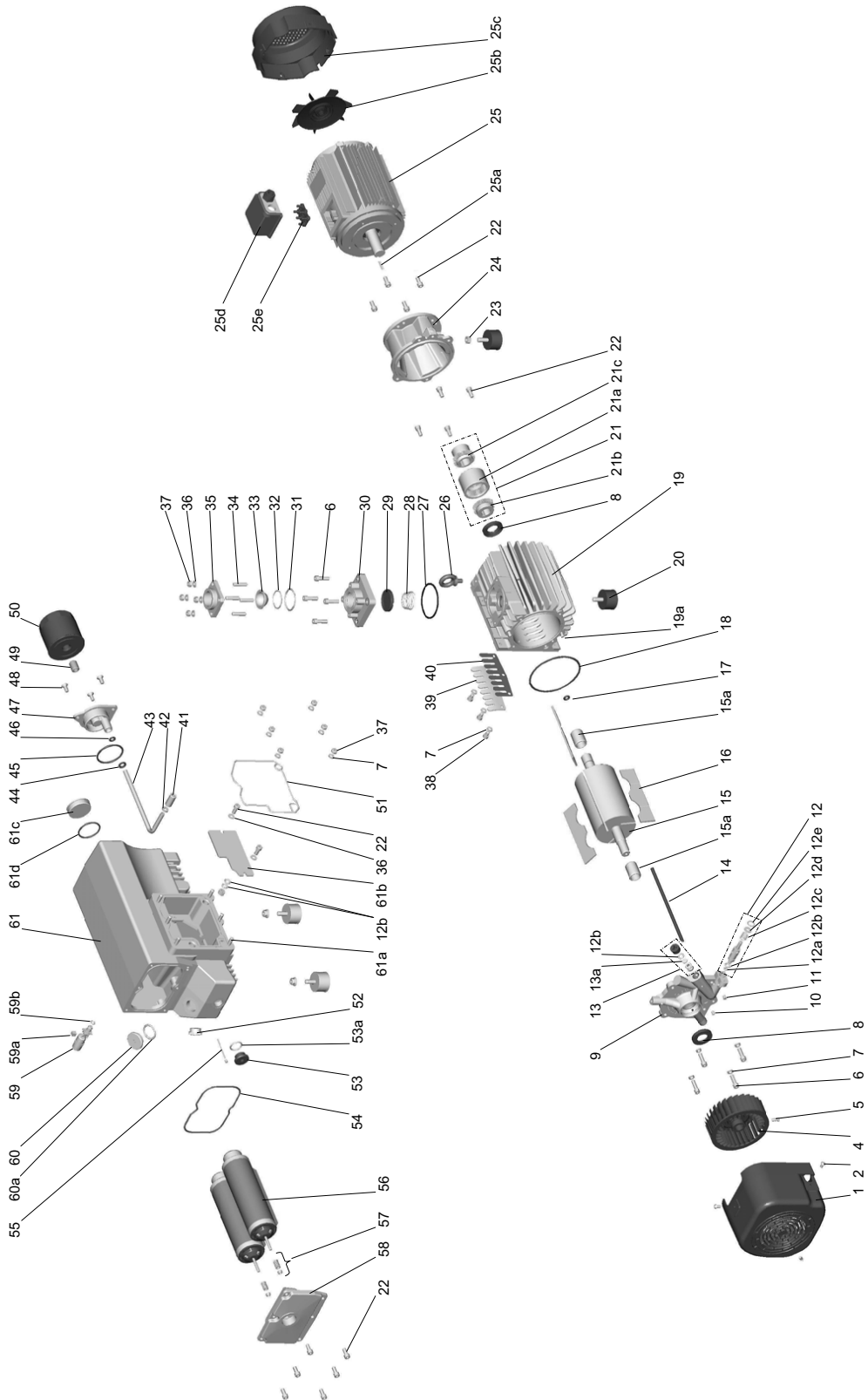

fig. 7

Spare parts

Pos.	Qty	SPECIFICATION	Dimensions (mm), Material	Ref, No,	Notes						
25	1	MOTOR	2.2KW 50/60HZ 230/400V	71418800	Incl.25a,b,c,d,e						
25a	1	KEY		*							
25b	1	FAN		*							
25c	1	FAN COVER		*							
25d	1	TERMINAL BOARD		*							
25e	1	TERMINAL BOARD		*							
25	1	MOTOR	5HP 60HZ 230/400V	971423660	Incl. 25a,b,c,d						
25a	1	KEY		*							
25b	1	FAN		*							
25c	1	FAN COVER		*							
25d	1	TERMINAL BOX		*							
25	1	MOTOR	3.7KW 50/60HZ 200V	971423670	Incl.25a,b,c,d,e						
25a	1	KEY		*							
25b	1	FAN		*							
25c	1	FAN COVER		*							
25d	1	TERMINAL BOX		*							
25e	1	TERMINAL BOARD		*							
25	1	MOTOR	2.2KW 50/60HZ 230-400V	971423680	Incl.25a,b,c,d,e						
25a	1	KEY		*							
25b	1	FAN		*							
25c	1	FAN COVER		*							
25d	1	TERMINAL BOX		*							
25e	1	TERMINAL BOARD		*							

* Für jeden auftrag bitte den Motorhersteller und die Seriennummer des motors und der Pumpe angeben.

* For every order, please indicate the brand and the serial number of motor and of the pump.

* Pour toute commande preciser la marque et le N° de serie du moteur et de la pompe.

EU Declaration of Conformity

(Translation of original Declaration of Conformity)

The manufacturer: Leybold GmbH
Bonner Strasse 498
D-50968 Köln
Germany

herewith declares that the products specified and listed below which we have placed on the market, comply with the applicable EU Council Directives. This declaration becomes invalid if modifications are made to the product without agreement of Leybold GmbH.

Product designation: SOGEVAC
Type designation: SV16, SV25, SV16D, SV25D, SV200, SV1200, SV16B, SV25B, SV40B, SV65B, SV100B, SV120B (I FC), SV300B, SV470B, SV500B, SV570B, SV630B, SV750B, SV28BI (FC), SV40BI (FC), SV65BI (FC), and their variants, excepted pumps delivered without motor

The products complies to the following European Council Directives:

Machinery Directive (2006/42/EC)

The safety objectives of the Low Voltage Directive 2014/35/EU were complied with in accordance with Appendix 1 No. 1.5.1 of Machinery Directive 2006/42/EC.

Electromagnetic Compatibility (2014/30/EU)

RoHS Directive (2011/65/EU) & (2015/863/EU)

The following harmonized standards have been applied:

EN 1012-2:1996+A1:2009	Compressors and vacuum pumps — Safety requirements — Part 2: Vacuum pumps
EN 60204-1:2006/A1:2009	Safety of machinery — Electrical equipment of machines — Part 1: General requirements requirements
EN 61000-6-2:2005/AC:2005	Electromagnetic compatibility (EMC) - Part 6-2: Generic standards - Immunity for industrial environments
EN 61000-6-4:2007/A1:2011	Electromagnetic compatibility (EMC) - Part 6-4: Generic standards - Emission standard for industrial environments

Documentation officer: Herbert Etges
T: +49(0)221 347 0
F: +49(0)221 347 1250
documentation@leybold.com

Cologne, November 14, 2016

Cologne, November 14, 2016

ppa. Martin Tollner
Head of Product Lines

ppa. Dr. Monika Mattern-Klosson
Head of Quality & Business Process Management

Declaration of Contamination of Compressors, Vacuum Pumps and Components

The repair and / or servicing of compressors, vacuum pumps and components will be carried out only if a correctly completed declaration has been submitted. Non-completion will result in delay. The manufacturer can refuse to accept any equipment without a declaration.

A separate declaration has to be completed for each single component.

This declaration may be completed and signed only by authorized and qualified staff.

Customer/Dep./Institute : _____ Address : _____ _____ Person to contact: _____ Phone : _____ Fax: _____ End user: _____	Reason for return: <input checked="" type="checkbox"/> applicable please mark Repair: <input type="checkbox"/> chargeable <input type="checkbox"/> warranty Exchange: <input type="checkbox"/> chargeable <input type="checkbox"/> warranty <input type="checkbox"/> Exchange already arranged / received Return only: <input type="checkbox"/> rent <input type="checkbox"/> loan <input type="checkbox"/> for credit Calibration: <input type="checkbox"/> DKD <input type="checkbox"/> Factory-calibr. <input type="checkbox"/> Quality test certificate DIN 55350-18-4.2.1																																																																
A. Description of the Leybold product: _____ Failure description: _____ Material description : _____ Catalog number: _____ Additional parts: _____ Serial number: _____ Application-Tool: _____ Type of oil (ForeVacuum-Pumps) : _____ Application- Process: _____																																																																	
B. Condition of the equipment <table style="width:100%; border-collapse: collapse;"> <thead> <tr> <th style="width:60%;"></th> <th style="width:10%; text-align: center;">No¹⁾</th> <th style="width:10%; text-align: center;">Yes</th> <th style="width:10%; text-align: center;">No</th> <th style="width:10%;"></th> <th style="width:10%;"></th> <th style="width:10%; text-align: center;">No¹⁾</th> <th style="width:10%; text-align: center;">Yes</th> </tr> </thead> <tbody> <tr> <td>1. Has the equipment been used</td> <td style="text-align: center;"><input type="checkbox"/></td> <td style="text-align: center;"><input type="checkbox"/></td> <td style="text-align: center;"><input type="checkbox"/></td> <td style="text-align: center;">→</td> <td>toxic</td> <td style="text-align: center;"><input type="checkbox"/></td> <td style="text-align: center;"><input type="checkbox"/></td> </tr> <tr> <td>2. Drained (Product/service fluid)</td> <td style="text-align: center;">↓</td> <td style="text-align: center;"><input type="checkbox"/></td> <td style="text-align: center;"><input type="checkbox"/></td> <td></td> <td>corrosive</td> <td style="text-align: center;"><input type="checkbox"/></td> <td style="text-align: center;"><input type="checkbox"/></td> </tr> <tr> <td>3. All openings sealed airtight</td> <td style="text-align: center;">↓</td> <td style="text-align: center;"><input type="checkbox"/></td> <td style="text-align: center;"><input type="checkbox"/></td> <td></td> <td>flammable</td> <td style="text-align: center;"><input type="checkbox"/></td> <td style="text-align: center;"><input type="checkbox"/></td> </tr> <tr> <td>4. Purged</td> <td style="text-align: center;">↓</td> <td style="text-align: center;"><input type="checkbox"/></td> <td style="text-align: center;"><input type="checkbox"/></td> <td></td> <td>explosive ²⁾</td> <td style="text-align: center;"><input type="checkbox"/></td> <td style="text-align: center;"><input type="checkbox"/></td> </tr> <tr> <td colspan="4">If yes, which cleaning agent _____</td> <td></td> <td>radioactive ²⁾</td> <td style="text-align: center;"><input type="checkbox"/></td> <td style="text-align: center;"><input type="checkbox"/></td> </tr> <tr> <td colspan="4">and which method of cleaning _____</td> <td></td> <td>microbiological ²⁾</td> <td style="text-align: center;"><input type="checkbox"/></td> <td style="text-align: center;"><input type="checkbox"/></td> </tr> <tr> <td colspan="4">1) If answered with "No", go to D. ←</td> <td></td> <td>other harmful substances</td> <td style="text-align: center;"><input type="checkbox"/></td> <td style="text-align: center;"><input type="checkbox"/></td> </tr> </tbody> </table>			No ¹⁾	Yes	No			No ¹⁾	Yes	1. Has the equipment been used	<input type="checkbox"/>	<input type="checkbox"/>	<input type="checkbox"/>	→	toxic	<input type="checkbox"/>	<input type="checkbox"/>	2. Drained (Product/service fluid)	↓	<input type="checkbox"/>	<input type="checkbox"/>		corrosive	<input type="checkbox"/>	<input type="checkbox"/>	3. All openings sealed airtight	↓	<input type="checkbox"/>	<input type="checkbox"/>		flammable	<input type="checkbox"/>	<input type="checkbox"/>	4. Purged	↓	<input type="checkbox"/>	<input type="checkbox"/>		explosive ²⁾	<input type="checkbox"/>	<input type="checkbox"/>	If yes, which cleaning agent _____					radioactive ²⁾	<input type="checkbox"/>	<input type="checkbox"/>	and which method of cleaning _____					microbiological ²⁾	<input type="checkbox"/>	<input type="checkbox"/>	1) If answered with "No", go to D. ←					other harmful substances	<input type="checkbox"/>	<input type="checkbox"/>
	No ¹⁾	Yes	No			No ¹⁾	Yes																																																										
1. Has the equipment been used	<input type="checkbox"/>	<input type="checkbox"/>	<input type="checkbox"/>	→	toxic	<input type="checkbox"/>	<input type="checkbox"/>																																																										
2. Drained (Product/service fluid)	↓	<input type="checkbox"/>	<input type="checkbox"/>		corrosive	<input type="checkbox"/>	<input type="checkbox"/>																																																										
3. All openings sealed airtight	↓	<input type="checkbox"/>	<input type="checkbox"/>		flammable	<input type="checkbox"/>	<input type="checkbox"/>																																																										
4. Purged	↓	<input type="checkbox"/>	<input type="checkbox"/>		explosive ²⁾	<input type="checkbox"/>	<input type="checkbox"/>																																																										
If yes, which cleaning agent _____					radioactive ²⁾	<input type="checkbox"/>	<input type="checkbox"/>																																																										
and which method of cleaning _____					microbiological ²⁾	<input type="checkbox"/>	<input type="checkbox"/>																																																										
1) If answered with "No", go to D. ←					other harmful substances	<input type="checkbox"/>	<input type="checkbox"/>																																																										
C. Description of processed substances (Please fill in absolutely) 1. What substances have come into contact with the equipment ? Trade name and / or chemical term of service fluids and substances processed, properties of the substances According to safety data sheet (e.g. toxic, inflammable, corrosive, radioactive) <table border="1" style="width:100%; border-collapse: collapse;"> <thead> <tr> <th style="width:5%;"></th> <th style="width:25%;">Tradename:</th> <th style="width:70%;">Chemical name:</th> </tr> </thead> <tbody> <tr><td style="text-align: center;">X</td><td></td><td></td></tr> <tr><td style="text-align: center;">a)</td><td></td><td></td></tr> <tr><td style="text-align: center;">b)</td><td></td><td></td></tr> <tr><td style="text-align: center;">c)</td><td></td><td></td></tr> <tr><td style="text-align: center;">d)</td><td></td><td></td></tr> </tbody> </table>			Tradename:	Chemical name:	X			a)			b)			c)			d)																																																
	Tradename:	Chemical name:																																																															
X																																																																	
a)																																																																	
b)																																																																	
c)																																																																	
d)																																																																	
2. Are these substances harmful ? <input type="checkbox"/> No <input type="checkbox"/> Yes ← 3. Dangerous decomposition products when heated ? <input type="checkbox"/> No <input type="checkbox"/> Yes If yes, which ? _____																																																																	
²⁾ Components contaminated by microbiological, explosive or radioactive products/substances will not be accepted without written evidence of decontamination.																																																																	

D. Legally binding declaration

I / we hereby declare that the information supplied on this form is accurate and sufficient to judge any contamination level.

Name of authorized person (block letters) : _____



_____ Date

_____ signature of authorized person

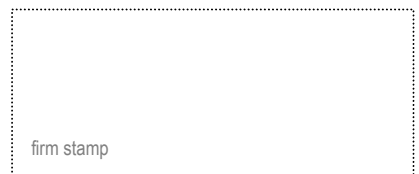

Sales and Service

Germany

Leybold GmbH

Sales, Service, Support Center (3SC)
Bonner Strasse 498
D-50968 Cologne
T: +49-(0)221-347 1234
F: +49-(0)221-347 31234
sales@leybold.com
www.leybold.com

Leybold GmbH

Sales Area North

Branch Office Berlin
Industriestrasse 10b
D-12099 Berlin
T: +49-(0)30-435 609 0
F: +49-(0)30-435 609 10
sales.bn@leybold.com

Leybold GmbH

Sales Office South

Branch Office Munich
Karl-Hammerschmidt-Strasse 34
D-85609 Aschheim-Dornach
T: +49-(0)89-357 33 9-10
F: +49-(0)89-357 33 9-33
sales.mn@leybold.com
service.mn@leybold.com

Leybold Dresden GmbH

Service Competence Center

Zur Wetterwarte 50, Haus 304
D-01109 Dresden
Service:
T: +49-(0)351-88 55 00
F: +49-(0)351-88 55 041
info.dr@leybold.com

Europe

Belgium

Leybold Nederland B.V.

Belgisch bijkantoor

Leuvensesteenweg 542-9A
B-1930 Zaventem
Sales:
T: +32-2-711 00 83
F: +32-2-720 83 38
sales.zv@leybold.com
Service:
T: +32-2-711 00 82
F: +32-2-720 83 38
service.zv@leybold.com

France

Leybold France S.A.S.

Parc du Technopolis, Bâtiment Beta
3, Avenue du Canada
F-91940 Les Ulis cedex
Sales and Service:
T: +33-1-69 82 48 00
F: +33-1-69 07 57 38
info.ctb@leybold.com
sales.ctb@leybold.com

Leybold France S.A.S.

Valence Factory
640, Rue A. Bergès
B.P. 107
F-26501 Bourg-lès-Valence Cedex
T: +33-4-75 82 33 00
F: +33-4-75 82 92 69
marketing.vc@leybold.com

Great Britain

Leybold UK LTD.

Unit 9
Silverglade Business Park
Leatherhead Road
Chessington
Surrey (London)
KT9 2QL
Sales:
T: +44-13-7273 7300
F: +44-13-7273 7301
sales.ln@leybold.com
Service:
T: +44-13-7273 7320
F: +44-13-7273 7303
service.ln@leybold.com

Italy

Leybold Italia S.r.l.

Via Trasimeno 8
I-20128 Mailand
Sales:
T: +39-02-27 22 31
F: +39-02-27 20 96 41
sales.mi@leybold.com
Service:
T: +39-02-27 22 31
F: +39-02-27 22 32 17
service.mi@leybold.com

Netherlands

Leybold Nederland B.V.

Floridadreef 102
NL-3565 AM Utrecht
Sales and Service:
T: +31-(30) 242 63 30
F: +31-(30) 242 63 31
sales.ut@leybold.com
service.ut@leybold.com

Switzerland

Leybold Schweiz AG, Pfäffikon

Churerstrasse 120
CH-8808 Pfäffikon
Warehouse and shipping address:
Riedthofstrasse 214
CH-8105 Regensdorf
Sales:
T: +41-44-308 40 50
F: +41-44-302 43 73
sales.zh@leybold.com
Service:
T: +41-44-308 40 62
F: +41-44-308 40 60
service.zh@leybold.com

Spain

Leybold Spain, S.A.

C/. Huelva, 7
E-08940 Cornellà de Llobregat
(Barcelona)
Sales:
T: +34-93-666 43 11
F: +34-93-666 43 70
sales.ba@leybold.com
Service:
T: +34-93-666 46 11
F: +34-93-685 43 70
service.ba@leybold.com

America

USA

Leybold USA Inc.

5700 Mellon Road
USA-Export, PA 15632
T: +1-724-327-5700
F: +1-724-325-3577
info.ex@leybold.com
Sales:
T: +1-724-327-5700
F: +1-724-333-1217
Service:
T: +1-724-327-5700
F: +1-724-325-3577

Brazil

Leybold do Brasil

Rod. Vice-Prefeito Hermenegildo Tonolli,
nº. 4413 - 6B
Distrito Industrial
Jundiaí - SP
CEP 13.213-086
Sales and Service:
T: +55 11 3395 3180
F: +55 11 99467 5934
sales.ju@leybold.com
service.ju@leybold.com

Asia

P. R. China

Leybold (Tianjin)

International Trade Co. Ltd.
Beichen Economic
Development Area (BEDA),
No. 8 Western Shuangchen Road
Tianjin 300400
China
Sales and Service:
T: +86-22-2697 0808
F: +86-22-2697 4061
F: +86-22-2697 2017
sales.tj@leybold.com
service.tj@leybold.com

India

Leybold India Pvt Ltd.

No. 82(P), 4th Phase
K.I.A.D.B. Plot
Bommasandra Industrial Area
Bangalore - 560 099
Indien
Sales and Service:
T: +91-80-2783 9925
F: +91-80-2783 9926
sales.bg@leybold.com
service.bg@leybold.com

Japan

Leybold Japan Co., Ltd.

Headquarters
Shin-Yokohama A.K.Bldg., 4th floor
3-23-3, Shin-Yokohama
Kohoku-ku, Yokohama-shi
Kanawaga 222-0033
Japan
Sales:
T: +81-45-471-3330
F: +81-45-471-3323
sales.yh@leybold.com

Leybold Japan Co., Ltd.

Tsukuba Technical Service Center
1959, Kami-yokoba
Tsukuba-shi, Ibaraki-shi 305-0854
Japan
Service:
T: +81-29 839 5480
F: +81-29 839 5485
service.iik@leybold.com

Malaysia

Leybold Malaysia

Leybold Singapore Pte Ltd.

No. 1 Jalan Hi-Tech 2/6
Kulim Hi-Tech Park
Kulim, Kedah Darul
Aman 09000
Malaysia
Sales and Service:
T: +604 4020 222
F: +604 4020 221
sales.ku@leybold.com
service.ku@leybold.com

South Korea

Leybold Korea Ltd.

3F. Jelzone 2 Tower
Jeongja-dong 159-4
Bundang-gu Sungnam-si
Gyeonggi-do
Bundang 463-384, Korea
Sales:
T: +82-31 785 1367
F: +82-31 785 1359
sales.bd@leybold.com
Service:
623-7, Ulsung-Dong
Cheonan-Si
Chungcheongnam-Do
Korea 330-290
T: +82-41 589 3035
F: +82-41 588 0166
service.cn@leybold.com

Singapore

Leybold Singapore Pte Ltd.

8 Commonwealth Lane #01-01
Singapore 149555
Singapore
Sales and Service:
T: +65-6303 7030
F: +65-6773 0039
sales.sg@leybold.com
service.sg@leybold.com

Taiwan

Leybold Taiwan Ltd.

No 416-1, Sec. 3
Chunghsin Rd., Chutung
Hsinchu County 310
Taiwan, R.O.C.
Sales and Service:
T: +886-3-500 1688
F: +886-3-583 3999
sales.hc@leybold.com
service.hc@leybold.com

Headquarter

Leybold GmbH

Bonner Strasse 498
D-50968 Cologne
T: +49-(0)221-347-0
F: +49-(0)221-347-1250
info@leybold.com



www.leybold.com