

TRIVAC D 8B

6.9 CFM

2 stage rotary vane vacuum pump

oerlikon
leybold vacuum



\$2,298.00
2009 Pricing

Technical Data

50hz 60hz

Nominal pumping speed ¹⁾	m ³ x h ⁻¹ (cfm)	9.7 (5.7)	11.6 (6.9)
Pumping speed ¹⁾	m ³ x h ⁻¹ (cfm)	8.5 (5)	10.2(6)
Ultimate partial pressure without gas ballast ¹⁾	mbar (Torr)	10 ⁻⁴ (0.75 x 10 ⁻⁴)	
Ultimate total pressure without gas ballast ¹⁾	mbar (Torr)	< 2 x 10 ⁻³ (< 1.5 x 10 ⁻³)	
Ultimate total pressure with gas ballast ¹⁾	mbar (Torr)	< 5 x 10 ⁻³ (< 3.8 x 10 ⁻³)	
Water vapor tolerance ¹⁾	mbar (Torr)	25 (18.8)	
Water vapor capacity	gm/h	157	
Oil filling, min./max.	l (qt)	0.3 / 0.9 (.3 / .95)	
Noise level * to DIN 45 635, without/with gas ballast	dB(A)	50 / 52	
Admissible ambient temperature	°C (°F)	12 - 40 (54 - 104)	
Motor rating *	W (HP)	370 (.50)	
Nominal speed	rpm	1500	1800
Type of protection	IP	54	
Weight*	kg (lbs)	21.2 (46.7)	
Connections, Intake and Exhaust	DN	16 KF	

Pumping Curves

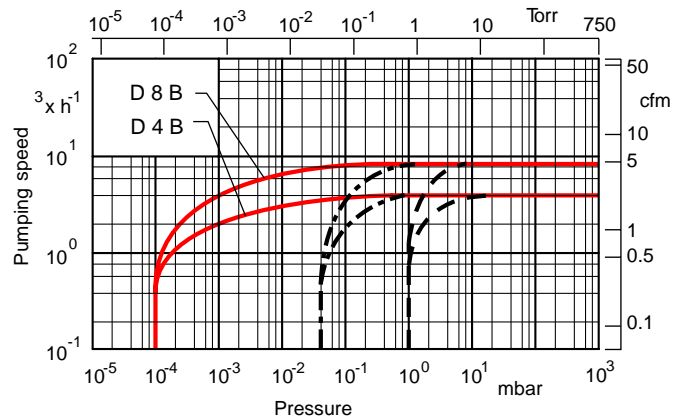

— Ultimate partial pressure without gas ballast
 - - - Ultimate total pressure without gas ballast
 - · - · Ultimate total pressure with gas ballast

Pumping speed characteristics at 50 Hz
 (60 Hz curves at the end of the section)

Leybold Trivac D Series Small Pumps



Model	CFM	Price
D4B	3.4	\$2,078.00
D8B	6.9	\$2,298.00
D16B	13.4	\$2,995.00
D25B	20.9	\$3,995.00

oerlikon
leybold vacuum



Motor Information

D 4 B

D 8 B

Cat. No.	l (mm)	W (kg)	Cat. No.	l (mm)	W (kg)	Motor connection voltage, frequency	Motor power	Rated current	Speed	Motor noise level	Order No. motor
112 45	430	18,7	112 55	455	21.2	1~, 230 V, 50 Hz	370 W	2,9 A	1400	47 dB(A)	360 66 008
113 03	430	18,7	113 13	455	21,2	1~, 115 V, 60 Hz	370 W	5,6 A	1700	51 dB(A)	200 10 403
113 04	470	19,7	113 14	495	25,2	1~, 100 V, 50 Hz	370 W	8,7 A	1400	53 dB(A)	200 10 404
113 08 ¹⁾	470	19,7	113 18 ¹⁾	495	25,2	1~, 110 V, 60 Hz	370 W	6,1 A	1700	56 dB(A)	200 10 404
112 46	438	16,4	112 56	463	18,6	3~, 230/400 V, 50 Hz 250/440 V, 60 Hz	370 W	1,95/1,12 A 1,73/1,0 A	1970 1680	46 dB(A) 50 dB(A)	380 66 006
113 06	430	18	113 16	455	18,6	3~, 230/400 V, 50 Hz	370 W	1,92/1,11 A	1395	45 dB(A)	200 10 406
113 07	223	10,6	113 17	248	12,8	ohne Motor	-	-	-	48 dB(A)	-
113 09			113 21			1~, 230 V, 50/60 Hz	370 W	4,9/3,3 A	1400 1700	53/56 dB(A)	200 39 867

¹⁾ Motor with UL cable NEMA 5-158 and 2.5 m long cable

Dimensions

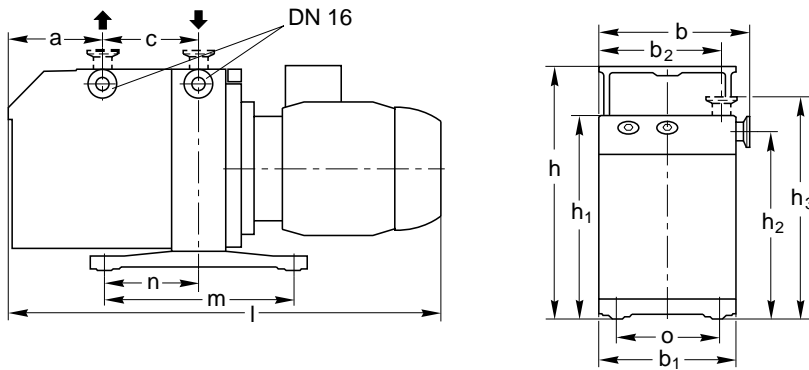

oerlikon
leybold vacuum



Type	DN	a	b	b ₁	b ₂	c	h	h ₁	h ₂	h ₃	l*	m	n	o
D 4 B	16 KF	mm 75 in. 2.95	162 6.38	147 5.79	132 5.20	100 3.94	265 10.4	215 8.46	200 7.84	230 9.06	430 16.9	198 7.80	99 3.90	108 4.25
D 4 B (Part No. 113 04)		mm 75 in. 2.95									470 18.5			
D 4 B (Part No. 113 14)		mm 75 in. 2.95									495 19.5			
D 8 B		mm 100 in. 3.94									455 17.9			
D 8 B (Part No. 113 18 (Arctic))		mm 100 in. 3.94									495 19.5			

* Depending on the motor

USA pumps max. length
D 4 B 485 mm (19.1")
D 8 B 555 mm (21.9")

Accessories (many other KF16 fittings in stock)



KF16 Half Nipple
P/N P101217
\$11.80



KF16 Toggle Clamp
P/N P101638
\$13.25

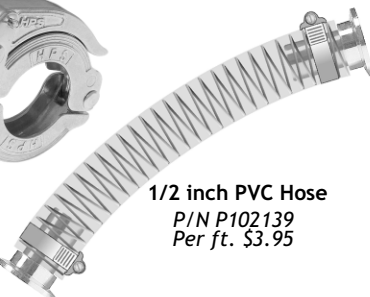

1/2 inch PVC Hose
P/N P102139
Per ft. \$3.95



P/N P101879
\$99.00



P/N P102026
\$143.00



HE200 Oil

P/N P101503
1 Quart \$31.00

P/N P101501
1 Gallon \$101.00

oerlikon
leybold vacuum

