

**ærlikon**  
leybold vacuum

# **PENNINGVAC**

## **PTR 90**

**Operating Manual GA09313\_0202**

Part Numbers

230 070  
230 071  
230 072

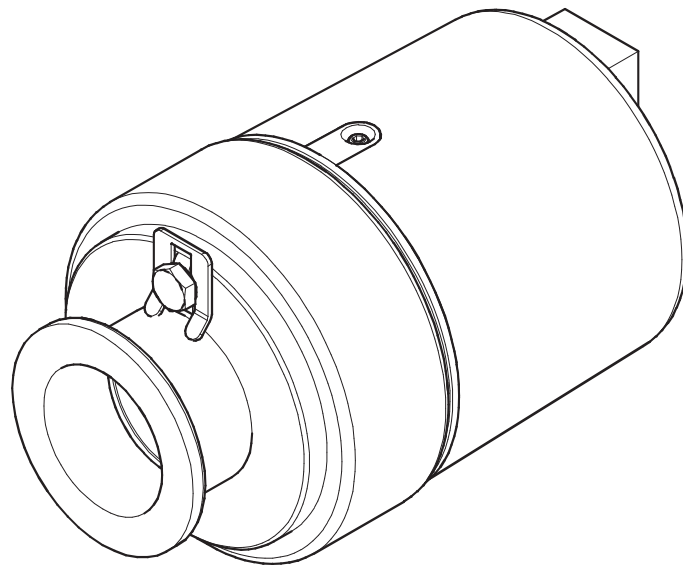

# General Information

## Product Identification

In all communications with Oerlikon Leybold Vacuum, please specify the information given on the product nameplate. For convenient reference copy that information into the space provided below:

Oerlikon Leybold Vacuum, D-50968 Köln	
Type: .....	
No: .....	☒ CE
F-No: .....	
..... V .....	..... W .....

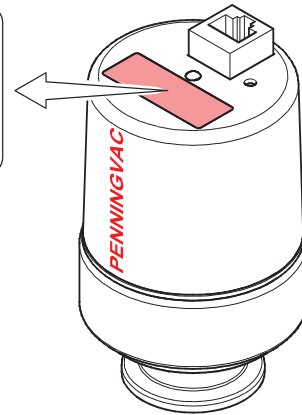

## Validity

This document applies to products with catalog numbers:

230 070	(DN 25 ISO-KF)
230 071	(DN 40 ISO-KF)
230 072	(DN 40 CF-F)

The catalog number (No) can be taken from the product nameplate.

If not indicated otherwise in the legends, the illustrations in this document correspond to transmitters with the vacuum connection DN 25 ISO-KF. They apply to transmitters with other vacuum connections by analogy.

We reserve the right to make technical changes without prior notice.

All dimensions in mm.

## Intended Use

The PENNINGVAC Transmitter PTR 90 has been designed for vacuum measurement in the pressure range of  $5 \times 10^{-9}$  ... 1000 mbar.

The transmitter must not be used for measuring flammable or combustible gases which react in air.

It can be operated in connection with an Oerlikon Leybold Vacuum gauge controller CENTER ONE, CENTER TWO or CENTER THREE, or with another controller.

## Functional Principle

Over the whole measuring range, the measuring signal is output as a logarithm of the pressure.

The transmitter consists of two separate measurement systems (Pirani and cold cathode system) the signals of which are combined in such a way that one measurement signal is output. The Pirani measurement circuit is always on.

# Contents

## Contents

Product Identification	2
Validity	2
Intended Use	2
Functional Principle	2
<b>1 Safety</b>	<b>4</b>
1.1 Symbols Used	4
1.2 Personnel Qualifications	4
1.3 General Safety Instructions	4
1.4 Liability and Warranty	5
<b>2 Technical Data</b>	<b>6</b>
<b>3 Installation</b>	<b>9</b>
3.1 Vacuum Connection	9
3.1.1 Removing the Magnet Unit (Only for Transmitters With CF Flange)	11
3.2 Electrical Connection	12
3.2.1 Use With an Oerlikon Leybold Vacuum Controller	12
3.2.2 Use With Another Control Device	12
<b>4 Operation</b>	<b>13</b>
4.1 Principle, Measuring Behavior	13
<b>5 Deinstallation</b>	<b>15</b>
<b>6 Maintenance</b>	<b>16</b>
6.1 Adjusting the Transmitter	16
6.2 Cleaning the Transmitter, Replacing Parts	18
6.2.1 Disassembling the Transmitter	18
6.2.2 Cleaning the Transmitter	19
6.2.3 Reassembling the Transmitter	20
6.3 Troubleshooting	22
<b>7 Accessories</b>	<b>23</b>
<b>8 Spare Parts</b>	<b>23</b>
<b>9 Returning the Product</b>	<b>24</b>
<b>10 Disposal</b>	<b>25</b>
<b>Appendix</b>	<b>26</b>
A: Relationship Between Measuring Signal and Pressure	26
B: Gas Type Dependence	28
<b>Declaration of Contamination</b>	<b>30</b>

For cross-references within this document, the symbol (→  XY) is used.

# Safety

## 1 Safety

### 1.1 Symbols Used

 <b>DANGER</b>
Information on preventing any kind of physical injury.

 <b>WARNING</b>
Information on preventing extensive equipment and environmental damage.



 <b>Caution</b>
Information on correct handling or use. Disregard can lead to malfunctions or minor equipment damage.

### 1.2 Personnel Qualifications

 <b>Skilled personnel</b>
All work described in this document may only be carried out by persons who have suitable technical training and the necessary experience or who have been instructed by the end-user of the product.

### 1.3 General Safety Instructions

- Adhere to the applicable regulations and take the necessary precautions for the process media used.  
Consider possible reactions between the materials (→ 7) and the process media.  
Consider possible reactions (e.g. explosion) of the process media due to the heat generated by the product.
- Adhere to the applicable regulations and take the necessary precautions for all work you are going to do and consider the safety instructions in this document.
- Before beginning to work, find out whether any vacuum components are contaminated. Adhere to the relevant regulations and take the necessary precautions when handling contaminated parts.

 <b>DANGER</b>
 <b>DANGER: magnetic fields</b> Strong magnetic fields can disturb electronic devices like heart pacemakers or impair their function.
 Maintain a safety distance of $\geq 10$ cm between the magnet and the heart pacemaker or prevent the influence of strong magnetic fields by antimagnetic shielding.

Communicate the safety instructions to all other users.

## 1.4 Liability and Warranty

Oerlikon Leybold Vacuum assumes no liability and the warranty becomes null and void if the end-user or third parties

- disregard the information in this document
- use the product in a non-conforming manner
- make any kind of interventions (modifications, alterations etc.) on the product
- use the product with accessories not listed in the product documentation.

The end-user assumes the responsibility in conjunction with the process media used.

Transmitter failures due to contamination, as well as expendable parts (filament), are not covered by the warranty.

# Technical Data

## 2 Technical Data

Measurement range (Air, N <sub>2</sub> )	5×10 <sup>-9</sup> ... 1000 mbar
Accuracy (N <sub>2</sub> )	≈±30% in the range 1×10 <sup>-8</sup> ... 100 mbar
Repeatability	≈±5% in the range 1×10 <sup>-8</sup> ... 100 mbar
Gas type dependence	→  28

Output signal (measuring signal)	
Voltage range	0 ... +10.5 V
Measurement range	1.82 ... 8.6 V
Voltage vs. pressure	logarithmic, 0.6 V / decade (→  26)
Error signal	<0.5 V no supply >9.5 V Pirani sensor defective (filament rupture)

Output impedance	2×10 Ω
Minimum loaded impedance	10 kΩ, short-circuit proof
Response time (pressure dependent)	
p > 10 <sup>-6</sup> mbar	<10 ms
p = 10 <sup>-8</sup> mbar	≈1000 ms

Identification transmitter	85 kΩ, referenced to supply common
----------------------------	------------------------------------

Status	pin 6
p > 10 <sup>-2</sup> mbar Pirani-only mode	Low = 0 V
p < 10 <sup>-2</sup> mbar Cold cathode not ignited Pirani-only mode	Low = 0 V
p < 10 <sup>-2</sup> mbar Cold cathode ignited Combined Pirani / cold cathode mode	High = 15 ... 30 VDC

LED	High voltage on (LED on)
-----	--------------------------

### Supply

**DANGER**

The transmitter may only be connected to power supplies, instruments or control devices that conform to the requirements of a grounded extra-low voltage (SELV-E according to EN 61010). The connection to the transmitter has to be fused <sup>1)</sup>.

Voltage at the transmitter	15 ... 30 VDC (ripple ≤ 1 V <sub>pp</sub> )
Power consumption	≤2 W
Fuse <sup>1)</sup>	≤1 AT
The minimum voltage of the power supply unit must be increased proportionally to the length of the sensor cable.	
Voltage at the supply unit with maximum cable length	16 ... 30 VDC (ripple ≤ 1 V <sub>pp</sub> )

<sup>1)</sup> Oerlikon Leybold Vacuum controllers fulfill these requirements.

# Technical Data

Adjustment	
Potentiometer <HV>	adjustment under $10^{-4}$ mbar
Potentiometer <ATM>	adjustment at atmospheric pressure
Electrical connection	FCC68 socket, 8 poles
Sensor cable	8 poles, shielded
Line length	$\leq 50$ m (8x0.14 mm <sup>2</sup> )
Operating voltage	$\leq 3.3$ kV
Operating current	$\leq 500$ $\mu$ A
Grounding concept	→ ("Electrical Connection")
Vacuum connection – measuring common	connected via 10 k $\Omega$ (max. voltage differential with respect to safety $\pm 50$ V accuracy $\pm 10$ V)
Supply common – signal common	conducted separately
Materials exposed to vacuum	
Vacuum connection	stainless steel
Measurement chamber	stainless steel
Feedthrough isolation	ceramic
Internal seals	FPM
Anode	Mo
Ignition aid	stainless steel
Pirani measurement tube	Ni, Au
Pirani filament	W
Mounting orientation	any
Internal volume	$\approx 20$ cm <sup>3</sup>
Pressure	$\leq 10$ bar (absolute), limited to inert gases
Temperatures	
Operation	+5 ... +55 °C
Bakeout	+150 °C (without electronics and magnetic shielding)
Pirani filament	+120 °C
Storage	-40 °C ... +65 °C
Relative humidity	$\leq 80\%$ at temperatures $\leq +31$ °C decreasing to 50% at +40°C
Use	indoors only altitude up to 2000 m
Type of protection	IP40

# Technical Data

Dimensions [mm]

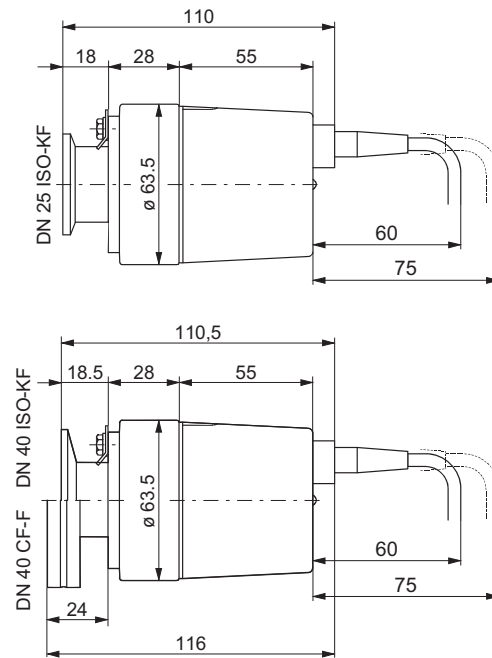

Weight

230 070	$\approx 700$ g
230 071	$\approx 720$ g
230 072	$\approx 980$ g

## 3 Installation

### 3.1 Vacuum Connection

**DANGER**

**DANGER:** overpressure in the vacuum system >1 bar

Injury caused by released parts and harm caused by escaping process gases can result if clamps are opened while the vacuum system is pressurized.

Do not open any clamps while the vacuum system is pressurized. Use the type of clamps which are suited to overpressure.

**DANGER**

**DANGER:** overpressure in the vacuum system >2.5 bar

KF flange connections with elastomer seals (e.g. O-rings) cannot withstand such pressures. Process media can thus leak and possibly damage your health.

Use O-rings provided with an outer centering ring.

**DANGER**

**DANGER:** protective ground

Products that are not professionally connected to ground can be extremely hazardous in the event of a fault.

The transmitter must be electrically connected to the grounded vacuum chamber. The connection must conform to the requirements of protective connection according to EN 61010:

- CF connections fulfill this requirement.
- For transmitters with KF connections, use a conductive metallic clamping ring.

**Caution**

**Caution:** vacuum component

Dirt and damages impair the function of the vacuum component.

When handling vacuum components, take appropriate measures to ensure cleanliness and prevent damages.

**Caution**

**Caution:** dirt sensitive area

Touching the product or parts thereof with one's bare hands increases the desorption rate.

Always wear clean, lint-free gloves and use clean tools when working in this area.

# Installation



## WARNING



WARNING: electric arcing

Helium may cause electric arcing with detrimental effects on the electronics of the product.

Before performing any tightness tests put the product out of operation and remove the electronics unit.



The transmitter may be mounted in any orientation. To keep condensates and particles from getting into the measuring chamber preferably choose a horizontal to upright position and possibly use a seal with a centering ring and filter.



If adjustment should be possible after the transmitter has been installed, be sure to install it so that potentiometers <HV> and <ATM> can be accessed with a screwdriver (→ "Adjusting the Transmitter").

## Procedure

Remove the protective lid and install the product at the vacuum system.

When making a CF flange connection, it can be advantageous to temporarily remove the electronics and the magnet unit (→ 11).

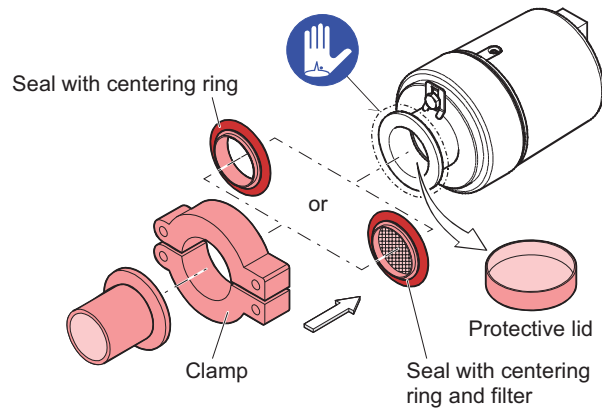

Keep the protective lid.

# Installation

## 3.1.1 Removing the Magnet Unit (Only for Transmitters With CF Flange)

### Tools required

- Allen wrench AF 1.5
- Open-end wrench AF 7

### Procedure

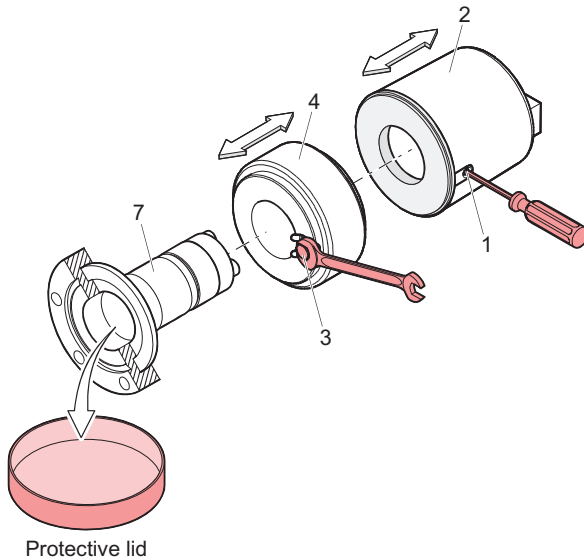

- Unfasten the hexagon socket set screw (1) on the side of the electronics unit (2).
- Remove the electronics unit **without twisting it**.
- Unfasten the hexagon head screw (3) on the magnet unit (4) and remove the magnet unit.



The magnetic force and the tendency to tilt make it difficult to separate the magnet unit and the measuring chamber (7).

- Make the flange connection between the transmitter and the vacuum system.
- Remount the magnet unit and lock it with the hexagon head screw (3).
- Carefully mount the electronics unit (2). (Make sure the pin of the Pirani element is properly plugged into the corresponding hole of the electronics unit.)
- Push the electronics unit up to the mechanical stop and lock it with the hexagon socket set screw (1).

# Installation

## 3.2 Electrical Connection

### Precondition

Make sure the vacuum connection is properly made (→ "Vacuum Connection").

### 3.2.1 Use With an Oerlikon Leybold Vacuum Controller

Connect the transmitter to the controller using a sensor cable.

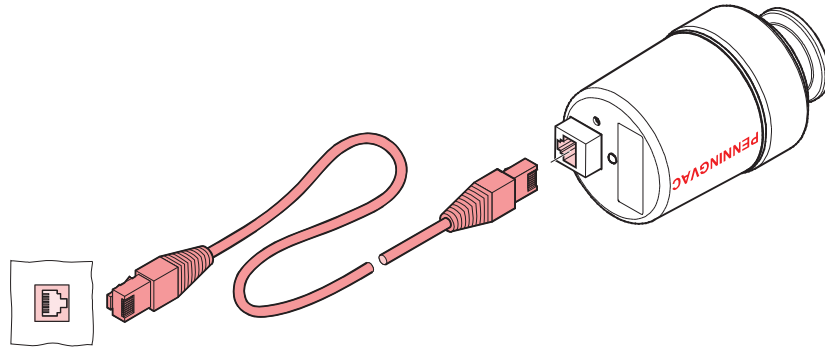

### 3.2.2 Use With Another Control Device

- 1 Make a sensor cable according to the following diagram.

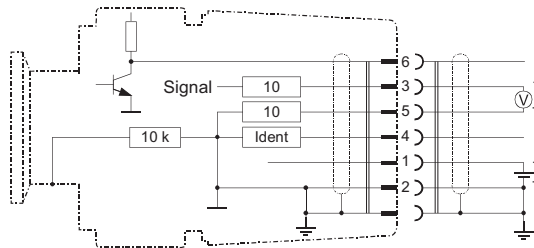

#### Electrical connection

- Pin 1 Supply (15 ... 30 VDC)
- Pin 2 Supply common
- Pin 3 Signal output (measuring signal)
- Pin 4 Identification
- Pin 5 Signal common
- Pin 6 Status
- Pin 7, 8 n.c.

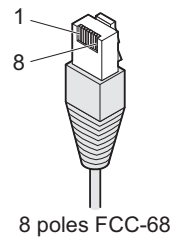

- 2 Connect the transmitter to the controller using the sensor cable.

## 4 Operation

As soon as the required supply voltage is applied, the measuring signal is available between pins 3 and 5. (→ § 26 for the relationship between the measuring signal and the pressure).

Allow for a stabilizing time of approx. 10 min. Once the transmitter has been switched on, permanently leave it on irrespective of the pressure.

### 4.1 Principle, Measuring Behavior

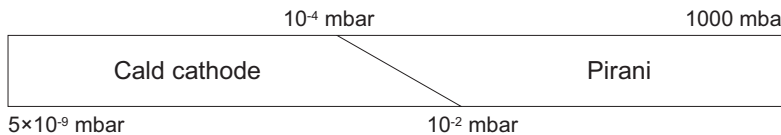

The transmitter consists of two separate measurement systems (Pirani and cold cathode system) the signals of which are combined in such a way that one measurement signal is output.

The optimum measuring configuration for the particular pressure range, in which measurement is performed, is used:



- The Pirani measuring circuit is always on.
- The cold cathode measuring circuit is controlled by the Pirani circuit and is activated only at pressures  $< 1 \times 10^{-2}$  mbar.

The status output (pin 6) indicates the current status of the transmitter.

Pressure	Green lamp on the transmitter	Operating mode	Pin 6
$p > 1 \times 10^{-2}$ mbar		Pirani-only mode	Low = 0 V
$p < 1 \times 10^{-2}$ mbar		Cold cathode not ignited Pirani-only mode	Low = 0 V
$p < 1 \times 10^{-2}$ mbar		Cold cathode ignited Combined Pirani / cold cathode mode	High = 15 ... 30 VDC

As long as the cold cathode measuring circuit has not ignited, the measuring value of the Pirani is output as measuring signal (if  $p < 5 \times 10^{-4}$  mbar, "Pirani underrange" is displayed).

### Gas type dependence

The measuring signal depends on the type of gas being measured. The curves are accurate for  $N_2$ ,  $O_2$ , dry air and CO. They can be mathematically converted for other gases (→ § 28).

If you are using an Oerlikon Leybold Vacuum controller, you can enter a calibration factor to correct the pressure reading (→ § of that controller).

### Ignition delay

When cold cathode measuring systems are activated, an ignition delay occurs. The delay time increases at low pressures and is typically:

- $10^{-5}$  mbar  $\approx$  1 second
- $10^{-7}$  mbar  $\approx$  20 seconds
- $5 \times 10^{-9}$  mbar  $\approx$  2 minutes

# Operation

As long as the cold cathode measuring circuit has not yet ignited, the measured value of the Pirani is output as measuring signal ("Pirani underrange" is displayed for pressures  $<5 \times 10^{-4}$  mbar). The status output (pin 6, low) indicates the Pirani-only mode.



If the transmitter is activated at a pressure  $p < 3 \times 10^{-9}$ , the transmitter cannot recognize whether the cold cathode system has ignited. It indicates "Pirani underrange".



Once flanged on, permanently leave the transmitter in the operating mode irrespective of the pressure range. Like this, the ignition delay of the cold cathode measuring circuit is always negligible ( $<1$  s), and thermal stabilizing effects are minimized.

## Contamination



Transmitter failures due to contamination, as well as expendable parts (filament), are not covered by the warranty.

Transmitter contamination is influenced by the process media used as well as by any present or new contaminants and their respective partial pressures. Continuous operation in the range of  $10^{-4}$  mbar ...  $10^{-2}$  mbar can cause severe contamination as well as reduced up-time and maintenance cycles. With constantly low pressures ( $p < 1 \times 10^{-6}$  mbar), the transmitter can be operated for more than one year without cleaning (cleaning the transmitter → 18).

Contamination of the transmitter generally causes a deviation of the measured values:

- In the high pressure range ( $1 \times 10^{-3}$  mbar ... 0.1 mbar), the pressure reading is too high (contamination of the Pirani element). Readjustment of the Pirani measuring system → 16.
- In the low pressure range ( $p < 1 \times 10^{-3}$  mbar), the pressure reading is usually too low (contamination of the cold cathode system). In case of severe contamination, instabilities can occur (layers of the measuring chamber peel off). Contamination due to insulation layers can even lead to a complete failure of the discharge ("Underrange" is displayed).

Contamination can to a certain extent be reduced by:

- geometric protection measures (e.g. screenings, elbows) for particles that spread rectilinearly
- mounting the flange of the transmitter at a place where the partial pressure of the pollutants is particularly low.

Special precautions are required for vapors deposited under plasma (of the cold cathode measuring system). It may even be necessary to temporarily switch of the transmitter while such vapors occur.

# Deinstallation

## 5 Deinstallation

### DANGER



DANGER: contaminated parts

Contaminated parts can be detrimental to health and environment. Before beginning to work, find out whether any parts are contaminated. Adhere to the relevant regulations and take the necessary precautions when handling contaminated parts.



### Caution



Caution: vacuum component

Dirt and damages impair the function of the vacuum component. When handling vacuum components, take appropriate measures to ensure cleanliness and prevent damages.



### Caution



Caution: dirt sensitive area

Touching the product or parts thereof with one's bare hands increases the desorption rate.

Always wear clean, lint-free gloves and use clean tools when working in this area.

## Procedure

- 1** Vent the vacuum system.
- 2** Put the transmitter out of operation and unplug the sensor cable.
- 3** Remove the transmitter from the vacuum system and place the protective lid.



When deinstalling a CF flange connection, it can be advantageous to temporarily remove the electronics and the magnet unit (→ 11).

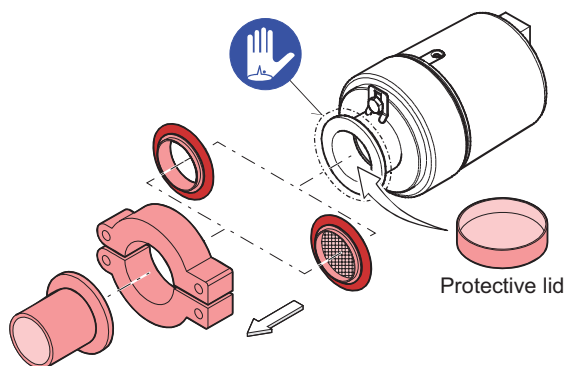

# Maintenance

## 6 Maintenance



Transmitter failures due to contamination, as well as expendable parts (filament), are not covered by the warranty.

### DANGER



DANGER: contaminated parts

Contaminated parts can be detrimental to health and environment. Before beginning to work, find out whether any parts are contaminated. Adhere to the relevant regulations and take the necessary precautions when handling contaminated parts.

### Caution



Caution: vacuum component

Dirt and damages impair the function of the vacuum component. When handling vacuum components, take appropriate measures to ensure cleanliness and prevent damages.

### Caution



Caution: dirt sensitive area

Touching the product or parts thereof with one's bare hands increases the desorption rate.

Always wear clean, lint-free gloves and use clean tools when working in this area.

### 6.1 Adjusting the Transmitter

The transmitter is factory-calibrated. If used under different climatic conditions, through extreme temperatures, aging or contamination, and after exchanging the sensor, the characteristic curve can be offset and readjustment may become necessary.

The cold cathode measurement circuit, which is dominant for low pressures ( $<1 \times 10^{-3}$  mbar), is factory-calibrated. By way of contrast, the Pirani measurement circuit can be adjusted. Any adjustment has a negligible effect on the pressure range between approx.  $10^{-2}$  mbar and  $10^2$  mbar.

#### Tools required

- Screw driver No. 1.5 mm
- Cylindrical pin  $\varnothing \approx 3$  mm

#### Procedure

- 1 If you are using a seal with centering ring and filter, check that they are clean or replace them if necessary (→ "Deinstallation").
- 2 Activate the transmitter (if possible, in the position, in which it will be used later on).
- 3 Evacuate it to  $p \ll 10^{-4}$  mbar, and then wait 10 minutes.

# Maintenance

- 4 Turn the nameplate counter-clockwise until the mechanical stop is reached.

5

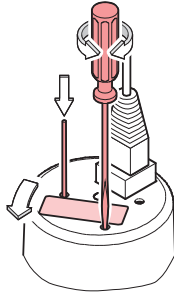

While depressing the tactile switch with a cylindrical pin ( $\varnothing \approx 3 \text{ mm}$ ), adjust the <HV> potentiometer by means of a 1.5 mm screwdriver ...

... to 4.20 V

or

... to  $5 \times 10^{-4}$  mbar.

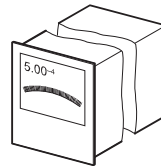
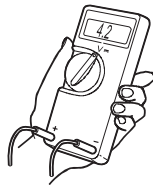

After that, turn the potentiometer counter-clockwise by 1/3 of a turn.

- 6 Vent the transmitter with air or nitrogen to atmospheric pressure, and wait at least 10 minutes.

- 7 Turn the nameplate clockwise until the mechanical stop is reached.

8

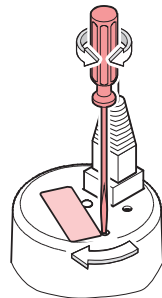

Using the 1.5 mm screwdriver, adjust the <ATM> potentiometer ...

... to 8.60 V

or

... to  $1 \times 10^3$  mbar.

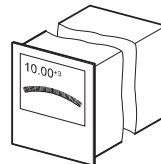
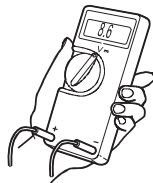

- 9 Turn the nameplate back to its original position (it catches).

# Maintenance

## 6.2 Cleaning the Transmitter, Replacing Parts



**DANGER**



**DANGER: cleaning agents**

Cleaning agents can be detrimental to health and environment.

Adhere to the relevant regulations and take the necessary precautions when handling and disposing of cleaning agents.



We recommend replacing the Pirani element when cleaning the transmitter.

### Tools / material required

- Allen wrench AF 1.5
- Allen wrench AF 3
- Open-end wrench AF 7
- Pliers for circlip
- Polishing cloth (400 grain) or Scotch-Brite
- Tweezers
- Cleaning alcohol
- Mounting tool for ignition aid
- Ignition aid
- Pirani element (13) incl. FPM seal (13a)
- FPM seal (11) for anode feedthrough

### 6.2.1 Disassembling the Transmitter

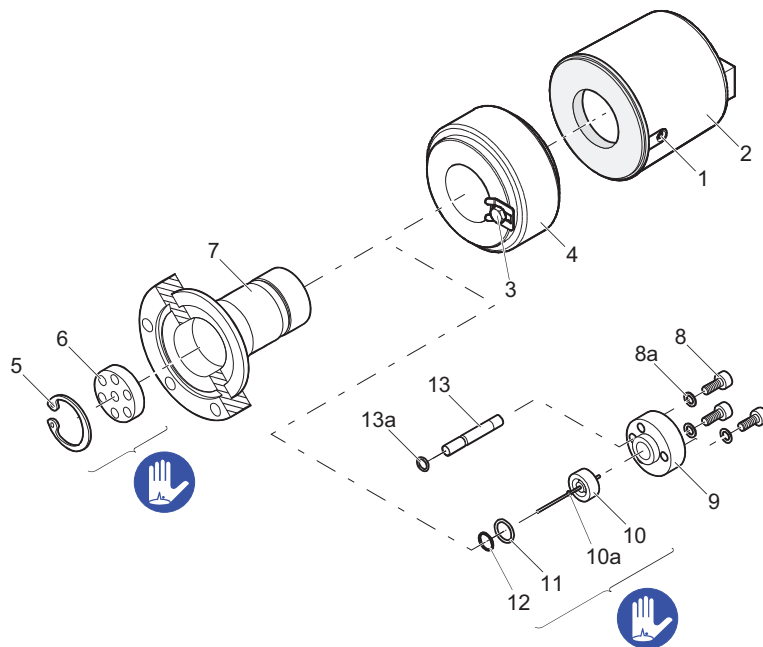

**1**

Remove the transmitter from the vacuum system (→ 15).

# Maintenance

2 Unfasten the hexagon socket set screw (1) on the side of the electronics unit (2).

3 Remove the electronics unit **without twisting it**.



The cover of the electronics unit cannot be removed.

4 Unfasten the hexagon head screw (3) on the magnet unit (4) and remove the magnet unit.



The magnetic force and the tendency to tilt make it difficult to separate the magnet unit and the measuring chamber (7).

5 Remove the circlip (5) and the polarity insert (6) from the measuring chamber.

6 Remove the three hexagon socket screws (8) incl. lock washers (8a) on the back of the measuring chamber.

7 Carefully remove the following parts in this order (without exerting stress on the Pirani element (13)): pressure piece (9), complete anode (10), FPM seal (11) incl. support ring (12), Pirani element (13) incl. FPM seal (13a).

The parts can now be cleaned or replaced individually.

## 6.2.2 Cleaning the Transmitter

### Cleaning the measuring chamber and the polarity insert

1 Using a polishing cloth rub the inside walls of the measuring chamber and the polarity insert to a bright finish.



The sealing surfaces must only be worked concentrically.

2 Rinse the measuring chamber and the polarity insert with cleaning alcohol.

3 Allow both to dry.

### Cleaning or replacing the anode

1 Remove the used ignition aid (10a) with pliers.

2 Using a polishing cloth rub the anode pin to a bright finish.



Do not bend the anode. Do not carry out mechanical work on the ceramic part.

3 Rinse the anode with cleaning alcohol.

4 Allow the anode to dry.

# Maintenance

5 Insert a new ignition aid (10a) into the mounting tool.

6 Carefully press the anode (clean or new) centered and parallel to the tool axis into the ignition aid and insert it to a depth of approx. 15 mm. The final positioning is established after the anode is installed.

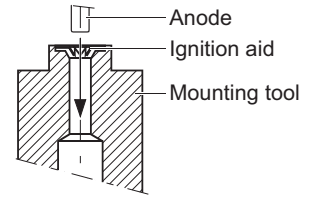

## Cleaning the Pirani element

- 1 Remove the FPM seal (13a) from the Pirani element (13).
- 2 Fill the Pirani measuring tube with cleaning alcohol and let it work.
- 3 Pour the alcohol out of the tube.
- 4 Dry the tube (e.g. with a blow dryer <math><150\text{ }^\circ\text{C}</math>).
- 5 Slide a new FPM seal over the Pirani element and insert it into the corresponding groove.
- 6 Reinstall the Pirani element (→ section 6.2.3).

## Replacing the Pirani element



If it is severely contaminated or defective.

- 1 Slide a new FPM seal (13a) over the Pirani element (13) and insert it into the corresponding groove.
- 2 Mount the Pirani element (→ section 6.2.3).

## 6.2.3 Reassembling the Transmitter

- 1 Insert the FPM seal (11) with the support ring (12) centered into the measuring chamber (7). The sealing surface, seal, and ceramic part must be clean.
- 2 Carefully insert the anode (10) incl. ignition aid (10a) into the measuring chamber.
- 3 Insert the Pirani element (13) with the FPM seal (13a) slid over it into the corresponding bore hole.
- 4 Carefully place the pressure piece (9) on the measuring chamber and tighten them with the three hexagon socket screws (8) incl. lock washers (8a) uniformly until the stop position is reached.
- 5 Position the ignition aid (10a) by pushing the mounting tool over the anode pin until the mechanical stop is reached.

# Maintenance

- 6 Blow the particles in the measuring chamber with dry nitrogen (be careful to hold the measuring chamber with the flange pointing downwards).
- 7 Slide the polarity insert (6) into the measuring chamber until the mechanical stop is reached.
- 8 Place the circlip (5) snugly fitting on the polarity insert.



Visually check that the anode pin is centered over the middle hole of the polarity insert (max. eccentricity = 0.5 mm).

- 9 If possible perform a leak test (leak rate  $<10^{-9}$  mbar l/s).

**WARNING**

WARNING: electric arcing  
Helium may cause electric arcing with detrimental effects on the electronics of the product.  
Before performing any tightness tests put the product out of operation and remove the electronics unit.

- 10 Mount the magnet unit (4) and lock it with the screw (3).
- 11 Carefully mount the electronics unit (2). (Make sure the pin of the Pirani element is properly plugged into the corresponding hole of the electronics unit.)
- 12 Push the electronics unit up to the mechanical stop and lock it with the hexagon socket set screw (1).
- 13 Adjust the transmitter (→ 16).

# Maintenance

## 6.3 Troubleshooting

Problem	Possible cause	Remedy
Measuring signal continually <0.5 V "Error low".	No supply voltage.	Turn on the power supply.
Measuring signal continually >9.5 V "Error high".	Pirani measurement element defective (filament rupture).	Replace the Pirani element (→ 20).
	Electronics unit not correctly mounted.	Mount the electronics unit correctly (→ 20).
The green lamp is ON and the status indicates Pirani-only mode (measuring signal continually >4.0 V) "Pirani underrange".	The cold cathode discharge has not ignited.	Wait until the gas discharge ignites (in case of contamination with insulation layers, the cold cathode may completely fail to ignite). (Cleaning → 18).
	The transmitter has only been activated at $p < 3 \times 10^{-9}$ mbar	Slightly increase the pressure.
Measuring signal continually >5 V or display $>10^{-3}$ mbar although vacuum pressure is OK.	Pirani measuring circuit not adjusted, e.g. due to severe contamination.	Readjust the Pirani measuring circuit (→ 16). If adjustment is impossible, replace the Pirani element.
	Measurement of heavy gases.	Convert with the corresponding formula (→ 28).
	Severe outgassing in the measuring chamber.	Clean the measuring chamber.
Measuring signal unstable.	Transmitter contaminated.	Clean the transmitter (→ 26).

# Accessories, Spare Parts

## 7 Accessories

When ordering accessories, always mention:

- all information on the product nameplate
- description and ordering number according to the accessories list

Description	Ordering number
Magnetic shielding	230 073

## 8 Spare Parts

When ordering spare parts, always mention:

- all information on the product nameplate
- description and ordering number according to the spare parts list

Pos.	Description	Ordering number
12	Maintenance kit, consisting of:	240 011
13a	1× support ring	
11	1× O-ring FPM $\varnothing 3.69 \times 1.78$	
10a	1× O-ring FPM $\varnothing 10.82 \times 1.78$	
	3× ignition aid	
13	Repair kit, consisting of:	240 010
12	1× Pirani element	
13a	1× support ring	
11	1× O-ring FPM $\varnothing 3.69 \times 1.78$	
10a	1× O-ring FPM $\varnothing 10.82 \times 1.78$	
10a	3× ignition aid	
10	1× anode, complete	
10a	Set of ignition aids, comprising:	240 012
	10× ignition aid	
	Mounting tool for ignition aid	240 013
	Measuring system	
	DN 25 ISO-KF flange	240 014
	DN 40 ISO-KF flange	240 015
	DN 40 CF-F flange	240 016

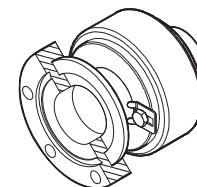
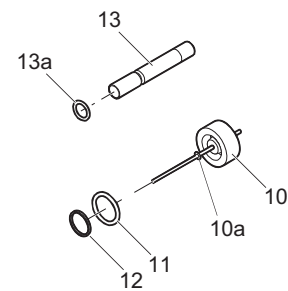

# Returning the Product

## 9 Returning the Product

**WARNING**





**WARNING: forwarding contaminated products**  
Contaminated products (e.g. radioactive, toxic, caustic or microbiological hazard) can be detrimental to health and environment.



Products returned to Oerlikon Leybold Vacuum should preferably be free of harmful substances. Adhere to the forwarding regulations of all involved countries and forwarding companies and enclose a duly completed declaration of contamination (→  30).

Products that are not clearly declared as "free of harmful substances" are decontaminated at the expense of the customer.

Products not accompanied by a duly completed declaration of contamination are returned to the sender at his own expense.

## 10 Disposal

	
	<p><b>DANGER: contaminated parts</b></p> <p>Contaminated parts can be detrimental to health and environment. Before beginning to work, find out whether any parts are contaminated. Adhere to the relevant regulations and take the necessary precautions when handling contaminated parts.</p>

	
	<p><b>WARNING: substances detrimental to the environment</b></p> <p>Products or parts thereof (mechanical and electric components, operating fluids etc.) can be detrimental to the environment. Dispose of such substances in accordance with the relevant local regulations.</p>

### Separating the components

After disassembling the product, separate its components according to the following criteria:

#### Contaminated components

Contaminated components (radioactive, toxic, caustic, or biological hazard etc.) must be decontaminated in accordance with the relevant national regulations, separated according to their materials, and disposed of.

#### Other components

Such components must be separated according to their materials and recycled.

# Appendix

## Appendix

### A: Relationship Between Measuring Signal and Pressure

#### Conversion formulae

$$p = 10^{1.667U-d} \Leftrightarrow U = c + 0.6 \log_{10} p$$

p	U	c	d
[mbar]	[V]	6.8	11.33
[Torr]	[V]	6.875	11.46
[Pa]	[V]	5.6	9.333

where p pressure                      valid in the range     $5 \times 10^{-9}$  mbar < p < 1000 mbar  
 U measuring signal                       $3.8 \times 10^{-9}$  Torr < p < 750 Torr  
 c, d constants (pressure                       $5 \times 10^{-7}$  Pa < p <  $1 \times 10^5$  pa  
 unit dependent)

#### Conversion curves

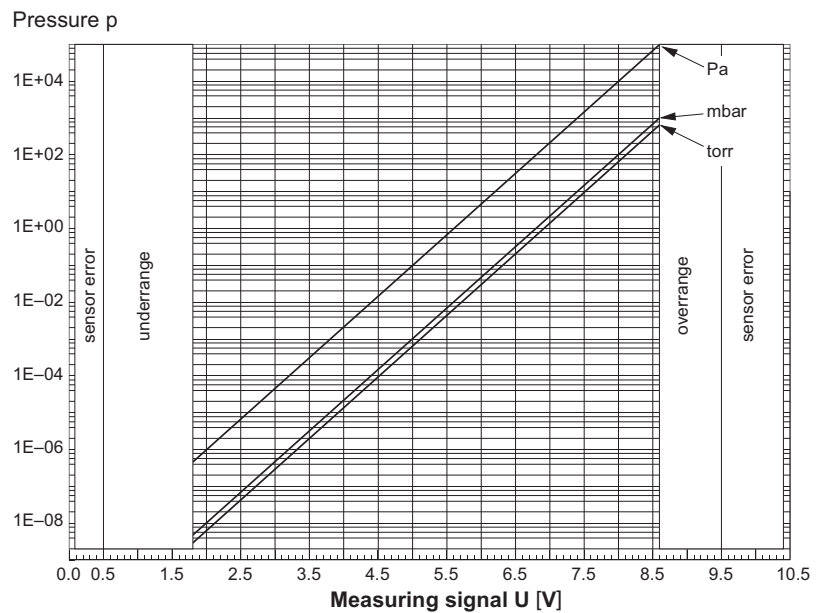

# Appendix

**Conversion table**

Measuring signal U [V]	[mbar]	Pressure p [Torr]	[Pa]
<0.5	Measuring system error		
0.5 ... 1.82	Underrange		
1.82	$5.0 \times 10^{-9}$	$3.8 \times 10^{-9}$	$5.0 \times 10^{-7}$
2.0	$1.0 \times 10^{-8}$	$7.5 \times 10^{-9}$	$1.0 \times 10^{-6}$
2.6	$1.0 \times 10^{-7}$	$7.5 \times 10^{-8}$	$1.0 \times 10^{-5}$
3.2	$1.0 \times 10^{-6}$	$7.5 \times 10^{-7}$	$1.0 \times 10^{-4}$
3.8	$1.0 \times 10^{-5}$	$7.5 \times 10^{-6}$	$1.0 \times 10^{-3}$
4.4	$1.0 \times 10^{-4}$	$7.5 \times 10^{-5}$	$1.0 \times 10^{-2}$
5.0	$1.0 \times 10^{-3}$	$7.5 \times 10^{-4}$	0.1
5.6	$1.0 \times 10^{-2}$	$7.5 \times 10^{-3}$	1.0
6.2	0.1	$7.5 \times 10^{-4}$	10
6.8	1.0	0.75	100
7.4	10	7.5	1000
8.0	100	75	$1.0 \times 10^4$
8.6	1000	750	$1.0 \times 10^5$
8.6 ... 9.5	Overrange		
9.5 ... 10.5	Measuring system error (Pirani defective)		

# Appendix

## B: Gas Type Dependence

### Indication range above $10^{-2}$ mbar (Pirani only mode)

Pressure reading (transmitter calibrated for air).

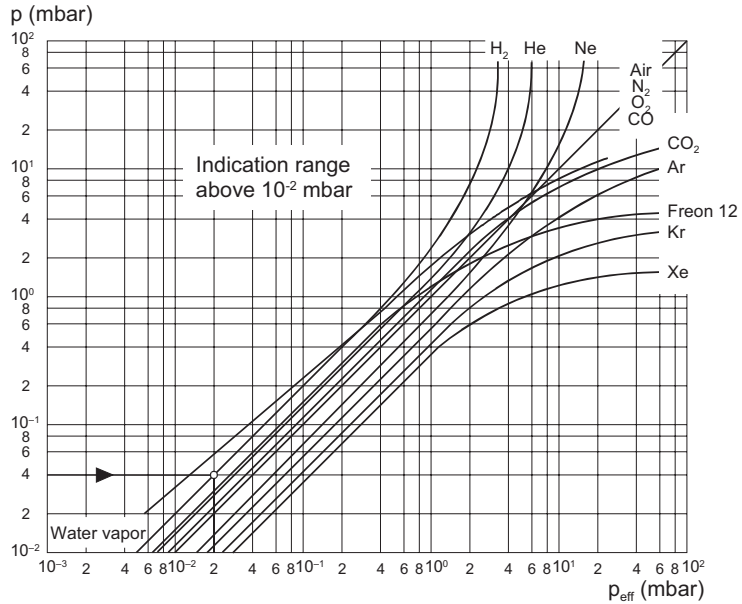

### Indication range $10^{-6}$ ... 0.1 mbar

Pressure reading (transmitter calibrated for air).

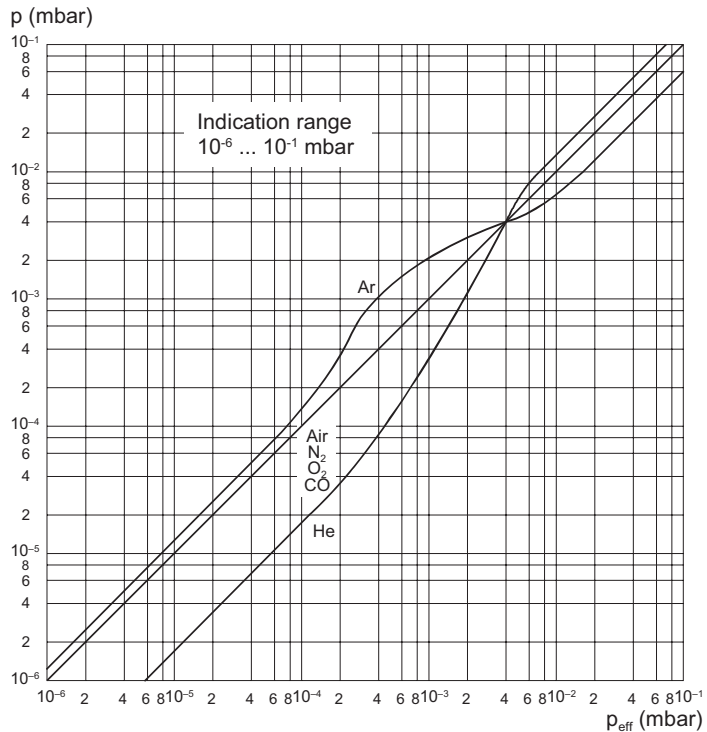

# Appendix

## Indication range below $10^{-5}$ mbar

In the range below  $10^{-5}$  mbar, the pressure indication is linear. For gases other than air, the pressure can be determined by means of a simple conversion formula:

$$p_{\text{eff}} = C \times \text{pressure reading}$$

where	Gas type	C
	Air (O <sub>2</sub> , CO, N <sub>2</sub> )	1.0
	Xe	0.4
	Kr	0.5
	Ar	0.8
	H <sub>2</sub>	2.4
	Ne	4.1
	He	5.9

These conversion factors are average values.



A mixture of gases and vapors is often involved. In this case, accurate determination is only possible with a partial pressure measurement instrument, e.g. a quadrupole mass spectrometer.

# Declaration of Contamination

## Declaration of Contamination



### Declaration of Contamination of Compressors, Vacuum Pumps and Components

The repair and / or servicing of compressors, vacuum pumps and components will be carried out only if a correctly completed declaration has been submitted. **Non-completion will result in delay.** The manufacturer can refuse to accept any equipment without a declaration. **A separate declaration has to be completed for every single component.**

This declaration may be completed and signed only by authorised and qualified staff.

Customer/Dep./Institute: _____	<b>Reason for return</b> <input checked="" type="checkbox"/> applicable please mark
Address: _____	<input type="checkbox"/> <b>Repair</b> <input type="checkbox"/> chargeable <input type="checkbox"/> warranty
Person to contact: _____	<input type="checkbox"/> <b>Exchange</b> <input type="checkbox"/> chargeable <input type="checkbox"/> warranty
Phone: _____ Fax: _____	<input type="checkbox"/> exchange already arranged / received
End user: _____	<b>Return only:</b> <input type="checkbox"/> rent <input type="checkbox"/> loan <input type="checkbox"/> for credit
	<b>Calibration:</b> <input type="checkbox"/> DKD <input type="checkbox"/> Factory calibration
	<input type="checkbox"/> Quality test certificate DIN 55350-18-4.2.1

<b>A. Description of the Leybold product</b>	Failure description: _____
Material description: _____	Additional parts: _____
Catalog number: _____	Application Tool: _____
Serial number: _____	Application Process: _____
Type of oil (Forevacuum pumps): _____	

<b>B. Condition of the equipment</b>						
	No <sup>1)</sup>	Yes	No	<b>Contamination:</b>	No <sup>1)</sup>	Yes
1. Has the equipment been used	<input type="checkbox"/>	<input type="checkbox"/>	<input checked="" type="checkbox"/>	toxic	<input type="checkbox"/>	<input type="checkbox"/>
2. Drained (Product/service fluid)	<input type="checkbox"/>	<input type="checkbox"/>	<input type="checkbox"/>	corrosive	<input type="checkbox"/>	<input type="checkbox"/>
3. All openings sealed airtight	<input type="checkbox"/>	<input type="checkbox"/>	<input type="checkbox"/>	flammable	<input type="checkbox"/>	<input type="checkbox"/>
4. Purged	<input type="checkbox"/>	<input type="checkbox"/>	<input type="checkbox"/>	explosive <sup>2)</sup>	<input type="checkbox"/>	<input type="checkbox"/>
If yes which cleaning agent: _____				radioactive <sup>2)</sup>	<input type="checkbox"/>	<input type="checkbox"/>
and which method of cleaning: _____				microbiological <sup>2)</sup>	<input type="checkbox"/>	<input type="checkbox"/>
<sup>1)</sup> if answered with "No" go to D.				other harmful substances	<input type="checkbox"/>	<input type="checkbox"/>

<b>C. Description of processed substances (Please fill in absolutely)</b>	
1. What substances have come into contact with the equipment: Trade name and / or chemical term of service fluids and substances processed, properties of the substances; According to safety data sheet (e.g. toxic, inflammable, corrosive, radioactive)	
Trade name: _____	Chemical name: _____
a) _____	
b) _____	
c) _____	
d) _____	
2. Are these substances harmful?	No <input type="checkbox"/> Yes <input type="checkbox"/>
3. Dangerous decomposition products when heated?	No <input type="checkbox"/> Yes <input type="checkbox"/>
If yes, which? _____	

<sup>2)</sup> Components contaminated by microbiological, explosive or radioactive products will not be accepted without written evidence of decontamination.

**D. Legally binding declaration**

I / we hereby declare that the information supplied on this form is accurate and sufficient to judge any contamination level.

Name of authorised person (block letters): \_\_\_\_\_

Date: \_\_\_\_\_ Signatur of authorised person: \_\_\_\_\_

Firm stamp

# Notes

# Sales and Service

## Germany

**Oerlikon**  
**Leybold Vacuum GmbH**  
Bonner Strasse 498  
D-50968 Cologne  
Phone: +49-(0)221-347 1234  
Fax: +49-(0)221-347 1245  
sales.vacuum@oerlikon.com

**Oerlikon**  
**Leybold Vacuum GmbH**  
**Sales Area North/East**  
Branch Office Berlin  
Buschkrugallee 33  
1. Obergeschoss  
D-12359 Berlin  
Phone: +49-(0)30-435 609 0  
Fax: +49-(0)30-435 609 10  
sales.vacuum.bn@oerlikon.com

**Oerlikon**  
**Leybold Vacuum GmbH**  
**Sales Area South/Southwest**  
Branch Office München  
Sendlinger Strasse 33  
D-80331 Munich  
Phone: +49-(0)89-357 33 9-10  
Fax: +49-(0)89-357 33 9-33  
sales.vacuum.mn@oerlikon.com  
service.vacuum.mn@oerlikon.com

**Oerlikon**  
**Leybold Vacuum GmbH**  
**Sales Area West & Benelux**  
Bonner Strasse 498  
D-50968 Cologne  
Phone: +49-(0)221-347 1270  
Fax: +49-(0)221-347 1291  
sales.vacuum.kn@oerlikon.com

**Oerlikon**  
**Leybold Vacuum GmbH**  
**Service Competence Center**  
Emil-Hoffmann-Strasse 43  
D-50996 Cologne-Sürth  
Phone: +49-(0)221-347 1439  
Fax: +49-(0)221-347 1945  
service.vacuum.kn@oerlikon.com

**Oerlikon**  
**Leybold Vacuum GmbH**  
**Mobile Customer Service**  
Emil-Hoffmann-Strasse 43  
D-50996 Cologne-Sürth  
Phone: +49-(0)221-347 1765  
Fax: +49-(0)221-347 1944  
service.vacuum.kn@oerlikon.com

**Oerlikon**  
**Leybold Vacuum GmbH,**  
**Dresden**  
Zur Wetterwarte 50, Haus 304  
D-01109 Dresden  
Service:  
Phone: +49-(0)351-88 55 00  
Fax: +49-(0)351-88 55 041  
info.vacuum.dr@oerlikon.com

## Europe

Belgium  
**Oerlikon**  
**Leybold Vacuum Nederland B.V.**  
**Belgisch bijkantoor**  
Leuvensesteenweg 542-9A  
B-1930 Zaventem  
Sales:  
Phone: +32-2-711 00 83  
Fax: +32-2-720 83 38  
sales.vacuum.zv@oerlikon.com  
Service:  
Phone: +32-2-711 00 82  
Fax: +32-2-720 83 38  
service.vacuum.zv@oerlikon.com

France  
**Oerlikon**  
**Leybold Vacuum France S.A.**  
7, Avenue du Québec  
Z.A. Courtaboeuf 1 - B.P. 42  
F-91942 Courtaboeuf Cedex  
Sales and Service:  
Phone: +33-1-69 82 48 00  
Fax: +33-1-69 07 57 38  
sales.vacuum.or@oerlikon.com

**Oerlikon**  
**Leybold Vacuum France S.A.**  
**Valence Factory**  
640, Rue A. Bergès - B.P. 107  
F-26501 Bourg-lès-Valence Cedex  
Phone: +33-4-75 82 33 00  
Fax: +33-4-75 82 92 69  
info.vacuum.vc@oerlikon.com

Great Britain  
**Oerlikon**  
**Leybold Vacuum UK LTD.**  
Unit 2  
Silverglade Business Park  
Leatherhead Road  
UK-Chessington, Surrey KT9 2QL  
Sales:  
Phone: +44-13-7273 7300  
Fax: +44-13-7273 7301  
sales.vacuum.ln@oerlikon.com  
Service:  
Phone: +44-20-8971 7030  
Fax: +44-20-8971 7003  
service.vacuum.ln@oerlikon.com

Italy  
**Oerlikon**  
**Leybold Vacuum Italia S.p.A.**  
8, Via Trasimeno  
I-20128 Milano  
Sales:  
Phone: +39-02-27 22 31  
Fax: +39-02-27 20 96 41  
sales.vacuum.mi@oerlikon.com  
Service:  
Phone: +39-02-27 22 31  
Fax: +39-02-27 22 32 17  
service.vacuum.mi@oerlikon.com

**Oerlikon**  
**Leybold Vacuum Italia S.p.A.**  
Field Service Base  
Z.I. Le Capanne  
I-05021 Acquasparta (TR)  
Phone: +39-0744-93 03 93  
Tel.: +39-0744-94 42 87  
service.vacuum.mi@oerlikon.com

**Oerlikon**  
**Leybold Vacuum Italia S.p.A.**  
Field Service Base  
Z.I. Le Capanne  
I-05021 Acquasparta (TR)  
Phone: +39-0744-93 03 93  
Tel.: +39-0744-94 42 87  
service.vacuum.mi@oerlikon.com

**Oerlikon**  
**Leybold Vacuum Italia S.p.A.**  
Field Service Base  
Z.I. Le Capanne  
I-05021 Acquasparta (TR)  
Phone: +39-0744-93 03 93  
Tel.: +39-0744-94 42 87  
service.vacuum.mi@oerlikon.com

Netherlands  
**Oerlikon**  
**Leybold Vacuum Nederland B.V.**  
Computerweg 7  
NL-3542 DP Utrecht  
Sales and Service:  
Phone: +31-346-58 39 99  
Fax: +31-346-58 39 90  
sales.vacuum.ut@oerlikon.com  
service.vacuum.ut@oerlikon.com

Spain  
**Oerlikon**  
**Leybold Vacuum Spain, S.A.**  
C/ Huelva, 7  
E-08940 Cornellà de Llobregat  
(Barcelona)  
Sales:  
Phone: +34-93-666 46 16  
Fax: +34-93-666 43 70  
sales.vacuum.ba@oerlikon.com  
Service:  
Phone: +34-93-666 49 51  
Fax: +34-93-685 40 10

Sweden  
**Oerlikon**  
**Leybold Vacuum Scandinavia AB**  
Box 9084  
SE-40092 Göteborg  
Sales and Service:  
Phone: +46-31-68 84 70  
Fax: +46-31-68 39 39  
info.vacuum.gt@oerlikon.com  
Visiting/delivery adress:  
Datavägen 57B  
SE-43632 Askim

Switzerland  
**Oerlikon**  
**Leybold Vacuum Schweiz AG**  
Leutschenbachstrasse 55  
CH-8050 Zürich  
Sales:  
Tel.: +41-44-308 40 50  
Fax: +41-44-302 43 73  
sales.vacuum.zh@oerlikon.com  
Service:  
Phone: +41-44-308 40 62  
Fax: +41-44-308 40 60

## America

USA  
**Oerlikon**  
**Leybold Vacuum USA Inc.**  
5700 Mellon Road  
Export, PA 15632  
Phone: +1-724-327-5700  
Fax: +1-724-325-3577  
info.vacuum.ex@oerlikon.com  
Sales:  
Eastern & Central time zones  
Phone: +1-724-327-5700  
Fax: +1-724-733-1217  
Pacific, Mountain, Alaskan & Hawaiian  
time zones  
Phone: +1-480-752-9191  
Fax: +1-480-752-9494  
Service:  
Phone: +1-724-327-5700  
Fax: +1-724-733-3799

## Asia

P.R. China  
**Oerlikon**  
**Leybold Vacuum (Tianjin)**  
**International Trade Co., Ltd.**  
Beichen Economic  
Development Area (BEDA),  
Shanghai Road  
Tianjin 300400  
China  
Sales and Service:  
Phone: +86-22-2697 0808  
Fax: +86-22-2697 4061  
Fax: +86-22-2697 2017  
sales.vacuum.tj@oerlikon.com

**Oerlikon**  
**Leybold Vacuum**  
**(Tianjin) Co., Ltd.**  
Beichen Economic  
Development Area (BEDA),  
Shanghai Road  
Tianjin 300400  
China  
Sales and Service:  
Phone: +86-22-2697 0808  
Fax: +86-22-2697 4061  
Fax: +86-22-2697 2017  
info.vacuum.tj@oerlikon.com

**Oerlikon**  
**Leybold Vacuum (Tianjin)**  
**International Trade Co., Ltd.**  
Shanghai Branch:  
Add: No.33,  
76 Futedong San Rd.  
Waigaoqiao FTZ  
Shanghai 200131  
China  
Sales and Service:  
Phone: +86-21-5064-4666  
Fax: +86-21-5064-4668  
info.vacuum.sh@oerlikon.com

**Oerlikon**  
**Leybold Vacuum (Tianjin)**  
**International Trade Co., Ltd.**  
Guangzhou Office and  
Service Center  
1st F, Main Building,  
Science City Plaza,  
No.111 Science Revenue,  
Guangzhou Science City,  
(GZSC) 510663 Guangzhou,  
China  
Sales:  
Phone: +86-20-22323980  
Fax: +86-20-22323990  
info.vacuum.gz@oerlikon.com

**Oerlikon**  
**Leybold Vacuum (Tianjin)**  
**International Trade Co., Ltd.**  
Beijing Branch:  
1-908, Beijing Landmark Towers  
8 North Dongsanhuan Road  
Chaoyang District  
Beijing 100004  
China  
Sales:  
Phone: +86-10-6590-7622  
Fax: +86-10-6590-7607

India  
**Oerlikon**  
**Leybold Vacuum India Pvt Ltd.**  
El-22, J Block  
MIDC Bhosari  
Pune 411026  
India  
Sales:  
Phone: +91-20-3061 60000  
Fax: +91-20-2712 1571  
sales.vacuum.pu@oerlikon.com

Japan  
**Oerlikon**  
**Leybold Vacuum**  
**Japan Co., Ltd.**  
Head Office  
Tobu A.K. Bldg. 4th Floor  
23-3, Shin-Yokohama  
3-chome  
Kohoku-ku, Yokohama-shi  
Kanagawa-ken 222-0033  
Sales:  
Phone: +81-45-471-3330  
Fax: +81-45-471-3323

**Oerlikon**  
**Leybold Vacuum**  
**Japan Co., Ltd.**  
Osaka Sales Office  
5-13, Kawagishi-cho  
Suita-chi  
Osaka-fu  
Phone: +81-6-4860-2212  
Fax: +81-45-471-3323

**Oerlikon**  
**Leybold Vacuum**  
**Japan Co., Ltd.**  
Tsukuba Technical S.C.  
Tsukuba Minami Daiichi  
Kogyo Danchi  
21, Kasumi-no-Sato,  
Ami-machi, Inashiki-gun  
Ibaraki-ken, 300-0315  
Service:  
Phone: +81-29-889-2841  
Fax: +81-29-889-2838

Korea  
**Oerlikon**  
**Leybold Vacuum Korea Ltd.**  
#761-4, Yulkeum-ri  
SungHwan-eup, Cheonan-City  
Choongchung-Namdo  
330-807, Korea  
Sales:  
Tel.: +82-41-580-4420  
Fax: +82-41-588-3737  
Service:  
Tel.: +82-41-580-4415  
Fax: +82-41-588-3737

Singapore  
**Oerlikon**  
**Leybold Vacuum**  
**Singapore Pte Ltd.**  
1 Science Park Road  
Singapore Science Park 2  
#02-12 Capricorn Building  
Singapore 117528  
Sales and Service:  
Phone: +65-6303 7000  
Fax: +65-67730 039  
info.vacuum.sg@oerlikon.com

Taiwan  
**Oerlikon**  
**Leybold Vacuum Taiwan Ltd.**  
No 416-1, Sec. 3  
Chung-Hsin Rd., Chu-Tung  
Hsin-Chu, Taiwan, R.O.C.  
Sales and Service:  
Phone: +886-3-500 1688  
Fax: +886-3-583 3999  
sales.vacuum.hc@oerlikon.com

**Oerlikon**  
**Leybold Vacuum GmbH**  
Bonner Strasse 498  
D-50968 Köln  
Tel: +49-(0)221-347 1234  
Fax: +49-(0)221-347 1245  
documentation.vacuum@oerlikon.com

**oerlikon**  
leybold vacuum

www.oerlikon.com

Original: German GA09313\_0202 (2008-02)



ga09313\_0202