

IONIVAC

ITR 90
ITR 90 P

Instruction Sheet KA 09.420/3.02
Incl. Declaration of Conformity

Part Numbers

120 90
120 91
120 92
120 94
230 030
230 031

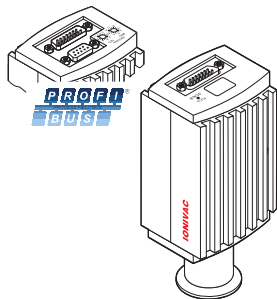

Product Identification

In all communications with Oerlikon Leybold Vacuum, please specify the information given on the product nameplate. For convenient reference transfer this information into the diagram below.

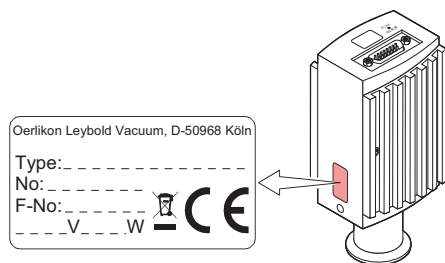

Validity

This document applies to products with the following part numbers:

ITR 90 Without display:
120 90 (DN 25 ISO-KF)
120 92 (DN 40 CF-R)

ITR 90 With display
120 91 (DN 25 ISO-KF)
120 94 (DN 40 CF-R)

ITR 90 P (with Profibus interface and switching functions)
230 030 (DN 25 ISO-KF)
230 031 (DN 40 CF-R)

The part number (No) can be taken from the product name plate.

If not indicated otherwise in the legends, the illustrations in this document correspond to the gauge with part number 120 90. They apply to the other gauges by analogy.

We reserve the right to make technical changes without prior notice.

All dimensions in mm.

Intended use

The Hot Ion Combi Gauges ITR 90 and ITR 90 P have been designed for vacuum measurement of non-flammable gases and gas mixtures in a pressure range $5 \times 10^{-10} \dots 1000$ mbar.

The gauges can be operated in connection with the COMBIVAC® IT23 or with another evaluation unit.

Functional Principle

Over the whole measurement range, the Hot Ion Combi Gauges have a continuous characteristic curve and its measuring signal is output as logarithm of the pressure.

The gauge functions with a Bayard Alpert hot cathode ionization measurement system (for $p < 2.0 \times 10^{-2}$ mbar) and a Pirani measurement system (for $p > 5.5 \times 10^{-3}$ mbar). In the overlapping pressure range of $2.0 \times 10^{-2} \dots 5.5 \times 10^{-3}$ mbar a mixed signal of the two measurement systems is output. The hot cathode is switched on by the Pirani measurement system only below the switching threshold of 2.4×10^{-2} mbar (to prevent filament burn-out). It is switched off when the pressure exceeds 3.2×10^{-2} mbar.

Trademark

COMBIVAC® Oerlikon Leybold Vacuum

Safety

Symbols Used

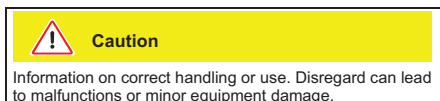
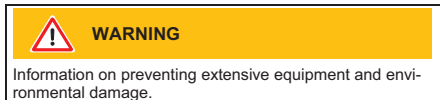

Personnel Qualifications

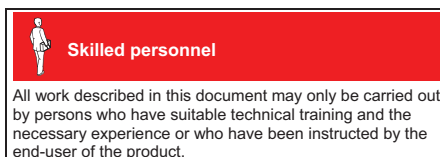

General Safety Instructions

- Adhere to the applicable regulations and take the necessary precautions for the process media used. Consider possible reactions with the product materials. Consider possible reactions (e.g. explosion) of the process media due to the heat generated by the product.
- Adhere to the applicable regulations and take the necessary precautions for all work you are going to do and consider the safety instructions in this document.
- Before beginning to work, find out whether any vacuum components are contaminated. Adhere to the relevant regulations and take the necessary precautions when handling contaminated parts.

Communicate the safety instructions to all other users.

Liability and Warranty

Oerlikon Leybold Vacuum assumes no liability and the warranty becomes null and void if the end-user or third parties

- disregard the information in this document
- use the product in a non-conforming manner
- make any kind of changes (modifications, alterations etc.) to the product
- use the product with accessories not listed in the product documentation.

The end-user assumes the responsibility in conjunction with the process media used.

Transmitter failures due to contamination or wear and tear as well as expendable parts (filaments) are not covered by the warranty.

Technical Data

In some points, the technical data of ITR 90 P differ from those of ITR 90, which are given below (→ "Technical Data" in [1] and [2]).

Measurement range (air, O ₂ , CO, N ₂)	$5 \times 10^{-10} \dots 1000$ mbar continuous
Accuracy	± 15% of reading in the range of $1 \times 10^{-8} \dots 10^{-2}$ mbar after 5 min. stabilization
Repeatability	± 5% of reading in the range of $1 \times 10^{-8} \dots 10^{-2}$ mbar after 5 min. stabilization

Emission switching on threshold	2.4×10^{-2} mbar
Emission switching off threshold	3.2×10^{-2} mbar
Emission current $p \leq 7.2 \times 10^{-6}$ mbar	5 mA
7.2×10^{-6} mbar $< p < 3.2 \times 10^{-2}$ mbar	25 µA
Emission current switching	
25 µA ⇒ 5 mA	7.2×10^{-6} mbar
5 mA ⇒ 25 µA	3.2×10^{-6} mbar

Degas current ($p < 7.2 \times 10^{-6}$ mbar)	≈ 16 mA / ≈ 4.0 W
control input signal	0 V / 24 V, PLC level, high active
duration	< 3 min, followed by automatic stop
In degas mode, the ITR 90 keeps supplying measurement values the tolerances of which can be higher than during normal operation.	

Output signal (measuring signal)	0 ... 10 V
Measuring range	0.774 V ... 10 V (5×10^{-10} mbar ... 1000 mbar)
Relationship voltage-pressure	logarithmic, 0.75 V / decade
Error signal	< 0.3 V / 0.5 V
Minimum loaded impedance	10 kΩ

Gauge identification	42 kΩ between Pin 10 and Pin 5 (gauge cable)
----------------------	--

RS232C interface	
baud rate	9600 baud
data format	binary data set 8 data bits one stop-bit no parity-bit no handshake
signal level	≈ ± 8 V
connector	→ Power connection

Further information on the RS232C interface → [1]

Display panel	LCD matrix, 32×16 pixels, with background illumination
dimensions	16.0 mm × 11.2 mm
measurement units	mbar (default), Torr, Pa
Choosing the measurement unit → [1]	

Supply

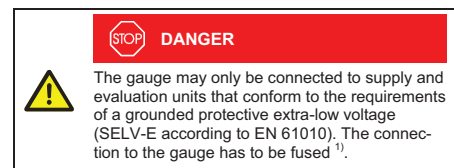

Voltage at gauge	24 VDC (20 ... 28 VDC) (ripple 2 V _{pp}) ²⁾
------------------	--

Power consumption	
standard	≤ 0.5 A
degas	≤ 0.8 A
emissions start (200 ms)	≤ 1.4 A
Power consumption	≤ 16 W
Fuse necessary ¹⁾	≤ 1.25 AT

¹⁾ Oerlikon Leybold Vacuum controllers fulfill these requirements.

²⁾ The minimum voltage of the power supply must be increased proportionally to the length of the measuring cable.

Electrical connection	Connection, D Sub 15 poles,
Sensor cable	
for analog values only without degas-function	4 poles plus screening
for analog values with degas-function	5 poles plus screening
all functions incl. RS232C interface	7 poles plus screening
Cable length (24 VDC)	≤35 m (4/5/7x0.25 mm ²) ≤50 m (4/5/7x0.34 mm ²) ≤100 m (4/5/7x1.0 mm ²)
For operation with RS232C interface	≤30 m

Materials on the vacuum side

housing, supports, screens	stainless steel
feedthrough	NiFe nickel plated
isolator	glass
cathode	Ir,Y ₂ O ₃
cathode holder	Mo
Pirani element	W, Cu
Internal volume	
120 90, 120 91, 230030	≈24 cm ³
120 92, 120 94, 230031	≈34 cm ³
Pressure	≤2 bar (absolute)

Admissible temperatures

storage	-20 ... +70 °C
operation	0 ... +50 °C
bake out	150 °C (without electronics unit)

Relative humidity

year's mean	≤65% (no condensation)
during 60 days	≤85% (no condensation)

Use

indoors only altitude up to 2000 m

Type of protection

IP 30

Dimensions

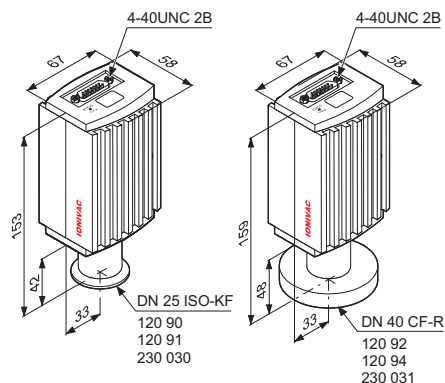

Weight

120 90, 120 91	285 g
120 92, 120 94	550 g
230030	430 g
230031	695 g

Measuring signal vs. pressure

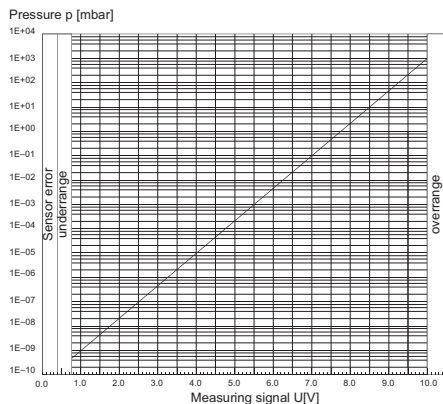

$$p = 10^{(U-7.75)/0.75+c}$$

U	p	c
[V]	[mbar]	0
[V]	[Pa]	2
[V]	[Torr]	-0.125

where p pressure
U measuring signal
c constant (pressure unit dependent)

Gas type dependence

For gases other than air, the pressure in the indication range $p < 10^{-3}$ mbar can be determined by a simple conversion:

$$p_{\text{eff}} = K \times \text{pressure indicated}$$

Gas type	Calibration factor C	Gas type	Calibration factor C
He	5.9	air, O ₂ , CO, N ₂	1.0
Ne	4.1	H ₂	2.4
Kr	0.5	Xe	0.4
Ar	0.8		

Installation

Vacuum Connection

STOP DANGER

Caution: overpressure in the vacuum system >1 bar

Injury caused by released parts and harm caused by escaping process gases can result if clamps are opened while the vacuum system is pressurized.

Do not open any clamps while the vacuum system is pressurized. Use the type clamps which are suited to overpressure.

STOP DANGER

Caution: protective ground

Incorrectly grounded products can be extremely hazardous in the event of a fault.

The gauge must be electrically connected to the grounded vacuum chamber. This connection must conform to the requirements of a protective connection according to EN 61010:

- CF connection fulfill this requirement
- For gauges with a KF flange, use a conductive metallic clamping ring

Caution

Caution: vacuum component

Dirt and damages impair the function of the vacuum component.

When handling vacuum components, take appropriate measures to ensure cleanliness and prevent damages.

Caution

Caution: dirt sensitive area

Touching the product or parts thereof with one's bare hands increases the desorption rate.

Always wear clean, lint-free gloves and use clean tools when working in this area.

The gauge may be mounted in any orientation. To keep condensates and particles from getting into the measuring chamber preferably choose a horizontal to upright position and possibly use a seal with a centering ring and filter.

The gauge is supplied with a built in grid. For potentially contaminating applications and to protect the electrodes against light and fast particles, installation of the optional baffle is recommended (→ [1]).

Remove the protective lid and install the product at the vacuum system.

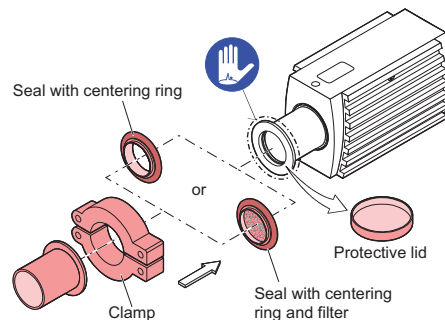

Keep the lid.

Power connection

The following information on the electrical connection as well as the wiring diagram applies to ITR 90 only (→ [1] and [2] for details on the electrical connection and additional functions of ITR 90 P).

Make sure the vacuum connection is properly made (→ "Vacuum Connection").

If no connection cable is available, make one according to the following diagram.

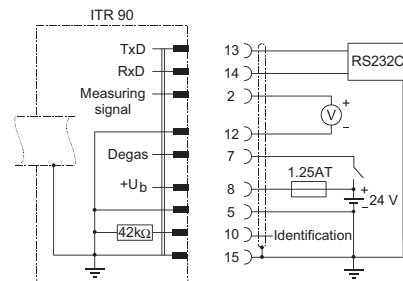

Electrical connection

Pin 2	Signal output (measuring signal)	0 ... +10 V
Pin 5	Supply common, GND	
Pin 7	Degas on, active high	+24 VDC
Pin 8	Supply	+24 VDC
Pin 10	Gauge identification	
Pin 12	Signal common, GND	
Pin 13	RS232C, TxD	
Pin 14	RS232C, RxD	
Pin 15	Shielding, housing, GND	

Pins 1, 3, 4, 6, 9 and 11 are not connected internally.

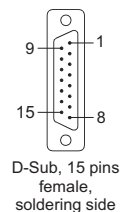

ka09.420/3.02

(2008-01)

- 2 Connect the sensor cable to the gauge.

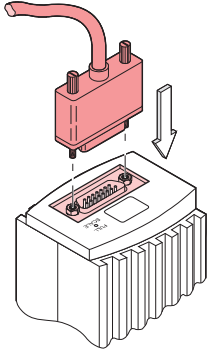

- 3 Secure the cable socket with the lock screws.

- 4 Connect the sensor cable to the controller.

- 3 Adjusting the gauge

ITR 90 Without display 120 90 120 91 | ITR 90 With display 120 92 120 94

Insert a pin ($\approx \varnothing 1.3 \times 50 \text{ mm}$) through the opening marked <FULL SCALE> and push the button inside for at least 5 seconds.

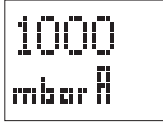
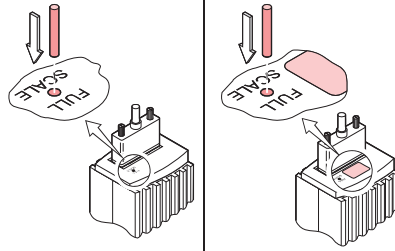

Adjustment proceeds automatically

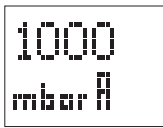

Adjustment terminated



no
Signal

Internal data connection failure
(red background illumination)

Deinstallation

STOP DANGER



Caution: contaminated parts

Contaminated parts can be detrimental to health and environment.

Before beginning to work, find out whether any parts are contaminated. Adhere to the relevant regulations and take the necessary precautions when handling contaminated parts.



Caution



Caution: vacuum component

Dirt and damages impair the function of the vacuum component.

When handling vacuum components, take appropriate measures to ensure cleanliness and prevent damages.



Caution



Caution: dirt sensitive area

Touching the product or parts thereof with one's bare hands increases the desorption rate.

Always wear clean, lint-free gloves and use clean tools when working in this area.

Operation

When the voltage is supplied, the measuring signal is available between pins 2 and 12. (Relationship between measuring signal and pressure → "Technical Data").

ITR 90 P can also be operated via the corresponding fieldbus interface (→ [1] and [2] for further details and functions).

Allow for a stabilizing time of ≈ 10 minutes. Once the gauge has been switched on, permanently leave it on irrespective of the pressure.

Gas type dependence

The measurement value is gas dependent. The display applies to dry air, O_2 , CO , and N_2 . For other gases, it has to be converted (→ "Technical data").

Adjusting the gauge



The adjustment of ITR 90 P (→ [1] and [2]) is slightly different from the procedure for ITR 90, which is described below.

The gauge is factory calibrated. If used under different climatic conditions or in a different position, through ageing or contamination and after exchanging the sensor, the characteristic curve can be offset and readjustment can become necessary. Only the Pirani element can be adjusted and only at atmosphere.

Readjustment becomes necessary if

- at atmosphere the output voltage is $< 10 \text{ V}$ or the display reading is $< \text{atmosphere}$
- when ventilating the vacuum system, the output voltage reaches 10 V before the measured pressure has reached atmosphere. (Gauges with display will show the error "5" at atmosphere (Pirani sensor warning).

- 1 If you are using a seal with centering ring and filter, check that they are clean or replace them if necessary.

- 2 Activate the gauge.



Operate the gauge for 10 minutes at atmospheric pressure. If the gauge was operated within Ioni range, a cooling-down time of approx. 30 minutes is to be expected (gauge temperature = environmental temperature).

Display

(Part numbers 120 91 and 120 94)

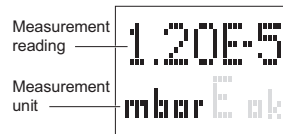

(none) Pirani operation
E Emission $25 \mu\text{A}$
E. Emission 5 mA
D Degas
fi 1000 mbar adjustment (Pirani)



ok no error
(green background illumination)
5 Pirani sensor warning
(red background illumination)
8 Pirani sensor error
(red background illumination)

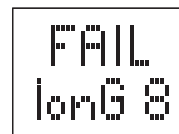

8 Ioni sensor error
(red background illumination)

- Vent the vacuum system.
- Turn the gauge off.
- Loose the lock screws and unplug the sensor cable (if you are using ITR 90 P unfasten and unplug the interface cable too (→ [1] and [2])).

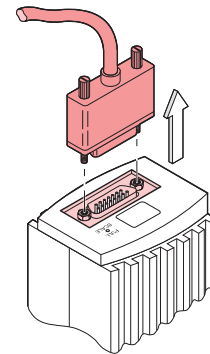

- 4 Remove the gauge from the vacuum system.

