

Condensate Separators AK 4-8, AK 16-25, AK 40-65



AK 4-8 condensate separator

Separators protect the pump against condensate.

Advantages to the User

- May be installed without accessories
- May be used either on the intake or the exhaust side
- Independent of the direction of flow
- Condensate level check via inspection glass
- Resists solvents
- All seals made of FPM
- Simple to clean
- Easy to use
- Drained via drain screw or drain tap

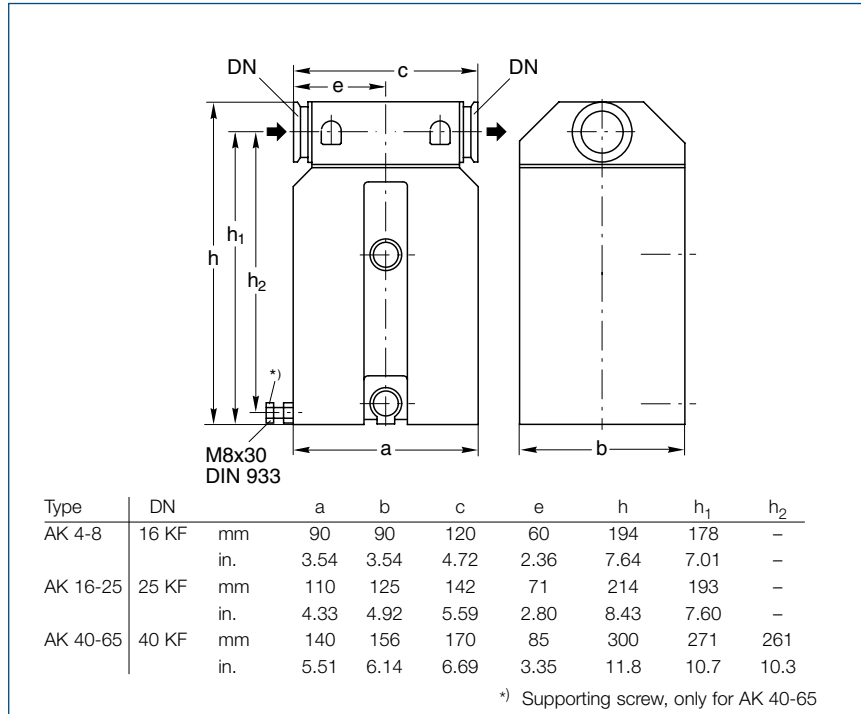

Dimensional drawing for the AK condensate separators

Typical Application

- Prevention of the collection of liquids in the intake line

Technical Information

Depending upon the layout and pipe run of an exhaust line, it may be necessary to install a separator to prevent condensate draining back to the pump.

Technical Data		AK 4-8	AK16-25	AK 40-65
Connection to pump	TRIVAC	D 4 B D 8 B	D 16 B/BCS (-PFPE) D 25 B/BCS (-PFPE)	D 40 B/BCS (-PFPE) D 65 B/BCS (-PFPE)
Capacity for condensate	l (qt)	0.66 (0.7)	1.2 (1.3)	3.0 (3.2)
Weight	kg (lbs)	1.7 (3.7)	2.4 (5.3)	5.5 (12.1)
Ordering Information		AK 4-8	AK16-25	AK 40-65
Condensate separator		Part No. 188 06	Part No. 188 11	Part No. 188 16
Oil Drain tap M 16 x 1.5 (vacuum-tight)		Part No. 190 90	Part No. 190 90	Part No. 190 90
Adaptor DN 16 KF – hose nozzle DN 7		Part No. 182 90	–	–