

COMBIVAC CM 51

Vacuum Gauge Controller

Instruction Manual GA130001441_002_C0

Catalog No.

230110

230111



0. Table of Contents

0.	Table of Contents	3
0.1	Table of Figures	7
0.2	Table of Tables	7
1.	Description	8
1.1	Validity	8
1.1.1	Part Number	8
1.1.2	Nameplate	8
1.2	Conforming Utilisation	8
1.3	Responsibility and Warranty	9
1.4	Shipping Damage	9
2.	Safety	10
2.1	General Information	10
2.2	Key to the Symbols	10
2.3	Basic Safety Information	10
3.	General Equipment Description	11
3.1	COMBIVAC CM 51	11
3.2	THERMOVAC (Pirani) Method of Measurement	11
3.3	PENNINGVAC (cold cathode) Method of Measurement	11
3.4	Connectable Gauge Heads	11
4.	Technical Data	12
4.1	General Data	12
4.1.1	Mechanical Data	12
4.1.2	Standard Parameters (factory defaults)	13
4.1.2.1	Sensor-dependent Parameters	13
4.1.2.2	General Parameters	13
4.1.3	Environment	13
4.1.4	Standards	14
4.2	Mains Connection	14
4.3	Measurement Channels	14
4.3.1	TM Measurement Channels	14
4.3.2	PM Measurement Channel	14
4.3.3	Measurement	14
4.4	Switching Functions / Relay Outputs	15
4.4.1	Switching Function Relay	15
4.4.2	Ready Signal Relay	15

4.5	Outputs and Inputs	15
4.5.1	Analog Output	15
4.5.2	External Control	16
4.5.3	Serial Interfaces	16
4.5.3.1	RS232	16
4.5.3.2	RS485	16
4.5.4	Profibus-DP	16
5.	Installation	17
5.1	Supplied Equipment	17
5.2	Mechanical Installation	17
5.2.1	Rack Installation	18
5.2.2	Front Panel Installation	18
5.2.3	Benchtop Instrument	19
5.3	Connections	20
5.3.1	Rear Side of the Instrument	20
5.3.2	Mains Connection	20
5.3.3	Earthing	21
5.3.4	THERMOVAC Measurement Channels (TM 1 and TM 2)	21
5.3.5	PENNINGVAC Measurement Channel (PM)	21
5.3.6	Analog Output and External Control (Analog Output / Extern Control)	22
5.3.7	RS232 / RS485 Interface (Interface RS232 / RS485)	23
5.3.8	Profibus-DP Interface (Interface Profibus-DP)	23
5.3.9	Relay Output (Relay Output)	24
6.	Operation	25
6.1	Front Panel	25
6.1.1	Display	25
6.1.2	Control Pushbuttons	26
6.2	Switching on and off	26
6.2.1	Switching on	26
6.2.2	Switching off	26
6.3	Operating Modes	27
6.4	Measurement Mode	27
6.4.1	Selection	27
6.4.2	Description	27
6.4.3	Pushbutton Functions	28
6.4.3.1	Measurement Channel Selection	28
6.4.3.2	Parameter Mode Selection	28
6.4.3.3	Switching the PENNINGVAC on	29
6.4.3.4	Switching the PENNINGVAC off	29
6.4.4	THERMOVAC Alignment	30
6.5	Parameter Mode	31
6.5.1	Selection	31
6.5.2	Parameter Groups	31
6.5.3	Operating Concept	32
7.	Parameters	33
7.1	Switching Function Parameters (PArA SP)	33
7.1.1	Basic Terms	33
7.1.2	Configuring the Switching Functions	34
7.1.3	Adjustment Range	34

7.2	Sensor Parameters (PArA SEn)	35
7.2.1	Filament Material THERMOVAC (FIL)	35
7.2.2	Type of Gas Correction THERMOVAC (GAS™)	35
7.2.3	Type of Gas Correction PENNINGVAC (GAS™)	36
7.2.4	Sensor Switch-on Type (S-on)	36
7.2.5	Sensor Switch-on Value (t-on)	36
7.2.6	Sensor Switch-off Type (S-oFF)	37
7.2.7	Sensor Switch-off Value (t-off)	37
7.3	General Parameters (PArA GEn)	37
7.3.1	Unit of Measurement (unit)	38
7.3.2	Analog Output (AnALoG)	38
7.3.3	Display Format (diGit)	38
7.3.4	Display Brightness (bri)	38
7.3.5	Profibus (Pb)	39
7.3.6	Baud Rate (bAud)	39
7.3.7	Interface (rS)	39
8.	Computer Interface	40
8.1	Basics	40
8.1.1	Connection	40
8.1.2	Nomenclature	40
8.2	Communication	41
8.2.1	Protocol	41
8.2.2	General String Structure	41
8.3	Command Set (Mnemonics)	42
8.3.1	Command Overview	42
8.3.2	RPV (Read Pressure Value)	43
8.3.3	RVN (Read Version Number)	43
8.3.4	RSS (Read Set Point Status)	44
8.3.5	SHV (Set HV on/off)	44
8.3.6	SKL (Set Key Lock on/off)	44
8.3.7	SAC (Save Actual Configuration)	45
8.3.8	RSA (Read Serial Adress)	45
8.3.9	SSA (Set Serial Adress)	45
8.3.10	RGP (Read General Parameter)	45
8.3.11	SGP (Set General Parameter)	46
8.3.12	RGC (Read Gas Correction)	47
8.3.13	SGC (Set Gas Correction)	47
8.3.14	RSC (Read Sensor Control)	47
8.3.15	SSC (Set Sensor Control)	48
8.3.16	RSP (Read Set Point)	48
8.3.17	SSP (Set Set Point)	49
9.	Maintenance and Service	50
9.1	Maintenance	50
9.1.1	General Maintenance Information	50
9.2	Troubleshooting	50
9.2.1	Fault Indication	50
9.2.2	Error Messages	50
9.2.3	Help the Case of Faults	51
9.2.4	Fuse Replacement	51
9.2.5	Repair	51

10.	Storing and Waste Disposal	52
10.1	Packaging	52
10.2	Shelving	52
10.3	Waste Disposal	52
Annex 1 - EU Declaration of Conformity		54
Annex 2 - Declaration of Contamination		55

0.1 Table of Figures

Figure 1 – Nameplate (Example)	8
Figure 2 – COMBIVAC CM 51 dimensions (in mm)	12
Figure 3 – Rack installation	18
Figure 4 – Front panel cutout dimensions (in mm)	18
Figure 5 – Preparing the top side of the instrument for utilisation as a benchtop unit	19
Figure 6 – Preparing the bottom side of the	19
Figure 7 – Rear panel of the instrument	20
Figure 8 – Connection plug for analog output and external control (SUB-D, 15-way)	22
Figure 9 – Interface connection socket (SUB-D, 9-way)	23
Figure 10 – Connection socket for Profibus DP interface (SUB-D, 9-way)	23
Figure 11 – Connection plug for relay output (SUB-D, 25-way)	24
Figure 12 – Front panel	25
Figure 13 – Operating the pushbutton CHANNEL	28
Figure 14 – Operating the pushbutton PARA	28
Figure 15 – Operating the pushbutton UP	29
Figure 16 – Operating the pushbutton DOWN	29
Figure 17 – Full-scale alignment for the THERMOVAC gauge head	30
Figure 18 – Zero alignment for the THERMOVAC gauge head	30
Figure 19 – Behaviour of a switching function in response to pressure changes	34

0.2 Table of Tables

Table 1 – Part Numbers	8
Table 2 – Connectable gauge heads	11
Table 3 – Switching parameters, factory defaults	13
Table 4 – Sensor parameters, factory defaults	13
Table 5 – General parameters, factory defaults	13
Table 6 – Supplied equipment	17
Table 7 – Display components	25
Table 8 – Display in the measurement mode	27
Table 9 – Parameter groups and corresponding parameters	31
Table 10 – Available sensor parameters	35
Table 11 – Values for the parameter FIL	35
Table 12 – Values for the parameter unit	38
Table 13 – Values for the parameter AnALoG	38
Table 14 – Values for the parameter diGit	38
Table 15 – Values for the parameter bri	38
Table 16 – Values for the parameter Pb	39
Table 17 – Values for the parameter bAud	39
Table 18 – Values for the parameter rS	39
Table 19 – Terms Computer Interface	40
Table 20 – Control Characters Computer Interface	40
Table 21 – Mnemonics for read commands	42
Table 22 – Mnemonics for write commands	42
Table 23 – Mnemonics for read and write commands	42
Table 24 – Error messages	50

1. Description

1.1 Validity

1.1.1 Part Number

This document applies to the following products:

Part Number	Product	Version	Serial Number
230110	COMBIVAC CM 51 Three-channel measuring instrument for passive vacuum sensors	1.0 et seq.	1000 et seq.
230111	COMBIVAC CM 51 Three-channel measuring instrument for passive vacuum sensors with Profibus DP	1.0 et seq.	1000 et seq.

Table 1 – Part Numbers

1.1.2 Nameplate

A nameplate is located on the bottom side of the instrument. When communicating with Leybold Vacuum GmbH, stating the information on the nameplate is necessary. For this reason please enter the following information:



Figure 1 – Nameplate (Example)

1.2 Conforming Utilisation

The COMBIVAC CM 51 is a universal vacuum gauge which owing to the combination of two principles of measurement - Pirani (Thermovac) and Penning (cold cathode) - permits measurements and checks within the entire vacuum pressure range between $1 \cdot 10^{-9}$ mbar and atmospheric pressure.

One PENNINGVAC sensor and at most two THERMOVAC sensors can be connected.

The built-in RS232/RS485 as well as Profibus-DP interfaces permit computer-controlled operation as well as the exchange of the measurement data between the COMBIVAC CM 51 and a computer.

Operate all connected sensors in agreement with the information given in the corresponding Operating Instructions.



NOTICE:

Based on the technical data please check first whether your measuring instrument is suited to your kind of application.

1.3 Responsibility and Warranty

The Leybold Vacuum GmbH will not assume any responsibility or warranty in case the operator or third persons

- do not observe the information given in this document.
- do not use the product as intended.
- modify the product in any way (conversions, repair work etc).
- operate the product with accessories not listed in the corresponding product documentation.

Subject to technical alterations without prior notice. The figures are not binding.

1.4 Shipping Damage

- Examine the shipping package as to any external damage.
- In case any damage is determined, file a damage report to the forwarding agent and the insurer.
- Retain the packaging material since damages can only be claimed when returning the instrument in the original packaging of the manufacturer.
- Examine the delivery to ensure that it is complete.
- Examine the instrument as to any visually apparent damage.



DANGER: Damaged product.

Commissioning or operating a damaged product is dangerous to life.

2. Safety

2.1 General Information

The COMBIVAC CM 51 is delivered ready for operation. Even so, we recommend that you carefully read these Operating Instructions so as to ensure optimum operating conditions right from the start.

This manual contains important information for understanding, installing, commissioning, operating and troubleshooting the COMBIVAC CM 51.

2.2 Key to the Symbols

Important instructions relating to technical safety and safe operation are emphasised by symbols.



DANGER or WARNING:

Information designed to prevent any kind of injury to persons.



DANGER:

Information designed to prevent injury to persons and damage to equipment in connection with electricity.



NOTICE:

General information pointing to further information, respectively reference sections.

2.3 Basic Safety Information

- During all work like installation, maintenance and repair activities, comply with the pertinent safety regulations.



DANGER: Mains Voltage

Coming into contact with components at mains voltage level within the instrument can be dangerous to life when inserting objects or allowing liquids to enter the instrument.



WARNING: Improper usage.

Improper usage can damage the instrument. Use the instrument only in agreement with the specifications issued by the manufacturer.



WARNING: Wrong Connection and Operating Data.

Wrong connection and operating data can damage the instrument. Comply with all specified connection and operating data.

3. General Equipment Description

3.1 COMBIVAC CM 51

This combination instrument offers three measurement channels, two THERMOVAC and one PENNINGVAC. Thus measurements and checking of vacuum pressures over 12 full decades from $1 \cdot 10^{-9}$ to atmospheric pressure is possible. Six switching thresholds permit the integration of the COMBIVAC CM 51 within complex vacuum control facilities. The two THERMOVAC channels are immediately active upon powering up. The PENNINGVAC channel may be switched on and off by one of the two THERMOVAC channels or externally or manually. The operating status of the switching thresholds and the measurement systems is displayed and signalled correspondingly through the outputs.

3.2 THERMOVAC (Pirani) Method of Measurement

This method of measurement covering the range of $5 \cdot 10^{-4}$ to $1 \cdot 10^3$ mbar utilises the heat conductance of the gas for the purpose of measuring its pressure. In order to attain a response time which is as short as possible, all THERMOVAC instruments rely exclusively the principle of the controlled Pirani where the measurement filament is part of a Wheatstone Bridge. When the temperature of the filament changes due to pressure changes, then the bridge is unbalanced. The quickly responding control circuitry adapts the heating power for the filament so that the filament temperature again reaches its nominal level thereby balancing the measurement bridge again. The displayed pressure is dependent on the type of gas. By default the display of the instruments has been calibrated for nitrogen, respectively air.

3.3 PENNINGVAC (cold cathode) Method of Measurement

For the purpose of measuring the pressure, a high tension is applied to the sensor thereby igniting a gas discharge. The thus produced ion current is output by way of a signal which is proportional to the pressure. This sensor arrangement allows assured and reliable measurement operation of the cold cathode in the range from $1 \cdot 10^{-9}$ mbar to $1 \cdot 10^{-2}$ mbar. Two each versions with KF and CF flange are available.

3.4 Connectable Gauge Heads

The following gauge heads can be operated by the COMBIVAC CM 51:

Gauge heads	Type
THERMOVAC	TR 211, TR 212, TR 216
PENNINGVAC	PR 25, PR 26, PR 27, PR 28

Table 2 – Connectable gauge heads

4. Technical Data

4.1 General Data

4.1.1 Mechanical Data

Dimensions:	Breite: 106.4 mm (1/4 19") Höhe: 128.4 mm (3 HE) Tiefe: 174.5 mm
Wight:	≤ 1.4 kg
Installation depth:	≤ 230 mm approx. (including connected plugs)
Usage:	Rack installation Front panel installation Benchtop instrument

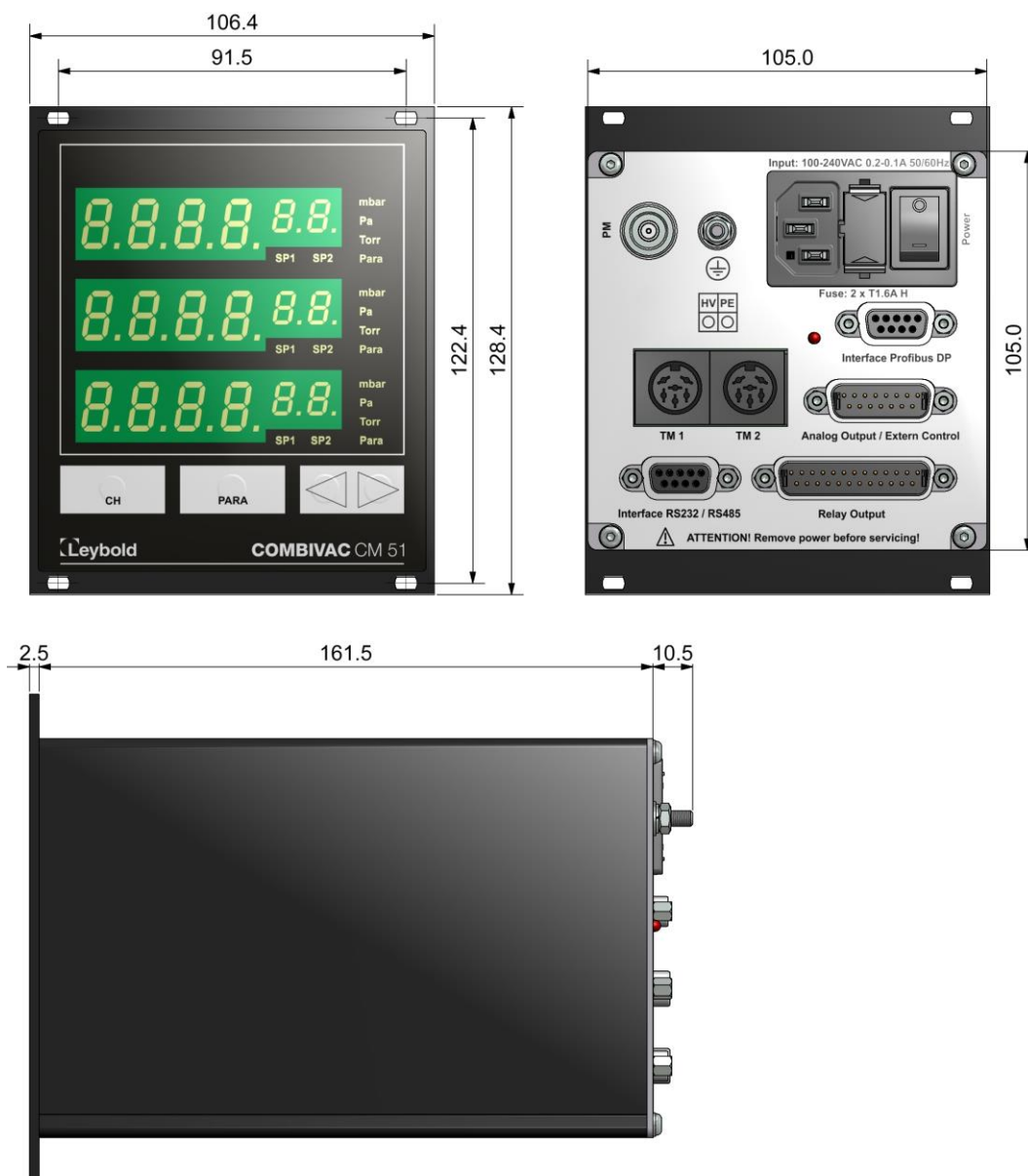

Figure 2 – COMBIVAC CM 51 dimensions (in mm)

4.1.2 Standard Parameters (factory defaults)

4.1.2.1 Sensor-dependent Parameters

Parameter	Parameter description	THERMOVAC setting	PENNINGVAC setting
<i>SP1Lo</i>	Switching threshold 1 – lower threshold	5.0 ⁻³	1.0 ⁻⁸
<i>SP1Hi</i>	Switching threshold 1 – upper threshold	5.5 ⁻³	1.1 ⁻⁸
<i>SP2Lo</i>	Switching threshold 2 – lower threshold	5.0 ⁻³	1.0 ⁻⁸
<i>SP2Hi</i>	Switching threshold 2 – upper threshold	5.5 ⁻³	1.1 ⁻⁸

Table 3 – Switching parameters, factory defaults

Parameter	Parameter description	THERMOVAC setting	PENNINGVAC setting
<i>FIL</i>	THERMOVAC filament material	<i>tU</i> (tungsten)	-
<i>GRS^{t_U}</i>	THERMOVAC gas type correction characteristic	<i>n2</i> (nitrogen)	-
<i>GRS^{P_U}</i>	PENNINGVAC gas type correction factor	-	1.00
<i>S-on</i>	Switch-on type for sensor	-	<i>CH2</i>
<i>S-off</i>	Switch-off type for sensor	-	<i>CH2</i>

Table 4 – Sensor parameters, factory defaults

4.1.2.2 General Parameters

Parameter	Parameter description	Setting
<i>unit</i>	Displayed unit of measurement	<i>bAr</i>
<i>AnALoB</i>	Analog output	2 (CM 51)
<i>digits</i>	Number of displayed digits	2
<i>br_i</i>	Display brightness	<i>Hi</i>
<i>Adr Pb</i>	Profibus address	7
<i>bAud</i>	Baud rate	19.2
<i>rS</i>	Serial interface	232

Table 5 – General parameters, factory defaults

4.1.3 Environment

Temperature:	Storage: -20 – +60 °C
	Operating: +5 – +50 °C (sea level)
	+5 – +30 °C (2000 m above sea level)
Relative atmospheric humidity:	80 % max. (up to 30 °C)
	decreasing to 50 % max. (over 40 °C)
Use:	indoors (altitude 2000 m max. above sea level)
Ingress protection type:	IP40

4.1.4 Standards

- Conformity with respect to Low Voltage Directive 2014/35/EU
- Conformity with respect to EMC Directive 2014/30/EU
- Conformity with respect to RoHS Directive 2011/65/EU

International/national standards as well as specifications:

- DIN EN 61010-1 (2011)
(Safety requirements for electrical equipment for measurement, control and laboratory use).
- DIN EN 61326-1 (2013)
(Electrical equipment for measurement, control and laboratory use – EMC requirements. Industrial interference immunity; electromagnetic emissions household sector Class B).

4.2 Mains Connection

Voltage:	100 – 240 VAC
Frequency:	50/60 Hz
Fuses:	2 x T1.6A H
Power consumption :	< 10 W
Current consumption:	0.2 – 0.1 A approx.
Overvoltage category:	II
Protection category:	1
Connection:	Cold-device plug IEC 320 C14

4.3 Measurement Channels

Number:	Two THERMOVAC measurement channels One PENNINGVAC measurement channels
Connection:	6-way DIN socket for THERMOVAC 1-way HV socket (shielded) for PENNINGVAC

4.3.1 TM Measurement Channels

Measurement range:	$5 \cdot 10^{-4} - 1000$ mbar
Measurement inaccuracy:	± 20 % of measured value ($10^{-3} - 10^{-2}$ mbar) ± 15 % of measured value ($10^{-2} - 10^2$ mbar)
Cable length:	up to 100 m
Cable length alignment:	automatic

4.3.2 PM Measurement Channel

Measurement range:	$1 \cdot 10^{-9} - 1 \cdot 10^{-2}$ mbar
Measurement inaccuracy:	± 30 % of measured value ($10^{-8} - 10^{-4}$ mbar)
Cable length:	up to 100 m for the pressure range $1 \cdot 10^{-8} - 1 \cdot 10^{-2}$ mbar

4.3.3 Measurement

Display rate:	4 s^{-1}
Unit of measurement:	mbar, Pa, Torr

4.4 Switching Functions / Relay Outputs

4.4.1 Switching Function Relay

Number:	6
Assignment:	2 per channel
Response time:	< 50 ms
Adjustment range:	PENNINGVAC $1 \cdot 10^{-8} - 1 \cdot 10^{-2}$ mbar THERMOVAC $5 \cdot 10^{-3} - 5 \cdot 10^2$ mbar
Hysteresis:	adjustable > 10 % of measured value
Contact type:	changeover contact, floating
Load (resistive):	switched current: 1 A max. switched voltage: max. 30 VAC/30 VDC
Service life:	mechanical: $5 \cdot 10^6$ switching cycles Electrical: 10^5 switching cycles at maximum load
Connection:	SUB-D, 25-way, plug

4.4.2 Ready Signal Relay

Number :	3
Assignment:	1 per channel
Response time:	< 50 ms
Contact type:	normally open contact, floating
Load (resistive):	switched current: 1 A max. switched voltage: max. 30 VAC/30 VDC
Service life:	mechanical: $5 \cdot 10^6$ switching cycles Electrical: 10^5 switching cycles at maximum load
Connection:	SUB-D, 25-way, plug

4.5 Outputs and Inputs

4.5.1 Analog Output

Number:	1 per measurement channel
Voltage range:	0 – 10 VDC (limit values 0 – 10.5 VDC)
Output voltage for fault:	10.2 – 10.5 VDC
Deviation of display value:	± 0.2 %
Internal resistance:	100 Ohm
Characteristic:	logarithmic

Measurement Channel	<i>AnALoB 1</i> (CM31)	<i>AnALoB 2</i> (CM 51)
PENNINGVAC	1.43 VDC/Dekade ($0 \text{ V} \triangleq 1 \cdot 10^{-9} \text{ mbar}$) $p = 10^{-9} \text{ mbar} \cdot 10^{(U[V]/1.43V)}$ $p = 10^{-7} \text{ Pa} \cdot 10^{(U[V]/1.43V)}$ $p = 0.75 \cdot 10^{-9} \text{ Torr} \cdot 10^{(U[V]/1.43V)}$	1.333 VDC/Dekade ($0.667 \text{ V} \triangleq 1 \cdot 10^{-9} \text{ mbar}$) $p = 10^{-9} \text{ mbar} \cdot 10^{((U[V]-0.677V)/1.333V)}$ $p = 10^{-7} \text{ Pa} \cdot 10^{((U[V]-0.677V)/1.333V)}$ $p = 0.75 \cdot 10^{-9} \text{ Torr} \cdot 10^{((U[V]-0.677V)/1.333V)}$
THERMOVAC	1.67 VDC/Dekade ($0 \text{ V} \triangleq 1 \cdot 10^{-3} \text{ mbar}$) $p = 10^{-3} \text{ mbar} \cdot 10^{(U[V]/1.67V)}$ $p = 10^{-1} \text{ Pa} \cdot 10^{(U[V]/1.67V)}$ $p = 0.75 \cdot 10^{-3} \text{ Torr} \cdot 10^{(U[V]/1.67V)}$	1.286 VDC/Dekade ($1.9 \text{ V} \triangleq 5 \cdot 10^{-4} \text{ mbar}$) $p = 5 \cdot 10^{-4} \text{ mbar} \cdot 10^{((U[V]-1.9V)/1.286V)}$ $p = 5 \cdot 10^{-2} \text{ Pa} \cdot 10^{((U[V]-1.9V)/1.286V)}$ $p = 3.75 \cdot 10^{-4} \text{ Torr} \cdot 10^{((U[V]-1.9V)/1.286V)}$

Response time:	100 ms approx.
Resolution:	10 Bit
Connection:	SUB-D, 15-way, plug (jointly used together with the connection for external control)

4.5.2 External Control

PLC compatible logic level:	(Low) < 7 VDC; 0 A (High) > 13 VDC; 7 mA (at 24 VDC)
Contact via relay:	24 VDC approx., is provided by the instrument via a self-resetting fuse (100 mA)
Connection:	SUB-D, 15-way, plug (jointly used with the analog output connection)

4.5.3 Serial Interfaces

4.5.3.1 RS232

Standard:	RS232
Parameters:	8 data bits, 1 stop bit, no parity, no protocol
Signals:	RXD and TXD
Baud rate:	9600, 19200, 38400 baud
Connection:	SUB-D, 9-way, socket (jointly used with RS485)

4.5.3.2 RS485

Standard:	RS485 (half-duplex)
Parameters:	8 data bits, 1 stop bit, no parity, no protocol
Signals:	A and B
Baud rate:	9600, 19200, 38400 baud
Connection:	SUB-D, 9-way, socket (jointly used with RS232)

4.5.4 Profibus-DP

Standard:	Profibus-DP
Connection:	SUB-D, 9-way, socket

5. Installation

5.1 Supplied Equipment

Designation	Quantity
COMBIVAC CM 51	1
Mains cord with shockproof plug (EU)	1
Mains cord with shockproof plug (US)	1
Operating Instructions (each GER and ENG)	1
Spare fuses	2
Neck collar screws	4
Plastic sleeves	4
Edge protection	2
Adhesive feet	2

Table 6 – Supplied equipment

5.2 Mechanical Installation

The COMBIVAC CM 51 gauge can be used as follows:

- Rack installation
- Front panel installation
- Benchtopy instrument



WARNING: Powering down

Install the instrument or place it so that you are in a position to operate the mains power switch at any time or ensure that the instrument can be deenergised at any time.

5.2.1 Rack Installation

The COMBIVAC CM 51 has been designed for installation within a sub-rack (19", 3 U) in accordance with DIN EN 60297 (IEC 60297) (🔗📖 Figure 3, page 18). For this purpose the supplied equipment includes four neck collar screws and four plastic sleeves.

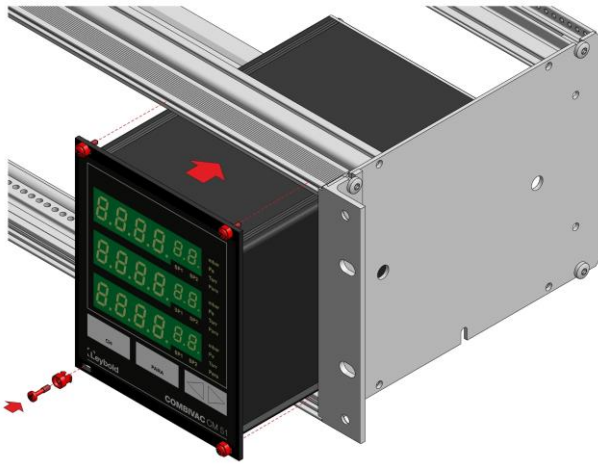

Figure 3 – Rack installation

- Attach the sub-rack within the rack.
- Push the COMBIVAC CM 51 into the sub-rack.
- Affix the instrument to the sub-rack with the neck collar screws and the plastic sleeves included in the delivery.

5.2.2 Front Panel Installation

For panel mounting of the instrument, the following cutout (🔗📖 Figure 4, Page 18) is required:

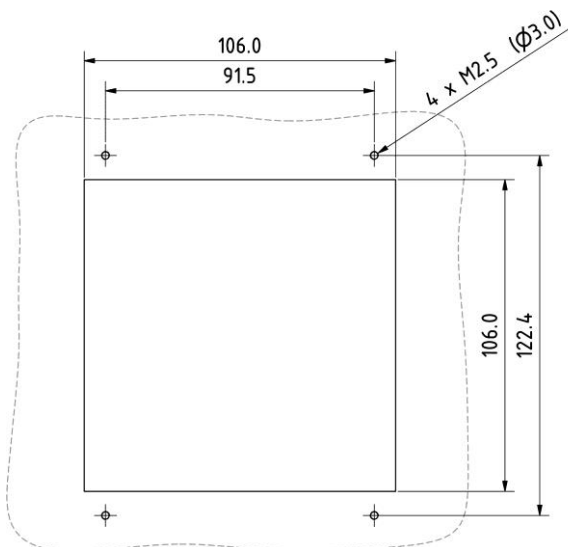

Figure 4 – Front panel cutout dimensions (in mm)

- Guide the COMBIVAC CM 51 into the cut-out.
- Affix the instrument with the neck collar screws and the plastic sleeves included in the delivery.

5.2.3 Benchtop Instrument

When intending to use the COMBIVAC CM 51 as a benchtop instrument, then proceed as follows:

- Push one of the two edge protection rubber pieces included in the delivery over the top edge of the front panel (🔗📖 Figure 5, page 19)
- Place the COMBIVAC CM 51 on its back (🔗📖 Figure 6, page 19)
- Push the second edge protection rubber piece included in the delivery onto the bottom edge of the front panel



WARNING: Risk of suffering injury.

When using the COMBIVAC CM 51 as a benchtop instrument fit the two edge protection rubber pieces onto the top and bottom edge of the front panel so as to avoid injury by sharp edges.

- Stick the two rubber feet included in the delivery onto the bottom of the housing.



Figure 5 – Preparing the top side of the instrument for utilisation as a benchtop unit

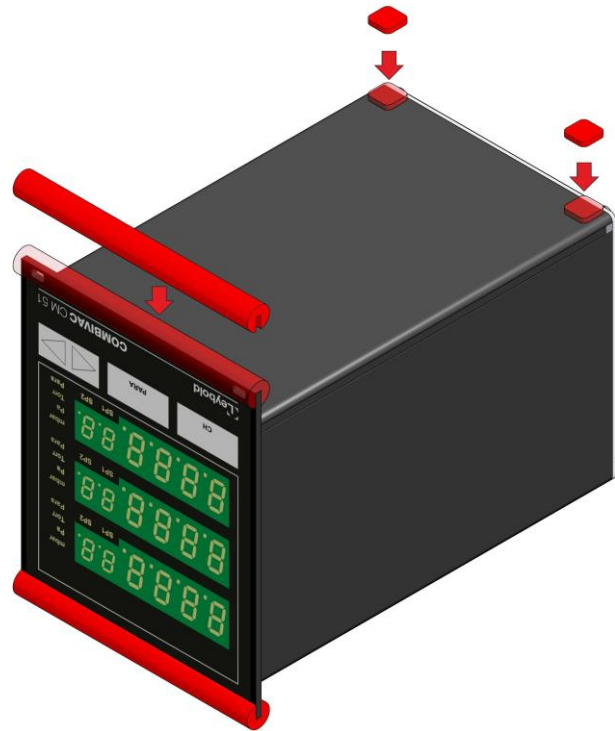

Figure 6 – Preparing the bottom side of the instrument for utilisation as a benchtop unit

- Turn the COMBIVAC CM 51 over again and move it to the desired place.

5.3 Connections

5.3.1 Rear Side of the Instrument

The Figure 7, page 20 shows the rear panel of the COMBIVAC CM 51. The way in which the individual connections have been wired is described in the following sections.

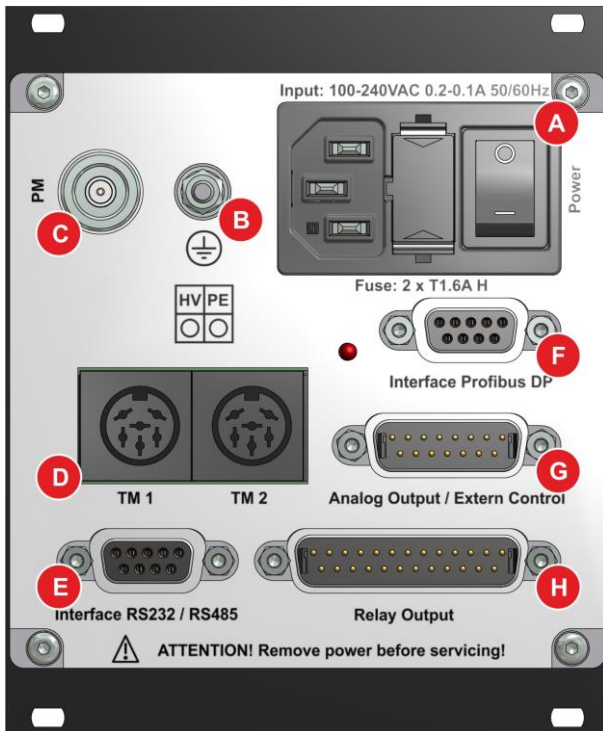

Figure 7 – Rear panel of the instrument

- A Mains connection with mains switch and fuses
- B Ground connection and shield of the TM measurement cables
- C Connection for the PENNINGVAC gauge head (PM)
- D Connections for the THERMOVAC gauge heads (TM1, TM2)
- E Connection for the RS232 or RS485 interface
- F Connection for the Profibus-DP interface with error indicator (red LED)
- G Connection for analog output and external control
- H Connection for relay output

5.3.2 Mains Connection

The mains connection on the rear panel (📖 Figure 7, A, page 20) is intended only for a mains cord which on the instrument side is provided with a inlet connector for non-heating apparatus.



NOTICE: Mains cord

Included in the delivery of the instrument is a mains cord. If the plug on the mains power side is not compatible with your mains power outlets, you will need a mains cord which meets the following specifications:

- Three-wire cable with protective earthing.
- Conductor cross-section: 3 x 0.75 mm² or greater.
- Cable length 2.5 m maximum.



DANGER: Mains voltage

Appliances, which have not been professionally connected to Earth, can be life-threatening in the event of a malfunction. For this reason use three-wire mains cords, respectively extension cords with protective earthing only. Insert the mains plug into a mains power socket, which provides an Earth contact.

- Insert the plug of the mains cord into the mains socket provided on the instrument.
- Insert the mains plug of the mains cord into the mains outlet.

5.3.3 Earthing

With the aid of the earthing screw (🔗📖 Figure 7, B, page 20) the COMBIVAC CM 51 can be connected to the protective ground of the vacuum chamber.



NOTICE: Earthing

Connect the Earth connection on the vacuum chamber by means of a protective earth conductor to the earthing screw on the instrument

5.3.4 THERMOVAC Measurement Channels (TM 1 and TM 2)

The connections TM 1 and TM 2 (🔗📖 Figure 7, D, page 20) serve the purpose of connecting two THERMOVAC gauge heads (🔗📖 Chapter 3.4 Connectable Gauge Heads, page 11). For both measurement channels one each 6-way DIN socket is provided.



CAUTION: Impermissible Sensors.

Gauge heads which have not been designed to be operated in connection with the COMBIVAC CM 51 or which do not comply with current EMC guidelines can impair operation of the instrument or even damage it. Always operate the COMBIVAC CM 51 with approved gauge heads 🔗📖 Chapter 3.4 Connectable Gauge Heads, page 11.

Connecting:

- TM 1: connect the gauge head using the corresponding connecting cable to connection TM1 on the rear of the COMBIVAC CM 51.
- TM 2: connect the gauge head using the corresponding connecting cable to connection TM2 on the rear of the COMBIVAC CM 51.



WARNING:

For utilisation of the connections TM1 and TM2 a special cable is required. The ground connection (🔗📖 Figure 7, B, page 20) of the special cable must under all circumstances be connected to the ground connection on the rear of the instrument.

5.3.5 PENNINGVAC Measurement Channel (PM)

The connection PM (🔗📖 Figure 7, C, page 20) serves the purpose of connecting a PENNINGVAC gauge head (🔗📖 Chapter 3.4 Connectable Gauge Heads, page 11).



DANGER: High tension

The PENNINGVAC gauge head is powered by a high tension (ignition voltage 3.3 kV; operating voltage 1.7 kV / Ri = 6.6 MOhm).



CAUTION: Impermissible Sensors.

Gauge heads which have not been designed to be operated in connection with the COMBIVAC CM 51 or which do not comply with current EMC guidelines can impair operation of the instrument or even damage it. Always operate the COMBIVAC CM 51 with approved gauge heads 🔗📖 Chapter 3.4 Connectable Gauge Heads, page 11.

Connecting:

- Connect the PENNINGVAC gauge head through the corresponding connecting cable to the connection PM on the rear of the COMBIVAC CM 51.
- Lock the plug using the knurled nut provided at the plug.



WARNING:

For utilising the connection PM, a special cable from the company Leybold Vacuum GmbH must be used.

5.3.6 Analog Output and External Control (Analog Output / Extern Control)

The Connection Analog Output / Extern Control (📖 Figure 7, G, page 20 and Figure 8, page 22) provides the connections of the analog outputs for the signals of the individual measurement channels as well as the inputs for externally controlling the PENNINGVAC gauge.

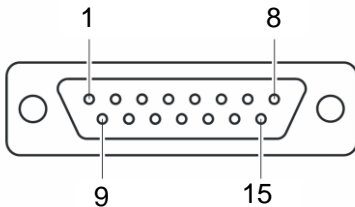
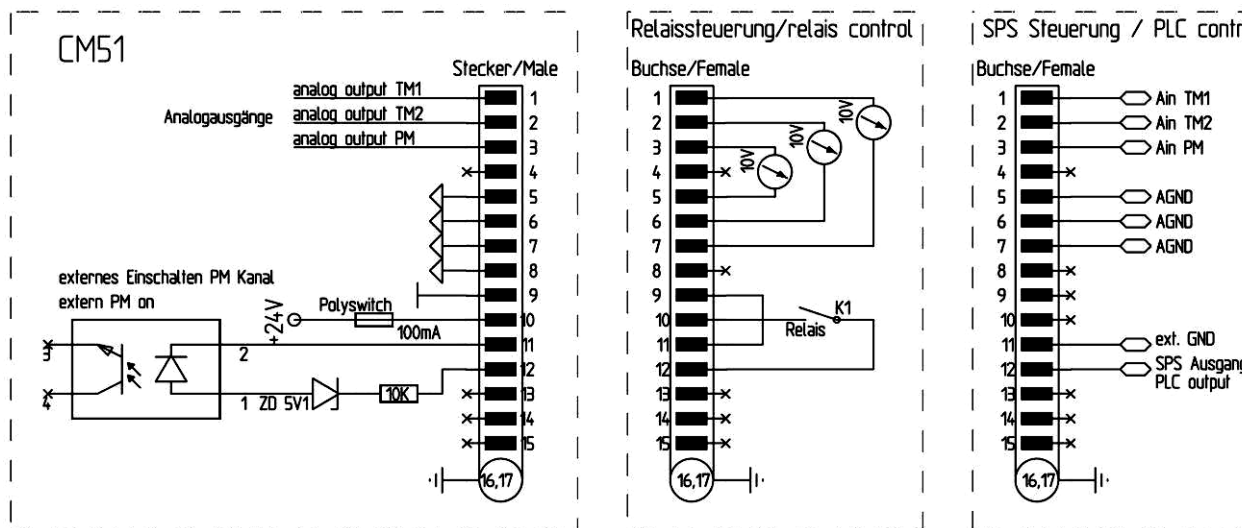

Figure 8 – Connection plug for analog output and external control (SUB-D, 15-way)



Connecting:

- Connect the peripheral components using a shielded connecting cable to the connection Analog Output/Extern Control on the rear of the COMBIVAC CM 51.

5.3.7 RS232 / RS485 Interface (Interface RS232 / RS485)

The connection Interface RS232 / RS485 (🔗📖 Figure 7, E, page 20 and Figure 9, page 23) permits operation of the instrument via a computer or a terminal.

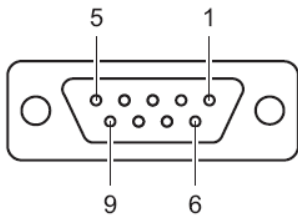

Figure 9 – Interface connection socket (SUB-D, 9-way)

1	B (RS485)	6	Link with 4
2	TxD (RS232)	7	Link with 8
3	RxD (RS232)	8	Link with 7
4	Link with 6	9	A (RS485)
5	Ground		

Connecting:

- Connect the serial interface of the computer using a shielded cable to the connection RS232/RS485 on the rear of the COMBIVAC CM 51.



WARNING:

When using the serial interface RS232 use a serial extension cable with a 9-way plug and a 9-way socket. The wires in the cable must not be crossed. Utilisation of the RS485 requires a special cable.

5.3.8 Profibus-DP Interface (Interface Profibus-DP)

The connection Interface Profibus DP (🔗📖 Figure 7, F, page 20 and Figure 9, page 23) provides full integration of the instrument within a Profibus-DP bus system.

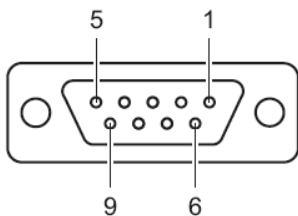

Figure 10 – Connection socket for Profibus DP interface (SUB-D, 9-way)

1	not used	6	+ 5 VDC
2	not used	7	not used
3	RxD / TxD-P	8	DGND
4	CNTR	9	DGND
5	DGND		

Connecting:

- Connect the bus system using a corresponding bus cable to the connection Profibus DP interface on the rear of the COMBIVAC CM 51.



WARNING:

For utilisation of the Profibus DP interface a standard compliant bus cable is required.

5.3.9 Relay Output (Relay Output)

Through the connection Relay Output (🔑📖 Figure 7, H, page 20 and Figure 11, page 24) you can utilise the floating relay contacts for switching purposes and ready signals.

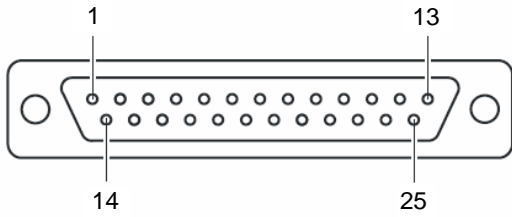
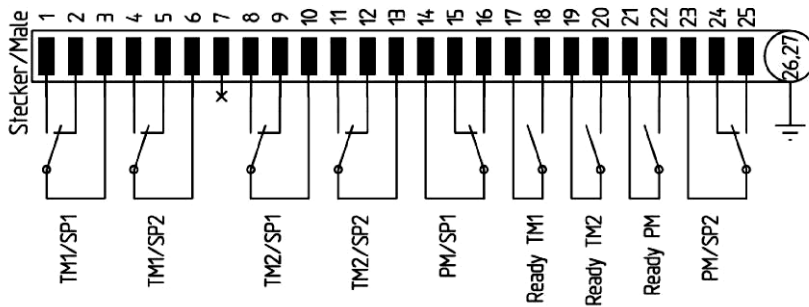

Figure 11 – Connection plug for relay output (SUB-D, 25-way)



DANGER: Dangerous voltage

Voltages exceeding 60 VDC or 30 VAC are dangerous when touched. You may only switch at the connector marked Relay Output voltages of 30 VDC or 30 VAC with a maximum current of 1 A. The voltage must comply with the requirements of a safety extra-low voltage (SELV-E in accordance with EN 61010).

6. Operation

6.1 Front Panel

Figure 12, page 25 depicts the front panel of the COMBIVAC CM 51.



Figure 12 – Front panel

- A Display of channel 1 with two corresponding switching thresholds
- B Display of channel 2 with two corresponding switching thresholds
- C Display of channel 3 with two corresponding switching thresholds
- D Status indication operating pushbuttons

6.1.1 Display

Display	Description
0.0.0.0. ^{BB}	Measured value or status message
SP1, SP2	Switching function status When the symbol is lit, the pressure is then below the lower threshold When the symbol is not lit, then the pressure is above the upper threshold
mbar, Pa, Torr	Pressure unit (applies to all channels)
Para	Channel selection, configuration mode for channel

Table 7 – Display components

6.1.2 Control Pushbuttons

CH

With the pushbutton CH you can select a measurement channel. This is necessary, for example, when wanting to switch the PENNINGVAC gauge head on or off, or when wanting to change the sensor parameters. The number of the selected measurement channel is displayed flashing for 10 seconds.

PARA

Through the pushbutton PARA you can invoke the parameter mode for switching threshold, sensor and general parameters. The indicator Para for the selected measurement channel comes on. You can set up different parameters.

Arrow pushbuttons (<I DOWN / I> UP)

The arrow pushbuttons are needed so as to be able to enter data in the parameter mode or switch the PENNINGVAC gauge head on or off ([🔗](#) Chapter 6.4.3.3 Switching the PENNINGVAC on and 6.4.3.4 Switching the PENNINGVAC off, page 29). By operating the pushbuttons, a default value can be reduced or increased. The corresponding pushbuttons are designated in the following as DOWN (<I) and UP (I>).

6.2 Switching on and off

6.2.1 Switching on

- Switch the instrument on through its mains switch.

After switching on, the COMBIVAC CM 51 runs the following:

- Self test
- Display test
- Display of the software version used
- Re-establishing the parameters set up last
- Identification of the connected measuring equipment
- Activation of the measurement mode

6.2.2 Switching off

- Switch the instrument off through its mains switch.



WARNING: Waiting time

Wait for at least 5 seconds before switching the instrument on again.

6.3 Operating Modes

The COMBIVAC CM 51 may be operated in one of the following operating modes:

Measurement Mode

The measurement mode is the standard operating mode. Here the measured values or status messages are displayed.  Chapter 6.4 Measurement Mode, page 27

Parameter Mode

In the parameter mode you have access to different parameters. You can simply view the parameters all change them with the aid of the arrow keys. In this way you can configure the COMBIVAC CM 51.  Chapter 31 Parameter Mode, Page 31

6.4 Measurement Mode

6.4.1 Selection

After switching on the COMBIVAC CM 51 it will automatically run the measurement mode. If running the parameter mode and when not operating a key for 10 seconds the instrument will then automatically revert back to the measurement mode.

6.4.2 Description

In the measurement mode the measured values of the gauge heads are displayed. When the pressure is outside the permissible range, then a status message is displayed. Measurement channels to which no gauge head has been connected will indicate noSEn. This status message is erased after 30 seconds and 4 dots are displayed.

Display	Description
1000 ⁿⁿ	Above the permissible range (overrange)
0.000 ^{-B}	Within the permissible range
c0.00 ^{-B}	Below the permissible range (underrange)
5 oFF	Gauge head has been switched off
HU on	PENNINGVAC is on

Table 8 – Display in the measurement mode

6.4.3 Pushbutton Functions

6.4.3.1 Measurement Channel Selection

- Press the pushbutton CH.
 - The instrument selects the next measurement channel. The display of Para for the selected measurement channel will flash for 10 seconds.

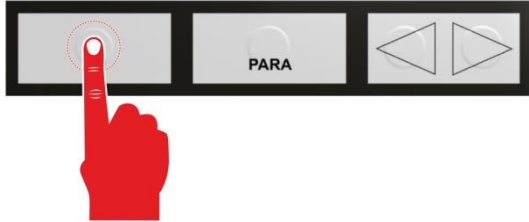

Figure 13 – Operating the pushbutton CHANNEL

6.4.3.2 Parameter Mode Selection

- Press the pushbutton PARA and keep it depressed for approximately 2 seconds.
 - The instrument will change to the parameter mode (see Chapter 31 Parameter Mode, Page 31).
 - When not operating any pushbutton within 10 seconds, the instrument will then automatically return to the measurement mode.

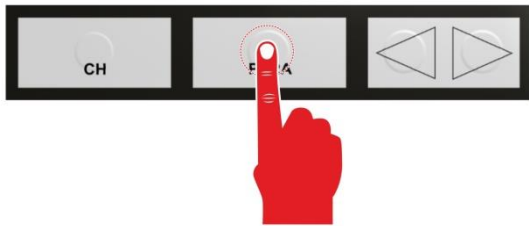

Figure 14 – Operating the pushbutton PARA

6.4.3.3 Switching the PENNINGVAC on

The PENNINGVAC gauge head can be switched on manually. For this, sensor control must be set to Hand (👉📖 Chapter 7.2.4 Sensor Switch-on Type (S-on), page 36).

- Press the pushbutton CH so as to select measurement channel 3.
- Keep the key marked UP pressed for approximately two seconds.
 - The PENNINGVAC gauge head at measurement channel 3 is switched on. Either the measured value or a status message will be displayed (👉📖 Table 8, Page 27).



Figure 15 – Operating the pushbutton UP

6.4.3.4 Switching the PENNINGVAC off

The PENNINGVAC gauge head can be switched off manually. For this, sensor control must be set to Hand (👉📖 Chapter 7.2.6 Sensor Switch-off Type (S-off), page 37).

- Press the pushbutton CH so as to select measurement channel 3.
- Keep the key marked DOWN pressed for approximately two seconds.
 - The PENNINGVAC gauge head at measurement channel 3 is switched off. The display will indicate the status OFF.

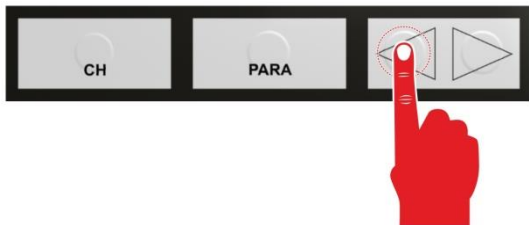

Figure 16 – Operating the pushbutton DOWN

6.4.4 THERMOVAC Alignment

Ageing and contamination of the sensor filament will impair the accuracy of the pressure readout. For this it is recommended to align the THERMOVAC gauge head as required. For this, the gauge head must be orientated in the same way in which it is subsequently operated. The alignment process is run as follows:

- Vent and the vacuum apparatus and adjust the 100% potentiometer at the THERMOVAC gauge head so that the following readout is obtained:



Figure 17 – Full-scale alignment for the THERMOVAC gauge head

- In order to ensure a stable but also precise alignment of the 100% point, the alignment potentiometer (100%) should be turned further by 90° in the clockwise direction after the indication of 1000 mbar has been displayed. Here the overrange indicator should just come on.
- Evacuate the vacuum apparatus to a pressure $< 5 \cdot 10^{-4}$ mbar and adjust the “0” potentiometer at the THERMOVAC gauge head so that the following reading is attained:



Figure 18 – Zero alignment for the THERMOVAC gauge head

- Vent the vacuum apparatus and check the 100% setting once more. Correct a possible deviation with the potentiometer.
- If a correction of the 100% setting was necessary, then repeat the Zero adjustment.

6.5 Parameter Mode

6.5.1 Selection

By operating the PARA pushbutton for approximately 2 seconds the instrument changes from the measurement mode to the parameter mode. The Para indicator comes on for the channel selected in each case. When the instrument is running in the parameter mode and if no pushbutton is operated for 10 seconds, then the instrument will automatically return back to the measurement mode. The Para indicator for the channel which was selected in each case is turned off.

6.5.2 Parameter Groups

In the parameter mode you have access to different parameters. You may view these parameters or change these with the aid of the arrow pushbuttons. In this way you can configure the instrument. Table 9, Page 31 depicts all available parameters.

Parameter Groups	Parameter
PARA SP	SP I-L SP I-H SP2-L SP2-H
PARA SEn	F iL GAS ^t GAS ^P S-on S-off
PARA GEn	un it AnALoG d iG it br i Adr Pb bAud rS

Table 9 – Parameter groups and corresponding parameters

The available parameters have been divided into the following parameter sets:

Switching function parameters (PARA SP)

These parameters affect only the sensor of the selected measurement channel. Per measurement channel, two switching functions are available.

 Chapter 7.1 Switching Function Parameters (PARA SP), page 33.

Sensor parameters (PARA SE_n)

These parameters affect only the selected measurement channel. Per measurement channel, two switching functions are available.

 Chapter 7.2 Sensor Parameters (PARA SE_n), page 34.

General parameters (PARA GE_n)

With the aid of these parameters you can generally configure the instrument. The parameters apply to all measurement channels.

 Chapter 7.3 General Parameters (PARA GE_n), page 37.

6.5.3 Operating Concept

From the measurement mode, you can select and change a certain parameter as follows:

- Press the pushbutton CH, so as to select the desired measurement channel (only necessary when wanting to change a sensor parameter)
 - The Para status indicator flashes for the selected channel.
- Press the PARA pushbutton for about 2 seconds.
 - You have now invoked the parameter menu.
- Use the arrow pushbuttons to select the desired parameter group.
 - The name of the parameter group is displayed.
- Press the PARA pushbutton to select the desired parameter.
 - The name and the value of the parameter are displayed.
- Use the arrow pushbuttons and to change the value of the parameter.
 - The value of the parameter is changed.
- Repeat the last 2 steps so as to change further parameters of the same parameter group.

After having accessed the last parameter of a parameter group, the instrument will switch back to the measurement mode. Changes to the parameters become effective immediately and are automatically saved to the EEPROM.

When the instrument is running in the parameter mode and if for a period of 10 seconds no changes are made to the parameters, then the instrument will automatically return to the measurement mode. Any parameter changes made up to this point are automatically saved to the EEPROM.



NOTICE:

When the instrument is running in the parameter mode, and when not entering a change for more than 10 seconds, then the instrument will automatically return back to the measurement mode. Any changes, which have been entered and confirmed up to this point of time, are automatically saved in the EEPROM.

7. Parameters

7.1 Switching Function Parameters (PArA SP)

In this parameter group you can configure the switching functions. The COMBIVAC CM 51 provides the following switching function parameters:

- SP1-Lo
- SP1-Hi

- SP2-Lo
- SP2-Hi

7.1.1 Basic Terms

Switching functions

The COMBIVAC CM 51 contains in all 6 switching function relays, i.e. the switching functions 1 and 2 are available for each measurement channel. These switch depending on the measured pressure. The contacts of the relays are floating and may be used for switching purposes through the connection marked Relay Output ([🔗📖 Chapter 5.3.9 Relay Output \(Relay Output\), Page 23](#)).

Threshold values

The switching behaviour of individual relays is defined in each case through two parameters: the lower threshold and the upper threshold value of the switching function.

Lower threshold value SPx-Lo

The lower threshold value governs switching on of the assigned switching function. When the pressure drops below the lower threshold value, then the relay is energised. The common contact of the relay is then connected to the normally open contact.

Upper threshold value SPx-Hi

The upper threshold value governs switching off of the assigned switching function. When the pressure exceeds the upper switching threshold, then the relay is de-energised. The common contact of the relay is then connected to the normally closed contact.

Hysteresis

In the pressure range between the two thresholds, the current relay status is maintained. Within this range the relay will not switch over and the relay status depends on the history ([🔗📖 Figure 19, page 34](#)).

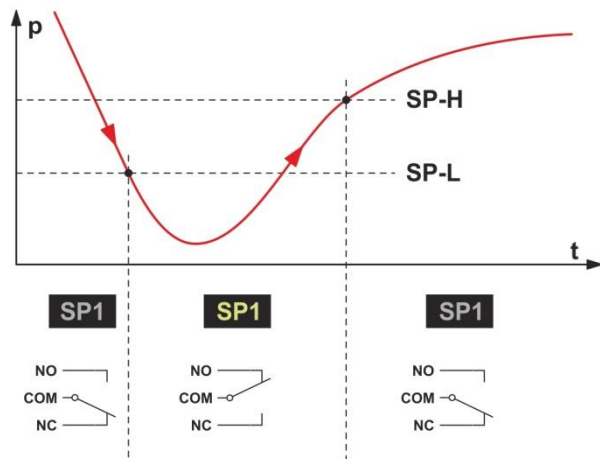

Figure 19 – Behaviour of a switching function in response to pressure changes

p Pressure
t Time
NO Normally open contact
COM Common contact
NC Normally closed contact

The range between the lower and the upper threshold value produces a certain amount of hysteresis between switching on and switching off of the relay. The hysteresis prevents rapid switching on and off of the switching function when the pressure is close to a switching threshold.

7.1.2 Configuring the Switching Functions

- Select the desired measurement channel by operating the pushbutton CH several times.
- Keep the pushbutton PARA depressed for approximately 2 seconds.
 - The instrument is now running the parameter mode in the parameter group SP.
- Press the pushbutton PARA to select the desired parameter.
 - The name and the value of the parameter are displayed.
- Use the arrow pushbuttons so as to change the threshold value.
 - The value of the parameter is changed.
- Repeat the steps to change further parameters of the parameter group.

7.1.3 Adjustment Range

The upper and the lower threshold value can be changed depending on the type of sensor in the range between $5 \cdot 10^2$ and $1 \cdot 10^{-8}$ mbar.

Hysteresis amounts to at least 10% of the lower threshold value.



CAUTION:

Select the threshold values for the PENNINGVAC in the range from $1 \cdot 10^{-8}$ to $1 \cdot 10^{-2}$ mbar and for the THERMOVAC in the range from $5 \cdot 10^{-3}$ to $5 \cdot 10^2$ mbar.

7.2 Sensor Parameters (PARA SEn)

For each measurement channel there exists a separate set of sensor parameters. Depending on which transmitter is connected to the respective measurement channel, different parameters are available (📖 Table 10, page 35).

Gauge heads	FIL	GAS TM	GAS ^{Pi}	S-on	S-off
PENNINGVAC			✓	✓	✓
THERMOVAC	✓	✓			

Table 10 – Available sensor parameters

- Select the desired measurement channel by operating the pushbutton CH several times.
- Keep the pushbutton PARA depressed for approximately 2 seconds
 - The instrument is now running the parameter mode.
- Use the arrow keys to access the parameter group SEn.
- Press the pushbutton PARA to select the desired parameter.
 - The name and the value of the parameter are displayed.
- Use the arrow keys to change the parameter setting.
- Repeat the steps to change further parameters of the parameter group.

7.2.1 Filament Material THERMOVAC (FIL)

Filament material of the connected THERMOVAC gauge head.

Display	Description
W	Tungsten TR 211, TR 212
Pt	Platinum TR 216

Table 11 – Values for the parameter FIL

7.2.2 Type of Gas Correction THERMOVAC (GASTM)

The THERMOVAC gauge heads are normally calibrated for measurements in nitrogen or air. With the aid of the parameter GASTM you can set up the measurement channel to the other type of gas in each case. You may select the characteristic for a gauge head between nitrogen (N₂) and argon (Ar).

For this proceed as follows:

- Select the parameter GASTM.
- Press the pushbutton PARA.
 - The setup characteristic is displayed.
- Use the arrow pushbuttons so as to change the characteristic.
 - The value of the parameter is changed.

7.2.3 Type of Gas Correction PENNINGVAC (GAS^{PM})

The PENNINGVAC gauge heads are normally calibrated for measurements in nitrogen or air. With the aid of the parameter GAS^{PM} you can set up the measurement channel to other types of gas.

For this proceed as follows:

- Select the parameter GAS^{PM}.
- Press the pushbutton PARA.
 - The setup characteristic is displayed.
- Use the arrow pushbuttons so as to change the characteristic.
 - The value of the parameter is changed.



You can set up the correction factor for a gauge head in the range of 0.2 – 1.0 – 8.0. The setting of 1.0 supplies the uncorrected measured value.

7.2.4 Sensor Switch-on Type (S-on)

This parameter defines how the PENNINGVAC gauge head is switched on.

You can set the switch-on time to the following values:

HAnd

Manual. The gauge head can be switched on by pressing the pushbutton UP (  Chapter 6.4.3.3 Switching the PENNINGVAC on, page 29).

ECt

Externally through optocoupler (PLC compatible high-level > 13 VDC; 7 mA at 24 VDC).

Hot

Warm start. The sensor is switched on automatically upon switching on the instrument. After a power failure the measurement is started automatically.



CH 1

Through measurement channel TM1. With the aid of the next parameter t-on you can define a switch-on value. When the pressure in the measurement channel TM1 drops below the switch-on value, the sensor is switched on.

CH 2

Through measurement channel TM2. With the aid of the next parameter t-on you can define a switch-on value. When the pressure in the measurement channel TM2 drops below the switch-on value, the sensor is switched on.

7.2.5 Sensor Switch-on Value (t-on)

This parameter will only appear when the sensor switch-on time has been set to CH 1 or CH 2 (  Chapter 7.2.4 Sensor Switch-on Type (S-on), page 36).



Through the parameter t-on you can define a switch-on value. When the pressure in the respective measurement channel drops below the switch-on value, the gauge head is switched on.

7.2.6 Sensor Switch-off Type (S-oFF)

This parameter defines how the PENNINGVAC gauge head is switched off.

You can set up the switch-off type to the following values:

HAnd

Manual. The gauge head can be switched off by pressing the pushbutton DOWN (  Chapter 6.4.3.4 Switching the PENNINGVAC off, Page 29).

ECt

Externally through an optocoupler (PLC compatible low-level < 7 VDC; 0 A at 24 VDC).

SELF

Self-monitoring. With the aid of the next parameter t-off you can define a switch-off value. When the pressure at the gauge head exceeds the switch-off value then the gauge head is switched off.



CH 1

Through measurement channel TM1. With the aid of the next parameter t-off you can define a switch-off value. When the pressure in the measurement channel TM1 exceeds the switch-off value then the sensor is switched off.

CH 2

Through measurement channel TM2. With the aid of the next parameter t-off you can define a switch-off value. When the pressure in the measurement channel TM2 exceeds the switch-off value then the sensor is switched off.

7.2.7 Sensor Switch-off Value (t-off)

This parameter will only appear when the sensor switch-off type has been set to CH1 or CH 2 (  Chapter 7.2.6 Sensor-Ausschaltart (S-oFF), Page 37).

Through the parameter t-off you can define a switch-off value. When the pressure in the respective measurement channel exceeds the switch-off value, the gauge head is switched off.

7.3 General Parameters (PArA GEn)

With the aid of these parameters you can generally configure the instrument. The parameters apply to all measurement channels.



- Keep the pushbutton PARA depressed for approximately 2 seconds.
 - The instrument is now in the parameter mode.
- Use the arrow pushbuttons so as to access the parameter group GEn.
- Press the pushbutton PARA to select the desired parameter.
 - The name and the value of the parameter are displayed.
- Use the arrow pushbuttons so as to change the parameter setting.
- Repeat the steps so as to change further parameters of the parameter group.

7.3.1 Unit of Measurement (unit)

Unit of measurement for pressure values. This unit of measurement affects the displayed pressure values, threshold values etc.

Display	Description
bAr	Unit of measurement mbar
torr	Unit of measurement Torr
PA	Unit of measurement Pascal

Table 12 – Values for the parameter unit

The unit of measurement is indicated on the display (  Figure 12, Page 25, Position E).

7.3.2 Analog Output (AnALoG)

Analog output for the gauge heads.





Display	Description
1	CM31 mode (  Chapter 4.5.1 Analog Output, page 15)
2	CM 51 mode (  Chapter 4.5.1 Analog Output, page 15)

Table 13 – Values for the parameter AnALoG

7.3.3 Display Format (diGit)

Number of digits on the display.

Display	Description
2	2 digits, for example 2.5 ⁻¹
3	3 digits, for example 2.47 ⁻¹

Table 14 – Values for the parameter diGit

7.3.4 Display Brightness (bri)

Display brightness.

Display	Description
H i	High brightness
L o	Low brightness

Table 15 – Values for the parameter bri

7.3.5 Profibus (Pb)

Selection of the Profibus address.

Display	Description
1 – 126	Adress 1 – 126

Table 16 – Values for the parameter Pb

	CAUTION: The changed Profibus bus address will only become effective after having restarted the instrument.
---	---

7.3.6 Baud Rate (bAud)

Baud rate of the interface

Display	Description
9.6	Baud rate 9600 baud
19.2	Baud rate 19200 baud
38.4	Baud rate 38400 baud

Table 17 – Values for the parameter bAud

	CAUTION: The changed baud rate will only become effective after having restarted the instrument.
---	--

7.3.7 Interface (rS)

Selection of the interface.

Display	Description
232	Interface RS232
485	Interface RS485

Table 18 – Values for the parameter rS

8. Computer Interface

8.1 Basics

8.1.1 Connection

The COMBIVAC CM 51 can communicate with the computer through a serial interface. The interfaces RS232 or RS485 are selectively available. The selection is made through the parameter group PArA GEn in the parameter mode (🔑📖 Chapter 7.3 General Parameters (PArA GEn), page 37).

The respective connecting socket and the necessary connecting cable are described in the Chapter 5.3.7, page 23.

8.1.2 Nomenclature

The following terms and symbolical spellings are used in order to describe the computer interface:

Terms	Description
Send	Data transfer from the host to the instrument
receive	Data transfer from the instrument to the host
Host	Terminal (Computer)
ASCII	American Standard Code for Information Interchange

Table 19 – Terms Computer Interface

Square Brackets [...]

Square brackets mark parameters.

Sharp Brackets <...>

Abbreviations in sharp brackets mark control characters. The complete term including the sharp brackets is replaced by a numerical value.

Terms	Value	Description
<,>	0x2C	Separator
<CR>	0x0D	Terminator

Table 20 – Control Characters Computer Interface

8.2 Communication

8.2.1 Protocol

The following log is used for communication:

- 8 data bits
- no parity bit
- 1 stop bit

The baud rate is selectable.

- 9600
- 19200
- 38400

No hardware handshake is used. The messages are transferred by way of ASCII strings. A comma (0x2C) in the string is taken as a separating character. Space characters (0x20) or tabs (0x09) may be contained in the string. As to the communication, the computer is always the master. The input buffer of the computer must have a capacity of at least 50 bytes.

8.2.2 General String Structure

Input of **Address** is necessary for RS485 only

Output of **Address** for RS485 only

Write command

S: **Address Command** <,> [**Parameter**] <CR>

E: **OK**

Reading command

S: **Address Command** <CR>

E: **Address** <,> <TAB> [**Parameter**] <CR>

Error code

E: ? <TAB> X

E: ? <TAB> P <,> <TAB> z

E: ? <TAB> C <,> <TAB> x

E: ? <TAB> S <,> <TAB> x

E: ? <TAB> K

Incorrect command

Incorrect parameter,
Parameter number of the
transmitted command

Channel x on device not available

No sensor on Channel x
connected

No divider in the command
available

8.3 Command Set (Mnemonics)

8.3.1 Command Overview

Read Commands	Description
RPV	Read Pressure Value. Read the pressure value for a measurement channel.
RVN	Read Version Number Read the instrument software version number.
RSS	Read Setpoint Status Read the status of the switching thresholds for a channel.

Table 21 – Mnemonics for read commands

Write Commands	Description
SHV	Set HV on/off Switch the high voltage on or off for a channel.
SKL	Set Key Lock on/off Switch the keylock on or off.
SAC	Save Actual Configuration Save the current configuration for switching threshold, sensor and general parameters.

Table 22 – Mnemonics for write commands

Read and Write Commands	Description
RSA	Read Serial Address Read address for RS485.
SSA	Set Serial Address Set address for RS485.
RGP	Read General Parameter Read instrument settings.
SGP	Set General Parameter Set instrument settings.
RGC	Read Gas Correction Read type of gas correction factor for a measurement channel.
SGC	Set Gas Correction Set type of gas correction factor for a measurement channel.
RSC	Read Sensor Control Read type of sensor control for a measurement channel.
SSC	Set Sensor Control Set type of sensor control for a measurement channel.
RSP	Read Setpoint Read switching thresholds for a channel.
SSP	Set Setpoint Set switching thresholds for a channel.

Table 23 – Mnemonics for read and write commands

	<p>CAUTION: All changes to values are only permanently saved to the EEPROM after having issued the write command SAC. For this reason after having set all values, save the current configuration through the SAC write command before restarting the instrument.</p>
---	--

8.3.2 RPV (Read Pressure Value)

Reading a pressure value for a measurement channel.

S: **RPV[a]<CR>**

E: **b[,][TAB]x.xxxxE±xx**

Parameter	Description
a	Channel number 1 = Channel 1 (TM1) 2 = Channel 2 (TM2) 3 = Channel 3 (PM)
b	Status 0 = Measured value OK 1 = Measured value < measurement range 2 = Measured value > measurement range 3 = Measured values << measurement range (Err Lo) 4 = Measured values >> measurement range (Err Hi) 5 = Sensor off (S oFF) 6 = HV on (HU on) 7 = Sensor error (Err S) 9 = No sensor(no Sen) 10 = No switch-on or switch-off threshold (notriG) 12 = Pirani error (Err Pi)
x.xxxxE±xx	Pressure value of the selected channel in the current unit of measurement

8.3.3 RVN (Read Version Number)

Reading the version number of the instrument software.

S: **RVN<CR>**

E: **x.xx<CR>**

Parameter	Description
x.xx	Versions number

8.3.4 RSS (Read Set Point Status)

Reading the status of the switching thresholds for a channel.

S: **RSS[a]<CR>**

E: **b[,][TAB]c<CR>**

Parameter	Description
a	Channel number 1 = Channel 1 (TM1) 2 = Channel 2 (TM2) 3 = Channel 3 (PM)
b	Status SP1 0 = low 1 = high
c	Status SP2 0 = low 1 = high

8.3.5 SHV (Set HV on/off)

Setting HV on/off for PENNINGVAC, if switch-on and switch-off type have been set to manual.

S: **SHV[a, b]<CR>**

E: **OK<CR>**

Parameter	Description
a	Channel number 3 = Channel 3 (PM)
b	HV on/off 0 = off 1 = on

8.3.6 SKL (Set Key Lock on/off)

Switching the keylock on or off.

S: **SKL[a]<CR>**

E: **OK<CR>**

Parameter	Description
a	Key lock 0 = off 1 = on

8.3.7 SAC (Save Actual Configuration)

Saving current configuration for switching threshold, sensor and general parameters.

S: SAC<CR>

E: OK<CR>

8.3.8 RSA (Read Serial Adress)

Read adress for RS485.

S: RSA<CR>

E: a<CR>

Parameter	Description
a	Adress 1 – 126 (01 – 7E) (output in the HEX format)

8.3.9 SSA (Set Serial Adress)

Setting adress for RS485.

S: SSA[a]<CR>

E: OK<CR>

Parameter	Description
a	Adress 1 – 126 (01 – 7E) (entry must be in the HEX format)

8.3.10 RGP (Read General Parameter)

Reading instrument settings.

S: RGP<CR>

E: a[,] [TAB] b[,] [TAB] c[,] [TAB] d[,] [TAB] e[,] [TAB] f[,] [TAB] g <CR>

Parameter	Description
a	Unit 0 = mbar 1 = Pa 2 = Torr
b	Analog output 0 = CM 31 mode 1 = CM 51 mode
c	Number of displayed digits 0 = 2 1 = 3

Parameter (continued)	Description
d	Brightness 0 = hoch 1 = gering
e	Profibus 1 – 126
f	Baud rate 0 = 9600 1 = 19200 2 = 38400
g	Serial interface 0 = RS232 1 = RS485

8.3.11 SGP (Set General Parameter)

Setting instrument settings.

S: **SGP[a, b, c, d, e, f, g]<CR>**

E: **OK <CR>**

Parameter	Description
a	Unit 0 = mbar 1 = Pa 2 = Torr X = Parameter remains unchanged
b	Analog output 0 = CM 31 mode 1 = CM 51 mode X = Parameter remains unchanged
c	Number of displayed digits 0 = 2 1 = 3 X = Parameter remains unchanged
d	Brightness 0 = hoch 1 = gering X = Parameter remains unchanged
e	Profibus 1..126
f	Baud rate 0 = 9600 1 = 19200 2 = 38400 X = Parameter remains unchanged
g	Serial interface 0 = RS232 1 = RS485 X = Parameter remains unchanged



CAUTION:

Changes to the parameters baud rate and Profibus address become only effective after having restarted the instrument. Before restarting, save the current configuration using the SAC write command.

8.3.12 RGC (Read Gas Correction)

Reading the type of gas correction factor for a measurement channel.

S: **RGC[a]<CR>**

E: **b<CR>**

Parameter	Description
a	Channel number 3 = Channel 3 (PM)
b	Gas type correction factor channel Format X.XX with a range of values 0.20 – 8.00

8.3.13 SGC (Set Gas Correction)

Setting the type of gas correction factor for a measurement channel.

S: **SGC[a, b]<CR>**

E: **OK<CR>**

Parameter	Description
a	Channel number 3 = Channel 3 (PM)
b	Gas type correction factor channel Format X.XX with a range of values 0.20 – 8.00

8.3.14 RSC (Read Sensor Control)

Reading the type of sensor control for PENNINGVAC.

S: **RSC[a]<CR>**

E: **b[,][TAB]c[,][TAB]x.xxxxE±xx[,][TAB]x.xxxxE±xx<CR>**

Parameter	Description
a	Channel number 3 = Channel 3 (PM)
b	Sensor switch-on type channel 0 = Manual 1 = External 2 = n.a. 3 = Through channel 1 4 = Through channel 2
c	Sensor switch-off type channel 0 = Manual 1 = External 2 = Self-monitoring 3 = Through channel 1 4 = Through channel 2
x.xxxxE±xx	Switch-on value in the current unit of measurement
x.xxxxE±xx	Switch-off value in the current unit of measurement

8.3.15 SSC (Set Sensor Control)

Setting the type of sensor control for PENNINGVAC.

S: **SSC[a, b, c, x.xxxxE±xx, x.xxxxE±xx]<CR>**

E: **OK<CR>**

Parameter	Description
a	Channel number 3 = Channel 3 (PM)
b	Sensor switch-on type channel 0 = Manual 1 = External 2 = n.a. 3 = Through channel 1 (TM1) 4 = Through channel 2 (TM2)
c	Sensor switch-off type channel 0 = Manual 1 = External 2 = Self-monitoring 3 = Through channel 1 (TM1) 4 = Through channel 2 (TM2)
x.xxxxE±xx	Switch-on value in the current unit of measurement
x.xxxxE±xx	Switch-off value in the current unit of measurement

8.3.16 RSP (Read Set Point)

Reading the switching thresholds for a channel.

S: **RSP[a]<CR>**

E: **b[,][TAB]c[,][TAB]d[,][TAB]e<CR>**

Parameter	Description
a	Channel number 1 = Channel 1 (TM1) 2 = Channel 2 (TM2) 3 = Channel 3 (PM)
b	SP1 low (pressure value of the switching threshold in the current unit of measurement in the form of x.xxxxE±xx)
c	SP1 high (pressure value of the switching threshold in the current unit of measurement in the form of x.xxxxE±xx)
d	SP2 low (pressure value of the switching threshold in the current unit of measurement in the form of x.xxxxE±xx)
e	SP2 high (pressure value of the switching threshold in the current unit of measurement in the form of x.xxxxE±xx)

8.3.17 SSP (Set Set Point)

Setting the switching thresholds for a channel.

S: **SSP[a, b, c, d, e]<CR>**

E: **OK<CR>**

Parameter	Description
a	Channel number 1 = Channel 1 (TM1) 2 = Channel 2 (TM2) 3 = Channel 3 (PM)
b	SP1 low (pressure value of the switching threshold in the current unit of measurement in the form of x.xxxxE±xx)
c	SP1 high (pressure value of the switching threshold in the current unit of measurement in the form of x.xxxxE±xx)
d	SP2 low (pressure value of the switching threshold in the current unit of measurement in the form of x.xxxxE±xx)
e	SP2 high (pressure value of the switching threshold in the current unit of measurement in the form of x.xxxxE±xx)

9. Maintenance and Service

9.1 Maintenance

9.1.1 General Maintenance Information

For external cleaning please use a piece of dry cotton cloth. Do not use any aggressive or abrasive detergents.



DANGER: Mains voltage

The instrument contains inside components at a high voltage. Never introduce any objects into the openings of the instrument. Protect the instrument against moisture. Do not open the instrument.

9.2 Troubleshooting

9.2.1 Fault Indication

A malfunction affecting the COMBIVAC CM 51 is indicated by an error message on the display. (🔗📖 Chapter 9.2.2 Error Messages, page 50)

9.2.2 Error Messages



Error (display)	Fault cause and remedy
<i>Err Lo</i>	Measurement signal from the gauge head significantly below the permissible range.
<i>Err Hi</i>	Measurement signal from the gauge head significantly above the permissible range.
<i>Err 5</i>	Sensor error. Malfunction affecting the connection to the gauge head. The message will only be displayed in the display field for the affected measurement channel. Acknowledge by pressing any key.
<i>no 5En</i>	No gauge head connected to the measurement channel. The status message disappears after 30 seconds.
<i>notr iB</i>	Error affecting the switch-on or switch-off channel. No switch-on or switch-off threshold has been defined for the PENNINGVAC gauge head (malfunction of the THERMOVAC gauge head, for example).
<i>F iL br</i>	Filament broken. Filament of the THERMOVAC vacuum gauge head is defective. The error message persists until the sensor is replaced.

Table 24 – Error messages

9.2.3 Help the Case of Faults

If the malfunction persists even after having replaced the gauge heads, please contact your nearest Leybold GmbH service office.

9.2.4 Fuse Replacement

To replace blown fuses use only the type of fuse T1.6A H specified on the rear of the instrument. The two fuses of the instrument are located in the fuse insert at the mains filter (  Figure 7, page 20), which may be levered out using a small screwdriver.

9.2.5 Repair

Send defective products for repair to your nearest Leybold GmbH service office. The company Leybold Vacuum GmbH will not assume any responsibility or honour a warranty if the operator or third persons have attempted repair work on the COMBIVAC CM 51.

10. Storing and Waste Disposal

10.1 Packaging

Please retain the original packaging. You will need this packaging material when wanting to store the COMBIVAC CM 51 or when returning it to the Leybold Vacuum GmbH.

10.2 Shelving

The COMBIVAC CM 51 must only be stored in dry room. During storage, the following ambient conditions need to be maintained:

- Ambient temperature: -20 – +60 °C
- Humidity of the air: As low as possible.
Preferably in a sealed plastic bag with desiccant.

10.3 Waste Disposal

As to waste disposal, the branch-specific and local waste disposal and environment regulations for equipment containing electronic components apply.

When returning the equipment to the Leybold GmbH, proper and professional separation of the recyclable fraction and its disposal is ensured.

Notes:

EU Declaration of Conformity

(Translation of original Declaration of Conformity)

The manufacturer: Leybold GmbH
Bonner Strasse 498
D-50968 Köln
Germany

herewith declares that the products specified and listed below which we have placed on the market, comply with the applicable EU Council Directives. This declaration becomes invalid if modifications are made to the product without agreement of Leybold GmbH.

Product designation: Vacuum gauge controller
Type designation: COMBIVAC CM51, COMBIVAC CM51PB
Part numbers: 230110, 230111

The products complies to the following European Council Directives:

Low Voltage Directive (2014/35/EU)

Electromagnetic Compatibility (2014/30/EU)

RoHS Directive (2011/65/EU)

The following harmonized standards have been applied:

EN 61010-1:2010	Safety requirements for electrical equipment for measurement, control, and laboratory use — Part 1: General requirements
EN 61326-1:2013	Electrical equipment for measurement, control and laboratory use — EMC requirements — Part 1: General requirements Emissions: Group 1, Class B Immunity: Industrial electromagnetic environment

Documentation officer: Herbert Etges
T: +49(0)221 347 0
F: +49(0)221 347 1250
documentation@leybold.com

Cologne, September 01, 2016

Cologne, September 01, 2016



ppa. Martin Tollner
VP / Head of Product Lines



ppa. Dr. Monika Mattern-Klosson
Head of Quality & Business Process Management

Declaration of Contamination of Compressors, Vacuum Pumps and Components

The repair and / or servicing of compressors, vacuum pumps and components will be carried out only if a correctly completed declaration has been submitted. Non-completion will result in delay. The manufacturer can refuse to accept any equipment without a declaration.

A separate declaration has to be completed for each single component.

This declaration may be completed and signed only by authorized and qualified staff.

Customer/Dep./Institute : _____ Address : _____ _____ Person to contact: _____ Phone : _____ Fax: _____ End user: _____	Reason for return: <input checked="" type="checkbox"/> applicable please mark Repair: <input type="checkbox"/> chargeable <input type="checkbox"/> warranty Exchange: <input type="checkbox"/> chargeable <input type="checkbox"/> warranty <input type="checkbox"/> Exchange already arranged / received Return only: <input type="checkbox"/> rent <input type="checkbox"/> loan <input type="checkbox"/> for credit Calibration: <input type="checkbox"/> DKD <input type="checkbox"/> Factory-calibr. <input type="checkbox"/> Quality test certificate DIN 55350-18-4.2.1
--	--

A. Description of the Leybold product: Material description : _____ Catalog number: _____ Serial number: _____ Type of oil (ForeVacuum-Pumps) : _____	Failure description: _____ Additional parts: _____ Application-Tool: _____ Application- Process: _____
--	---

B. Condition of the equipment	No ¹⁾	Yes	No	Contamination :	No ¹⁾	Yes
1. Has the equipment been used	<input type="checkbox"/>	<input type="checkbox"/>	<input checked="" type="checkbox"/>	toxic	<input type="checkbox"/>	<input type="checkbox"/>
2. Drained (Product/service fluid)	<input checked="" type="checkbox"/>	<input type="checkbox"/>	<input type="checkbox"/>	corrosive	<input type="checkbox"/>	<input type="checkbox"/>
3. All openings sealed airtight	<input checked="" type="checkbox"/>	<input type="checkbox"/>	<input type="checkbox"/>	flammable	<input type="checkbox"/>	<input type="checkbox"/>
4. Purged	<input type="checkbox"/>	<input type="checkbox"/>	<input type="checkbox"/>	explosive ²⁾	<input type="checkbox"/>	<input type="checkbox"/>
If yes, which cleaning agent _____				radioactive ²⁾	<input type="checkbox"/>	<input type="checkbox"/>
and which method of cleaning _____				microbiological ²⁾	<input type="checkbox"/>	<input type="checkbox"/>
¹⁾ If answered with "No", go to D. ←				other harmful substances	<input type="checkbox"/>	<input type="checkbox"/>

C. Description of processed substances (Please fill in absolutely)	
1. What substances have come into contact with the equipment ? Trade name and / or chemical term of service fluids and substances processed, properties of the substances According to safety data sheet (e.g. toxic, inflammable, corrosive, radioactive)	
X	Tradename: _____ Chemical name: _____
a)	_____
b)	_____
c)	_____
d)	_____
2. Are these substances harmful ? No <input type="checkbox"/> Yes <input type="checkbox"/>	
3. Dangerous decomposition products when heated ? No <input type="checkbox"/> Yes <input type="checkbox"/>	
If yes, which ? _____	
²⁾ Components contaminated by microbiological, explosive or radioactive products/substances will not be accepted without written evidence of decontamination.	

D. Legally binding declaration
 I / we hereby declare that the information supplied on this form is accurate and sufficient to judge any contamination level.

Name of authorized person (block letters) : _____ _____ Date	_____ signature of authorized person	firm stamp
--	---	------------

Sales and Service

Germany

Leybold GmbH

Sales, Service, Support Center (3SC)
Bonner Strasse 498
D-50968 Cologne
T: +49-(0)221-347 1234
F: +49-(0)221-347 31234
sales@leybold.com
www.leybold.com

Leybold GmbH

Sales Area North

Branch Office Berlin
Industriestrasse 10b
D-12099 Berlin
T: +49-(0)30-435 609 0
F: +49-(0)30-435 609 10
sales.bn@leybold.com

Leybold GmbH

Sales Office South

Branch Office Munich
Karl-Hammerschmidt-Strasse 34
D-85609 Aschheim-Dornach
T: +49-(0)89-357 33 9-10
F: +49-(0)89-357 33 9-33
sales.mn@leybold.com
service.mn@leybold.com

Leybold Dresden GmbH

Service Competence Center

Zur Wetterwarte 50, Haus 304
D-01109 Dresden
Service:
T: +49-(0)351-88 55 00
F: +49-(0)351-88 55 041
info.dr@leybold.com

Europe

Belgium

Leybold Nederland B.V.

Belgisch bijkantoor

Leuvensesteenweg 542-9A
B-1930 Zaventem
Sales:
T: +32-2-711 00 83
F: +32-2-720 83 38
sales.zv@leybold.com
Service:
T: +32-2-711 00 82
F: +32-2-720 83 38
service.zv@leybold.com

France

Leybold France S.A.S.

Parc du Technopolis, Bâtiment Beta
3, Avenue du Canada
F-91940 Les Ulis cedex
Sales and Service:
T: +33-1-69 82 48 00
F: +33-1-69 07 57 38
info.ctb@leybold.com
sales.ctb@leybold.com

Leybold France S.A.S.

Valence Factory
640, Rue A. Bergès
B.P. 107
F-26501 Bourg-lès-Valence Cedex
T: +33-4-75 82 33 00
F: +33-4-75 82 92 69
marketing.vc@leybold.com

Great Britain

Leybold UK LTD.

Unit 9
Silverglade Business Park
Leatherhead Road
Chessington
Surrey (London)
KT9 2QL
Sales:
T: +44-13-7273 7300
F: +44-13-7273 7301
sales.in@leybold.com
Service:
T: +44-13-7273 7320
F: +44-13-7273 7303
service.in@leybold.com

Italy

Leybold Italia S.r.l.

Via Trasimeno 8
I-20128 Mailand
Sales:
T: +39-02-27 22 31
F: +39-02-27 20 96 41
sales.mi@leybold.com
Service:
T: +39-02-27 22 31
F: +39-02-27 22 32 17
service.mi@leybold.com

Netherlands

Leybold Nederland B.V.

Floridadreef 102
NL-3565 AM Utrecht
Sales and Service:
T: +31-(30) 242 63 30
F: +31-(30) 242 63 31
sales.ut@leybold.com
service.ut@leybold.com

Switzerland

Leybold Schweiz AG, Pfäffikon

Churerstrasse 120
CH-8808 Pfäffikon
Warehouse and shipping address:
Riedthofstrasse 214
CH-8105 Regensdorf
Sales:
T: +41-44-308 40 50
F: +41-44-302 43 73
sales.zh@leybold.com
Service:
T: +41-44-308 40 62
F: +41-44-308 40 60
service.zh@leybold.com

Spain

Leybold Spain, S.A.

C/. Huerva, 7
E-08940 Cornellà de Llobregat
(Barcelona)
Sales:
T: +34-93-666 43 11
F: +34-93-666 43 70
sales.ba@leybold.com
Service:
T: +34-93-666 46 11
F: +34-93-685 43 70
service.ba@leybold.com

Headquarter

Leybold GmbH

Bonner Strasse 498
D-50968 Cologne
T: +49-(0)221-347-0
F: +49-(0)221-347-1250
info@leybold.com

America

USA

Leybold USA Inc.

5700 Mellon Road
USA-Export, PA 15632
T: +1-724-327-5700
F: +1-724-325-3577
info.ex@leybold.com
Sales:
T: +1-724-327-5700
F: +1-724-333-1217
Service:
T: +1-724-327-5700
F: +1-724-325-3577

Brazil

Leybold do Brasil

Rod. Vice-Prefeito Hermenegildo Tonolli,
nº. 4413 - 6B
Distrito Industrial
Jundiaí - SP
CEP 13.213-086
Sales and Service:
T: +55 11 3395 3180
F: +55 11 99467 5934
sales.ju@leybold.com
service.ju@leybold.com

Asia

P. R. China

Leybold (Tianjin)

International Trade Co. Ltd.
Beichen Economic
Development Area (BEDA),
No. 8 Western Shuangchen Road
Tianjin 300400
China
Sales and Service:
T: +86-22-2697 0808
F: +86-22-2697 4061
F: +86-22-2697 2017
sales.tj@leybold.com
service.tj@leybold.com

India

Leybold India Pvt Ltd.

No. 82(P), 4th Phase
K.I.A.D.B. Plot
Bommasandra Industrial Area
Bangalore - 560 099
Indien
Sales and Service:
T: +91-80-2783 9925
F: +91-80-2783 9926
sales.bgl@leybold.com
service.bgl@leybold.com

Japan

Leybold Japan Co., Ltd.

Headquarters
Shin-Yokohama A.K.Bldg., 4th floor
3-23-3, Shin-Yokohama
Kohoku-ku, Yokohama-shi
Kanawaga 222-0033
Japan
Sales:
T: +81-45-471-3330
F: +81-45-471-3323
sales.yh@leybold.com

Leybold Japan Co., Ltd.

Tsukuba Technical Service Center
1959, Kami-yokoba
Tsukuba-shi, Ibaraki-shi 305-0854
Japan
Service:
T: +81-29 839 5480
F: +81-29 839 5485
service.iik@leybold.com

Malaysia

Leybold Malaysia

Leybold Singapore Pte Ltd.

No. 1 Jalan Hi-Tech 2/6
Kulim Hi-Tech Park
Kulim, Kedah Darul
Aman 09000
Malaysia
Sales and Service:
T: +604 4020 222
F: +604 4020 221
sales.ku@leybold.com
service.ku@leybold.com

South Korea

Leybold Korea Ltd.

3F. Jellzone 2 Tower
Jeongja-dong 159-4
Bundang-gu Sungnam-si
Gyeonggi-do
Bundang 463-384, Korea
Sales:
T: +82-31 785 1367
F: +82-31 785 1359
sales.bd@leybold.com
Service:
623-7, Upsung-Dong
Cheonan-Si
Chungcheongnam-Do
Korea 330-290
T: +82-41 589 3035
F: +82-41 588 0166
service.cn@leybold.com

Singapore

Leybold Singapore Pte Ltd.

8 Commonwealth Lane #01-01
Singapore 149555
Singapore
Sales and Service:
T: +65-6303 7030
F: +65-6773 0039
sales.sg@leybold.com
service.sg@leybold.com

Taiwan

Leybold Taiwan Ltd.

No 416-1, Sec. 3
Chunghsin Rd., Chutung
Hsinchu County 310
Taiwan, R.O.C.
Sales and Service:
T: +886-3-500 1688
F: +886-3-583 3999
sales.hc@leybold.com
service.hc@leybold.com



www.leybold.com