

Series 316

Granville-Phillips® Series 316 Convectron®
Vacuum Measurement Controller

GRANVILLE-PHILLIPS®

Instruction Manual

Instruction manual part number 316005
Revision B - December 2012



Series 316

Granville-Phillips® Series 316 Convector® Vacuum Measurement Controller

GRANVILLE-PHILLIPS®

Customer Service/Support

For customer service within the USA, 8 AM to 5 PM
Mountain Time Zone, weekdays excluding holidays:

Granville-Phillips

6450 Dry Creek Parkway
Longmont, CO 80503 USA

Phone: +1-800-776-6543
Phone: +1-303-652-4400
FAX: +1-303-652-2844
Email: co-csr@brooks.com

Brooks Automation, Inc.

15 Elizabeth Drive
Chelmsford, MA 01824 USA

Phone: +1-978-262-2400

For customer service, 24 hours per day, 7 days per week,
every day of the year including holidays within the USA:

Phone +1-800-367-4887

World Wide Web: www.brooks.com

Instruction Manual

© 2012 Brooks Automation, Inc. All rights reserved.

Granville-Phillips® and Convector® are registered trademarks of Brooks Automation, Inc. All other trademarks and registered trademarks are the properties of their respective owners.



Catalog numbers Series 316 Convectron Vacuum Gauge Controller with 3-Line Display

This Instruction Manual is for use with all Granville-Phillips Series 316 Vacuum Measurement Controllers listed below. The “#” symbol represents a variable in the catalog number.

Configured for Convectron Gauge on Channel A

Half-rack mount	316501 - # # # - # #
Left mount for 19-inch rack	316502 - # # # - # #
Center mount for 19-inch rack	316503 - # # # - # #
Bench top configured for Convectron Gauge	316504 - # # # - # #

Configured for Thermocouple Gauge on Channel A

Half-rack mount	316505 - # # # - # #
Left mount for 19-inch rack	316506 - # # # - # #
Center mount for 19-inch rack	316507 - # # # - # #
Bench top configured for Thermocouple Gauge	316508 - # # # - # #

Interface Options (Slot X):

- None
- RS-232
- RS-485
- IEEE 488
- Linear Analog Output

Gauge Options (Slot Y):

- None
- Dual Convectron
- Convectron / Capacitance Manometer
- Dual Thermocouple

Setpoint Options (Slot XZ):

- None
- 2 setpoint relays for Channel A
- 6 setpoint relays, 2 per channel

Display Options (Measurement Units):

- Torr
- Mbar
- PA

Power Cord Options (Slot XZ):

- North America 115 V
- North America 240 V
- Universal Europe 220 V
- United Kingdom 240 V

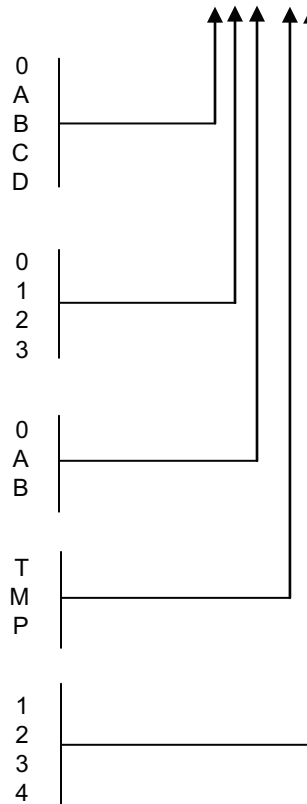

Table of Contents

Safety Instructions	7
Receiving Inspection	8
International Shipment	8
Limited Warranty	8

Chapter 1 - 316 VGC Control Unit

1.1 Introduction/General Description	9
1.1.1 Available Configurations	9
1.2 Installation	10
1.2.1 Line Voltage Selection	10
1.2.2 Module Installation	10
1.2.3 To Install a Module	11
1.3 Mounting Configurations	13
1.4 Cable Connections	13
1.4.1 Instrument Grounding	14
1.5 Operation	14
1.5.1 Summary of Controls and Indicators	14
1.5.2 Units of Measure	14
1.6 Theory of Operation	15
1.6.1 Microcontrollers and Bus Structure	15
1.6.2 Convector Gauge Theory	15
1.6.3 Capacitance Manometer Theory	15
1.7 Calibration	16
1.8 Basic Troubleshooting	16
1.8.1 Guidelines	16
1.8.2 Troubleshooting Guide	17
1.9 Repair Ordering	17
1.10 Specifications (316 Vacuum Gauge Controller)	18
Service Form	19

Chapter 2 - Convector Gauge Module

2.1 Safety Notices	20
2.1.1 Explosive Gases	20
2.1.2 Limitation on Use of Compression Mounts	20
2.1.3 Gauge Tube Mounting Position	20
2.1.4 Overpressure	20
2.1.5 High Indicated Pressure	20
2.1.6 Chemicals	20
2.1.7 Sensor Failure	21
2.1.8 Gauge Tube Contamination	21
2.2 Convector Module, Introduction	21
2.2.1 Units of Pressure Measurement	21
2.3 Convector Gauge Tube Installation	22
2.3.1 Gauge Tube Orientation	23
Compression Mount (Quick Connect)	23
1/8 NPT Mount	23
NW16KF Flange Mount	24
Other Mounting Options	24
2.4 Convector Gauge Operation	24
2.4.1 Reading Pressure	24

Special Considerations For Use Below 10 ⁻³ Torr	24
Use With Gases Other Than N ₂ and Air	24
Indicated vs. True Pressure Curves	25
2.4.2 Analog Output	33
2.5 Convector Gauge Calibration and Maintenance	34
2.5.1 Zero Adjustment (VAC)	34
2.5.2 Atmosphere Adjustment (ATM)	34
2.5.3 Analog Output Full Scale Adjustment	34
2.5.4 Analog Output Offset; Gauges A, B, and C	34
2.5.4 Cleaning the Gauge Tube	35
2.6 Theory of Operation	36
2.7 Convector Gauge Troubleshooting	36
2.7.1 Transducer Test Procedure	36
2.7.2 Convector Troubleshooting Guide	37
2.8 Convector Gauge Specifications	38
Display Resolution	38

Chapter 3 - Thermocouple Gauge Module

3.1 Introduction	39
3.2 Thermocouple Gauge Module Installation	39
3.2.1 Units of Measure	39
3.3 Thermocouple Gauge Tube Installation	40
3.4 Thermocouple Gauge Operation	40
3.4.1 Reading Pressure	40
3.4.2 Analog Output	40
3.5 Thermocouple Gauge Calibration	41
3.5.1 Zero Adjustment (VAC)	41
3.5.2 Atmosphere Adjustment (ATM)	41
3.6 Theory of Operation	42
3.7 Thermocouple Gauge Troubleshooting	43
3.7.1 Troubleshooting Guide	43
3.8 Thermocouple Gauge Specifications	44
Display Resolution	44

Chapter 4 - Capacitance Manometer Module

4.1 Introduction	45
4.2 Installation	45
Units of Measure	45
Display Slow Update Rate Switch	46
Convector Gauge Controls	46
Capacitance Manometer Vacuum Calibration	46
Capacitance Manometer Range Switch	46
4.3 Capacitance Manometer Cable Installation	46
4.4 Operation	47

4.4.1 Reading Pressure	47
4.4.2 Analog Output	47
4.5 Calibration	48
4.5.1 Initial Transducer Calibration	48
To Set The Controller Zero (Initial Controller Setup)	48
To Zero The 316 VGC with the Transducer	48
4.5.2 Convector Controls	49
4.5.3 Capacitance Manometer Analog Output Offset Adjust	49
4.5.4 Capacitance Manometer Analog Output Full-Scale Adjust.....	49
4.5.5 Capacitance Manometer Full-Scale Adjust.....	49
4.6 Theory of Operation	49
4.7 Capacitance Manometer Troubleshooting.....	50
4.8 Specifications	50

Chapter 5 - Process Control Module

5.1 Safety Notices	51
5.1 Introduction.....	51
5.2 Process Control Module Installation.....	51
5.2.1 Process Control System Connections.....	51
5.3 Process Control Operation.....	52
5.3.1 Setpoint Display and Adjustment	52
To Display a Setpoint.....	53
To Modify a Setpoint.....	53
5.3.2 Points to Consider in Using the Process Control Module	53
Relay Polarity Setting.....	54
5.3.3 Manual Override.....	55
5.4 Process Control Theory of Operation.....	55
5.5 Process Control Troubleshooting.....	55
5.6 Process Control Specifications	55

Chapter 6 - RS-232 Module

6.1 Introduction.....	56
6.2 RS-232 Installation	56
6.2.1 Selecting the Byte Format.....	56
6.2.2 Baud Rate	56
6.2.3 Character Framing	56
6.2.4 Talk-Only Mode.....	57
6.2.5 Handshake Line Control Switches	57
6.2.6 Invert RTS Switch	57
6.3 Operation.....	57
6.3.1 Command Syntax	58
6.4 RS-232 Theory of Operation	59
Handshaking	59
6.5 RS-232 Troubleshooting	60
6.5.1 RS-232 Troubleshooting Guide	60
6.6 RS-232 Specifications	61

Chapter 7 - IEEE 488 Module

7.1 Introduction	62
7.2 IEEE 488 Installation	62
7.2.1 Selecting the Interface Bus Address Talk-Only Mode.....	62
SRQ Mode	63
7.3 IEEE 488 Operation	63
7.3.1 Command Syntax	63
7.4 IEEE 488 Troubleshooting	64
7.5 IEEE 488 Troubleshooting Guide.....	65
7.5 IEEE 488 Specifications.....	65

Chapter 8 - RS-485 Module

8.1 Introduction	66
8.2 RS-485 Installation	66
8.2.1 RS-485 Address.....	66
8.2.2 Response Delay for the RS-485 Interface	67
8.2.3 Selecting the Byte Format for RS- 485 Communications.....	67
8.2.4 Character Framing for the RS-485 Computer Interface.....	67
8.2.5 Connecting the RS-485 Computer Interface	67
8.2.6 Preparing for Use.....	69
8.3 RS-485 Command Syntax	70
8.4 RS-485 Troubleshooting	71
8.4.1 Troubleshooting Guide.....	71
8.5 RS-485 Specifications.....	71

Chapter 9 - Linear Analog Output Module

9.1 Introduction	72
9.2 Installation	72
9.2.1 Cable Connections.....	72
Pin Assignments	72
9.3 Operation	72
9.4 Calibration	72
9.4.1 Gauge Output Zero Adjust.....	73
9.4.2 Gauge Output Full Scale Adjust.....	73
9.5 Theory of Operation	74
9.6 Troubleshooting	74
9.7 Specifications	74
Thermocouple Output.....	74

Safety Instructions and General Information

Be sure to read through this instruction manual before installing, using, or servicing this equipment. If you have any questions or doubts about how to use this equipment safely, contact the Brooks Automation, Inc. Customer Service Department listed at the front of this manual.

Danger – Hazardous Voltage

AC line voltage is present within the controller chassis. Disconnect the power cable before removing the cover. Exercise caution when operating the controller with covers off. Servicing should be performed by qualified personnel only.

Danger – Explosive Gases

Do not use Series 316 instruments when there is danger of explosion from ignition of explosive or combustible gases or gas mixtures. The sensor wire of the Series 275 transducers normally operates at only 125 °C, but it is possible that momentary transients or controller malfunction can raise the sensor temperature above the ignition temperature of combustible mixtures. Thermocouple gauge transducers also operate at elevated temperatures, and the same safety considerations apply.

Danger – Implosion or Explosion

Danger of injury to personnel and damage to equipment exists on all vacuum systems that incorporate gas sources or involve processes capable of pressurizing the system above the limits it can safely withstand.

For example, danger of explosion in a vacuum system exists during backfilling from pressurized gas cylinders because many vacuum devices such as ionization gauge tubes, glass windows, glass bell jars, etc, are not designed to be pressurized.

Install suitable devices that will limit the pressure from external gas sources to the level that the vacuum system can safely withstand. In addition, install suitable pressure relief valves or rupture disks that will release pressure at a level considerably below that pressure which the system can safely withstand.

Suppliers of pressure relief valves and pressure relief disks are listed in Thomas Register under "Valves, Relief", and "Discs, Rupture".

Confirm that these safety devices are properly installed before installing the 316 Vacuum Gauge Controller (VGC). In addition, check that (1) the proper gas cylinders are installed, (2) gas cylinder valve positions are correct on manual systems, and (3) the automation is correct on automated systems.

General Warnings

Improper wiring, programming or operation of the system can result in equipment damage or personnel injury. To avoid these possibilities:

- Program the setpoints for fail-safe operation. Use the setpoint pressure, gauge assignment and polarity setting to provide safe operation in the event of equipment or power failure.
- Label setpoints on the controller front panel to avoid confusion and allow safe manual operation.
- Verify system operation by manually stepping through the control sequence before switching to automatic control. Check that a malfunction in the sequence cannot produce a hazard.
- Install safety devices in the system to limit hazardous conditions. For example, a pressure relief device should be installed on any system using a high pressure gas source.
- Restrict manual operation of the process controls to knowledgeable persons.

Operation of the 316 Vacuum Gauge Controller with line voltage other than that selected by the power supply internal jumpers can cause damage to the instrument and injury to personnel.

The fumes from trichloroethylene, perchloroethylene, toluene, and acetone can be dangerous to health if inhaled. They should be used only in well ventilated areas exhausted to the outdoors. Acetone and toluene are highly flammable and should not be used near an open flame or energized electrical equipment.

Receiving Inspection

On receipt of your equipment, inspect all material for damage. Confirm that the shipment includes all items ordered. If items are missing or damaged, submit a claim as stated below for a domestic or international shipment, whichever is applicable.

If materials are missing or damaged, the carrier that made the delivery must be notified within 15 days of delivery, or in accordance with Interstate Commerce regulations for the filing of a claim. Any damaged material including all containers and packaging should be held for carrier inspection. Contact our Customer Service Department, 6450 Dry Creek Pkwy, Longmont, Colorado 80503, telephone 303-652-4400, if your shipment is not correct for reasons other than shipping damage.

International Shipment

Inspect all materials received for shipping damage and confirm that the shipment includes all items ordered. If items are missing or damaged, the airfreight forwarder or airline making delivery to the customs broker must be notified within 15 days of delivery. The following illustrates to whom the claim is to be directed.

- If an airfreight forwarder handles the shipment and their agent delivers the shipment to customs, the claim must be filed with the airfreight forwarder.
- If an airfreight forwarder delivers the shipment to a specific airline and the airline delivers the shipment to customs, the claim must be filed with the airline.

Any damaged material including all containers and packaging should be held for carrier inspection. If your shipment is not correct for reasons other than shipping damage, contact our Customer Service Department, 6450 Dry Creek Pkwy, Longmont, Colorado 80503, USA, or telephone 303-652-4400.

Limited Warranty

This Brooks Automation Inc./Granville-Phillips product is warranted against defects in materials and workmanship for 18 months from the date of shipment provided the installation, operating and preventive maintenance procedures specified in this instruction manual have been followed. Brooks Automation Inc. will, at its option, repair, replace or refund the selling price of the product if Brooks Automation Inc. determines, in good faith, it is defective in materials or workmanship during the warranty period, provided the item is returned to Brooks Automation Inc. together with a written statement of the problem.

Defects resulting from or repairs necessitated by misuse or alteration of the product or any cause other than defective materials or workmanship are not covered by this warranty. Brooks Automation Inc. expressly disclaims any other warranty whether expressed or implied, including but not limited to the implied warranties of merchantability and fitness for a particular purpose. Under no circumstances shall Brooks Automation, Inc, be liable for consequential or other damages resulting from a breach of this limited warranty.

Chapter 1 - The 316 VGC Control Unit

1.1 Introduction/General Description

The Series 316 Vacuum Gauge Controller (VGC) measures pressures from 1×10^{-4} Torr (1×10^{-4} mbar or 1×10^{-2} pa) to atmosphere, depending on the transducers used.

Modules are available to operate Convectron, capacitance manometer, and thermocouple gauges with three pressures displayed simultaneously.

Pressure readout is via 3 front panel displays, analog output, and available computer interface.

The 316 VGC is a modular instrument which can be easily customized to fit most user's exact needs. Infrequently used controls are housed behind a hinged front panel, reducing front panel clutter and allowing the control unit to reside in a half-rack space.

1.1.1 Available Configurations

Convectron Gauge (CG) Module (Chapter 2)

Permits pressure measurements from 1×10^{-4} to 999 Torr of N_2 from up to three Granville-Phillips Series 275 Convectron Gauges simultaneously. Provides analog output of each indicated pressure.

Thermocouple Gauge (TC) Module (Chapter 3)

Provides the same functions as the Convectron module, but pressure measurement range is 1×10^{-3} Torr to 1 Torr of N_2 .

Capacitance Manometer Module (Chapter 4)

Provides gas-type independent pressure measurement from 1×10^{-4} to 999 Torr depending on the manometer head being used. Allows local range, zero and full scale adjustments and provides power to the transducer. Readout for one Convectron gauge with features as described above is included along with analog outputs for both gauges.

Process Control Module (Chapter 5)

Provides 2 or 6 channels of single pole, double throw relays:

Two channels are associated with each gauge pressure indication. Digital setpoints have switch-selectable polarity for relay activation above or below setpoint. Manual override switches are built-in.

RS-232 Computer Interface Module (Chapter 6)

Provides readout of pressure and process control relay status.

IEEE 488 Computer Interface Module (Chapter 7)

Provides readout of pressure and process control relay status.

RS-485 Computer Interface Module (Chapter 8)

Provides readout of pressure and process control relay status.

Linear Analog Output Module (Chapter 9)

Provides three, zero to +10 Vdc, linearized voltages that correspond to the displayed pressure readings of the 316 Vacuum Gauge Controller.

1.2 Installation

1.2.1 Line Voltage Selection

Line voltages of 90-110 or 105-125 or 220-240 volts are user selectable via jumpers on the power supply PC board within the controller. The factory preset line voltage and fuse rating are marked on the rear panel. Compare your unit to Figure 1-1 to determine if it is configured for your requirements. **Do not apply power until the correct configuration is achieved.**

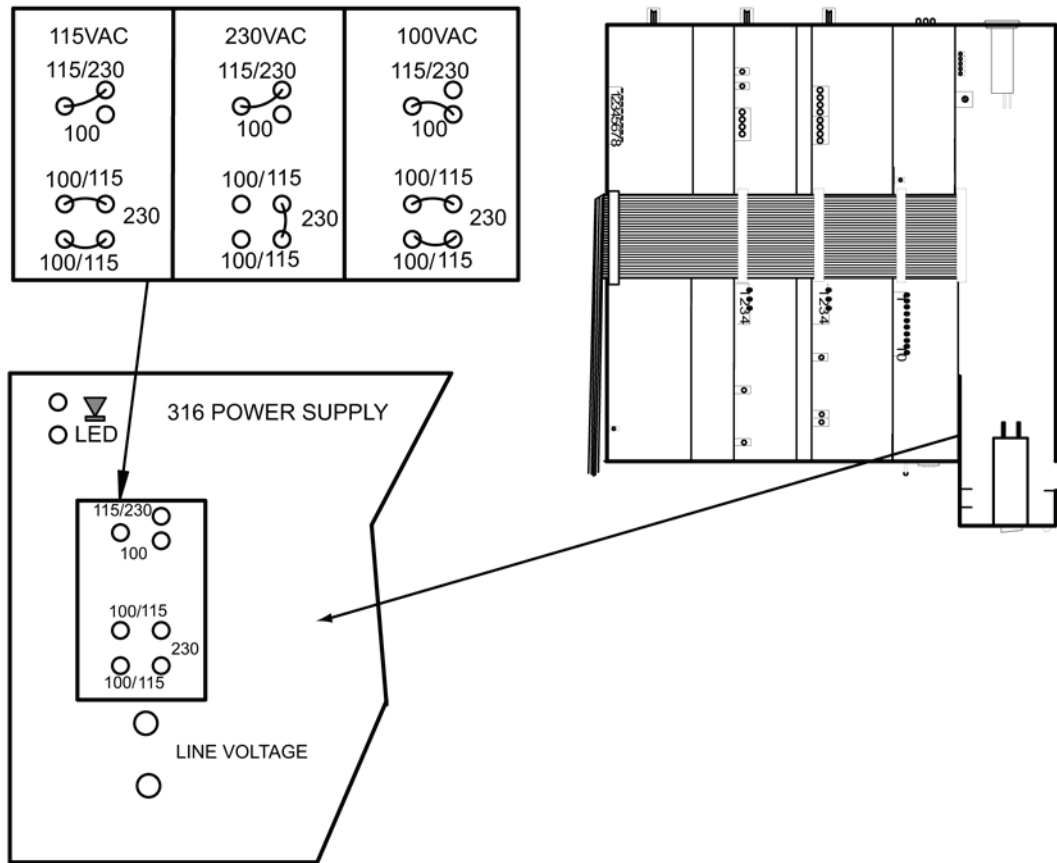

Figure 1-1 Line Voltage Select Jumpers, Power Supply PC Board

1.2.2 Module Installation

Only a Phillips screwdriver is necessary for module installation. The modules for the 316 VGC contain static sensitive devices. Be sure to follow the anti-static procedures outlined in section 1.8.1 when handling printed circuit boards.

The modules for the 316 VGC have metal brackets which interlock to form the front and rear sections of the chassis. Modules must be installed in their proper positions within the chassis (see Figure 1-2).

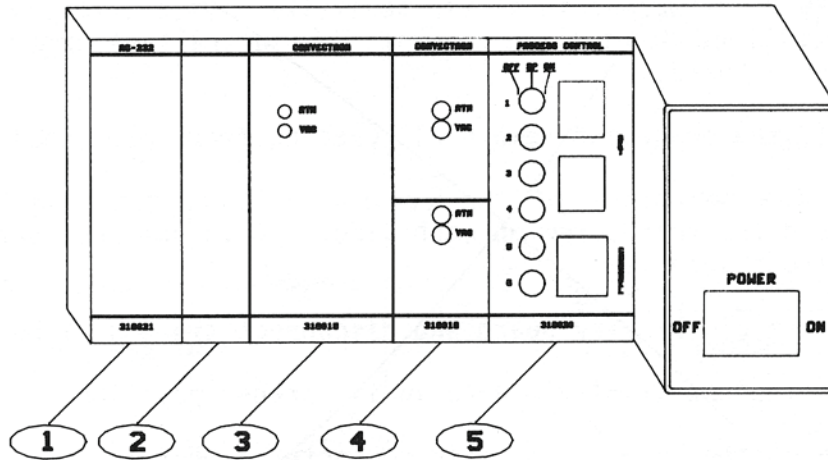

Figure 1-2 Module Positions

1. - Position for computer interface module.
2. - Blank module.
3. - Position for channel A: Convectron or Thermocouple Gauge Module.
4. - Position for channels B & C: Convectron, Thermocouple, or Capacitance Manometer Module
5. - Position for Process Control Module.

1.2.3 To Install a Module

1. Turn OFF the power and remove all cabling from rear panel.
2. Remove the top cover of the controller by removing the upper front screw and the rear screw on each side. It is not necessary to remove the lower front screw.
3. Remove the connectors holding the bus ribbon cable from all boards to the right (when viewed from the front) of the position in which the new module is to be installed. You can also remove the display panel and all connectors to the left.
4. Remove the blank filler module in the position in which the board is to be installed.
5. Install the new module in its proper position. Position all modules so that the chassis segments interlock properly.
6. Re-connect the bus ribbon cable connectors taking care that the columns and rows of the connectors are aligned.
7. Install the top cover, making sure the door hinge pin is correctly located.

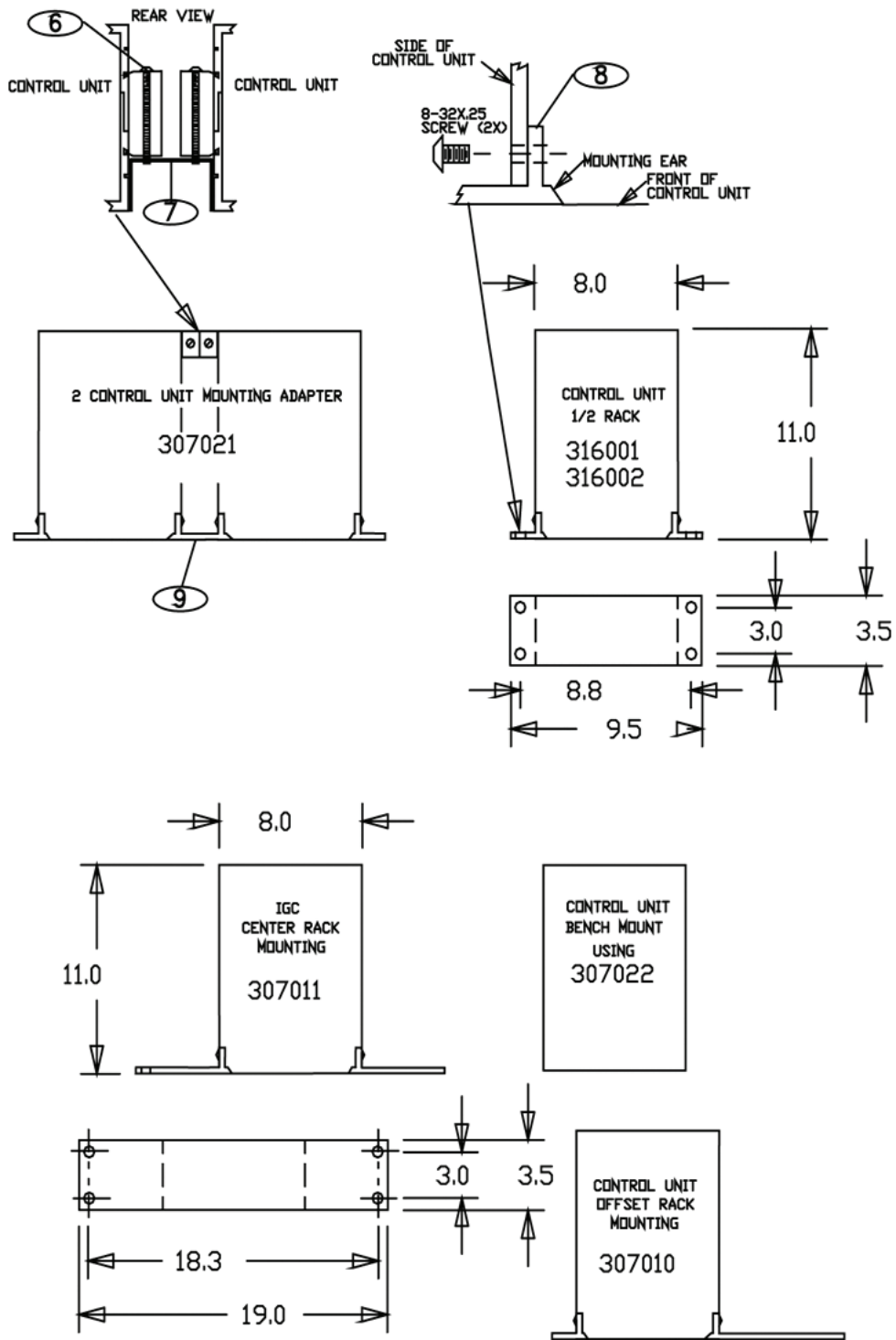

Figure 1-3 Mounting Configurations

1.3 Mounting Configurations

Figure 1-3 illustrates the various configurations available for mounting the 316 control unit and power supply.

Note that when installing a mounting tab (8) into the left side of the control unit, the door should be open.

The bracket (9) used to connect two control units for side by side rack mounting is not symmetrical. Install as shown.

The rear support bracket assembly consists of a U-shaped bracket (7), and two spring clamps (6) which grip into grooves in the side of the control unit.

Note that the 316 Controller should be mounted in a location with free air flow and ambient temperature less than 40 °C.

1.4 Cable Connections

To avoid confusion in cable connections, a set of labels is provided with the cable. The labels are easily attached to the gauge connector with the adhesive backing. The rear panels of the Convector and thermocouple modules are labeled with their respective display designations – A, B and C. See Figure 1-4 for cable connections. Tighten the screws to secure the connectors.

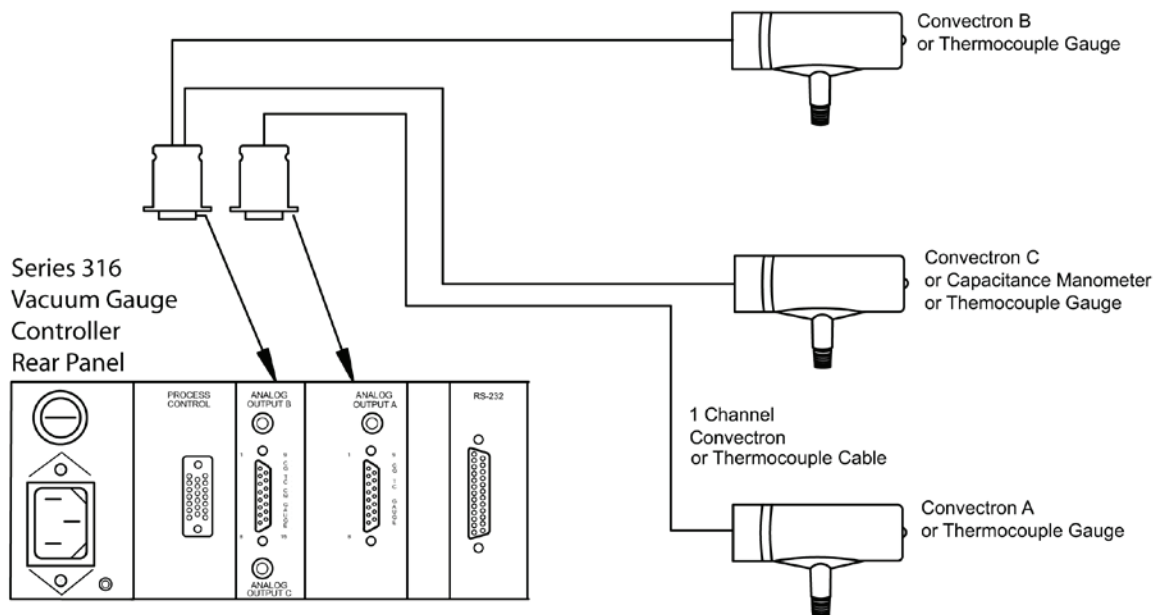

Figure 1-4 Cable Connections

1.4.1 Instrument Grounding

For safe operation, the Series 316 VGC controller must be connected to an AC power source which includes a ground wire. This power ground is generally a sufficient safety precaution. A grounding stud is provided on the rear panel of the power supply module to be used as a separate earth ground. Ground all metal parts of your vacuum system separately to power or earth ground. Do not ground the system via a wire to the 316 VGC chassis. Refer to Figure 1-5.

NOTE: The metal case of the gauge tube does not connect to the controller ground. Electrical connection of the gauge tube envelope to the system does not cause a ground connection between the system and the controller.

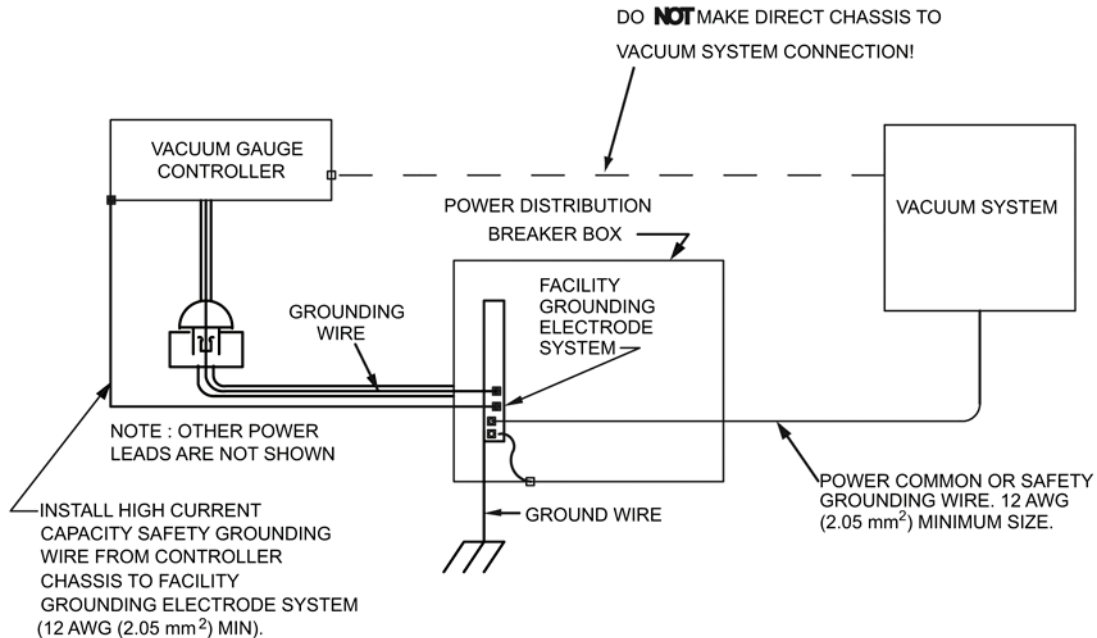

Figure 1-5 Correct System Grounding

1.5 Operation

1.5.1 Summary of Controls and Indicators

A description of the controls and indicators found on a basic 316 VGC is given in this section. For detailed instructions pertaining to particular modules, refer to the chapter for that particular module.

1.5.2 Units of Measure

The unit of measure displayed is selectable via switches on the Convectron, thermocouple and capacitance manometer modules. These units will be indicated on the front panel label when shipped from the factory. See sections 2.2, 3.2, or 4.2 for instructions on changing units of Convectron, thermocouple or capacitance manometer module. The pressure units label (#10 of Figure 1-6) is part of the process control channel label and can be changed by the user if the system of units is changed. Slide the label out from the top.

The pressure is displayed in Torr/millitorr (mbar/mbar $\times 10^{-3}$ or pascal/pascal $\times 10^{-3}$) notation. That is, at pressures below one Torr, the display shows a 10^{-3} exponent, indicating millitorr, while higher pressures display no exponent, indicating Torr.

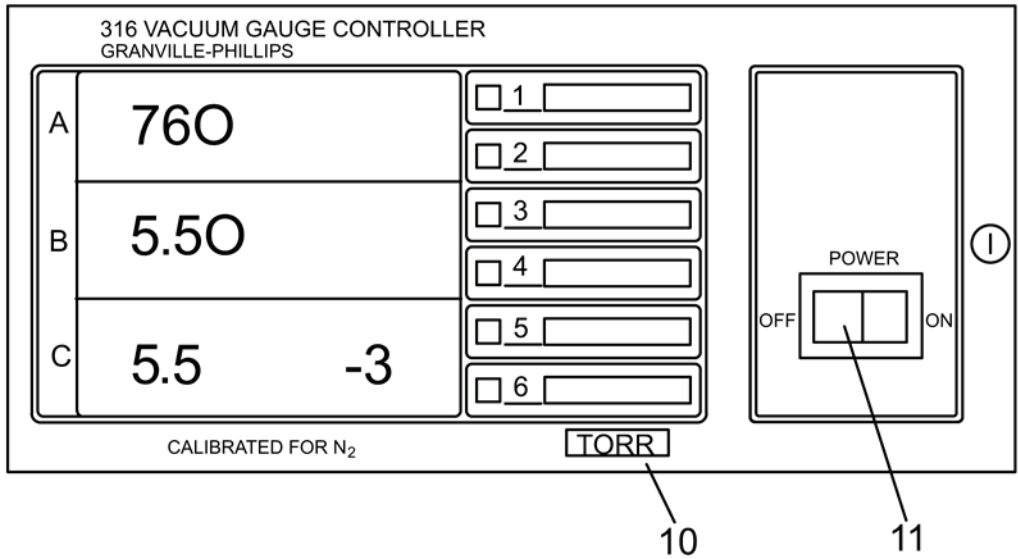

Figure 1-6 Control Unit Front Panel

NOTE: Display units are set separately on the Convectron or thermocouple gauge modules. Adjustments must be made to both gauge modules to avoid confusion. Be certain to update the label to reflect any change of units.

1.6 Theory of Operation

More detailed explanations of the theory of operation of the Convectron, thermocouple and capacitance manometer gauges is provided in sections 2.6, 3.6, and 4.6 respectively.

1.6.1 Microcontrollers and Bus Structure

Each module in the 316 VGC has a dedicated microcontroller with internal ROM, RAM, timing, and interrupt management functions. This architecture provides high-performance at low cost with greater reliability and noise immunity.

Each microcontroller is equipped with a watchdog timer, which automatically generates a reset if the processor fails to fulfill timing "checkpoints" within its code.

Inter-processor communication is accomplished via the display bus. These lines carry BCD-format pressure data which is used to generate the 316 VGC display. The bus is updated once per millisecond. Fifteen cycles are used for display data. Modules that require pressure data, such as process control and computer interface, take it directly from the display update cycles.

1.6.2 Convectron Gauge Theory

Both the Convectron gauge and the thermocouple gauge are heat loss transducers. This causes the response of the gauges to be gas type dependent and non-linear. The Convectron gauge uses feedback amplifier circuitry to maintain the sensor at a constant temperature thus providing greater resolution over a wider pressure range. The thermocouple gauge heater is supplied a constant voltage, thus allowing temperature variation over the pressure range.

1.6.3 Capacitance Manometer Theory

Within the capacitance manometer, a diaphragm is distorted by the pressure of the gas in the system under measurement. This diaphragm forms part of a capacitor, and its deflection causes changes in capacitance. Thus, the electrically measured capacitance is a measure of pressure. The device is very sensitive to the

elastic properties of the metal of the diaphragm. For this reason, large pressure excursions, such as occur when the system is raised to atmospheric pressure, can cause offsets to the pressure reading. The diaphragm is also extremely sensitive to temperature effects, and although it may be held in a temperature controlled chamber, this temperature control is never perfect, resulting in further perturbations to the devices theoretical accuracy. Note that these perturbations are inherent in the capacitance manometer design and are not a property of the electronic module used to operate the transducer.

Capacitance manometers are capable of exceptional accuracy, and read pressure independent of gas type, but are also subject to zero-point drift, and must be calibrated at vacuum frequently if high accuracy is to be obtained. Refer to the manual for your transducer for instructions.

1.7 Calibration

Calibration instructions for each gauge module are contained in the chapter for that module. Convectron gauge calibration is in section 2.5; thermocouple calibration is in section 3.5; capacitance manometer calibration is in section 4.5.

1.8 Basic Troubleshooting

1.8.1 Guidelines

Further troubleshooting information is located in the chapters for the specific modules.

The 316 VGC is designed for easy repair by replacement of modules.

If the user elects to perform repairs at the component level, repairs properly made with equivalent electronic parts and rosin core solder do not represent a violation of the warranty.

Some minor difficulties are user-correctable, and the built-in diagnostic aids described here may be helpful.

Each module has status LEDs which will aid in localizing failures. These are described in the troubleshooting section of the chapters for each module. Shown in Figure1-7 are those LEDs found on the 316 VGC power supply board. This is the PC board on the right side (when viewed from the front) of the 316 control unit.

Since the 316 VGC contains static-sensitive electronic parts, the following precautions must be followed when troubleshooting:

- Use a grounded, conductive work surface.
- Use conductive envelopes to store or ship MOS devices or printed circuit boards.
- Do not operate the 316 VGC with MOS devices removed from the unit.
- Do not handle MOS devices more than absolutely necessary, and only when wearing a ground strap.
- Do not use an ohmmeter for troubleshooting. Rely on voltage measurements.
- Use grounded-type soldering iron only.

Danger – High Voltage

High Voltages are present within the Controller, capable of causing injury or death. Do not touch cable connections or circuitry of the power supply module when power is applied.

1.8.2 Troubleshooting Guide

Symptom	Possible cause
Unit won't power-up, no response to power switch	Power fuse (17) blown Wrong line voltage selection, see Figure 1-1
Power fuse (17) blows repeatedly	Wrong fuse rating Wrong line voltage selection, see Figure 1-1
LED (12) out on control board	+15 volt supply faulty (power to capacitance manometer)
LED (13) out on control board	+12 volt supply faulty (power to analog circuitry and RS232)
LED (14) out on control board	+5 volt supply faulty (power to logic and display)
LED (15) out on control board	-12 volt power faulty (power to analog circuitry and RS232)
LED (16) out on control board	-15 volt supply faulty (power to capacitance manometer)

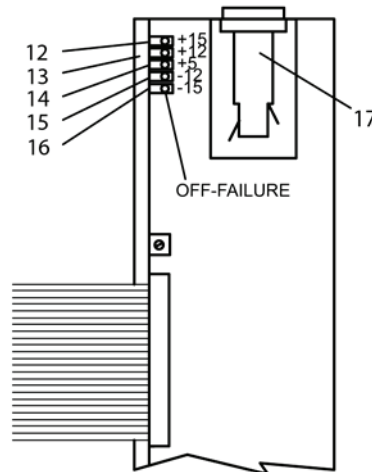

Figure 1-7 Power Supply Board, Top View (Controller Cover Removed)

1.9 Repair Ordering

Telephone Brooks Automation, Inc. to obtain a Return Authorization (RA) prior to returning your unit for repairs.

A repair order must accompany returned equipment even when the equipment is being returned for a warranty repair at no charge. Be sure to include a detailed description of the problem in addition to your name, telephone number and address where we can contact you. Equipment returned for repair must be carefully and strongly packaged to withstand shipping abuse. Components or printed circuit boards to be returned separately must be protected against static damage by wrapping them in static proof containers prior to packaging them for shipment. Address replacement/repair orders and correspondence to the address given on the title page of this manual or as directed by the Customer Service Representative.

A Service Form is provided at the end of this chapter. Photocopy the form, fill in the requested information, including the RA number you were given by a Brooks Automation/Granville-Phillips Customer Support Representative, and include the form with your with your equipment when shipped to the repair center.

If a replacement module is desired, it is important that you give our Service Department the complete catalog number of the module. This will help ensure that you receive the correct replacement.

NOTE: Under no circumstances will Brooks Automation, Inc. be liable for shipping damages due to rough handling, improper packaging, or other circumstances beyond its control. All return shipments must be freight prepaid.

1.10 Specifications (316 Vacuum Gauge Controller)

See the chapters for each module for additional specifications relating to that module.

Physical dimensions and weight

Width	241 mm (9.5 in.) with 1/2 rack mounting tabs
Height	89 mm (3.5 in.)
Depth	356 mm (14 in.) includes 76 mm (3 in.) for connectors and cables
Weight	3 kg (6.6 lb.)

Electrical requirements

Voltage	90-110 Vac or 105-125 Vac or 220 – 240 Vac
Frequency	50 or 60 Hz
Power	100 watts max.
Fuse Ratings	0.5 A (90-125 Vac), 3AG normal blow 0.25 A (220-240 Vac), 3AG normal blow

Operating environment

Temperature	0 °C to 40 °C
IP Rating	IP32

Display information

Display Resolution	Torr/mTorr notation, 3 significant digits (1 digit in lowest decade; 2 digits in next lowest decade)
Display Update Time	0.5 sec typical, 3.0 sec selectable
Units of measure	Torr, millibar, or pascal selectable

Service Form

Photocopy this form, fill it out, and return it with your equipment.

RA No. _____ (Contact Granville-Phillips Customer Service at 1-303-652-4400
or 1-800-776-6543 in the USA; FAX: 1-303-652-2844, or email: co-csr@brooks.com)

Model No. _____ Serial No. _____ Date _____

Name: _____ Phone No. _____

Company: _____

Address: _____

City: _____ State: _____ Zip: _____

Please help Granville-Phillips continue to provide the best possible service by furnishing information that will help us determine the cause of the problem, as well as protect our analysis and calibration equipment from contamination.

Problem description: _____

Application description: _____

Has this product been used with high vapor pressure or hazardous materials? _____ Yes _____ No

If Yes, please list the types of gas, chemicals (common names, specific chemical,) biological materials, or other potentially contaminating or harmful materials exposed to the product during its use.

NOTE: PRODUCTS EXPOSED TO RADIOACTIVE MATERIAL CANNOT BE ACCEPTED BY GRANVILLE-PHILLIPS UNDER ANY CIRCUMSTANCES.

Corporate Officer Signature: _____

Printed Name: _____ Phone No. _____

Chapter 2 - The Convector Gauge Module

2.1 Safety Notices

Be sure to read through this instruction manual before installing, using, or servicing this equipment. If you have any questions or doubts about how to use this equipment safely, contact the Brooks Automation, Inc, Customer Service Department listed at the front of this manual.

2.1.1 Explosive Gases

Do not use the gauge tube when there is danger of explosion from ignition of combustible gas mixtures. The sensing element normally operates at only 125 °C but it is possible that momentary transients or controller malfunction can raise the sensor above the ignition temperature of combustible mixtures which might then explode causing damage to equipment and injuring personnel.

2.1.2 Limitation on Use of Compression Mounts

Do not use a compression mount (quick connect) for attaching the gauge tube to the system in applications resulting in positive pressures in the gauge tube. Positive pressures might blow the tube out of a compression fitting and damage equipment and injure personnel. The Convector gauge should not be used above 1000 Torr (1333 mbar or 1.33×10^5 Pa).

2.1.3 Gauge Tube Mounting Position

If the gauge tube will be used to measure pressures greater than 1 Torr or 1 mbar, the tube must be mounted with its axis horizontal. Although the gauge tube will read correctly below 1 Torr when mounted in any position, erroneous readings will result at pressures above 1 Torr if the tube axis is not horizontal. Erroneous readings can result in over or under-pressure conditions which can damage equipment and injure personnel.

2.1.4 Overpressure

Convector gauges should not be used above 1000 Torr true pressure. Series 316 Controllers are furnished calibrated for N₂. They also measure the pressure of air correctly within the accuracy of the instrument. Do not attempt to use a Convector gauge calibrated for N₂ to measure or control the pressure of other gases such as argon or CO₂, unless accurate conversion data for N₂ to the other gas is properly used. If accurate conversion data is not used or improperly used, a potential overpressure explosion hazard can be created under certain conditions. For example, at 760 Torr of argon gas pressure, the indicated pressure on a Convector gauge calibrated for N₂ is 24 Torr. At an indicated pressure of 50 Torr, the true pressure of argon is considerably above atmospheric pressure. Thus, if the indicated pressure is not accurately converted to true pressure, it is possible to overpressure your system. Overpressure can cause glassware such as ionization gauges to shatter dangerously, and if high enough can cause metal parts to rupture thus damaging the system and possibly injuring personnel. See Section 2.4 for proper use of conversion data.

A pressure relief valve should be installed in the system should the possibility of exceeding 1000 Torr exist.

2.1.5 High Indicated Pressure

For some gases, be aware the indicated pressure will be higher than the true pressure. For example, at a true pressure of 9 Torr for helium the indicated pressure on a Convector gauge calibrated for N₂ is 760 Torr. The safe way to operate the gauge is to properly use accurate conversion data. See Section 2.4 for proper use of conversion data.

2.1.6 Chemicals

Cleaning solvents, such as trichloroethylene, perchloroethylene, toluene and acetone, produce fumes that are toxic and/or flammable. Use only in areas well ventilated to the outdoors and away from electronic equipment, open flames, or other potential ignition sources.

2.1.7 Sensor Failure

If the gauge tube becomes disconnected from the controller or if the sensor wire in the gauge tube fails, the controller will indicate 9.99E+9. If the gauge is unplugged from a powered controller, there might be an instantaneous (0 to 0.2 seconds) drop in the pressure indication and the process control relays could activate for this brief time, depending on the order in which the gauge tube pins break contact.

2.1.8 Gauge Tube Contamination

The calibration of the gauge will be seriously affected by any gas which will attack the gold plated sensor, and could result in over-pressurizing the system. Two primary gases in this category are mercury vapor and fluorine.

2.2 Convectron Module, Introduction

The Convectron Gauge (CG) Module provides pressure measurement from 1.0×10^{-3} Torr (1.0×10^{-3} mbar or 1.0×10^{-1} Pa) to 999 Torr, and one meaningful digit pressure indication down to 1×10^{-4} Torr, air equivalent. The basic 316 VGC displays pressure from one Convectron gauge in display "A" via the single channel, "A", Convectron module. Two additional pressures from Convectron gauges can be displayed in displays "B" and "C" via the dual channel "B" and "C" module. These gauges, modules, and displays are designated "CGA", "CGB", and "CGC" in this manual.

Analog output (logarithmic in pressure, 1 volt per decade) is also provided through the phone jack(s) on the rear panel. When used with the Process Control Module, CGA controls setpoints 1 and 2, CGB controls setpoints 3 and 4, and CGC controls setpoints 5 and 6.

2.2.1 Units of Pressure Measurement

Your Series 316 Controller was shipped from the factory preset to display the unit of measure, Torr, millibar, or pascal, that you requested. If you want to change the display units, proceed as follows:

1. Remove the power cord from the control unit.
2. Remove the top cover and locate the Convectron Module. See Figure 2-1
3. Locate the millibar (#1), and the pascal (#2) units switches.
4. Leave both switches open for Torr units; close the appropriate switch for either millibar or pascal units.
5. Modify the units of measure of the Convectron "B and C" module similarly to be consistent with the Convectron "A" module.
6. Slip the label card out of the top of the front panel and apply the appropriate pressure units label.

Note: The Slow Update Switch is a display update rate switch. "ON" enables pressure averaging, and the display will update approximately every 3 seconds. When "OFF", the update period is approximately 0.5 sec.

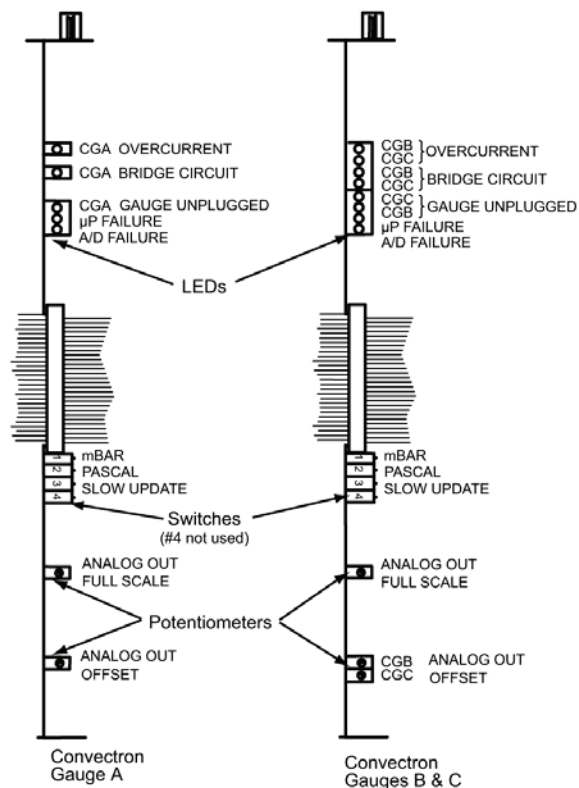

Figure 2-1 Convectron Modules, Top View (Controller Cover Removed)

2.3 Convectron Gauge Tube Installation

The following precautions in the use and installation of the Convectron Gauge tube must be observed.

- Observe the precautions at the front of this chapter regarding tube mounting position and high pressure operation.
- The gauge tube should be installed with the port oriented vertically downward to ensure that no system condensates or other liquids collect in the gauge tube.
- Keep the gauge tube clean. Do not remove the mounting port cover until you are ready to install the gauge tube.
- **Do not** mount the gauge tube in a manner such that deposition of process vapors upon the internal surfaces of the tube can occur through line-of-sight access to the interior of the gauge tube.
- **Do not** install the gauge tube where high amplitudes of vibration are present. Excessive vibration will cause forced convection at high pressure giving erroneous readings.
- **Do not** bake the tube to temperatures above 150 °C.
- **Do not** install the gauge tubes where they will be exposed to corrosive gases such as mercury vapor, chlorine, or fluorine, which will attack the gold plated sensor.
- For greatest accuracy and repeatability the gauge tube should be located in a stable room temperature environment.

2.3.1 Gauge Tube Orientation

It is important to consider the orientation of the gauge tube if accurate readings above 1 Torr are desired.

Below 1 Torr: The gauge tube will operate and accurately measure pressure below 1 Torr when mounted in any orientation.

Above 1 Torr: The gauge tube will accurately measure pressures above 1 Torr only when mounted with its axis horizontal, preferably with the port pointing vertically downward, as shown in Figure 2-2. It is valuable to point the port downward to facilitate the removal of condensation and other contaminants.

Furthermore, the gauge is factory calibrated with the port pointing vertically downward. Installation of the gauge with the port in other orientations can affect the accuracy of the indicated pressure.

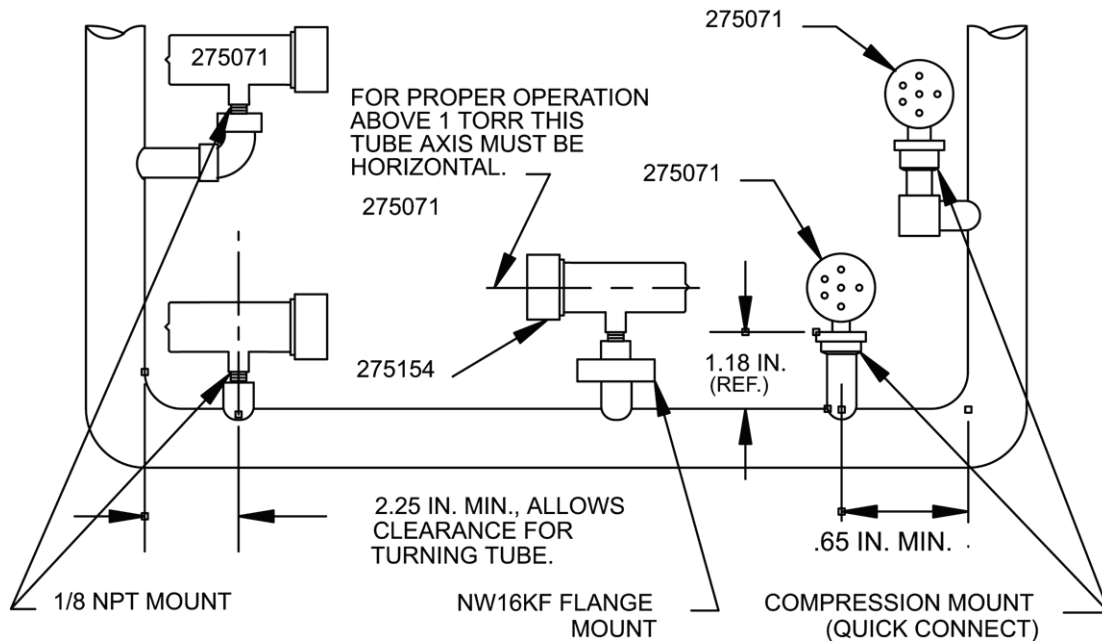

Figure 2-2 Convectron Gauge Mounting Clearances

Compression Mount (Quick Connect)

Do not use Compression Mount for positive pressure applications.

The gauge tube port is designed to fit a standard 1/2 in. compression (quick connect) mount such as the Cajon Co.® Ultra-Torr® fittings.

Remove the caplug from the gauge tube port, insert the gauge tube port into the compression fitting and finger tighten the press ring. If a seal is not achieved it could be due to extreme cleanliness of the O-ring. A light film of vacuum grease such as Apiezon will insure sealing and is normally preferable to the use of pliers or pipe wrench to further tighten the press ring. You can point the electrical pins of the gauge tube anywhere you desire in a 360 degree horizontal circle for optimum routing of the gauge tube cable.

1/8 NPT Mount

The threads on the gauge tube port will fit a standard 1/8 NPT female fitting. Wrap the threads of the gauge tube port with Teflon® tape and screw these threads into the system fitting hand tight. Do not use any wrench or tool. The gauge tube body functions adequately as its own wrench. Tighten only sufficiently to achieve a seal. When the threads are tightened to the point where a seal is just achieved, about one-half turn additional tightening is all that can be gained without overstressing the tube port.

NW16KF Flange Mount

The KF mounting system requires an O-ring and centering ring to be placed between the mating flanges. The flanges are then held together with the aluminum flange clamp by tightening the wing nut. Maximum pressure for this style mounting system is 1000 Torr absolute.

Other Mounting Options

The Convector gauge is also available in several other mounting systems. These include Cajon[®] SS-4-VCR[®]-1, SS-4-VCR-3, and SS-6-VCO[®]-1 fittings, 2-3/4 inch rotatable and non-rotatable CuSeal flanges, 1-5/16 inch non-rotatable CuSeal flange, and welded NW16 and NW25 SST flanges.

2.4 Convector Gauge Operation

2.4.1 Reading Pressure

WARNING

If used without proper calibration or without reference to proper calibration tables, Convector gauges can supply misleading pressure indications. This can result in dangerous overpressure conditions within the system. As supplied from the factory, the controller is designed to read pressure for nitrogen. For use with any other gases, consult the gas type correction charts found later in this section.

Convector gauge pressures are indicated in the 316 display with two or three significant digits of resolution above one millitorr and one significant digit in the 10^{-4} Torr decade. The pressure is displayed in Torr/millitorr (mbar/mbar $\times 10^{-3}$ or pascal/pascal $\times 10^{-3}$) notation. That is, at pressures below one Torr, the display shows a 10^{-3} exponent indicating millitorr while higher pressures display no exponent, indicating Torr.

Special Considerations For Use Below 10^{-3} Torr

During a fast pumpdown from atmosphere, thermal effects will prevent the Convector from tracking pressure rapidly below 10^{-3} Torr. After about 15 minutes, readings in the 10^{-4} range will be valid and response will be rapid. Calibration at vacuum can be performed at this time, or sooner if readings in the 10^{-4} range are not needed.

The 10^{-4} Torr range is accurate to about 0.1 millitorr provided the instrument has been carefully zeroed at vacuum. See Section 2.4 for vacuum and atmosphere calibration procedures. For accurate use in the 10^{-4} Torr range, zeroing should be repeated frequently.

Use With Gases Other Than N₂ and Air

Before using the Convector gauge to measure the pressure of other gases make certain the ATM adjustment is correctly set for air. See Section 2.5.

It is important to understand that the indicated pressure on a Convector gauge depends on the type of gas in the gauge tube, and on the orientation of the gauge tube axis as well as on the gas pressure in the gauge tube. Convector gauges are supplied calibrated for N₂ within the accuracy of the instrument. With certain safety precautions, the Convector gauge can be used to measure pressure of other gases.

Convector gauge tubes are thermal conductivity gauges of the Pirani type. These gauges transduce gas pressure by measuring the heat loss from a heated sensor wire maintained at constant temperature. For gases other than N₂ and air the heat loss is different at any given true pressure and thus the indicated reading will be different.

Indicated vs. True Pressure Curves

Figures 2.3, 2.4, 2.5, 2.6, 2.7 and 2.8 show the true pressure vs. indicated pressure of Convector Gauge for eleven commonly used gases. The following list will help to locate the proper graph for a specific application:

Figure	Range and Units	Gases
2.3	0.1 to 100 millitorr	All
2.4	0.1 to 1000 Torr	Ar, CO ₂ , CH ₄ , Freon 12, He
2.5	0.1 to 1000 Torr	D ₂ , Freon 22, Kr, Ne, O ₂
2.6	1 x 10 ⁻⁴ to 0.1 mbar	All
2.7	0.1 to 1000 mbar	Ar, CO ₂ , CH ₄ , Freon 12, He
2.8	0.1 to 1000 mbar	D ₂ , Freon 22, Kr, Ne, O ₂

Note that 1 mbar = 100 pascal, so the mbar charts can be used for pascal units by multiplying the values on the axes by 100.

A useful interpretation of these curves is, that at a true pressure of 2×10^{-2} Torr of CH₄ the heat loss from the sensor is the same as at a pressure of 3×10^{-2} Torr of N₂ (see Figure 2-3). The curves at higher pressure vary widely from gas to gas because the thermal losses at higher pressures are greatly different for different gases.

The Convector Gauge tube uses convection cooling to provide resolution superior to any other thermal conductivity gauge near atmospheric pressure of N₂ and air. Because convection effects are geometry dependent, the true pressure vs. indicated pressure curves for the Convector Gauge tube are likely to be much different from curves for heat loss tubes made by others. Therefore, **it is not safe to attempt to use calibration curves supplied by other manufacturers for their gauges with the Convector Gauge, nor is it safe to use curves for the Convector Gauge with gauges supplied by other manufacturers.**

If you must measure the pressure of gases other than N₂ or air, use Figures 2-3 through 2-8 to determine the maximum safe indicated pressure for the other gas as explained below.

Example 1: Maximum safe indicated pressure.

Assume a certain system will withstand an internal pressure of 2000 Torr or 38.7 psia. For safety you want to limit the maximum internal pressure to 760 Torr during backfilling. Assume you want to measure the pressure of argon. On Figure 2-4, locate 760 Torr on the left hand scale, travel to the right to the intersection with the argon (Ar) curve and then down to an indicated pressure of 24 Torr (N₂ equivalent). Thus in this hypothetical situation the maximum safe indicated pressure for argon is 24 Torr.

For safety, it is prudent to place a warning label on the instrument face which under the assumed conditions would read "DO NOT EXCEED 24 TORR FOR ARGON."

Example 2: Indicated to true pressure conversion.

Assume you want to determine the true pressure of argon in a system when the Convector is indicating 10 Torr. On Figure 2-4, read up from 10 Torr (N₂ equivalent) indicated pressure to the argon curve and then horizontally to the left to a true pressure of 220 Torr. Thus 220 Torr argon pressure produces an indication of 10 Torr (N₂ equivalent).

Example 3: True to indicated pressure conversion.

Assume you want to set a process control setpoint at a true pressure of 20 Torr of CO₂. On Figure 2-4, locate 20 Torr on the true pressure scale, travel horizontally to the right to the CO₂ curve and then down to an indicated pressure of 6.5 Torr (N₂ equivalent). Thus, the correct process control setting for 20 Torr of CO₂ is 6.5 Torr (N₂ equivalent).

Example 4: True to indicated pressure conversion.

Assume you want to obtain a helium pressure of 100 Torr in the system. On Figure 2-4, locate 100 Torr on the left hand scale, travel horizontally to the right to attempt to intersect the He curve. Because the intersection is off scale it is apparent that this true pressure measurement requirement for helium exceeds the capability of the instrument.

For gases other than those listed, the user must provide accurate conversion data for safe operation.

The Convectron gauge is not intended for use above 1000 Torr true pressure.

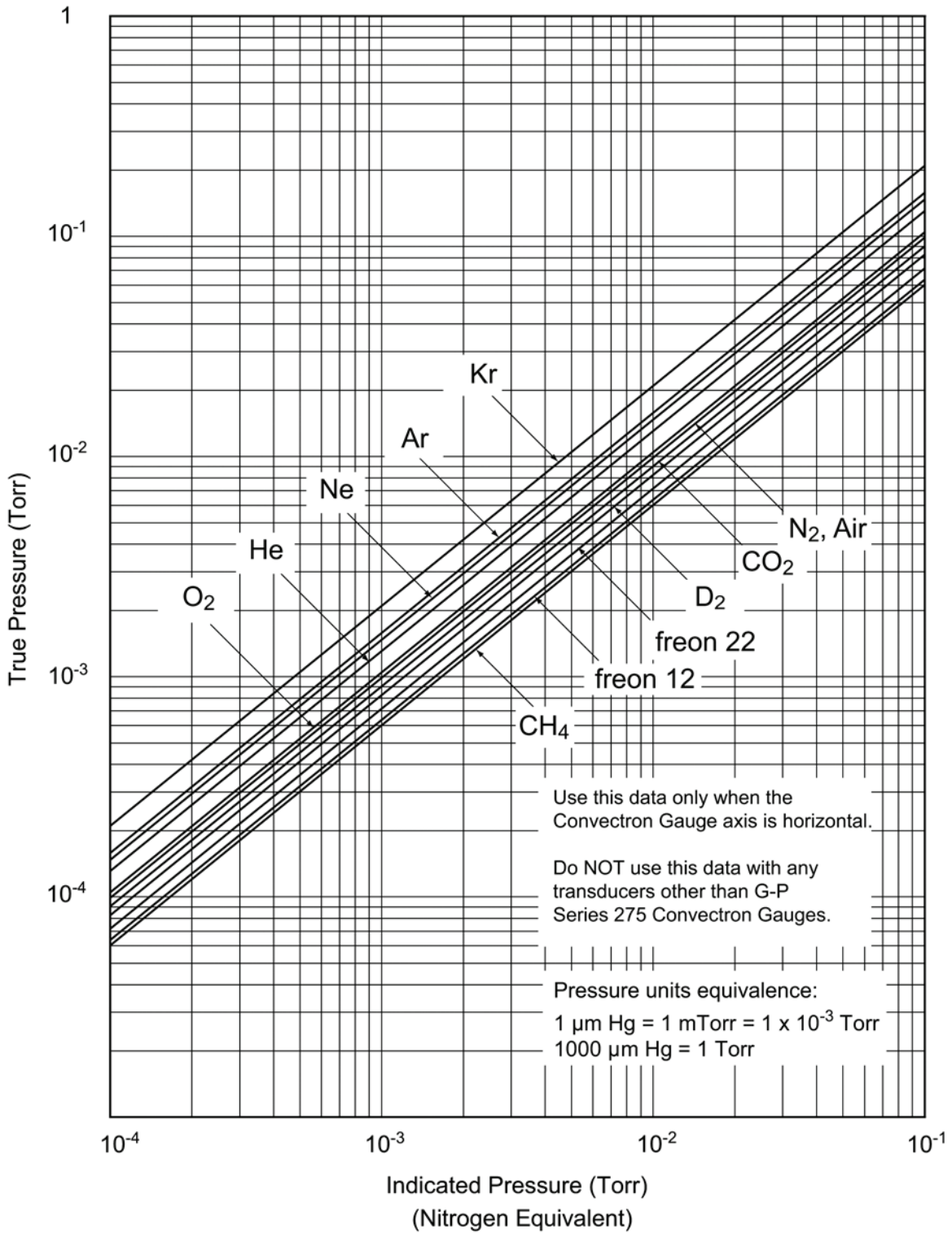

Figure 2-3 Convectron Gauge Indicated vs. True Pressure Curve; 0.1 to 100 mTorr

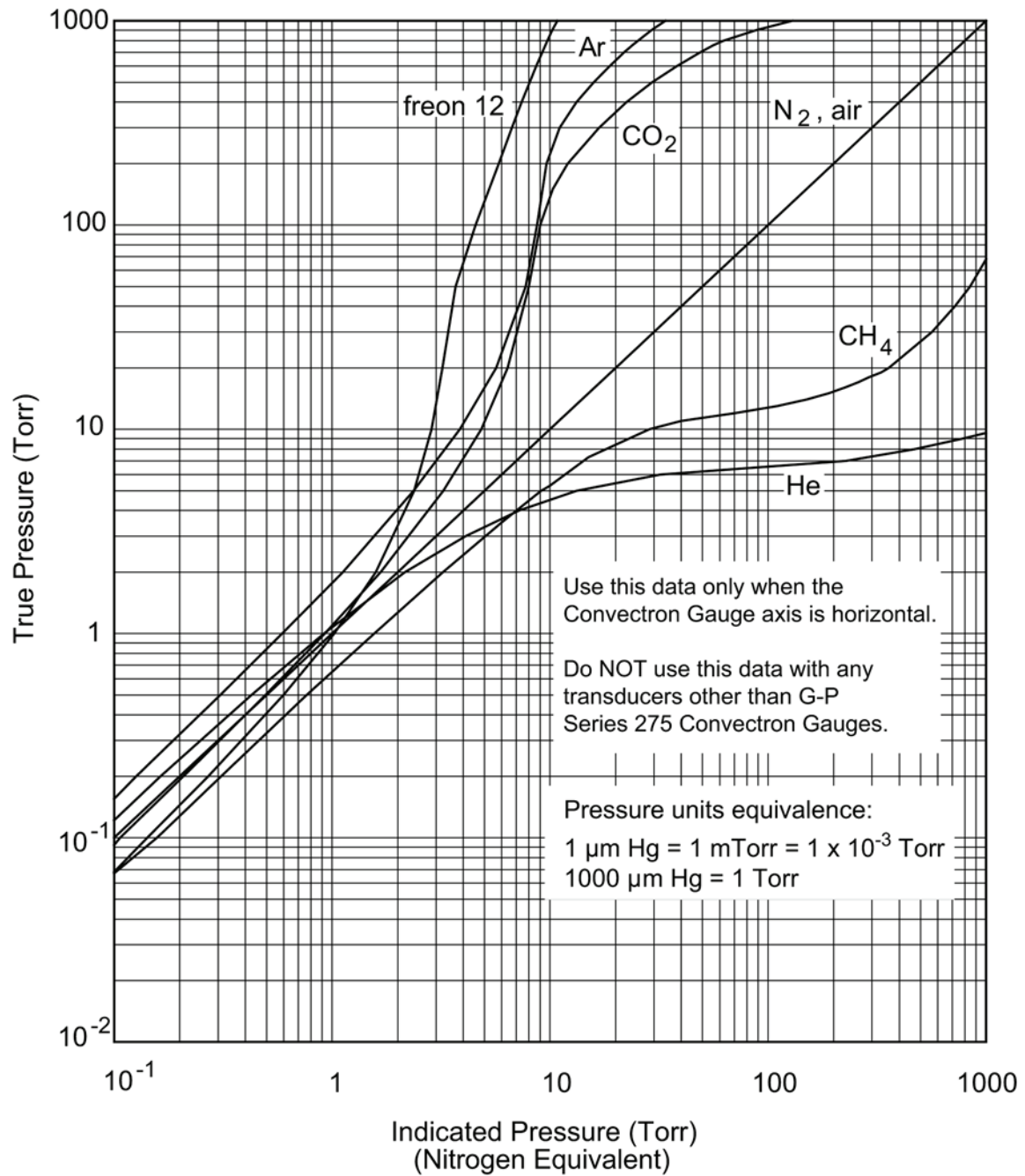

Figure 2-4 Convectron Gauge Indicated vs. True Pressure Curve; 0.1 to 1000 Torr

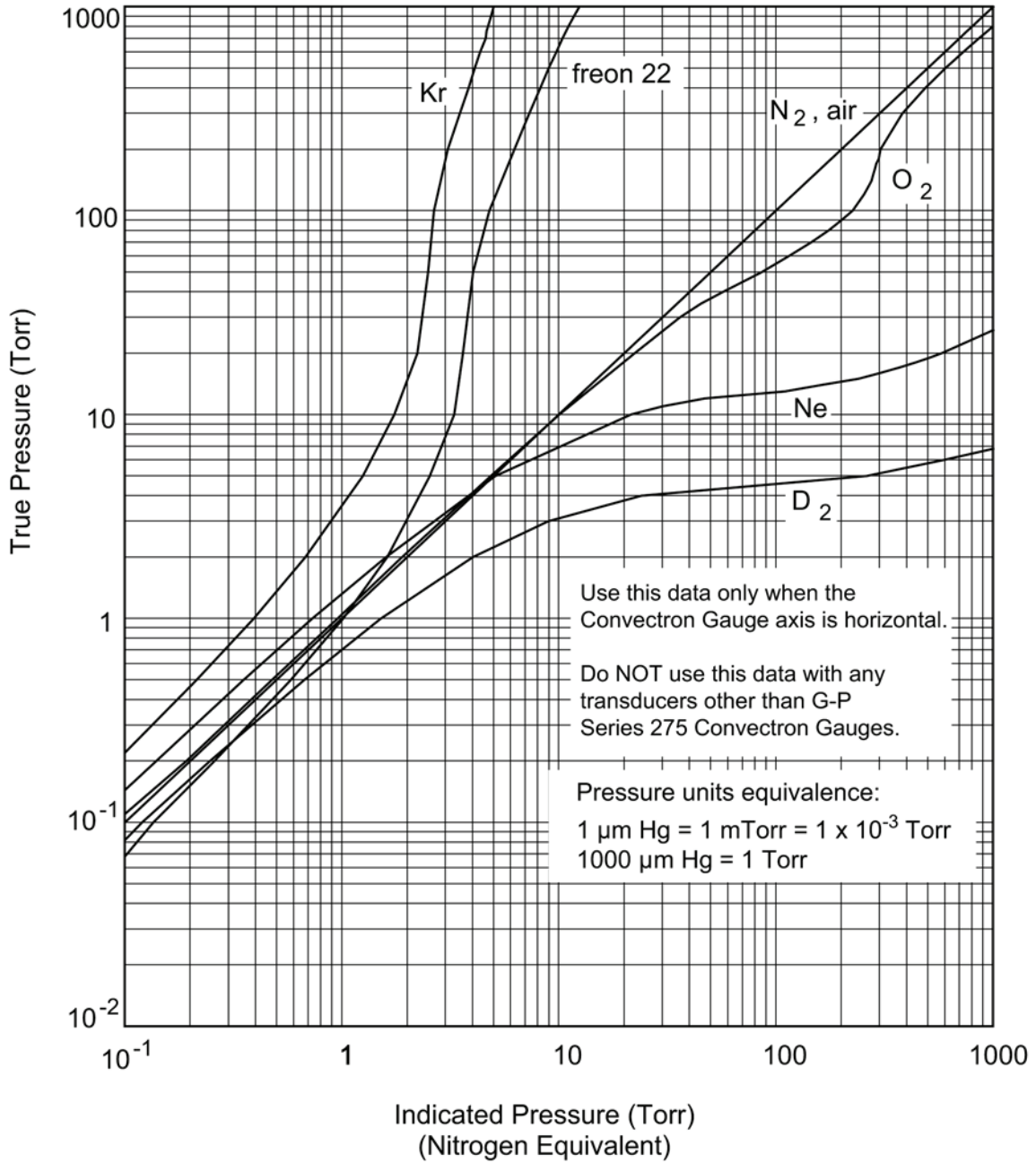

Figure 2-5 Convectron Gauge Indicated vs. True Pressure Curve; 0.1 to 1000 Torr

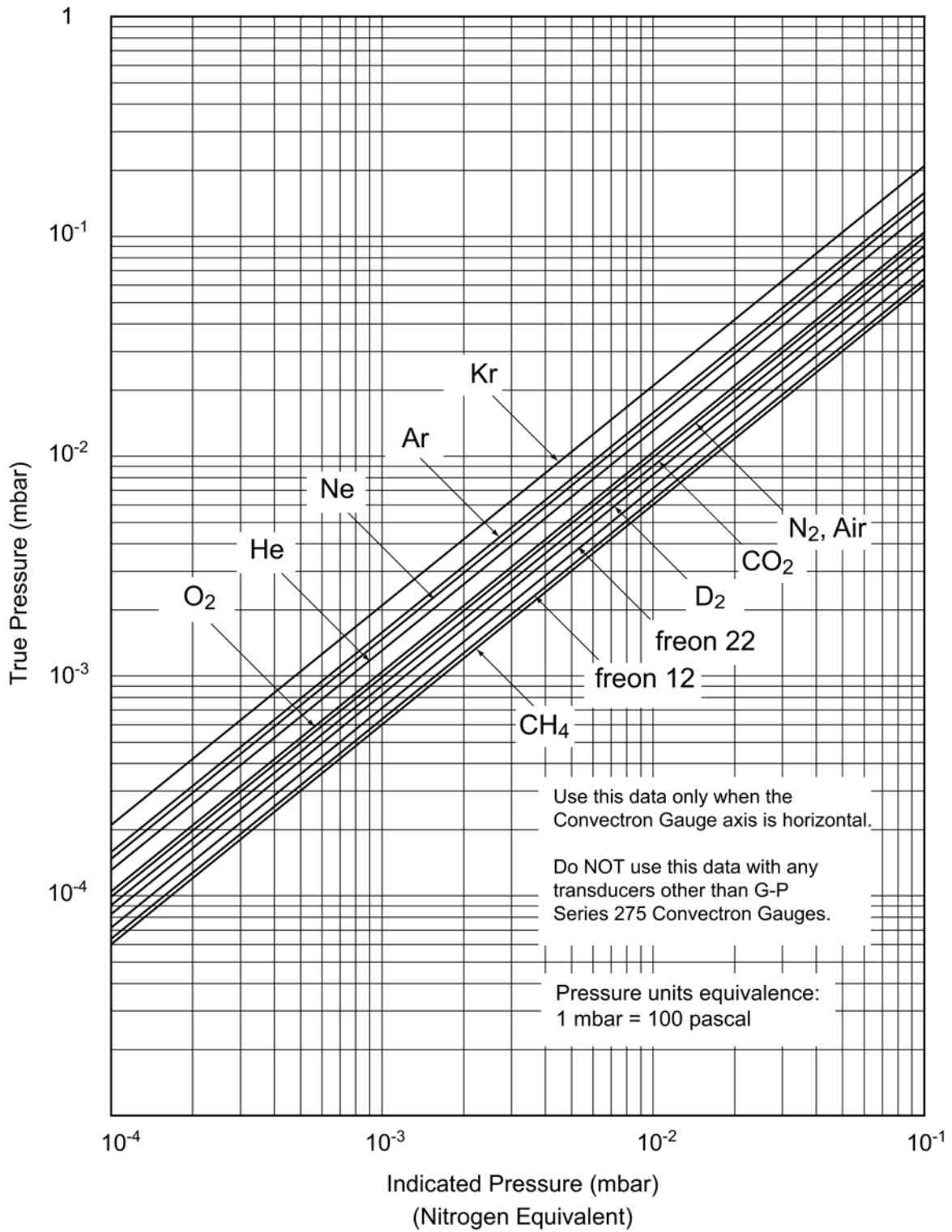

Figure 2-6 Convectron Gauge Indicated vs. True Pressure Curve; 10^{-4} to 0.1 mbar

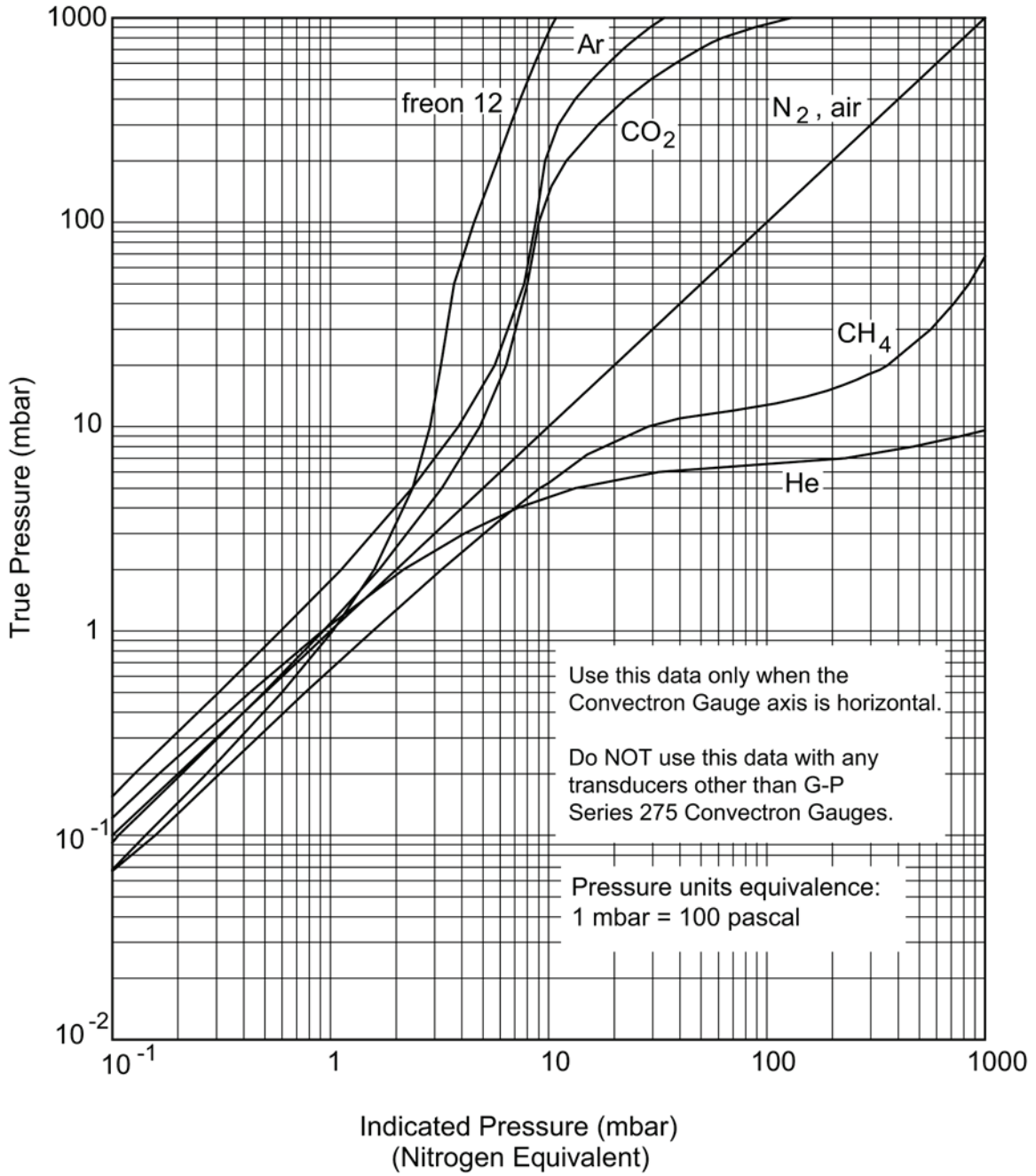

Figure 2-7 Convectron Gauge Indicated vs. True Pressure Curve; 0.1 to 1000 mbar

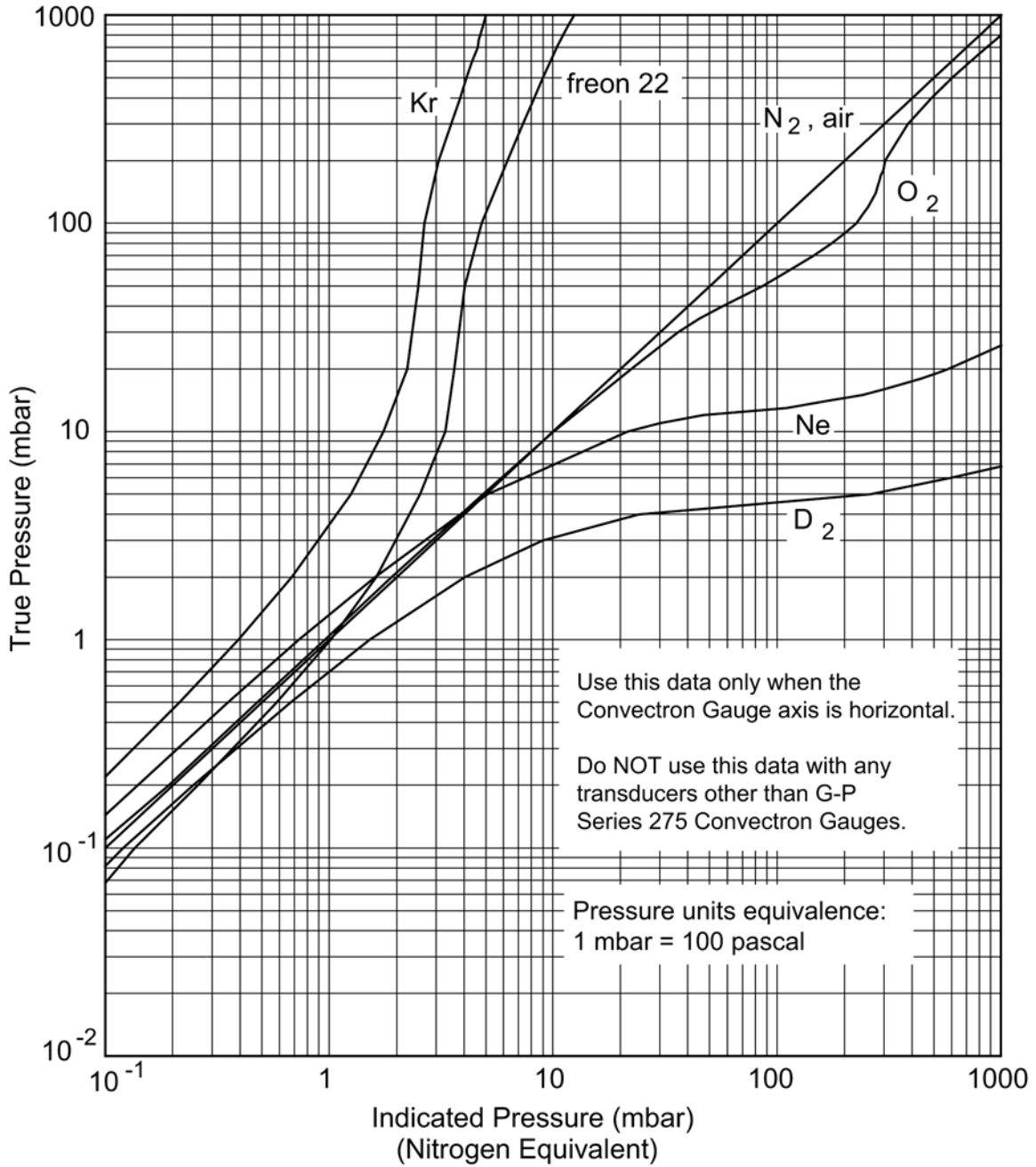

Figure 2-8 Convectron Gauge Indicated vs. True Pressure Curve; 0.1 to 1000 mbar

2.4.2 Analog Output

An analog output for each gauge is provided on the rear panel. See Figure 2-9. These are dc voltages proportional to the logarithm of the pressure, scaled to 1 volt per decade: 0 volts = 1×10^{-4} or less, Torr or mbar, 1 volt = 1×10^{-3} , etc.

For pascal units, the analog output will be scaled to 0 volts = 1×10^{-2} Pa.

Internal offset adjustments are provided which allow a shift in the analog output at 10^{-4} Torr away from 0 volts to anywhere in the range -7 to +1 V. This adjustment does not affect the slope of the analog output vs. pressure curve. See Section 2.4 for adjustment.

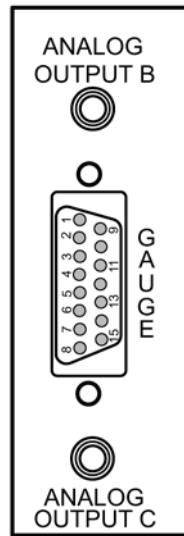

Figure 2-9 Convector Module, Rear Panel

Standard 1/8" miniature phone jack connectors are provided for the analog output.

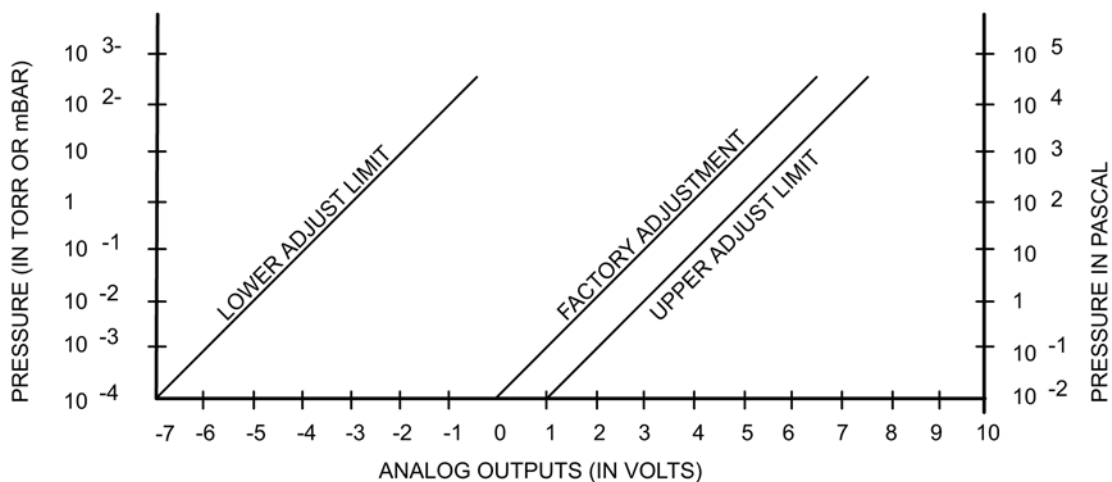

Figure 2-10 Convector Gauge Pressure Analog Output.

2.5 Convectron Gauge Calibration and Maintenance

Each Convectron gauge tube is individually calibrated for N₂ and air prior to leaving the factory. The Convectron gauge tube itself has a temperature compensated design. Each controller is also individually calibrated to provide accurate readout of N₂ and air pressure with any calibrated tube. Therefore, initial calibration should not be necessary.

Calibration should be performed if accurate readings in the 10⁻⁴ Torr range are desired, if the tube becomes contaminated, does not read correctly, or to readjust for use with long cables. For accurate calibration, the vacuum and atmosphere adjustments must be made in the following order. The gauge and controller can be calibrated as a system by performing the following procedures

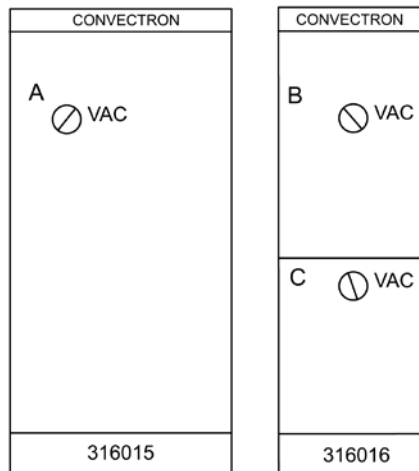

Figure 2-11 Convectron Modules, Front Panels

2.5.1 Zero Adjustment (VAC)

Evacuate the system to a pressure less than 1 x 10⁻⁴ Torr.

With the gauge tube operating, adjust the VAC potentiometer until 0.0 0 shows in the display. Note that if the adjustment is turned too far below zero, a minus sign will appear before the exponent (0.0 -0). Thus proper zero calibration is achieved when only 0.0 0 appears.

2.5.2 Atmosphere Adjustment (ATM)

Allow the system pressure to rise to atmospheric pressure of N₂ or air.

Adjust the ATM potentiometer until the pressure displayed agrees with the absolute pressure as read on an accurate barometer. Use absolute pressure, not corrected to sea level.

1 atmosphere normal at sea level = 760 Torr = 1.00⁺³ mbar = 100⁺³

2.5.3 Analog Output Full Scale Adjustment

This potentiometer can be adjusted to calibrate the span of the analog output voltage to the factory setting of 1 volt per decade. This adjustment is common to both outputs. See Figure 2-12.

2.5.4 Analog Output Offset; Gauges A, B, and C

These potentiometers provide adjustable offset voltages to each analog output. The range of this adjustment allows setting the analog output at vacuum (P = 1 x 10⁻⁴ Torr) anywhere in the range -7 to +1 Vdc. See Figures 2-10 and 2-12.

The factory calibration is established by adjusting the potentiometers to 0-volt outputs when both gauges are at vacuum (pressure less than 1 x 10⁻⁴ Torr), then adjusting to increase 1 volt for each decade the pressure increases.

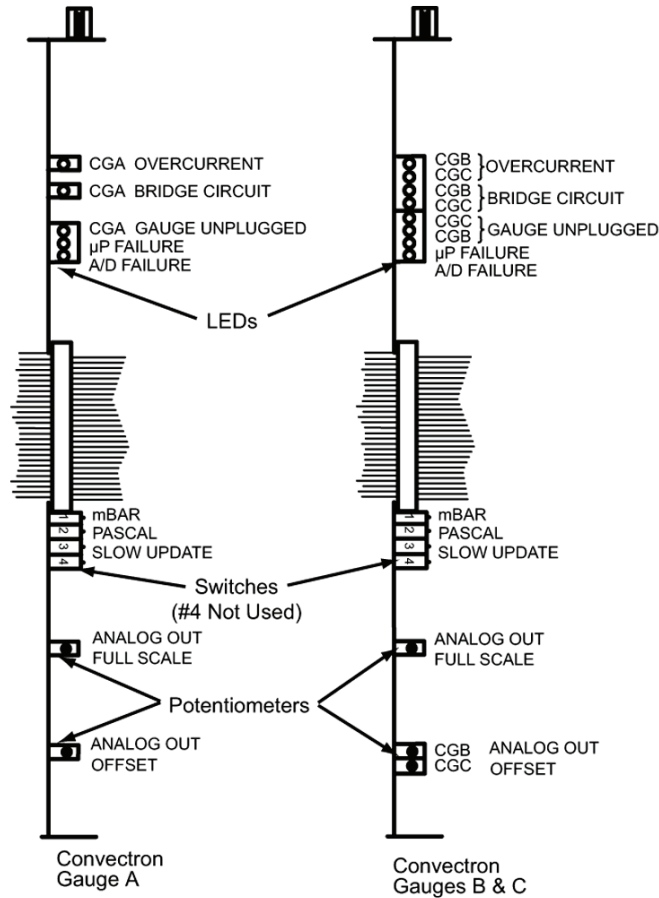

Figure 2-12 Convectron Modules, Top View (Controller Cover Removed)

2.5.4 Cleaning the Gauge Tube

The Convectron gauge can be baked to 150 °C. See Section 2.6 on for a list of materials exposed to vacuum.

When the fine sensor wire is so contaminated with oil or other films that its emissivity or its diameter is appreciably altered, a change of calibration will result. Cleaning with trichloroethylene, perchloroethylene, toluene, or acetone is possible but it must be done very carefully so as not to damage the sensor.

CAUTION:

The fumes from any of these solvents can be dangerous to your health if inhaled and should be used only in well ventilated areas exhausted to the outdoors. Acetone and toluene are highly flammable and should be used away from open flame or electrical equipment.

Hold the gauge tube with the main body horizontal and the port projecting upward at an angle of 45 degrees and slowly fill it with solvent using a standard wash bottle with the spout inserted in the port to where it touches the screen. Let the solvent stand in the tube for at least ten minutes. **Do not shake the gauge tube** if the tube is only partially filled as liquid forces on the sensor can become large enough to affect the transducer calibration. If the tube is completely filled, shaking is not helpful. To drain the tube, position it horizontally with the port facing downward. By slightly warming the tube, a positive pressure will build up internally forcing the solvent out past the screen. Then allow tube to dry overnight with port vertically downward and uncapped. Be certain no solvent odor remains before reinstalling the tube on the system.

2.6 Theory of Operation

The Convector transducer is represented in Figure 2-13 as R1, R2, R3, and R4. These four resistances form the legs of a bridge circuit, with R1 designating the sensor wire of the transducer. R2 is a resistive network in the tube which compensates for changes in the ambient temperature. At bridge null:

$R1 = R2 \times R3 / R4$. If there are no changes in ambient temperature, the value of R1 is a constant and the bridge is balanced.

As the vacuum system pressure is decreased, there are fewer molecules in the system to conduct the heat away from the sensor wire causing the temperature and resistance of R1 to increase. The increased resistance of R1 causes the bridge to unbalance and a voltage is developed across the null terminals. The bridge control circuit senses the null voltage and decreases the voltage across the bridge until the null voltage is again zero. When the bridge voltage is decreased, the power dissipated in the sensor wire is decreased causing the resistance of R1 to decrease to its previous value. The opposite events happen for a pressure increase. The bridge voltage is a non-linear function of pressure.

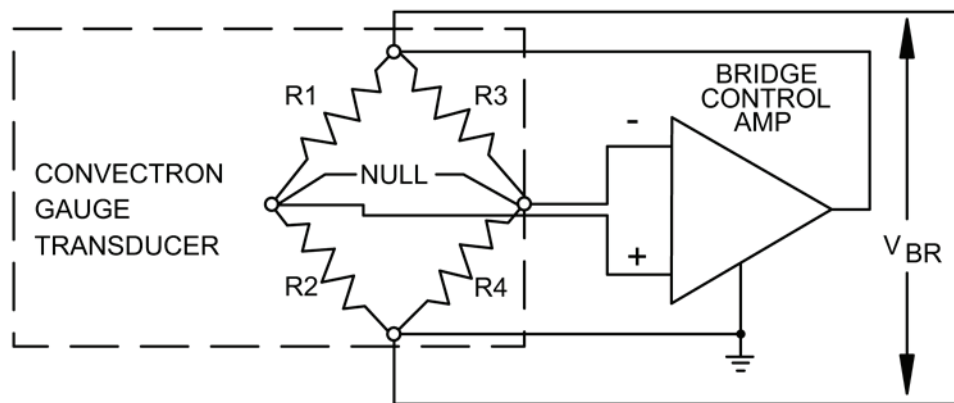

Figure 2- 13 Simplified Schematic of the Convector Gauge

All materials have been chosen for ultra high vacuum service, corrosion resistance and bakeability to 150 °C. The gauge tube envelope is type 304 stainless steel. All metallic joints in the envelope are welded. No solder is used within the envelope. The following materials are exposed to the vacuum: Type 304 stainless steel, Carpenter Alloy 52, Kovar, Kapton gold plated tungsten, and borosilicate glass and Dow Corning 9015 glass. The blue trim cover is molded of polysulfone thermoplastic suitable for service to 150 °C.

2.7 Convector Gauge Troubleshooting

2.7.1 Transducer Test Procedure

Do not perform electrical continuity tests with instruments applying in excess of 1 volt when the tube is at vacuum, or 5 volts when at atmospheric pressure.

The 275 transducer should show the following resistances (pin numbers are embossed on the transducer cap):

Pins 1 to 2	20 to 25 ohms
Pins 2 to 3	50 to 60 ohms
Pins 1 to 5	175 to 190 ohms
Any pin to envelope	open circuit

If the resistance from pin 1 to 2 is about 800 ohms, the sensor wire is broken.

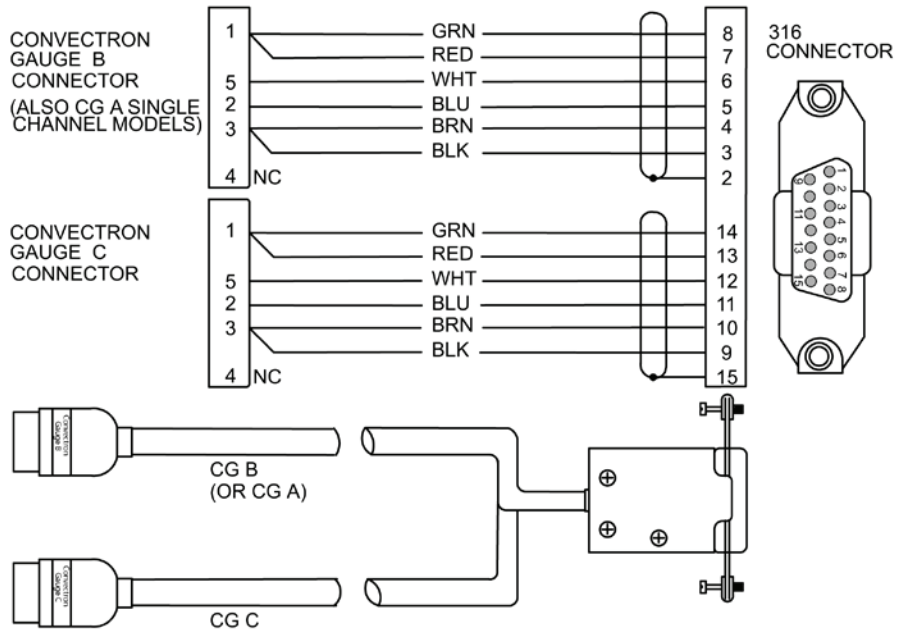

Figure 2-14 Convectron Cable Diagram

2.7.2 Convectron Troubleshooting Guide

Refer to Figure 2-12 for the location of the LEDs listed in this guide.

Symptom	Possible Cause
Over Current LED is illuminated	<ol style="list-style-type: none"> 1. Cable has an electrical short. 2. Short between pins 1 and 3 on the Convectron Gauge
Bridge Circuit LED is illuminated	Bridge amplifier circuit failure
Gauge Unplugged LED is illuminated	<ol style="list-style-type: none"> 1. Cable between the Controller and the gauge tube is unplugged or has a broken wire. 2. Broken sensor wire inside the gauge tube.
Microprocessor (μ P Failure) LED is illuminated	Microprocessor failure
AD Failure LED is illuminated	A/D Integration failure
Display reads 9.99 +9	Broken sensor wire inside the gauge tube.
Display reads – (Minus)	Cable between the Controller and the gauge tube is unplugged.
Pressure reading is very inaccurate	<ol style="list-style-type: none"> 1. Controller out of calibration. 2. Unknown gas type. 3. Gauge mounted in an improper orientation. 4. Sensor damaged by a reactive gas. 5. Gauge tube contaminated. 6. Temperature extremes. 7. Mechanical vibration.

2.8 Convector Gauge Specifications

Pressure Range	1 x 10 ⁻⁴ Torr to 990 Torr, N ₂ equivalent
Display Resolution	3 significant digits, except for 1 significant digit in 10 ⁻⁴ Torr digit range
Gas Type	N ₂ , Air
Display Update Time	0.5 sec typical. Switch selectable to 3 sec/reading, averaged
Analog Output	Logarithmic, 1V/decade, Factory set to 0 -7 Vdc. Adjustable offset +1 Vdc to -7 Vdc. 10 mA maximum current
Maximum Temperature Range	+150 °C
Gauge Operating Temperature	+150 °C to +50 °C

Display Resolution

Range			Resolution
Torr			
0.1 x 10 ⁻³	to	99.9 x 10 ⁻³	0.1 x 10 ⁻³
100 x 10 ⁻³	to	999 x 10 ⁻³	1.0 x 10 ⁻³
1.00	to	9.99	0.01
10.0	to	99.9	0.1
100	to	999	1
mbar			
0.1 x 10 ⁻³	to	99.9 x 10 ⁻³	0.1 x 10 ⁻³
100 x 10 ⁻³	to	999 x 10 ⁻³	1.0 x 10 ⁻³
1.00	to	9.99	0.01
10.0	to	99.9	0.1
100	to	999	1
1.00 x 10 ⁺³	to	1.33 x 10 ⁺³	10
pascal			
10 x 10 ⁻³	to	9.99	0.01
10.0	to	99.9	0.1
100	to	.999 x 10 ⁺³	0.001 x 10 ⁺³
1.00 x 10 ⁺³	to	9.99 x 10 ⁺³	0.01 x 10 ⁺³
10.0 x 10 ⁺³	to	99.9 x 10 ⁺³	0.1 x 10 ⁺³
100 x 10 ⁺³	to	133 x 10 ⁺³	1 x 10 ⁺³

Chapter 3 - The Thermocouple Gauge Module

3.1 Introduction

The Thermocouple Gauge (TC) Module for the Granville-Phillips 316 Vacuum Gauge Controller provides pressure measurement from 1×10^{-3} Torr (1×10^{-3} mbar or 1×10^{-1} Pa) to 1 Torr. The basic 316505, 316506, 316507, or 316508 VGC displays pressure from one thermocouple gauge in display "A" via the single channel "A", thermocouple module. Two additional pressures from thermocouple gauges can be displayed in lines "B" and "C" via the dual channel "B" and "C" module. These gauges, modules and displays are designated "TCA", "TCB" and "TCC" in this manual. Analog output is also provided. When used with the process control, TCA controls setpoints 1 and 2, TCB controls setpoints 3 and 4, and TCC controls setpoints 5 and 6.

3.2 Thermocouple Gauge Module Installation

3.2.1 Units of Measure

Your instrument was shipped from the factory preset to display the units of measure - Torr, millibar or pascal, that you requested. If you want to change the displayed units, proceed as follows:

1. Remove power to the control unit.
2. Remove the top cover and locate the TCA thermocouple gauge PC board. See Figure 3-1.
3. Locate the millibar (#1), and the pascal (#2) units switches.
4. Leave both switches open for Torr units; close the appropriate switch for either millibar or pascal units.
5. Modify the units of measure of the TCB and TCC module to be consistent with the TCA gauge module.
6. Slip the label card out of the top of the front panel and apply the appropriate pressure units label.

Note: The Slow Update Switch is a display update rate switch. "ON" enables pressure averaging, and the display will update approximately every 3 seconds.

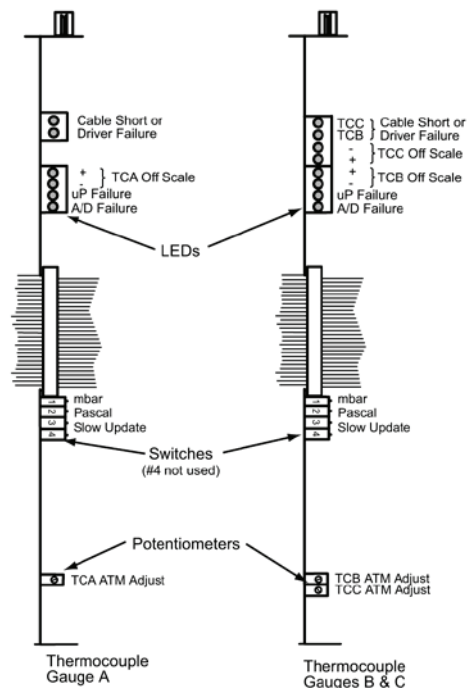

Figure 3-1 Thermocouple Modules, Top View (Controller Cover Removed)

3.3 Thermocouple Gauge Tube Installation

The 316 VGC thermocouple gauge module is designed to operate with Granville-Phillips 270006 or comparable transducers. (See section 3.8 for other compatible transducers).

The thermocouple gauge tubes can be installed anywhere in the system using a 1/8 NPT or .410 in. compression connection, or can be welded directly. Do not use compression fittings for positive pressure applications. If installed in any area where condensable vapors are present, mount with the open end pointing down to allow drainage.

3.4 Thermocouple Gauge Operation

3.4.1 Reading Pressure

The basic 316 VGC with thermocouples displays pressure from one thermocouple gauge in display A and two additional thermocouple pressures can be shown in displays B and C. Since thermocouple gauges have negligible resolution at pressures above 1 Torr, the instrument overflows to a pressure of 9.99 +9 at pressures above 1 Torr. If the gauge is reading "above atmosphere" the display will read 999 +9, that is, the decimal point disappears. This can be used in the atmosphere calibration procedure (see Section 3.5).

3.4.2 Analog Output

On the rear panel are provided analog outputs for both gauges. See Figures 3-2 and 3-3. The voltage is 0 to 10 Vdc, non-linear. Standard 1/8" miniature phone jack connectors are provided for the analog output.

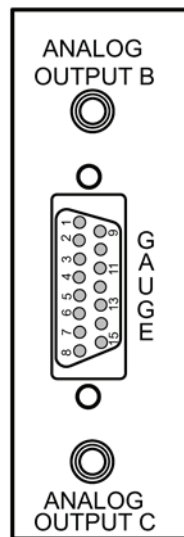

Figure 3-2 Thermocouple Gauge Module, Rear Panel

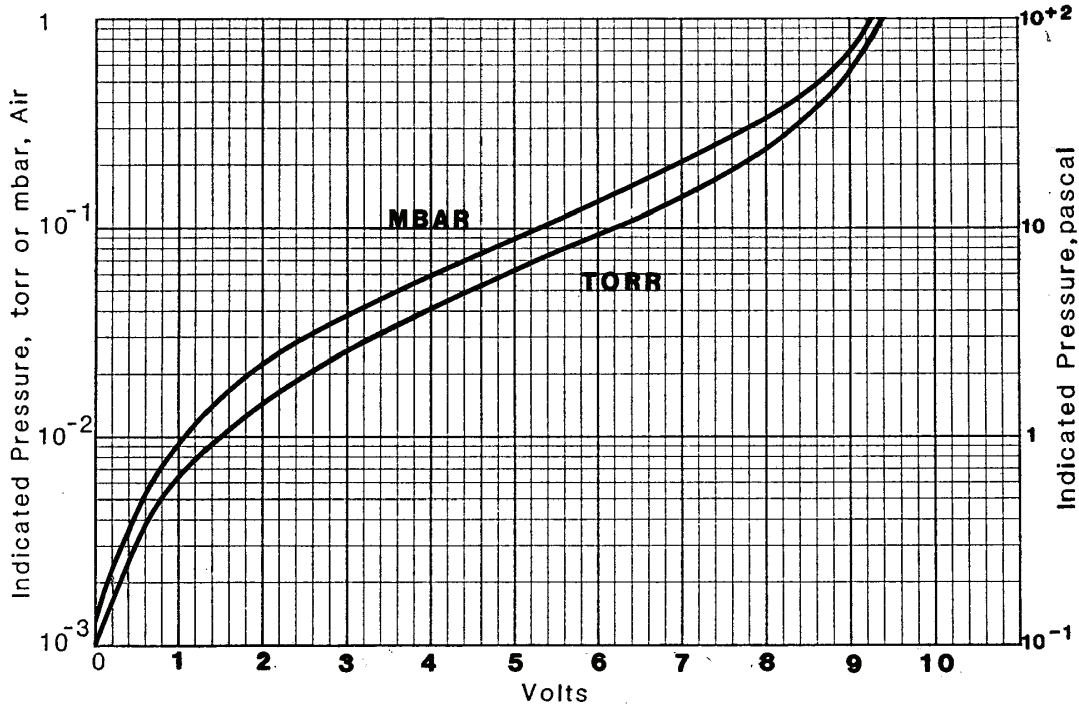

Figure 3-3 Thermocouple Gauge Pressure Analog Output

3.5 Thermocouple Gauge Calibration

3.5.1 Zero Adjustment (VAC)

1. Evacuate the system to a pressure less than 1×10^{-3} Torr.
2. With the gauge tube operating, adjust the VAC potentiometer until "0 0" shows in the display. Note that if the adjustment is turned too far below zero, a minus sign ("0 -0") will appear in the display. Thus proper zero calibration is achieved when only the "0 0" appears.

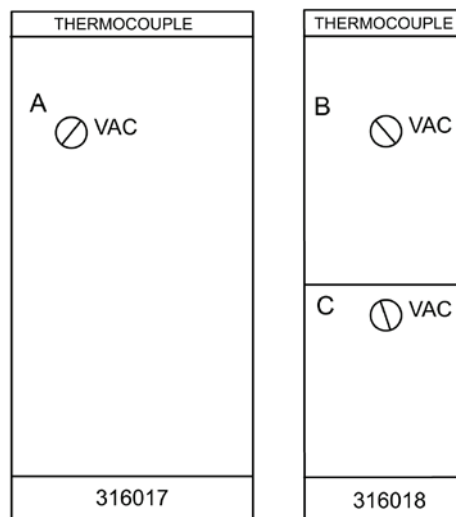

Figure 3-4 Thermocouple Gauge Modules, Front Panel

3.5.2 Atmosphere Adjustment (ATM)

Calibration at atmosphere is performed at the factory and should not normally be attempted by the user. However, the following procedure can be used to recalibrate the Atmosphere pressure reading.

1. Allow the system pressure to rise to atmospheric pressure.
2. Remove the top of the control unit.
3. Adjust the atmosphere potentiometer(s) (see Figure 3-5) for the thermocouple gauge(s), until the pressure display is $9.99 \times 10^{+9}$. Note that when adjusted beyond this point the decimal point of the display will disappear. "Perfect" calibration is achieved when the decimal point just disappears. The resolution of the gauge at this point is very poor, and the appearance or disappearance of the decimal point during normal operation when the gauge is at atmosphere is no cause for concern.

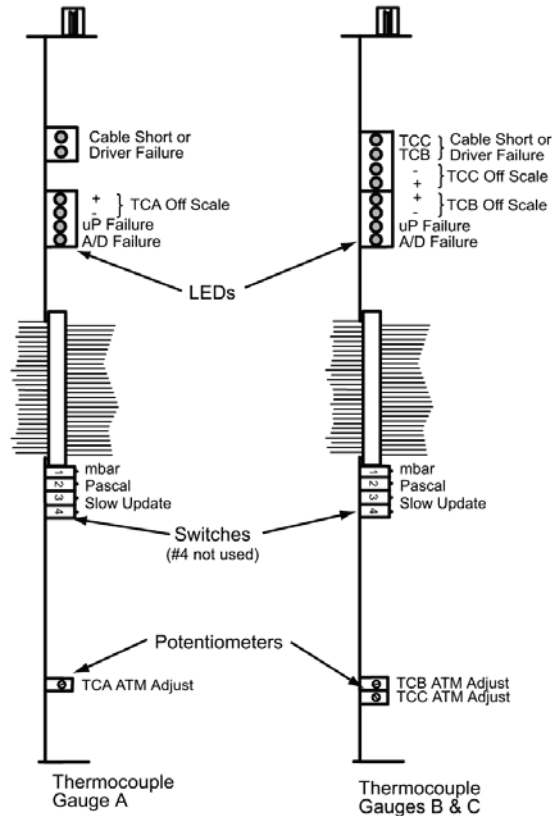

Figure 3-5 Thermocouple Gauge Modules, Top View (Controller Cover Removed)

3.6 Theory of Operation

The thermocouple gauge is a heat loss transducer. A constant AC voltage is applied to the sensor wire causing the wire to heat up. Molecules in the surrounding gas conduct heat from the wire so that at some constant concentration of molecules a particular temperature is achieved at the sensor. As the concentration of gas molecules impinging on the wire decreases, that is the pressure decreases, the temperature of the wire must increase. A wire of metal dissimilar from the sensor wire metal is attached to the sensor. The junction of the dissimilar metals causes a voltage to be generated which is non-linearly dependent upon the temperature of the junction. The 316 VGC measures this voltage and calculates the corresponding pressure in the gauge. Sources of error in the thermocouple gauge include: contamination of the sensor wire, calibration error at vacuum, and unknown gas composition.

3.7 Thermocouple Gauge Troubleshooting

3.7.1 Troubleshooting Guide

Refer to Figure 3-5 for the location of the LEDs listed in this guide.

Symptom	Possible Cause
Cable Short LED is illuminated	Cable has an electrical short or there is a circuit failure
Driver Failure LED is illuminated	Cable has an electrical short or there is a circuit failure
OFF Scale (+ or -) LED is illuminated	Circuit failure or TC gauge is out of calibration
µP Failure LED is illuminated	Microprocessor failure
A/D Failure LED is illuminated	A/D converter circuit failure
Display reads 9.99 +9	Thermocouple gauge is unplugged
Pressure reading very inaccurate	Tube contaminated or the Controller is out of calibration.
Tube reads at or below zero, or above atmosphere at all times	Controller out of calibration

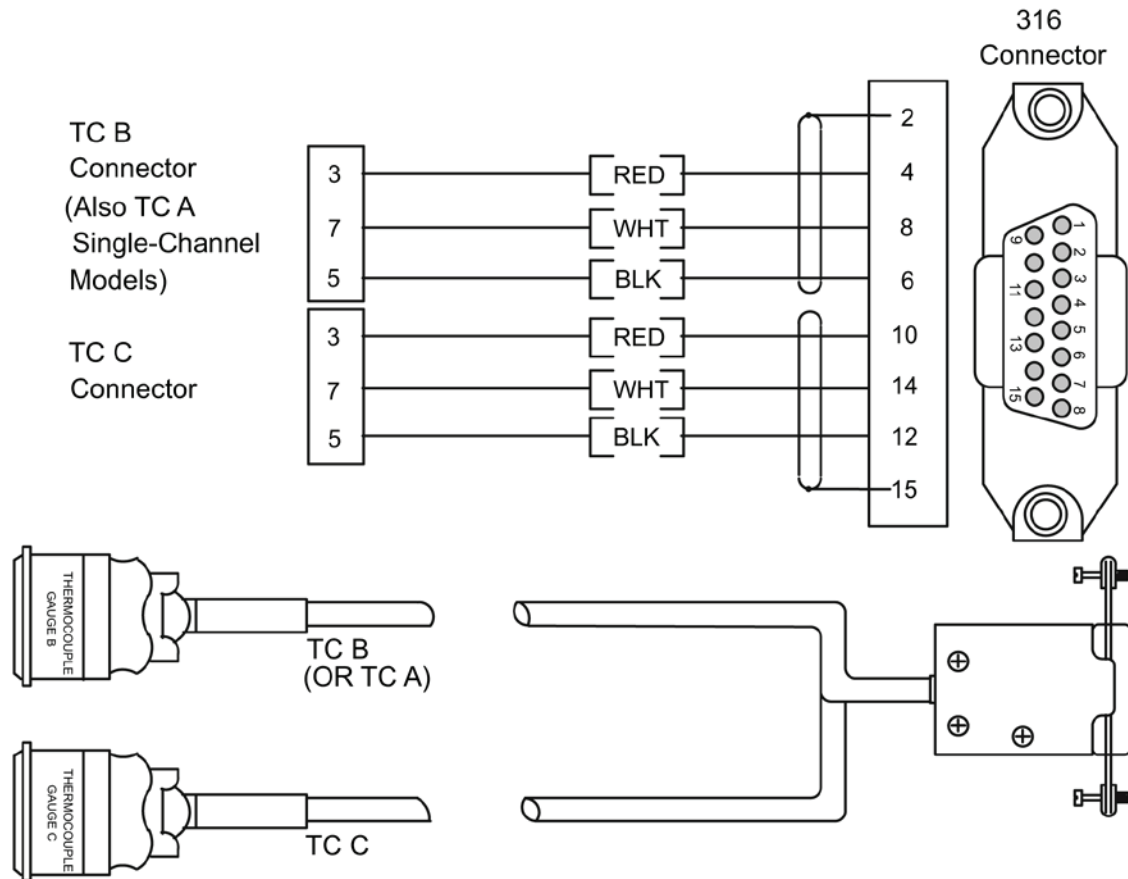

Figure 3-6 Thermocouple Gauge Cable Wiring

3.8 Thermocouple Gauge Specifications

Gauge Type	G-P 270006, Teledyne-Hastings DV-6M, DV-6R, DV-20 or equivalent
Pressure Range	1×10^{-3} Torr to 1 Torr, N ₂ or Air equivalent
Display Resolution	2 significant digits
Gas Type	N ₂ , Air
Display Update Time	0.5 sec typical. Switch selectable to 3 sec/reading, averaged
Analog Output	
Voltage	0 to 10 V nonlinear
Maximum Current	10 mA

Display Resolution

Range			Resolution
Torr			
1×10^{-3}	to	99×10^{-3}	1×10^{-3}
100×10^{-3}	to	990×10^{-3}	10×10^{-3}
mbar			
1×10^{-3}	to	99×10^{-3}	1×10^{-3}
100×10^{-3}	to	990×10^{-3}	10×10^{-3}
1.0	to	1.4	0.1
pascal			
100×10^{-3}	to	990×10^{-3}	10×10^{-3}
10	to	99	1
100	to	140	10

Chapter 4 - The Capacitance Manometer Module

4.1 Introduction

The Capacitance Manometer module allows pressure measurement from 1.0×10^{-4} Torr to 1000 Torr, depending on transducer pressure range. Up to 250 mA of current at ± 15 Vdc is supplied to temperature-compensated transducers. See the Specifications at the end of this chapter for a partial list of compatible transducers.

The module also operates one Convectron gauge. Refer to Chapter 2 of this manual for information on the use of the Convectron gauge.

When a six channel process control module is installed, the capacitance manometer can be used to control the two channels associated with display line "C", channels 5 and 6. The associated "B" Convectron gauge controls channels 3 and 4.

Analog output is provided for both gauges; the output is linear with pressure for the manometer, and logarithmic for the Convectron.

4.2 Installation

Units of Measure

The 316 VGC is shipped from the factory preset to display the unit of measure Torr, millibar, or pascal that you requested. If you want to change the measurement units, proceed as follows:

1. Shut off power to the control unit.
2. Remove the top cover. Locate the capacitance manometer PC board.
3. Locate the millibar and the pascal unit switches.
4. Leave both switches OFF for Torr units. Turn on the appropriate switch for millibar or pascal units.
5. Modify the units of measure of the "A" module to be consistent with the capacitance manometer module.
6. Slide the label card out of the top of the front panel and apply the appropriate pressure units label.

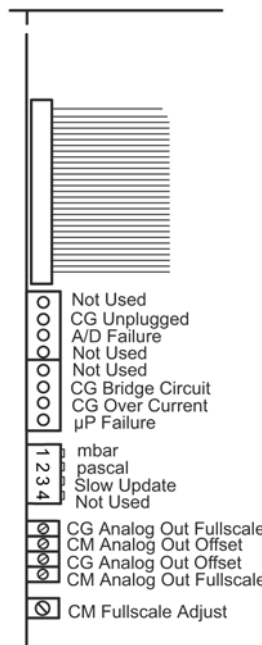

Figure 4-1 Capacitance Manometer Module, Top View (Controller Cover Removed)

Display Slow Update Rate Switch

When on this switch enables filtering which will stabilize a "jumpy" display. The display will update approximately every 3 seconds.

Convectron Gauge Controls

See Chapter 2 for information on use of Convectron controls.

Capacitance Manometer Vacuum Calibration

See Section 4.5.

Capacitance Manometer Range Switch

Your capacitance manometer transducer has a maximum pressure indication of 1, 10, 100, or 1000 Torr. Set this switch accordingly.

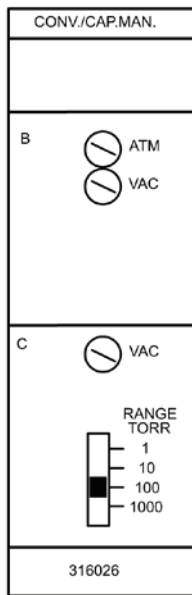

Figure 4-2 Capacitance Manometer Module, Front Panel

4.3 Capacitance Manometer Cable Installation

The cable supplied by Granville-Phillips for this module connects to both a Convectron gauge and a capacitance manometer. Since electrical connectors to capacitance manometers are not standardized, Granville-Phillips provides cables terminated with tinned wire leads. Figure 4.3 shows the color-coded functions of the wires. Refer to the manual for your capacitance manometer transducer for information on electrical connection, and installation of the transducer in your vacuum system.

The 316 VGC will display pressures from capacitance manometer transducers with 0 to 10 Vdc outputs and provide power to transducer requiring ± 15 Vdc inputs. The 316 VGC can also be used as a readout device for capacitance manometers which require 115 Vac power input such as the MKS 220B. To wire the 316 to such a transducer, connect the white (+ signal), and brown (signal ground) wires to the manometer as directed in the transducer instruction manual. Insulate the remaining red (+15 V), black (power ground) and blue (-15 V) wires at the manometer end of the 316 cable. Connect the transducer to a 115 Vac power source as directed in your instruction manual.

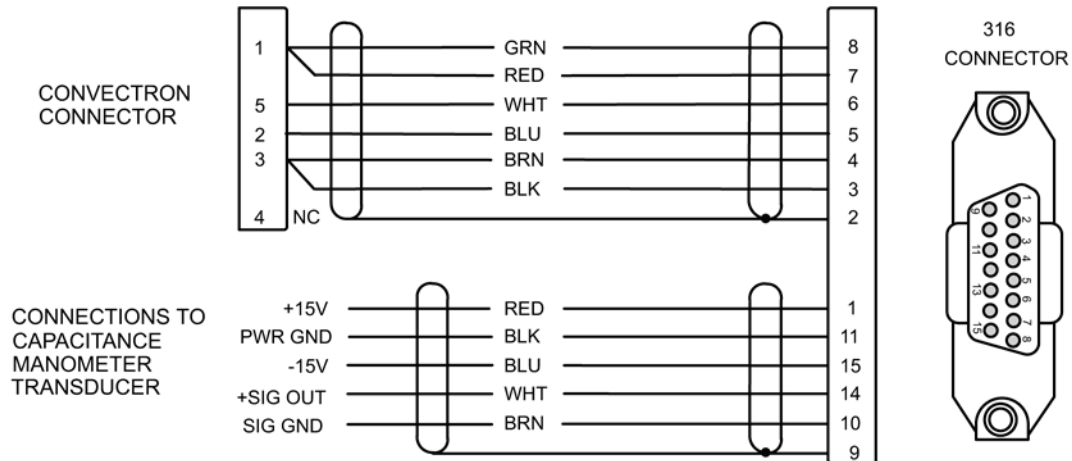

Figure 4-3 Capacitance Manometer Module, Cable

4.4 Operation

4.4.1 Reading Pressure

The capacitance manometer pressure is displayed in the third display line of the 316 controller. The accompanying Convectron gauge is displayed in the second display line. If the cable is disconnected, the manometer will read 0 pressure.

4.4.2 Analog Output

Analog outputs are provided on the rear panel for both the Convectron gauge and capacitance manometer. Standard 1/8 inch miniature phone jack connectors are provided for the analog output. The analog output for the capacitance manometer is a dc voltage proportional to the transducer output with a range of 0 to 10 volts. Refer to the documentation for your transducer for a description of this output.

Internal adjustments are provided for zero offset and full-scale (gain) control. See the Calibration section of this chapter for adjustment.

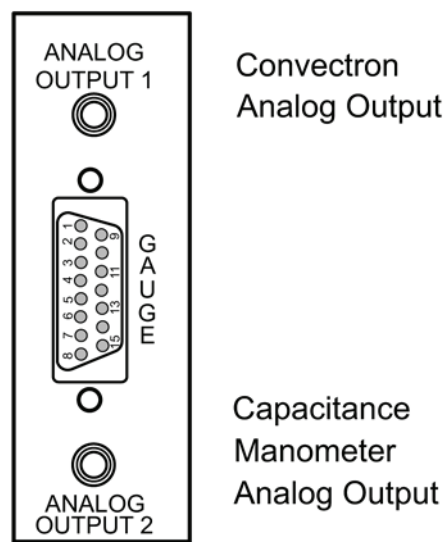

Figure 4-4 Capacitance Manometer Module, Rear Panel

4.5 Calibration

4.5.1 Initial Transducer Calibration

When first installed, your transducer zero-adjust should be set using a voltmeter to read zero when system pressure is below the minimum pressure range of the transducer. Refer to the documentation accompanying your capacitance manometer transducer for instructions on this procedure. You should also, at this time, adjust the VAC on the 316 controller with the gauge not attached to the controller, per the instructions below. After this initial setup has been performed, the routine fine-tuning of the transducer zero may be performed with the module front panel zero adjust potentiometer. The zero can be adjusted to -200 mV to +200 mV.

To Set The Controller Zero (Initial Controller Setup)

1. Disconnect the capacitance manometer cable either at the gauge head or at the controller.
2. Adjust the vacuum potentiometer until the third display line displays a single "0". If the adjustment is turned too far, a minus sign will appear in the display. Proper calibration is achieved when only the "0" appears.

To Zero The 316 VGC with the Transducer

1. Be sure the transducer was zeroed properly on initial installation; see your transducer documentation. Connect the cable from the 316 VGC to the capacitance manometer transducer. See Section 4.3 and Figure 4-3.
2. Evacuate the vacuum system to below the minimum rated pressure of your transducer.
3. Adjust the vacuum potentiometer (Figure 4-2) until the third display line shows a single "0". If the adjustment is turned too far, a minus sign will appear in the display. Proper calibration is achieved only when the "0" appears.

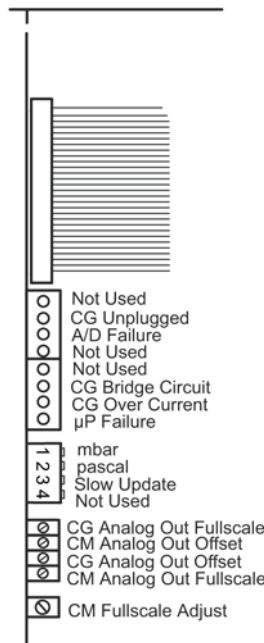

Figure 4-5 Capacitance Manometer Module, Top View (Controller Cover Removed)

4.5.2 Convectron Controls

See Chapter 2 of this manual.

4.5.3 Capacitance Manometer Analog Output Offset Adjust

This potentiometer is used to set analog output 2 at zero pressure. This value is also affected by the Vacuum Adjust potentiometer (Figure 4-2). The output can be adjusted to values between -0.2 and +0.2 volts at zero pressure.

4.5.4 Capacitance Manometer Analog Output Full-Scale Adjust

This is a span or gain control, with a range of 0.93 to 1.3. The factory setting is for a gain of 1.0, thus 10 volts in from the transducer (maximum readable pressure) = 10 volts out from the 316 at the factory setting.

4.5.5 Capacitance Manometer Full-Scale Adjust

This potentiometer controls the full-scale readout of the 316 capacitance manometer display. The control is adjusted at the factory for a full-scale display with an input of 10.0 volts. After zeroing the controller as described above, the 316 can be calibrated to the transducer by adjusting the Full-Scale Adjust potentiometer so the 316 display corresponds to the pressure of the manometer at or near the maximum pressure. This reference pressure can be determined by a certified standard gauge, a dead weight calibration system, or a standard voltage reference. The Full-Scale Adjust potentiometer and the CM Analog Out Full-Scale potentiometer do not interact and can be adjusted independently.

4.6 Theory of Operation

Within the capacitance manometer, a diaphragm is distorted by the pressure of the gas in the system under measurement. This diaphragm forms part of a capacitor, and its deflection causes changes in capacitance. Thus, the electrically measured capacitance is a measure of pressure. The device is very sensitive to the elastic properties of the metal of the diaphragm. For this reason, large pressure excursions, such as occur when the system is raised to atmospheric pressure, can cause offsets to the pressure reading. The diaphragm is also extremely sensitive to temperature effects, and although it may be held in a temperature-controlled chamber, this temperature control is never perfect, resulting in further perturbations to the devices theoretical accuracy.

Note that these perturbations are inherent in the capacitance manometer design, and are not a property of the electronic module used to operate the transducer.

Capacitance manometers are capable of exceptional accuracy, and read pressure independent of gas type, but are also subject to zero-point drift, and must be calibrated at vacuum frequently if high accuracy is to be obtained. Refer to the manual for your transducer for instructions.

4.7 Capacitance Manometer Troubleshooting

Refer to Figure 4-5 to locate LEDs on the capacitance manometer PC board.

Symptom	Possible Cause
Unstable reading	Mechanical vibration of capacitance manometer, faulty system ground or cable ground
Display always reads 0	Capacitance manometer cable unplugged or faulty cable No ± 15 V power
CG Unplugged LED is illuminated	Convectron gauge unplugged
A/D Failure LED is illuminated	A/D failure or defective A/D converter circuit
CG Bridge Circuit LED is illuminated	Defective PC board or Convectron bridge circuit
CG Over Current LED is illuminated	Convectron over current Defective gauge or cable
μ P Failure LED is illuminated	Microprocessor failure

4.8 Specifications

See Chapter 2 on the Convectron Gauge for additional specifications.

Gauge Type	Any capacitance manometer transducer that requires ± 15 Vdc power at ≤ 250 mA and outputs 0 - 10 Vdc proportional to pressure. These include but are not limited to: MKS Series 600 heads: (622A, 626A, 627A, 632A) Inficon: CDG025 Series
Accuracy	0.01% of full scale (as limited by display resolution).
Display Resolution	Highest 2 decades - 3 digits, next to lowest decade - 2 digits, lowest decade - 1 digit.
Pressure Range	1, 10, 100, 1000 Torr max heads, 4 decades of pressure.
Display Update Time	Unfiltered: 0.5 sec. typical. Switch selectable filtering: 3 sec. (average of 6 readings).
Output to Head	± 15 V $\pm 2\%$, 250 mA maximum.
Input from Head	0-10 Vdc into 100 K ohms.
Analog Output	0-10 Vdc, 5 mA maximum.
Analog Output Speed	Governed by transducer speed.
Cable Connection	Cable termination is bare tinned wire - user terminates to transducer.

Chapter 5 - The Process Control Module

5.1 Safety Notices

Improper wiring, programming or operation of the process control module can result in equipment damage or personnel injury. To avoid these possibilities:

- Program the setpoints for fail-safe operation. Use setpoint pressure, gauge assignment and polarity setting to provide safe operation in the event of equipment or power failure.
- Label the setpoints on the 316 front panel to avoid confusion and allow safe manual operation.
- Verify system operation by manually stepping through the control sequence before switching to automatic control. Check that a malfunction in the sequence cannot produce a hazard.
- Install safety devices in the system to limit hazardous conditions. For example, a pressure relief device should be installed on any system using a high pressure gas source.
- Restrict manual operation of the process controls to only knowledgeable persons.

5.1 Introduction

A Process Control Module provides the 316 Vacuum Gauge Controller with single-pole, double-throw relays that can be controlled either by digital setpoints or by the built-in manual override switches.

The Process Control Module can be purchased with 2 or 6 channels. The first 2 channels are assigned to the CGA or TCA. If present, channels 3 and 4 are assigned to CGB or TCB; and channels 5 and 6 to CGC, TCC, or CMC.

All six channels have selectable polarity for activation above or below the setpoint.

5.2 Process Control Module Installation

5.2.1 Process Control System Connections

Prior to connecting the process controls to the system, it is recommended that the following steps be followed. If application assistance is desired, contact a Brooks Automation, Inc. Customer Service Representative.

1. Develop a logic diagram of the process control function.
2. Prepare a specification table which lists the proposed pressure setting, system measurement point, and polarity for each PC channel.
3. Draw a circuit schematic which specifies exactly how each piece of system hardware will be connected to the 316 process control relays.
4. With the Process Control Module connector disconnected from the controller and power disconnected, connect the process control cable to the devices to be controlled.
5. Ensure that all devices are under manual control before connecting to the Process Control Module.
6. Attach a copy of the process control circuit diagram to this manual for future reference and troubleshooting.

The process control connector is embossed with letters identifying each pin. The following table shows the letters designating the 3 pins assigned to each of the 6 channels.

Channel	1	2	3	4	5	6
Pole	W	H	M	C	J	S
N. C.	P	A	U	K	B	X
N. O.	T	D	R	F	E	V
Pin L: Chassis Gnd. / Pin N: No Connection						

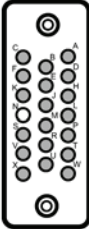

Figure 5-1 Pin Assignments/Connector

5.3 Process Control Operation

At all times the status of the 6 relays are displayed in the relay status LEDs on the 316 front panel. The LEDs do not indicate whether the gauge pressure is above or below the programmed setpoint, since setpoint polarity and manual override status can result in activation above or below the setpoint.

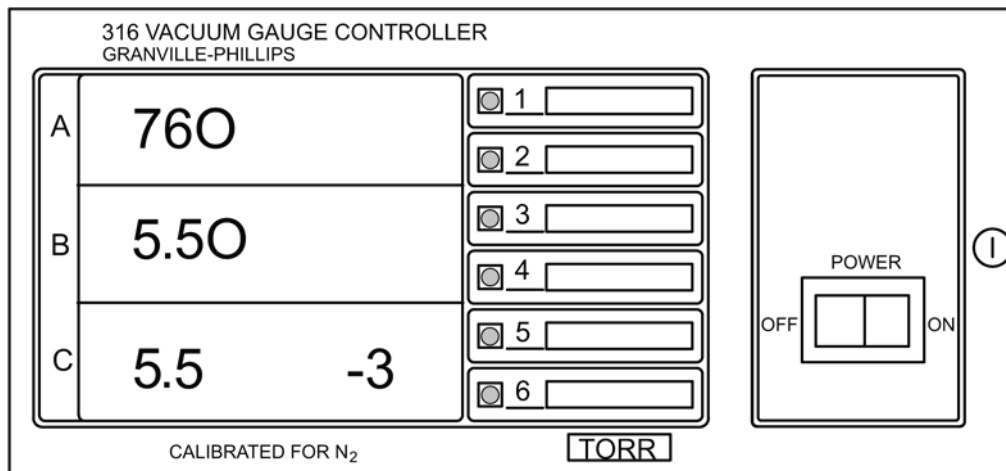

Figure 5-2 Process Control Relay Status Lights

5.3.1 Setpoint Display and Adjustment

Setpoints are stored in non-volatile memory, and are specified by a 1-digit mantissa and 1-digit exponent. They can be set anywhere in the range 1×10^{-5} to $9 \times 10^{+5}$. This allows for the entire pressure range of all supported transducer types and systems of units. The setpoint is displayed in scientific notation.

The setpoint is compared directly to the display data, so units of measure are implicit. Changing the units switch on the gauge control modules will not change the stored setpoints. They must be re-programmed in the new system of units.

If a setpoint is set to "above atmosphere", the relay will always be activated (unless its polarity is reversed, see "Relay Polarity Setting" in this section), except during overflow conditions that occur, e.g. when a Convectron gauge is disconnected. If it is desired that a process control be held in one state, the manual override switch should be used. If the setpoint is adjusted below 1×10^{-5} to 0, it will always be deactivated (unless polarity is reversed).

To Display a Setpoint

Refer to Figure 5-3 when displaying setpoints.

1. Rotate the Channel Selector thumbwheel to the number of the channel you want to display.
2. Press the Up or the Down SET button and release. The programmed setpoint will appear for 2 seconds in the same display line as the associated transducer:
 - Setpoints 1 and 2 appear in display 1.
 - Setpoints 3 and 4 appear in display 2.
 - Setpoints 5 and 6 appear in display 3.

To Modify a Setpoint

Refer to Figure 5-3 when modifying setpoints.

1. Rotate the Channel Selector thumbwheel to the number of the channel you want to modify.
2. Press and hold the Up or Down SET button for the direction you want the setpoint to change; up to raise the setpoint, or down to lower the setpoint.
3. The setpoint will scroll until the button is released. It will scroll slowly until a decade boundary is crossed and then will speed up to facilitate rapid changes across many decades. Release the button when you have entered the desired decade, and then re-depress it to scroll slowly within the decade to reach the exact setpoint needed.

After the setpoint button is released, the display will return to pressure data after two seconds. At this time the new setpoint will be deposited in non-volatile memory.

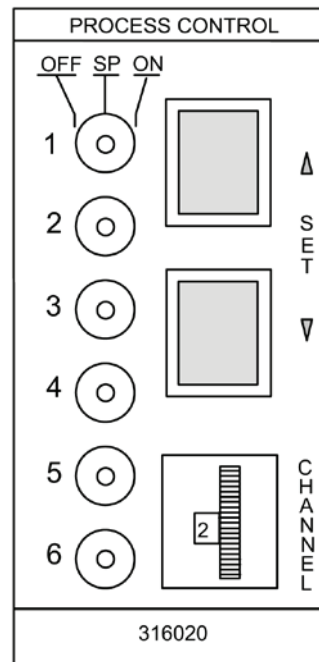

Figure 5-3 Process Control Module, Front Panel

5.3.2 Points to Consider in Using the Process Control Module

If neither the CONVECTRON B and C nor the Thermocouple B and C Gauge Module is present, channels 3-6, if present, will always be deactivated.

While the setpoint pressure is being displayed or changed via the up or down pushbuttons, the process control does not receive updated pressure information for the gauge being displayed. The pressure value stored in Process Control memory is the value displayed when the pushbutton was pressed. If the setpoint is

scrolled through this stored pressure value, the relay will change state unless the manual override switch is in a manual operation position.

There is a programmed 10% hysteresis on each process control setpoint. For example, with a pressure setpoint of 6.3 Torr the relay will activate when the display reaches 6.2 Torr (for falling pressure) and will deactivate when the pressure rises to one significant digit above the setpoint plus 10%, i.e., $6.3 + 0.6 + 0.1$ or 7 Torr. For setpoints where the 2nd digit is 0.5 or greater the 10% value is rounded up. For example, if the setpoint is programmed to 6.6 Torr the relay will activate at 6.5 Torr (on falling pressure) and will deactivate when the pressure rises to $6.6 + 0.7 + 0.1$ or 7.4 Torr.

Since the process control and computer interface modules derive their pressure data directly from the display bus, they will be unable to update their pressure data while setpoints are being displayed. They will not mistakenly interpret setpoint data as pressure data, but will simply retain the last displayed pressure data until the SET key is released.

If the thumbwheel setting is changed while a setpoint is being displayed, this change will not take effect until the display has been released and the SET key depressed another time.

Relay Polarity Setting

The relays can be set to activate with pressure either above or below the setpoint. A switch is provided for each channel. For activation below the setpoint, the switch should be in the OFF position. This is the factory setting.

Refer to the numbers on the printed circuit board, not on the switch body itself, for the channel number.

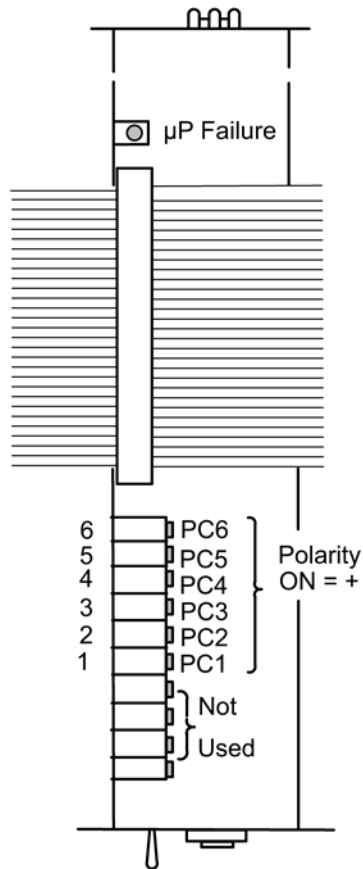

Figure 5-4 Process Control Module, Top View (Controller Cover Removed)

5.3.3 Manual Override

The six three-position switches on the front of the process control module allow override of the programmed setpoints at any time. When moved to the right, the relay is activated. When moved to the left, the relay is deactivated. When left in the center position, the relay is controlled automatically.

5.4 Process Control Theory of Operation

The process control module contains a dedicated microcontroller and a nonvolatile memory chip for storage of the setpoints. Since data is read/written to this chip serially, it is necessary to store working copies of the setpoints in internal RAM memory.

The microcontroller compares the setpoints with the pressure display data on the display bus and makes a decision as to whether or not to activate a channel's relay. The manual override switches, when set to ON or OFF position, take precedence over the microcontroller's decision.

5.5 Process Control Troubleshooting

The setpoints are read from non-volatile memory into RAM when the unit powers up. If a setpoint is found to contain data which cannot be interpreted as a valid setpoint, it will be set to 0.

If Microprocessor LED (Figure 4-4) is illuminated or flashing, there is a circuit failure.

5.6 Process Control Specifications

Number of channels	2 or 6
Pressure range	1.0×10^{-5} to $9.9 \times 10^{+5}$. Setpoints are compared directly to display data and must be reprogrammed if the measurement units, Torr, mbar, or pascal, are changed.
Hysteresis	Approximately 10%
Setpoint adjustment	Digital, 2 significant digits plus exponent, scientific notation
Output relays	
Contact rating	5 A at 250 Vac resistive or 30 Vdc
Contact style	SPDT
Polarity	Switch selectable for activation with pressure above or below the setpoint. The factory setting is for activation below the setpoint.

Chapter 6 - The RS-232 Module

6.1 Introduction

The RS-232 Interface Module for the 316 Vacuum Gauge Controller allows data output to a host computer. Output is either by a command-response mechanism or by a talk-only mode which is invoked via a switch on the RS-232 PC board.

A variety of baud rates and byte framing options are available, as well as switches to force the handshake lines to an "always true" condition.

6.2 RS-232 Installation

All DIP switches on the RS-232 module are read by the microprocessor only during the power-up sequence. To change any of the switch functions you must change the switch setting then cycle the power to the 316 controller. When the switch is in the OFF position, the switch is away from the PC board.

The interface protocol is set using 8 switches as illustrated in the tables below, and Figure 6-1. Switch S1 is the Talk Only switch, shown at the top of the illustration. When shipped from the factory, the interface is set at 9600 baud, 8 character bits, 2 stop bits, no parity bit, DCD, CTS and DSR forced "true", and Talk-Only mode disabled.

6.2.1 Selecting the Byte Format

6.2.2 Baud Rate

Dip switches 6, 7, and 8 are used to control the baud rate.

S6	S7	S8	Baud Rate
On	On	On	9600 (default)
On	On	Off	4800
On	Off	On	2400
On	Off	Off	1200
Off	On	On	600
Off	On	Off	300
Off	Off	On	150
Off	Off	Off	75

6.2.3 Character Framing

Switches 3, 4, and 5 control parity, number of character and stop bits:

S3	S4	S5	Character Bits	Parity	Stop Bits
On	On	On	8	None	2 (default)
On	On	Off	8	Even	1
On	Off	On	8	Odd	1
On	Off	Off	7	None	2
Off	On	On	7	Even	1
Off	On	Off	7	Odd	1
Off	Off	On	7	Even	2
Off	Off	Off	7	Odd	2

6.2.4 Talk-Only Mode

If switch S1, is OFF at power-up, the interface is in Talk-Only mode. The pressure data from all three displays will be output in a single message string, separated by commas, approximately every 5 seconds. When shipped from the factory, the Talk-Only mode is disabled.

6.2.5 Handshake Line Control Switches

Refer to Section 6.4, Theory of Operation for more detailed information on the handshaking mechanism.

Switches DCD, CTS, and DSR, when in the "up" position, force the handshake lines Data-Carrier-Detect (DCD), Clear-To-Send (CTS), and Data-Set-Ready (DSR), respectively, to a logic true condition. When shipped from the factory, these lines are forced true.

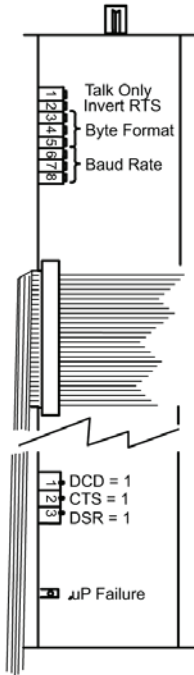

Figure 6-1 RS-232 Module, Top View (Controller Cover Removed)

6.2.6 Invert RTS Switch

When shipped from the factory, the Request-To-Send (RTS) control line is set to operate as a modem line per the RS-232 standard. In some implementations it is necessary to invert this line and connect it directly to the Clear-To-Send (CTS) line of the host computer.

Switch S2, if OFF when the 316 goes through its power-up sequence, tells the RS-232 interface to invert the polarity of the RTS line. See Section 6.4, Theory of Operation for more information.

6.3 Operation

Consult the user's manual for the host computer to be sure the protocol being used is in accordance with the switch configuration you have chosen for the RS-232 module.

Communication with the 316 VGC is via ASCII strings. A message to the 316 consists of a command and a command modifier, followed by a terminator. The message can contain leading spaces, and the command and modifier may optionally be separated by spaces or commas. No spaces may appear within the command or the modifier, only between them.

The terminator expected by the 316 is an ASCII 'carriage return line feed', denoted here by CRLF. The carriage return is optional, and messages terminated with only the line-feed will be accepted. Note that the CRLF terminator is in general appended automatically by the host computer's interface software to the message string supplied by the user.

If extra characters are found in the message after it has been successfully interpreted, but before the terminator, they will be ignored. All characters should be upper case. All messages to the 316 will receive a reply, consisting of an ASCII string terminated with CRLF. Numbers will be returned in the format X.XXE±XX.

6.3.1 Command Syntax

DS

Definition: Display pressure reading
Modifiers: CG1 or CG2 or CG3 or 1 or 2 or 3
Response: ASCII string representing the pressure for the selected gauge
Example: From computer: DS CG1 CRLF
From 316: 1.20E-03CRLF

NOTES

1. The **DS CG1**, **DS CG2** and **DS CG3** commands or **DS1**, **DS2**, and **DS3** commands, are used to display the pressures from the A, B and C display lines, respectively, with either the Convectron, Thermocouple, or Capacitance Manometer Gauge Module installed.
2. If data is requested from a Convectron, Thermocouple, or Capacitance Manometer Gauge when none is installed, the 316 will return **9.99E+09**.

PCS

Definition: Display process control channel status.
Modifiers: **1** or **2** or **3** or **4** or **5** or **6** or **B** or none.
Response: Depends on modifier:
Modifier = single digit (1 through 6); response = single ASCII digit, **0** if the corresponding relay is inactive, **1** if active.
Modifier = **B** response = a byte of data with bits 0 through 5 set/clear according to whether the corresponding relay is active/inactive. Bit 6 will always be set to guarantee that the returned byte will not appear as a terminator byte.
Modifier absent response will be a string of 6 ASCII 0's and 1's separated by commas giving the status of all six channels.

Examples: Assume that channels 1 - 3 are active, and 4 - 6 are inactive.

From computer: **PCS 1 CRLF**

From 316: **1CRLF**

From computer: **PCS B CRLF**

From 316: **G CRLF**

The ASCII "G" corresponds to the bit pattern 01000111 and represents the status of the PC channels in bit 0 through 5.

From computer: **PCS CRLF**

From 316: **1,1,1,0,0,CRLF**

Error Messages

If an error is found in the incoming message, the following messages will be returned in place of the normal response:

OVERRUN ERROR - Returned if the incoming message overflows the 316's buffer. This can indicate a flaw in the host software.

PARITY ERROR - Returned if the parity of a byte in the incoming message does not match that programmed by the switches. This can indicate the presence of electrical noise on the transmission line.

SYNTAX ERROR - Returned if the message fails to parse as a valid 316 command. Could also result from failure to assert DCD during transmission to the 316.

6.4 RS-232 Theory of Operation

Handshaking

The RS-232 interface implements the following signals:

SIGNAL	PIN #	DIRECTION
Protective Ground	1	-
Transmitted Data	2	To Computer
Received Data	3	To 316
Request to Send (RTS)	4	To Computer
Clear to Send (CTS)	5	To 316
Data Set Ready (DSR)	6	To 316
Signal Ground (common return)	7	-
Data Carrier Detect (DCD)	8	To 316
Data Terminal Ready (DTR)	20	To Computer

The DTR line is set true by the 316 on power up to indicate it is on line. When the 316 receives a start bit on the received data line it will input and buffer a character. The DCD line must be true at the time each character is received or that character will be ignored. The 316 will continue to receive and buffer characters until the terminator (LF) is received.

Upon receiving the terminator, the 316 will assert the RTS line as a holdoff to prevent the host computer from attempting to transmit further data until the message just received is parsed and a reply is output.

During output of the reply, the incoming handshake lines CTS, and DSR are tested prior to beginning transmission of each character. The 316 will wait until both are true before beginning transmission of a character, and will not test them again until ready to begin transmitting the next.

After transmitting the terminator, the 316 will negate RTS and wait for the next incoming message.

To summarize:

CTS, DSR

Set by the computer to indicate that the 316 can output the next byte in its message. When shipped from the factory these lines are forced "TRUE" by the switch settings of the RS-232 printed circuit board, thus the 316 will automatically assume the host is ready to receive. See Figure 6-1 or 6-2 for the location of the switches.

DCD

Tested by the 316 when a character is received. The character will be ignored unless DCD is "TRUE". When shipped from the factory this line is forced "TRUE" by the switch settings.

DTR

Always asserted by the 316. A "power on" indication.

RTS

Negated by the 316 on power-up. Asserted by the 316 upon receipt of a message terminator. Negated after transmitting the terminator of the 316's response to that message.

Reversing the Polarity of RTS

If switch 2, Invert RTS, is off at power-up, the 316 will apply the opposite polarity to RTS from that described above. When used in this mode, RTS can be connected to the CTS input of the host computer. This violates the RS-232 standard, but is a commonly used implementation.

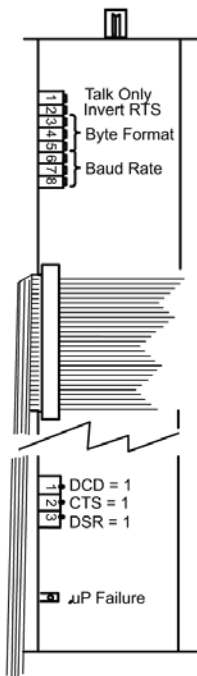

Figure 6-2 RS-232 Module, Top View (Controller Cover Removed)

6.5 RS-232 Troubleshooting

Because the RS-232 "standard" is found in a bewildering array of configurations, the first thing to do if trouble arises is check the following configuration options:

1. Check the switch settings.
Be sure baud rate, character format and framing, and interface protocol are matched to your host computer or terminal's requirements. Note that there can be several mismatched parameters. Check to see if your computer requires the reversed-polarity RTS convention.
2. Check the interface wiring.
The pin designations for the RS-232 connector are shown in Figure 6-2. Note that the "received" and "transmitted" data lines are defined as seen by the 316. Many companies supply "null modems" or switch boxes for the purpose of reconfiguring the control lines for particular applications.
3. Check the command format.
Be sure the strings you output to the 316 are in accord with the syntax defined in Section 6.3.

6.5.1 RS-232 Troubleshooting Guide

Symptom	Possible Cause
µP Failure LED is illuminated or flashing	Microcontroller failure
No response or garbled output	Baud rate incorrect, character length incorrect, or stop bit(s) incorrect
OVERRUN ERROR message	Stop bit(s) incorrect or host software failure
PARITY ERROR message	Parity incorrect or electrical noise on the transmission line
SYNTAX ERROR message	Message to the 316 is not in accord with the specified syntax or failure to assert DCD handshake line

6.6 RS-232 Specifications

Format	EIA standard RS-232 C, half duplex, asynchronous
Data Rates	75, 50, 300, 600, 1200, 2400, 4800, or 9600 baud
Character length	7 or 8 bit ASCII, switch selectable
Parity	Even, odd, or none, switch selectable
Stop bits	1 or 2. 8 character bits plus parity allows only 1 stop bit
Handshake	Outputs: DTR,RTS. RTS polarity selectable. Inputs: DSR, CTS, DCD. Can be forced to logic "TRUE" with switches
Logic levels	Inputs: Logic 1: 2.0 Vdc min.,15 Vdc max. Logic 0: -15 Vdc min.,0.75 Vdc max
Input Current:	4.0 mA max @ Vin = +15 Vdc -4.0 mA max @ Vin = -15 Vdc.

Chapter 7 - The IEEE 488 Module

7.1 Introduction

The IEEE 488 Module for the 316 Vacuum Gauge Controller allows data output to a host computer. Output is either by a command-response mechanism or by a talk-only mode which is invoked via a switch on the IEEE 488 board.

A switch is provided to configure the IEEE 488 bus to operate via SRQ interrupts which causes the 316 to generate an SRQ and wait for a serial poll before outputting each message.

7.2 IEEE 488 Installation

All DIP switches on the IEEE-488 module are read by the microprocessor only during the power-up sequence. To change any of the switch functions you must change the switch setting then cycle the power to the 316 controller.

7.2.1 Selecting the Interface Bus Address

Refer to Figure 7-1, switch No. 1. Each instrument on the IEEE 488 bus has an address from 0 to 31. The address is set at the factory to 8. The user must ensure that every device on his bus has a unique address. To select an address, switches 1 through 5 are adjusted according to binary weights.

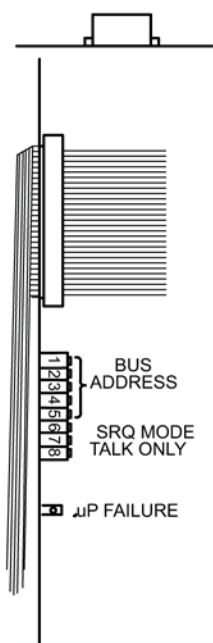

Figure 7-1 IEEE 488 Module, Top View (Controller Cover Removed)

Switch Number	5	4	3	2	1		
Value	16	8	4	2	1		
Setting Examples							
	ON	OFF	ON	ON	OFF	=	Address 9
	ON	ON	OFF	OFF	OFF	=	Address 7
	OFF	OFF	OFF	ON	ON	=	Address 28

Talk-Only Mode

Switch #8, if set to OFF at power-up, puts the interface in Talk-Only mode. The pressure data from all three displays will be output in a single message string, separated by commas, approximately every 5 seconds. When shipped from the factory, the Talk-Only mode is disabled.

SRQ Mode

Switch #7, if set to OFF at power-up, tells the interface to generate an SRQ interrupt and respond to a serial poll with a message output.

The serial poll response byte will contain a 1 in bit 6 (the second-highest bit). Bit 5 will be set if an error has occurred. In this case the pending message will be an error message. When shipped from the factory, SRQ mode is disabled.

7.3 IEEE 488 Operation

Communication with the 316 is via ASCII strings. A message to the 316 consists of a command and a command modifier, followed by a terminator. The message can contain leading spaces, and the command and modifier can optionally be separated by spaces or commas. No spaces may appear within the command or the modifier, only between them.

The terminator accepted by the 316 is an ASCII carriage return line feed, denoted here by CRLF. The carriage return is optional, and messages terminated with only the line feed will be accepted. Note that the CRLF terminator is in general appended automatically, by the host computer's interface software, to the message string supplied by the user.

A terminator is not required, if the last character of the message to the 316 VGC is accompanied by the EOI bus signal.

If extra characters are found in the message after it has been successfully interpreted but before the terminator, they will be ignored.

All characters should be upper-case.

All messages to the 316 will receive a reply consisting of an ASCII string terminated with CRLF, the LF being accompanied by EOI. Pressure data will be returned in scientific notation with the format X.XXE±XX.

7.3.1 Command Syntax

DS

Definition:	Display pressure reading.
Modifiers:	CG1 or CG2 or CG3 or 1 or 2 or 3.
Response:	ASCII string representing the pressure for the selected gauge.
Example:	From computer: DS CG1 CRLF From 316: 1.20E-03CRLF

NOTES

1. The DS CG1, DS CG2 and DS CG3 commands or DS1, DS2, and DS3 commands are used to display the pressures from the A, B and C display lines, respectively, with either the Convectron , Thermocouple, or Capacitance Manometer Gauge Module installed.
2. If data is requested from a Convectron , Thermocouple, or Capacitance Manometer Gauge when none is installed, the 316 will return 9.99E+09.

PCS

- Definition:** Display process control channel status.
- Modifiers:** 1 or 2 or 3 or 4 or 5 or 6 or B or none.
- Response:** Depends on modifier:
Modifier = single digit (1 through 6); response = single ASCII digit, 0 if the corresponding relay is inactive, 1 if active.
Modifier = B; response = a byte of data with bits 0 through 5 set/clear according to whether the corresponding relay is active/inactive. Bit 6 will always be set to guarantee that the returned byte will not appear as a terminator byte.
Modifier absent; response will be a string of 6 ASCII 0's and 1's separated by commas giving the status of all six channels.
- Examples:** Assume that channels 1 through 3 are active, and 4 through 6 are inactive:
From computer: PCS 1 CRLF
From 316: 1CRLF
From computer: PCS B CRLF
From 316: GCRLF
The ASCII "G" corresponds to the bit pattern 01000111 and represents the status of the PC channels in bits 0 through 5.
From computer: PCS CRLF
From 316: 1,1,1,0,0CRLF

Error Messages

If an error is found in the incoming message, one of the following messages will be returned in place of the normal response, and if the SRQ mode is used, bit 5 in the serial poll response byte will be set.

OVERRUN ERROR - Returned if the incoming message overflows 316's buffer.

SYNTAX ERROR - Returned if the message fails to parse as a valid 316 command.

7.4 IEEE 488 Troubleshooting

If your interface fails to function, first verify the following:

1. Check the switch settings
Be sure the controller knows the address of the 316 as set by the DIP switches. Be sure the system controller does not reserve certain addresses for system devices, e.g., a printer. Be sure the 316 is not in the talk-only mode unless desired for data logging. Be sure, if the SRQ mode is set, that your controller performs a serial poll in response to the SRQ from the 316 VGC.
2. Check the interface wiring
Be sure the cable is good. Substitute a known good cable (IEEE 488 cables are available from Granville-Phillips).
Check for too many devices on the bus or too great a total bus length (> 20 meters). Too many devices could cause problems due to capacitive loading.
3. Check the command syntax.
Be sure you are following the syntax specified in Section 7.3.

7.5 IEEE 488 Troubleshooting Guide

Symptom	Possible Cause
µP Failure LED is illuminated or flashing	Microcontroller failure.
OVERRUN ERROR message	Host software failure.
SYNTAX ERROR message	Message to 316 not in accord with specified syntax.

7.5 IEEE 488 Specifications

Capability codes: SH1, AH1, T5, L4, SR1, RL0, PP0, DC0, E1, OT0, C0

Chapter 8 - The RS-485 Module

8.1 Introduction

The RS-485 communications option for the Series 316 Vacuum Gauge Controller permits data output to a host computer using RS-485 digital communications. Communications handshake is by a command-response mechanism.

A variety of baud rates and byte framing options are available. The RS-485 byte format is configured to your system requirements using configuration switches located on the option board. These switches are accessed by removing the controller top chassis cover.

The RS-485 factory defaults are 9600 BAUD, 8 character bits, no parity, 1 stop bit, Address = 01

Internal switches are read upon power up. Changes in settings will take effect upon next power-up cycle.

8.2 RS-485 Installation

8.2.1 RS-485 Address

The address dial on the RS-485 module on the back of the controller and Switch S1 determine the controller's base RS-485 address. Switches S1.1 to S1.4 are used for Address offsets. This address can be any hex code from 00 to FF.

The address dial on the RS-485 module on the back of the controller determines the value of the least significant digit and the S1 switches determine the value of the most significant digit. The S1 switch positions are binary and the weight of each switch when OFF is given below.

To prevent data contentions, no two RS-485 nodes should be set with the same address. It is not recommended that address 00 be used because some manufacturers use this address for configuration.

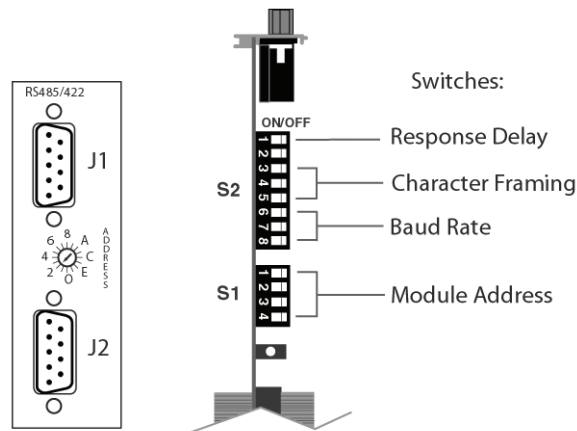

Figure 8-1 Back Panel and Top View of RS-485 Module

Switch Weight Setting when OFF

Switch	Weight
S1.1	10 Hex
S1.2	20 Hex
S1.3	40 Hex
S1.4	80 Hex

8.2.2 Response Delay for the RS-485 Interface

Switch S2.1 enables a delay of the response from the module of 10 to 13 MS + 10 bit times when OFF. When S2.1 is ON, the delay is greater than 700 microseconds. The factory default setting is ON, with a delay greater than 700 microseconds.

8.2.3 Selecting the Byte Format for RS-485 Communications

Baud rate for the RS-485 communications is determined by the settings of switches S2.6, S2.7 and S2.8. The factory default baud rate setting is 9600.

Baud Rate Switch Settings

S2.6	S2.7	S2.8	Baud Rate
ON*	ON*	OFF*	9600*
ON	OFF	ON	4800
ON	OFF	OFF	2400
OFF	ON	ON	1200
OFF	ON	OFF	600
OFF	OFF	ON	300
OFF	OFF	OFF	150

* = Factory Setting

8.2.4 Character Framing for the RS-485 Computer Interface

Character framing for the RS-485 computer interface is determined by setting switches S2.3, S2.4, and S2.5. The factory default setting is S2.3 On, S2.4 Off, and S2.5 Off - Character bits set to 8, Parity None, and Stop bits at 1.

Character Framing Switch Settings

S2.3	S2.4	S2.5	Character Bits	Parity	Stop Bits
ON	ON	ON	8	None	2
ON	ON	OFF	8	Even	1
ON	OFF	ON	8	Odd	1
ON	OFF	OFF	8*	None*	1*
OFF	ON	ON	7	Even	1
OFF	ON	OFF	7	Odd	1
OFF	OFF	ON	7	Even	2
OFF	OFF	OFF	7	Odd	2

* = Factory Setting

8.2.5 Connecting the RS-485 Computer Interface

Connectors J1 and J2 on the rear of the control unit are wired parallel and are interchangeable. Connection can be made by daisy chaining gauge controllers together with the signal from the host computer going into one connector, then out the other connector to another gauge controller.

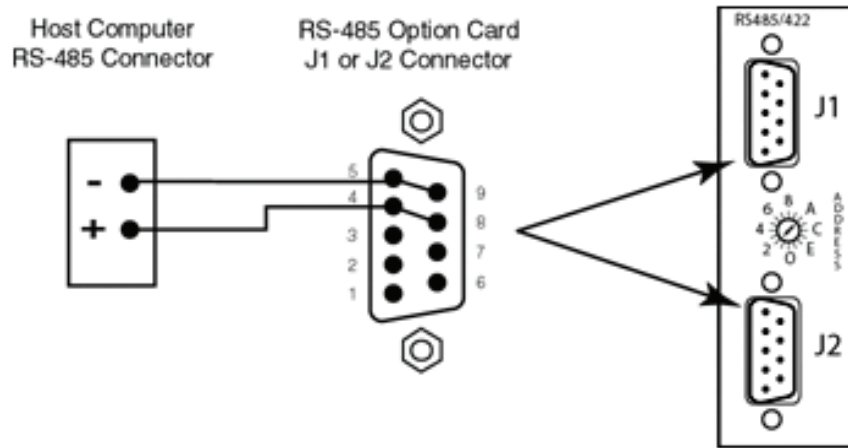

Figure 8-2 RS-485 Connectors

The maximum total cable length is 4,000 ft. No more than 32 devices can be connected to one RS-485 communications line. When an RS-485 network is in an idle state, all nodes are in listen (receive) mode. Under this condition there are no active drivers on the network. In order to maintain the proper idle voltage state, bias resistors must be applied to force the data lines to the idle condition. Figure 8-3 illustrates the placement of bias resistors on a host computer, 2-wire configuration, for the typical 5 volt and 24 volt systems.

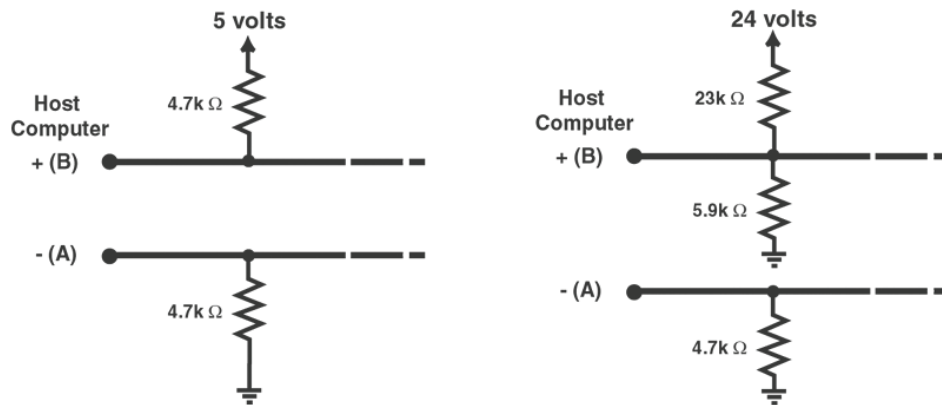

Figure 8-3 RS-485 Bias Resistors

In a four wire configuration connect TX on the gauge controller to RX on the host computer and connect RX on the gauge controller to TX on the host computer. If the computer sends and receives data on 2 wires, connect the RS-485+ from the computer to both the +TX and +RX Pins (Pins 4 and 8), and connect the RS-485- from the computer to both -TX to -RX (Pins 5 and 9).

When connecting multiple 316 Controllers, connect TX to TX and RX to RX on all controllers.

The polarity may have to be reversed on the computer and other instruments. You may have to try it both ways. No damage will result if connections are wrong.

8.2.6 Preparing for Use

The Series 307 Vacuum Gauge Controller uses a command-response half-duplex protocol. If the controller recognizes received data as a valid command, it will check the command string address and compare with its own. If the addresses match, the controller will process the command and then respond. In all configurations, only one twisted pair will have data transmissions in one direction at any time. The timing of the data transfer is shown in Figure 8-4. T0 is 10 to 13 mS + 10 bit times with S2.1 in the OFF position, T0 is greater than 700 microseconds with S2.1 in the ON position, and T1 is greater than 300 microseconds. Adhering to these timing constraints will ensure data is not overwritten.

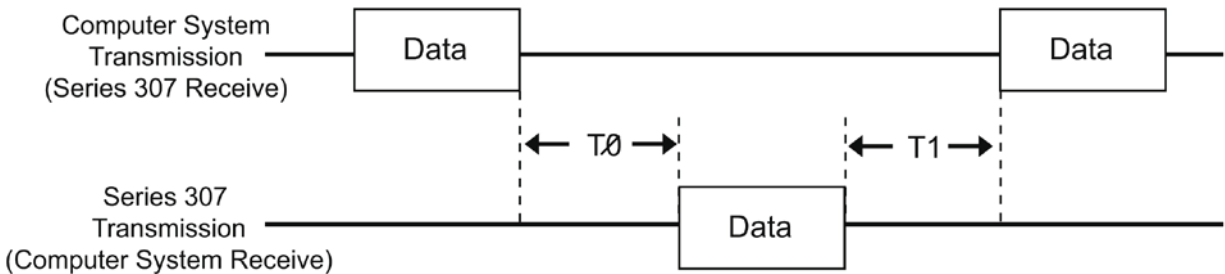

Figure 8-4 RS-485 Data Timing

Consult the user's manual for the host computer to be sure the character framing settings used are in accord with that established via the switch configuration you have chosen for the RS-485 module.

Communication is via ASCII strings. A message consists of a start character "#", an address "AA", command, and a command modifier, followed by a terminator. The message may contain leading spaces, and the command and modifier can optionally be separated by spaces. No spaces may appear within the command or the modifier, only between them.

The address expected is programmed via the switch settings on the rear of the module and the internal switch settings. (AA = 01 to FF Hex) The terminator expected is an ASCII carriage-return denoted here by CR. Note that the terminator is sometimes appended automatically, by the host computer's interface software, to the message string supplied by the user. If extra characters are found in the message after it has been successfully interpreted but before the terminator, they will be ignored.

All messages will receive a reply, consisting of an ASCII string terminated with CR. Pressure numbers will be returned in the format X.XXE±XX.

Messages may use upper or lower case alpha-numeric characters. The controller will always respond with upper case characters.

8.3 RS-485 Command Syntax

DS

Definition: Display pressure reading
Modifiers: CG1 or CG2 or CG3 or 1 or 2 or 3
Response: ASCII string representing the pressure for the selected gauge
Example: From computer: DS CG1 CRLF
From 316: 1.20E-03CRLF

NOTES

1. The **DS CG1**, **DS CG2** and **DS CG3** commands or **DS1**, **DS2**, and **DS3** commands, are used to display the pressures from the A, B and C display lines, respectively, with either the Convectron, Thermocouple, or Capacitance Manometer Gauge Module installed.
2. If data is requested from a Convectron gauge when none is installed, the 316 Controller will return 9.90E+09.

PCS

Definition: Display process control channel status.
Modifiers: 1 or 2 or 3 or 4 or 5 or 6 or B or none.
Response: Depends on modifier:
Modifier = single digit (1 through 6); response = single ASCII digit, 0 if the corresponding relay is inactive, 1 if active.
Modifier = B; response = a byte of data with bits 0 through 5 set/clear according to whether the corresponding relay is active/inactive. Bit 6 will always be set to guarantee that the returned byte will not appear as a terminator byte.
Modifier absent; response will be a string of 6 ASCII 0's and 1's separated by commas giving the status of all six channels.
Examples: Assume that channels 1 through 3 are active, and 4 through 6 are inactive:
From computer: PCS 1 CRLF
From 307 controller: 1CRLF
From computer: PCS B CRLF
From 307 controller: GCRLF
The ASCII "G" corresponds to the bit pattern 01000111 and represents the status of the PC channels in bits 0 through 5.
From computer: PCS CRLF
From 316 controller: 1,1,1,0,0,0 CRLF

Error Messages

If an error is found in the incoming message, the following messages will be returned in place of the normal response.

OVERRUN ERROR - Returned if the incoming message overflows the controller's buffer.

SYNTAX ERROR - Returned if the message fails to parse as a valid controller command.

8.4 RS-485 Troubleshooting

In the event of problems with the RS-485 communications verify the following items for proper configuration.

1. Check the configuration switch settings.
2. Ensure the baud rate, character framing, and interface protocol are matched to the host computer or terminal's requirements. Note that there can be several mismatched parameters.
3. Check the command syntax.
4. Ensure that the command strings output from the host computer or terminal to the 316 Controller are in accordance with the syntax defined.

8.4.1 Troubleshooting Guide

Symptom	Possible Cause
µP Failure LED is illuminated or flashing	Microcontroller failure.
No response or garbled output	Baud rate incorrect, Character length incorrect, or stop bit(s) incorrect.
Intermittently will not respond	Poor cable connections, ground fluctuations (the maximum common mode potential voltage across the system is 7 volts), or EMI from other sources. Bias resistors incorrect or non-existent. If the start character is not received properly, the controller may not interpret it as a start character and the controller will not respond. The Host software must be prepared to send a command if a response is not generated within a reasonable period of time. Timing between Rx and Tx not sufficient. See T0 and T1 constraints.
OVERRUN ERROR message	Stop bit(s) incorrect or host software failure.
PARITY ERROR message	Parity incorrect. Electrical noise on the transmission line.
SYNTAX ERROR message	Message to the 316 is not in accord with the specified syntax.

8.5 RS-485 Specifications

Function	Specification
Communications Format	RS-485, half-duplex, asynchronous
Data Rate	9600 (Default), 4800, 2400, 1200, 600, 300, 150 baud
Character Length	8-bit or 7-bit ASCII (Factory default is 8-bit)
Parity	No parity, even or odd (Factory default is None)
Stop Bits	1 or 2 (Factory default is 1)
Handshake	None (Poll/Response)
Address	256 selectable combinations (Factory default is 01)
Number of Connections	Up to 32 devices
Total Cable Length	4,000 feet maximum
Connectors	Two 9-pin D-sub (Parallel)

Chapter 9 - Linear Analog Output Module

9.1 Introduction

The Linear Analog Output Module provides three, zero to +10 Vdc, linearized voltages that correspond to the displayed pressure readings of the 316 Vacuum Gauge Controller. The source for these outputs is the digital data on the controller's internal bus to the Display Module. The analog output resolution is therefore dependent upon this data. The module is intended to be used in a 316 VGC configured with three gauges. The output is scaled for the thermocouple range of pressure.

9.2 Installation

The Module is installed in the controller in the slot normally assigned to the computer interface module.

9.2.1 Cable Connections

The output is via a "D" type 9-pin connector for which the mating parts have been supplied. The pin assignment, for the output connector, is defined in the following table:

Pin Assignments

Pin(s)	Function
1,2,4,6 & 8	Ground (both signal and chassis)
3	Not used
5	TC/CG "B" output
7	TC/CG "A" output
9	TC/CG/CM "C" output

9.3 Operation

The Linear Analog Output Module is in operation anytime power is "on". There are no accessible controls or adjustments.

Note: During periods where the front panel display is showing the process control setpoint, the analog outputs will lock up at the last valid pressure reading.

9.4 Calibration

Internal zero and full scale adjustment potentiometers are available for the three analog output channels. Adjustment should be rarely, if ever, required.

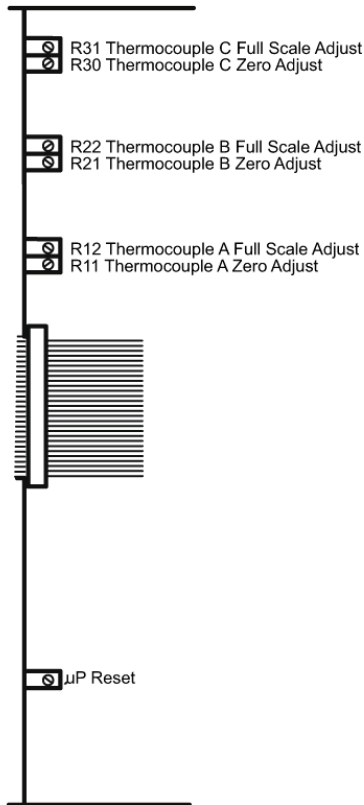

Figure 9-1 Linear Analog Module, Top View (Controller Cover Removed)

Potentiometer Designator	Function
R11	TC "A" zero adjust
R12	TC "A" full scale adjust
R21	TC "B" zero adjust
R22	TC "B" full scale adjust
R30	TC "C" zero adjust
R31	TC "C" full scale adjust

9.4.1 Gauge Output Zero Adjust

Set the gauge display to read "0" (Zero). Adjust TC Zero (R11 for channel A, R21 for channel B, or R30 for channel C) for exactly 0.00 Vdc on the appropriate TC output.

9.4.2 Gauge Output Full Scale Adjust

Set the gauge display to read 1.0 Torr. Adjust T. C. Full Scale (R12 for channel A, R22 for channel B, or R31 for channel C) for exactly 10.0 Vdc on the appropriate TC output.

9.5 Theory of Operation

The Linear Analog Output Module circuit consists of an embedded microcontroller and associated circuitry. The microcontroller picks off display data to the display module during the appropriate bus timing cycles and performs a digital-to-analog conversion by using the external associated circuitry.

9.6 Troubleshooting

Symptom	Possible Cause
μ P Failure LED is illuminated or flashing	Microcontroller failure

There are no other user troubleshooting procedures associated with the Linear Analog Output Module. If you are having difficulty with this module, contact Granville-Phillips Customer Service.

9.7 Specifications

Analog output loading: ± 2 mA max.

Thermocouple Output

Pressure Decade Range	Output Voltage	Smallest Increment	Comment
$< 10^{-3}$ Torr	0 Vdc	-	Zero Vdc output below 1 mT
10^{-3} Torr	10 - 99 mV	1 mV	1 mV = .1 mTorr
10^{-2} Torr	.1 V - .99 V	10 mV	0 mV = 1 mTorr
10^{-1} Torr	1.0 V - 9.9 V	100 mV	100 mV = 10 mTorr
≥ 1 Torr	10.0 V	-	

Index

316 VGC Basic Troubleshooting.....	16	Linear Analog Output Module Installation.....	72
316 VGC Cable Connections.....	13	Linear Analog Output Module Operation.....	72
316 VGC General Description.....	9	Linear Analog Output Module Specifications.....	74
316 VGC Installation.....	10	Linear Analog Output Module TC Full Scale Adjust.....	73
316 VGC Mounting Configurations.....	12	Linear Analog Output Module TC Zero Adjust.....	73
316 VGC Operation.....	14	Linear Analog Output Module Theory of Operation.....	74
316 VGC Specifications.....	18	Linear Analog Output Module Troubleshooting.....	74
316 VGC Theory of Operation.....	15	Microcontrollers and Bus Structure.....	15
Calibration.....	16	Module Installation.....	10
Capacitance Manometer Analog Output.....	47	Process Control Introduction.....	51
Capacitance Manometer Cable Installation.....	46	Process Control Module.....	51
Capacitance Manometer Calibration.....	48	Process Control Module Installation.....	51
Capacitance Manometer Initial Calibration.....	48	Process Control Operation.....	52
Capacitance Manometer Installation.....	45	Process Control Specifications.....	55
Capacitance Manometer Module.....	45	Process Control Theory of Operation.....	54
Capacitance Manometer Operation.....	47	Process Control Troubleshooting.....	55
Capacitance Manometer Reading Pressure.....	47	Repair Ordering.....	17
Capacitance Manometer Theory.....	15	RS-232 Baud Rate.....	56
Capacitance Manometer Theory of Operation.....	49	RS-232 Character Framing.....	56
Capacitance Manometer Troubleshooting.....	50	RS-232 Command Syntax.....	58
Cleaning the Convectron Gauge Tube.....	35	RS-232 Handshake.....	57
Convectron Analog Output.....	33	RS-232 Installation.....	56
Convectron Analog Output Adjustment.....	34	RS-232 Invert RTS.....	57
Convectron Atmosphere Adjustment.....	34	RS-232 Module.....	56
Convectron Gauge Calibration and Maintenance.....	34	RS-232 Operation.....	57
Convectron Gauge Contamination.....	21	RS-232 Specifications.....	61
Convectron Gauge Display Resolution.....	38	RS-232 Talk-Only Mode.....	57
Convectron Gauge Module.....	20	RS-232 Theory of Operation.....	59
Convectron Gauge Mounting Position.....	20	RS-232 Troubleshooting.....	60
Convectron Gauge Operation.....	24	RS-485 Address.....	66
Convectron Gauge Specifications.....	38	RS-485 Baud Rate.....	67
Convectron Gauge Theory.....	15	RS-485 Character Framing.....	67
Convectron Gauge Theory of Operation.....	36	RS-485 Command Syntax.....	70
Convectron Gauge Troubleshooting.....	36	RS-485 Computer Interface.....	67
Convectron Gauge Tube Installation.....	22	RS-485 Installation.....	66
Convectron Gauge Tube Orientation.....	23	RS-485 Module.....	66
Convectron High Indicated Pressure.....	20	RS-485 Response Delay.....	67
Convectron Indicated vs. True Pressure Curves.....	25	RS-485 Specifications.....	71
Convectron Overpressure.....	20	RS-485 Troubleshooting.....	71
Convectron Sensor Failure.....	21	Safety Instructions.....	7
Convectron Troubleshooting Guide.....	37	Service Form.....	19
Convectron Units of Pressure Measurement.....	21	Specifications.....	50
Convectron Zero Adjustment.....	34	Thermocouple Gauge Analog Output.....	40
Explosive Gases.....	7	Thermocouple Gauge Atmosphere Adjustment.....	42
General Warnings.....	7	Thermocouple Gauge Calibration.....	41
Hazardous Voltage.....	7	Thermocouple Gauge Module.....	39
IEEE 488 Command Syntax.....	63	Thermocouple Gauge Module Installation.....	39
IEEE 488 Installation.....	62	Thermocouple Gauge Operation.....	40
IEEE 488 Interface Bus Address.....	62	Thermocouple Gauge Reading Pressure.....	40
IEEE 488 Module.....	62	Thermocouple Gauge Specifications.....	44
IEEE 488 Operation.....	63	Thermocouple Gauge Theory of Operation.....	42
IEEE 488 Specifications.....	65	Thermocouple Gauge Troubleshooting.....	43
IEEE 488 SRQ Mode.....	63	Thermocouple Gauge Tube Installation.....	40
IEEE 488 Talk-Only Mode.....	63	Thermocouple Gauge Units of Measure.....	39
IEEE 488 Troubleshooting.....	64	Thermocouple Gauge Zero Adjustment.....	41
Implosion or Explosion.....	7	Units of Measure.....	14
Instrument Grounding.....	14		
Line Voltage Selection.....	10		
Linear Analog Output Module.....	72		
Linear Analog Output Module Calibration.....	72		

Red LED ON indicates failure

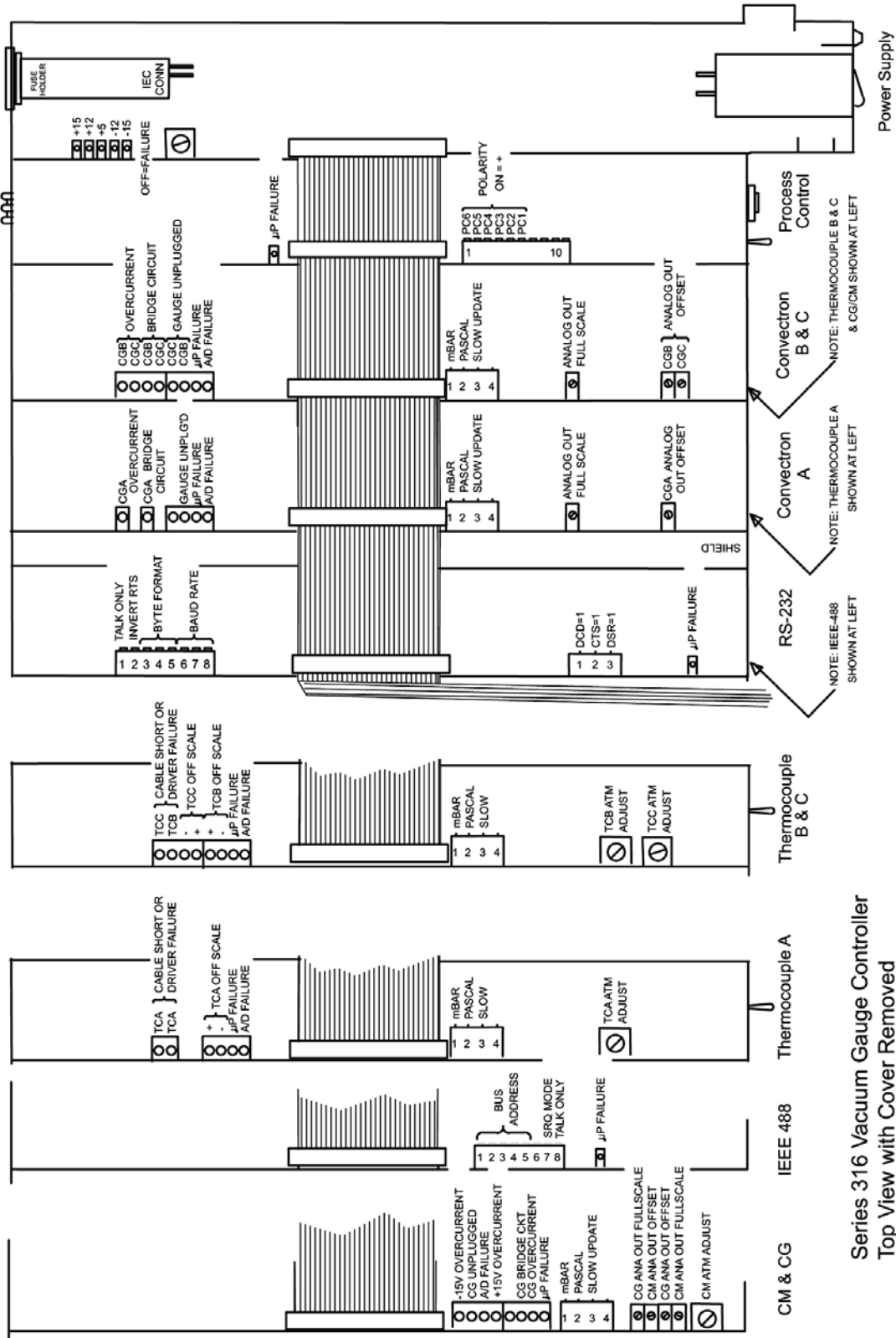

Series 316 Vacuum Gauge Controller
Top View with Cover Removed

Series 316

Granville-Phillips® Series 316 Convectron® Vacuum Measurement Controller

GRANVILLE-PHILLIPS®

Customer Service/Support

For customer service within the USA, 8 AM to 5 PM
Mountain Time Zone, weekdays excluding holidays:

Granville-Phillips

6450 Dry Creek Parkway
Longmont, CO 80503 USA

Phone: +1-800-776-6543
Phone: +1-303-652-4400
FAX: +1-303-652-2844
Email: co-csr@brooks.com

Brooks Automation, Inc.

15 Elizabeth Drive
Chelmsford, MA 01824 USA

Phone: +1-978-262-2400

For customer service, 24 hours per day, 7 days per week,
every day of the year including holidays within the USA:

Phone +1-800-367-4887

World Wide Web: www.brooks.com

Instruction Manual

Instruction manual part number 316005

Revision B - December 2012

