



nEXT Turbomolecular pumps

nEXT85

INSTRUCTION MANUAL

Copyright notice

©Edwards Limited 2020. All rights reserved.

Associated publications

Publication title	Publication number
Vacuum pump and vacuum system safety	P40040100

Trademark credit

Edwards and the Edwards logo are trademarks of Edwards Limited, Innovation Drive, Burgess Hill, West Sussex RH15 9TW.

Disclaimer

The content of this manual may change from time to time without notice. We accept no liability for any errors that may appear in this manual nor do we make any expressed or implied warranties regarding the content. As far as practical we have ensured that the products have been designed and constructed to be safe and without risks when properly installed and used in accordance with their operating instructions.

We accept no liability for loss of profit, loss of market or any other indirect or consequential loss whatsoever.

Product warranty and limit of liability are dealt with in our standard terms and conditions of sale or negotiated contract under which this document is supplied.

You must use this product as described in this manual. Read the manual before you install, operate, or maintain the product.

CE Declaration of Conformity

Edwards Ltd
Innovation Drive
Burgess Hill
West Sussex
RH15 9TW
UK

The following product

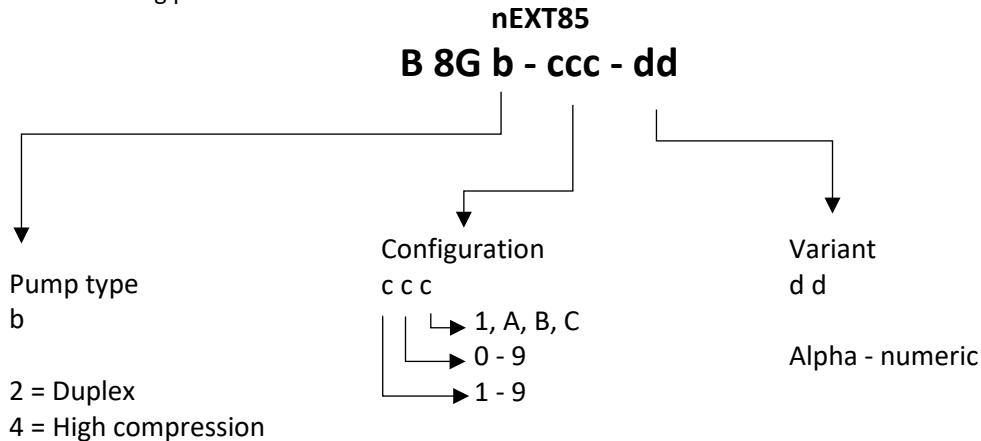

Is in conformity with the relevant requirements of European CE legislation:

2006/42/EC	Machinery directive
2014/35/EU	Low voltage directive (LVD) as applicable to electrical sub-assemblies
2014/30/EU	Electromagnetic compatibility (EMC) directive
2011/65/EU	Restriction of certain hazardous substances (RoHS) directive as amended by Delegated Directive (EU) 2015/863

Based on the relevant requirements of harmonised standards:

EN 1012-2:1996 +A1:2009	Compressors and vacuum pumps. Safety requirements. Vacuum pumps
EN 61010-1:2010	Safety requirements for electrical equipment for measurement, control and laboratory use. General requirements
EN 61326-1:2013	Electrical equipment for measurement, control and laboratory use. EMC requirements. General requirements Class B Emissions, Industrial Immunity

Documentation Officer: Jelena Havelkova, Spielberg Office Centre, Holandska 10, Brno, 63900 Czech Republic,
☎: +42(0) 734 418 896, ✉: documentation@edwardsvacuum.com

This declaration, based on the requirements of the listed Directives and EN ISO/IEC 17050-1, covers all product serial numbers from this date on: *11th November 2019*

Petr Smerek – Engineering Manager
Scientific Vacuum Division
Lutin

Ian Keech – General Manager
Lutin

Additional Legislation and Compliance Information

EU EMC Directive: Class A/B equipment

Caution: This equipment is not intended for use in residential environments and may not provide adequate protection to radio reception in such environments.

EU RoHS Directive: Material Exemption Information

This product is compliant with the following Annex III Exemptions:

- 6(b) **Lead** as an alloying element in aluminium containing up to 0.4% by weight
- 6(c) Copper alloy containing up to 4% **lead** by weight
- 8(b) **Cadmium** and its compounds in electrical contacts

EU REACH Regulation Compliance

This product is a complex article which is not designed for intentional substance release. To the best of our knowledge the materials used comply with the requirements of REACH. The product manual provides information and instruction to ensure the safe storage, use, maintenance and disposal of the product including any substance based requirements.

Article 33.1 Declaration

This product does not knowingly or intentionally contain Candidate List Substances of Very High Concern above 0.1%ww by article as clarified under the 2015 European Court of Justice ruling in case C-106/14.

- Cadmium (Cd) added to the Candidate List June 2013

As indicated by the applied RoHS exemption above, this substance is present in electronic componentry

- Lead (Pb) added to the Candidate List June 2018

As indicated by the applied RoHS exemption(s) above this substance is present in certain aluminium/brass components

ADDITIONAL INFORMATION

The products listed are also in scope for and comply with the requirements of the following:

2012/19/EU	Directive on waste electrical and electronic equipment (WEEE)
Product is certified to CSA-C22.2 No.61010-1-12	Safety requirements for electrical equipment for measurement, control and laboratory use – Part 1: General requirements
Product conforms to UL61010-1 3 rd Edition	Safety requirements for electrical equipment for measurement, control and laboratory use – Part 1: General requirements
Russia EAC	Intertek certification

材料成分声明
China Material Content Declaration

部件名称 Part name 	铅 Lead (Pb)	汞 Mercury (Hg)	镉 Cadmium (Cd)	六价铬 Hexavalent Chromium (Cr VI)	多溴联苯 Polybrominated biphenyls (PBB)	多溴二苯醚 Polybrominated diphenyl ethers (PBDE)
铸铝及铝合金制品 Aluminium alloys	X	O	O	O	O	O
铜管管件 Brass pipe fitting	X	O	O	O	O	O
铜接头 Brass connectors	X	O	O	O	O	O
印刷电路组件 (PCA) Printed Circuit Assembly (PCA)	X	O	X	O	O	O
<p>O: 表示该有害物质在该部件的所有均质材料中的含量低于 GB/T 26572 标准规定的限量要求。 O: Indicates that the hazardous substance contained in all of the homogeneous materials for this part is below the limit requirement in GB/T 26572.</p> <p>X: 表示该有害物质在该部件的至少一种均质材料中的含量超出 GB/T26572 标准规定的限量要求。 X: Indicates that the hazardous substance contained in at least one of the homogeneous materials used for this part is above the limit requirement of GB/T26572.</p>						

This page has been intentionally left blank.

Contents

1. Safety and compliance.	8
1.1 Definition of Warnings and Cautions.	8
1.2 Safety symbols.	8
2. Introduction.	10
2.1 Overview.	10
2.2 Motor controller.	11
2.3 Operational features.	12
2.3.1 Power limit setting.	12
2.3.2 Standby speed.	12
2.3.3 Timer.	12
2.3.4 Analogue output.	13
2.3.5 Automatic vent options.	13
2.3.6 Normal speed setting.	14
2.3.7 Electronic braking.	14
2.4 Logic interface.	14
2.4.1 USB interface.	15
2.4.2 Parallel control and monitoring.	15
2.4.3 Serial control and monitoring.	15
2.4.4 Serial control with parallel monitoring.	16
2.4.5 Parallel control with serial monitoring or serial configuration.	16
2.4.6 Motor controller configuration (serial configuration).	16
3. Technical data.	18
3.1 General technical data.	18
3.2 Operating and storage conditions.	20
3.3 Vent gas specification and vent control data.	20
3.4 Purge gas specification.	21
3.5 Cooling water	22
3.6 Electrical data.	22
3.7 Pumping media.	23
3.8 Materials exposed to gases pumped.	24
3.9 Logic interface connector.	25
3.10 Motor controller auxiliary connector socket.	28
3.11 Indicator LEDs.	29
3.12 Pump performance data.	30
4. Installation.	35
4.1 Unpack and inspect.	35
4.2 Connect to the vacuum system.	37
4.2.1 Remove and replace the inlet screen.	37

4.2.2	Mount the pump.	38
4.2.3	Backing port connection.	40
4.2.4	Interstage connection.	41
4.3	Purge gas connection.	41
4.3.1	Recommended purge gas flow.	41
4.3.2	Connect the purge gas.	41
4.4	Electrical installation.	41
4.4.1	Ground the connections.	42
4.4.2	Connect the logic interface to the TIC or TAG.	42
4.4.3	Connect the logic interface to the control equipment.	42
4.5	Connect the parallel control and monitoring.	43
4.6	Connection for serial control and monitoring.	45
4.6.1	Connect the serial interface to the customer control equipment.	45
4.6.2	Serial enable.	47
4.6.3	Serial protocol.	47
4.6.4	Command set.	48
4.6.5	Multi-drop operation.	52
4.7	Connection for mixed parallel and serial operation.	54
4.8	Cooling.	55
4.8.1	Cooling requirements.	55
4.8.2	Forced air cooling.	56
4.8.3	Water cooling.	56
5.	Configuration.	58
5.1	Configure the pump using serial commands.	58
5.1.1	Message structure.	58
5.1.2	Command and reply table definitions.	59
5.1.3	Power limit setting.	59
5.1.4	Power supply to the fan from the motor controller.	60
5.1.5	Controlled venting options.	60
5.1.6	Standby speed setting.	61
5.1.7	Normal speed setting.	62
5.1.8	Timer setting and options.	62
5.1.9	Analogue signal options.	63
5.1.10	Electronic braking options.	64
5.1.11	Factory settings.	64
5.1.12	Assigning a multi-drop address.	64
5.2	Configure the pump using a TIC.	65
6.	Operation.	67
6.1	Before starting the pump.	67
6.1.1	Close the vent valve.	67
6.1.2	Pre-start sequence.	67
6.2	Vent options, vent valve connection and control.	68

6.2.1	Manual vent valve.	68
6.2.2	TAV5 solenoid vent valve.	68
6.2.3	Vent valve control.	69
6.2.4	Alternative valve connected to the vacuum system.	71
6.3	Operation with parallel control and monitoring.	72
6.3.1	Start the pump.	72
6.3.2	Run the pump at standby speed.	72
6.3.3	Stop the pump.	72
6.3.4	Parallel monitoring.	73
6.4	Operation with serial control and monitoring.	73
6.4.1	Delayed start.	73
6.4.2	Start the pump.	73
6.4.3	Run the pump at standby speed.	74
6.4.4	Stop the pump.	74
6.4.5	Monitor temperature readings.	75
6.4.6	Monitor link parameter readings.	75
6.4.7	Monitor measured motor speed.	75
6.5	Mixed parallel and serial operation.	76
6.6	Operation with a TIC or TAG.	77
6.7	Decelerating and venting.	77
6.8	Operation at extreme conditions.	78
6.8.1	Operation with high inlet pressure.	78
6.8.2	Operation at high temperatures.	78
6.8.3	Protection against over-speed.	79
6.8.4	Electrical supply failure.	79
6.9	Bakeout.	80
6.10	Shut down the pump manually.	81

7. Maintenance. 82

7.1	Bearing and oil cartridge maintenance.	82
7.2	Rotor life.	82
7.3	Cleaning the pump.	82
7.4	Decoding service status words.	83
7.5	Controller run time.	84
7.6	Pump run time.	84
7.7	Pump cycles.	84
7.8	Bearing run time.	85
7.9	Oil cartridge run time.	85

8. Fault finding. 86

8.1	The controller LEDs do not flash for 0.5 seconds when the system is set to on.	86
8.2	The pump does not rotate after a parallel start command is sent.	86
8.3	The pump does not rotate after a serial start command is sent.	86
8.4	The pump does not respond in multi- drop mode.	86

8.5	The green Normal LED does not light or the pump does not rotate at full speed or the pump fails while in operation.	87
8.6	Ultimate pressure cannot be reached.	87
8.7	The pump is very noisy or there is excessive vibration or both.	88
8.8	No serial comms.	88
8.9	Fail signal or standby signal not working.	88
8.10	Yellow service LED is flashing a repeated sequence.	89
8.11	The red alarm LED is on.	89
8.12	The red alarm LED is flashing.	89
8.13	Other problems.	89
8.14	Command set error codes.	89
8.15	Flashing service codes.	90
8.16	Flashing error codes.	90
8.17	Decoding system status words.	91
8.18	Service information.	93
9.	Storage.	95
10.	Disposal.	96
11.	Service.	97
11.1	Return the equipment or components for service	97
11.2	Bearing and oil cartridge on-site maintenance.	98
12.	Spares.	99
12.1	Inlet screen.	99
12.2	Inlet strainer.	99
12.3	Inlet flange seals and integrated inlet screens.	99
12.4	NW16 and NW25 ports.	100
13.	Accessories.	101
13.1	Air cooler.	101
13.2	Water cooler.	101
13.3	Flange heater.	102
13.4	TAV5 vent valve.	102
13.5	VRX vent restrictor.	102
13.6	Vent port adaptor.	103
13.7	PRX purge restrictor.	103
13.8	Interface cable.	103
13.9	nST PC program.	103
13.10	Auxiliary connector.	104
13.11	Auxiliary extension cable.	104
13.12	Auxiliary 'Y' cable adaptor.	105
13.13	Base mounting adaptor.	105

List of Figures

Figure 1: Dimensions - nEXT85 ISO63.	18
Figure 2: Dimensions - nEXT85 CF63.	19
Figure 3: Dimensions - nEXT85 ISO100.	19
Figure 4: Dimensions - nEXT85 DN40.	19
Figure 5: Typical base view.	20
Figure 6: Maximum allowed rate of pressure rise during venting: pressure against time (with pump initially at full rotational speed).	21
Figure 7: Maximum relative humidity to avoid condensation with water cooling.	22
Figure 8: Interface circuits for nEXT turbo pump controllers.	27
Figure 9: Valve connector.	29
Figure 10: nEXT85 pumping speed versus inlet pressure performance graph.	31
Figure 11: nEXT85 compression ratio versus backing pressure graph.	31
Figure 12: Typical pumping system with a nEXT pump.	36
Figure 13: Allowable pump orientation.	40
Figure 14: Logic interface connections - parallel control.	45
Figure 15: Motor controller status information.	46
Figure 16: Logic interface connections - RS232 serial control.	46
Figure 17: Logic interface connections - RS485 serial control.	47
Figure 18: Conceptual diagram for multi-drop connection using RS232 interface.	53
Figure 19: RS485 multi-drop connection.	54
Figure 20: Logic interface connection - mixed parallel and serial operation.	55
Figure 21: Auxiliary interface connection.	71
Figure 22: Serial and parallel control flowchart.	77
Figure 23: Accessories.	101

This page has been intentionally left blank.

1. Safety and compliance

1.1 Definition of Warnings and Cautions

NOTICE:



This manual meets our obligation to provide you with information. For safe operation from the start, read these instructions carefully before you install or commission the equipment.

Read all the safety instructions in this section and the rest of this manual carefully and make sure that you obey these instructions. The equipment must only be operated and maintained by trained personnel in the proper condition and as described in this instruction manual.

Obey local and state requirements and regulations. If you have any questions about safety, operation or maintenance of the device, please contact our nearest subsidiary.

Important safety information is highlighted as warning and caution instructions. Obey these instructions.



WARNING:

If you do not obey a warning, there is a risk of injury or death. Different symbols are used according to the type of hazard.



CAUTION:

If you do not obey a caution, there is a risk of minor injury, damage to equipment, related equipment or process.



NOTICE:

Information about properties or instructions for an action which, if ignored, will cause damage to the pump or the system.







We reserve the right to change the design and the stated data. The illustrations are not binding.

Keep the instructions for future use.

1.2 Safety symbols

The safety symbols on the products shows the areas where care and attention is necessary.

The safety symbols that follow are used on the product or in the product documentation.

	<p>Warning/Caution A safety instruction which must be followed.</p>
	<p>Warning - Dangerous voltage Identifies possible hazards from dangerous voltages.</p>
	<p>Warning - Hot surfaces Identifies a potential hazard from a hot surface.</p>
	<p>Warning - Protective earth (ground) The equipment must be grounded.</p>
	<p>Warning - Use protective equipment Use appropriate protective equipment.</p>
	<p>Warning - Risk of explosion An indication that there is a risk of explosion when you do the task.</p>

2. Introduction

2.1 Overview



WARNING: SAFE EQUIPMENT USE

Risk of injury or damage to equipment. Improper use of the equipment could cause damage to it or injury to people. The user is responsible for the safe operation, installation and monitoring of the system.



WARNING: DANGEROUS FUMES

Risk of asphyxiation. The drive contains electrolytic capacitors and, under certain fault conditions, may emit dangerous fumes. Ensure that the drive is operated in a well-ventilated area.



CAUTION: ELECTRICAL CONNECTIONS

Risk of damage to equipment. Do not attempt to separate the controller from the pump since this will cause damage to the electrical connections.

A nEXT pump has a turbomolecular pump with a permanently attached controller which contains the drive electronics.

The controller controls the electrical supply to the pump. With the controller, you can manually adjust the standby speed. Other controls can be operated through the logic interface only. To operate the nEXT pump, connect it to the customer control equipment and to the power supply or use manufacturer's TIC Turbo Instrument Controller, TIC Turbo Controller or TAG Controller. Refer to [Electrical data on page 22](#).

The controller drives the brush-less motor in the pump. Two variants of the pump are:

- The 'D' or 'Duplex' variant which has turbomolecular blades and a drag mechanism that allows operation at higher backing pressures than the pure turbomolecular pumps.
- The 'H' or 'High Compression' variant which has the same technology as the 'D' variant, but it is tuned to deliver higher compression.

Also available is an 'iD' or 'iH' interstage variant, which provides an interstage port between the turbomolecular blades and drag mechanism.

The nEXT pump is supplied with an inlet screen. The inlet screen is installed in the centering O-ring for ISO and NW40 version pumps and in the envelope for CF version pumps. The inlet screen prevents damage to the pump caused by debris entering the pump.

The nEXT pump has a vent port for venting the pump and vacuum system to the atmospheric pressure. The pump has a manual vent valve which can be replaced with a TAV5 solenoid-operated vent valve (available as an accessory, refer to [Accessories on page 101](#)). The on-board motor controller can control the TAV valve.

The nEXT pump has a purge port through which an inert purge gas can be introduced to protect the bearing and motor from corrosion. You can install an optional vent port

adapter and purge restrictor to the purge port to control the flow rate of the purge gas and to filter the gas supply. This can be used to optimise the performance of the pump, for example with low molecular mass gases. Refer to [Accessories on page 101](#).

A forced air-cooling kit and a water-cooling block are available as optional accessories to cool the nEXT pump. Refer to [Accessories on page 101](#).

 **Note:**

The units used throughout this manual conform to the SI international system of units of measurement. Also throughout this manual, wherever flow rates are specified, the abbreviation 'sccm' is used to mean standard $\text{cm}^3\text{min}^{-1}$: this is a flow of $1 \text{ cm}^3\text{min}^{-1}$ at an ambient temperature of $0 \text{ }^\circ\text{C}$ and a pressure of 1013 mbar ($1.013 \times 10^5 \text{ Pa}$).

2.2 Motor controller

The motor controller has the drive electronics that control the pump operation, the TAV vent valve and the air cooler.

An auxiliary connector socket is given at the side of the motor controller where you can plug in the TAV vent valve and the air cooler. Refer to [Motor controller auxiliary connector socket on page 28](#).

A USB port ([Figure: Motor controller status information on page 46](#), item 9) is given which is a service port to use with our nST PC software using a standard micro-USB cable. This enables the pump to be configured, monitored and upgraded without disconnecting from the 24 - 48 V d.c. supply. This software is available for download from our Upgrade website: www.upgrades.edwardsvacuum.com

Currently, for the nST software, a free license is necessary to use the software. To get a free license, obey the on-screen instructions, complete the user data form and send the automatically generated email to us.

The controller has five indicator LED's which signal the general status, operation and service status of the pump. The LEDs can be used for fault finding if a problem occurs. Refer to [Indicator LEDs on page 29](#).

The motor controller has built-in safety features to prevent the pump from damage during sustained high pressure or temperature.

- The electronics constantly monitors the temperature in the controller and the temperature of the motor in the pump. If the controller or the motor gets too hot, the controller decreases the power supplied to the pump motor and the pump speed decreases. If the rotational speed of the pump decreases below 50% of the full speed, the electronics can trip into a fail condition, depending on the system configuration. Refer to [Timer on page 12](#).
- If the pump inlet pressure increases, the power supplied to the pump motor increases to counteract the gas frictional load. When the built-in maximum power limit is reached, the speed of the pump starts to decrease. If the rotational speed of the pump decreases below 50% of the full speed, the electronics can trip into fail condition, depending on how the system has been configured. Refer to [Timer on page 12](#).

If the electrical supply fails, the controller uses the motor in the pump as a generator. This means the pump has its own regenerative supply and a separate battery for emergency power backup is not necessary. The regenerated energy maintains the

electrical supply to the controller, the vent valve or the fan attached to the controller connector until the pump speed decreases below 50% of the full rotational speed to make sure that the vent valve stay shut until below 50% of the full rotational speed and prevent the pump from venting at full speed. It makes sure that the serial link and signals on the parallel interface stays active until the pump speed decreases below 50%.

2.3 Operational features

The pumps have basic start and stop commands and some other features that allow the pump operation to be modified for an applicable application.

2.3.1 Power limit setting

Select the maximum power that will be drawn by the pump. The more power supplied, the quicker the pump will accelerate to reach full speed.

If the application requires fast cycling or higher gas loads, set the power limit to the maximum value. If ramp time is not important in the application, use a lower power limit, down to a minimum value (refer to [Table: Power limit setting on page 60](#)). Also ensure there is sufficient cooling for the application.

Ensure that the power supply is capable of delivering sufficient power to the nEXT pump. By choosing a lower power limit setting, a smaller power supply may be used. For more information, refer to [Electrical data on page 22](#).

2.3.2 Standby speed

In standby mode, the pump rotational speed is lower than the full rotational speed. The default setting for standby speed is 70% of the full speed.

To operate the pump at standby speed, it must be in the start condition.

If operating the pump at maximum speed at all times is not necessary for the application, use the standby speed feature rather than setting the pump to off. You can use the standby speed feature for tuning the vacuum system or as a power saving option for the system.

The standby speed is a user-selectable value. Refer to [Standby speed setting on page 61](#).

2.3.3 Timer

When the pump is started, an internal timer starts automatically in the motor controller. The default timer setting is 8 minutes.

If the pump fails to reach 50% of full rotational speed in the timeout period, the motor controller will signal a fail and decelerate the pump to rest. This feature prevents the motor controller from driving the pump at maximum power for a long time. The pump can fail to reach 50% speed if the gas load is too high (for example if there is a leak in the system), if the backing pump fails or if the pump is too hot.

The timeout period is user-selectable (refer to [Timer setting and options on page 62](#)). If slow ramp-up of the pump is necessary for the application, extend the timeout period. The timer is permanently enabled for ramp-up.

If the rotational speed of the pump decreases below 50% of the full speed, the pump time can be set to recover rather than trigger a fail condition. The timer starts

immediately when the rotational speed of the pump decreases below 50% of the full speed. If the rotational speed of the pump increases above 50% during the timeout period, the timer will reset. If the rotational speed of the pump does not recover by the end of the timeout period, the motor controller will trigger a fail condition and decelerate the pump to rest.

The timer function is enabled when the pump is shipped. You can disable the timer function. If the timer function is disabled, the pump will fail and decelerate to rest immediately when the rotational speed of the pump decreases below 50%.

2.3.4 Analogue output

The pump controller gives an analogue output for monitoring five parameters of the system:

- Measured pump rotational speed (default condition)
- Measured link power
- Measured motor temperature
- Measured controller temperature
- Measured rotor power

The range of the analogue output signal is from 0 to 10 V and is directly proportional to the system parameter. Refer to [Logic interface on page 14](#).

Connect the analogue output to an applicable meter or indicator to display the applicable system parameter or connect it to the customer control equipment (for example, to operate other components in the pumping system at set values).

The analogue output can monitor only one system parameter at a time. You can configure the controller to monitor a different system parameter. Refer to [Analogue signal options on page 63](#).

2.3.5 Automatic vent options

The manufacturer's TAV vent valve can be connected to the motor controller. The motor controller can give a number of different venting options and can be configured for a normally closed and a normally open vent valve.

The motor controller can control the rate of venting. Using this feature, the pump can be vented from the full rotational speed in a controlled manner that will not damage the pump bearings. When the pump rotational speed decreases below 50% of the maximum speed, it is safe to do a hard vent (open the vent valve fully).

Many venting options are available, that include:

- Hard vent when the rotational speed decreases below 50% speed.
- Controlled vent when the rotational speed is above 50% speed and hard vent is below 50% speed.
- Hard vent immediately through an applicable restrictor.

Controlled venting gives quicker ramp down time by controlling the vent rate through a single large orifice across the speed range of the pump. A list of the venting options is given in [Vent options, vent valve connection and control on page 68](#).

There is also a feature that allows a delayed start of the pump. With this feature, the vent valve can be closed before starting the pump. This allows the backing pump to decrease the pressure in the vacuum system before starting the pump.

With a 'Y' cable adaptor, a TAV and a cooling fan can be controlled at the same time. No configuration is necessary.

2.3.6 Normal speed setting

The normal speed is a user-selectable parameter which can be set from 50% to 100% of full rotational speed.

When the pump gets to normal speed, a signal is available on the normal pin of the logic interface connector. The signal can be used to control the application as it shows that the vacuum performance (pump speed) is at a set level. The default setting is 80% of the full rotational speed. Refer to [Normal speed setting on page 62](#) for instructions to change the normal speed setting.

2.3.7 Electronic braking

The pump has a user-selectable electronic braking option which is disabled by default. With the electronic braking option disabled, the pump will take power from the electrical supply during acceleration and operation.

When the pump decelerates it will coast down and power will not be returned to the electrical supply.

The electronic braking option can be enabled to decrease the pump deceleration time and to recover some energy from the pump. This can be done by returning the power from the pump to the electrical supply. The rate at which the electrical energy is returned to the supply is regulated to the voltages shown:

Voltage range	Returned electronic braking voltage
Below 21.6 V d.c. (24 V d.c. -10%)	Outside working range for pump
21.6 V d.c. to 26.4 V d.c.	24 V d.c. +10%
26.4 V d.c. to 38.4 V d.c.	Electronic braking not functional
38.4 V d.c. to 50.4 V d.c.	48 V d.c. +10%
Above 50.4 V d.c. (48 V d.c. +5%)	Outside working range for pump

To get the fastest electronic braking times, the returned power must go to somewhere, such as:

- A supply capable to receive the returned power.
- Other devices that share the same electrical supply bus with the pump.
- An applicable 2 A load during the deceleration of the pump.

2.4 Logic interface

The pump controller can be operated only through the logic interface. The signals on the logic interface are of three types:

- Control inputs: Switch-type signals that are used to control the pump
- Status outputs: To identify the status of the system

- Analogue output: Gives a 0 - 10 V output for a number of pump parameters.

The logic interface supports the serial control and the parallel control to monitor and control through one connector. For serial control, RS232 (default) or RS485 can be selected using the RS485 / RS232 slide switch which is given on the motor controller. Refer to [Connection for serial control and monitoring on page 45](#).

You can plug the logic interface into the manufacturer's TIC Turbo Controller or TIC Turbo Instrument Controller and then use the given functionality. The logic interface can be connected to the customer control system as an alternative.

Refer to [Logic interface connector on page 25](#) for more information about the logic interface.

2.4.1 USB interface

The USB service port is designed to work with manufacturer's nST PC software. The primary function of the interface is to allow an easy configuration of the pump.

The START / STOP option is given to check the pump operation through the USB service port. It is not intended as an industrial control interface for unattended machine to machine (M2M) control.

The USB service port supports the same time communications with the serial interface in the logic interface connector. This enables the review of the pump status and logs, and you can configure the pump while the pump is installed and in operation.

Use the USB service port only when the 24 - 48 V d.c. power is applied. Do not use the USB service port without 24 - 48 V d.c. power as there is a risk of corruption of the pump controller memory.

2.4.2 Parallel control and monitoring

The simple parallel interface is a quick and easy way to control the pump. Same interface is used on the 24 V manufacturer's Turbo Pumps. The start and standby controls are available to use. You can monitor the system status using the normal, fail and analogue output signals.

Refer to [Connect the parallel control and monitoring on page 43](#) for more instructions about how to use the parallel interface.

A system that is in operation with a parallel connection only is not capable to adjust the configuration settings stored in the controller (for example, power limit setting or controlled venting options). All these features will be at factory default settings. You can manually adjust the standby speed if the standby mode is selected, but the motor controller has to be configured separately before the installation of the pump to the system. Refer to [Parallel control with serial monitoring or serial configuration on page 16](#) and [Motor controller configuration \(serial configuration\) on page 16](#) for more information.

2.4.3 Serial control and monitoring

The serial communications link gives complete control and monitoring by using three signal lines.

The serial data lines have the same connector pins as the parallel signals standby and fail. The serial data lines can be configured to give an RS485 compliant or RS232

compatible interface by setting the position of the RS485 / RS232 slide switch. Refer to [Connection for serial control and monitoring on page 45](#).

The serial enable signal must be linked to 0 V for the system to accept commands from the serial link. This is a safety feature which operates as an interlock. For pure serial control, the parallel start signal will be left unconnected.

The motor controller will continue to give normal and analogue signals on the logic interface connector even when operating under serial control. You can get the status of the normal signal and the value of the system parameter on the analogue output by interrogating the system status through the serial link.

Refer to [Connection for serial control and monitoring on page 45](#) for more information about the serial interface.

2.4.4 Serial control with parallel monitoring

Normal and analogue signals stay available when using serial control. You can control the pump through the serial link while monitoring the normal and analogue signals in the parallel interface.

The serial link uses the same connector pins as the parallel signals standby and fail so these parallel control and monitoring signals are not available. The serial enable signal must be linked to 0 V and the parallel start signal will be left unconnected.

2.4.5 Parallel control with serial monitoring or serial configuration

Use this configuration to operate the pump in parallel control mode, with the option to:

- adjust the configuration settings stored in the motor controller or
- monitor operational status of the pump through the serial link or through the USB service port.

If using the USB service port with manufacturer's nST PC software, it is not necessary to link the serial enable signal to 0 V for the serial communications to take place. While operating under parallel control with the USB service port, all parallel control and monitoring signals are available (as given in [Parallel control and monitoring on page 15](#)), which include the standby control line and fail monitoring line.

If using the serial link, the serial enable signal must be linked to 0 V for serial communications to take place. While operating under parallel control with the serial link active, the parallel start control signal is available (as given in [Parallel control and monitoring on page 15](#)), but the standby control line will not be available as it is used as a serial data line.

If the serial enable line is deactivated while the RS485 / RS232 slide switch is in the RS232 position, the serial link has to be disconnected. We recommend you to make a special cable for the serial communications that includes a link between the serial enable and 0 V. This way, the serial enable is automatically activated when the cable is connected and deactivate when the cable is removed.

2.4.6 Motor controller configuration (serial configuration)

All configuration settings stored in the motor controller are kept when the power to the pump is removed so that it is possible to use another system to configure the motor controller before the installation of the pump at the application. You can configure the

operation of the pump as per the application and the pump can be operated using a simple parallel interface system.

To configure the nEXT pump, use a customer simple serial system through the serial link, or use manufacturer's TIC Turbo Controller, TIC Turbo Instrument Controller or TAG Controller. The TICs allow the storage of a pump's configuration. You can download the configuration to another nEXT pump. This is useful when you configure a number of nEXT pumps with the same settings before they are installed at a system.

The USB service port can be used with the manufacturer's nST PC software to configure the pump. You can download the configuration to another pump which is useful when you configure a number of nEXT pumps.

3. Technical data

3.1 General technical data

Table 1 General technical data

General items	Reference data
Dimensions	Refer to Figure: Dimensions - nEXT85 ISO63 on page 18 , Figure: Dimensions - nEXT85 CF63 on page 19 , Figure: Dimensions - nEXT85 ISO100 on page 19 and Figure: Dimensions - nEXT85 DN40 on page 19 .
Maximum inlet flange temperature	120 °C
Maximum permitted external magnetic field	5 mT Radial (for standard aluminium envelope pump)
Pollution degree	61010-1 Pollution degree 2
Equipment type	Fixed equipment, for indoor use only
Enclosure protection (installed)	IP64
Power supply	24 - 48 V d.c. (Refer to Electrical data on page 22 for additional information)

Figure 1 Dimensions - nEXT85 ISO63

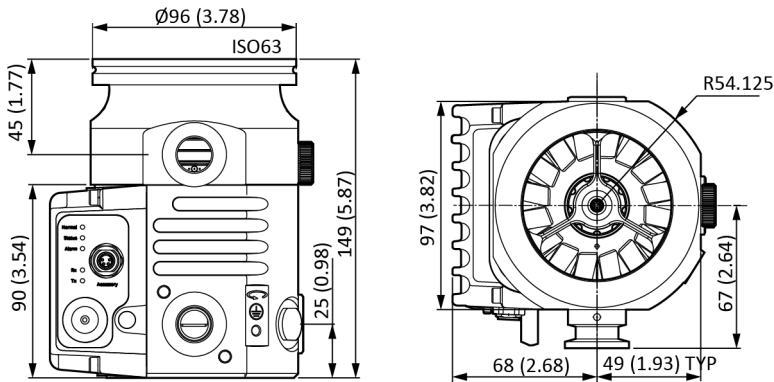

All measurements shown are in mm (inches)

Figure 2 Dimensions - nEXT85 CF63

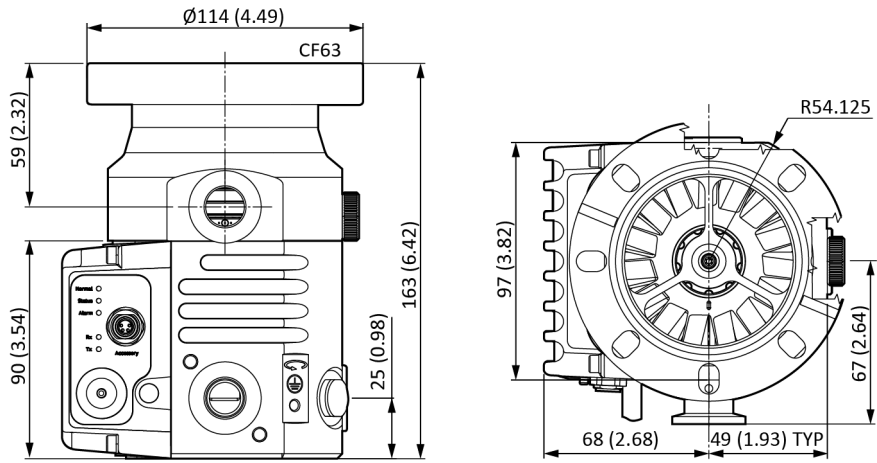

All measurements shown are in mm (inches)

Figure 3 Dimensions - nEXT85 ISO100

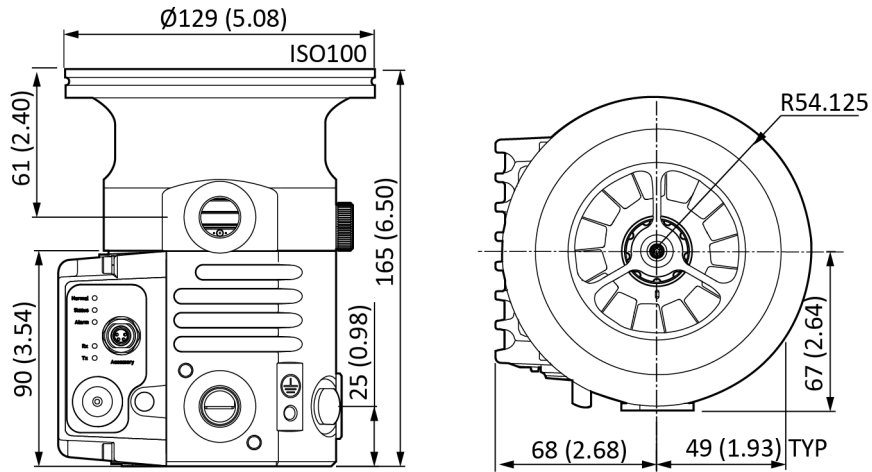

All measurements shown are in mm (inches)

Figure 4 Dimensions - nEXT85 DN40

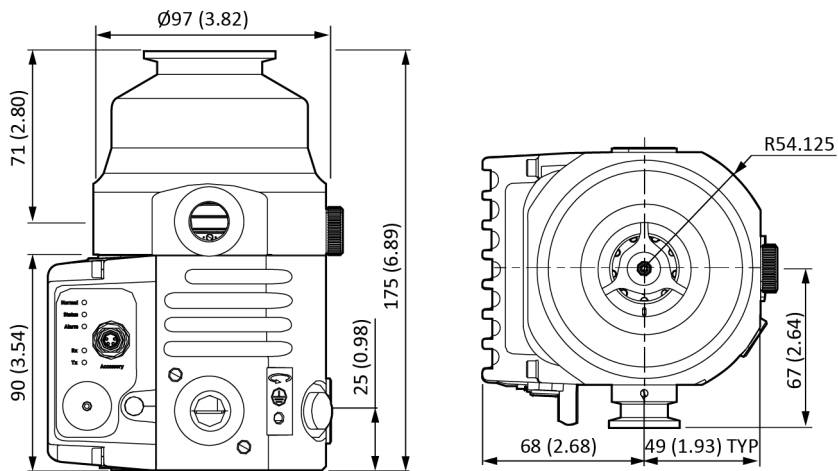

All measurements shown are in mm (inches)

Figure 5 Typical base view

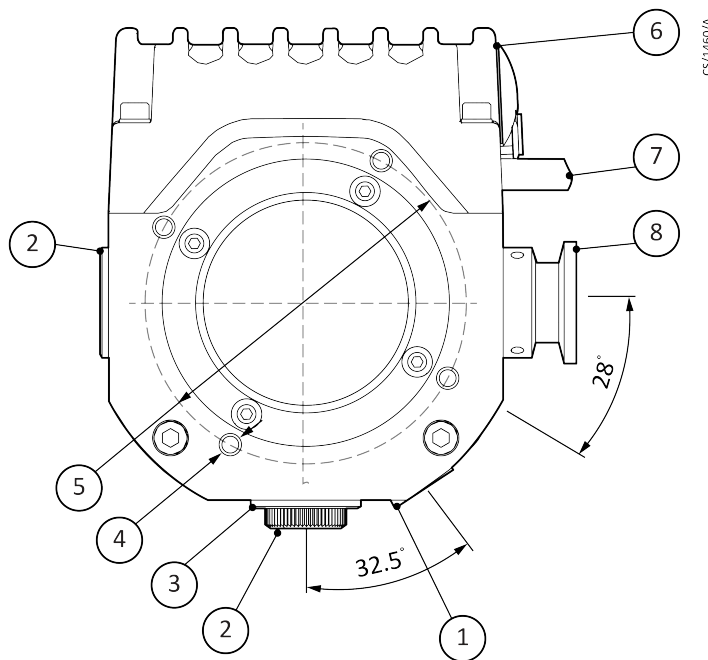

- | | |
|---|--------------------------------------|
| 1. Body purge port 1/8" BSP | 6. Electric drive |
| 2. Envelope vent port 1/8" BSP | 7. 24 V supply cable |
| 3. Alternative backing port position | 8. Backing port NW16 (Optional NW25) |
| 4. 4 x holes (M5 x 12 deep) Base mounting holes and fan mountings | |
| 5. 79 PCD mounting port | |

3.2 Operating and storage conditions

Table 2 Operating and storage conditions

Range	Data
Ambient operating temperature range	5 °C to 40 °C
Ambient operating humidity range	10% to 90% RH (non-condensing)
Maximum operating altitude	2000 m
Ambient storage temperature range	-30 °C to 70 °C

3.3 Vent gas specification and vent control data

The pump can be vented to atmosphere, but the high relative humidity of the air can increase the subsequent pump-down time. To decrease the pump-down times, vent with dry and clean gases. Refer to [Vent options, vent valve connection and control on page 68](#) for the vent options and the vent valve connection. Refer to [Controlled venting options on page 60](#) for configuring the venting options.

Table 3 Vent gas specification and vent control

Vent gas specification and control	Reference data
Vent gas	Dry air, nitrogen, argon or other inert gases

Vent gas specification and control	Reference data
Maximum dew point at an atmospheric pressure	-22 °C
Maximum size of particulates	1 µm
Maximum concentration of oil	0.1 parts per million
Recommended time for the rotational speed to reach 50%	> 15 seconds
Maximum permitted rate of increase of pressure	Refer to <i>Figure: Maximum allowed rate of increase in pressure during venting: pressure against time (pump initially at full speed) on page 21.</i>
Maximum permitted vent gas supply pressure	1 bar (gauge), 14.5 psig, 2×10^5 Pa

Figure 6 Maximum allowed rate of pressure rise during venting: pressure against time (with pump initially at full rotational speed)

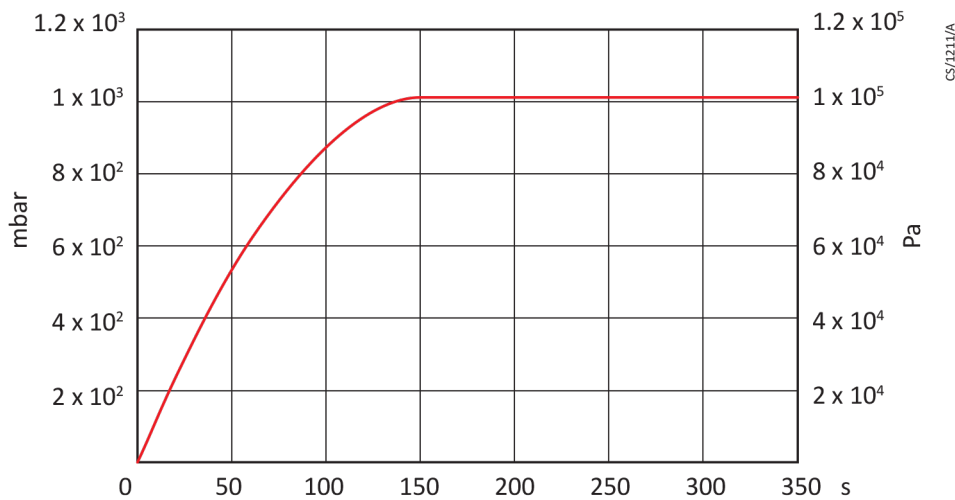

3.4 Purge gas specification

Table 4 Purge gas specification

Purge gas specification	Reference data
Purge gas	Dry air, nitrogen, argon or other inert gases
Maximum dew point at an atmospheric pressure	-22 °C
Maximum size of particulates	1 µm
Maximum concentration of oil	0.1 parts per million
Permitted purge gas flow (when necessary)	20 to 50 sccm (0.33 to 0.84 mbar l s ⁻¹ or 33 to 84 Pa l s ⁻¹)
Recommended purge gas flow	25 sccm (0.42 mbar l s ⁻¹ , 42 Pa l s ⁻¹)

Purge gas specification	Reference data
Maximum permitted supply pressure of the purge gas	1 bar (gauge), 14.5 psig, 2×10^5 Pa

3.5 Cooling water

Table 5 Water cooling block supply requirements

Parameter	Reference data
Quality	Mechanically and optically clear with no deposits or turbidity
pH value	6.0 to 8.0
Maximum calcium carbonate concentration	75 parts per million
Maximum chloride concentration	100 parts per million
Minimum oxygen concentration	4 parts per million
Minimum cooling water flow rate (at 15 °C)	15 l hr ⁻¹
Water temperature range	10 °C to 40 °C
Maximum water pressure	5 bar (gauge), 72.5 psig, 5×10^5 Pa gauge
Materials exposed to the cooling water	Nickel plated brass

Figure 7 Maximum relative humidity to avoid condensation with water cooling

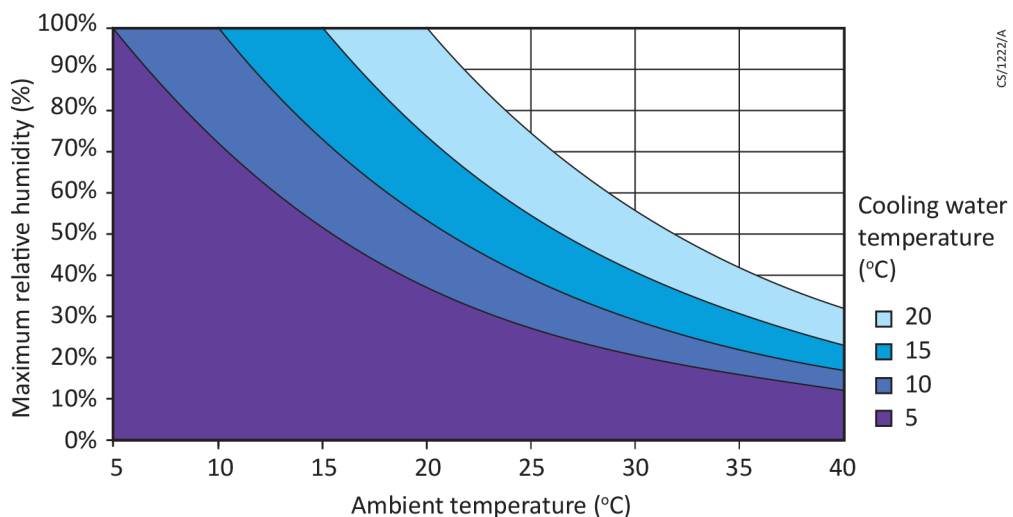

3.6 Electrical data

The nEXT pumps can be operated by the customer's system or by the manufacturer's TIC Turbo Instrument Controller, TIC Turbo Controller or TAG Controller.

If using the customer system, use an applicable, pre-approved, UL / CSA rated 24 - 48 V d.c. power supply. The size of the power supply depends on the application and the power limit configured in the nEXT pump. The rate of increase in the pump speed is dependent on the power limit setting. The power limit setting overrides the necessary

power supply setting. If serial communication is available, the power limit setting of the pump can be selected.

Refer to [Table: Logic interface technical data on page 25](#) for the maximum power limit settings for the pumps. If the rapid cycling of the pump is necessary for an application, you can get faster rate of increase in the pump speed if the power supply supplies higher current, up to a maximum in accordance with [Table: Logic interface technical data on page 25](#).

If the power limit setting is not adjustable, use a power supply capable to supply sufficient current to meet the manufacturer's factory default power limit setting shown in [Table: Logic interface technical data on page 25](#).

3.7 Pumping media



WARNING: DANGEROUS GASES

Risk of asphyxiation. Release the dangerous gases and gas mixtures safely. Do not expose people to the gases. Pump the hazardous gases or vapour as per safety recommendations given by supplier.



WARNING: PYROPHORIC OR EXPLOSIVE GASES

Risk of explosion. Do not use the nEXT pump to pump pyrophoric or explosive gas mixtures as the pump is not applicable for this purpose. The pump and its connections are not designed to contain an explosion.



WARNING: DANGEROUS GASES

Risk of damage to equipment. In the interstage and booster versions of the nEXT pumps, gas pumped through the interstage port will mix with gas pumped through the pump inlet. Make sure that the gases do not react or combine to form dangerous gases and substances.



WARNING: VACUUM EXPOSURE

Risk of injury. Do not expose the part of the human body to the vacuum.



WARNING: MERCURY VAPOUR

Risk of damage to equipment. Do not use a nEXT pump to pump mercury vapour. Do not allow mercury (for example, from a McLeod gauge) to come into contact with the pump. If mercury vapour is pumped, the pump rotor can corrode and fail.



CAUTION: CONDENSABLE GASES

Risk of damage to equipment. Do not use the pump to pump particulates or condensable media. Deposition can occur in the pump which will degrade the pump performance and decrease the pump life.



CAUTION: OXYGEN CONTENT IN GASES

Risk of damage to equipment. Do not use the pump to pump gases that contains more than 20% oxygen. This can cause the lubricant to polymerise and the pump can fail.

Note:

Concentrations of gases can be changed by the compression of the pump.

The pump is designed to pump the gases that follow:

- Air
- Carbon monoxide
- Neon
- Nitrogen
- Krypton
- Argon
- Carbon dioxide
- Helium
- Hydrogen

To pump a gas that is not listed, contact the supplier for advice. Failure to contact the supplier can invalidate the warranty of the pump. The pump is not applicable for pumping aggressive or corrosive gases.

Refer to the manufacturer's Vacuum Pump and Vacuum Safety manual P40040100 for safety information related with the specification, design and operation of vacuum pumps and vacuum systems.

The pump can be used to pump the oxygen and water vapour, with the conditions that follow:

- Oxygen - The oxygen concentration must be less than 25% by volume.
- Water vapour - Make sure that the water vapour does not condense in the pump.

3.8 Materials exposed to gases pumped

The materials and component types that are exposed to the gases pumped are:

- Aluminium alloys
- Stainless steels
- Fluoroelastomer and O-rings
- Hydrocarbon lubricant
- Felt
- Rare earth magnets
- Silicon nitride
- Titanium
- PTFE

3.9 Logic interface connector

The pump has a 15-way logic interface connector at the end of the logic interface cable. Use an applicable connector mating half (not supplied) to connect the nEXT pump to the customer equipment. Refer to the table that follows for the connector mating half type.

Table 6 *Logic interface technical data*

Logic interface item	
Connector*	15-way D-type male
nEXT pumps electrical supply:	
Permitted voltage range (with ripple)	24 V d.c. to 48 V d.c. +5%, -10% (21.6 to 50.4 V d.c.)
Maximum voltage ripple	0.5 V r.m.s.
Fuse rating	T6ALxxxV to T10ALxxxV for 24 V d.c. supply T4ALxxxV to T10ALxxxV for 48 V d.c. supply. Use an IEC/UL/CSA pre-approved fuse rated ≥ 60 V d.c.
Limit of power supply:	
Factory default setting	Refer to pump model on a product label
Maximum power limit	120 W
Minimum power limit	50 W
Precision of the power regulation	± 10 W
Start and serial enable control inputs:	
Enabled control voltage: low (close)	0 to 0.8 V d.c. (I _{out} = 0.55 mA nominal)
Disabled control voltage: high (open)	4 to 26.4 V d.c. (internal pull up to 6.4 V nominal)
Standby control input:	
Enabled control voltage: low (close)	0 to 0.8 V d.c. (I _{out} = 0.29 mA nominal)
Disabled control voltage: high (open)	4 to 26.4 V d.c. (internal pull up to 3.2 V nominal)
Analogue output:	
Output voltage	0 to 10 V d.c. (directly proportional to the measured parameter) Motor speed: 0 - 1500 Hz (0-100%) Motor power: 0 - 120 W Motor temperature: 0 - 100 °C Controller temperature: 0 - 100 °C Rotor temperature: 0 - 100 °C
Voltage precision	± 0.2 V
Output current	≤ 5 mA for specified precision
Normal status output:	

Logic interface item	
Type	Open collector transistor plus pull up resistor. Refer to Figure: Interface circuits for nEXT turbo pump controllers on page 27 .
< Normal speed (default 80%)	Off (2.2 k Ω pull up to 12 V d.c.)
\geq Normal speed	On (< 0.8 V d.c. sinking 20 mA)
Current rating	20 mA to 0 V
Voltage rating	28.8 V d.c. maximum external pull up voltage
Fail status output:	
Type	Open collector transistor plus pull up resistor. Refer to Figure: Interface circuits for nEXT turbo pump controllers on page 27 .
Fail	Off (3.3 k Ω pull up to 12 V d.c.)
OK	On (< 0.1 V d.c. sinking 1.7 mA, < 0.8 V d.c. sinking 20 mA)
Current rating	20 mA to 0 V
Voltage rating	28.8 V d.c. maximum external pull up voltage

* Mating half of connector not supplied.

Refer to the table that follows for the logic interface connector pins for the electrical connections.

Table 7 Logic interface connector pins

Pin Number	Signal	Polarity	Use
2	0 V Control reference	-	0 V reference for all control and status signals below.
3	START / STOP control input	-	Connect to Pin 2 to start pump
4	STANDBY control input / Serial RX / RS485 A-	-	Connect to Pin 2 to enable standby speed when serial enable is inactive and RS485 / RS232 switch is in the RS232 position.
5	Serial enable	-	Connect to Pin 2 to enable the serial link
7	FAIL / Serial TX / RS485 B+	-	Logic high when fail condition exists and serial enable is inactive and RS485 / RS232 switch is in the RS232 position.
9	Analogue output	Positive	0 - 10 V output proportional to measured output

Pin Number	Signal	Polarity	Use
10	Chassis / Screen	-	Screen
12	Chassis / Screen	-	-
15	NORMAL status output	-	Logic low when the rotational speed of the pump is at normal speed or above the normal speed
8, 13, 14	Electrical supply: 0 V	-	-
1, 6, 11	Electrical supply: 24 V - 48 V d.c.	Positive	-

Figure 8 Interface circuits for nEXT turbo pump controllers

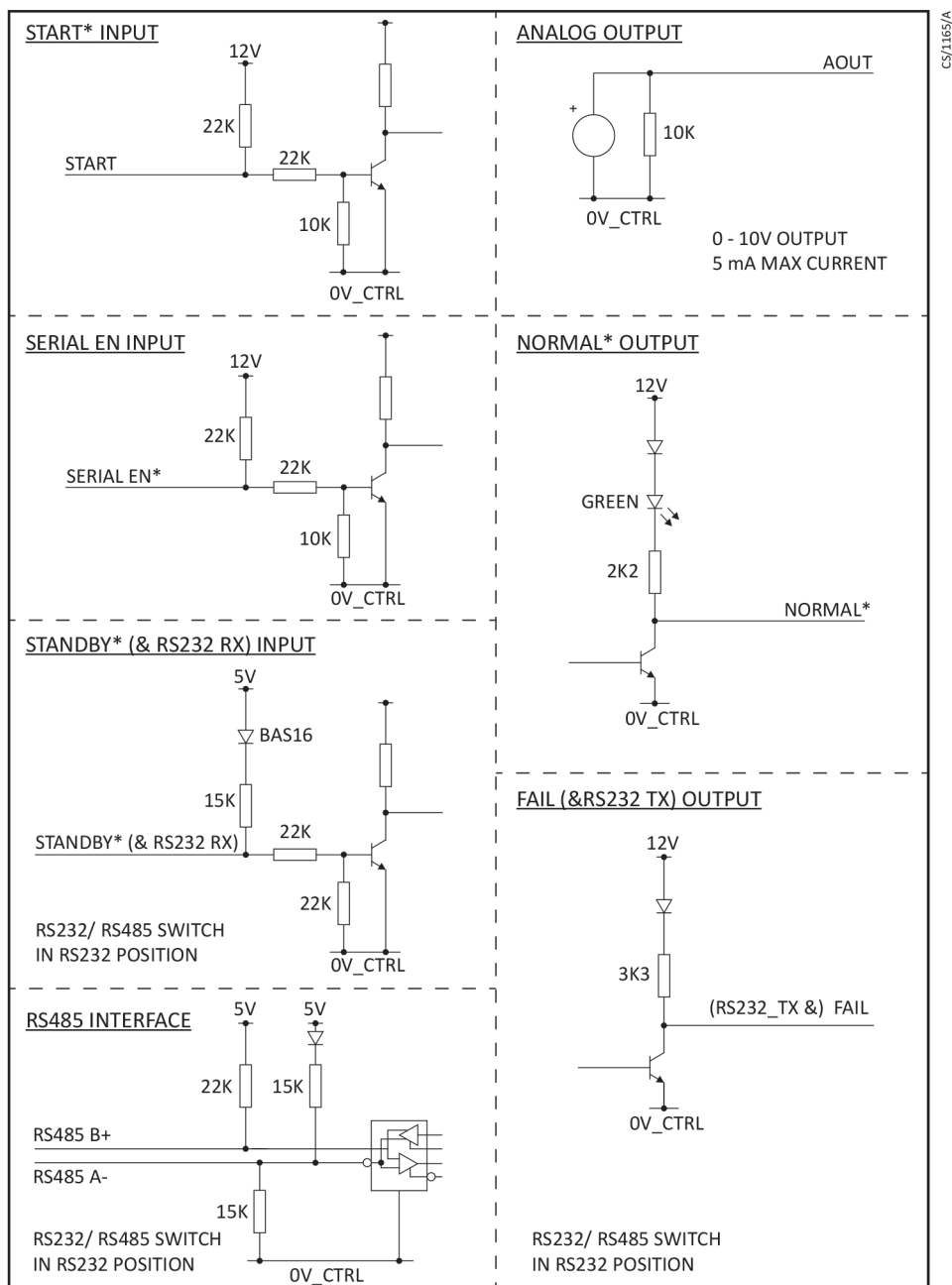

3.10 Motor controller auxiliary connector socket

The pump has a 4-way auxiliary connector socket at the side of the motor controller.

The mating plug for the connector is pre-installed to a number of accessories or available as an accessory. Refer to [Accessories on page 101](#).

The connector supplies the power to the vent valve or a fan. The connector is shown in [Figure: Valve connector on page 29](#), with the polarity of the pins marked, when the vent valve or fan is set to on.

The auxiliary connector output is controlled to 24 V d.c. to control the accessories, even when the pump is in operation from a 48 V d.c. supply and is protected from the overload and short circuits. If the auxiliary load current becomes more than the value given in [Table: Motor controller technical data on page 28](#), the output will stop to protect the motor controller.

Table 8 Motor controller technical data

Description	Data
Connector plug	Phoenix part number SACC-DSI-M 8FS-4CON-M12/0.5
Voltage output	24 V d.c. -25%, +10% (18 V d.c. to 26.4 V d.c.)
Current output	500 mA

The motor controller connector gives two independently configured and controlled outputs:

- Aux output 1
It is configured through the vent option 1 and valve 1 type. Refer to [Vent valve control on page 69](#).
Aux output 1 has default settings for a normally open vent valve.
- Aux output 2
It is configured through vent option 2 and valve 2 type. Refer to [Vent valve control on page 69](#).
Aux output 2 has default settings for a fan.

This enables the combination of fan or vent valve accessory to be connected, configured and controlled correctly.

The nEXT air coolers and vent valve accessories (which have the corresponding connector installed) are configured to Aux output 1 and Aux output 2 to give the plug and play ability (refer to [Accessories on page 101](#)). The nEXT vent valves are configured to Aux output 1 and the default setting for the vent options 1 are applicable for this type of accessory. The nEXT85 air coolers are configured to Aux output 2 and the default setting for the vent options 2 are applicable for this type of accessory.

Bare wire versions of the nEXT air coolers and vent valve accessories are available, which are not pre-configured. This enables any combination of accessory to be used, configured independently and controlled on Aux output 1 and Aux output 2.

Figure 9 Valve connector

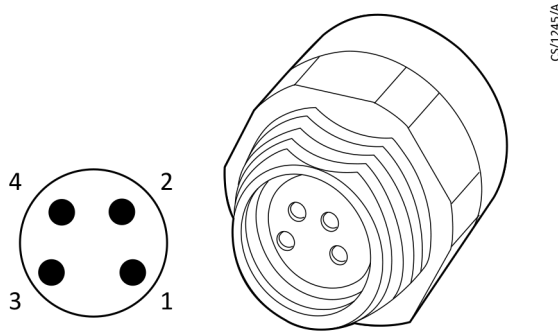

Pin number	Signal	Polarity
1	0V return	Negative
2	Aux output 1	Positive
3	Aux output 2	Positive
4	Chassis	Chassis

3.11 Indicator LEDs

The pump has five indicator LEDs. Refer to [Figure: Motor controller status information on page 46](#).

Table 9 Indicator LEDs

LED	Description
Normal LED	The green LED comes on when the rotational speed of the pump is more than the normal speed setting, irrespective of the acceleration or deceleration of the pump. The LED is duplicated at the sides of the pump.
Status LED	The yellow LED flashes with a 50% duty cycle at the rotational frequency of the pump motor. At high speeds it is continuously on. The LED sets to off when the rotational speed is very low or stopped. If the next service is available, the LED flashes in a sequence to show which service operation is necessary. Refer to Fault finding on page 86 . The LED is duplicated at the sides of the pump.
Alarm LED	The red LED flashes in a sequence to show an error code if a FAIL condition is preventing the pump operation. The error codes can be used for the fault finding as given in Fault finding on page 86 . The LED is duplicated at the sides of the pump.
Serial Communications Receive (Rx) LED	The yellow LED flashes when the activity is sensed on the serial link receive line. It can be used for the fault finding the serial link.
Serial Communications Transmit (Tx) LED	The yellow LED flashes when the motor controller transmits the data to the serial link transmit line. It can be used for the fault finding the serial link.

Note:

If an external electrical load is connected to the Normal output line, the normal LED can come on.

3.12 Pump performance data

Table 10 Pump performance data

Parameter	nEXT85D	nEXT85H	nEXT85D	nEXT85H	nEXT85D	nEXT85H	nEXT85D	nEXT85H
Mass	3.0 Kg	3.0 Kg	4.4 Kg	4.4 Kg	3.2 Kg	3.2 Kg	2.9 Kg	2.9 Kg
Main inlet port	ISO63	ISO63	CF63	CF63	ISO100	ISO100	NW40	NW40
Exhaust port	NW16							
Vent port	1/8 inch BSP							
Main inlet pumping speed:								
N ₂ (l s ⁻¹)	84	84	84	84	86	86	47	47
He (l s ⁻¹)	78	78	78	78	80	78	61	61
H ₂ (l s ⁻¹)	60	54	60	54	60	54	49	49
Ar (l s ⁻¹)	80	80	80	80	84	84	44	44
Peak compression ratio from the backing port to the main inlet port:								
N ₂	> 10 ¹¹							
He	8 x 10 ⁶	2 x 10 ⁷	8 x 10 ⁶	2 x 10 ⁷	8 x 10 ⁶	8 x 10 ⁶	8 x 10 ⁶	2 x 10 ⁷
H ₂	2 x 10 ⁵	5 x 10 ⁵	2 x 10 ⁵	5 x 10 ⁵	2 x 10 ⁵	5 x 10 ⁵	2 x 10 ⁵	5 x 10 ⁵
Ar	> 10 ¹¹							
Ultimate pressure (mbar)	< 5 x 10 ⁻⁹	< 5 x 10 ⁻⁹	< 5 x 10 ⁻¹⁰	< 5 x 10 ⁻¹⁰	< 5 x 10 ⁻⁹	< 5 x 10 ⁻⁹	< 5 x 10 ⁻⁹	< 5 x 10 ⁻⁹

Note:

Pumping speeds quoted are without inlet screens. Inlet screens may reduce the pumping speed by up to 20%. Pumping speeds are measured in accordance with ISO 5302:2003.

Figure 10 nEXT85 pumping speed versus inlet pressure performance graph

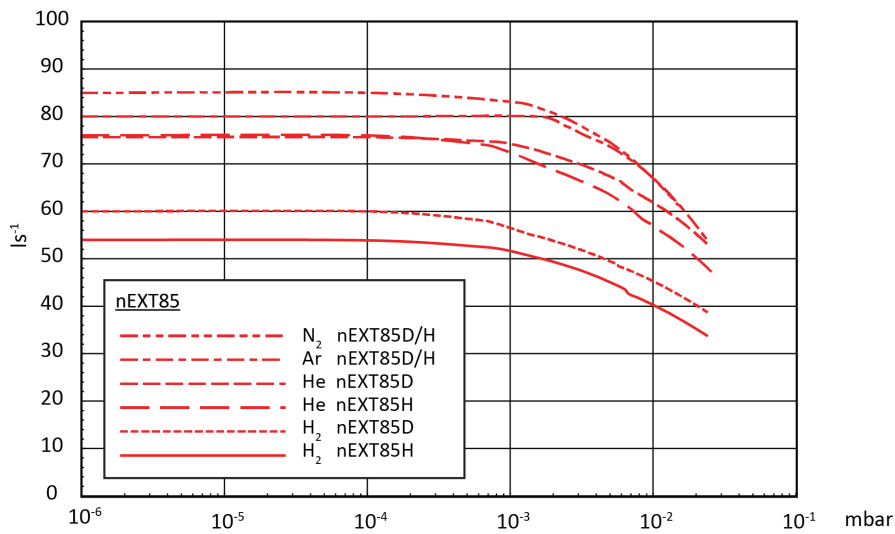

Figure 11 nEXT85 compression ratio versus backing pressure graph

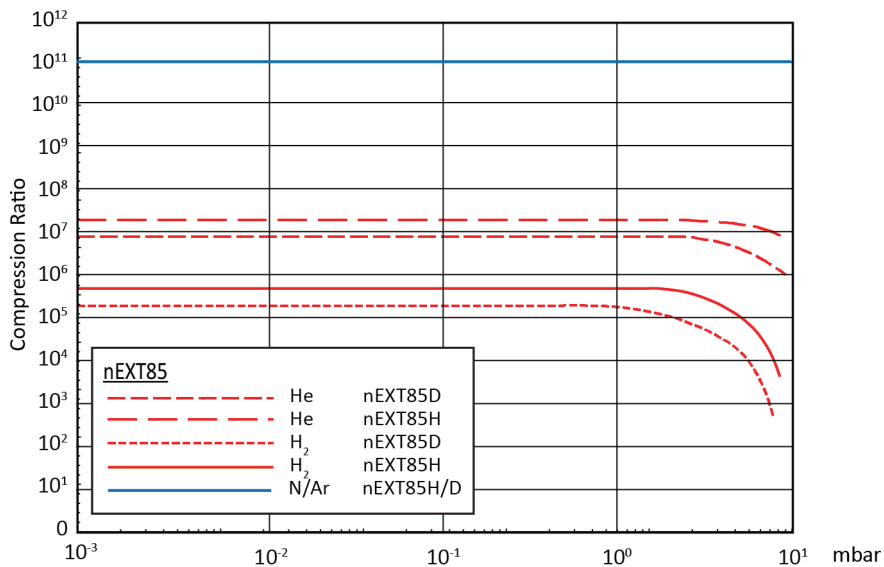

Table 11 Maximum transient backing pressure at zero inlet flow

Parameter	nEXT85D	nEXT85H
N_2	19 mbar	21 mbar
He	19 mbar	21 mbar
H_2	30 mbar	30 mbar
Ar	22 mbar	21 mbar

Maximum transient backing pressure is the pressure which can be sustained for a short time at 120 W.

Table 12 Maximum continuous backing pressure nEXT85D at zero inlet flow

Gas Type: N ₂			
Cooling method	Ambient Temperature		
	20 °C	30 °C	40 °C
	Backing Pressure (mbar)		
Natural convection	6	3.2	0.6
Force air cooling	18	14	11
Water cooling *	13	11.5	10

* Cooling water temperature of 15 °C at a flow rate of 15 l hr⁻¹

Values for maximum continuous backing pressure are taken under no inlet gas flow conditions, at sea level, in negligible magnetic field, with 120 W power limit setting.

Refer to [Cooling on page 55](#) for cooling conditions. At pressures above these, the rotational speed decreases below nominal.

Table 13 Maximum continuous inlet pressure/throughput nEXT85D - Nitrogen

Gas Type: N ₂						
Cooling method	Ambient Temperature					
	20 °C		30 °C		40 °C	
	Throughput (sccm)	Inlet Pressure (mbar)	Throughput (sccm)	Inlet Pressure (mbar)	Throughput (sccm)	Inlet Pressure (mbar)
Natural convection	15	3.6e-03	12	2.9e-03	7	1.6e-03
Force air cooling	95/80*	3.8e-02/ 2.9e-02 *	72	2.5e-02	37	1.0e-02
Water cooling [§]	50	1.5e-02	45	1.3e-02	40	1.1e-02

* Based on 80 W power limit setting

§ Cooling water temperature of 15 °C at a flow rate of 15 l hr⁻¹

Values for maximum continuous inlet pressure / throughput are taken using a nXDS20i backing pump, at sea level, in negligible magnetic field, with 120 W power limit setting.

Refer to [Cooling on page 55](#) for cooling conditions. At pressures above these, the rotational speed decreases below nominal. Values are given without inlet screen.

Table 14 Maximum continuous inlet pressure/throughput nEXT85D - Helium

Gas Type: He						
Cooling method	Ambient Temperature					
	20 °C		30 °C		40 °C	
	Throughput (sccm)	Inlet Pressure (mbar)	Throughput (sccm)	Inlet Pressure (mbar)	Throughput (sccm)	Inlet Pressure (mbar)
Natural convection	90	3.50E-02	60	2.00E-02	20	5.60E-03
Force air cooling	510/240 *	5.3e-01/ 1.5e-01*	475/240*	4.6e-01/ 1.5e-01*	235	1.50E-01
Water cooling [§]	270/240*	1.9e-01/ 1.5e-01*	200	1.10E-01	130	6.00E-02

* Based on 80 W power limit setting

[§] Cooling water temperature of 15 °C at a flow rate of 15 l hr⁻¹

Values for maximum continuous inlet pressure / throughput are taken using a nXDS20i backing pump, at sea level, in negligible magnetic field, with 120 W power limit setting.

Refer to [Cooling on page 55](#) for cooling conditions. At pressures above these, the rotational speed decreases below nominal. Values are given without inlet screen.

Table 15 Maximum continuous inlet pressure/throughput nEXT85D - Argon

Gas Type: Ar						
Cooling method	Ambient Temperature					
	20 °C		30 °C		40 °C	
	Throughput (sccm)	Inlet Pressure (mbar)	Throughput (sccm)	Inlet Pressure (mbar)	Throughput (sccm)	Inlet Pressure (mbar)
Natural convection	6.5	1.6e-03	5	1.2e-03	3	7.2e-04
Force air cooling	35	9.4e-03	25	6.4e-03	13	3.2e-03
Water cooling*	20	5.0e-03	18	4.5e-03	15	3.7e-03

* Cooling water temperature of 15 °C at a flow rate of 15 l hr⁻¹

Values for maximum continuous inlet pressure / throughput are taken using a nXDS20i backing pump, at sea level, in negligible magnetic field, with 120 W power limit setting.

Refer to [Cooling on page 55](#) for cooling conditions. At pressures above these, the rotational speed decreases below nominal. Values are given without inlet screen.

Table 16 General pump performance data

Parameter	Value
Recommended backing pump	nXDS15i

B8G000880_D - Technical data

Parameter	Value
Operation attitude	Vertical and upright to horizontal $\pm 2^\circ$
Normal rotational speed	90,000 revolutions per minute
Starting Time to 90% Speed (80 W)	130 seconds
Starting Time to 90% Speed (120 W)	90 seconds
Sound pressure level, at ultimate vacuum measured at 1 m from the pump to ISO3744	34 dB(A) + 2.5 declared dual number noise emission values in accordance with ISO4871

4. Installation

4.1 Unpack and inspect

The pump is supplied in a cardboard box and the lifting equipment is not necessary.



WARNING: HEAVY OBJECT

Risk of injury or damage to the equipment. Take necessary precaution when you lift and move the pump to prevent injury. Obey the manual handling guidelines.

Do not use the controller cable as a lifting device. Do not use the cable to lift or support the pump.



CAUTION: IMPACT ON ENVIRONMENT

Risk of damage to environment. When you install and remove of the pump, obey the local legislation about the impact of the pump on the environment.

1. Store the pump in its sealed bag until it is installed.
2. Be careful when you unpack the pump to prevent the excessive shocks. The excessive shocks can damage the bearings and decrease the life of the pump. The pump is supplied with sealed inlets and outlets to prevent the entry of dust and vapour.
3. Do not remove the seals until the pump is installed on the vacuum system.
4. Open the cardboard box from the top.
5. Open the box lid.
6. Remove the foam and open the bag.
7. Keep all the packing materials for use in inspection and in case the pump is returned for service.
8. If the pump is damaged, notify your supplier and the carrier immediately. Give the supplier and the carrier the information that follows:
 - part number of the pump
 - serial number of the pump
 - order number
 - supplier's invoice number
9. 1. Do not use the pump if the pump is damaged.
10. Check that the package has the items given in [Table: Checklist of items on page 35](#). If the items are missing, notify the supplier in writing in three days.
11. If the pump is not to be used immediately, store the pump in conditions as given in [Storage on page 95](#).

Table 17 Checklist of items

Quantity	Description	Check (✓)
1	nEXT Turbomolecular Vacuum Pump	<input type="checkbox"/>

Quantity	Description	Check (✓)
1	Integral mesh centring ring O-ring seal (ISO variants only. Screen will be installed to CF pumps.)	<input type="checkbox"/>

Figure 12 Typical pumping system with a nEXT pump

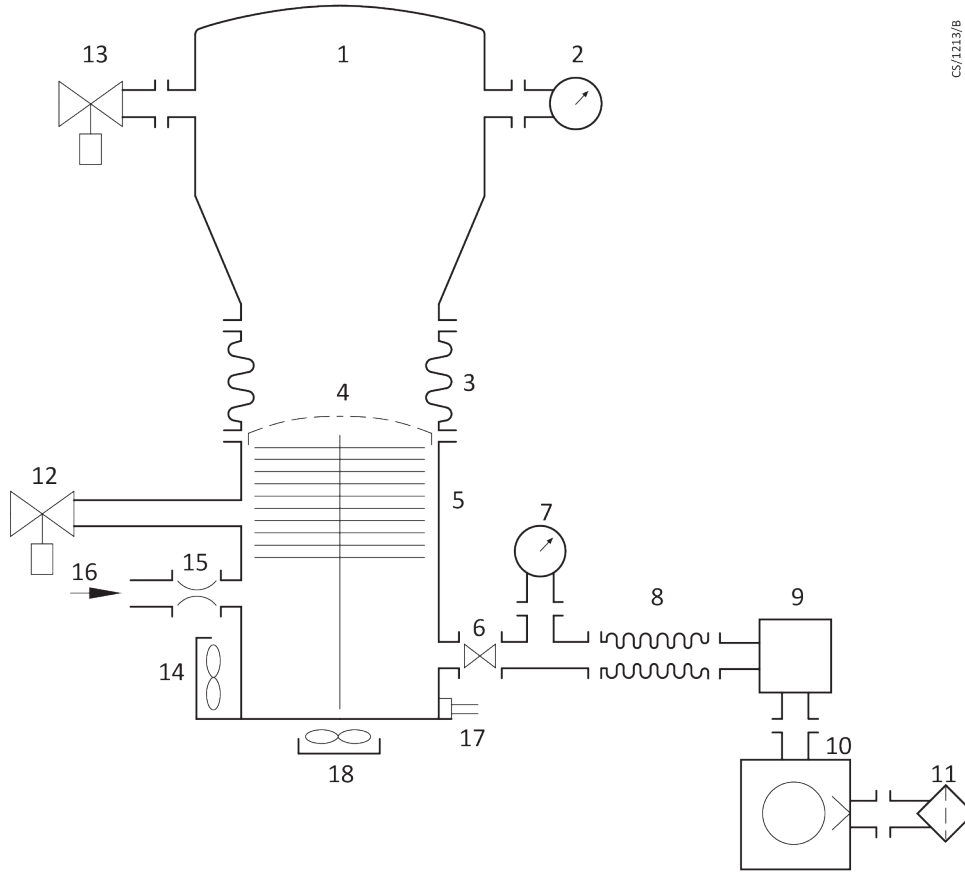

CS/1213/8

- | | |
|---|--------------------------------|
| 1. Vacuum system | 2. High vacuum gauge |
| 3. Vibration damper | 4. Inlet screen |
| 5. nEXT pump | 6. Backing valve |
| 7. Vacuum gauge | 8. Flexible bellows |
| 9. Foreline trap* | 10. Backing pump*§ |
| 11. Mist filter* / silencer§ | 12. Vent valve |
| 13. Alternative position for vent valve | 14. Radial air cooler |
| 15. PRX purge restrictor | 16. Regulated purge gas supply |
| 17. WCX water cooler and connections | 18. Axial air cooler |
| 19. | |

* for rotary pump

§ for scroll pump

Note:

An interstage port is available on the 'i' variant but is not shown in the figure.

4.2 Connect to the vacuum system



WARNING: INSTALLATION SEQUENCE

Risk of injury. Install the pump in the vacuum system before you connect the motor controller to the power supply so the pump cannot operate.



WARNING: TRIP HAZARD

Risk of injury and damage to equipment. Make sure that the cable and pipe work attached to the pump are carefully routed. Failure to do so can cause a slip or trip hazard and damage to the cable.

4.2.1 Remove and replace the inlet screen

The inlet screen is installed on the CF pumps only. Remove the inlet screen only if the debris cannot fall into the pump. If the inlet screen is removed, the pumping speed will increase by a maximum of 20%.



WARNING: SHARP OBJECT

Risk of injury. The rotor blades on the pump are sharp. Removal of inlet screens or strainers exposes the sharp edges or moving parts that can cause injury.



WARNING: FOREIGN OBJECTS INSIDE THE PUMP

Risk of damage to equipment. Make sure that there are no foreign objects inside the pump when you do the installation. Install the supplied integral mesh centring O-ring seal or the mesh screen when you install the pump.



WARNING: DEBRIS IN THE PUMP

Risk of damage to equipment. If the pump fractures and the inlet screen cannot trap all the debris, make sure that the system can contain the debris that escapes from the pump.



WARNING: INLET SCREEN

Risk of damage to equipment. The inlet screen is a coarse filter for debris and prevents contamination of the pump. Do not use the inlet screen as a finger guard or remove it until you are ready to mount the pump onto the system.

1. To remove the inlet screen from a pump with CF inlet flange, use a bent wire hook or a small screwdriver. Be careful when you remove the inlet screen out from the inlet flange.
2. To replace an inlet screen, put it centrally over the CF inlet flange.
3. Apply equal pressure with the fingers around the edge of the screen and push the inlet screen down.

If the inlet screen is not in an installed position, the tangs must be snapped into the locating groove in the inlet flange using an applicable tool to press them into position.

For ISO flanged pumps, we supply a combination inlet screen / trapped O-ring.

4.2.2 Mount the pump

The pump can be base or flange mounted using only the specified fixings. The NW40 inlet variant cannot be flange mounted.



WARNING: PUMP INSTALLATION

Risk of injury and damage to equipment. Make sure that the pump is installed at the vacuum system through its inlet flange or base. Use all available mounting points. If the pump fails, the stored energy of the rotor can cause fast movement of the pump. This will cause damage and injury to personnel.



WARNING: PUMP FAILURE

Risk of injury and damage to equipment. If a pump fails it is likely to eject parts into the vacuum system onto which it is mounted. The customer must make sure that a hazard is not created if this happens. We accept no responsibility for injury or damage to persons, equipment or property as a result of a failed pump ejecting parts into a customer's system.

- To mount the pump (base mount), use 4 x M5 bolts (Class 12.9) with 8 mm thread engagement.
- To mount the pump (flange mount), use 4 x Edwards Hooded Claw Clamps (C10007090) and tightened to 10 Nm.

Base mounting

The base of the pump can be fixed to a firm support using the tapped fixing holes.

Note:

Remove the four rubber feet from the four tapped fixing holes before you base mount the pump.

Obey the requirements that follow to make sure that the pump stays secured if the pump seizes:

Installation screws:	4 quantity of M5 to ISO898-1 strength class 12.9 (nominal tensile strength 1200 MPa)
PCD (Pitch Circle Diameter):	79 mm spaced equally. Refer to Figure: Typical base view on page 20 .
Screw engagement length:	8 mm
Fastening torque:	6 Nm (0.612 kgfm)

Inlet connection and pump orientation

The pump can be installed at the vacuum system through the inlet flange. Do not operate the pump in an orientation that is greater than horizontal.

CAUTION: PUMP ORIENTATION

Risk of damage to equipment. The pump must be orientated only in a horizontal or vertical position. Incorrect orientation can cause failure of the pump.

When you store the pump, the pump body has to be horizontally in line with or below the main inlet flange of the pump.

If the pump is operated or stored with the pump body above the main inlet flange, it can cause oil leakage from the reservoir at the base of the pump to the pump mechanism or to the vacuum system. This can decrease the performance of the pump and life of the bearing.

Refer to [Figure: Allowable pump orientation on page 40](#) for permitted pump orientation.

Make sure that the pump inlet and all components installed to the pump inlet are clean and dust-free. Failure to do so can increase the pump-down time.

The inlet connections for the pumps are of ISO flange, CF flange or NW40 flange.

- If the pump has a CF flange, use the copper compression gasket supplied with the pump. Use all supplied bolts to connect the inlet flange of the pump to the vacuum system. A minimum grade screw of ISO898-1 class 5.6 (500 MPa tensile strength) is recommended.
- If the pump has an ISO flange, use a manufacturer's combination inlet screen / trapped O- ring supplied with the pump. Use minimum four claw clamps (each torqued to 10 Nm) to connect the inlet flange of the pump to the vacuum system.
You can also use a rotatable collar and the combination inlet screen and trapped O-ring supplied with the pump to connect the inlet flange of the pump to the vacuum system. Use all supplied bolts of minimum ISO class 5.6 (torqued to 10 Nm) with the rotatable collar for the installation.

If the pump has an NW flange, use the centring ring supplied with the pump and a metal NW clamp to connect the inlet flange of the pump to the vacuum system. Install the base of the pump to a rigid support as given in [Base mounting on page 38](#).

Tighten all inlet flange bolts again when the system is under vacuum. Make sure that torques or other forces are not transmitted to the pump from the vacuum system or the related pipelines.

Figure 13 Allowable pump orientation

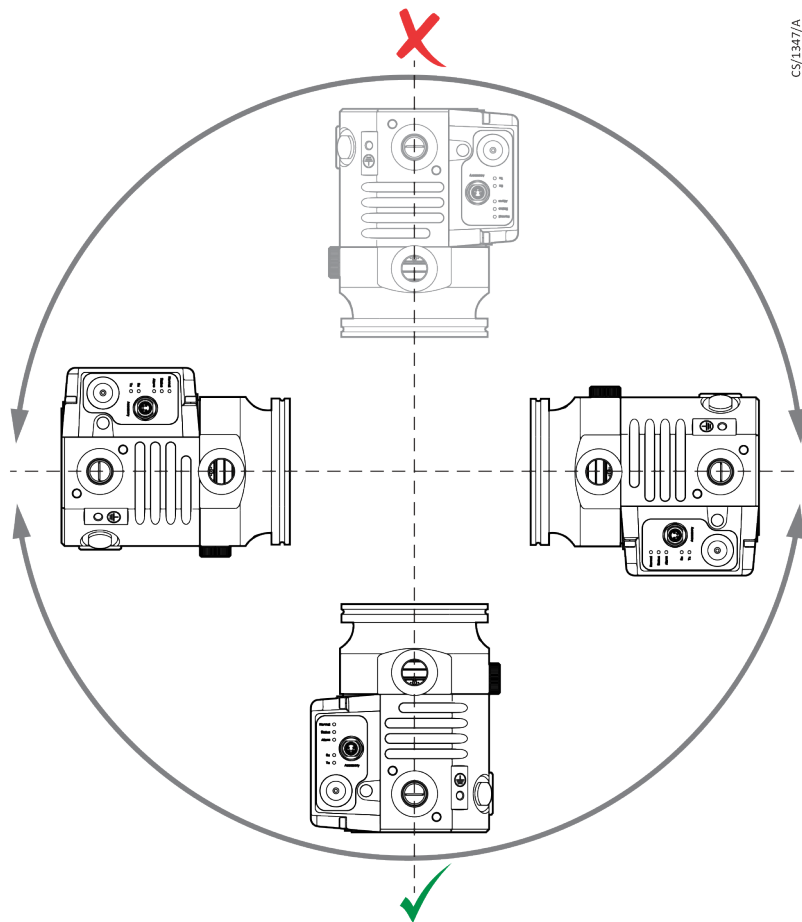

4.2.3 Backing port connection

The pump is applicable to use with our rotary vane, scroll or diaphragm backing pumps. System performance can change with the type of pump used. Contact us to select an applicable backing pump for the application.



WARNING: PUMP OVER-PRESSURE

Risk of injury or damage to equipment. To prevent over-pressure in the pump, do not limit the exhaust line when you vent from a positive pressure gas supply.



CAUTION: BEARING LIFE

Risk of damage to equipment. Do not use the pump with a backing pressure less than 5×10^{-4} mbar (5×10^{-2} Pa). Lower backing pressures increases the evaporation rate of the lubrication oil and can decrease the life of the bearings.



WARNING: UNSAFE DUCTING

Risk of injury or damage to equipment. Make sure that the ducting of the backing line is safe to prevent leakage of oil mist or hazardous substances.

Use applicable vacuum tubing and connectors to connect the NW25 flange of the backing port to the backing pump. If necessary, use flexible pipe or bellows to decrease the transmission of the vibration from the backing pump to the pump.

4.2.4 Interstage connection

An interstage connection is only possible using an 'i' nEXT pump to back the other pump.

1. Use applicable vacuum tube and connectors to connect the interstage port to the vacuum system or to the outlet flange of the other turbo or compound turbomolecular pump.
2. Keep the inlet strainer in the interstage port only if you are sure that debris cannot enter into the interstage port.

4.3 Purge gas connection

4.3.1 Recommended purge gas flow

The recommended purge gas flow for typical applications is 25 sccm ($0.42 \text{ mbar l s}^{-1}$, 42 Pa l s^{-1}). The flow protects the pump when you pump the oxygen in concentrations more than 20% by volume.

The flow rate of the purge gas must be in a range given in [Purge gas specification on page 21](#). To limit the flow rate, use a flow controller or a pressure regulator and calibrated flow restrictor. The PRX10 purge restrictor accessory is applicable for the purpose. Refer to [Accessories on page 101](#).

4.3.2 Connect the purge gas

 **Note:**

The purge gas must comply with the specification given in [Purge gas specification on page 21](#).

1. To supply the purge gas to the pump, remove the plug installed in the purge port.
2. To install a vent port adaptor, refer to [Accessories on page 101](#).
3. Connect the purge gas supply to the vent port adaptor.

4.4 Electrical installation



WARNING: ELECTRICAL INSTALLATION

Risk of injury or damage to equipment. Make sure that the electrical installation of the pump is in accordance with the regional and local codes and conforms to local and national safety requirements. The pump must be connected to an applicable power supply unit with an applicable earth (ground) point.

Make sure that qualified persons do the electrical installation. Do the electrical connections of the pump after the pump is installed on the vacuum system.

Do not remove the motor controller from the pump. The motor controller does not have user-serviceable parts.

You can operate the pump using the manufacturer's TIC Turbo Instrument Controller, TIC Turbo Controller, TAG Controller or by the customer supply and controlled using the customer system. Refer to [Connect the logic interface to the control equipment on page 42](#) for information about control. Refer to [Connect the electrical supply on page 43](#) for instructions on how to connect the electrical supply.

4.4.1 Ground the connections

We recommend you to install a separate ground conductor to ground the pump.

Ground the pump using the given connection. Refer to [Figure: Dimensions - nEXT85 ISO63 on page 18](#), [Figure: Dimensions - nEXT85 CF63 on page 19](#), [Figure: Dimensions - nEXT85 ISO100 on page 19](#) and [Figure: Dimensions - nEXT85 DN40 on page 19](#).

Use the braided wire that is not insulated or a separate insulated green / yellow connector, an M5 x 10 screw and shake proof washer supplied (installed to the ground hole of the pump) to install the ground connector to the pump. The size and rating of the ground conductor has to be sufficiently large to protect against other equipment in the customer system. The impedance between the pump body and the ground connection point must be $< 0.1 \Omega$.

4.4.2 Connect the logic interface to the TIC or TAG

If the manufacturer's TIC Turbo Instrument Controller, TIC Turbo Controller or TAG Controller is used to power and control the pump, connect the pump logic interface cable into the back of the TIC or TAG. Refer to the TIC or TAG Instruction Manuals for more information.

If the TIC or TAG is to be used to control the pump, make sure that the RS485 / RS232 slide switch is in the RS232 position. Refer to [Connect the serial interface to the customer control equipment on page 45](#). If the switch is in the RS485 position:

- the TIC will connect to the pump in a parallel mode (that shows the pump type as nEXTp)
- the serial connection is disabled
- start and stop is possible
- the TAG will not connect to the pump or control the pump.

4.4.3 Connect the logic interface to the control equipment

If you use your own control system to operate the pump, use an applicable connector mating half (not supplied) to connect the control equipment to the connector on the logic interface cable.

Refer to [Table: Logic interface connector pins on page 26](#) for the details of the logic interface connector pins, when you do the electrical connections to the pump.

Refer to [Table: Logic interface technical data on page 25](#).

Connect the electrical supply



WARNING: POWER SUPPLY

Risk of electric shock or damage to equipment. A separate power supply (not included) is necessary for the product. The power supply has to be protected against a hazardous live condition (for example, a short circuit).



WARNING: EMERGENCY STOP SWITCH

Risk of injury or damage to equipment. Install an applicable emergency stop switch in the electrical supply. Make sure that the switch is easy to access and is marked as the emergency disconnecting device for the pump. Failure to do so can cause you to not be able to switch off the pump in an emergency.



WARNING: HOT SURFACE

Risk of injury or damage to equipment. Install an applicable fuse or current limiting device in the 24 - 48 V d.c. supply line to the pump. Failure to do so can cause the hazardous surface temperature of the pump or risk of a fire hazard. Refer to [Table: Logic interface technical data on page 25](#) for applicable fuse ratings.



WARNING: SUPPLY VOLTAGE

Risk of injury or damage to equipment. Make sure that the maximum supply voltage is not more than necessary voltage. Failure to do so can cause permanent damage to the control electronics and can cause a mechanical hazard in failure conditions.



WARNING: HOT SURFACE

Risk of injury or damage to equipment. When you connect the pump to the power supply, make sure that all 3 pins for the 24 - 48 V connection and all 3 pins for the 0 V connection on the customer connector mating half are connected to the power supply. Failure to do so can cause the connectors to overheat .

The electrical supply for the pump must meet the requirements of UL61010-1 and EN61010-1. Make sure that the hazardous voltages given in UL61010-1 and EN61010-1 are not available on the electrical interface to the pump.

The pump 0 V is not referenced to ground. Make sure that there is only one path between 0 V and ground. Do not make multiple connections between 0 V and ground to prevent the offset voltages on control and status signals and problems with serial communications. If there is no connection available between 0 V and ground, make the connection at the power supply. Other electrical equipment connected to the system can make a connection between 0 V and ground, for example a personal computer or a measuring equipment.

4.5 Connect the parallel control and monitoring

To make the connections for the parallel control and monitoring, use an applicable mating half (not supplied).



CAUTION: BACK EMF SUPPRESSION DIODE

Risk of damage to equipment. If the normal and fail lines are used to drive the coils of the d.c. relays, install a back EMF suppression diode in parallel with each relay coil to protect the pump.

Connect the customer control equipment to the control input pins of the customer logic interface mating half. Refer to [Table: Logic interface connector pins on page 26](#) to identify the connector pins of the logic interface.

The control inputs are:

- Start
- Standby speed

To activate one of the control inputs, connect the control input pin to the 0 V control reference. To start the pump, connect the pin 3 (Start / Stop) to the pin 2 (0 V reference). To stop the pump, remove the connection between the pin 3 and pin 2. To put the pump in standby, connect the pin 4 (Standby) and pin 3 (Start / Stop) to pin 2 (0 V reference).

Note:

Serial enable is also a control input, it is not necessary in a system that operates under parallel control. Make sure that there is no connection to the serial enable (pin 5).

Note:

To use the standby or fail parallel interface signals, make sure that the RS485 / RS232 slide switch is in the RS232 (default) position. Refer to [Connect the serial interface to the customer control equipment on page 45](#).

1. To monitor an analogue output, connect the customer control equipment to the pump analogue output (pin 9) and to the pin 2 of the customer logic interface mating half.
When the pump is shipped, the analogue output is configured to monitor the rotational speed of the pump. To monitor other parameters, configure the pump again using the commands over the serial interface. Refer to [Connection for serial control and monitoring on page 45](#) for more information.
2. To monitor the normal status output, connect the customer control equipment to the normal status output (pin 15) and to the pin 2 of the customer logic interface mating half.
You can use the output to control other devices in the pumping system. The output can operate a low power relay of up to 24 V d.c. coil rating (up to 20 mA).
3. To monitor the fail status output, connect the customer control equipment to the fail output (pin 7) and to the pin 2 of the customer logic interface mating half.
You can use the output to control other devices in the pumping system. The output can operate a low power relay of up to 24 V d.c. coil rating (up to 20 mA).

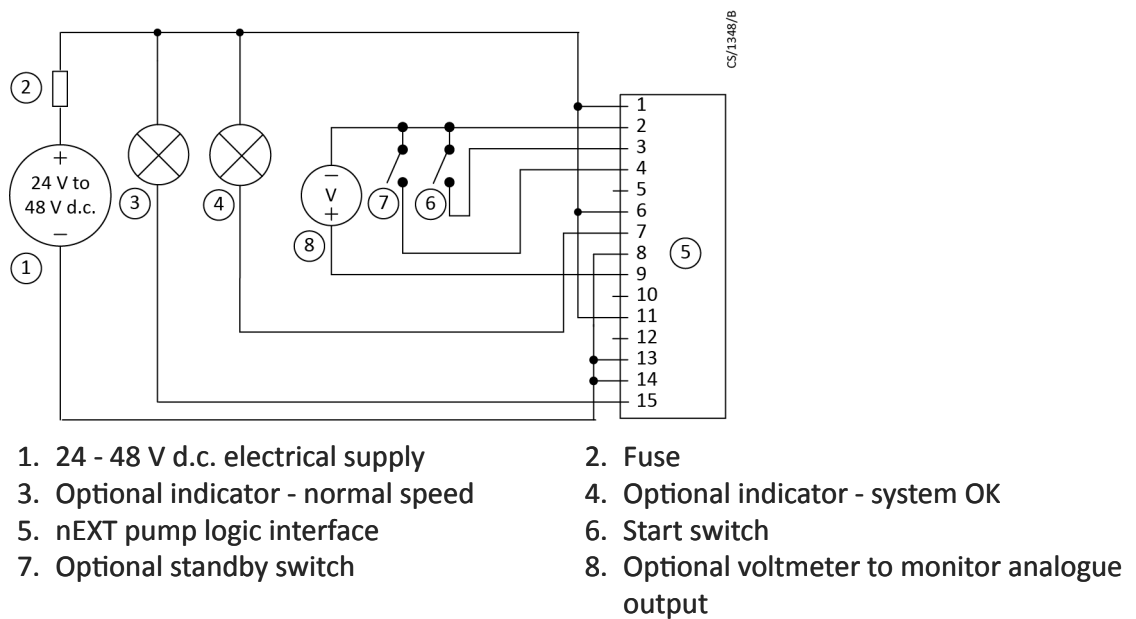
Figure 14 Logic interface connections - parallel control

4.6 Connection for serial control and monitoring

In the serial interface, the pump is controlled through a number of serial commands or the nST PC software. You can also check the operational status in the serial interface. In the multi-drop mode, connection of more than one pump to a single serial port on the control system is possible.

4.6.1 Connect the serial interface to the customer control equipment

The serial interface is available in RS485 or RS232 options. Use the slide switch (given adjacent to the main power lead) to select the serial interface (refer to [Figure: Motor controller status information on page 46](#)). To adjust the slide switch, use a small tool to toggle the slide switch. The default setting of the motor controller is RS232 serial interface. Replace the round seal to make sure the pump stays IP rated.

CAUTION: PUMP GROUND CONNECTION



Risk of damage to equipment. When you connect the pump to a PC, the 0 V pin on the RS232 connector can be connected to the ground through the PC. Make sure that the 0 V rail of the 24 - 48 V d.c. supply is not connected to the ground at other point (example, at the power supply). If the 0 V rail of the 24 - 48 V d.c. supply will not be connected to the ground at the PC, use an opto-isolated interface to the PC.

The pump can connect to the RS485 or RS232 serial input on the control equipment or a PC as shown in [Figure: Logic interface connections - RS232 serial control on page 46](#) and [Figure: Logic interface connections - RS485 serial control on page 47](#). In given configuration, the PC is the serial link master and the pump is the slave. The distance over which the serial link will work is dependent on the difference in voltage between the 0 V at the sending and receiving end. If the 0 V reference at the receiving end is in 0.3 V of the 0 V control reference pin on the pump control connector, then the serial link has to be capable to operate at a distance up to 6 m. For longer distances, an interface circuit external to the pump can be necessary.

The software in the pump can operate with the other pumps connected to a single serial link master. This is a multi-drop mode. The RS485 option is recommended for the multi-drop mode. When the RS232 option is selected, more hardware is necessary to link number of pump units to a single serial link master. A concept drawing of one possible arrangement is shown in [Figure: Conceptual diagram for multi-drop connection using RS232 interface on page 53](#). When the RS485 option is selected, it is easy to connect number of pumps to a single master. Refer to [Figure: RS485 multi-drop connection on page 54](#).

Figure 15 Motor controller status information

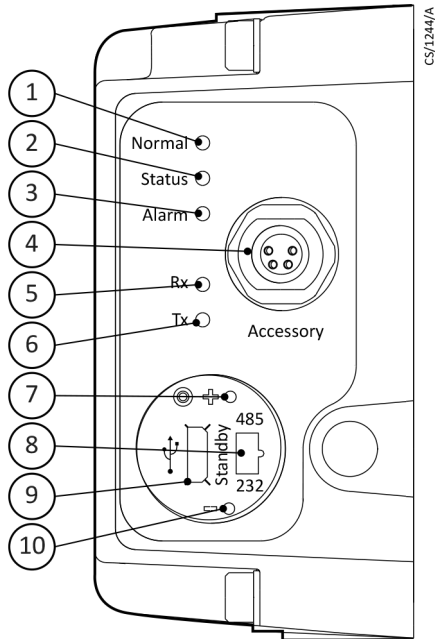

- | | |
|----------------------------------|-----------------------------------|
| 1. Normal LED | 2. Status LED |
| 3. Alarm LED | 4. Accessory connector |
| 5. Serial receive LED | 6. Serial transmit LED |
| 7. Standby speed increase button | 8. RS232 / RS485 slide switch |
| 9. USB connector | 10. Standby speed decrease button |

Figure 16 Logic interface connections - RS232 serial control

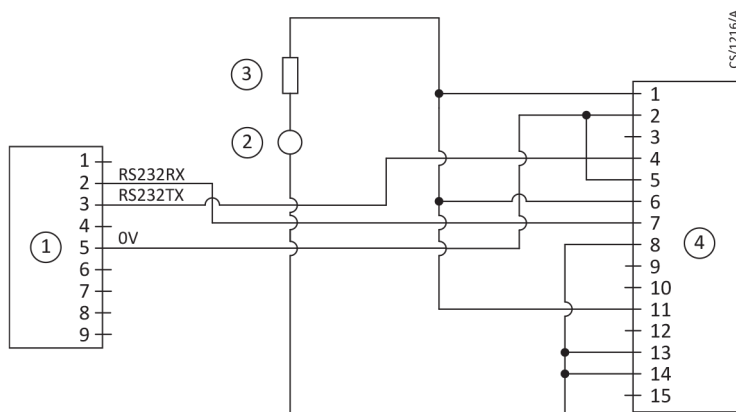

- | | |
|---|-------------------------------------|
| 1. RS232 interface on control equipment | 2. 24 - 48 V d.c. electrical supply |
| 3. Fuse | 4. nEXT pump logic interface |

Figure 17 Logic interface connections - RS485 serial control

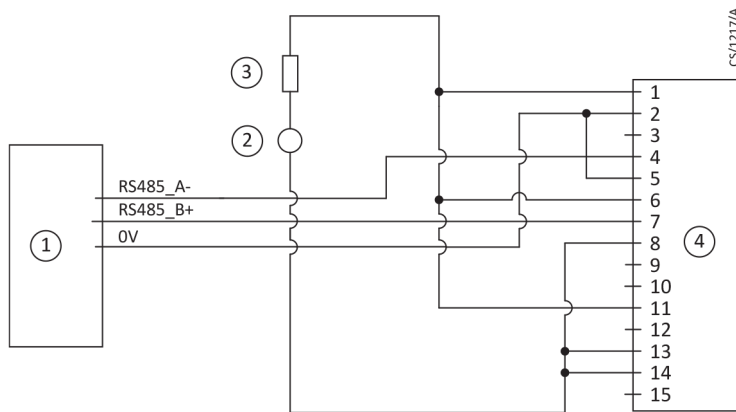

- 1. RS485 interface on control equipment
- 2. 24 - 48 V d.c. electrical supply
- 3. Fuse
- 4. nEXT pump logic interface

4.6.2 Serial enable

To send a serial message over the serial link, activate the serial enable. To activate the serial enable, link the serial enable input signal (pin 5) to pin 2 of the customer logic interface mating half.

We recommend you to incorporate this link into the serial communications cable so that the serial enable is activated only when the serial cable is connected. When the cable is removed, serial enable will become inactive.

Serial enable operates as an interlock for the start commands sent over the serial interface. If the pump operates in serial control mode (having been sent a serial start command) and the serial enable becomes inactive, the pump will trigger a fail condition and will decelerate and stops. To clear the fail condition, activate the serial enable again and send a serial stop command.

4.6.3 Serial protocol

The serial interface link is set to 9600 Baud, 8 bits, 1 stop, no parity with no handshaking. The commands are made from printable ASCII characters. The maximum message size that can be sent is 80 characters, with start and end characters.

Note:

All alphabetical characters must be sent in upper case format. The response can have lower case characters.

Each complete command message sent will receive one of the responses: a status code or a data return. The pump can only process with one message at a time. The nEXT pump will only accept a new message when the response to the previous message has been returned.

If the pump receives characters that are not framed in the start and stop characters, the pump will ignore them. Messages with the missing stop character will be discarded with no response when a new start character is received. If the pump receives an unrecognisable message between the start and stop characters, it will return an applicable error message.

Refer to [Multi-drop operation on page 52](#) for more information about how to operate the pump in a multi-drop mode.

4.6.4 Command set

Table 18 Summary of commands that can be sent to the pump

Object name	Command	Parameter range	Factory setting	Data type	Units	Comments
Node	!S850	0..99	-	decimal	address	Multi-drop address
	?850					0 = disable multi-drop address
						99 = wild card
Pump type	?S851	8	-	string	chars	Pump type
		10	-	string	chars	DSP software version number
		4	-	string	chars	(D39659610) Full speed RPS (1500 for nEXT85)
Pump control	!C852	0	-	decimal	-	Stop the pump
		1				Start the pump
	?V852	0..1800	-	decimal	RPS	Measured motor speed
		32-bits		hex	flags	System status word
Time setting	!S854	1..30	8	decimal	minutes	Timeout period for both initial ramp up and if speed decreases below 50%
	?S854	-	-	-	-	-
Power limit setting	!S855	50..120	80	decimal	Watts	Link power maximum
	?S855	-	-	-	-	-
Normal speed setting	!S856	50..100	80	decimal	%	Normal speed as a percentage of full speed
	?S856	-	-	-	-	-
Standby speed setting	!S857	55..100	70	decimal	%	Standby speed as a percentage of full speed
	?S857	-	-	-	-	-
Temperature readings	?V859	0..100	-	decimal	°C	Measured motor temperature
		0..100		decimal	°C	Measured motor controller temperature
Link parameter readings	?V860	0..500	-	decimal	0.1 Volts	Measured link voltage
		0..300		decimal	0.1 Amps	Measured link current
		0..15000		decimal	0.1 Watts	Measured link power

Object name	Command	Parameter range	Factory setting	Data type	Units	Comments
Pump run hours	?V862	0..65535	-	decimal	hours	Hours run by pump
Temperature readings 2	?V865	-200..200	-	decimal	°C	Measured motor temperature
		-200..200		decimal	°C	Measured motor controller temperature
		-200..200		decimal	°C	Measured rotor temperature
Factory settings	!S867	1	-	-	-	Reset all configuration options and parameters to the factory settings
PIC software version	?S868	10	-	string	chars	Boot loader software version number (D396596XXX)
Speed control	!C869	0	-	decimal	-	Set target speed to full speed
		1	-	-	-	Set target speed to standby speed
Timer options	!S870	0	1	decimal	-	Timer = disabled
	?S870	1	-	-	-	Timer = enabled Note that the timer is permanently enabled on ramp-up.
Analogue signal options	!S871	0	0	decimal	-	Analogue output = measured speed
	?S871	1			-	Analogue output = measured power
		2				Analogue output = measured motor temp.
		3				Analogue output = measured control temp.
		4				Analogue output = measured rotor temp.
Electronic braking options	!S872	0	0	decimal		Electronic braking = disabled
	?S872	1				Electronic braking = enabled. Refer to Electronic braking on page 14.

Object name	Command	Parameter range	Factory setting	Data type	Units	Comments
Close vent valve	!C875	1	-	decimal	-	Closes the vent valve for delayed start and overrides the current vent option. There is no open vent valve command but the stop command (!C852 0) will clear the override.
Valve 1 type	!S877	0	0	decimal	-	Normally Open Valve
	?S877	1				Normally Closed Valve (power cycle is required)
Valve 2 type	!S878	0	0	decimal	-	Normally Open Valve
	?S878	1				Normally Closed Valve (power cycle is required)
Service status	?V881	32 bits	-	hex	flags	Service status word
Controller run time	?V882	0..999999	-	decimal	hours	Hours run by controller
		0..999999		decimal	hours	Hours until controller service due
Pump run time	?V883	0..999999	-	decimal	hours	Hours run by pump
		0..999999		decimal	hours	Hours until pump service due
Pump cycles	?V884	0..65535	-	decimal	cycles	Cycles run by pump
		0..65535		decimal	cycles	Cycles until pump service due
Bearing run time	?V885	0..999999	-	decimal	hours	Hours run by bearing
		0..999999		decimal	hours	Hours until bearing service due
Oil cartridge run time	?V886	0..999999	-	decimal	hours	Hours run by oil cartridge
		0..999999	-	-	-	
		0..999999	-	decimal	hours	Hours until oil cartridge service due

Object name	Command	Parameter range	Factory setting	Data type	Units	Comments
Vent options 1	!S853	0	0	decimal		Hard vent when < 50% speed if stop or fail
	?S853	1			Controlled vent if > 50% speed then hard vent if	
					< 50% speed if stop or fail	
		2			If stop, hard vent If fail, hard vent when < 50% speed	
		3			If stop, hard vent If fail, controlled vent > 50% speed then hard vent < 50% speed	
		4			If fail, hard vent	
					If stop, hard vent when < 50% speed	
		5			If fail, hard vent If stop, controlled vent > 50% speed then hard vent < 50% speed	
		6			Hard vent if stop or fail	
		7			Same as option 6	
		8			Output is permanently energised (Fan ON)	
		9			Do not use	
		10			Output is permanently de-energised (Fan OFF)	
		11			Do not use	
		12			Do not use	
13		Do not use				
14		Hard vent when < 50% speed if stop				
		15		Controlled vent if > 50% speed then hard vent if < 50% speed if stop		

Object name	Command	Parameter range	Factory setting	Data type	Units	Comments
Vent options 2	!864	0	8	decimal		Hard vent when < 50% speed if stop or fail
	?864	1				Controlled vent if > 50% speed then hard vent if < 50% speed if stop or fail
		2				If stop, hard vent If fail, hard vent when < 50% speed
		3				If stop, hard vent If fail, controlled vent > 50% speed then hard vent < 50% speed
		4				If fail, hard vent If stop, hard vent when < 50% speed
		5				If fail, hard vent If stop, controlled vent > 50% speed then hard vent < 50% speed
		6				Hard vent if stop or fail
		7				Same as option 6
		8				Output is permanently energised (Fan ON)
		9				Do not use
		10				Output is permanently de-energised (Fan OFF)
		11				Do not use
		12				Do not use
		13				Do not use
		14				Hard vent when < 50% speed if stop
15		Controlled vent if > 50% speed then hard vent if < 50% speed if stop.				

4.6.5 Multi-drop operation

With multi-drop mode, a single computer system can communicate with more than one pump. Each pump must be assigned its own individual address before it can be installed in a multi-drop system. The command to assign the multi-drop address is sent in standard nEXT message format. Refer to [Assigning a multi-drop address on page 64](#).

The message protocol in the multi-drop mode is different than the protocol given for the serial messages in the single pump systems. The differences in the multi-drop message protocol are:

- All multi-drop commands, queries or replies have the first character as #.
- All commands, queries and replies have a header that has:
 - the address of the node that the message is to
 - the address of the node that the message is from
- Delimiter character: (colon) which separates the two multi-drop addresses in the header
- The remaining message (command, query or reply) obeys the same protocol as given for the single pump systems.
- The wild card address 99 is useful which means 'any' node.

After a pump has been assigned a multi-drop address, it will ignore the messages in the format for the single pumps. An individual pump will ignore all the command messages unless the multi-drop address matches its own address.

Figure 18 Conceptual diagram for multi-drop connection using RS232 interface

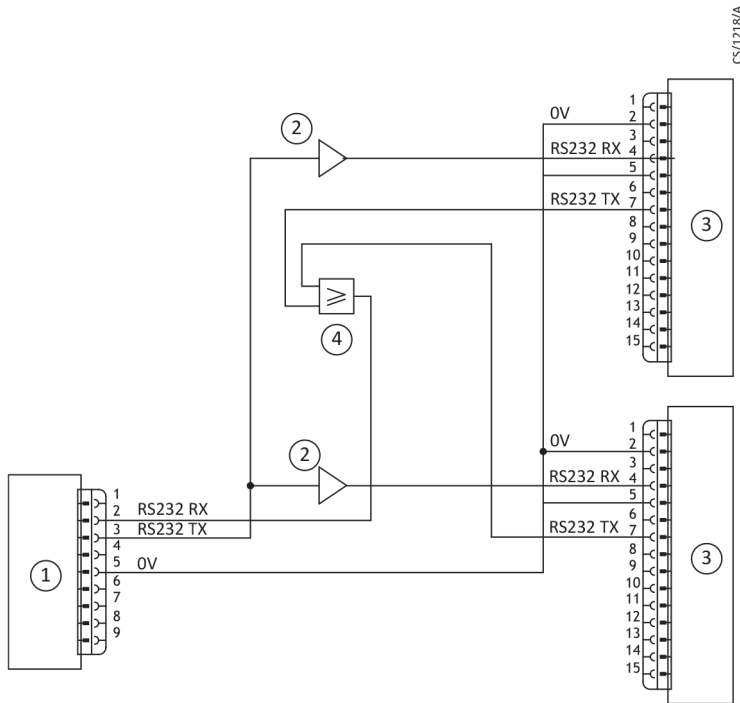

- | | |
|---|------------|
| 1. RS232 interface on control equipment | 2. Buffer |
| 3. nEXT pump | 4. OR gate |

Figure 19 RS485 multi-drop connection

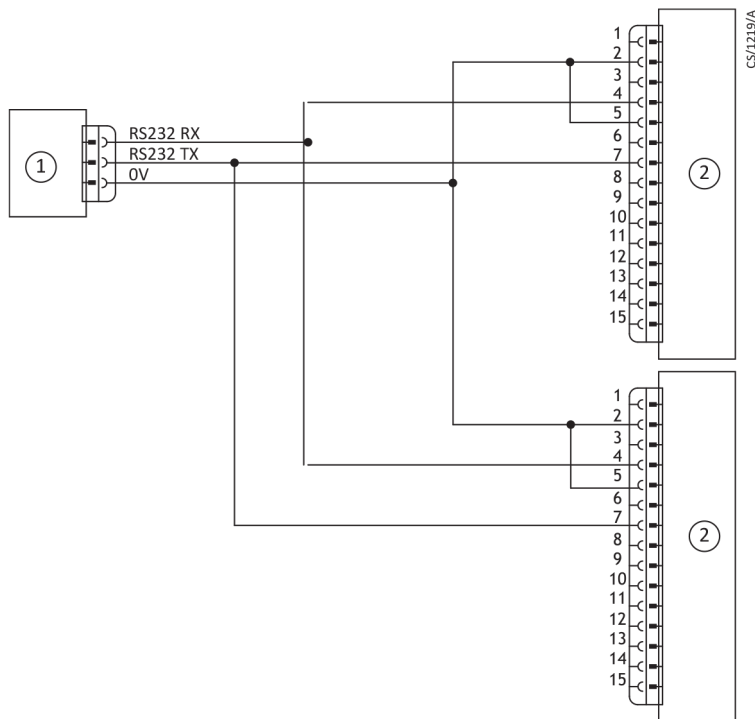

1. RS485 interface on control equipment
2. nEXT pump logic interface

4.7 Connection for mixed parallel and serial operation

You can use the parallel interface control inputs to control the pump. At the same time you can use the serial interface or the USB service port (using the manufacturer's nST PC software) to monitor different pump parameters.

Alternatively, you can use the commands sent over the serial interface to control the pump. At the same time, you can monitor the normal signal and analogue output over the parallel interface.

Refer to [Figure: Logic interface connection - mixed parallel and serial operation on page 55](#) for the schematic diagram of a system that demonstrates how to do this. The connection is a combination of the parallel and serial connection, given in [Connect the parallel control and monitoring on page 43](#) and [Connection for serial control and monitoring on page 45](#). Options given in the sections are available in a mixed parallel and serial operation.

Note:

While serial enable is active to enable the serial link, the parallel standby and fail signals are not available.

The multi-drop connection is shown in [Figure: Logic interface connection - mixed parallel and serial operation on page 55](#). You can use the multi-drop connection with mixed parallel and serial operation.

You cannot use the parallel interfaces and serial interfaces at the same time to control the pump. For example, if you start the pump by sending a start command over the serial interface, you cannot stop the pump by using the start or stop switch on the parallel interface. To stop the pump, send a serial stop command. Only when the serial

stop command has been received by the pump can any commands sent through the parallel interface be acted on.

If you use the start switch on the parallel interface to start the pump, you cannot stop the pump by sending a stop command over the serial interface. To stop the pump, use the parallel stop switch. The serial interface accepts the start or stop commands only when you use the parallel interface switch to stop the pump.

Figure 20 Logic interface connection - mixed parallel and serial operation

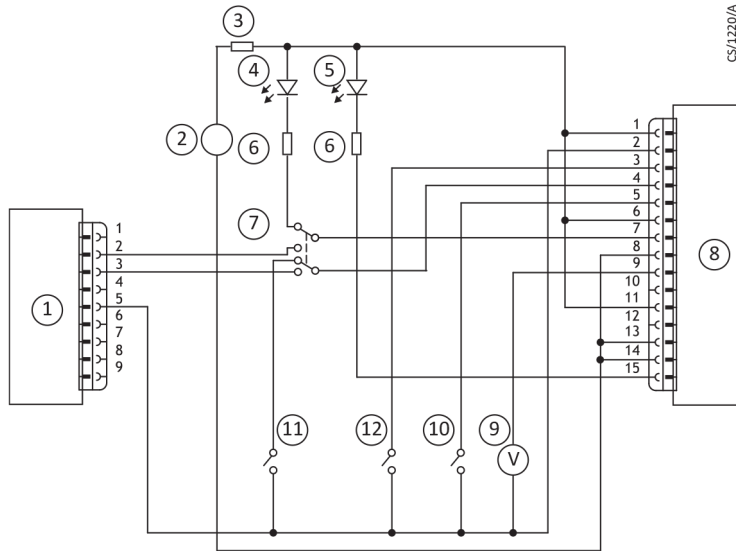

- | | |
|--|---------------------------------------|
| 1. RS232 interface on control equipment | 2. 24 V d.c. electrical supply |
| 3. Fuse | 4. Optional LED indicator - system OK |
| 5. Optional LED indicator - normal speed | 6. Current limit resistor for LED |
| 7. Optional serial link selector | 8. pump |
| 9. Optional voltmeter | 10. Optional serial enable switch |
| 11. Optional standby switch | 12. Start switch |

4.8 Cooling

4.8.1 Cooling requirements

CAUTION: PUMP COOLING



Risk of damage to equipment. Make sure that the pump is sufficiently cooled to prevent damage to the rotor and bearing.

When you use an alternative configuration (other than the manufacturer's standard cooling accessories) to cool the pump, make sure that the cooling is not directed or ducted onto the pump controller.

CAUTION: VENTILATION FOR PUMP



Risk of damage to equipment. If the pump is in an enclosure, make sure that sufficient ventilation is available. The ambient temperature around the pump must not be more than 40 °C.

Note:

During operation, if the temperature of the surface of the pump is higher than 60 °C, you have to increase the cooling. If you do not sufficiently cool the pump and motor controller, it will affect the performance of the pump.

We recommend to cool the pump by forced air-cooling or water-cooling, when possible.

Select the necessary cooling type as per the ambient temperature:

- Natural convection cooling: For the light pumping duties, with an ambient air temperature less than 35 °C, natural convection cooling can be sufficient to cool the pump.
- Forced air-cooling: The ambient air temperature must be 5 °C to 40 °C when you use forced air-cooling. Make sure that there is sufficient supply of cooling air to the pump.
- Water-cooling: Use water-cooling for the higher load applications or when you use a flange heater (CF variants only). Ambient air temperature must be less than 40 °C when you use the water-cooling. The water temperature must be between 10 °C and 40 °C.

Refer to [Pump performance data on page 30](#) for more information on the performance.

4.8.2 Forced air cooling

You can configure the customer controller to operate the air cooler only if the commands can be sent through the serial interface or a manufacturer's TIC Turbo and Instrument Controller or Turbo Controller.

Air-cooling accessories are available for the pump (refer to [Accessories on page 101](#)). Install the air cooler as given in the instruction manual supplied with it. If you use an alternative fan for air-cooling, make sure that the flow rate is more than 100 m³h⁻¹ (60 cfm).

You can supply the power to the air cooler by a customer external power supply, the manufacturer's TIC Turbo and Instrument Controller, the TIC Turbo Controller or the Controller. Connect the connector into the socket at the side of the controller. Refer to [Figure: Auxiliary interface connection on page 71](#).

4.8.3 Water cooling

An accessory is available to water cool the pump. Install the water cooler as given in the instructions supplied with it.

Make sure that the water supply is constant and the quality, temperature and flow rate limits of the water are as per the [Table: Water cooling block supply requirements on page 57](#).



CAUTION: PUMP COOLING

Risk of minor injury or damage to equipment. If the coolant supply fails, cool the pump to ambient temperature before you restart the pump.



CAUTION: CONDENSATION IN PUMP

Risk of damage to equipment. Condensation can occur if you use a water-cooling block in a high humidity environment. Protect the pump and other equipment by considering the design of the installation.

Pipes in the water-cooling circuit can get blocked if the cooling water has too much calcium carbonate or large particles. Corrosion of the water-cooling circuit can occur if the cooling water has too less quantity of calcium carbonate and oxygen. A drinking water of a good quality is applicable. If in doubt, check the quality of the cooling water supply. If necessary, do the treatment and filtration.

1. Connect the cooling water supply to the water cooler at the pump. Use one of the two push-fit connectors on the water cooler for the water supply or return connections.
2. Push the nylon hose (approximately 10 mm outer diameter) into the ends of the hose connectors of the water cooler at the pump. You can also remove the hose connectors from the water cooler to make a connection to the 1/8 inch BSP female threaded installed on the water cooler.

To prevent the breaking of the cooling water circuit when you remove the pump for the maintenance, remove the two M6 screws. Remove the water cooler from the pump.

Table 19 Water cooling block supply requirements

Parameter	Specification
Quality	Mechanically and optically clean with no deposits or turbidity
pH Value	6.0 to 8.0
Maximum calcium carbonate concentration	75 parts per million
Maximum chloride concentration	100 parts per million
Minimum oxygen concentration	4 parts per million
Minimum water-cooling flow rate (at 15 °C)	15 l h ⁻¹
Water temperature range	10 °C to 40 °C
Maximum water pressure	5 bar (gauge), 72.5 psig, 5 x 10 ⁵ Pa gauge
Materials exposed to cooling water	Nickel plated brass

5. Configuration

Before you operate the pump, configure the motor controller settings that are applicable for the application.

If the system is designed to operate with parallel control and monitoring, you cannot change the motor controller settings when the pump is installed on the system. The pump is supplied with the settings at factory default values, as shown in [Table: Summary of commands that can be sent to the pump on page 48](#). If you want to change the motor controller settings, change the settings before you install the pump on the system.

To configure the pump, use one of the methods that follow:

- Use the customer serial comms over the serial interface to configure the pump. Refer to [Configure the pump using serial commands on page 58](#) for the necessary commands to configure the motor controller.
- Use manufacturer's TIC Turbo and Instrument Controller, TIC Turbo Controller or TAG Controller. Refer to [Configure the pump using a TIC on page 65](#) for more information.
- Use manufacturer's nST PC software to configure the pump through the serial interface or through the USB service port.

 **Note:**

Use the button on the motor controller to adjust the standby speed. Refer to [Standby speed setting on page 61](#).

If the nEXT pump is operated with parallel control and monitoring and the controller settings will not be configured again, refer to [Before starting the pump on page 67](#).

5.1 Configure the pump using serial commands

Refer to [Table: Summary of commands that can be sent to the pump on page 48](#) for the summary of the serial commands, parameter ranges and factory defaults for each setting. Refer to the sections that follows for more information about settings.

5.1.1 Message structure

The message structure and command set are same for RS485 and RS232 options. To send a message to the pump, the characters must be sent in a specific order. If the message is in incorrect structure it will be ignored and no reply will be sent.

The correct structure is as follows:

- a valid start character
 - a '!' character for a store operation or
 - a '?' character for a query operation, followed by
- a command: an upper case alphabetical character, followed by
- an object number: has three decimal digits, followed by
- a data field (for some commands only,): has a sequence of characters separated from the object number by a space, followed by
- a terminating carriage return.

The message protocol in multi-drop mode is different. Refer to [Multi-drop operation on page 52](#).

5.1.2 Command and reply table definitions

Explanation of the command and reply characters.

Table 20 Command abbreviations

Abbreviation	Meaning
cr	Carriage return character
chars	Characters
d	Decimal ASCII character*
h	Hexadecimal ASCII character
r	Returned error code. Refer to Command set error codes on page 89 .
sp	Space character
string	Can have some ASCII characters
X	Multi-drop decimal ASCII character [§]

* Fields that have multiple d characters shows typical length. All data fields have a maximum of 5 decimal characters (prefixed by a minus number for the negative numbers).

§ Fields that have multiple X characters shows maximum length and does not show fixed length.

Typical setting command:

Command	!	S	8	5	5	sp	d	d	d	cr
---------	---	---	---	---	---	----	---	---	---	----

Typical setting reply:

Reply	*	S	8	5	5	sp	r	cr
-------	---	---	---	---	---	----	---	----

Typical query command:

Command	?	S	8	5	5	cr
---------	---	---	---	---	---	----

Typical query reply:

Reply	=	S	8	5	5	sp	d	d	d	cr
-------	---	---	---	---	---	----	---	---	---	----

5.1.3 Power limit setting

[Table: Power limit setting on page 60](#) show the power limit setting options for the pump. The pump is supplied with a default power limit. If the default power limit is not applicable for the application, change the default power limit to a value between the maximum and minimum setting.

Table 21 Power limit setting

Maximum value setting	Minimum value setting	Default power setting
120 W	50 W	80 W

Send the command as follows (the 'd' characters shows the value in Watts that will be set. For example, to set the limit to 90 W, type 90).

<i>Command</i>	!	S	8	5	5	sp	d	d	d	cr
----------------	---	---	---	---	---	----	---	---	---	----

The reply is as follows:

<i>Reply</i>	*	S	8	5	5	sp	r	cr
--------------	---	---	---	---	---	----	---	----

The Power Limit Setting is now stored in the memory of the pump.

To check what power limit is set, send a query as follows:

<i>Command</i>	?	S	8	5	5	cr
----------------	---	---	---	---	---	----

The reply as follows:

<i>Reply</i>	=	S	8	5	5	sp	d	d	d	cr
--------------	---	---	---	---	---	----	---	---	---	----

5.1.4 Power supply to the fan from the motor controller

The motor controller on auxiliary output 2 can supply the power to the fan.

Send the command that follows:

<i>Command</i>	!	S	8	6	4	sp	8	cr
----------------	---	---	---	---	---	----	---	----

The reply is as follows:

<i>Reply</i>	*	S	8	6	4	sp	r	cr
--------------	---	---	---	---	---	----	---	----

The permanently enabled fan setting is now stored in the memory of the pump.

When the pump is shipped, it is set up to operate a vent valve. Send a query that follows to find the setting:

<i>Command</i>	?	S	8	6	4	cr
----------------	---	---	---	---	---	----

The reply is as follows:

<i>Reply</i>	*	S	8	6	4	sp	d	cr
--------------	---	---	---	---	---	----	---	----

If the character 'd' is 8, the fan is enabled. If the character 'd' is other than 8, configure the motor controller to operate the fan.

5.1.5 Controlled venting options

A number of vent options are available if you use the motor controller to automatically control a vent valve.

Refer to [Table: Vent valve options on page 69](#) for available venting options. Refer to [Table: Valve types on page 70](#) for available valve types.

To set a vent option on auxiliary output 1, send the command that follows (character 'd' refers to the option number shown in [Table: Vent valve options on page 69](#)):

Command	!	S	8	5	3	sp	d	cr
---------	---	---	---	---	---	----	---	----

The reply is as follows:

Reply	*	S	8	5	3	sp	r	cr
-------	---	---	---	---	---	----	---	----

The venting option is now stored in the memory of the pump.

To check what venting option is set, send a query that follows:

Command	?	S	8	5	3	cr
---------	---	---	---	---	---	----

The reply is as follows:

Reply	=	S	8	5	3	sp	d	cr
-------	---	---	---	---	---	----	---	----

To set the valve type on auxiliary output 1, send the command that follows (character 'd' refers to the option number shown in [Table: Valve types on page 70](#)):

Reply	!	S	8	7	7	sp	d	cr
-------	---	---	---	---	---	----	---	----

The reply is as follows:

Reply	*	S	8	7	7	sp	d	cr
-------	---	---	---	---	---	----	---	----

The valve type is now stored in the memory of the pump, but a power cycle is necessary before the auxiliary 1 output circuit adjusts to the stored request.

To check what venting option is set, send a query as follows:

Reply	?	S	8	7	7	cr
-------	---	---	---	---	---	----

The reply is as follows:

Reply	=	S	8	7	7	sp	d	cr
-------	---	---	---	---	---	----	---	----

5.1.6 Standby speed setting

You can operate the pump at a standby speed rather than full rotational speed. The standby speed is a user-configurable option and can be set to the value between 55% and 100% full rotational speed. When the pump is shipped, it is configured with a standby speed of 70% full rotational speed.

To change the standby speed setting, use one of the methods that follows:

- Use the STDBY+ and STDBY- push buttons (given on the motor controller). Each push of the button adjusts the speed by 15 Hz (1%). Refer to [Figure: Motor controller status information on page 46](#).
- Use a serial command

To change the standby speed setting using a serial command, send the command that follows (characters 'd' shows the value as a percentage of full rotational speed):

Command	!	S	8	5	7	sp	d	d	d	cr
---------	---	---	---	---	---	----	---	---	---	----

The reply is as follows:

Reply	*	S	8	5	7	sp	r	cr
-------	---	---	---	---	---	----	---	----

The standby speed is now stored in the memory of the pump.

To check what Standby Speed is set, send a query as follow:

<i>Command</i>	?	S	8	5	7	cr
----------------	---	---	---	---	---	----

The reply is as follows:

<i>Reply</i>	=	S	8	5	7	sp	d	d	d	cr
--------------	---	---	---	---	---	----	---	---	---	----

5.1.7 Normal speed setting

The normal speed is a user-configurable setting and can be set to the value between 50% and 100% full rotational speed. When the pump is shipped, it is configured with a normal speed of 80% full rotational speed.

To change the normal speed setting, send the command that follows (characters 'd' shows the value as a percentage of full rotational speed):

<i>Command</i>	!	S	8	5	6	sp	d	d	d	cr
----------------	---	---	---	---	---	----	---	---	---	----

The reply is as follows:

<i>Reply</i>	*	S	8	5	6	sp	r	cr
--------------	---	---	---	---	---	----	---	----

The normal speed is now stored in the memory of the pump.

To check what normal speed is set, send a query as follows:

<i>Command</i>	?	S	8	5	6	cr
----------------	---	---	---	---	---	----

The reply is as follows:

<i>Reply</i>	=	S	8	5	6	sp	d	d	d	cr
--------------	---	---	---	---	---	----	---	---	---	----

5.1.8 Timer setting and options

The timeout period is a user-configurable option and can be set to the value from 1 to 30 minutes.

When the pump is shipped, it is configured with a default timeout period of 8 minutes. Refer to [Timer on page 12](#) for a full description of timer functionality.

To change the timer setting, send the command that follows (where the characters 'd' represent the timeout period in minutes):

<i>Command</i>	!	S	8	5	4	sp	d	d	cr
----------------	---	---	---	---	---	----	---	---	----

The reply will be as follows:

<i>Reply</i>	*	S	8	5	4	sp	r	cr
--------------	---	---	---	---	---	----	---	----

The Timer setting is now stored in the memory of the pump.

To check what time-out period is set, send a query as follows:

<i>Command</i>	?	S	8	5	4	cr
----------------	---	---	---	---	---	----

The reply will be as follows:

<i>Reply</i>	=	S	8	5	4	sp	d	d	cr
--------------	---	---	---	---	---	----	---	---	----

The timer is permanently enabled during ramp-up. However, it is optional to have the timer enabled at other times. When the pump is shipped, the Timer is enabled by default.

To disable the timer, send the serial command that follows:

<i>Command</i>	!	S	8	7	0	sp	0	cr
----------------	---	---	---	---	---	----	---	----

The reply will be as follows:

<i>Reply</i>	*	S	8	7	0	sp	r	cr
--------------	---	---	---	---	---	----	---	----

The state of the timer option is stored in the memory of the pump.

To enable the timer again, send the serial command that follows:

<i>Command</i>	!	S	8	7	0	sp	1	cr
----------------	---	---	---	---	---	----	---	----

The reply will be as follows:

<i>Reply</i>	*	S	8	7	0	sp	r	cr
--------------	---	---	---	---	---	----	---	----

To check if the timer is enabled or disabled, send the query that follows:

<i>Command</i>	?	S	8	7	0	cr
----------------	---	---	---	---	---	----

The reply will be as follows (where d=0 means disabled and d=1 means enabled):

<i>Reply</i>	=	S	8	7	0	sp	d	cr
--------------	---	---	---	---	---	----	---	----

5.1.9 Analogue signal options

The analogue output can be used to monitor one of the five different parameters.

Table 22 Analogue signal options

Option number	Description of analogue output number
0	Measured pump rotational speed. This is the factory default setting.
1	Measured link power
2	Measured motor temperature
3	Measured motor controller temperature
4	Measured rotor temperature

To configure the analogue output, send the command that follows (where the character 'd' shows the option number):

<i>Command</i>	!	S	8	7	1	sp	d	cr
----------------	---	---	---	---	---	----	---	----

The reply will be as follows:

<i>Reply</i>	*	S	8	7	1	sp	d	cr
--------------	---	---	---	---	---	----	---	----

The analogue output signal setting is now stored in the memory of the pump.

To check which analogue output signal setting is enabled, send a query as follows:

<i>Command</i>	?	S	8	7	1	cr
----------------	---	---	---	---	---	----

The reply will be as follows:

<i>Reply</i>	=	S	8	7	1	sp	d	cr
--------------	---	---	---	---	---	----	---	----

5.1.10 Electronic braking options

Refer to [Electronic braking on page 14](#) for a full description of the electronic braking feature. To enable Electronic Braking, send the serial command that follows:

<i>Command</i>	!	S	8	7	2	sp	1	cr
----------------	---	---	---	---	---	----	---	----

The reply will be as follows:

<i>Reply</i>	*	S	8	7	2	sp	r	cr
--------------	---	---	---	---	---	----	---	----

The state of the Electronic Braking option is stored in the memory of the pump.

To disable the Electronic Braking again, send the serial command that follows:

<i>Command</i>	!	S	8	7	2	sp	0	cr
----------------	---	---	---	---	---	----	---	----

The reply will be as follows:

<i>Reply</i>	*	S	8	7	2	sp	r	cr
--------------	---	---	---	---	---	----	---	----

To check if electronic braking is enabled or disabled, send the query that follows:

<i>Command</i>	?	S	8	7	2	cr
----------------	---	---	---	---	---	----

The reply will be as follows (where d=0 means disabled and d=1 means enabled):

<i>Reply</i>	=	S	8	7	2	sp	d	cr
--------------	---	---	---	---	---	----	---	----

5.1.11 Factory settings

The pump can be configured again to its original factory settings with one serial command.

To reset the motor controller to factory settings, send the command that follows:

<i>Command</i>	!	S	8	6	7	sp	1	cr
----------------	---	---	---	---	---	----	---	----

The reply will be as follows:

<i>Reply</i>	*	S	8	6	7	sp	r	cr
--------------	---	---	---	---	---	----	---	----

The factory settings are restored in the memory of the pump. If the valve type setting was previously configured to a non-default setting, a Power cycle can be necessary.

5.1.12 Assigning a multi-drop address

Each individual pump must be programmed with its own multi-drop address through a point-to-point connection before introduction into a multi-drop network.

When the pump is shipped, multi-drop mode is disabled by default.

To assign a multi-drop address, send the command that follows (where the 'd' characters represent the address):

Command	!	S	8	5	0	sp	d	d	cr
---------	---	---	---	---	---	----	---	---	----

Note:

The address can be a decimal number from 1 to 98. The address number 0 is used to disable multi-drop mode. The address number 99 is reserved as a wild card and is used in the query set up detailed later.

The reply will be as follows:

Reply	*	S	8	5	0	sp	r	cr
-------	---	---	---	---	---	----	---	----

The multi-drop address is stored in the pump.

To check if the pump has a multi-drop address, send the command that follows:

Command	?	S	8	5	0	cr
---------	---	---	---	---	---	----

If the reply is as follows, the pump has multi-drop mode disabled:

Reply	=	S	8	5	0	sp	0	cr
-------	---	---	---	---	---	----	---	----

If the pump has a multi-drop address, there will be no reply. Communicate with the pump in multi-drop message protocol. Refer to [Multi-drop operation on page 52](#) for more information about multi-drop mode and multi-drop message protocol.

To check the multi-drop address of the pump, send the query as follows (using wild card address 99 which means 'any' node):

Command	#	9	9	:	9	9	?	S	8	5	0	cr
---------	---	---	---	---	---	---	---	---	---	---	---	----

The reply will be as follows, where dd shows the multi-drop address of the pump:

Reply	#	9	9	:	9	9	=	S	8	5	0	sp	d	d	cr
-------	---	---	---	---	---	---	---	---	---	---	---	----	---	---	----

Multi-drop mode can be disabled by assigning the pump an address 0. To do this, send the command that follows (where dd shows the multi-drop address of the pump. XX shows the address of the node that is sending the command):

Command	#	d	d	:	x	x	1	S	8	5	0	sp	0	cr
---------	---	---	---	---	---	---	---	---	---	---	---	----	---	----

The reply will be as follows:

Reply	#	x	x	:	d	d	*	S	8	5	0	sp	0	cr
-------	---	---	---	---	---	---	---	---	---	---	---	----	---	----

When the multi-drop mode is disabled, the pump will not respond to multi-drop commands.

5.2 Configure the pump using a TIC

The pump can be configured using the manufacturer's TIC Turbo and Instrument Controller or TIC Turbo Controller. Refer to [Connect the logic interface to the TIC or TAG on page 42](#).

The parameters of the pump that can be set using the TIC are:

- Power limit setting
- Vent options and vent type, including operating a fan from the motor controller
- Standby speed setting

- Normal speed setting
- Timer settings - to enable and disable the timer, setting the time-out period
- Electronic braking options
- Factory default settings

Refer to the TIC Turbo and Instrument Controller or TIC Turbo Controller Instruction Manuals for information on how to do the settings.

 **Note:**

You cannot configure the Analogue Output Options using the TIC. You cannot assign a multi-drop address to the pump with the TIC.

6. Operation

6.1 Before starting the pump

Before you start the pump:

- close the vent valve
- make sure that the pre-start sequence is completed.

6.1.1 Close the vent valve

You can manually close the vent valve by using the customer control system or TAV5 solenoid valve.

1. If you use a manual vent valve, turn it clockwise to close the vent valve.
2. If you use the customer control system to drive a vent valve, make sure that the vent valve is closed.
3. If you operate a TAV solenoid valve from the motor controller, the TAV valve will be closed automatically when the pump is started.
4. If you use the TIC to operate the vent valve, refer to [Operation with a TIC or TAG on page 77](#).

 **Note:**

The backing pump and nEXT85 pump can be started at the same time. The nEXT85 pump will not get damaged and can operate as an effective baffle. If the vacuum system is large (100 litres or larger), it will be more efficient to allow the backing pump to decrease the system pressure to 10 mbar before you start the nEXT85 pump. Close the vent valve before you start the backing pump.

When you use the motor controller to control the TAV solenoid valve and operate with parallel control and monitoring, you cannot close the valve before starting the nEXT85 pump (the facility to send the applicable serial command is not available). If the facility to send serial commands is available, a delayed start can be done. Refer to [Delayed start on page 73](#).

6.1.2 Pre-start sequence

Complete the pre-start sequence to check that the pump is ready for operation.

 **Note:**

If the motor controller has been configured to operate a fan, the fan will start automatically when the power is supplied to the nEXT pump.

1. Turn on the applicable cooling device (fan or cooling water supply).
2. Start the backing pump.
3. Set the power supply to the pump to on.
4. Check that the three LEDs (normal, status and alarm LEDs) on the motor controller illuminate for approximately 0.5 seconds and then extinguish.

Refer to [Fault finding on page 86](#) if:

- LEDs do not illuminate
- Red or yellow LEDs flash in a repeated sequence
- Red LED is illuminated.

6.2 Vent options, vent valve connection and control

Note:

If manually venting the pump when it is at full rotational speed and the rate of increase in pressure is too high, the pump life can decrease. When using the manual vent valve, we recommend you to limit the vent or open the vent valve only after the pump speed decreases to 50% of the full rotational speed. Do not vent from the backing line to prevent contamination. If venting into the vacuum system and using an oil sealed rotary backing pump, select a point upstream of the pump to prevent oil back-streaming from the backing line. The vent rate must be as per the limits given in [Vent gas specification and vent control data on page 20](#). Refer to [Table: Vent restrictor orifice diameter if venting the vacuum system chamber on page 71](#) for the vent restrictor orifice to be installed on the vent valve.

To keep the cleanliness of the vacuum system, we recommend you to vent the pump (or vacuum system) when setting the pump to off.

6.2.1 Manual vent valve

We recommend you to open the manual vent valve only after the pump speed decreases to 50% of the full rotational speed.

A manual vent valve is supplied with the pump. Precise controlling of the rate of increase in pressure is not possible with the manual vent valve. Do not open the manual vent valve too quickly.

6.2.2 TAV5 solenoid vent valve

The TAV5 solenoid valves is available as an accessory. The TAV5 solenoid valves comes as pre-wired with an auxiliary connector installed or as a bare-wire option.

'Normally Closed' and 'Normally Open' valves are available. Refer to [Accessories on page 101](#).

Venting can be done by one of the methods that follow:

- Use the TAV5 solenoid vent valve in the manual vent valve position.
- Use the TAV5 solenoid vent valve connected to a convenient flange on the vacuum system.
- Use an alternative vent valve, with correct restriction, connected to the vacuum system.

When using the TAV5 vent valve, the pump can be hard vented only when it is at full speed if the vacuum system has a volume of 5 litres or more.

If the volume of the vacuum system is less than 5 litres, install a vent restrictor and vent the pump when it is at full speed or use the controlled venting option. Refer to [Table: Vent restrictor orifice diameter if venting the vacuum system chamber on page 71](#) for

applicable orifice size to be installed to the vent valve. Make sure that the rate of increase in pressure is in the limits shown in [Vent gas specification and vent control data on page 20](#).

 **Note:**

If a vent restrictor is used, the time necessary to vent the vacuum system can be long. To decrease the time:

- use vent valve without a vent restrictor.

- wait until the pump speed decreases to 50% of the full rotational speed before you open the vent valve.

6.2.3 Vent valve control

The TAV5 solenoid valve can be controlled by the motor controller or by the manufacturer's TIC Turbo Instrument Controller.

The controller can control the rate of venting, using the vent valve options given in [Table: Vent valve options on page 69](#). With this feature, the pump can be vented from full rotational speed in a controlled manner that will not damage the pump bearings. It is safe to hard vent (open the vent valve fully) when:

- the rotational speed of the pump decreases below 50% of maximum speed and
- the backing pump is on and the backing valve is open.

To use the controller function, the turbo pump controller has a 4-pin auxiliary connector socket on the side of the pump. The vent valve with the auxiliary connector installed is plugged into the 4-pin auxiliary connector socket. Refer to [Figure: Auxiliary interface connection on page 71](#).

The controller can control number of different venting options. Refer to [Table: Vent valve options on page 69](#).

The controller can accommodate normally open and normally closed vent valve types. Refer to [Table: Valve types on page 70](#). A power cycle is necessary after making a change to the valve type, before the auxiliary output circuitry adjusts to accommodate the requested change.

Table 23 Vent valve options

Option number	Description of vent function
0	Vent valve opens fully below 50% full rotational speed for a stop command or fail condition.*
1	Controlled venting from 100% to 50% full rotational speed and then vent valve opens fully below 50% for a stop command or fail condition.
2	If a stop command is received, vent valve fully opens. In a fail condition, vent valve opens fully below 50% full rotational speed.
3	If a stop command is received, vent valve fully opens. In a fail condition, controlled venting from 100% to 50% full rotational speed and then vent valve opens fully below 50%.

Option number	Description of vent function
4	In a fail condition, vent valve fully opens. If a stop command is received, vent valve opens fully below 50% full rotational speed.
5	In a fail condition, vent valve fully opens. If a stop command is received, controlled venting from 100% to 50% full rotational speed and then vent valve opens fully below 50%.
6	Vent valve fully opens for a stop command or a fail condition.
7	Same as option 6
8	Auxiliary output is permanently energised (Fan). [§]
9	Do not use
10	Auxiliary output is permanently de-energised (Fan).
11	Do not use
12	Do not use
13	Do not use
14	Vent valve opens fully below 50% full rotational speed for a stop command.
15	Controlled venting from 100% to 50% full rotational speed and then vent valve opens fully below 50% for a stop command.

* This is the factory default setting for Vent Option 1.

§ This is the factory default setting for Vent Option 2 to enable cooling fan behaviour.

Table 24 Valve types

Option number	Description of valve type
0	Normally open vent valve*
1	Normally closed vent valve

* This is the factory default setting for Valve 1 type and Valve 2 type.

When the pump is shipped, the controller is configured with the factory default Vent option 1 set to 0 and the Valve 1 type set to 0, as given in [Table: Vent valve options on page 69](#) and [Table: Valve types on page 70](#). The controller can be configured to one of the other venting options provided commands can be sent through the serial interface or a manufacturer's TIC Turbo and Instrument Controller or TIC Turbo Controller or the manufacturer's nST PC software can be used through the USB serial port.

If the valve type is set to normally open, the controller only energises or shuts the TAV solenoid valve when it receives a start command. Before that, the valve will be in the 'open' vent state. If the vacuum system is large, allow the backing pump to decrease the pressure in the system to a permitted level before you start the pump. Send a command through the serial interface to close the vent valve before sending a start command – this is known as a delayed start.

If the valve type is set to normally closed, and vent options 14 or 15 are used, the controller will ensure that the TAV solenoid valve will only ever 'open' upon receipt of a stop command. There is no need to send the delayed start command.

If the pump is controlled with a manufacturer's TIC Turbo and Instrument Controller or TIC Turbo Controller, the TAV solenoid valve can be operated from the TIC. Refer to the TIC Instruction Manuals for more information.

Figure 21 Auxiliary interface connection

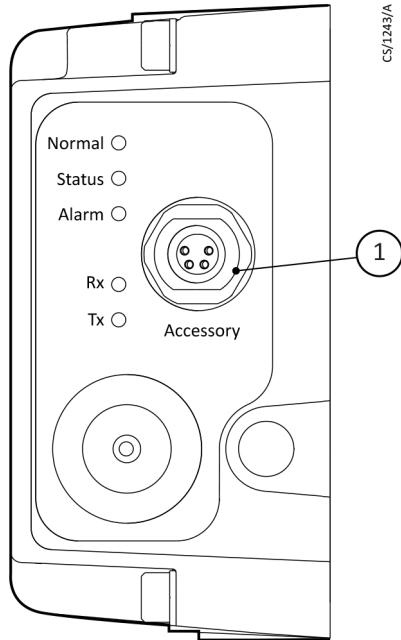

1. Accessory connector

6.2.4 Alternative valve connected to the vacuum system

When you use another vent valve, install a vent restrictor to the vacuum system to limit the rate of increase in pressure.

Refer to [Table: Vent restrictor orifice diameter if venting the vacuum system chamber on page 71](#) for information about vent restrictor sizes. If a vent restrictor is not installed, open the vent valve only after the speed of the pump decreases to 50% of full rotational speed.

Vacuum system volume (litres)	Orifice diameter (mm)
< 20	< 1.0
< 10	< 0.7
< 5	< 0.5
< 2	< 0.35

6.3 Operation with parallel control and monitoring

6.3.1 Start the pump



WARNING: EXPOSED ROTOR

Risk of injury. Do not operate the pump with its rotor exposed. Connect the pump to the vacuum system before you operate the pump. If the pump is operated with its rotor exposed, the pump rotor can cause injury as it rotates at high speeds and the rotating blades are not visible.



WARNING: PUMP RESTART AFTER POWER CUT

Risk of injury. When the power is restored after a power cut, the pump will restart automatically. Keep the pump connected to the vacuum system to prevent risk of injury.



CAUTION: PUMP MOVEMENT

Risk of damage to equipment. Do not move the pump when it is in operation. The gyroscopic forces generated by this movement can cause more use of the back up bearing and can result in catastrophic failure of the pump.

In parallel control, the pump will accelerate to full operating speed when started.

To start the pump, link the start/stop control input to the 0 V control reference on the logic interface connector.

The green indicator on the motor controller illuminates when the pump reaches normal speed. This is 80% of the full rotational speed by default, but a different value can be selected to suit the application.

6.3.2 Run the pump at standby speed

If the pump operates at less than or more than the standby speed it will accelerate or decelerate until standby speed is reached.

1. To operate the pump at standby speed, link the standby control input to the 0 V control reference on the logic interface connector.
2. To return the pump to full speed, disconnect the standby control input from the 0 V control reference on the logic interface connector.

6.3.3 Stop the pump



WARNING: MECHANICAL ENERGY IN ROTOR

Risk of injury. After the pump is set to off, the rotor will continue to rotate at high speeds through an emergency or as a requirement. The rotor has mechanical energy until it slows down and stops.



WARNING: EXPOSURE TO BACK E.M.F

Risk of injury or damage to equipment. Do not remove the controller from the pump until the pump stops completely. The exposed electrical pins may pose a potential hazard. The user could also be exposed to a back e.m.f. from the pump and potentially damage the controller.

With parallel control, the pump rotor will decelerate when stopped.

To stop the pump, disconnect the start/stop control input from the 0 V control reference on the logic interface connector.

6.3.4 Parallel monitoring

The parameters that follows can be monitored:

- Analogue output
- Normal signal
- Fail signal

Refer to [Connect the parallel control and monitoring on page 43](#) for instructions on how to monitor the signals.

6.4 Operation with serial control and monitoring

6.4.1 Delayed start

If using a TAV solenoid valve controlled by the motor controller, it can be closed before starting the pump. This allows the backing pump to decrease the pressure in the vacuum system.

To close the vent valve, send the command that follows:

Command	!	c	8	7	5	sp	1	cr
---------	---	---	---	---	---	----	---	----

The reply is as follows:

Reply	*	c	8	7	5	sp	r	cr
-------	---	---	---	---	---	----	---	----

Note:

This command overrides the current vent option and closes the vent valve. There is no command to open the vent valve but, when a stop command is sent to the pump, the override will be cleared.

6.4.2 Start the pump



WARNING: EXPOSED ROTOR

Risk of injury. Do not operate the pump with its rotor exposed. Connect the pump to the vacuum system before you operate the pump. If the pump is operated with its rotor exposed, the pump rotor can cause injury as it rotates at high speeds and the rotating blades can not be visible.



WARNING: AUTOMATIC RESTART

Risk of injury. When the power is restored after a power cut, the pump will restart automatically. Keep the pump connected to the vacuum system to prevent risk of injury.



CAUTION: PUMP MOVEMENT

Risk of damage to equipment. Do not move the pump when it is in operation. The gyroscopic forces generated by this movement can cause more use of the back up bearing and can result in catastrophic failure of the pump.

In serial control, the pump will accelerate to full operating speed when started.

To start the pump, send the command (over the serial communications link) that follow:

<i>Command</i>	!	c	8	5	2	sp	1	cr
----------------	---	---	---	---	---	----	---	----

The reply is as follows:

<i>Reply</i>	*	c	8	5	2	sp	1	cr
--------------	---	---	---	---	---	----	---	----

The green indicator LED illuminates when the pump reaches normal speed. This is 80% of the full rotational speed by default, but a different value can be selected to suit the application.

6.4.3 Run the pump at standby speed

If the pump operates at less than or more than the standby speed it will accelerate or decelerate until standby speed is reached.

To operate the pump at standby speed, send the command (over the serial communications link) that follows:

<i>Command</i>	!	c	8	6	9	sp	1	cr
----------------	---	---	---	---	---	----	---	----

The reply is as follows:

<i>Reply</i>	*	c	8	6	9	sp	r	cr
--------------	---	---	---	---	---	----	---	----

To return the pump to full speed, send the command that follows:

<i>Command</i>	!	c	8	6	9	sp	0	cr
----------------	---	---	---	---	---	----	---	----

The reply is as follows:

<i>Reply</i>	*	c	8	6	2	sp	r	cr
--------------	---	---	---	---	---	----	---	----

6.4.4 Stop the pump

When the stop command is received, the pump rotor will decelerate and stop.

To stop the pump, send the command (over the serial communications link) that follows:

<i>Command</i>	!	c	8	5	2	sp	0	cr
----------------	---	---	---	---	---	----	---	----

The reply is as follows:

<i>Reply</i>	*	<i>c</i>	8	5	2	<i>sp</i>	<i>r</i>	<i>cr</i>
--------------	---	----------	---	---	---	-----------	----------	-----------

6.4.5 Monitor temperature readings

It is possible to monitor the following parameters:

- temperatures of the pump motor
- rotor
- internal electronics of the pump.

Send the query that follows:

<i>Command</i>	?	<i>v</i>	8	6	5	<i>sp</i>	<i>cr</i>
----------------	---	----------	---	---	---	-----------	-----------

The reply is as follows:

<i>Reply</i>	=	<i>v</i>	8	6	5	<i>sp</i>	<i>d</i>	<i>d</i>	<i>d</i>	;	<i>d</i>	<i>d</i>	<i>d</i>	;	<i>d</i>	<i>d</i>	<i>d</i>	<i>cr</i>
--------------	---	----------	---	---	---	-----------	----------	----------	----------	---	----------	----------	----------	---	----------	----------	----------	-----------

Here:

- first number is the motor temperature
- second number is the motor controller temperature
- third number is the rotor temperature, all measured in °C.

6.4.6 Monitor link parameter readings

The parameters that follows can be monitored:

- internal voltage
- current and motor power of the pump.

Send the query that follows:

<i>Command</i>	?	<i>v</i>	8	6	0	<i>cr</i>
----------------	---	----------	---	---	---	-----------

The reply is as follows:

<i>Reply</i>	=	<i>v</i>	8	6	0	<i>sp</i>	<i>d</i>	<i>d</i>	<i>d</i>	;	<i>d</i>	<i>d</i>	<i>d</i>	;	<i>d</i>	<i>d</i>	<i>d</i>	<i>d</i>	<i>d</i>	<i>cr</i>
--------------	---	----------	---	---	---	-----------	----------	----------	----------	---	----------	----------	----------	---	----------	----------	----------	----------	----------	-----------

Here:

- first number shows the link voltage (measured in 0.1 Volts - i.e. divide the number by 10 to get the answer in Volts)
- second number shows the link current (measured in 0.1 Amps)
- third number shows the link power (measured in 0.1 Watts).

6.4.7 Monitor measured motor speed

The measured rotational speed of the motor in the pump can be monitored.

Send the query that follows:

<i>Command</i>	?	<i>v</i>	8	5	2	<i>cr</i>
----------------	---	----------	---	---	---	-----------

The reply is follows (where first returned number shows the motor rotational speed in revolutions per second (Hz)):

Reply	=	v	8	5	2	sp	d	d	d	d	;	h	h	h	h	h	h	h	h	cr
-------	---	---	---	---	---	----	---	---	---	---	---	---	---	---	---	---	---	---	---	----

Note:

The second return number is a 32-bit system status word (set of 8 hexadecimal characters) which is useful for fault finding. Refer to [Fault finding on page 86](#).

6.5 Mixed parallel and serial operation

In mixed parallel and serial operation the pump can receive commands from serial and parallel interfaces. Refer to [Figure: Logic interface connection - mixed parallel and serial operation on page 55](#) to understand how the commands control the pump. The pump will power up with 'None in Control'. From this state a parallel start signal or a serial start command can be received, which can move the pump to parallel control mode or serial control mode. Serial start commands can be received only if the serial enable line is active.

The state of the serial enable line can be switched between active and inactive while in mixed parallel and serial operation. The primary function of the serial enable line is to enable the serial link. It has no direct effect on the control mode. The pump will receive and respond to serial commands whenever the serial enable line is active. The pump will not receive or respond to serial commands when the serial enable line is inactive.

Availability of the parallel standby and fail signals depends on the state of the serial enable line and the position of the RS485/RS232 switch as given in [Table: Serial enable matrix on page 76](#).

Table 25 Serial enable matrix

Switch	Serial enable active	Serial enable inactive
RS232	Standby and fail lines are used for RS232 data.	Standby and fail lines are used for parallel Standby control and fail indication.
	Parallel standby control and fail indication are disabled.	Serial communications are disabled.
RS485	Standby and fail lines are used for RS485 data.	Standby and fail lines are in (RS485) high impedance state.*
	Parallel standby control and fail indication are disabled.	Serial communications are disabled.

* Pump target speed will switch between run speed and standby speed in response to data driven onto the RS485 bus by other devices connected to the bus. It is not recommended to activate the parallel start line with the RS485/232 switch in RS485 position and serial enable Inactive. Deactivation of the serial enable line is not recommended with the pump running following a start from the parallel start line when the RS485/232 switch is in the RS485 position.

In parallel control mode, the pump does not accept serial stop commands but will accept all other serial commands. When serial enable is active, the pump will operate at standby speed if the serial standby command is given.

The pump will operate at standby speed when:

- Serial enable is inactive

- RS485/RS232 switch is in RS232 position and
- parallel standby line is active.

In serial control mode, the state of the parallel Start line will be ignored but the serial enable line gives an interlock function as shown in [Figure: Serial and parallel control flowchart on page 77](#). This interlock function only operates with serial start commands and in serial control mode only. In serial control mode, the pump cannot be commanded to standby speed by the standby line, instead a serial standby command must be used.

The parallel normal and analogue output signals give valid pump status information at all times under mixed parallel and serial operation. The analogue output voltages are given in [Table: Logic interface technical data on page 25](#).

Figure 22 Serial and parallel control flowchart

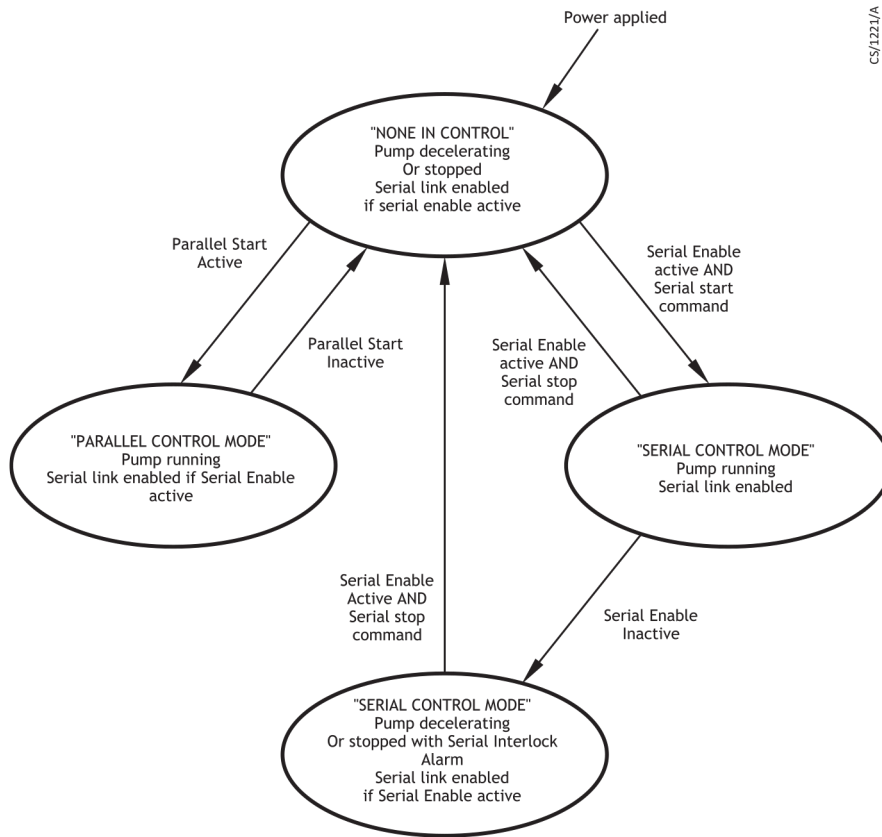

6.6 Operation with a TIC or TAG

The pump can be connected to manufacturer's TIC Turbo Instrument Controller, TIC Turbo Controller or TAG Controller. The TIC gives the power necessary to operate the pump, but the TAG requires a separate PSU to be connected.

Instructions on the setup and operation with the TIC Turbo Instrument Controller, TIC Turbo Controller or TAG Controller can be found on CD ROM part number P450-00-000, which is supplied with the TIC or TAG.

6.7 Decelerating and venting

Decelerate the pump before venting.

The system can be vented in accordance with the advice given in [Vent options, vent valve connection and control on page 68](#).



CAUTION: RATE OF INCREASE IN PRESSURE

Risk of damage to equipment. Do not open a manual vent valve until the pump rotational speed decreases below 50%, otherwise the rate of increase in pressure can be too high, which can damage the pump. In an emergency, open the vent valve quickly to decelerate the pump rotor in the shortest possible time.

If using the motor controller to control a TAV solenoid valve, there is a 2-second delay between:

- receiving a stop command or a detecting a fault condition and
- opening of the vent valve.

The delay allows time for gauges, valves and other equipment to set to off before venting occurs.

The green indicator LED on the motor controller will extinguish as rotational speed drops below normal speed. At very low speeds, the yellow indicator LED flashes. The yellow indicator LED extinguishes when the pump has stopped.

The deceleration time can be improved by using the electronic braking feature. Refer to [Electronic braking options on page 64](#).

6.8 Operation at extreme conditions

6.8.1 Operation with high inlet pressure

If the pump inlet pressure increases, the power supplied to the pump motor will increase to counteract the gas frictional load.

The pump rotational speed will stay constant until the peak power level is reached. After the peak power level, the speed of the pump will start to decrease.

If the pump speed decreases below 50% of full rotational speed, the timer will start (if it is enabled). If the speed does not recover to more than 50% speed before the timeout period expires, the pump will stop and display a fail signal. If the timer is disabled, the pump will stop immediately and display a fail signal if the speed decreases below 50% of the full rotational speed. Refer to [Electrical data on page 22](#) for the maximum power delivered to the pump. Refer to [Table: Pump performance data on page 30](#) for maximum permitted inlet pressure.

6.8.2 Operation at high temperatures

Temperature sensors in the pump mechanism and electronics are monitored by an internal system. If the system detects that internal temperatures are too high, the power supplied to the pump motor is decreased. The pump cannot keep full rotational speed if it is too hot.

If the pump speed decreases below 50% of the full rotational speed, the timer will start (if it is enabled). If the speed does not recover to more than 50% speed before the timeout period expires, the pump will stop and display a fail signal. If the timer is disabled, the pump will stop immediately and display a fail signal if the speed decreases

below 50% of the full rotational speed. Refer to [Table: Operating and storage conditions on page 20](#) for pump operating ranges. Refer to [Cooling on page 55](#) for advice on pump cooling.

6.8.3 Protection against over-speed

Control software in the motor controller controls the pump rotational speed and prevents the operation of the pump more than its normal full rotational speed.

If the control software fails, the motor controller has a built-in safety circuit that checks if the pump is operating at over-speed. If an over-speed condition is detected, the motor controller automatically stops the power to the pump motor and slows the pump to a stop. The motor controller signals a fail condition if over-speed is detected.

If the pump is operating at over-speed, set the pump to off and contact us or the supplier.

6.8.4 Electrical supply failure



WARNING: POWER SUPPLY FAILURE

Risk of injury. If the power supply fails when the pump is in operation, the rotor can spin for approximately 30 minutes. The control circuit can possibly not give indication that the rotor is spinning.



WARNING: AUTOMATIC RESTART

Risk of injury. If the parallel start control signal on the logic interface connector is set to start, the pump can automatically restart when the electrical supply is restored after an electrical supply failure. Make sure that people do not get injured by the rotating blades of the pump.

If the electrical supply to the pump fails when the pump is in operation, the motor of the pump is used as a generator.

The regenerated power is used to:

- keep the output signals on the logic interface (such as the normal signal and serial communications)
- power the indicator LEDs on the motor controller
- keep the power at the motor controller auxiliary outputs (to control the vent valve or fan, if installed).

When the electronic braking is enabled, the regenerated power is available at the power supply pins of the logic interface connector (refer to [Electronic braking on page 14](#)). This can be used to power other instruments through short power interruptions. The minimum voltage of this supply will be 24 V d.c.-20% (19.2 V) provided that the external load is not excessive and it can be sustained at that minimum voltage when operating from supply voltages above 48 V d.c. -20% and below 48 V d.c. +5%.

As the rotational speed of the pump decreases, the power generated from the motor also decreases until it is no longer able to keep power to the logic interface or LEDs. This will occur at speeds less than 50% full rotational speed. There will be no indication of pump rotational speed, but the rotor can possibly continue to operate.

When the power is restored after a power failure, the behavior of the pump depends on the control mode at the time of failure (parallel or serial) and the duration of time the pump was without power. Refer to [Table: Behaviour of a pump when the power is re-instated after an electrical supply failure on page 80](#) for number of scenarios.

Table 26 Behaviour of a pump when the power is restored after an electrical supply failure

Length of power failure	Control mode	Behaviour of pump
Power is restored before the rotational speed of the pump decreases below 50%	Parallel or serial control mode	Regenerative power keeps all output signals active during the power failure. The pump will speed up to designated speed after the power has been restored.
Power is restored after the rotational speed of the pump decreases below 50% but before regenerative power stops	Parallel or serial control mode, timer disabled	Regenerative power keeps all output signals active during the power failure. As the timer is disabled, the motor controller will go to the fail condition when the speed decreases below 50% and will display flashing error code 0. When the power is restored, the pump will not speed up until the error is cleared. To clear the error, send a stop command (parallel or serial, depend on the control mode), send a start command to speed up the pump to the designated speed.
	Parallel or serial control mode, timer enabled	Regenerative power keeps all output signals active during the power failure. If power is restored before the timer period expires, the pump will speed up to designated speed. If the timer period expires, the motor controller will go into fail condition and will display flashing error code 3. When the power is restored, the pump will not speed up until the error is cleared. To clear the error, send a stop command (parallel or serial, depend on the control mode), send a start command to speed up the pump to the designated speed.
Power is restored after the rotational speed of the pump decreases below 50% and the regenerative power stops	Parallel or serial control mode	Regenerative power stops and fails to keep output signals. When power is restored, the pump with parallel control will automatically restart if the start control on the logic interface is set to start. The pump with serial control requires a new start command to speed up the pump to the designated speed. The fail signals caused during the regenerative power period are lost when the power is restored.

6.9 Bakeout

If the pump (and the vacuum system) are heated, the degassing process will speed up and the pump will reach ultimate vacuum in the shortest possible time. Heating the pump will also prevent condensation of vapours inside the pump.



WARNING: HOT SURFACE

Risk of burn. Do not touch the flange heater or surrounding surfaces during the bakeout process as they will be hot.



CAUTION: BAKEOUT PROCESS

Risk of damage to equipment. Pumps with ISO flanges are not suitable for bakeout, only pumps with CF flanges must be used. When baking the pump to above 70 °C at the inlet flange, the pump must be water cooled to prevent damage to the bearing lubricant.

The manufacturer's flange heater may be used to heat the pump (refer to [Accessories on page 101](#)). Fit the appropriate band around the pump CF inlet flange. When baking the pump or the system, make sure that the temperature of the inlet flange does not exceed the values given in [Table: General technical data on page 18](#).

When baking the vacuum system, if the temperature of the system exceeds 200 °C, put a radiation shield between the system and the pump. This radiation shield will reduce the heat radiated onto the pump rotor.

Typically, a bakeout of four hours is sufficiently long to remove water condensation from the pump. However, the bakeout time will depend on the amount of condensation in the pump and the vacuum system, and the ultimate pressure desired.

6.10 Shut down the pump manually

Note:

In an emergency only, open the vent valve quickly to decelerate the pump rotor in the shortest possible time.

Use this procedure to shut down a basic, manually-controlled pumping system with a manual vent valve.

1. Set the pump to off, but keep the backing-pump on and backing valve open.
2. When speed has fallen to 50%, open the vent valve.
3. When the pump reaches standstill, the vent valve and backing valve may be closed and backing pump set to off.

7. Maintenance

WARNING: PERSONAL PROTECTIVE EQUIPMENT



Risk of injury. Use personal protective equipment when you remove the pump to prevent injury from failed components and possible accumulation of hazardous materials. Check that the pump is vented to atmosphere at a safe temperature. Be careful of possible spillages, sharp edges and debris. Removal of the pump inlet screen will expose the risk of injury from sharp edges.

WARNING: MAINTENANCE SAFETY



Risk of injury. Allow the pump rotor to stop before you disconnect the logic interface cable from the power supply. Isolate other power sources. Remove the pump from the vacuum system for maintenance or fault finding procedures.

7.1 Bearing and oil cartridge maintenance

Replace the oil cartridge and oil-lubricated bearing when its service life ends. This is approximately after 35,000 hours.

When the oil cartridge or bearing are necessary to replace, we recommend you to:

- send the pump to our Service Centre for a bearing or oil cartridge replacement.
- purchase an oil cartridge or bearing service kit and replace the bearing or oil cartridge on-site.

Refer to [Service on page 97](#).

7.2 Rotor life

The fatigue life of Turbomolecular pump rotors is approximately 40,000 to 50,000 cycles. As a precautionary measure, we recommend you to return the pumps for a major service (rotor replacement) after 20,000 cycles of acceleration to full speed and back to a stop, or after ten years of use, whichever occurs first.

7.3 Cleaning the pump

CAUTION: CLEANING SOLUTIONS



Risk of damage to equipment. Clean the external surfaces of the pump in a well ventilated location. When using cleaning solutions and solvents to clean the pump, obey the precautions given by the manufacturer. Do not inhale particulates which can be in the pump.

Do not clean the parts of the pump other than external surfaces. Use of organic solvents can damage the internal pump components. Do not use abrasive materials to clean the pump parts.

If the inner side of the pump is contaminated, it is possible you will not get the necessary ultimate vacuum performance or the pump-down times can increase. Return the pump to our service centre for cleaning. Refer to [Return the equipment or components for service on page 97](#).

You can use the organic solvent to clean the external surface of the pump. We recommend you to use non-CFC solvents such as isopropanol or ethanol. Only small amount of a cleaning solution is necessary to clean the pump surface.

For environmental reasons, keep wastage of cleaning solutions and solvents to a minimum.

7.4 Decoding service status words

The service status can be accessed through the serial link. This method of accessing service status will give the most complete information of current and future service requirements and preventative maintenance activities can be scheduled.

A summary of the current pending service status is given in response to the service status command that follows:

<i>Command</i>	<i>?</i>	<i>v</i>	<i>8</i>	<i>8</i>	<i>1</i>	<i>cr</i>
----------------	----------	----------	----------	----------	----------	-----------

The reply is as follows:

<i>Reply</i>	<i>=</i>	<i>v</i>	<i>8</i>	<i>8</i>	<i>1</i>	<i>sp</i>	<i>h</i>	<i>h</i>	<i>h</i>	<i>h</i>	<i>h</i>	<i>h</i>	<i>h</i>	<i>h</i>	<i>h</i>	<i>cr</i>
--------------	----------	----------	----------	----------	----------	-----------	----------	----------	----------	----------	----------	----------	----------	----------	----------	-----------

The service status word is made up of 8 hexadecimal digits. To decode the word, convert each digit into a 4-digit binary number (same as the system status word, given in [Decoding system status words on page 91](#)).

Each binary digit (bit) represents a flag that is active (state 1) or not active (state 0). To help decode the service status word, each bit is numbered (starting with 0 for the least significant to 31 for the most significant) as shown in [Decoding system status words on page 91](#). The meaning of each bit in the service status word is given in [Flashing service codes on page 90](#).

Table 27 Service flags

Bit number	Status flag	Active flag means
0	Oil cartridge service due	Set when hours until oil cartridge service due = 0
1	Bearing service due	Set when hours until bearing service due = 0
2	Pump service due	Set when hours until pump service due = 0 or cycles until pump service due = 0
3	Controller service due	Set when hours until controller service due = 0
4	Reserved	-
5	Reserved	-
6	Reserved	-
7	Service due	Service is due. Specific operation necessary should be determined by checking the bits above

Bit number	Status flag	Active flag means
8 - 31	Reserved	-

7.5 Controller run time

The run hours and recommended service time of the controller on the pump can be monitored.

Send the query that follows:

Command	?	v	8	8	2	cr
---------	---	---	---	---	---	----

The reply is as follows (where, first number is the hours run by the controller and second is the number of hours until the service is recommended):

Reply	=	v	8	8	2	sp	d	d	d	d	d	d	;	d	d	d	d	d	d	cr
-------	---	---	---	---	---	----	---	---	---	---	---	---	---	---	---	---	---	---	---	----

 **Note:**

The number of hours until the next service is due is estimated by the controller based on the operating conditions of the pump and they can decrease at more or less than 1 hour per hour. Decreased pump temperature is the primary factor in extending the controller life.

7.6 Pump run time

The run hours and recommended service time of the rotor in the pump can be monitored.

Send the query that follows:

Command	?	v	8	8	4	cr
---------	---	---	---	---	---	----

The reply is as follows (where, first number is the start-stop cycles completed by the pump and second is the number of start-stop cycles until service is recommended):

Reply	=	v	8	8	4	sp	d	d	d	d	d	d	;	d	d	d	d	d	d	cr
-------	---	---	---	---	---	----	---	---	---	---	---	---	---	---	---	---	---	---	---	----

7.7 Pump cycles

The number of start-stop cycles completed and the number remaining until the next service is due can be monitored.

Send the query that follows:

Command	?	v	8	8	4	cr
---------	---	---	---	---	---	----

The reply is as follows (where, first number is the start-stop cycles completed by the pump and second is the number of start-stop cycles until service is recommended):

Reply	=	v	8	8	4	sp	d	d	d	d	d	d	;	d	d	d	d	d	d	cr
-------	---	---	---	---	---	----	---	---	---	---	---	---	---	---	---	---	---	---	---	----

7.8 Bearing run time

The run hours and recommended service time of the bearing in the pump can be monitored.

Send the query that follows:

<i>Command</i>	<i>?</i>	<i>v</i>	<i>8</i>	<i>8</i>	<i>5</i>	<i>cr</i>
----------------	----------	----------	----------	----------	----------	-----------

The reply is as follows (where, first number is the hours run by the bearing and second is the number of hours until service is recommended):

<i>Reply</i>	<i>=</i>	<i>v</i>	<i>8</i>	<i>8</i>	<i>5</i>	<i>sp</i>	<i>d</i>	<i>d</i>	<i>d</i>	<i>d</i>	<i>d</i>	<i>d</i>	<i>;</i>	<i>d</i>	<i>d</i>	<i>d</i>	<i>d</i>	<i>d</i>	<i>d</i>	<i>cr</i>
--------------	----------	----------	----------	----------	----------	-----------	----------	----------	----------	----------	----------	----------	----------	----------	----------	----------	----------	----------	----------	-----------

7.9 Oil cartridge run time

The run hours and recommended service time of the oil cartridge in the pump can be monitored.

Send the query that follows:

<i>Command</i>	<i>?</i>	<i>v</i>	<i>8</i>	<i>8</i>	<i>6</i>	<i>cr</i>
----------------	----------	----------	----------	----------	----------	-----------

The reply is as follows (where, first number is the hours run by the oil cartridge and second is the number of hours until service is recommended):

<i>Reply</i>	<i>=</i>	<i>v</i>	<i>8</i>	<i>8</i>	<i>6</i>	<i>sp</i>	<i>d</i>	<i>d</i>	<i>d</i>	<i>d</i>	<i>d</i>	<i>d</i>	<i>;</i>	<i>d</i>	<i>d</i>	<i>d</i>	<i>d</i>	<i>d</i>	<i>d</i>	<i>cr</i>
--------------	----------	----------	----------	----------	----------	-----------	----------	----------	----------	----------	----------	----------	----------	----------	----------	----------	----------	----------	----------	-----------

8. Fault finding

Table 28 Fault finding

Symptom
<i>The controller LEDs do not flash for 0.5 seconds when the system is set to on on page 86</i>
<i>The pump does not rotate after a parallel start command is sent on page 86</i>
<i>The pump does not rotate after a serial start command is sent on page 86</i>
<i>The pump does not respond in multi- drop mode on page 86</i>
<i>The green Normal LED does not light or the pump does not rotate at full speed or the pump fails while in operation on page 87</i>
<i>Ultimate pressure cannot be reached on page 87</i>
<i>The pump is very noisy or there is excessive vibration or both on page 88</i>
<i>No serial comms on page 88</i>
<i>Fail signal or standby signal not working on page 88</i>
<i>Yellow service LED is flashing a repeated sequence on page 89</i>
<i>The red alarm LED is on on page 89</i>
<i>The red alarm LED is flashing on page 89</i>
<i>Other problems on page 89</i>

Fault	The controller LEDs do not flash for 0.5 seconds when the system is set to on
Cause	The electrical supply has failed.
Remedy	Make sure that the electrical supply is set to on and the fuses (and current limiting devices) are not tripped.
Cause	The pump rotor is rotating.
Remedy	The LEDs can possibly not flash if the pump is in operation.
Fault	The pump does not rotate after a parallel start command is sent
Cause	Check that the electricity supply is on. Check if the fail output is active.
Remedy	If there is a fail signal, check if the red alarm LED is flashing. If yes, refer to <i>Flashing error codes on page 90</i> . If the power is supplied and fail signal is not given, but the rotor does not rotate, the fault is in the pump.
Fault	The pump does not rotate after a serial start command is sent
Cause	Check if the pump returns a reply to the start command.
Remedy	If there is no reply, do the checks given in <i>No serial comms on page 88</i> or do the checks given in <i>The pump does not rotate after a parallel start command is sent on page 86</i> .
Fault	The pump does not respond in multi- drop mode
Cause	The multi-drop is disabled.

Remedy Make sure the pump has a multi-drop address. Make sure that the commands are sent using the multi-drop protocol.

Fault The green Normal LED does not light or the pump does not rotate at full speed or the pump fails while in operation

Cause The inlet pressure is too high.

Remedy Decrease the pumping load or check for a gross leak in the system.

Cause The pump is too hot while in operation.

Remedy

- Increase the cooling of the pump. Change from air-cooling to water-cooling (refer to [Table: Pump performance data on page 30](#) for maximum inlet pressure and cooling requirements).
- Increase cooling water flow or decrease the water temperature or do both.
- Check that external heat sources (such as system bakeout heaters) are not excessive.

Cause The rotor does not rotate freely.

Remedy The pump bearings can be damaged. Contact us or the supplier.

Fault Ultimate pressure cannot be reached

Cause Pressure is limited by water vapour.

Remedy Bake the system and pump.

Cause The vacuum gauges are contaminated.

Remedy Clean or replace the vacuum gauges.

Cause Pumping speed is not sufficient (because of poor conductance between the pump and the gauge or the chamber is too large).

Remedy Increase the conductance or decrease the volume.

Cause Inlet pressure is more than 0.5 mbar (50 Pa).

Remedy If the interstage inlet pressure is too high, the inlet pressure at the turbomolecular inlet is increased. Make sure that the interstage inlet pressure is less than 0.5 mbar (50 Pa).

Cause The backing pressure is more than 10 mbar (1×10^3 Pa).

Remedy The backing pressure can be too high. Check for backing pipeline leaks. If the throughput is high, a larger backing pump can be necessary.

Cause The high vacuum area of the system is contaminated.

Remedy Clean the high vacuum system.

Cause Check the system for leaks and contamination.

Remedy If a leak is found, repair it and clean the contamination.

Cause The inlet pressure is less.

- Remedy
- Remove the pump from the system and test the ultimate pressure of the pump only.
 - Check the pump for contamination.
- Do the leak test of the pump. If the leak rate more than 1×10^{-7} mbar l s⁻¹ (1×10^{-5} Pa l s⁻¹), contact us or the supplier.

Fault The pump is very noisy or there is excessive vibration or both

Cause The rotational speed of the pump is same as the resonant frequency of the attached system.

Remedy Change the natural frequency of the system or isolate the pump using flexible bellows.

Cause The vibration is transmitting from the rotary backing pump.

Remedy Install a flexible bellows or a vibration isolator in the backing line.

Cause The noise is irregular and increasing.

Remedy A defective bearing. Contact us or the supplier.

Cause The pump makes a constant high pitched noise.

Remedy The rotor is out of balance. Contact us or the supplier.

Fault No serial comms

Cause No electrical supply, loss of serial link.

Remedy Check that:

- the electrical supply is on.
- the serial link is connected.
- the serial enable line is active.

Cause Slide switch is not in the correct position for RS232 or RS485.

Remedy Check that:

- the electrical supply is on.
- the serial link is connected.
- the serial enable line is active.
- Left for RS485, right for RS232.
- Right for parallel control and monitoring.

Cause Incorrect baud rate and node address.

Remedy Check baud rate and, if operating in multi-drop mode, the node address matches those of the pump.

Cause Check that the red light is not on or flashing.

Remedy If LED is on, check the red alarm LED symptoms.

Fault Fail signal or standby signal not working

Cause The serial enable line is not active.

Remedy Must be disconnected or driven high for use of standby and fail lines.

Cause Slide switch is not in the correct position for RS232 or RS485.

Remedy Left for RS485, right for RS232.
Right for parallel control and monitoring.

Fault Yellow service LED is flashing a repeated sequence

Cause A service is necessary.

Remedy Refer to [Flashing service codes on page 90](#).

Fault The red alarm LED is on

Cause The red alarm LED is on is normal during the software upgrade process.
At other times, if the red alarm LED is on it shows a problem is detected in the FLASH memory.

Remedy If software is upgrading, complete the upgrade process.
If the red alarm LED is on at other times:

- restart the system
- upgrade the software (if restarting the system does not correct the fault) .

Fault The red alarm LED is flashing

Cause A fail condition has activated.

Remedy Note the position of the long flashes in the series of 6 flashes to find the error code.
Refer to [Flashing error codes on page 90](#) and obey the instructions.

Fault Other problems

Cause Fault conditions other than previously mentioned.

Remedy Contact us or the supplier.

8.1 Command set error codes

Error codes that can be returned for serial control and monitoring.

Table 29 Command error codes

Returned error code	Meaning
0	No error
1	Invalid command for object ID
2	Invalid Query/Command
3	Missing parameter
4	Parameter out of range
5	Invalid command in current state - example: serial command to start or stop when in parallel control mode

8.2 Flashing service codes

When a service is necessary, the standard once per revolution flash on the yellow status LED is changed to a service flash code.

Table 30 Flashing service codes

Service flash code	Comments	Actions
LED on 1sec LED off 1sec	Oil cartridge service recommended	We recommend you to replace the oil cartridge. Refer to Bearing and oil cartridge maintenance on page 82 .
LED on 3sec LED off 1sec	Bearing and oil cartridge service recommended	We recommend you to replace the bearing and oil cartridge. Refer to Bearing and oil cartridge maintenance on page 82 .
LED on 3sec LED off 3sec	Pump service necessary	The turbo impeller or controller has reached its service life. We recommend you to return the pump to our service centre for service. Refer to Bearing and oil cartridge maintenance on page 82 .

8.3 Flashing error codes

When a fail condition becomes active, the red alarm lights continuously or shows a flashing sequence.

If the error light is on continuously, this shows a problem with the embedded software. Restart the system. If restarting the system does not clear the fault, a software download is necessary. Contact us or the supplier. If the alarm LED is flashing, identify the error flash code and refer to the table in [Decoding system status words on page 91](#).

Sufficient off period is there between each subsequent cycle repetition to mark the start of a new flash sequence. The duration of a long flash (L) is equal to 3 times the duration of a short flash (0.5 s).

Table 31 Flashing error codes

Error flash position	Error flash code	Comments	Actions
0	ssssss	The speed decreases below 50% of the full rotational speed with the Timer disabled.	Check if the pump is too hot or if the inlet pressure is too high.
1	Lsssss	Controller internal software mismatch	Restart the system. If the error code is not cleared, contact us or the supplier.
2	sLssss	Controller failed internal configuration and calibration operation	Restart the system. If the error code is not cleared, contact us or the supplier.
3	ssLsss	Fail to reach or hold half full speed in the timer setting value	Check if the pump is too hot or if the inlet pressure is too high.

Error flash position	Error flash code	Comments	Actions
4	ssSLss	Overspeed or overcurrent trip is activated, or other hardware fault	Restart the system. If the error code is not cleared, contact us or the supplier.
5	ssssLs	Pump internal measurement system is disconnected or damaged	Restart the system. If the error code is not cleared, contact us or the supplier.
6	ssssSL	Serial enable becomes inactive after a Serial Start command	Activate the Serial Enable again and send a Serial Stop command to clear the error code.

 **Note:**

The alarm LED error flash sequence is capable of signaling multiple fail conditions. For example, error flash code sLssLs signifies error 2 (controller failed internal configuration and calibration operation) and error 5 (pump internal measurement system disconnected or damaged).

8.4 Decoding system status words

When you use the serial communications link, additional information that can be useful for the fault finding can be accessed. When sending a query to monitor measured motor speed, the pump also returns a System Status Word.

The send command that follows:

Command	?	v	8	5	2	cr
---------	---	---	---	---	---	----

The reply is as follows (where, first returned number refers to motor rotational speed in revolutions per second (Hz) and second part is the system status word):

Reply	=	v	8	5	2	sp	d	d	d	d	;	h	h	h	h	h	h	h	h	cr
-------	---	---	---	---	---	----	---	---	---	---	---	---	---	---	---	---	---	---	---	----

The System Status Word returned is made up of 8 hexadecimal digits. To decode this word, convert each digit into a 4-digit binary number. Example:

2	2	8	3	0	0	2	2
↓	↓	↓	↓	↓	↓	↓	↓
0 0 1 0	0 0 1 0	1 0 0 0	0 0 1 1	0 0 0 0	0 0 0 0	0 0 1 0	0 0 1 0

Refer to [Table: Hexadecimal conversion table on page 91](#) for more information.

Table 32 Hexadecimal conversion table

Hexadecimal	Binary	Decimal
0	0000	0
1	0001	1
2	0010	2
3	0011	3
4	0100	4
5	0101	5

Hexadecimal	Binary	Decimal
6	0110	6
7	0111	7
8	1000	8
9	1001	9
A	1010	10
B	1011	11
C	1100	12
D	1101	13
E	1110	14
F	1111	15

Each binary digit (bit) represents a flag that is active (state 1) or not active (state 0). To help decode the System Status Word, each bit is numbered (starting with 0 for the least significant to 31 for the most significant) as shown below.

Refer to [Table: Status flags on page 92](#) for the list of the lower 16 status flags that are useful for fault finding. The upper 16 status flags are reserved by us.

Binary digits																															
0	0	1	0	0	0	1	0	1	0	0	0	0	0	0	1	1	0	0	0	0	0	0	0	0	1	0	0	0	1	0	
↓	↓	↓	↓	↓	↓	↓	↓	↓	↓	↓	↓	↓	↓	↓	↓	↓	↓	↓	↓	↓	↓	↓	↓	↓	↓	↓	↓	↓	↓	↓	
3	3	2	2	2	2	2	2	2	2	2	2	2	1	1	1	1	1	1	1	1	1	1	1	1	0	0	0	0	1	0	
1	0	9	8	7	6	5	4	3	2	1	0	9	8	7	6	5	4	3	2	1	0	9	8	7	6	5	4	3	2	1	0
Bit numbers																															

Table 33 Status flags

Bit number	Status flag	Active flags means
0	Fail	Fail status condition active
1	Stopped speed	Below stopped speed
2	Normal speed	Above normal speed
3	Vent valve closed	Vent valve energised
4	Start	Start command active
5	Serial enable	Serial enable active
6	Standby	Standby active
7	Half full speed	Above 50% full rotational speed
8	Parallel control mode	Exclusive control mode selection
9	Serial control mode	Exclusive control mode selection
10	Invalid Controller software	Controller internal software mismatch
11	Controller upload incomplete	Controller failed internal configuration and calibration operation
12	Timer expired	Failure to reach or maintain half full speed in the timer setting value
13	Hardware trip	Overspeed or overcurrent trip activated

Bit number	Status flag	Active flags means
14	Thermistor error	Pump internal temperature measurement system disconnected or damaged
15	Serial control mode interlock	Serial enable has become inactive following a serial Start command

Table 34 The system status word used in the example above was taken when the pump is not in operation. Decode the word for more information about the state of the pump.

Table 35 Example decoding of system status words

Bit number	Status of bit (in example)	Indication
0	0	The pump has not failed
1	1	The pump is at rest
2	0	Speed is below normal speed
3	0	The vent valve is open
4	0	There is no active start command
5	1	Serial enable is active
6	0	Standby is not active
7	0	Speed is below 50% of full rotational speed
8	0	The pump is not in parallel control mode
9	0	The pump is not in serial control mode
10	0	There is no controller internal software mismatch
11	0	Controller passed internal configuration and calibration operation
12	0	The timer has not timed out
13	0	Overspeed and overcurrent trip not activated
14	0	Pump internal temperature measurement system is fine
15	0	Serial enable has not become inactive during serial control

8.5 Service information

If you use the serial communications link, additional information about the pump (such as pump type and internal controller software versions) can be accessed. This information is useful for the service personnel to select the model of the pump.

Send the query that follows to find out the pump type:

Command	?	s	8	5	1	cr
---------	---	---	---	---	---	----

The reply is as follows (where, String 1 is the pump type, String 2 is the DSP software version number and String 3 (in revolutions per second)):

B8G000880_D - Fault finding

<i>Reply</i>	=	<i>s</i>	<i>8</i>	<i>5</i>	<i>1</i>	<i>sp</i>	<i>String 1</i>	;	<i>String 2</i>	;	<i>String 3</i>	<i>cr</i>
--------------	---	----------	----------	----------	----------	-----------	-----------------	---	-----------------	---	-----------------	-----------

Send the query that follows to find out the PIC software version:

<i>Command</i>	?	<i>s</i>	<i>8</i>	<i>6</i>	<i>8</i>	<i>cr</i>
----------------	---	----------	----------	----------	----------	-----------

The reply is as follows (where, String 1 is the PIC software version number):

<i>Reply</i>	=	<i>s</i>	<i>8</i>	<i>6</i>	<i>8</i>	<i>sp</i>	<i>String 1</i>	<i>cr</i>
--------------	---	----------	----------	----------	----------	-----------	-----------------	-----------

9. Storage

If possible, do not store the pump for long-term. When long-term storage is necessary, the pump should be set up and operated for a minimum of eight hours every six months.

To store the pump:

1. Put protective covers over all ports, the main inlet, inter-stage exhaust, purge and vent ports.
2. Put the pump in its packing materials. Seal the pump in a plastic bag with a applicable desiccant for fastest pump-down when the pump is put back into service.
3. Store the pump in cool, dry conditions. Make sure that the pump is not exposed to atmospheric air until necessary for use.
4. When necessary, prepare and install the pump as given in [Installation on page 35](#).
5. Keep the pump upright at all times to prevent the drainage of oil from the bearing reservoir.

10. Disposal



WARNING: PERSONAL PROTECTIVE EQUIPMENT

Risk of exposure to harmful substances. If the pump rotor fails, there can be some dust created from the rotary components in the pump touching each other. Use correct personal protective equipment when handling and disposing the pump. Make sure that all pump inlets and outlets are capped off before disposal.

Do not inhale the particulates which can be in the pump. Do not incinerate the pump.

A HS2 form must be completed if returning the pump to us.

Dispose of the pump, components and accessories safely and in accordance with all local and national safety and environmental requirements.

Be careful with the components that have been contaminated with dangerous process substances.

The pump contains phenolic and fluorosilicone materials that can decompose to very dangerous substances when heated to high temperatures.

11. Service

Note:

Our policy is to give support for product after obsolescence through various options including maintenance, repair, enhancement and replacement. Support will be available for some years after the product obsolescence and in compliance with applicable legislation. We will always undertake applicable actions to keep support, where support is no longer possible, we will make sure this is communicated to all affected customers with a notice period.

Our products, spares and accessories are available from our companies in Belgium, Brazil, China, France, Germany, Israel, Italy, Japan, Korea, Singapore, United Kingdom, U.S.A and a world-wide network of distributors. The majority of these centres employ service engineers who have undergone our comprehensive training courses.

Order spare parts and accessories from our nearest company or distributor. When you order, give:

- Model and Item Number of the equipment
- Serial number
- Item Number and description of part.

Our products are supported by a world-wide network of our Service centres. Each Service centre offers a wide range of options that include: equipment decontamination, service exchange, repair, rebuild and testing to factory specifications. Equipment which has been serviced, repaired or rebuilt is returned with a full warranty.

The local Service Centres can also give our engineers to support on-site maintenance, service or repair of equipment. For more information about service options, contact our nearest Service Centre or the company.

11.1 Return the equipment or components for service

Before you send your equipment to us for service or for any other reason, you must send us a completed Declaration of Contamination of Vacuum Equipment and Components – Form HS2. The HS2 form tells us if any substances found in the equipment are hazardous, which is important for the safety of our employees and all other people involved in the service of your equipment. The hazard information also lets us select the correct procedures to service your equipment.

We provide instructions for completing the form in the Declaration of Contamination of Vacuum equipment and Components – Procedure HS1.

If you are returning a vacuum pump, note the following:

- If a pump is configured to suit the application, make a record of the configuration before returning the pump. All replacement pumps will be supplied with default factory settings.
- Do not return a pump with accessories fitted. Remove all accessories and retain them for future use.
- The instruction in the returns procedure to drain all fluids does not apply to the lubricant in pump oil reservoirs.

Download the latest documents from www.edwardsvacuum.com/HSForms/, follow the procedure in HS1, fill in the electronic HS2 form, print it, sign it, and return the signed copy to us.

**NOTICE:**

If we do not receive a completed HS2 form, your equipment cannot be serviced.

11.2 Bearing and oil cartridge on-site maintenance

The oil cartridge and bearing of the pump can be serviced on-site by a service engineer trained by us.

The service tool kits and service parts that follows are available.

Table 36 Service tool kits

Service tool kit	Item number
Bearing exchange tooling kit	B8G200845

Table 37 Service kits

Service kit	Item number
Oil cartridge	B8G200828
Bearing and oil cartridge	B8G200811

 **Note:**

The oil cartridge and bearing kits are necessary when changing a pump bearing. Refer to the Bearing Service Tool Kit instruction manual B8G200840 for how to service the oil cartridge and bearing.

12. Spares



CAUTION: SUPPLIED SPARES

Risk of damage to equipment. If you use spares that are not supplied by us, it will decrease the reliability and performance of the pump. This will also invalidate the product warranty.

12.1 Inlet screen

Inlet screens are installed to the pumps as supplied to prevent damage from the entry of debris into the pump.

Table 38 Inlet screens

Flange Size	Item Number
DN63CF (10 off kit)	B72240807
DN63CF (1 off kit)	B72240860

12.2 Inlet strainer

The interstage pumps are supplied with an inlet strainer for the interstage port.

Table 39 Inlet strainers

Flange Size	Inlet Screen
DN25ISO-K	A22305067

12.3 Inlet flange seals and integrated inlet screens

The pumps are supplied with an inlet seal.

Table 40 Inlet flange seals and integrated inlet screens

Flange size	Inlet flange seal	Item number
DN100ISO-K	ISO100 trapped O-ring with integrated coarse inlet screen	B81000808
DN100ISO-K	ISO100 trapped O-ring with integrated fine inlet screen	B81000809
DN63ISO-K	ISO63 trapped O-ring with integrated coarse inlet screen	B8G200808
DN63ISO-K	ISO63 trapped O-ring with integrated fine inlet screen	B8G200809
NW40	NW40 centring o-ring with integrated coarse inlet screen	C10516085

12.4 NW16 and NW25 ports

The pumps are supplied with a NW16 backing port and a NW16 or NW25 interstage port.

Table 41 NW16 and NW25 ports

Port	Item Number
NW25	B80000809
NW16	B80000806

13. Accessories

Figure 23 Accessories

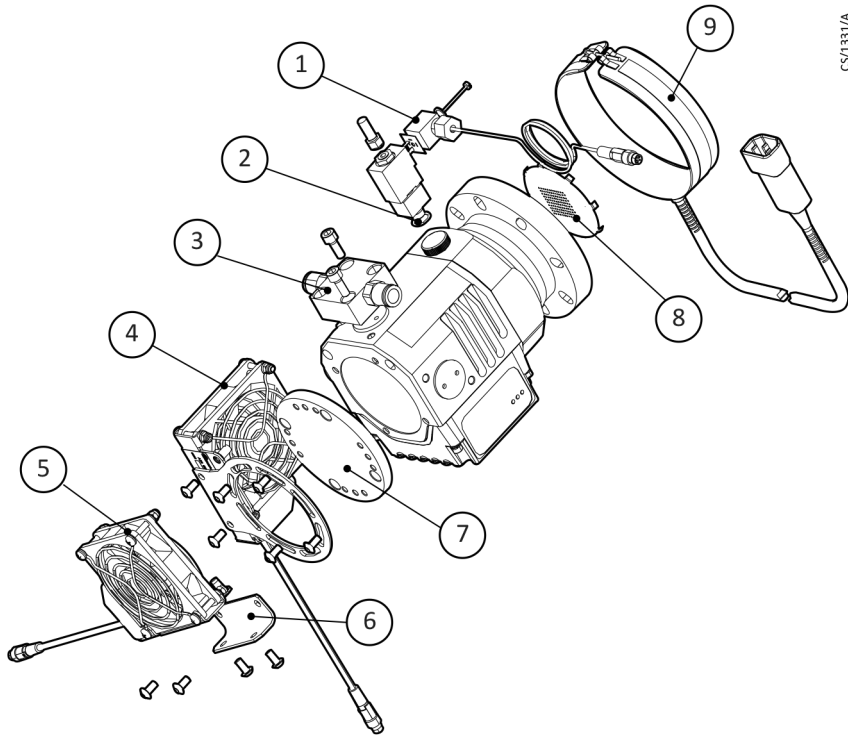

- | | |
|---|---|
| <ul style="list-style-type: none"> 1. TAV Solenoid vent-valve 3. nEXT85 water cooler 5. ACX85 Axial air cooler 7. Base mounting adaptor | <ul style="list-style-type: none"> 2. Manual vent-valve (fitted) 4. ACX85 Radial air cooler 6. ACX85 Axial air cooler mounting bracket 8. Inlet screen (CF63 shown) 9. Flange heater |
|---|---|

13.1 Air cooler

The air coolers are available with a pre-wired connector which connects to an auxiliary port on the controller or with a bare wire.

An air cooler can be installed to the pump. Refer to [Forced air cooling on page 56](#) to check the correct air-cooling in a particular application. The air coolers are pre-wired to Vent Option 2 and the default is set to Always On (option 8).

Table 42 Air cooler

Air Cooler	Current draw	Item number
nEXT85 Air cooler kit - wired	150 mA	B8G200820
nEXT85 Air cooler kit - bare wire	150 mA	B8G200821

13.2 Water cooler

A water cooler can be installed to the pump if the water supply is applicable.

Refer to [Forced air cooling on page 56](#) to check the applicable water-cooling supply.

Table 43 Water cooler

Water Cooler	Item Number
nEXT85 water cooler	B8G200833

13.3 Flange heater

A flange heater increases the degassing of the pump to enable it to achieve lower pressures. It can also be used to protect the pump from condensation of contaminants. The flange heaters are available in 110 V and 240 V versions.

 **Note:**

Use the flange heater only with CF variants.

Table 44 Flange heater

Water Cooler	Item Number
nEXT85 (110 V) flange heater	B8G200823
nEXT85 (240 V) flange heater	B8G200824

13.4 TAV5 vent valve

A 24 V d.c. TAV5 solenoid-operated vent valve options are available for system venting. These are normally open (N/O) or normally closed (N/C).

The valves are available with either a wired connector which connects directly to the auxiliary port on the controller or as a bare wire option.

All vent valves have an 0.5 mm diameter orifice and are applicable to vent small vacuum systems of less than 5 litres.

The vent valves are pre-wired to Vent Option 1 and the default is set to fully vent at 50% (option 0). The solenoid valve is installed in place of the manual valve, or can be installed with an adaptor (supplied with the valve). Use the valves with an applicable NW10 flanged port on the vacuum system. The vent port adaptor lets the vent port or the purge port to be used with an applicable NW10 fitting.

Table 45 TAV vent valve and vent port adaptor

Product	Item Number
nEXT85 TAV5 kit N/C connector fitted (0.3 m)	B8G200835
nEXT85 TAV5 kit N/C bare wire (3 m)	B58066040
nEXT85 TAV5 kit N/O connector fitted (0.3 m)	B8G200834
nEXT85 TAV5 kit N/O bare wire (3 m)	B58066010

13.5 VRX vent restrictor

Use a VRX installed orifice vent restrictor to restrict the flow of vent gas into the pump.

Table 46 VRX vent restrictor

Vent restrictor	Orifice diameter (mm)	Item number
VRX10	0.1	B58066021
VRX20	0.2	B58066022
VRX30	0.3	B58066023
VRX50	0.5	B58066024
VRX70	0.7	B58066025

13.6 Vent port adaptor

The vent port adaptor has a 1/8 inch BSP male thread that can be screwed in the vent port and purge port which makes them applicable for NW10 fittings.

Table 47 Vent port adaptor

Vent port adaptor	Item Number
Vent port adaptor NW10 - 1/8 inch BSP male	B58066011

13.7 PRX purge restrictor

The PRX10 is a modified DN10NW centring ring that filters the purge gas and restricts its flow rate to the recommended flow of 25 sccm. Install a vent port adaptor to the purge port to connect a purge restrictor to the pump.

Table 48 PRX purge restrictor

Item	Item Number
PRX10 purge restrictor	B58065001

13.8 Interface cable

An interface cable connects the pump to a PC. Serial commands are used to control and monitor the pump.

Table 49 Interface cable

Item	Item Number
nEXT Interface cable	B80000808

13.9 nST PC program

The nST PC program is PC-based software that can be used with the pump through the serial interface or through the USB service port.

You can use the nST PC program to:

- control the pump
- monitor the pump
- configure the pump

- data log the pump
- view service status
- reset service intervals
- upgrade the software embedded in the motor controller.

The software is available for download from the manufacturer's website: www.upgrades.edwardsvacuum.com

A free license is necessary to use the nST software. To get a free license:

- obey the on-screen instructions
- fill out the user data form
- send the automatically generated email to us.

13.10 Auxiliary connector

The auxiliary connector enables the use of accessories that are not pre-wired with a mating plug. Cable length is 1.5 m.

Table 50 Auxiliary connector



Item	Item Number
nEXT85 auxiliary connector	B8G200839

13.11 Auxiliary extension cable

The cable extends the distance of the accessory to the pump. A right angled plug is given for installation where space is small. Cable length is 0.2 m.



Table 51 Auxiliary extension cable

Item	Item Number
nEXT85 auxiliary extension cable	B8G200836

13.12 Auxiliary 'Y' cable adaptor

The auxiliary 'Y' cable adaptor enables:

- a TAV5 vent valve and a cooling fan or
- two cooling fans or
- 2 TAV5 vent valves to be operated at the same time.

The two sockets of the Y-cable are wired in parallel so an applicable connector can be used in the same way as the auxiliary connector on the pump.



Table 52 Auxiliary extension cable

Item	Item Number
nEXT85 auxiliary 'Y' cable adaptor	B8G200837

13.13 Base mounting adaptor

A base mounted adaptor is available to enable the pump to be mounted in the same position as an EXT75DX pump.

Table 53 Base mounting adaptor

Item	Item Number
nEXT85 base mounting adaptor	B8G200838

This page has been intentionally left blank.

