

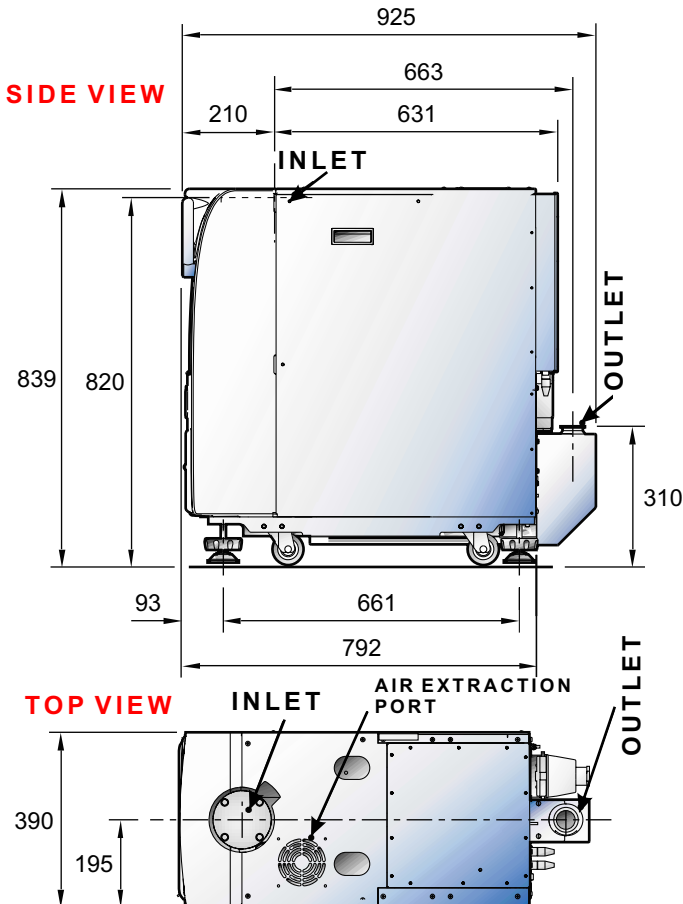

## Dimensions iL600N



# EDWARDS

© Edwards Limited 2008. All rights reserved.

## iL600N DRY PUMP SYSTEM

### SPECIFICATIONS

<b>Peak Speed</b>	<b>cfm</b>	60 Hz	50 Hz
	<b>M<sup>3</sup>h<sup>-1</sup></b>	353	305
	<b>1 min<sup>-1</sup></b>	600	518
<b>Ultimate Vacuum (with shaft seal purge)</b>	<b>torr</b>	1.5X10 <sup>-3</sup>	2.3X10 <sup>-3</sup>
	<b>mbar</b>	2X10 <sup>-3</sup>	3X10 <sup>-3</sup>
	<b>Pa</b>	0.2	0.3
<b>Typical Shaft Seal nitrogen flow</b>	<b>slm</b>	4	4
<b>Inlet Connection</b>	ISO100		
<b>Outlet Connection</b>	NW40		
<b>Typical cooling water flow at 15psi drop</b>	<b>1 h<sup>-1</sup></b>	150	
	<b>1 min<sup>-1</sup></b>	2.5	
<b>Weight</b>	<b>kg/lbs.</b>	405/891	
<b>Power input</b>	<b>kW</b>	2.0	1.8
<b>Rated motor</b>	<b>kW</b>	4.4	3.6
<b>Oil Capacity</b>	<b>liter</b>	1.5	

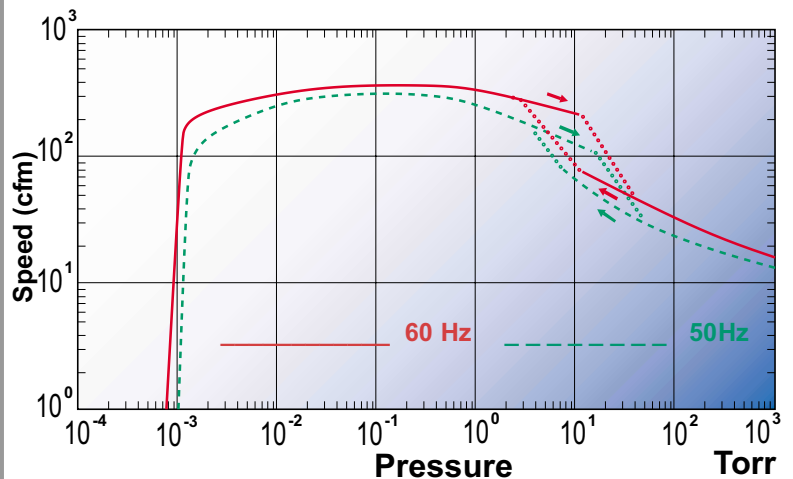

iL600N Pumping Speed Curve

**90 DAY WARRANTY  
ON ALL PARTS & LABOR**