

# Titan 300L Ion Pump

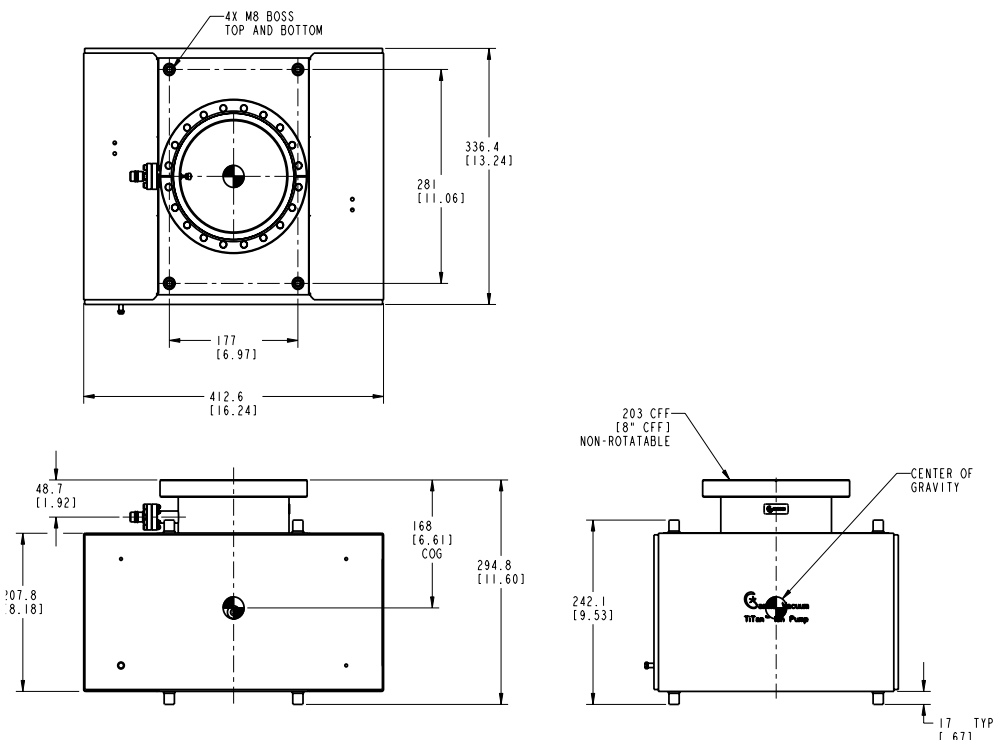

## DIMENSIONAL DETAILS\*



# Technical specifications

Element type	CV/CVX	DI/DIX	TR
Pumping speed (l/s, Nitrogen)	300	240	240
Starting pressure (mbar)	$\leq 1 \times 10^{-3}$	$\leq 1 \times 10^{-3}$	$\leq 5 \times 10^{-2}$
Lifetime (hours @ $10^{-6}$ mbar)	50,000	50,000	80,000
Ultimate pressure (mbar)	$\leq 1 \times 10^{-11}$		
Maximum baking temperature (°C)	250 / 450 (without magnets)		
Inlet flange	DN 150 (8 in.) CFF		
Weight, kg (lbs)	66 (145)		

## STANDARD OPTIONS\*

Element type	Ports	Feedthroughs	Heaters	TSP/NEG
CV Conventional 100% Titanium	8S Single DN 150 (8 in. CFF)	SC SAFECONN 10kV SHV	N No heaters	N Not Installed
CVX Conventional XHV optimized	8D Double DN 150 (8 in. CFF)	OP Perkin Elmer	110 110-volt 90-130 nominal	TSPA TSP with Ambient Shield
DI Differential 50% Titanium 50% Tantalum		OV Old Varian	220 220-volt 200-240 nominal	TSPC TSP with Cryo Shroud
DIX Differential XHV optimized		VR StarCell		NEG N Series
TR Triode Slotted Titanium		FI Fisher		

\*Configured part numbers and pricing are available at [www.gammavacuum.com](http://www.gammavacuum.com). Contact us directly for custom engineered options.

## PERFORMANCE CHARACTERISTICS

### Pumping Speed vs. Pressure

measured in accordance with ISO/DIS 3556-1.2-1192

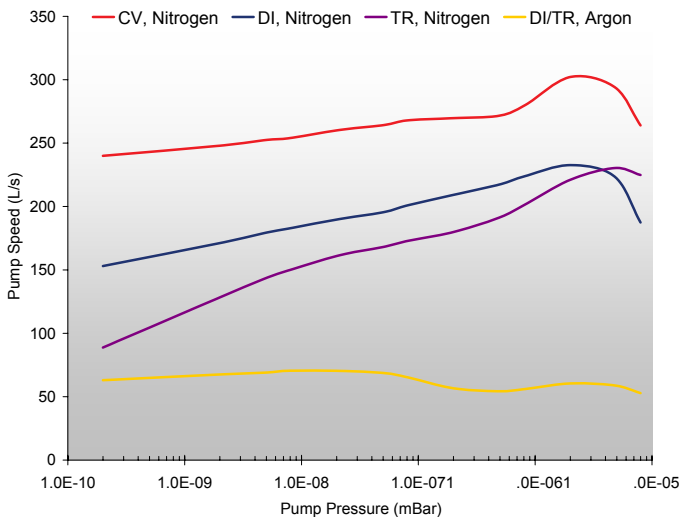

### Current vs. Pressure

