

Titan 10ST Ion Pump

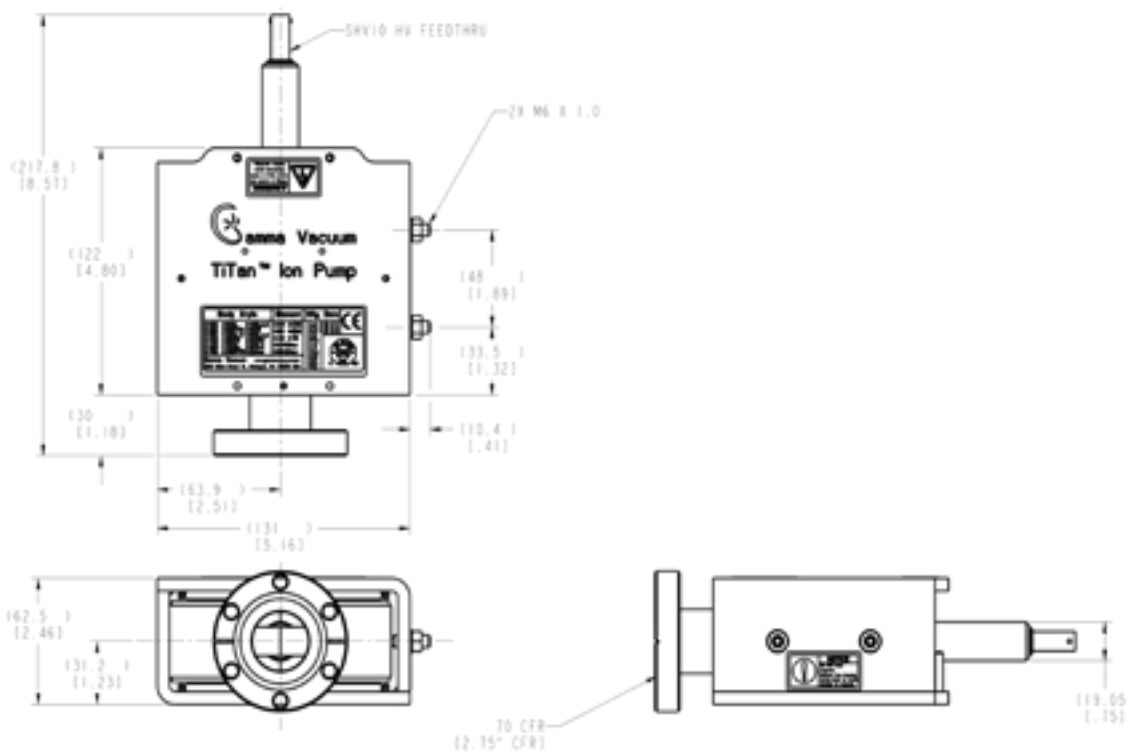

DIMENSIONAL DETAILS*



Technical specifications

Element type	CV/CVX	DI/DIX
Pumping speed (l/s, Nitrogen)	10	8
Starting pressure (mbar)	$\leq 1 \times 10^{-3}$	$\leq 1 \times 10^{-3}$
Lifetime (hours @ 10^{-6} mbar)	50,000	
Ultimate pressure (mbar)	$\leq 1 \times 10^{-11}$	
Maximum baking temperature (°C)	80 / 450 (without magnets)	
Inlet flange	DN 35 (2.75 in.) CFR	
Weight, kg (lbs)	4 (9)	

*The 10ST is a thin version of the standard 10SW. The magnets are rare earth materials and not bakeable.

STANDARD OPTIONS*

Element type	Ports	Feedthroughs	Heaters	TSP/NEG
CV Conventional 100% Titanium	2H Single DN 35 (2.75 in. CFR) Horizontally oriented	SC SAFECONN 10kV SHV	N No heaters	N Not available
DI Differential 50% Titanium 50% Tantalum		OV Old varian		
		FI Fisher		

*Configured part numbers and pricing are available at www.gammavacuum.com. Contact us directly for custom engineered options.

PERFORMANCE CHARACTERISTICS

Pumping Speed vs. Pressure

measured in accordance with ISO/DIS 3556-1.2-1192

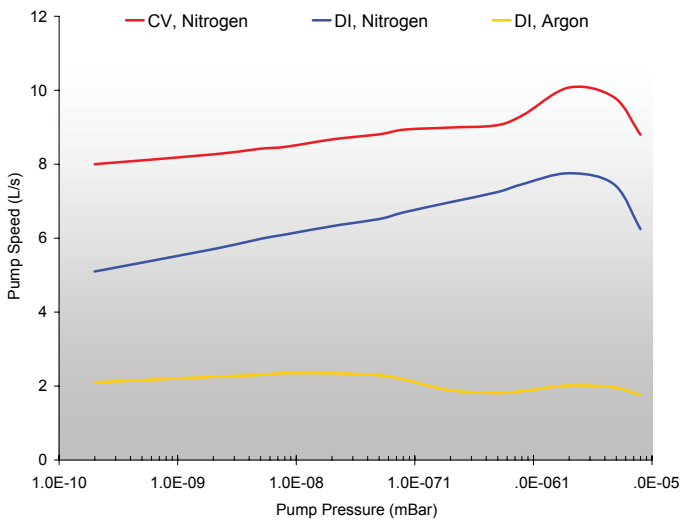

Current vs. Pressure

