



PRG20K AND PRG20KCR PASSIVE PIRANI GAUGE INSTRUCTION MANUAL

Publication number: D0300020001EN

Issue: A

Original Instructions



Declaration of Conformity

We, Edwards,
Innovation Drive,
Burgess Hill,
West Sussex,
RH15 9TW, UK

declare under our sole responsibility, as manufacturer and person within the EU authorised to assemble the technical file, that the product(s)

- Pirani (PRG) gauges connected to controllers (PGC).

D03000200	PRG20K - NW16 AI
D03000210	PRG20K - DN16CF SS
D03000220	PRG20KCR - NW16 SS
D03000400	PGC201 Pirani/Penning Contr +*
D03000410	PGC202 Pirani/Ion Contr +*

D03000201	PRG cable 5 m
D03000202	PRG cable 10 m
D03000203	PRG cable 20 m
D03000204	PRG cable 30 m
D03000205	PRG cable 50 m

to which this declaration relates is in conformity with the following standard(s) or other normative document(s)

EN61010-1:2010	Safety Requirements for Electrical Equipment for Measurement, Control and Laboratory Use. General Requirements
EN61326-1:2013 Class B, Industrial	Electrical equipment for measurement, control and laboratory Use. EMC requirements. General requirements

and fulfils all the relevant provisions of

(+) 2014/35/EU	Low Voltage Directive
(*) 2014/30/EU	Electromagnetic Compatibility (EMC) Directive
2011/65/EU	Restriction of Certain Hazardous Substances (RoHS) Directive
2012/19/EU	Waste from Electrical and Electronic Equipment (WEEE) Directive

Note: This declaration covers all product serial numbers from the date this Declaration was signed onwards.

Larry Marini, Senior Technical

07.06.2017, Eastbourne

Date and Place

This product has been manufactured under a quality management system certified to ISO 9001:2008

This page intentionally blank.

Copyright notice

© Edwards Limited 2017. All rights reserved.

Trademark credits

Edwards and the Edwards logo are trademarks of Edwards Limited.

Contents

Safety	1
Symbols used	1
Symbols for residual risks	1
Personnel qualifications	1
General safety instructions	1
Responsibility and warranty	2
Description	3
Product identification	3
Validity	3
Intended use	3
Unpacking and Checking	4
Scope of delivery	4
Technical data	5
PRG20K gauge head NW16	5
PRG20K gauge head DN16CF	5
PRG20KCR gauge head NW16	6
Installation	7
Supplied equipment	7
Connection of the gauge head	7
Adjustment of the gauge head	8
Adjustment of the gauge head in connection with operating units PGC201 and PGC202	8
Maintenance	9
Exchanging the sensing cell	9
Spare parts and accessories	11
Spares	11
Accessories	11
Storing and waste disposal	12
Storage	12
Disposal	12
Returning the product	13
Disposal	14
Separating the components	14
Contaminated components	14
Other components	14

List of Figures

Dimensions	6
Gauge head PRG20K - NW16 Al / PRG20K - DN16CF SS / PRG20KCR - NW16 SS	8
Disassembled PRG20K - NW16 Al / PRG20K - DN16CF SS / PRG20KCR - NW16 SS gauge head	10

Safety

Symbols used

Symbols for residual risks



WARNING:

Warnings are given where failure to observe the instruction could result in injury or death to people.



CAUTION:

Cautions are given where failure to observe the instruction could result in damage to the equipment, associated equipment and process.



Note:

Information on correct handling or use. Disregard can lead to malfunctions or minor equipment damage.

Personnel qualifications

All work described in this document may only be carried out by persons who have suitable technical training and the necessary experience or who have been instructed.

General safety instructions

- Adhere to the applicable regulations and take the necessary precautions for the process media used.
- Consider possible reactions with the product materials.
- Consider possible reactions (for example, explosion) of the process media due to the heat generated by the product.
- Adhere to the applicable regulations and take the necessary precautions for all work to be performed and consider the safety instructions in this document.
- Ensure that all vacuum components have not been contaminated before beginning any work. If so, adhere to the relevant regulations and take the necessary precautions when handling contaminated parts.
- The PRG heads must only be operated with Edwards PGC201 or PGC202 vacuum gauge controller instruments.

Communicate the safety instructions to all other users.

Responsibility and warranty

Edwards will not assume any responsibility or warranty in cases where the operator or third persons:

- Do not observe the information given in this document.
- Do not use the product as intended.
- Modify the product in any way (conversions, repair work, etc.).
- Operate the product with accessories not listed in the corresponding product documentation.

Subject to technical alterations without prior notice. The figures are not binding.

Description

The PRG are vacuum gauge heads.

The actual pressure sensing element within the gauge head PRG20K - NW16 is a tungsten filament.

The PRG gauge heads PRG20K - DN16CF and PRG20KCR - NW16 are made of stainless steel with a welded ceramics feed-through. The sensing element within the PRG20K - NW16 is a tungsten filament, whereas the PRG20KCR - NW16 uses a platinum filament.

The gauge heads are supplied fully aligned. Any alignment or recalibration will, if at all necessary, be required only after a longer period of operation.

The gauge heads are temperature compensated for the range from 0 °C to 40 °C.

The measurement cells can be easily exchanged should this be required. After an exchange of the sensing cell a recalibration is required by adjusting two potentiometers within in the gauge head.

Product identification

In all communications with Edwards, please specify the information on the product nameplate.

Validity

This document applies to products with part numbers

Product Description	Item number
PRG20K NW16 AL	D03000200
PRG20K DN16CF SS	D03000210
PRG20KCR NW16 SS	D03000220
PRG cable 5m	D03000201
PRG cable 10m	D03000202
PRG cable 20m	D03000203
PRG cable 30m	D03000204
PRG cable 50m	D03000205

The part number (No:) can be taken from the product nameplate.

Intended use

The PRG gauge heads are vacuum gauge heads which are operated in connection with the operating units PGC201 and PGC202.

The gauge head is used for the measurement of absolute pressures in the rough and fine vacuum range in accordance with the technical data.

Unpacking and Checking

Unpack the PRG gauge head immediately after delivery, even if it is to be installed at a later date.

Retain the packaging materials in the event of complaints about damage.

Carefully examine the visually. If any damage is discovered, report it immediately to the forwarding agent and insurer. If the gauge head has to be replaced, contact the orders department.

Scope of delivery

- PRG gauge head
- Securing bow for connection plug

Technical data

PRG20K gauge head NW16

Measurement range	0.5 x 10 ⁻⁴ to 1 x 10 ³ mbar
Filament temperature	110 °C
Disruption pressure (Burst pressure) (absolute)	3 bar
Measurement volume	11 cm ³
Connection flange	NW16
Filament material	Tungsten
Material in contact with the medium	Aluminium, glass, Vacon, Tungsten, chrome-nickel 8020, steel nickel-plated, Epoxy adhesive
Operating temperature	0 to 40 °C
Maximum ambient temperature	80 °C

PRG20K gauge head DN16CF

Measurement range	0.5 x 10 ⁻⁴ to 1 x 10 ³ mbar
Filament temperature	110 °C
Disruption pressure (Burst pressure) (absolute)	10 bar
Measurement volume	10 cm ³
Connection flange	DN 16 CF
Filament material	Tungsten
Material in contact with the medium	Stainless steel 1.4301, Tungsten, chrome nickel 8020, ceramics Al ₂ O ₃ , NiFe 42
Operating temperature	0 to 40 °C
Maximum ambient temperature	80 °C

PRG20KCR gauge head NW16

Measurement range	0.5 x 10 ⁻⁴ to 1 x 10 ³ mbar
Filament temperature	110 °C
Disruption pressure (Burst pressure) (absolute)	10 bar
Measurement volume	10 cm ³
Connection flange	NW16
Filament material	Platinum
Material in contact with the medium	Stainless steel 1.4301, Platinum, chrome nickel 8020, ceramics Al ₂ O ₃ , NiFe 42
Operating temperature	0 to 40 °C
Max. ambient temperature	80 °C

Figure 1 Dimensions

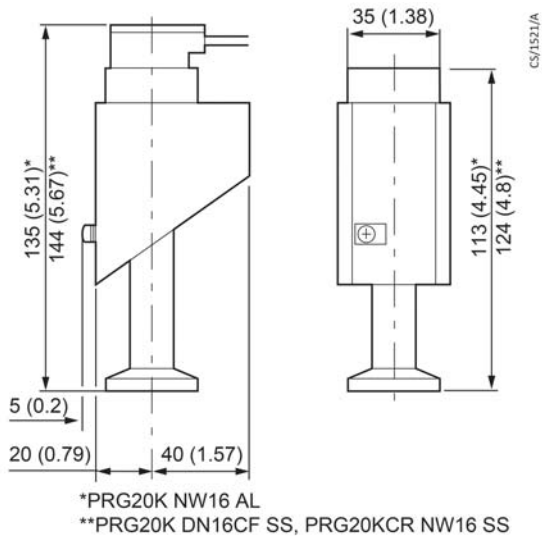

Installation



WARNING:

Do not use the PRG for safety critical applications. The PRG is not intended to be fail safe.



WARNING:

Do not use the PRG to measure the pressure of explosive or flammable gasses or mixtures. The gauge contains a heated filament which can operate at extremely high temperatures under fault conditions.

Supplied equipment

- PRG gauge head
- Securing clip for connector
- Operating instructions

Connection of the gauge head



Note:

Do not install a vent valve in the immediate vicinity of the gauge head. Sudden changes in air flow may result in mechanical damage to the filament.

Install the gauge head vertically, i.e. with the flange facing downwards. Dimensional drawing see [Figure 1](#). The dimensions given with a double asterisk (**) to the PRG20K - DN16CF and PRG20KCR - NW16 gauge head. Otherwise the dimensions are the same for both gauge heads.

The maximum permissible ambient temperature for the gauge head is 80 °C. However, at this temperature the accuracy specified for the gauge head is no longer ensured, as the temperature compensation is only effective up to 40 °C.

If the gauge head is subjected to strong thermal radiation, it has to be protected by a suitable thermal screen. In the case that heat is transferred to the gauge head via the connection cable, a section of the connection cable may be cooled by a cooling spiral.

Any contamination of the sensing cell will impair the accuracy of the pressure readings obtained. Special care must be taken in the presence of substances which cannot be removed by solvents.

Suitable orifice plates or bends may be employed to keep any possible sources of contamination away from the gauge head.

Bent lines should be laid in such a way that no condensate can collect or the vacuum line cannot become blocked.

The gauge heads are connected to the operating unit via standard gauge head cables.

For the purpose of improved resistance to interference the gauge heads have been equipped with an additional ground connection (screw terminal) at the housing which is directly linked to the metal housing of the sensing cell.

Standard gauge head cables are fitted with a ring terminal at each end of the cable. The ring terminals should be connected to the ground connection (screw terminal) at the housing of

the gauge head and the protective earth conductor screw on the rear of the PGC201/PGC202 controller.



Note:

The ground wire may only be connected if potential equalization between the flange of the vacuum apparatus and the operating unit is ensured. If necessary install the gauge head so that it is electrically isolated from the vacuum apparatus.

Ensure that the correct filament material is selected on the PGC201/PGC202 controller. Refer to the operating instructions for the PGC201/PGC202 controller.

Ensure the correct filament material is selected (tungsten or platinum) when operating the gauge head in connection with an operating unit PGC201 and PGC202 (see Operating Instructions PGC201 and PGC202).

The connecting plug can be safely attached to the gauge via the securing clip. To do so, push the clip over the connecting pug and let them snap in the provided holes which are in the shell.

Adjustment of the gauge head

Adjustment is performed as follows:

- Remove the caps covering the potentiometers on the gauge head.
- Vent vacuum system and set 100% potentiometer (Figure 2 item 1) so that the controller indicates full scale (atmospheric pressure).
- Pump down vacuum system to a pressure below 5×10^{-4} mbar and set "0" potentiometer (Figure 2 item 2) so that the controller indicates 0.
- Vent vacuum system and recheck the 100% adjustment. Correct deviation, if any, by means of potentiometer.
- If a correction of the 100% adjustment was necessary the zero adjustment must be repeated in any case.
- After having completed the adjustment fit the caps to cover the potentiometers.

Figure 2 Gauge head PRG20K - NW16 Al / PRG20K - DN16CF SS / PRG20KCR - NW16 SS



Adjustment of the gauge head in connection with operating units PGC201 and PGC202

Refer to the operating instructions supplied with the PGC201 or PGC202.

Maintenance



WARNING:

Contaminated parts can be detrimental to health and environment.

Before beginning work, find out whether any parts are contaminated. Adhere to the relevant regulations and take the necessary precautions when handling contaminated parts.



CAUTION:

Dirt and damage can impair the function of the vacuum component.

When handling vacuum components, take appropriate measures to ensure cleanliness and prevent damage.



CAUTION:

Touching the product with bare hands increases the desorption rate.

Always wear clean, lint-free gloves and use clean tools when working in this area.

Exchanging the sensing cell

All items in this section refer to [Figure 3](#).

One half of the housing (item 1) is fitted with plastic catches (item 2) which must properly engage in the slots (item 8) provided in the other half of the housing (item 7) so as to firmly connect the two halves of the housing (item 1) and (item 7).

Apply a screwdriver to the upper slit on the longer front so as to disengage the plastic catch (item 2) by pushing it backwards. Simultaneously, pull both halves of the shell (item 1) and (item 7) apart.

Next apply a screwdriver to the lower slit on the longer front so as to disengage the plastic catch by pushing it backwards. Simultaneously, pull both halves of the shell apart.

Repeat this for the shorter front.

Detach shell (item 1).

Remove the contact spring (item 4) by loosening the fixing screw (item 3).

Remove the sensing cell (item 11) together with the PCB. and plug (item 6) from the remaining shell.

Carefully separate the sensing cell (item 11) from the PCB (item 6).

Remove the insulating plate (item 5) from the measurement cell.

Exchange the sensing cell.



Note:

The cell can be mounted on the PCB in either orientation.

Insert insulating plate (item 5) between PCB and measurement cell.

During assembly of the gauge head make sure that the holder (item 10) has been placed in the housing shell and that the temperature sensor is pressed against the sensing cell.

The gauge head is reassembled in the reverse order.

Figure 3 Disassembled PRG20K - NW16 Al / PRG20K - DN16CF SS / PRG20KCR - NW16 SS gauge head

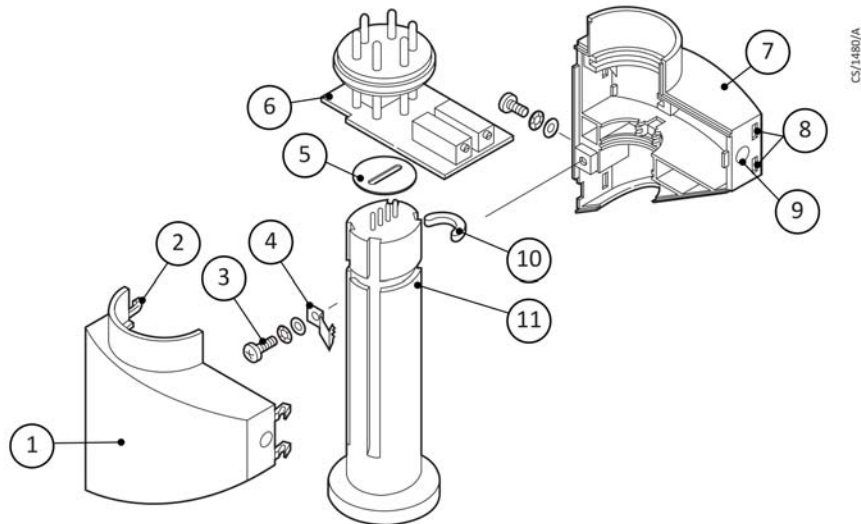

- 1 One half of the housing with plastic catches
- 2 Plastic catch
- 3 Plastic catch
- 4 Contact spring
- 5 Insulating plate
- 6 PCB complete
- 7 One half of the housing with slots
- 8 Slots for opening the housing
- 9 Cap
- 10 Holder
- 11 Sensing cell

Spare parts and accessories

Spares

When ordering spare parts, always indicate:

- All information on the product nameplate.
- Description and ordering number according to the spare parts list.

Product description	Item number
Replacement sensing cell K	D03000209
Replacement sensing cell KCR	D03000229

Accessories

Product description	Item number
PRG Cable 5m	D03000201
PRG Cable 10m	D03000202
PRG Cable 20m	D03000203
PRG Cable 30m	D03000204
PRG Cable 50m	D03000205

Storing and waste disposal

Storage



CAUTION:

Cover the vacuum ports of the product with protective caps or grease free aluminium foil. Do not exceed the admissible storage temperature range.

Inappropriate storage leads to an increase in the desorption rate and/or may result in mechanical damage of the product.

Disposal

Dispose of the PRG and any components safely and in accordance with all local and national safety and environmental requirements.

Alternatively, the PRG and /or cables may be able to be recycled; contact Edwards or supplier for advice (also see below).

The PRG and associated cables are within the scope of the European Directive on Waste and Electronic Equipment, 2012/19/EU. Edwards offers customers a recycling service for the product/cables/associated gauge heads at the end of the product's life. Contact Edwards for advice on how to return the PRG and/or cables for recycling

Returning the product



WARNING:

Products returned to Edwards for service or repair should, if possible, be free of harmful substances (for example, radioactive, toxic, caustic or microbiological). Otherwise, the type of contamination must be declared.

Adhere to the forwarding regulations of all involved countries and forwarding companies and enclose a completed contamination declaration.

Products that are not clearly declared as "free of harmful substances" are decontaminated at the expense of the customer.

Products not accompanied by a duly completed declaration of contamination are returned to the sender at his own expense.

Disposal



WARNING:

Contaminated parts can be detrimental to health and environment.

Before beginning to work, find out whether any parts are contaminated. Adhere to the relevant regulations and take the necessary precautions when handling contaminated parts.



WARNING:

Products returned to Edwards for service or repair should, if possible, be free of harmful substances (for example, radioactive, toxic, caustic or microbiological). Otherwise, the type of contamination must be declared.

Adhere to the forwarding regulations of all involved countries and forwarding companies and enclose a completed contamination declaration.

Separating the components

After disassembling the product, separate its components according to the following criteria:

Contaminated components

Contaminated components (radioactive, toxic, caustic or biological hazard, and so forth) must be decontaminated in accordance with the relevant national regulations, separated according to their materials, and disposed of.

Other components

Such components must be separated according to their materials and recycled.

This page has been intentionally left blank.

This page has been intentionally left blank.

Return the equipment or components for service

Before you send your equipment to us for service or for any other reason, you must send us a completed Declaration of Contamination of Vacuum Equipment and Components - Form HS2. The HS2 form tells us if any substances found in the equipment are hazardous, which is important for the safety of our employees and all other people involved in the service of your equipment. The hazard information also lets us select the correct procedures to service your equipment.

We provide instructions for completing the form in the Declaration of Contamination of Vacuum equipment and Components - Procedure HS1.

If you are returning a vacuum pump, note the following:

- If a pump is configured to suit the application, make a record of the configuration before returning the pump. All replacement pumps will be supplied with default factory settings.
- Do not return a pump with accessories fitted. Remove all accessories and retain them for future use.
- The instruction in the returns procedure to drain all fluids does not apply to the lubricant in pump oil reservoirs.

Download the latest documents from www.edwardsvacuum.com/HSForms/, follow the procedure in HS1, fill in the electronic HS2 form, print it, sign it, and return the signed copy to Edwards.

Note: *If we do not receive a completed HS2 form, we will not accept the return of the equipment.*

