

# Instruction Manual

## *Disposable Liners for the Model 250 Water-Cooled Exhaust Trap*

*Description*

*Item Number*

*Disposable Liners*

*A531-15-020*



# CONTENTS

Section	Title	Page
1	INTRODUCTION	1
1.1	Scope and definitions	1
1.2	Description	1
2	TECHNICAL DATA	1
3	INSTALLATION	2
3.1	Safety	2
3.2	Unpack and inspect	3
3.3	Prepare the exhaust trap	4
3.4	Remove the old liners	6
3.5	Clean the exhaust trap	6
3.6	Install the new liners	9
3.7	Refit the trap	10
3.8	Leak-test the installation	11
4	MAINTENANCE	11
5	STORAGE AND DISPOSAL	11
5.1	Storage	11
5.2	Disposal	11
	RETURN OF BOC EDWARDS EQUIPMENT	

## Illustrations

Figure	Title	Page
1	Exhaust trap connections	5
2	Sectional view of trap and liner components	7
3	Exploded view of liner components	8
4	Alignment of liners (viewed from the top of the trap)	10

## Tables

Table	Title	Page
1	Checklist of components	3

(This page deliberately left blank)

# 1 INTRODUCTION

## 1.1 Scope and definitions

This manual provides installation and maintenance instructions for the Disposable Liners for the BOC Edwards Model 250 Water-Cooled Exhaust Trap. You must use the Disposable Liners as specified in this manual.

Read this manual before you install the Disposable Liners. Important safety information is highlighted as WARNING and CAUTION instructions; you must obey these instructions. The use of WARNINGS and CAUTIONS is defined below.

### WARNING

Warnings are given where failure to observe the instruction could result in injury or death to people.

### CAUTION

Cautions are given where failure to observe the instruction could result in damage to the equipment, associated equipment and process.

## 1.2 Description

The Disposable Liners are designed to fit the Model 250 Water-Cooled Exhaust Trap.

The exhaust trap cools the exhaust gases from the pump and causes particulates to collect on the liners in the trap. This minimises the collection of particulates in the exhaust-system, where they may lead to blockage and so result in downtime of your pumping system. When fully coated, the liners can be easily removed from the trap and be replaced with new liners.

The Water-Cooled Exhaust Trap and the Disposable Liners are particularly suitable for use with a pump which is used for an LPCVD nitride process.

# 2 TECHNICAL DATA

Liner construction materials

Zinc coated mild steel

## 3 INSTALLATION

### 3.1 Safety

#### WARNING

You must use the appropriate procedures to shut down the pumping system before you start to install the Disposable Liners. Ensure that the system has been adequately purged with nitrogen to remove any hazardous substances before you shut down the pumping system.

#### WARNING

The substances accumulated in the exhaust trap are likely to be hazardous. Do not allow your skin or eyes to come into contact with these substances. Do not inhale vapours within the exhaust trap. Wear gloves, goggles and respiratory protective equipment.

#### WARNING

Obey the safety instructions given below and take note of appropriate precautions. If you do not, you can cause injury to people and damage to equipment.

- A suitably trained and supervised technician must install the Disposable Liners.
- Ensure that the installation technician is familiar with the safety procedures which relate to the products used and produced by the process system. Wear the appropriate safety-clothing when you come into contact with contaminated components.
- Vent and purge the process system before you start installation work.
- Ensure that the exhaust trap and the connecting pipelines are at a safe temperature before you start installation.
- You must only use BOC Edwards recommended components to install the Disposable Liners.
- Check that all the required components are available and of the correct type before you start work.
- Disconnect the other components in the process system from the electrical supply so that they cannot be operated accidentally.
- Dispose of the old liners and particulates deposited in the exhaust trap safely.
- Take care to protect sealing-faces from damage.
- Leak-test the vacuum system after installation and seal any leaks found to prevent leakage of dangerous substances out of the system and leakage of air into the system.

### 3.2 Unpack and inspect

Remove all protective covers and check the Disposable Liners.

If the Disposable Liners are damaged, notify your supplier and the carrier in writing within three days; state your order number and invoice number. Retain all packing materials for inspection. Do not use the Disposable Liners if they are damaged.

Check that your package contains the items listed in Table 1. If any item is missing, notify your supplier within three days.

Qty	Description	Check (✓)
1	Inlet liner	<input type="checkbox"/>
2	Outlet liners	<input type="checkbox"/>
1	Cold-finger liner	<input type="checkbox"/>
1	Cold-finger end-cap	<input type="checkbox"/>
1	Outlet end-shield	<input type="checkbox"/>
1	Inlet end-shield	<input type="checkbox"/>
1	Inner liner	<input type="checkbox"/>
2	Top-flange 'O' rings *	<input type="checkbox"/>
1	Inlet insulator	<input type="checkbox"/>
2	Inlet isulator 'O' rings	<input type="checkbox"/>
Outer liner assembly, which consists of:		
10	Liner segments (8 small, 2 large)	<input type="checkbox"/>
2	Retaining rings	<input type="checkbox"/>
1	Inlet gasket	<input type="checkbox"/>
1	Outlet gasket	<input type="checkbox"/>

\* Two sizes of 'O' ring are provided; choose the correct size for your exhaust trap. (Early models of the exhaust trap use the smaller of the two 'O' rings.)

Table 1 - Checklist of components

If the Disposable Liners are not to be used immediately, replace the protective covers. Store the Disposable Liners in suitable conditions as described in Section 5.1.

### 3.3 Prepare the exhaust trap

**WARNING**

Before you open the exhaust trap, ensure that the pressure in the exhaust trap is not above atmospheric pressure.

Refer to Figure 1 and use the following procedure to prepare the exhaust trap.

1. Purge the pumping system, shut down the pump and turn off the cooling-water supply.
2. Allow the exhaust trap and the outlet and inlet elbows (2, 5) to cool to a safe temperature.
3. Undo and remove the clamp (3) which secures the elbow (2) to the trap outlet, then disconnect the elbow from the trap outlet; retain the trapped 'O' ring seal.
4. Place protective caps over the elbow (2) and the trap outlet.
5. Undo and remove the clamp (6) which secures the pump outlet to the trap inlet elbow (5); retain the trapped 'O' ring seal.
6. Place protective caps over the pump outlet and the inlet elbow (5).
7. Place a suitable container under the cooling-water outlet connector (7), then disconnect the cooling-water outlet hose from the trap and allow the cooling-water to drain from the trap.
8. Disconnect the cooling-water inlet hose from the inlet connector (4) on the exhaust trap and move the exhaust trap to a fume-cupboard or a well ventilated area.

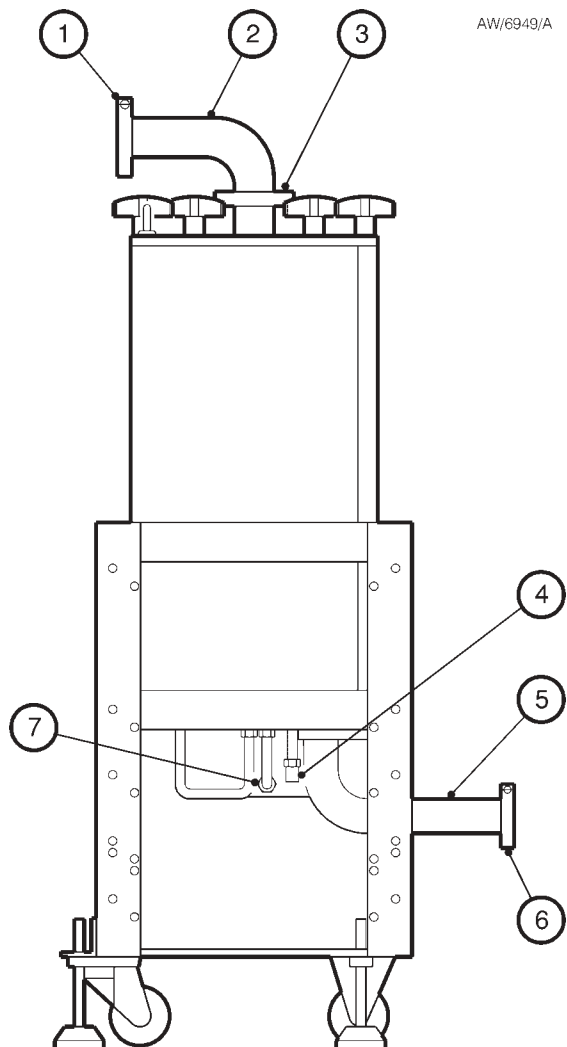

1. Clamp and trapped 'O' ring
2. Outlet elbow
3. Clamp and trapped 'O' ring
4. Cooling-water inlet connector
5. Inlet elbow
6. Clamp and trapped 'O' ring
7. Cooling-water outlet connector

Figure 1 - Exhaust trap connections

### 3.4 Remove the old liners

Refer to Figure 2 in the following procedure. An exploded view of the Disposable liners is shown in Figure 3.

1. Undo and remove the eight thumbwheels (4) which secure the top-flange to the exhaust trap.
2. Remove the top-flange (21) and top-flange 'O' ring (20) from the trap.
3. Remove the outlet liner (2) from the trap outlet (1); note that you can slightly compress the outlet liner to make it easier to remove.
4. Remove the outlet rubber gasket (3) from its position on top of the inner and outer liners.
5. Remove the outlet end-shield (5) from the trap.
6. Remove the inner liner (7) from the trap; note that you can slightly compress the liner to make it easier to remove.
7. Remove the 10 outer liner segments (18) from the trap.
8. Remove the cold-finger end-cap (6) from the trap.
9. Remove the cold-finger liner (17) from the trap; note that you can slightly expand the liner to make it easier to remove.
10. Remove the inlet liner (10) from the trap inlet elbow (11); note that you can slightly compress the liner to make it easier to remove.
11. Undo and remove the eight M6 nuts and washers (12), and remove the inlet insulator (13) and the inlet elbow (11).
12. Remove and dispose of the two 'O' rings (9).
13. Remove the inlet end-shield (16) from the trap; note that the end-shield has lifting-tabs (Figure 3, item 10) to make it easier to remove.
14. Remove the inlet gasket (14) from the trap.
15. Dispose of the top-flange 'O' ring, the inlet and outlet liners, the inlet and outlet end-shields, the inner and outer liners, the cold-finger liner, the cold-finger end-cap and the inlet and outlet gaskets (refer to Section 5).

### 3.5 Clean the exhaust trap

**WARNING**

The substances accumulated in the trap may be dangerous. Do not allow your skin or eyes to come into contact with these substances. Do not inhale vapours from the trap or the connecting pipelines.

1. Use a suitable tool to remove any loose deposits from the body of the trap.
2. Inspect the body of the trap and the inlet flange for damage and corrosion. Do not use the trap if there is excessive damage or corrosion.

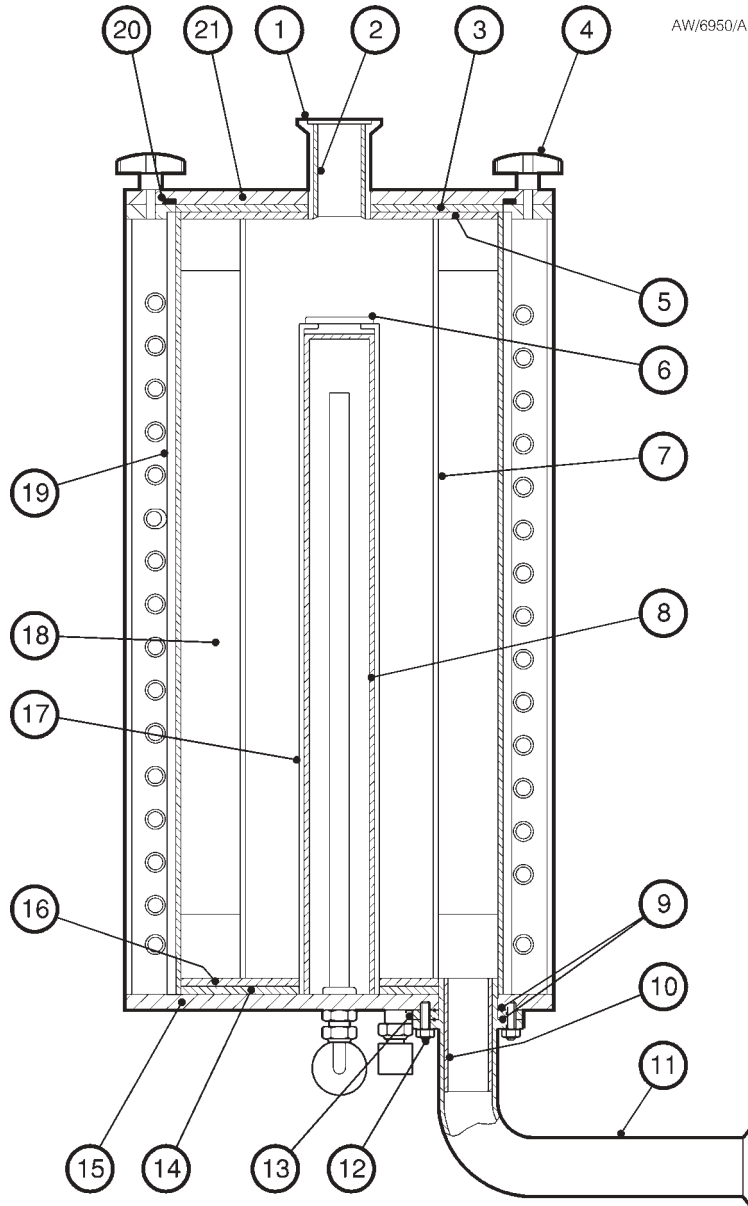

- |                        |                      |                         |
|------------------------|----------------------|-------------------------|
| 1. Trap outlet         | 8. Cold-finger       | 15. Trap base           |
| 2. Outlet liner        | 9. 'O' rings         | 16. Inlet end-shield    |
| 3. Outlet gasket       | 10. Inlet liner      | 17. Cold-finger liner   |
| 4. Thumbwheels (8 off) | 11. Trap inlet elbow | 18. Outer liner segment |
| 5. Outlet end-shield   | 12. Nuts and washers | 19. Trap body           |
| 6. Cold-finger end-cap | 13. Inlet insulator  | 20. 'O' ring            |
| 7. Inner liner         | 14. Inlet gasket     | 21. Trap top-flange     |

Figure 2 - Sectional view of trap and liner components

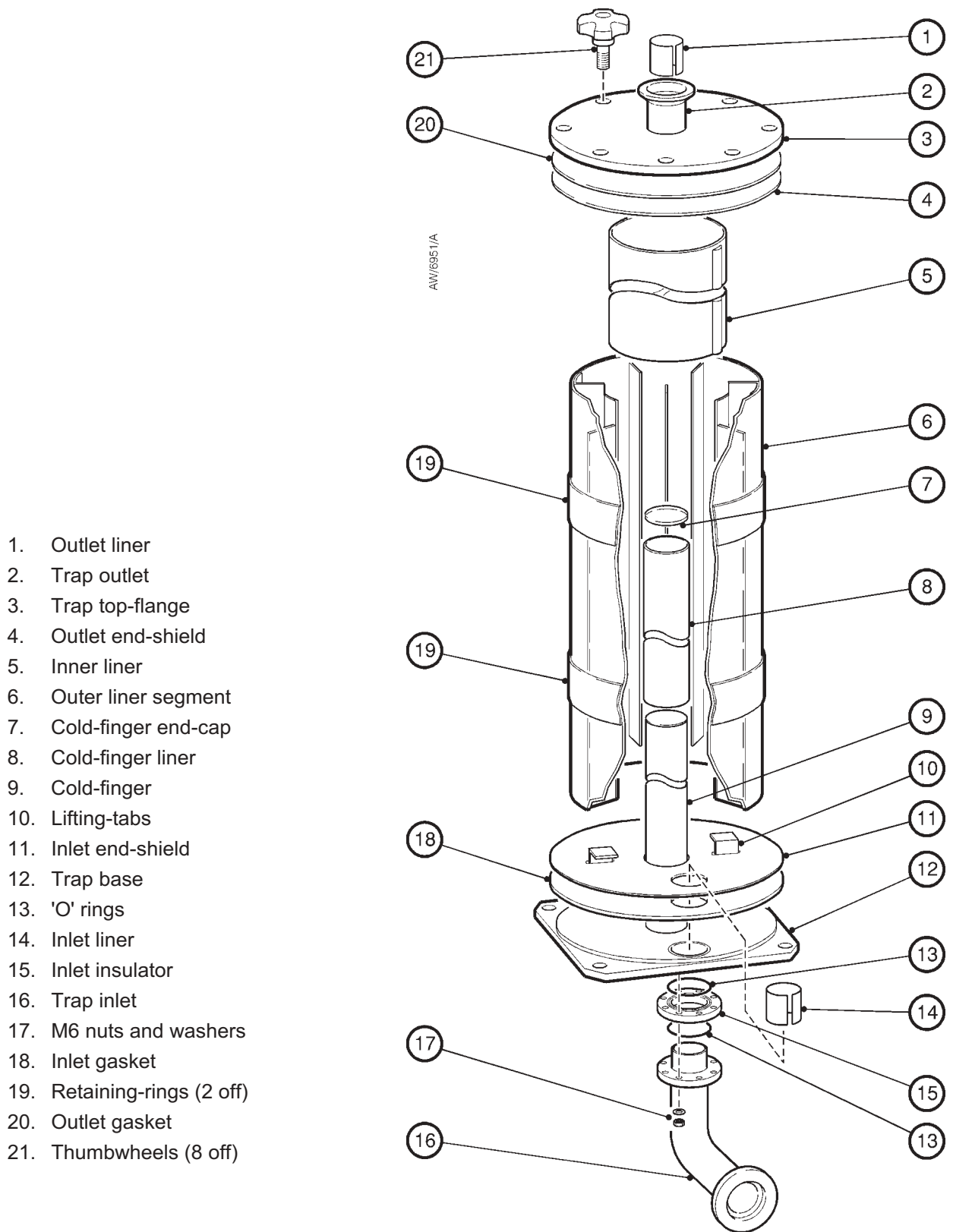

1. Outlet liner
2. Trap outlet
3. Trap top-flange
4. Outlet end-shield
5. Inner liner
6. Outer liner segment
7. Cold-finger end-cap
8. Cold-finger liner
9. Cold-finger
10. Lifting-tabs
11. Inlet end-shield
12. Trap base
13. 'O' rings
14. Inlet liner
15. Inlet insulator
16. Trap inlet
17. M6 nuts and washers
18. Inlet gasket
19. Retaining-rings (2 off)
20. Outlet gasket
21. Thumbwheels (8 off)

Figure 3 - Exploded view of liner components

### 3.6 Install the new liners

#### CAUTION

Ensure that you fit the inner liner (Figure 4, item 2) in the correct orientation. If you do not, the pump exhaust gases will not flow correctly through the liners and the trap will not operate effectively.

Refer to Figure 2 in the following procedure.

1. Fit the inlet elbow (11), the new inlet insulator (13) and the two new 'O' rings (9), then fit and tighten the eight M6 nuts and washers (12): do not over-tighten the nuts, as you may damage the inlet insulator.
2. Fit the new inlet liner (10) into the trap inlet (11); note that you can slightly compress the liner to ease its insertion.
3. Fit the new inlet gasket (14) in the trap body; ensure that the off-centre hole in the gasket aligns with the trap inlet (11).
4. Fit the new inlet end-shield (16) into the trap with the lifting-tabs (Figure 3, item 10) upwards; ensure that the off-centre hole in the end-shield aligns with the trap inlet (11).
5. Fit the new cold-finger liner (17) over the cold-finger (8); note that you can slightly expand the liner to ease its insertion.
6. Fit the new cold-finger end-cap (6) inside the top of the cold-finger liner (17); note that the end-cap is tapered and you must fit the end-cap with the recess in the cap upwards.
7. Align the new outer liner assembly so that the long fin on the inlet segment is adjacent to the trap inlet (see Figure 4), then slide the outer liner assembly into the body of the trap; as you slide the assembly into the trap, allow the retaining rings (Figure 3, item 19) to slide up the outside of the liner segments until they come off. Dispose of the two retaining rings.
8. Fit the new inner liner (7) into the trap so that the gap in the bottom of the liner aligns with the long fin on the outer liner (see Figure 4); note that you can slightly compress the liner to ease its insertion.
9. Fit the new outlet end-shield (5) into the trap.
11. Fit the new outlet gasket (3) into the trap.
11. Remove the dust-cover from the trap outlet and fit the new outlet liner (2) into the trap outlet (1). Two outlet liners are supplied; use the correct size outlet liner for your trap. Note that you can slightly compress the liner to ease its insertion.
12. Place the new top-flange 'O' ring (20) in position. Note that two 'O' rings are supplied; use the correct size 'O' ring for your trap.
13. Refit the top-flange (21) to the trap-body (19); ensure that you do not displace the top-flange 'O' ring. Secure the top-flange to the trap with the eight thumbwheels (4).

### 3.7 Refit the exhaust trap

Refer to Figure 1 in the following procedure.

1. Move the exhaust trap to its operating location.
2. Inspect the trap outlet trapped 'O' ring seal and clamp (3) removed in Section 3.3. If any item is damaged, replace it with a new one.
3. Use the trapped 'O' ring and clamp (3) to connect the elbow (2) to the trap outlet.
4. Use the trapped 'O' ring and clamp (6) to connect the pump outlet to the trap inlet elbow (5).
5. Connect the cooling-water inlet hose to the inlet connector (4) on the trap.
6. Connect the cooling-water outlet hose to the outlet connector (7) on the trap.

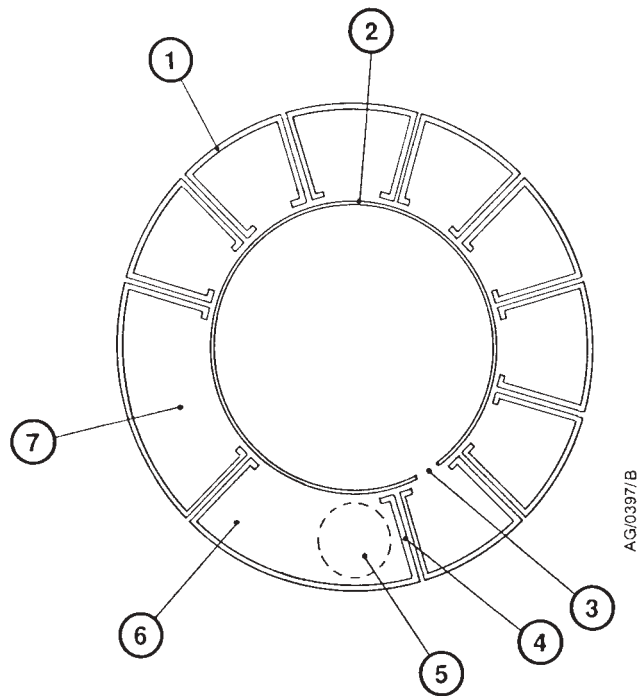

1. Small outer liner segment (8 off)
2. Inner liner
3. Gap at bottom of inner liner
4. Long fin on inlet liner segment
5. Trap inlet position
6. Large (inlet) liner segment
7. Large liner segment

Figure 4 - Alignment of liners (viewed from the top of the trap)

### 3.8 Leak-test the installation

**WARNING**

Leak-test the system after installation and seal any leaks found to prevent the leakage of dangerous substances from the system and leakage of air into the system.

Leak-test the system after you have installed the trap and seal any leaks found. Dangerous substances could otherwise leak from the system. Also, if air leaks into the exhaust-system, this will promote the formation of particulates in the exhaust-system.

We recommend that the total leak rate of the system is  $1 \times 10^{-5}$  mbar l s<sup>-1</sup> ( $1 \times 10^{-3}$  Pa l s<sup>-1</sup>) helium or less.

## 4 MAINTENANCE

You cannot maintain the Disposable Liners. You must remove the liners and refit new liners every six months or sooner.

## 5 STORAGE AND DISPOSAL

### 5.1 Storage

Store the Disposable Liners in cool, dry conditions until required for use. When required, prepare and install the Disposable Liners as described in Section 3.

### 6.2 Disposal

Dispose of the Disposable Liners and any substances removed from the exhaust trap quickly and safely in accordance with all local and national safety and environmental requirements.

Take particular care with components which have been contaminated with dangerous process substances.

(This page deliberately left blank)