



CPG35K AND CP35KB PASSIVE PENNING GAUGE INSTRUCTION MANUAL

Publication number: D0300010001EN

Issue: A

Original Instructions



Declaration of Conformity

We, Edwards,
Innovation Drive,
Burgess Hill,
West Sussex,
RH15 9TW, UK

declare under our sole responsibility, as manufacturer and person within the EU authorised to assemble the technical file, that the product(s)

- Passive Penning (CPG) gauges connected to controllers (PGC).

D03000100	CPG35K - NW40
D03000110	CPG35K - DN40CF
D03000130	CPG35K - NW25
D03000140	CPG35KB - DN40CF
D03000400	PGC201 Pirani/Penning Contr +*

D03000101	CPG cable 5 m
D03000102	CPG cable 10 m
D03000103	CPG cable 20 m
D03000104	CPG cable 30 m
D03000105	CPG cable 50 m

to which this declaration relates is in conformity with the following standard(s) or other normative document(s)

EN61010-1:2010	Safety Requirements for Electrical Equipment for Measurement, Control and Laboratory Use. General Requirements
EN61326-1:2013 Class B, Industrial	Electrical equipment for measurement, control and laboratory Use. EMC requirements. General requirements

and fulfils all the relevant provisions of

(+) 2014/35/EU	Low Voltage Directive
(*) 2014/30/EU	Electromagnetic Compatibility (EMC) Directive
2011/65/EU	Restriction of Certain Hazardous Substances (RoHS) Directive
2012/19/EU	Waste from Electrical and Electronic Equipment (WEEE) Directive

Note: This declaration covers all product serial numbers from the date this Declaration was signed onwards.

Larry Marini, Senior Technical

07.06.2017, Eastbourne

Date and Place

This product has been manufactured under a quality management system certified to ISO 9001:2008

This page intentionally blank.

Copyright notice

© Edwards Limited 2017. All rights reserved.

Trademark credits

Edwards and the Edwards logo are trademarks of Edwards Limited.

Contents

Safety	1
Symbols used	1
Symbols for residual risks	1
Personnel qualifications	1
General safety instructions	1
Responsibility and warranty	2
Description	3
Product Identification	3
Validity	3
Intended use	3
Technical data	4
Installation	5
Supplied equipment	5
Unpacking and inspecting	5
Vacuum connection	5
Electrical connection	5
Maintenance	6
Cleaning of the gauge head	6
Mechanical maintenance	7
Removing and replacing the anode ring and the cathode plate	7
Detaching the permanent magnet	8
Spare parts and accessories	9
Spares	9
Accessories	9
Storage	10
Returning the product	11
Disposal	12
Separating the components	12
Contaminated components	12
Other components	12
Other Disposal Information	12

List of Figures

Dimensions 4
Sectional view of the CPG35K(B) gauge head 7

Safety

Symbols used

Symbols for residual risks



WARNING:

Warnings are given where failure to observe the instruction could result in injury or death to people.



CAUTION:

Cautions are given where failure to observe the instruction could result in damage to the equipment, associated equipment and process.



Note:

Information on correct handling or use. Disregard can lead to malfunctions or minor equipment damage.

Personnel qualifications

All work described in this document may only be carried out by persons who have suitable technical training and the necessary experience or who have been instructed.

General safety instructions

- Adhere to the applicable regulations and take the necessary precautions for the process media used.
- Consider possible reactions with the product materials.
- Adhere to the applicable regulations and take the necessary precautions for all work to be performed and consider the safety instructions in this document.
- Ensure that all vacuum components have not been contaminated before beginning any work. If so, adhere to the relevant regulations and take the necessary precautions when handling contaminated parts.

Communicate the safety instructions to all other users.

Responsibility and warranty

Edwards will not assume any responsibility or warranty in cases where the operator or third persons:

- Do not observe the information given in this document.
- Do not use the product as intended.
- Modify the product in any way (conversions, repair work etc).
- Operate the product with accessories not listed in the corresponding product documentation.

Subject to technical alterations without prior notice. The figures are not binding.

Description

The CPG is a Penning gauge head. Operation of the gauge head is based on the principle of cold cathode ionisation.

Product Identification

In all communication with Edwards, please specify the information on the product nameplate.

Validity

This document applies to the following part numbers:

Product Description	Item number
CPG35K NW40 Passive Penning Gauge	D03000100
CPG35K DN40CF Passive Penning Gauge	D03000110
CPG35K NW25 Passive Penning Gauge	D03000130
CPG35KB DN40CF Passive Penning Gauge Bakeable	D03000140

Intended use

The CPG may only be used for the measurements of total pressures in vacuum systems and only when converted to a PGC201 vacuum gauge controller instrument.

Technical data

Measurement principle	Gas discharge
Measurement range	1×10^{-9} to 1×10^{-2} mbar
Material in contact with the medium	Cr, Mo, Nb, Ti, Ni, NiFe, NiCr, glass and ceramics
Disruption pressure (burst pressure) (absolute)	10 bar
Ambient temperature	
CPG35K	80 °C
CPG35KB	200 °C
Measurement volume	
CPG35K - NW25 and NW40	approximately 18 cm ³
CPG35K and KB - DN40CF	approximately 21 cm ³
Connection flange	
CPG35K	NW25
CPG35K	NW40
CPG35K	DN40CF
CPG35KB	DN40CF
Weight	
CPG35K - NW25 and NW40	approximately 0.30 kg
CPG35K and KB - DN40CF	approximately 0.60 kg

Figure 1 Dimensions

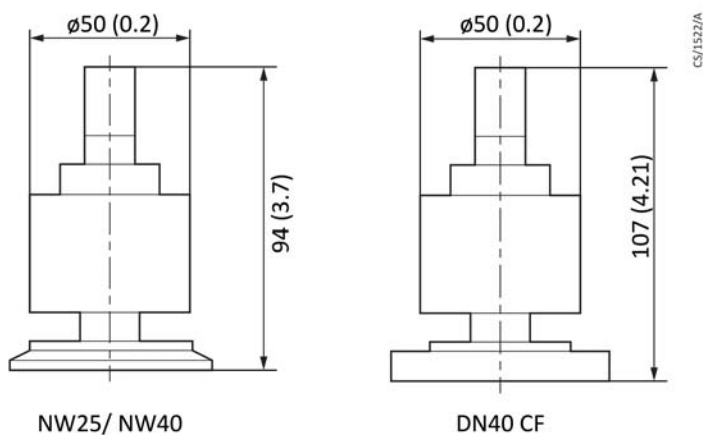

Installation



WARNING:

Do not use the CPG for safety critical applications. The CPG is not intended to be fail safe.



WARNING:

Do not use the CPG to measure the pressure of explosive or flammable gasses or mixtures.

Supplied equipment

- CPG gauge head
- Operating instructions

The gauges outlined in this manual are for use with the Edwards PGC201 controller.

Unpacking and inspecting

Remove all packing materials and protective covers and check the CPG35K(B) gauge. If the CPG35K(B) gauge is damaged, notify your supplier and carrier in writing within three days; state the Item Number of the CPG35K(B) gauge together with the order number and supplier's invoice numbers. Retain all packaging materials for inspection. Do not use the CPG35K(B) gauge if it is damaged.

Vacuum connection

The gauge head is connected via a NW25/NW40 flange and a centring-ring to the vacuum system. In the case of DN 40 CF flanges a copper gasket must be inserted between the flanges.

All gauges should be located as close as possible to the point where the pressure is to be measured with the exception of cases where there is potential for considerable contamination of the gauge head. In these cases, the gauge head should be mounted a short distance away (behind an elbow).

In the case of long and narrow connections, the measured pressure will be too low, mainly because of gas consumption by the gauge head. The gauge head may be mounted in any position, but preferably not at the lowest point in the vacuum system.

Electrical connection



CAUTION:

When connecting the gauge head cable special care must be taken to plug the cable end equipped with the socket contact onto the pins of the gauge head connector.

The knurled screw on the plug is used to lock the connection.

Maintenance



WARNING:

Contaminated parts can be detrimental to health and environment.

Before beginning work, find out whether any parts are contaminated. Adhere to the relevant regulations and take the necessary precautions when handling contaminated parts.



CAUTION:

Dirt and damage can impair the function of the vacuum component.

When handling vacuum components, take appropriate measures to ensure cleanliness and prevent damage.



CAUTION:

Touching the product with bare hands increases the desorption rate.

Always wear clean, lint-free gloves and use clean tools when working in this area.

Cleaning of the gauge head

To clean the gauge, pull out anode ring (Figure 2 item 5), ceramic disc (Figure 2 item 6) and cathode plate (Figure 2 item 4) inside the housing (see [Mechanical maintenance](#)). If required, clean the anode ring with abrasive emery cloth. Do not attempt to clean the cathode plates. Dirty cathode plates must be exchanged.

In order to provide protection against soiling of the bushing, the gauge heads are supplied with a ceramic disk between the anode ring and the bushing.

The position of the disk is shown in [Figure 2](#).

Each time the anode ring or cathode plate is exchanged, the ceramic disc must also be exchanged.

No cleaning is required when exchanging the cathode plate and anode ring. Refer to [Mechanical maintenance](#).

After removing the emery paper residues and reassembly of the components, any fingerprints and other residues have to be removed by rinsing the gauge head with a solvent, followed by a drying period.

For thorough cleaning of the gauge head cell, it is recommended to dismantle the permanent magnets. Only then it is possible to flush out any iron filings from the measuring chamber that have been attracted by the magnets.

**Note:**

Do not allow the ceramic bushing to get wet as it is able to absorb water.

The leakage current which results then causes the pressure to be shown on the operating device as higher than it actually is.

Figure 2 Sectional view of the CPG35K(B) gauge head

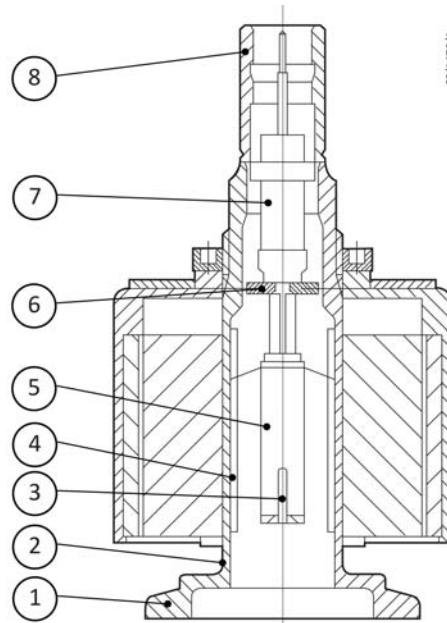

- 1 Small flange NW25, NW40, DN40 CF
- 2 Gauge head body
- 3 Anode pin
- 4 Cathode plate
- 5 Anode ring with ignition pin
- 6 Ceramic disc
- 7 Current leadthrough
- 8 Connection socket

Mechanical maintenance

Removing and replacing the anode ring and the cathode plate

1. With a pair of flat nose pliers it is possible to remove the anode ring and the cathode plate (Figure 2 item 4) fixed elastically in the measurement chamber from the measurement chamber.
2. Replace or clean the removed parts (see [Cleaning of the gauge head](#)).
3. After having inserted the anode ring it should be strictly observed that the two open sides of the anode ring are equally distant from the cathode plate and that the ignition pins don't touch the chamber (distance approximately 1 mm).

Detaching the permanent magnet

1. Detach the gauge head cable.
2. Unscrew and remove the nut on the protection cap.
3. Remove the protection cap and the magnet.
4. Clean as described in [Cleaning of the gauge head](#).
5. Reassemble in the reverse order.

Spare parts and accessories

Spares

When ordering spare parts, always indicate:

- All information on the product nameplate.
- Description and ordering number according to the spare parts list.

Description	Item number
Spare cathode plates and discs	D03000109
Spare Anode Ring	D03000119

Accessories

Description	Item number
CPG Cable 5 m	D03000101
CPG Cable 10 m	D03000102
CPG Cable 20 m	D03000103
CPG Cable 30 m	D03000104
CPG Cable 50 m	D03000105

Storage



CAUTION:

Inappropriate storage leads to an increase of the desorption rate and/or may result in mechanical damage of the product.

Cover the vacuum ports of the product with protective lids or grease free aluminum foil. Do not exceed the admissible storage temperature range.

Returning the product



WARNING:

Products returned to Edwards for service or repair should, if possible, be free of harmful substances (for example, radioactive, toxic, caustic or microbiological). Otherwise, the type of contamination must be declared.

Adhere to the forwarding regulations of all involved countries and forwarding companies and enclose a completed contamination declaration.

Products that are not clearly declared as "free of harmful substances" are decontaminated at the expense of the customer.

Products not accompanied by a duly completed declaration of contamination are returned to the sender at his own expense.

Disposal



WARNING:

Contaminated parts can be detrimental to health and environment.

Before beginning to work, find out whether any parts are contaminated. Adhere to the relevant regulations and take the necessary precautions when handling contaminated parts.



WARNING:

Products returned to Edwards for service or repair should, if possible, be free of harmful substances (for example, radioactive, toxic, caustic or microbiological). Otherwise, the type of contamination must be declared.

Adhere to the forwarding regulations of all involved countries and forwarding companies and enclose a completed contamination declaration.

Separating the components

After disassembling the product, separate components according to the following criteria:

Contaminated components

Contaminated components (radioactive, toxic, caustic or biological hazard, and so forth) must be decontaminated in accordance with all local and national regulations, separated according to their materials, and disposed of.

Other components

Such components must be separated by material make-up and then recycled.

Other Disposal Information

The CPG35K(B) and associated cables are within the scope of the European Directive on Waste and Electronic Equipment, 2012/19/EU. Edwards offers customers a recycling service for the product/cables/associated gauge heads at the end of the product's life. Contact Edwards for advice on how to return the CPG and/or cables for recycling.

Return the equipment or components for service

Before you send your equipment to us for service or for any other reason, you must send us a completed Declaration of Contamination of Vacuum Equipment and Components - Form HS2. The HS2 form tells us if any substances found in the equipment are hazardous, which is important for the safety of our employees and all other people involved in the service of your equipment. The hazard information also lets us select the correct procedures to service your equipment.

We provide instructions for completing the form in the Declaration of Contamination of Vacuum equipment and Components - Procedure HS1.

If you are returning a vacuum pump, note the following:

- If a pump is configured to suit the application, make a record of the configuration before returning the pump. All replacement pumps will be supplied with default factory settings.
- Do not return a pump with accessories fitted. Remove all accessories and retain them for future use.
- The instruction in the returns procedure to drain all fluids does not apply to the lubricant in pump oil reservoirs.

Download the latest documents from www.edwardsvacuum.com/HSForms/, follow the procedure in HS1, fill in the electronic HS2 form, print it, sign it, and return the signed copy to Edwards.

Note: *If we do not receive a completed HS2 form, we will not accept the return of the equipment.*

