

Instruction Manual

212-J/412-J Microvac[®] Pumps



212-J

412-J



Description	Item Number
212J Microvac Rotary Piston Pump 230/460 V, 3 Ø, 60 Hz with 230/460 V Coil	900-212-014
212J Microvac Rotary Piston Pump 400 V, 3 Ø, 60 Hz with 380 V Coil	900212014501
212J Microvac Rotary Piston Pump 400 V, 3 Ø, 60 Hz with 415 V Coil	900212014502
212J Microvac Rotary Piston Pump 400 V, 3 Ø, 60 Hz with 380 V Coil with Water Miser	900212014503
212J Microvac Rotary Piston Pump 400 V, 3 Ø, 60 Hz with 415 V Coil with Water Miser	900212014504
412J Microvac Rotary Piston Pump 230/460 V, 3 Ø, 60 Hz with 230/460 V Coil	900-412-014
412J Microvac Rotary Piston Pump 400 V, 3 Ø, 50 Hz with 380 V Coil	900412014501
412J Microvac Rotary Piston Pump 400 V, 3 Ø, 50 Hz with 415 V Coil	900412014502
412J Microvac Rotary Piston Pump 400 V, 3 Ø, 50 Hz with 380 V Coil with Water Miser	900412014503
412J Microvac Rotary Piston Pump 400V, 3 Ø, 50 Hz with 415 V Coil with Water Miser	900412014504





Declaration of Conformity

We, Edwards,
Crawley Business Quarter,
Manor Royal,
Crawley,
West Sussex, RH10 9LW, UK

declare under our sole responsibility, as manufacturer and person within the EU authorised to assemble the technical file, that the product(s)

900 YYYYYY 50 Z

↓	→
Pump Model	Voltage/TCV Option
YYYYYY	Z
212014 = 212-J Pump	1 = 400 V, 3 Ph, 50 Hz/380 V, 3 Ph, 50 Hz
412014 = 412-J Pump	2 = 400 V, 3 Ph, 50 Hz/415 V, 3 Ph, 50 Hz
	3 = 400 V, 3 Ph, 50 Hz/380 V, 3 Ph, 50 Hz with TCV
	4 = 400 V, 3 Ph, 50 Hz/415 V, 3 Ph, 50 Hz with TCV

to which this declaration relates is in conformity with the following standard(s) or other normative document(s)

EN1012-2:1996, A1: 2009	Compressors and Vacuum Pumps. Safety Requirements. Vacuum Pumps
EN60034-1: 2004	Rotating electrical machines. Rating and performance
EN50581:2012	Technical Documentation for the Assessment of Electrical and Electronic Products with respect to the Restriction of Hazardous Substances

and fulfils all the relevant provisions of

2006/42/EC	Machinery Directive
2006/95/EC	Low Voltage Directive
2004/108/EC	Electromagnetic Compatibility (EMC) Directive
2011/65/EU*	Restriction of Certain Hazardous Substances (RoHS) Directive

* i.e. The product(s) contain less than - 0.1wt% for hexavalent chromium, lead, mercury, PBB and PBDE; 0.01wt% for cadmium - in homogeneous materials (subject to the exemptions allowed by the Directive). The RoHS Directive does not legally apply to industrial vacuum equipment until July 2019 (July 2017 for instruments).

Note: This declaration covers all product serial numbers from the date this Declaration was signed onwards.

Peter Meares, GV Technical Support Manager

13.03.2013, Burgess Hill

Date and Place

This product has been manufactured under a quality system registered to ISO9001

Contents

Section	Page
1	Introduction 1
1.1	Scope 1
1.2	ATEX directive implications 2
1.3	Description 2
1.3.1	Gas ballast 2
1.3.2	Water system 2
1.3.3	Electrical system 5
1.3.4	Lubricants 5
1.3.5	Guards 5
1.3.6	Vacuum access ports 5
1.3.7	Oil temperature sensor/heater access ports (412-J pump only) 5
1.3.8	Oil drain port (412-J pump only) 5
2	Technical data 7
2.1	Operating and storage conditions 7
2.2	Pump specifications 7
2.3	Materials in contact with process gases 8
2.4	Electrical data 8
3	Installation 11
3.1	Safety 11
3.2	System design considerations 12
3.3	Unpack and inspect 12
3.4	Locate the pump 12
3.5	Inlet piping 13
3.5.1	Vacuum access port locations 14
3.6	Exhaust piping 15
3.7	Electrical connections 16
3.8	Cooling 18
3.9	Pump lubrication 18
3.9.1	Initial oil fill 19
4	Operation 21
4.1	Pre-start check 21
4.2	Pump start 21
4.3	Gas ballast operation 22
4.4	Pump stop 23
4.5	Operating notes 23
5	Maintenance 25
5.1	Safety information 25
5.2	Leak detection 25
5.3	Maintenance plan 26
5.4	Oil change 27
5.5	Oil level check 27
5.6	Valve deck maintenance 27
5.7	Belt maintenance 28
5.8	Drive belt tension 28
5.9	Gas ballast check valve replacement 28
5.10	Fitment or replacement of the motor (412J models only) 29

5.11	Fault finding	30
6	Storage and disposal	33
6.1	Storage	33
6.2	Disposal	33
7	Spares and accessories	35
7.1	Introduction	35
7.2	Service	35
7.3	Spares	35
7.4	Accessories	35
8	PFPE-prepared Microvac pumps	37
8.1	Summary	37
8.2	Installation	37
8.3	Operation	37
8.4	Maintenance	37

For return of equipment, complete the HS Forms at the end of this manual.

Illustrations

Figure		Page
1	Theory of operation	2
2	212-J pump general arrangement	3
3	412-J pump general arrangement	4
4	212-J pump dimensions	9
5	412-J pump dimensions	10
6	Inlet piping configurations	14
7	Exhaust piping	16
8	Electrical schematic	17
9	Gas ballast setting	22
10	Typical vacuum system piping	26
11	Collar bolt positions and motor frame sizes	29

Tables

Table	Page
1 General data	7
2 Pump technical specifications	7
3 Motor specifications, IEC motors (CE pumps)	9
4 Motor specifications, NEMA motors	10
5 Maintenance plan	26
6 Belt tension	28
7 Motors the can be fitted to 412J pump models	29
8 Fault finding guide	30
9 Accessories	35

Associated publications

Publication title	Publication number
Vacuum pump and vacuum system safety	P300-20-000

Trademark credits

Fomblin® is a registered trademark of Ausimont SpA.

This page has been intentionally left blank.

1 Introduction

1.1 Scope

This manual provides installation, operation and maintenance instructions for Model 212-J and 412-J Microvac pumps (referenced as 'Microvac pump' throughout the remainder of the manual). The Microvac pump must be used as specified in this manual. Read this manual before installing and operating the pump.

Important safety information is highlighted as WARNING and/or CAUTION instructions which must be followed. The use of WARNINGS and/or CAUTIONS is defined below.



WARNING

Warnings are given where failure to observe the instruction could result in injury or death to people.

CAUTION

Cautions are given where failure to observe the instruction could result in damage to the equipment, associated equipment and process.

The units used throughout this manual conform to SI international system of measurement followed by imperial units in parenthesis; SI (imperial).

The following warning symbols are on the pump:



Warning - refer to accompanying documentation.



Warning - risk of electric shock.



Warning - hot surfaces.



Warning - risk of explosion



Warning - use protective equipment



Warning - moving parts

1.2 ATEX directive implications

The Microvac pump is not designed to meet European ATEX requirements.

1.3 Description

The Microvac pumps are self-contained, rotary, oil sealed piston type units. An eccentric mounted on the drive shaft drives the piston. Two free-oscillating floating hinge bars in the pump housing guide the piston slide. The piston assembly rotates clockwise when facing the drive end. Air enters the pump through the intake and passes through the piston slide as the piston performs its intake stroke. As the piston nears the top center position the intake port is closed, separating the system from the pump (see Figure 1). The air is entrapped on the front side of the piston as it begins the next stroke. As the piston continues to rotate, the entrapped air is compressed and discharged through the exhaust valves and out the reservoir exhaust outlet. The exhaust valves are a corrosion-resistant, heavy duty, poppet type.

Figure 1 - Theory of operation

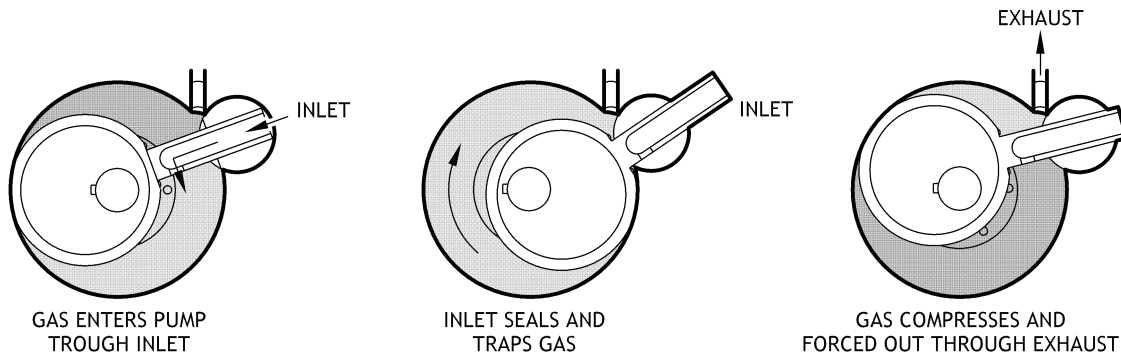

When the pump is in operation, lubrication of the internal parts is completely automatic. Oil is forced by atmospheric pressure from the reservoir through internal oil passages to the shaft bearings. The oil is then fed into the pump to provide the necessary piston-to-cylinder oil seal. The oil in the pumping chamber is forced out through the exhaust valves with the compressed air and returns to the reservoir. A solenoid valve prevents oil from flooding the pump in the event of a power failure or when the pump is shutdown without vacuum being broken.

The pump general arrangements are provided in Figures 2 and 3.

1.3.1 Gas ballast

To pump high vapour loads, gas ballast is delivered into the pump to prevent condensation of the vapour carried by the pump gases.

Air can be introduced to the low vacuum stage. Alternatively, an inert gas such as nitrogen can be supplied through a suitable external valve.

1.3.2 Water system



WARNING

Cooling lines must be installed as to not create a trip hazard which can result in injury to personnel.

A cooling water supply rated at 30 °C (85 °F) and 5.7 LPM (1.5 GPM) for the 212-J, and 7.6 LPM (2 GPM) for the 412-J maximum is required for efficient pump performance. Internal pump water pressure should not exceed 35 psig (Refer to Section 3.8 for information).

Figure 2 - 212-J pump general arrangement

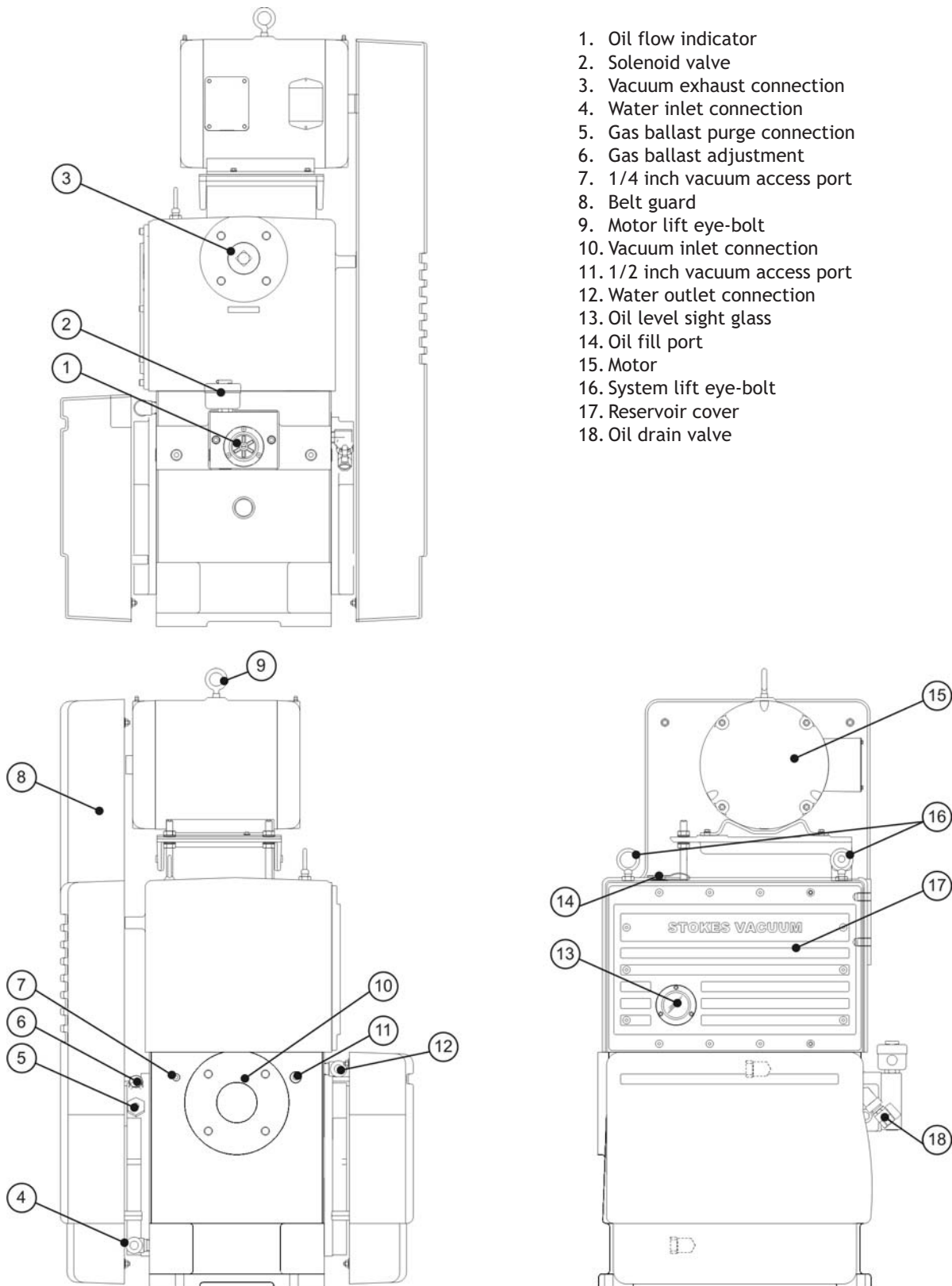

1. Oil flow indicator
2. Solenoid valve
3. Vacuum exhaust connection
4. Water inlet connection
5. Gas ballast purge connection
6. Gas ballast adjustment
7. 1/4 inch vacuum access port
8. Belt guard
9. Motor lift eye-bolt
10. Vacuum inlet connection
11. 1/2 inch vacuum access port
12. Water outlet connection
13. Oil level sight glass
14. Oil fill port
15. Motor
16. System lift eye-bolt
17. Reservoir cover
18. Oil drain valve

Figure 3 - 412-J pump general arrangement

- 1. Oil level sight glass
- 2. System lift eye-bolt
- 3. Motor lift eye-bolt
- 4. Reservoir cover
- 5. Oil flow indicator
- 6. 1/2 inch vacuum access port
- 7. Oil drain port, dead end
- 8. Vacuum exhaust connection
- 9. Motor
- 10. Oil fill port/pressure relief
- 11. Water outlet connection
- 12. Solenoid valve
- 13. Oil temperature sensor port
- 14. Oil temperature heater port
- 15. Oil drain valve
- 16. Water inlet connection
- 17. Gas ballast purge connection
- 18. Gas ballast adjustment
- 19. 1/4 inch vacuum access port
- 20. Belt guard
- 21. Vacuum inlet connection

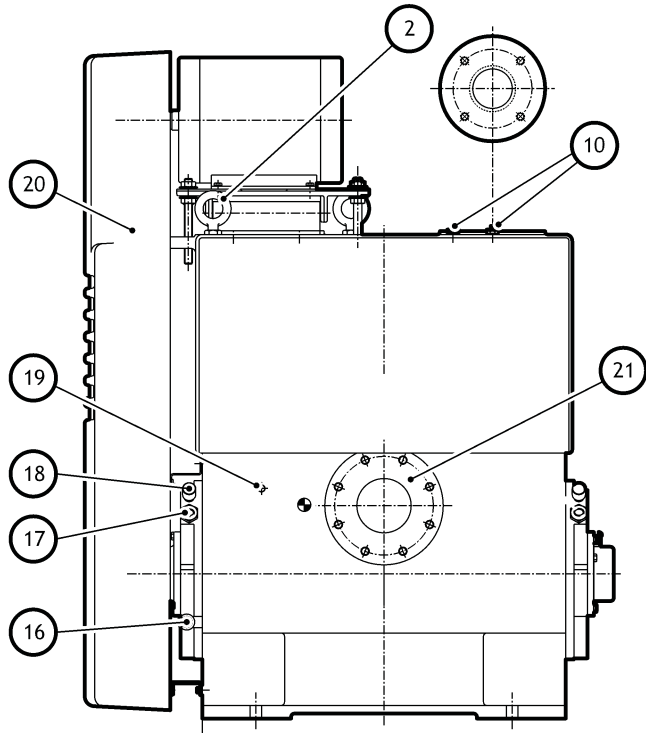
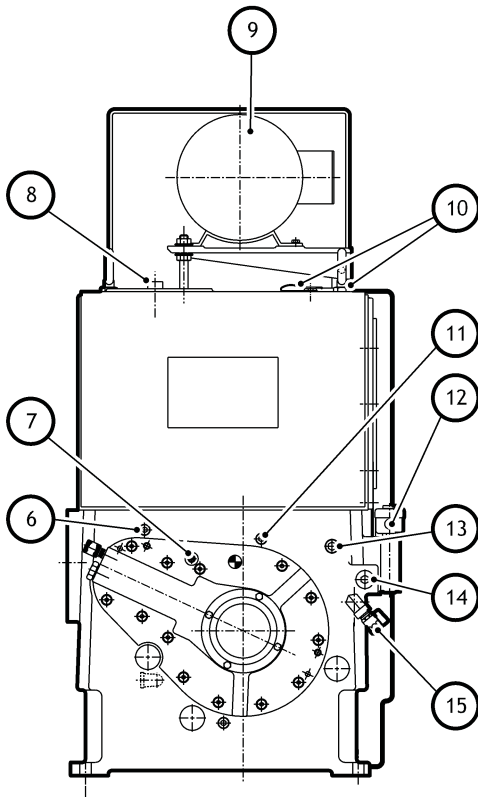
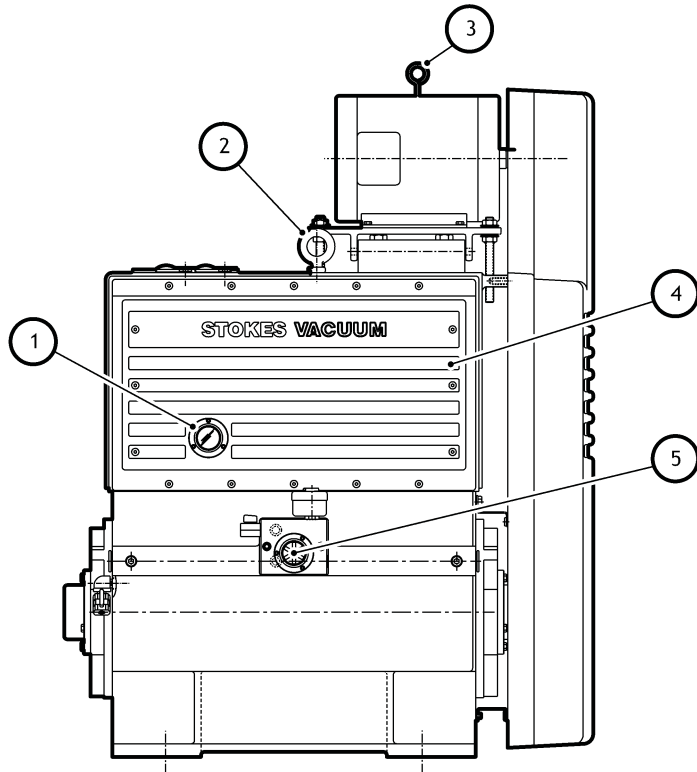

dcS/8822/009

1.3.3 Electrical system



WARNING

Electrical lines must be installed as to not create a trip hazard which can result in injury to personnel.

The main power supply is 400 VAC/3 Ph/ 50 Hz and should be wired through a suitable fused motor starter. Power for the oil solenoid is taken from any two motor leads. Check both motor and solenoid nameplates to insure proper voltage (Refer to Section 3.7 for information).

1.3.4 Lubricants

Refer to Section 2 for recommended pump fluids.

1.3.5 Guards

The motor pulley, pump pulley, belts and flywheel are enclosed by guards to prevent accidental contact with these parts. The pump should never be operated with guards removed.

1.3.6 Vacuum access ports

CAUTION

When connecting a gauge to one of the ports, it is necessary to provide a 90° elbow and a minimum of 305 mm (12 inches) of vertical pipe to the gauge sensor to reduce the chance of contaminating the gauge with pump lubricants.

The pump is provided with 1/4 inch and 1/2 inch NPT vacuum access ports. These ports are provided for customer convenience. The ports can be used for gauges to monitor the pump performance or access for introducing purge gases to the pump.

1.3.7 Oil temperature sensor/heater access ports (412-J pump only)

Oil temperature sensor/heater ports have been added to the 412-J pump to provide a means to monitor and heat the pump oil. The sensor monitors the oil temperature in the pump and can be used as an indicator for service. The heater can be used to heat the oil if it is below minimum starting temperature to reduce the amount of condensables in the oil (Refer to Figure 3 Items 13 and 14).

1.3.8 Oil drain port (412-J pump only)

A 1/4 inch oil drain access port has been added to provide a means of removing oil that pools above the valve decks (Refer to Figure 3 Item 7).

This page has been intentionally left blank.

2 Technical data

2.1 Operating and storage conditions

Table 1 - General data

General items	Reference data
Ambient temperature range (operation)	12 to 40 °C (54 to 104 °F)
Normal surface temperature of the pump body at ultimate vacuum (operation), ambient temperature of 20 °C (68 °F)	50 to 70 °C (122 to 158 °F)
Maximum humidity (operation)	90 % RH
Ambient temperature range (storage)	-30 to 70 °C (-22 to 158 °F)

2.2 Pump specifications

Technical specifications for Microvac pumps are provided in Table 2. Pump dimensions are shown in Figures 4 and 5.

Table 2 - Pump technical specifications

Specification	Unit	212-J	412-J
Ultimate vacuum	microns Hg	< 25	< 25
Displacement	cfm	150	300
	m ³ h ⁻¹	255	510
Pump speed	rpm	500	490
Vacuum inlet	inch	3 ANSI	4 ANSI
Vacuum exhaust	inch	2 NPT/FLG	3 NPT/FLG
Noise level at 1 metre*	dB(A)	< 77	< 83
Vibration severity [†]	mm/sec	7	7
Pipe connections			
Water inlet	inch	1/2 NPT	1/2 NPT
	mm	13	13
Water outlet	inch	1/2 NPT	1/2 NPT
	mm	13	13
Oil capacity	gal	4	12
	litres	15	46
Weight			
Net	lb	950	1875
	kg	431	850
Shipping	lb	1075	1975
	kg	488	896
Height	inch	46	55
	mm	1171	1395
Floor space	inch	26-1/4 x 24	40-1/4 x 25-5/8
	mm	667 x 610	1022 x 651

Table 2 - Pump technical specifications (continued)

Specification	Unit	212-J	412-J
Cooling water consumption (maximum)	gpm	1.5	2
	lpm	5.7	7.6
Inlet cooling water temperature (maximum)	°F	85	85
	°C	30	30

* The noise level was measured in accordance with ISO2151 and with the pump running at ultimate pressure. Running at higher inlet pressures will increase the noise level.

† Measured at the inlet port to ISO2372 (1974).

2.3 Materials in contact with process gases

The following material will come in contact with process gases. A safety review should be performed considering the effect of process gases on the following materials: Aluminum; Buna N; Brass; Cast Iron; Ductile Iron; Fluoroelastomer; Steel; Stainless Steel; Hydrocarbon Oil, and; Atmosphere.

2.4 Electrical data

The motor specifications are provided in Table 3 and Table 4.

Items ending with 501 or 503 utilize a 380 VAC, 50 Hz solenoid. Items ending with 502 or 504 utilize a 415 VAC, 50 Hz solenoid.

Figure 4 - 212-J pump dimensions

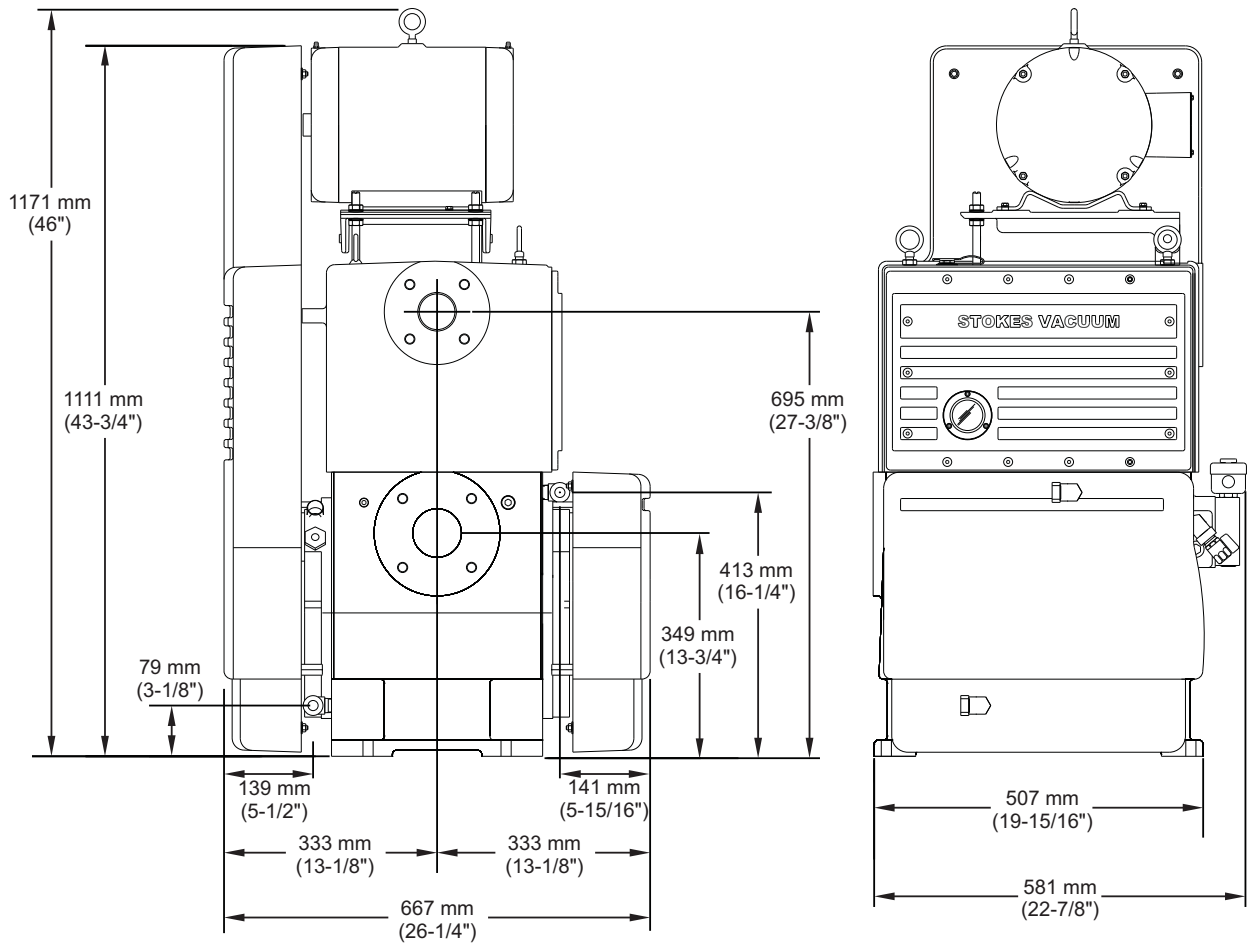
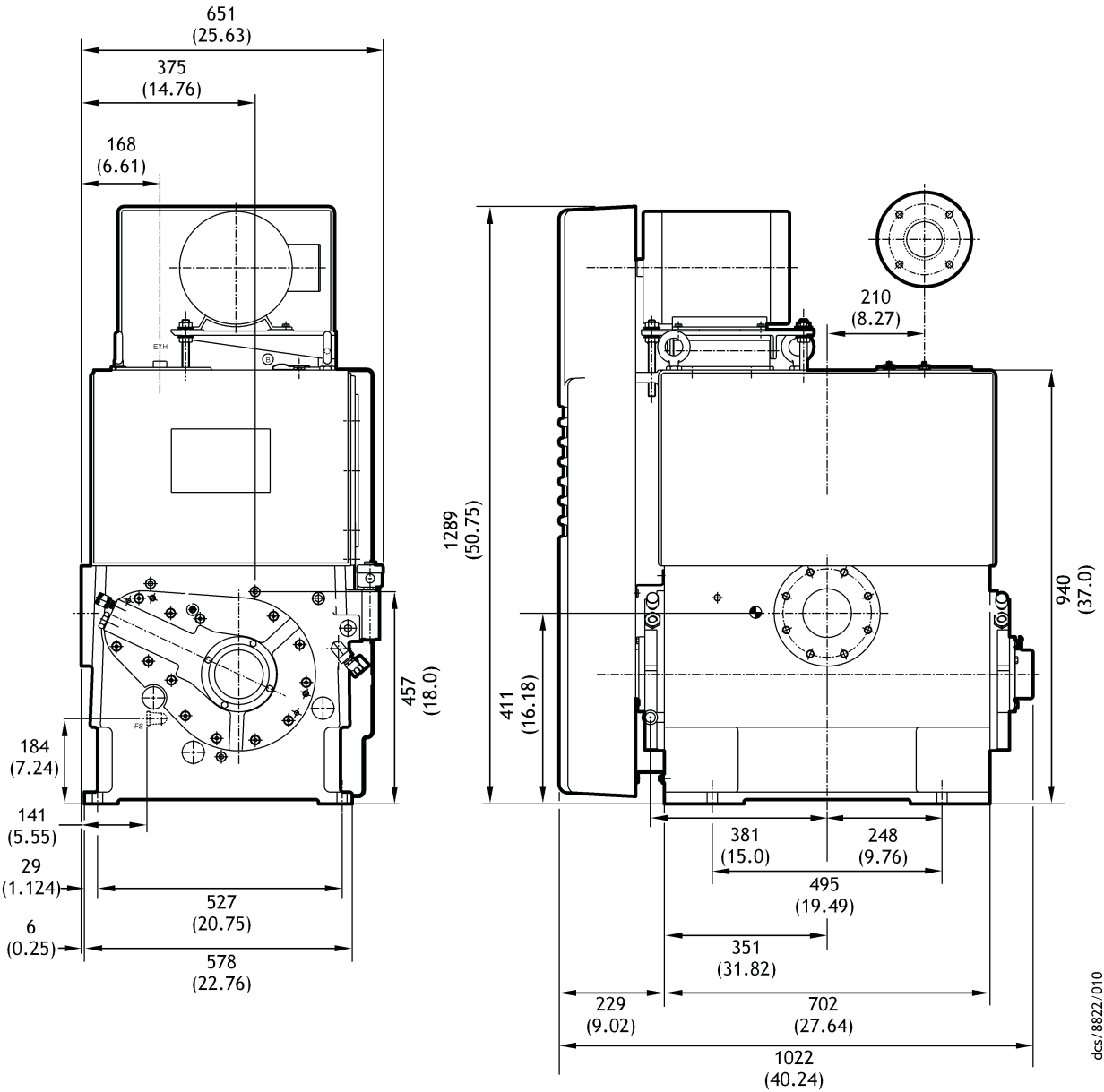

Table 3 - Motor specifications, IEC motors (CE pumps)

Specification	900212014501/2/3/4	900412014501/2/3/4
Enclosure	IP55	IP55
Ambient temperature	40 °C (104 °F)	40 °C (104 °F)
Frame	132	160
Insulation class	F	F
Electrical supply	200/400	200/400
Mounting	B3	B3
Phase/frequency	3/50 Hz	3/50 Hz
kW	5.5	11.0

Note: Refer to motor rating nameplate for weight, efficiency, motor speed, and full load amperage values.

Figure 5 - 412-J pump dimensions



dcs/8822/010

Table 4 - Motor specifications, NEMA motors

Specification	900-212-014	900-412-014
Enclosure	TEFC	TEFC
Ambient temperature	40 °C (104 °F)	40 °C (104 °F)
Frame	213T	215T
Insulation class	F	F
Electrical supply	230/460	230/460
Mounting	B3	B3
Phase/frequency	3/60 Hz	3/60 Hz
HP	7.5	10.0

Note: Refer to motor rating nameplate for weight, efficiency, motor speed, and full load amperage values.

3 Installation

3.1 Safety



WARNING

If you use a hydrocarbon oil in this pump, you must not use the pump to process oxygen in concentrations greater than 25% in volume. If you do, there is a risk of fire or explosion in the oilbox of the pump.



WARNING

We do not recommend that you use the Microvac pumps to pump hazardous substances.



WARNING

Ensure that the exhaust pipeline cannot become blocked. If an exhaust isolation valve has been installed, ensure that the pump cannot be operated with the valve closed.



The Microvac pumps are only approved for use on applications using air, nitrogen and other inert gases.



Do not pump oxygen, hydrogen, chemically active, corrosive or flammable gases or gas mixtures, the presence of which can result in an explosion.



Refer to the Mechanical Pump and Pumping System Safety Chemical and Industrial Vacuum Systems Safety Manual (supplied with the pump), Edwards Publication Number P400-40-100 for recommendations.

Consult Edwards for specific applications assistance prior to operating the pump for hazardous applications.

Ensure that the Microvac pump is suitable for the application. Refer to the Edwards guidelines on vacuum pump and vacuum system safety (see the associated publications at the end of the Contents list at the front of this manual).

Installation of the Microvac pump must be performed by a suitably trained and supervised technician. Obey the safety instructions listed below when the pump is installed, especially when connecting the pump into an existing system. Details of specific safety precautions are provided at the appropriate point in the instructions.

- Wear appropriate safety clothing when there is potential for contact with contaminated components.
- Vent and purge the vacuum system before installation work is started.
- Ensure that the installation technician is familiar with the safety procedures which relate to the pump oil and other products handled by the pumping system. Take suitable precautions to avoid the inhalation of oil mist and excessive skin contact with pump oil, as prolonged exposure can be harmful.
- Disconnect the other components in the pumping system from the electrical supply to prevent accidental operation.

3.2 System design considerations

Consider the following points when designing the pumping system:

- Use a suitable valve to isolate the pump from the vacuum system if there is a need for the pump to warm up before pumping condensable vapours, or to provide additional system protection when the pump is switched off.
- Avoid high levels of heat input to the pump from the process gases, otherwise the pump may overheat and seize.
- If the pump is used in a high ambient temperature and has a high gas throughput, the temperature of the pump body may exceed 70 °C (158 °F) and must be fitted with suitable guards to prevent contact with hot surfaces.
- Ensure that the exhaust pipeline cannot become blocked. If an exhaust isolation valve has been installed, ensure that the pump cannot be operated with the valve closed.
- Provide for a purge of inert gas when the pumping system is shutdown to dilute dangerous gases to safe concentrations.

3.3 Unpack and inspect



WARNING

When positioning the pump use suitable lifting equipment to prevent injury to personnel. Ensure that the system is not lifted by the motor eye-bolt, as the motor eye-bolt is not intended to lift the suspended weight of the system. Injury to personnel and/or damage to equipment can result. Refer to [Section 2](#) for pump mass information.

Remove all packing materials, remove the pump from its packing box, remove the protective covers from the inlet and exhaust ports and inspect the pump. If the pump is damaged, notify the supplier and carrier in writing within three days; state the item number of the pump together with the order number and supplier's invoice number. Retain all packing materials for inspection. Do not use the pump if damaged.

If the pump is not used immediately, replace the protective covers. Store the pump in suitable conditions as described in [Section 6](#) of this manual.

3.4 Locate the pump



WARNING

Use suitable lifting equipment to move the pump. Refer to [Section 2](#) for pump mass information.

Locate the pump close to the equipment being evacuated so that the vacuum, water and exhaust connections can be conveniently made without creating a hazard to personnel safety. Provide adequate space around the pump for servicing and maintenance.

Mount the pump on a rigid foundation, such as a concrete floor, and level with shims or by grouting. Mount the pump to the foundation ensuring not to put strain or twist in the pump housing. See [Figures 4 and 5](#) for foundation mounting dimensions. The pump should be mounted to the floor using the four (4) pre-drilled mounting holes in the pump base.

Remove the protective caps/covers from the inlet and exhaust flanges just prior to installing piping. If the pump is to be used in temperatures below freezing, drain the water jacket to prevent cracking the housing; blow out the water jacket. If the unit will be stored for a period of time before commissioning, follow the same procedure.

3.5 Inlet piping



WARNING

Inlet vacuum piping should be adequately supported. Ensure the piping is secured and will not cause a trip hazard.

CAUTION

Ensure the system to be evacuated and connecting lines are clean and free of weld splatter, dirt or grit. Foreign debris entering the pump can cause failure and possibly damage the internal parts. Adequate traps, filters or screens should be permanently installed if the potential for particles greater than 0.25 mm (10 microns) are anticipated on entering the pump. Oil purification is required if a significant amount of particles greater than 0.25 mm (10 microns) are pumped. The inlet pressure must not exceed 1.013 bar (760 Torr).

All pipe lines should be as short as possible and be no smaller than the inlet to the pump. If long lines can not be avoided, increase the pipe diameter by 50 % or more over the pump inlet diameter. Conductance of long lines must be checked and the line sized large enough, or pumping speed of the system will be negatively impacted. When connecting the pump to the system, provide a vertical pipe at least 610 mm (24.0 inch) long between the pump and the system if the pump inlet is located below the system inlet. If the pump is located above or level with the system inlet, provide an inverted “U” pipe to serve as a trap for system dirt and prevent migration of pump oil toward the system inlet. Ensure all vacuum piping connections are tight. If an inline filter is being used, install according to [Figure 6](#). It is advisable to install a flexible connection between pump inlet and vacuum piping to reduce vibration (See [Figure 7](#)).

A full-opening high vacuum valve is recommended to facilitate start-up and for checking the pump blank off pressure.

Figure 6 - Inlet piping configurations

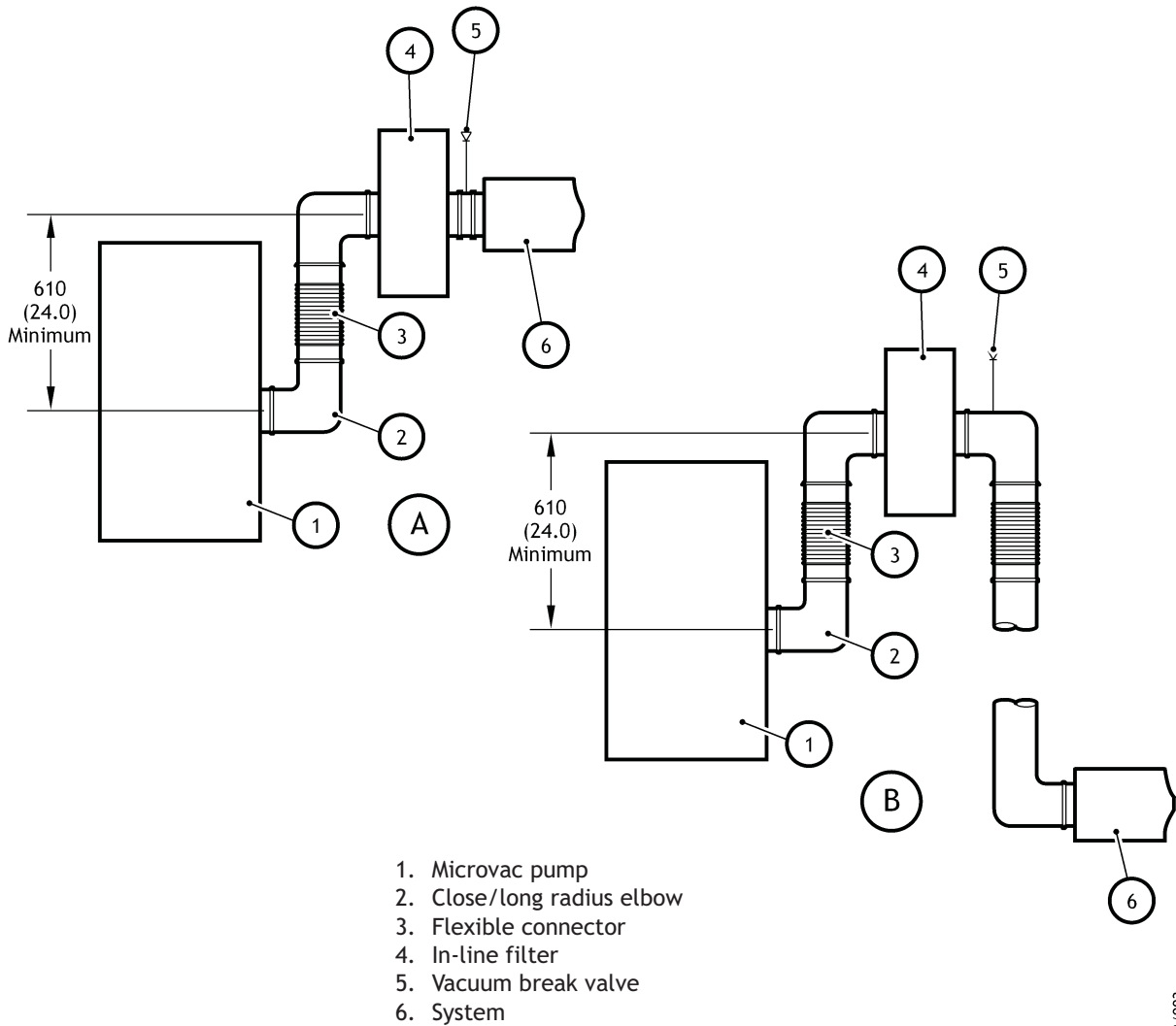

dcs/8822/003

3.5.1 Vacuum access port locations

Vacuum access ports are conveniently located on the pump and provide 6.4 mm (1/4 inch) or 12.7 mm (1/2 inch) access (Refer to Figure 2 items 7 and 12 and Figure 3 items 6 and 19). The pipe plugs can be replaced with a small vacuum ball valve to which a gauge can be connected. If a McLeod gauge is used, a synthetic, thick-wall, smooth-bore tubing such as Tygon should be used for a flexible connection. The gauge should be located approximately 610 mm (24.0 inch) above the port to prevent oil from entering the gauge.

3.6 Exhaust piping



WARNING

Do not block the exhaust of the pump. If this happens, damage to the equipment and injury to personnel can result.



WARNING

Vacuum piping should be adequately supported. Ensure the piping is secured and will not cause a trip hazard.



WARNING

The pump exhaust pressure must not exceed 483 mbar (7 psig). If this happens, damage to equipment and injury to personnel can result.



WARNING

Remove the plastic plug from the exhaust port prior to operating the pump. The pump must not be operated unless it is installed in an appropriate vacuum system.



WARNING

Exhaust filters fitted to 212-J and 412-J pumps must be drained to prevent hazardous back pressure from developing. Increased back pressure can result in damage to the pump and injury to people.

CAUTION

Do not place a valve in the exhaust line. If a valve must be installed in the line, a relief valve must also be inserted between the reservoir and the valve. The relief valve should be equal in size to the line, and set to open at 138 mbar (2 psig).

The pumps emit tiny oil droplets into the exhaust of the pump. Edwards recommends the use of exhaust filters to prevent these droplets from accumulating in the exhaust piping of the system or where the piping terminates. The oil and condensables will coalesce inside the piping and return to the pump reservoir or be collected inside the filter housing.

For those 212-J and 412-J pumps that do not use an exhaust filter, it is recommended that the exhaust be piped horizontally a short distance and tied into a vertical exhaust pipe. The lower vertical exhaust pipe must be at least 305 mm (12 inch) long and terminated with a plug or drain cock to allow removal of moisture and/or contaminated oil before it can sufficiently accumulate and drain back into the pump oil reservoir (See [Figure 7](#)).

For 212-J and 412-J pumps with an exhaust filter, the vertical collection pipe is not required. These filters collect the coalesced oil and condensables inside the filter housing. The housing must be drained of fluids using the drain cocks. Failure to drain the oil from exhaust filters will result in decreased pump performance and significantly increased back pressure.

The exhaust pipe should be no smaller than the pump exhaust outlet and sized as short as possible. Pump exhaust will contain a small amount of oil and should be handled in a manner consistent with applicable federal and local regulations. If exhausted outside the building, point the end of the exhaust pipe downward to prevent the entrance of rain water.

Oil mist separators are available from Edwards which can eliminate oil fog in the majority of applications. The separator will not remove noxious or toxic gases and must be run to a suitable trap. Consult Edwards for recommendations.

Figure 7 - Exhaust piping

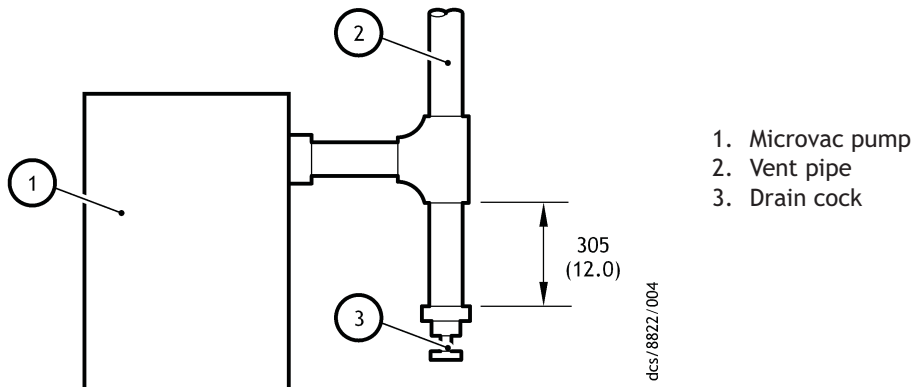

3.7 Electrical connections



WARNING

Install electrical cables while ensuring not to create a trip hazard that could result in injury to personnel.



WARNING

Installation of the electrical connections should be performed by a competent technician familiar with vacuum systems, pumps and controls. The system should be wired as to not create a hazard due to power loss or re-initializing the pump after a power loss. If a power loss occurs, the system should have a manual reset for controls before restart.



WARNING

Ensure that the electrical installation of your pump-motor conforms with your local and national safety requirements. It must be connected to a suitably fused and protected electrical supply and a suitable earth point.

We recommend that you connect the electrical supply to the motor through a starter or a circuit breaker which has thermal over-current protection which can be adjusted to suit the full-load current ratings shown on the motor rating plate. The fuse ratings must be calculated by a qualified electrician. The supplier of your thermal over-current protection device may specify fuse ratings to ensure correct operation of the over-current protection device. Ensure that the fuse you use is suitable for the starting currents given on the motor rating plate.

CAUTION

Ensure proper voltage, starters and overloads are supplied to the motor, and proper voltage supplied to the solenoid coil. The pump and/or solenoid may fail to operate if voltage is less than 90 % of rated.

The pump electrical schematic is shown in [Figure 8](#).

Install a motor starter with safety device within easy reach of the operator.

Connect the solenoid valve(s).

Connect the motor so that the pump shaft rotates clockwise when viewed from the drive end. See [Section 4.1](#) for pre-start check procedures.

Figure 8 - Electrical schematic

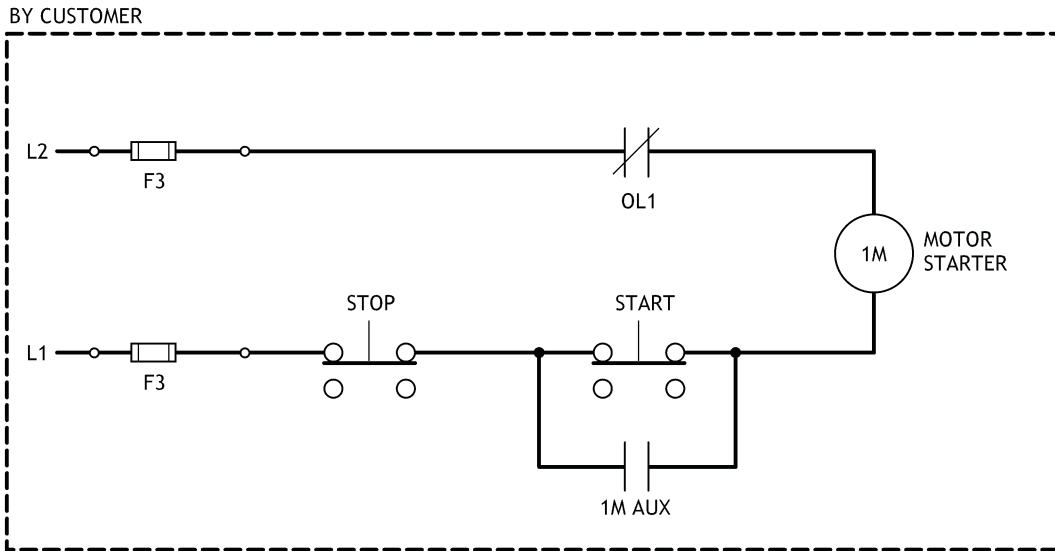
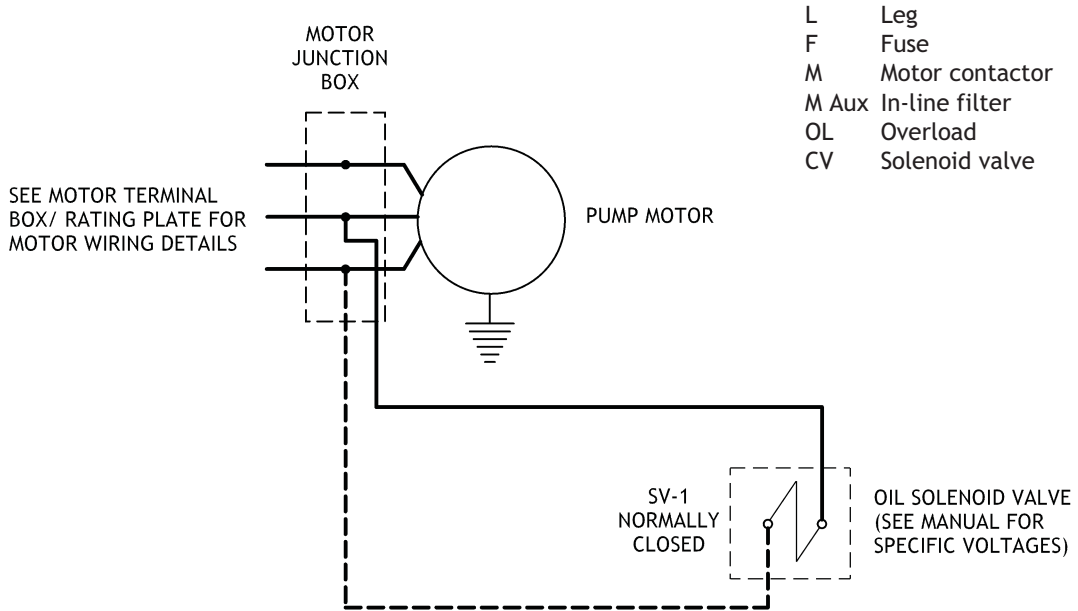

dcs/8822/005

3.8 Cooling



WARNING

The temperature of the external pump surfaces can exceed 70 °C (160 °F) and cause injury to personnel. Hot surfaces can be found where the pump lubricant is located.

CAUTION

Do not start the pump if the oil temperature is below 13 °C (55 °F).

The Microvac pump is water cooled and must be connected to a water supply.

The 1/2 inch NPT water inlet connection is located in the pump housing on the drive side near the bottom (Refer to Figure 2 item 6 and Figure 3 item 16).

Insert a valve in the water inlet line to regulate water flow so that the temperature of the oil in the reservoir is 60-71 °C (140-160 °F). Oil temperature kits are available that automatically control the water flow to maintain the proper oil temperature (Contact Edwards for additional information). If the pump is located outside a building and subjected to freezing temperatures, the pump water jacket should be drained or filled with anti-freeze.

The 1/2 inch NPT water outlet is located in the pump housing (Refer to Figure 2 item 5 and Figure 3 item 11).

The water outlet should be connected to an open drain to permit the operator to check the flow and temperature of the outlet water periodically. There should not be a valve or back pressure in the drain line. In some cases, cooling water must be discharged to a pressure drain. In such cases, discharge pressure must not exceed 2.41 bar (35 psig) and no block valve should be placed in discharge line unless a 2.41 bar (35 psig) relief valve is provided to protect pump from high inlet pressure.

Note: *If condensables are present in the process gas and gas ballast is operating, the cooling water supply should be adjusted to raise the operating temperature to the level for gas ballast (Refer to Section 4).*

3.9 Pump lubrication

The performance of this pump depends largely on the type of oil used. An initial charge of oil is included with each pump. This standard oil is V-Lube F which is recommended for general operating conditions in a relatively clean environment. V-Lube F is a multi-grade petroleum oil fortified for oxidation protection, containing detergent dispersants with excellent flow characteristics at low temperature.

If the pump is to be operated at vacuum levels that cause the oil temperature to exceed 71 °C (160 °F) for extended periods of time, a heavier grade oil should be used. V-Lube G is available for oil temperatures up to 94 °C (200 °F).

Special operating conditions may require the use of special oils. Consult Edwards for specific recommendations when other than regular petroleum oils are being used.

3.9.1 Initial oil fill



WARNING

The oil fill plug on the top of the pump serves a dual purpose. It is an oil fill port and an over-pressure device that opens at between 8 and 14 psig. This device is to protect the pump from oil box over-pressure and possible side cover fracture. The 412J pumps are fitted with two oil fill plugs, ensure at least one of these is free from obstruction i.e. not connected to anything.

CAUTION

Starting the Microvac pump when the oil temperature is below 13 °C (55 °F) can result in excessive wear and galling damage to the moving parts.

The Microvac pump is shipped with an initial charge of oil; 15 litres (4.0 gallons) for the 212-J and 45 litres (12 gallons) for the 412-J. Before connecting the suction manifold, slowly rotate the pump through two (2) revolutions. This will distribute the oil throughout the pump interior.

This page has been intentionally left blank.

4 Operation

4.1 Pre-start check

CAUTION

If the paddle wheel does not rotate, stop the pump immediately. Check the operation of the solenoid. If the solenoid is operating correctly, check the oil lines for blockage.

Note: Momentarily jog the pump for at least two revolutions.

Jog the motor momentarily while observing pump rotation. If the pump does not rotate in a clockwise direction, interchange any two of the three-phase leads.

Ensure the oil solenoid valve operates properly by checking the oil flow indicator. The paddle wheel should rotate after system pressure is below 600 mm Hg (6 inch Hg at inlet). Solenoid operation is also apparent as it will create a magnetic field and become warm.

The oil solenoid valve is normally closed and must be energized when the pump starts.

The pressure differential between the oil reservoir (atmospheric pressure) and the pump cavity (vacuum) forces the oil to the bearings and into the pump cavity. The oil lubricates the moving parts and also creates an oil seal.

Oil starts to flow at 800 mbar (600 Torr). At 533 mbar (400 Torr) the flow is approximately 50 %. From 133 mbar (100 Torr) to blank-off, flow is 100 %.

Note: 533 mbar (400 Torr) must be reached within 10 minutes or a force-feed lubrication system is required to provide adequate oil flow to the pump cavity.

4.2 Pump start



WARNING

Solenoid may become hot during operation.

CAUTION

Do not start the pump if the oil temperature is below 13 °C (55 °F).

Note: New belts usually lose some tension during initial operation and should be re-checked during the first few days of operation. Always tension the belts according to the specifications of the belt manufacturer. Excessive tension can induce unnecessary loading on the blower bearings, while extreme over-tensioning may cause the shaft to break as a result of fatigue.

1. Turn on the cooling water supply.
2. Ensure the equipment being evacuated is properly cleaned and all vacuum breaks are closed.
3. Depress the **START** button and check the solenoid valve for proper operation.
4. Open the pump inlet valve.

4.3 Gas ballast operation

CAUTION

When opening gas ballast valve, do not open past third marking on valve stem (See Figure 9).

Open the gas ballast valve for maximum efficiency. Adjust the ballast by turning the valve for desired rate. Full gas ballast will cause pump temperature to rise and is normal. For maximum effect of gas ballast, pump should operate at approximately 71 °C (160 °F). The operating temperature can be raised by throttling the cooling water. Consult Edwards for available oil temperature control kits.

If pumping water vapour in excessive quantities, the oil may become contaminated. The oil can be purified by running the pump with full gas ballast while the pump is isolated from the system. When excessive contaminants are present, indicated by high oil level, or thinning, formation of varnish, etc., the oil should be replaced.

Note: For dirty applications where condensable contaminants (asphalt, pitch, epoxies, etc.) other than water vapour are present, the pump should be operated near 71 °C (160 °F).

Switch on inert gas purge to remove air from the pump and exhaust pipeline before the process starts.

Note: Edwards recommends obtaining and reading the Vacuum Pump and Vacuum System Safety manual (publication number P300-20-000), available from Edwards or the supplier.

- The gas ballast check valve should be inspected every six months for wear or a broken spring when operating on an eight (8) hour a day basis; 3 months for twenty-four (24) hour a day operation.
- The gas ballast valve should be closed when the pump is stopped. If the valve is open, gas will be drawn into the pump through the check valve and the vacuum manifold will be pressurized with atmospheric air. If desired, a solenoid valve attached to the gas ballast inlet and electrically connected to the motor leads can be used to turn off the gas ballast automatically on pump shutdown. Contact Edwards for additional information.

Figure 9 - Gas ballast setting

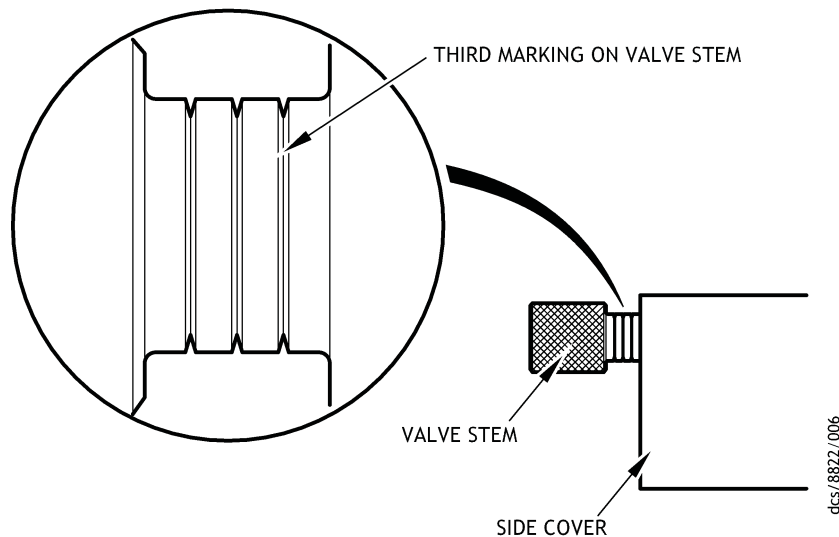

- When a pressurized gas is used to ballast the pump, the pressure must be reduced to 2 psi maximum. The use of higher pressures may damage the pump.
- Opening the gas ballast slightly will quiet discharge valve noise when the pump is blanked off, but will prevent reaching the lowest ultimate pressure.

- To maintain a low blank-off noise level on a continuous basis, the valve seal washer can be removed from the valve stem. This will provide a small amount of ballast at all times even when the valve is fully closed. It will also break vacuum when the pump is stopped. If the vacuum break is not permissible, solenoid valves may be installed. With the washer removed and with the gas ballast valve closed, blank-off pressure will be approximately 200 microns. The seal washer can be reinstalled when ballast on a continuous basis is no longer required. Care should be taken not to damage the seal washer if reinstallation is anticipated.

4.4 Pump stop

- Close the inlet valve to system.
- Stop the motor and break vacuum unless system dictates otherwise.

Note: *The oil solenoid valve closes automatically when the pump is stopped or a power failure occurs. This will prevent the pump and vacuum system from being flooded with oil.*

4.5 Operating notes



WARNING

The oil fill plug on the top of the pump serves a dual purpose. It is an oil fill port and an over-pressure device that opens at between 8 and 14 psig. This device is to protect the pump from oil box over-pressure and possible side cover fracture. The 412J pumps are fitted with two oil fill plugs, ensure at least one of these is free from obstruction i.e. not connected to anything.

If large amounts of air pass through the pump, it may become warm and, under severe conditions, hot. This is not an indication of malfunction. The pump is designed for high vacuum work and should not be operated at pressures greater than 533 mbar (400 Torr) for more than 10 minutes or at intermediate vacuums for periods which cause oil temperature to exceed 93 °C (200 °F).

For optimum pump operation, the oil temperature in the oil reservoir should be 60-71 °C (140-160 °F) with the pump operating on the system or process. Oil temperature can be measured by inserting a thermometer in the fill hole or by contact pyrometer on oil block near the solenoid. If the pump is to be operated with oil temperature in excess of 71 °C (160 °F), the use of a heavier viscosity oil is recommended (Refer to Section 3.9).

When starting the pump or handling large amounts of air, oil vapour in the form of smoke will be released from the exhaust. This is not an indication of trouble. The volume of smoke will decrease as the pressure in the system decreases.

Note: *Edwards offers a closed type oil mist separator that will eliminate exhaust oil smog but still requires exhausting to outside. Contact a Edwards representative for information.*

If the pump has been shut down for an extended period of time, it will be necessary to turn the pump over at least two (2) revolutions by momentarily jogging before starting to insure the free movement of parts.

Low oil temperature can cause overloading when starting the pump and possibly prevent the pump from sealing. Microvac pumps should not be started when the oil temperature is below 13 °C (55 °F). Optimum operating oil temperature after starting is between 60-71 °C (140-160 °F). Opening the gas ballast valve will help to warm the oil. A water miser (Refer to Section 7.4) is recommended to automatically control the oil temperature. Contact a Edwards representative for information.

This page has been intentionally left blank.

5 Maintenance

5.1 Safety information



WARNING

Obey the safety instructions given below and take note of appropriate precautions. If not, injury to people and damage to equipment can occur.

- Ensure that maintenance is performed by a suitably trained and supervised technician. Obey local and national safety requirements.
- Ensure that the maintenance technician is familiar with the safety procedures which relate to the pump oil and the products processed by the pumping system.
- Check that all the required parts are available and of the correct type before work is started.
- Isolate the pump and other components from the electrical supply so that they cannot be operated accidentally.
- Allow the pump to cool (so that it is a safe temperature for skin contact) before maintenance work is started.
- Do not reuse O-rings and seals if damaged.
- After maintenance is complete, recheck the direction of pump rotation if the electrical supply has been disconnected.
- The pump and pump oil will be contaminated with the process chemicals that have been pumped during operation. Ensure that the pump is decontaminated before maintenance and that adequate precautions to protect personnel from the effects of dangerous substances if contamination has occurred.
- Do not touch or inhale the thermal breakdown products of fluorinated materials which may be present if the pump has been heated to 310 °C (590 °F) and above. Fluorinated materials are safe in normal use but can decompose into very dangerous substances (which may include hydrofluoric acid) if heated to 310 °C (590 °F) and above. The pump may have overheated if it was misused or if it was in a fire. Health and Safety Data sheets for fluorinated materials used in the pump are available on request: contact Edwards or the supplier.
- If necessary, maintain the motor as specified in the manufacturers information supplied with the motor.

5.2 Leak detection

A leak test should be performed if ultimate vacuum cannot be achieved. A proper leak test will isolate sections of the piping until the leak-source is found. The standard vacuum piping is shown in [Figure 10](#). The use of a leak detector will speed the process for detecting leaks. Contact a Edwards representative for information.

5.3 Maintenance plan

A typical maintenance plan for the Microvac pump is provided in Table 5.

Figure 10 - Typical vacuum system piping

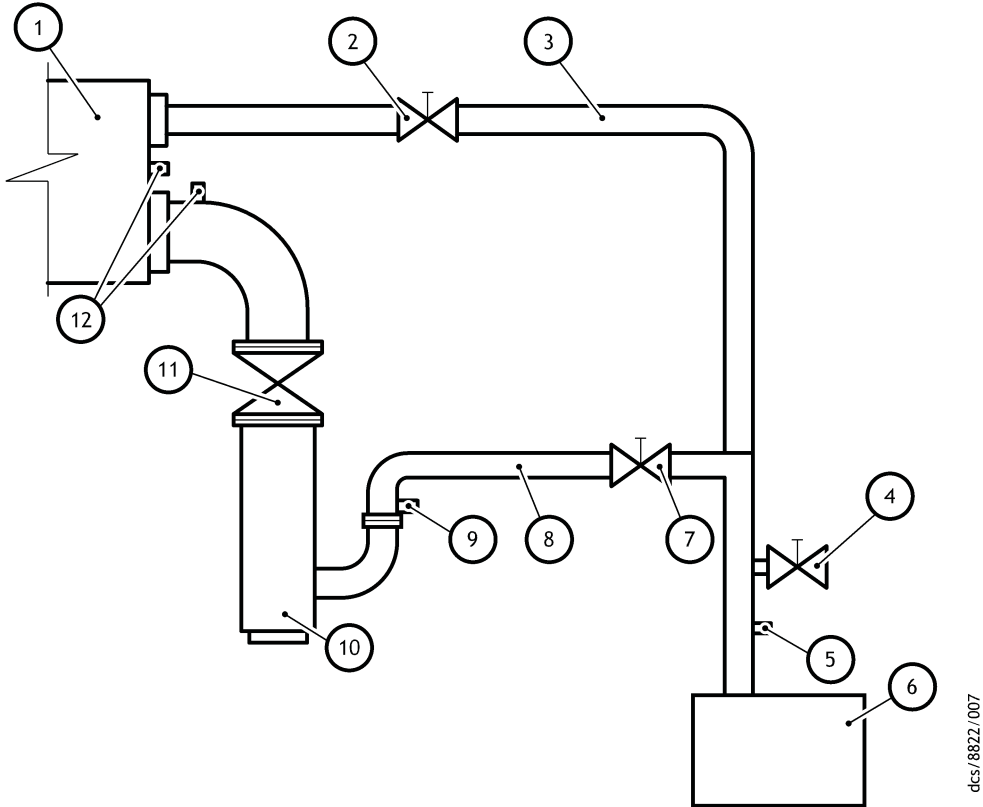

- | | |
|-------------------------|--|
| 1. Vacuum chamber | 7. Optional foreline valve connection location |
| 2. Roughing valve | 8. Optional hold pump connection location |
| 3. Roughing line | 9. Gauge port |
| 4. Air inlet valve | 10. Vapour pump |
| 5. Gauge port | 11. Valve |
| 6. Mechanical fore pump | 12. Alternate chamber gauge port location |

Table 5 - Maintenance plan

Operation	Frequency
Inspect oil level	Daily
Check operating temperature 60-71 °C (140-160 °F)	Daily
Replace oil	Application dependent
Inspect valve decks	6 months
Inspect pulleys and belts	6 months
Inspect gas ballast valve	6 months
Inspect bearing condition	12 months
Clean the motor and drive	12 months
Inspect taper lock bushings on pulleys	After break in and 12 months

5.4 Oil change



WARNING

Oil will be hot if pump was just operating. Allow sufficient time for the pump to cool prior to changing oil.



WARNING

The oil fill plug on the top of the pump serves a dual purpose. It is an oil fill port and an over-pressure device that opens at between 8 and 14 psig. This device is to protect the pump from oil box over-pressure and possible side cover fracture. The 412J pumps are fitted with two oil fill plugs, ensure at least one of these is free from obstruction i.e. not connected to anything.

- Lockout all energy sources connected to the pump and vent to atmosphere.
- Review the process contaminants and select proper personal protective equipment (PPE) to protect against media contact.
- Using the drain valve, drain the oil into a suitable container for disposal. Use only Edwards recommended oils when refilling the pump. Refer to [Section 2](#) for fluid type and quantities. Fill the pump until the sight glass reaches the 3/4 mark.
- Check the pump and system for potential hazardous conditions. Restore energy sources.

5.5 Oil level check

- Check oil level daily. The oil level should be at center of sight glass when the pump is off or in lower half while pump is operating at high vacuum. The level will change depending on inlet pressure. In most cases, oil is added after operating the pump for a short period of time.
- To avoid the loss of oil out the fill hole, do not add oil to the pump when in operation.

Note: When pumping gases that contain water vapour, it may be necessary to remove the water that condenses in the pump reservoir sump. Stop the pump and wait at least 1/2 hour for the oil and water to separate. Open the oil drain valve and drain water; close the valve when oil flow starts. The interval is process dependent and varies with the amount of water vapour and oil temperature. Operating the pump with the oil temperature near 71 °C (160 °F) will minimize formation of water but not eliminate it.

Water entrapped in the oil will decrease ultimate vacuum and increase pumpdown times. The presence of water in the oil is evident by a milky appearance of the oil when running.

5.6 Valve deck maintenance

- Lockout all energy sources connected to the pump.
- Drain the oil as described in [Section 5.4](#).
- Remove the reservoir cover, oil baffle, and each valve deck while being very careful not to drop any hardware inside the pump.
- Replace worn valve deck or valve deck parts. Reinstall valve decks with new gaskets. Reinstall oil baffle with new gasket.
- Reinstall oil reservoir cover.
- Refill the oil as described in [Section 5.4](#).
- Check the pump and system for potential hazardous conditions. Restore energy sources.

5.7 Belt maintenance

- Lockout all energy sources connected to the pump and vent to atmosphere.
- Remove the belt guard cover.
- Test the belt tension with proper tester.

Note: *New belts usually lose some tension during initial operation and should be re-checked during the first few days of operation. Always tension the belts according to the specifications of the belt manufacturer. excessive tension can induce unnecessary loading on the pump and motor bearings, while extreme over-tensioning may cause the shaft to break as a result of fatigue.*

- Replace worn pulleys.
- Replace all belts at one time when any one requires changing. Check tension frequently during the first few days of operation. Never apply belt dressing. If customer supplied belt or pulleys are used, follow the manufacturer's recommended installation procedures.
- Reinstall belt guard cover.
- Check the pump and system for potential hazardous conditions. Restore energy sources.

5.8 Drive belt tension

Remove the belt guard. At approximately the center of the span between drive and driven pulleys, apply force to the belt and ensure the resulting deflection provided in Table 6.

Table 6 - Belt tension

Pump	Force		Deflection	
	N	Pounds	mm	Inches
212-J	13.3 - 22.2	3 - 5	11.0	7/16
412-J	22.2 - 31.2	5 - 7	13.0	1/2

If necessary, adjust the tension by raising or lowering the nuts on the motor support jack screws. Tighten the jackscrew nuts securely after adjustment is complete.

Note: *Maintenance of proper belt tension is important. Excessive over-tightening of the belts is harmful to the shaft bearings, while under-tightening will allow the belts to slip.*

5.9 Gas ballast check valve replacement

- Replace the gas ballast valve(s) every two (2) years, if gas ballast is used on a regular basis.
- Lockout all energy sources connected to the pump.
- Remove the stem valve.
- Use an O-ring pick or suitable tool to pull out the gas ballast check valve. Replace the valve if the spring is damaged or broken.
- Reinstall the stem valve.
- Check the pump and system for potential hazardous conditions. Restore energy sources.

5.10 Fitment or replacement of the motor (412J models only)



WARNING

A new safety review may be required following fitment of any motor. Particular attention should be made to the effectiveness of the drive guard to restrict finger access to the motor shaft and all other rotating parts.

The following motors can be fitted to 412J Pump Modules with the Universal Motor Mounting Platform attached.

Note: This is valid for pump modules with a serial number above 076227658.

Table 7 - Motors that can be fitted to 412J pump models

Motor Frame Size	Line frequency	Motor Pulley	Collar Bolt Position	Platform Nominal Inclination	Drive Belt Size	Standard Pump Article Codes
IEC D160M	50 Hz	6 inch	A	-0.5 °	B105 (L=2720)	900412014501
	60 Hz	5 inch	B	-4.1 °	B105 (L=2720)	
NEMA 215T	50 Hz	6 inch	C	-7.7 °	B105 (L=2720)	
	60 Hz	5 inch	C	-3.0 °	B105 (L=2720)	900-412-014
NEMA 254T	60 Hz	5 inch	B	-4.0 °	B105 (L=2720)	

Figure 11 - Collar bolt positions and motor frame sizes

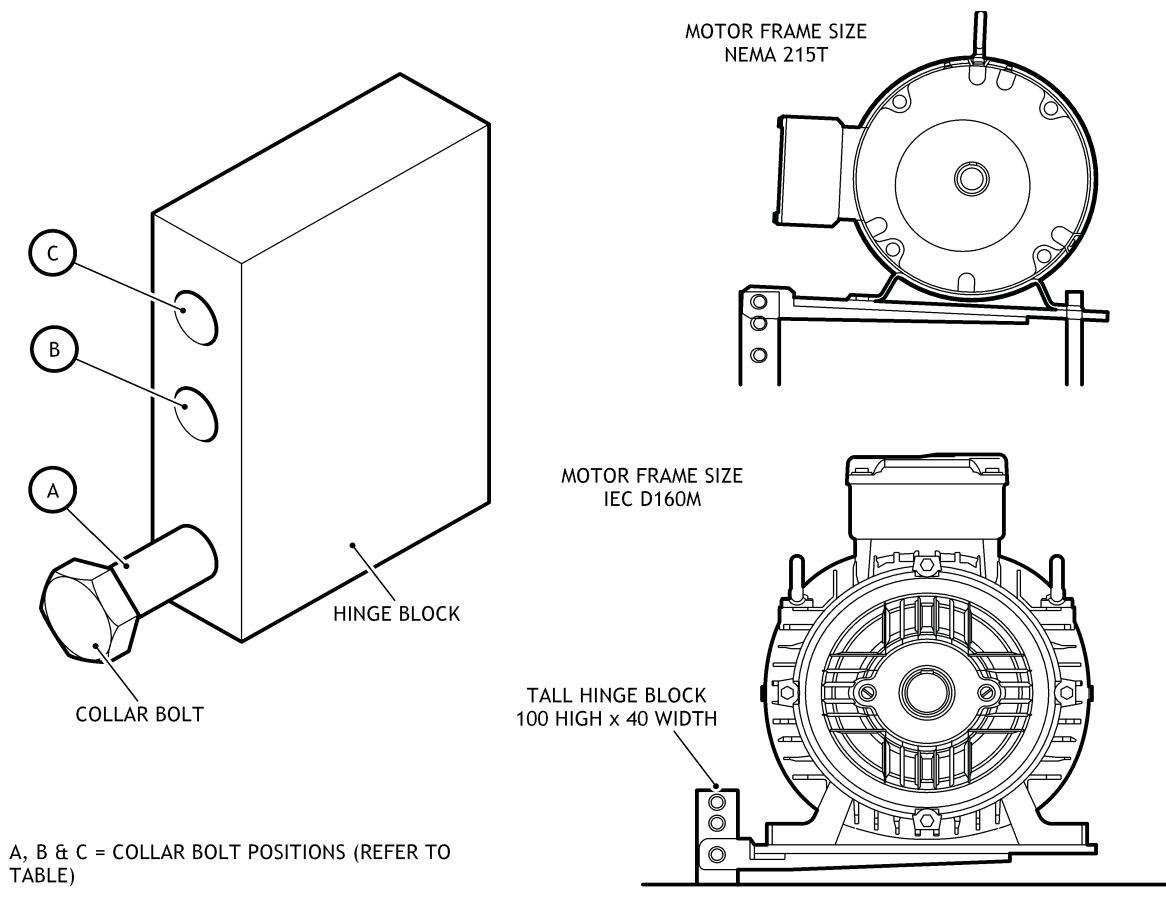

A, B & C = COLLAR BOLT POSITIONS (REFER TO TABLE)

dcs/8822/008

New IE3 Efficiency Motors

When replacing your existing motor with one of the new IE3 efficient motors, it may be necessary to remove the extra motor finger guard which is mounted to the drive belt guard to ensure correct fitment of the motor. This is due to the different dimensions of the new motors. A safety review should be carried out after a replacement motor has been fitted and finger access should be checked.

5.11 Fault finding

A list of fault conditions and possible causes is provided in [Table 8](#). If unable to rectify the fault using the table, call your nearest Edwards Service Center for help.

Table 8 - Fault finding guide

Symptom	Probable Cause	Recommended Solution
Unsatisfactory Vacuum at Pump Inlet	Contaminated or insufficient oil. Solenoid oil valve not operating properly or inoperative. Intake flange or cover bolts are loose. Oil manifold or integral oil distribution leaking. Oil level sight glass leaking. Exhaust valve not sealing.	Check oil level; utilize gas ballast. Drain and wipe out reservoir and valve chamber. Refill with proper oil. Check and if necessary, clean and/or replace solenoid valve or coil. Tighten flange and side cover bolts at regular intervals. Tighten plugs and manifold screws. Carefully tighten screws. Disassemble, clean and check all parts thoroughly. Replace any damaged or worn parts.
Excessive Pump Noise	Pump seizes or knocks excessively; internal parts severely worn or broken.	Disassemble piston assembly. Replace broken or worn parts.
Excessive Pump Noise	Leakage in vacuum system.	Check system as described in Section 4 .
Excessive Pump Noise	Pump knocking abnormally.	Knocking is normal at blank-off. Check oil level and oil solenoid valve for proper operation. Broken parts or foreign material in the pump. Disassemble and remove foreign material in the pump. Replace broken parts as required.

Table 8 - Fault finding guide (continued)

Symptom	Probable Cause	Recommended Solution
Motor stops or will not start.	Pump seizure resulting from insufficient lubrication or presence of foreign material.	Check solenoid valve for proper operation. Disassemble and remove foreign material. Ensure oil lines are not clogged. Smooth minor scoring with #500 emery cloth and wash thoroughly then oil before installing. Note: a certain amount of scoring to the piston, cylinder and other parts usually will not seriously affect the vacuum obtainable so long as scoring is not in a continuous gouge around the circumference of the piston surface.
	Thermal overload units in motor starter fail.	Check Capacity of thermal overload units by comparing ampere rating on motor nameplate with overload table inside starter box. If necessary, use one (1) size larger than standard.
Pump does not turn when motor starts.	Possible internal seizure.	Disassemble and correct.
	V-belts too loose.	Tighten V-belts (see Section 5.8).
	Cylinder flooded with excessive oil due to defective solenoid valve (Valve stuck in open position from previous shutdown, or foreign material in valve seat).	Turn pump over by hand to remove excess oil. Disassemble valve, clean and replace any worn parts. Check solenoid.
Pump turns in reverse direction when motor is turned off.	Oil viscosity too high or oil temperature too low.	Change to lighter grade oil or warm oil before filling pump (especially with low ambient temperatures). Pump should not be started when oil temperature is less than 13 °C (55 °F) (When using V-lube F). Turn pump over by hand before starting.
	Pulley(s) not keyed to shaft.	Ensure keys are in place and pulley(s) properly tightened.
	Gas ballast valve in open position on pump shut down.	Close gas ballast valve prior to pump shut down. Atmospheric air prevents reversing direction of pump piston on pump shutdown. Oil will also be prevented from back-streaming into inlet piping.

This page has been intentionally left blank.

6 Storage and disposal

6.1 Storage

CAUTION

Observe the storage temperature limits stated in [Section 2](#). Storage below -30 °C (-22 °F) will permanently damage the pump seals.

Use the following procedure to store the pump:

- Purge the vacuum system and the pump with dry nitrogen and disconnect the pump from the vacuum system.
- Shut down the pump as described in [Section 4](#).
- Disconnect the pump from the electrical supply.
- Disassemble, clean and reassemble the pump. If the pump is to be stored for long periods, loosen the drive belts and change the oil.
- Place and secure protective covers on the inlet and exhaust ports.
- Store the pump in cool, dry conditions until it is required for use. When required, prepare and install the pump as described in [Section 3](#). If the pump will be subjected to temperatures below freezing, drain or add anti-freeze to the water jacket. If the pump will be stored for more than a year, the pump must be cleaned and overhauled before re-installation.

6.2 Disposal

Dispose of the pump or any components removed from it safely in accordance with local and national safety and environmental requirements.

Particular care should be taken with components and waste oil which have been contaminated with dangerous process substances.

Do not incinerate fluoroelastomer seals and O-rings.

This page has been intentionally left blank.

7 Spares and accessories

7.1 Introduction

Edwards products, spares and accessories are available from Edwards companies in Belgium, Brazil, Canada, France, Germany, Hong Kong, Italy, Japan, Korea, Switzerland, United Kingdom, USA, and a worldwide network of distributors. The majority of these centers employ Service Engineers who have undergone comprehensive Edwards training courses.

Order spare parts and accessories from the nearest Edwards company or distributor. When ordering, provide the following information:

- Model and Item Number of equipment.
- Serial number.
- Item number and description of part.

7.2 Service

Edwards products are supported by a worldwide network of Edwards Service Centers. Each Service Center offers a wide range of options including: equipment decontamination; service exchange; repair; rebuild and testing to factory specifications. Equipment which has been serviced, repaired or rebuilt is returned with a full warranty.

The local Service Center can also provide Edwards engineers to support on-site maintenance, service or repair of your equipment.

For more information about service options, contact the nearest Service Center or other Edwards company.

7.3 Spares

Refer to the Parts manual.

7.4 Accessories

The following is a list of accessories that can be purchased by contacting Edwards.

Table 9 - Accessories

Accessories	Item number
Oil mist separator (212-J)	900-291-J24
Oil mist separator (412-J)	900-291-J25
Oil Mist Separator / Exhaust Elbow*	XXXXXXXXXX
Water miser	900-412-124
Portable oil purifier	Application dependant

* Some motors such as the IE3 efficient motors are longer in length, as a result the oil mist separator may clash with the motor fan cowl, you may require an elbow attachment to mount the oil mist separator.

This page has been intentionally left blank.

8 PFPE-prepared Microvac pumps

8.1 Summary

PFPE-prepared Microvac pumps are supplied prepared for use with Edwards PFPE mechanical pump oils, such as Fomblin YVAC 06/6 or Krytox 1506.

PFPE-prepared Microvac pumps are suitable for pumping high concentrations of oxygen.

Edwards recommends referencing publication P300-20-000 (Vacuum Pump and Vacuum System Safety) before installing and using a PFPE-prepared Microvac pump.

8.2 Installation

CAUTION

Never use hydrocarbon lubricants in a PFPE-prepared pump.

When filling the Microvac pump with oil (as described in Section 3), a suitable Edwards PFPE oil must be used. Hydrocarbon oil cannot be used.

8.3 Operation

WARNING



PFPE-prepared Microvac pumps are suitable for pumping high concentrations of oxygen, but Edwards recommends that PFPE-prepared Microvac pumps not be used for the pumping of hazardous materials.

Operation of a PFPE-prepared Microvac pump is as specified in Section 4, but take note of the warning above.

8.4 Maintenance

WARNING



Obey the safety instructions given below and take note of appropriate precautions. If not, injury to people can occur.

Take additional care if the pump (hence the PFPE oil) is suspected of overheating.

Do not touch or inhale the thermal breakdown products of PFPE oil which may be present if the pump has been heated to 260 °C (500 °F) and above. PFPE oils are safe in normal use but can decompose into very dangerous substances if heated to 260 °C (500 °F) and above. The pump may have overheated if it was misused, if it malfunctioned, or if it was in a fire. Material Safety Data Sheets for PFPE oils used in the pump are available on request: contact the supplier or Edwards.

Fomblin oil has different properties from other pump oils, therefore:

If filling the PFPE-prepared Microvac pump with Fomblin oil, Edwards recommends to check for oil leaks, particularly around the shaft seals.

If an oil leak is detected, contact the supplier or Edwards for advice.

This page has been intentionally left blank.