

EV-A Series  
DRY VACUUM PUMP

APPLICABLE TYPE

EV-A03

INSTRUCTION MANUAL



## HANDLING OF MANUAL

This instruction manual describes installation, operation, and maintenance about the EV-A Series Dry Vacuum Pump.

Be sure to read this instruction manual to operate correctly before installing and operating it. In particular, take care about the precautions for safety to the following warning words.

### DANGER

This indicates the existence of imminent hazard, which if the equipment is operated without respect to its contents, will result in death or a serious injury of the operator.

### WARNING

This indicates the existence of potential hazard, which if the equipment is operated without respect to its contents, will result in death or a serious injury of the operator.

### CAUTION

This indicates the existence of potential hazard, which if the equipment is operated without respect to its contents, may result in slight injury or less serious injury of the operator.

### CONFIRMATION

This indicates the existence of possibility, which if the equipment is operated without respect to its contents, may result in equipment damage.

The following symbols may appear on the EV-A Series Dry Vacuum Pump.



Warning — refer to manual



Warning — risk of electric shock



Warning — hot surface

<STORAGE OF THIS INSTRUCTION MANUAL>

This instruction manual describes important matters related to pump operation. Keep the manual in an easy-to-see place so that it may be available whenever required.

<Definitions of term>

Definitions of term are as follows.

Solvent: IPA, Organic solvent such as Ethanol and etc.

Condensable gas: Water vapor or mixed gas with solvent.

Clean gas exhaust: Inert gas such as nitrogen, atmosphere (exhaust dry types of gas)

\*These are one of the examples

\*Regardless of the solvent kind and its amount, contact one of our sales offices before you start operation. When you pump flammable chemical, including solvent stated above, always introduce N<sub>2</sub> through gas ballast system.

\*To vacuum solvent and condensable gas, read P.17 3.3 Gas Ballast Mechanism and P.38 6.3 About The Gas Ballast Mechanism beforehand to handle correctly.

## **1. Warranties**

Seller warrants each standard Product manufactured and sold by it to be free of defects in materials and workmanship for such period of time and under such conditions as are specified herein or as may be specified by Seller on the face of its Quotation or otherwise reduced to writing and expressly approved by Seller. The Warranty period so specified by Seller shall commence on the date of shipment from Seller to the original purchaser. If no period of time is stated, then Seller's Warranty for standard products is limited to 12 months from the date of installation, not to exceed 15 months from the date of shipment. Repair, or at Seller's option, replacement of defective parts shall be the sole and exclusive remedy under Warranty; provided that, Seller may, as an alternative, elect to refund an equitable portion of the purchase price of the Product. All warranty replacement or repair of parts shall be limited to Product malfunctions which, in the sole opinion of Seller, are due or traceable to defects in original materials or workmanship.

### **General Warranty Limitations and Exclusions**

The foregoing warranties do not cover items expendable in normal use nor those of limited life. Seller only warrants that at the time of shipment such items meet applicable specifications, but SELLER SHALL HAVE NO OTHER OR FURTHER RESPONSIBILITY THEREFOR, WHATSOEVER.

Software media and firmware media furnished by Seller in or for use with Seller's Products are warranted only to be free of defects in materials which cause failure to execute programming instructions and are not warranted against interruptions or errors in operation. Such warranty is subject to the terms and conditions of any applicable Seller license agreement, including any Seller warranty provisions stated herein.

Warranties given by suppliers of products, equipment or proprietary components not manufactured by Seller but incorporated by Seller into Products shall be passed on to Buyer, but in no event shall Seller have liability for failure of any such supplier to perform on its warranty.

All obligations of Seller under warranty shall cease in the event of abuse, accident, alteration, misuse or neglect of the Product. In-warranty repaired or replaced parts are warranted only for the remaining unexpired portion of the original warranty period applicable to the repaired or replaced parts. After expiration of the applicable warranty period, Buyer shall be charged at the then current prices for parts, labor and transportation.

REASONABLE CARE MUST BE USED TO AVOID HAZARDS. SELLER EXPRESSLY DISCLAIMS RESPONSIBILITY FOR LOSS OR DAMAGE CAUSED BY USE OF ITS PRODUCTS OTHER THAN IN ACCORDANCE WITH PROPER OPERATING PROCEDURES.

THE FOREGOING WARRANTIES ARE EXPRESSLY IN LIEU OF AND EXCLUDE ALL OTHER EXPRESS OR IMPLIED WARRANTIES, INCLUDING BUT NOT LIMITED TO, WARRANTIES OF MERCHANTABILITY AND OF FITNESS FOR PARTICULAR PURPOSE, USE OR APPLICATION, AND ALL OTHER OBLIGATIONS OR LIABILITIES ON THE PART OF SELLER, UNLESS SUCH OTHER WARRANTIES, OBLIGATIONS OR LIABILITIES ARE EXPRESSLY AGREED TO IN WRITING BY SELLER. Statements made by any person, including representative of Seller, which are inconsistent or in conflict with the terms of these warranties shall not be binding upon Seller unless reduced to writing and approved by an officer of Seller.

## APPLICATION OF THE VACUUM PUMP

- \* This vacuum pump is intended to get a vacuum source for vacuum exhaust, maintenance of vacuum condition, and a clean usage as a vacuum source for general industry. However, the above is not applicable to the case where using this vacuum pump has been judged to be usable for a use other than these by a previous arrangement with the user before purchase.
- \* When the use is going to change the process for using this vacuum pump or divert this pump to another use, please consult our business offices listed in the back. It may be necessary to change the specifications of the pump and peripheral units.
- \* ~~Using this vacuum pump to the process where existing radiation is prohibited.~~



Don't use it to exhaust the combustible gas or the dangerous fumes for the human body, etc.

## Contents

1.	ITEMS RELATED TO SAFETY	-----	8
1.1	Safety	-----	12
1.2	Types of Warning Label	-----	13
1.3	Warning Label Positions	-----	14
2.	PRODUCT CONFIRMATION	-----	15
3.	PRODUCT OVERVIEW	-----	15
3.1	Pump Body	-----	15
3.2	Electrical Equipment	-----	15
3.3	Gas ballast mechanism	-----	16
3.4	Product Specifications	-----	18
3.5	External View	-----	19
3.6	Pumping Performance	-----	20
4.	INSTALLATION OF THE PUMP	-----	22
4.1	Installation	-----	23
4.2	Piping	-----	23
4.3	Electric Wiring	-----	28
5.	OPERATION PANEL	-----	30
5.1	Operation Panel	-----	32
5.2	How to Switch LED Display	-----	36
6.	OPERATION AND STOP	-----	38
6.1	Preparations for Operation	-----	32
6.2	Operation and Stop	-----	36
6.3	About the Gas Ballast Mechanism	-----	38
7.	MAINTENANCE	-----	39
7.1	Routine Maintenance	-----	39
7.2	Inlet and Outlet Plumbing	-----	39
7.3	Lubricant	-----	41
7.4	Overhaul	-----	42
7.5	Removal of the Pump	-----	43
8.	TROUBLESHOOTING	-----	44
8.1	Primary Trouble	-----	45
8.2	Pump Malfunction	-----	45
9.	SCRAPPING METHOD	-----	45
10.	PRECAUTIONS ON RETURN OF PRODUCT	-----	45
10.1	Note	-----	45
10.2	Returning Procedure	-----	45
	< Notice >		
	Return Notice Sheet		

## 1. ITEMS RELATED TO SAFETY

### 1.1 Safety

This instruction manual describes the following items related to safety.  
Read this manual carefully before operating this product.  
Safety precautions are also described in each related sections.

#### **DANGER**

Do not use this product for pumping harmful or flammable gas.

Turn off the main switch on the pump and disconnect power cable before servicing. Do not supply power before completion of service work.

#### **WARNING**

Because the temperatures of the inlet and outlet pipes of the pump become high, arrange them so that they may not come in contact with the human body and combustible materials.

Perform leak check after piping maintenance. Apply pressure from exhaust piping and pressurize up to 0.05 MPa for pressure leak check.

Wiring work must be done by qualified workers.

This product is not equipped with earth leakage breaker (ELB) and emergency off switch (EMO). Follow the local regulations when installing this product.

Be sure to perform grounding, otherwise an electric shock may be caused by electric leakage.

Pump remains hot during/after operation. Avoid direct skin contact otherwise it may cause burn. Keep combustible materials away from the product. Do not attempt to service the product when it is hot.

Do not remove packaging covers during operation.

### CAUTION

Do not step on the pump, otherwise falling or turnover may be caused. Do not place anything on the pump as it may damage the product.

Do not lift the pump by yourself. Lift the pump by hand with two (2) persons.  
Do not use sling or the like to lift the pump as the handles are not designed to be used with slings.

Use high corrosion-resistant materials for pipes and parts used on both inlet port and outlet port sides.

Pump starts operation as soon as power is supplied if pump run command presents.  
Take safety precautions and make sure pump inlet and outlet are plumbed properly before supplying power.

Use lubricant oil specified on P.18 (3.4. Product specification) section.

Do not overfill more than upper limit as it may damage the product.

Refill oil immediately when oil level is low as it may cause severe damages to the product.

## CONFIRMATION

Don't pile packed pumps and don't lay each pump on its side in any case; otherwise the damage may be caused to the pumps.

Keep space, 100mm or more at front and rear side, 50mm or more at lateral side, to secure good ventilation for cooling. Bad ventilation can cause pump overheat which results in unpredicted pump failure.

Do not place the device which could be heat source at the front of pump, and consider that air ventilation temperature around pump is kept at 15 to 30 degrees C. High-temperature ventilation heats up pump and causes pump failure.

For Input signals (Pin No. 1-9, 2-10, 3-11, 4-12), apply a voltage of 24V DC on the pump controller side. Don't apply a voltage on the equipment side; otherwise the controller may go wrong.

Pump stops in emergency off state if STOP/RESET switch on the controller is pressed during pump operation with driving connector under direct power input. To restart the pump, turn power off (wait until LED light goes off) then turn it back on.

Pump stops in emergency off state if STOP/RESET switch on the controller is pressed during pump operation under remote control. To restart the pump, deactivate pump run command (pin No. 1-9) then apply the command again or press STOP/RESET switch.

In the states that "LOCAL/REMOTE Selection Switch" in the I/O connector (CN2) is open – means Pin No.3-11 is open circuit -, external signal mode is not available. In this case, handling by operation-panel is required.

Pump stops if the controller is removed during operation.

Frequent power supply to the inverter may shorten the inverter life. Remote operation described in 6.2.3 section P.36 is recommended if frequent RUN/STOP is necessary.

## CONFIRMATION

Always use gas ballast mechanism (optional) when the pump needs to exhaust solvent gas and water vapor.

Air gas ballast mechanism has a built in filter to protect the pump from foreign materials in the atmosphere. When pump is used in dusty environment the filter may get clogged and reduce ballast gas flow into the pump which causes a failure to prevent condensation in the pump. Install the pump in clean environment.

Maximum supply pressure for N<sub>2</sub> gas ballast is 0.05MPa.  
Do not over pressurize as it may damage the pump.

When using gas ballast valve, while the beginning operation of which the pump is still cold, "gas ballast capability" cannot be fully performed. If it is necessary to exhaust water vapor and other condensable gases, warm-up the pump enough (more than 1 hour after running) and use gas ballast mechanism. While the pump is still cold, "gas ballast capability" cannot fully perform and condensable gas (eg, solvent gas) condenses inside the pump of which may lead to the pump stop.

When the pump stops and the gas ballast valve still remains "open" state, air is introduced from the gas ballast valve into the pump. This cannot keep vacuum condition of the pump. If it is necessary to keep vacuum of the pump and/or equipment, attach shut off valve at the top of the pump inlet to hold vacuum condition and shut it off before the pump is stopped.

When condensable gas such as water vapor is pumped, please keep it running for about 1 hour opening the inlet port. There is a possibility of pump failure arising from corrosion or other factors when condensed moisture, etc. remains inside the pump.

The condensable gas, which isn't condensed in the pump, might be condensed in the exhaust piping. Take care of the condensate not to move back into the pump.

### <Notice>

Please fill out Return Notice Form attached end of this manual and provide necessary information before returning the product.





Dry out pump inside before returning the product if it was used to pump condensable gases.

For safety reasons, replace remaining gases with N<sub>2</sub> (nitrogen) completely and seal inlet and outlet port with blank off caps prior to returning the pump for repair/overhaul service if the pump was used to pump toxic gases.

## 1.2 Types of Warning Label

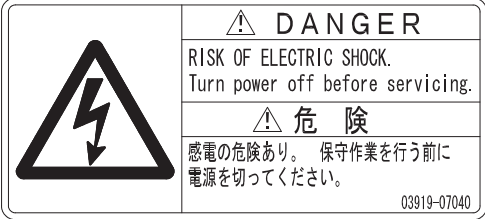
The following warning labels are attached to the main body of the dry vacuum pump to provoke cautions on use. The warning label positions are shown on the next page.

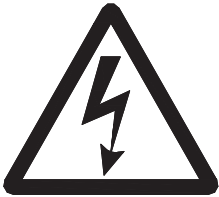
List of Warning Labels on the Dry Vacuum Pump

Warning Label A	Warning Label B	Warning Label D
		
<p data-bbox="331 875 544 904">Warning Label C</p> 		

### 1.3 Warning Label Positions

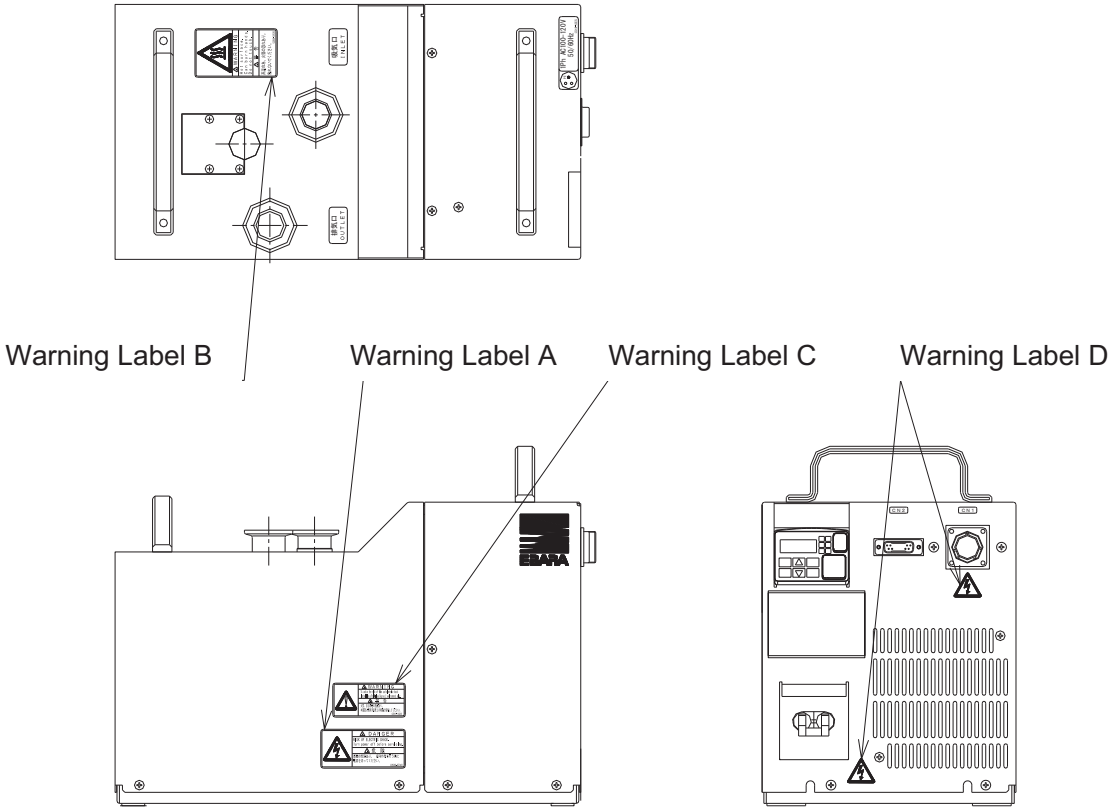

## 2. PRODUCT CONFIRMATION

This dry vacuum pump is delivered after it is strictly inspected and packed. When the user receives the package, open it and confirm the following points.

- \* Check if its components parts are all included.
- \* Check if the pump specifications comply with those of your orders.
- \* Check if any damage has not occurred during transportation.

If any fault is found, please inform one of our offices listed in the back at once.

- \* Regarding pump accessories, check them according to the packing list separately dispatched.

<Storage of the Pump>

- \* In case the pump is not installed immediately after it is received, store it in a clean environment in the following conditions:

Temperature	5 to 40 deg. C
Humidity	80 % or less (Condensation must not exist)

- \* Don't pile packed pumps and don't lay each pump on its side in any case

### CONFIRMATION

Don't pile packed pumps and don't lay each pump on its side in any case, otherwise the damage may be caused to the pumps.

### 3. PRODUCT OVERVIEW

Pumps basically consist of a pumping mechanism; electrical parts are mounted on the base and covered with package.

#### 3.1 Pump Body

- \* A pair of hybrid roots rotors synchronously rotates, keeping a given clearance, and transfers the gas from inlet port to outlet port.
- \* Gears are installed on the other side of rotors and lubricated with oil.
- \* This series adopts synchronized motor.
- \* They are heated up by the compressed gas, the friction at the bearing and at the seals makes pump temperature high, under which the pump is cooled with cooling fan.
- \* To prevent condensation in the pump when condensable gas is pumped, adopt the gas ballast mechanism.  
(The gas ballast mechanism is an option.)
- \* Silencer is built in to reduce exhaust noise.

#### 3.2 Electrical equipment

- \* The pump package has built-in circuit protector, noise filter, and inverter.
- \* Electrical component varies depending on power supply. Choose appropriate model according to facility set up.  
(See Product Specification section next page for power supply and pump model.)

#### 3.3 Gas ballast mechanism (Option)

Condensable gases (water vapor, solvent mixed gas) pumped may condense and become liquid in the pump if it exceeds its saturated vapor pressure. Gas ballast mechanism prevents condensation by introducing air or nitrogen which reduces the partial pressure of the pumped gases. Condensable gases are exhausted from outlet port without condensation by introducing ballast gas.

(Maximum water vapor pump rate : 250g/h)

It is recommended to use the following gas ballast mechanism when pumping condensable gases.

- ⇒Pumping non flammable vapor, condensable solvent : Atmospheric (air) ballast
- ⇒Pumping flammable solvent and gas, condensable solvent : N<sub>2</sub> ballast

### 3.4 Product Specifications

Specification Table

Item		Model	EV-A03		
			EV-A03-1 (Single Phase 100V)	EV-A03-2 (Single Phase 200V)	EV-A03-3 (Three Phase 200V)
Max. Pumping Speed [50/60 Hz]		250 L/min			
Ultimate Pressure		1.0 Pa	Note1) w/ gas ballast OFF		
		10 Pa	Note1) w/ gas ballast ON		
N2 Gas ballast Note2) N2 supply pressure (Gauge press.) Regulator set pressure		0.01 – 0.05 MPa			
Max. Inlet Pressure		Atmospheric pressure			
Max. Back Pressure (Gauge press.)		3 kPa or less			
Max. water vapor pumping rate		Note3) 250 g/h			
Motor Rated Power		0.4 kW			
Operating current [50/60 Hz] (Primary current) Note4)		5.0 – 7.5 A	3.2 – 4.0 A	1.5 – 2.3 A	
Flange Size	Inlet	NW25 (Quick Flange)			
	Outlet	NW25 (Quick Flange)			
Publication Oil		0.12 liter (Synthetic oil)			
Weight		Approx. 23 kg			
Size		210W x 385L x 250H			
Operating condition	Atmosphere temperature	15 to 30 deg. C			
	Relative Humidity	20 to 80% (condensation must not exist)			
Pollution Degree		Pollution Degree 2			
Maximum Operating Altitude		2000m			
<b>Utility Requirements</b>					
Power Supply	Voltage [50/60 Hz]	100-120 V	200-240 V	200-240 V	
	Tolerable voltage fluctuation Note5)	±10%	Note6) ±10%(Max 250V)		
	Capacity	0.8 kVA			
Note7) Safety standard		NRTL (UL61010-1) CE Marking			

- 
- Note 1) The gas ballast mechanism is an option.
  - Note 2) N2 supply pressure for N2 gas ballast mechanism
  - Note 3) Maximum water vapor pumping rate with gas ballast valve fully opened.
  - Note 4) Actual value may not be in the range depending on facility.
  - Note 5) This describes tolerable voltage range, and is not steady voltage.
  - Note 6) Do not use this product with over 250V even it is within the tolerable range.
  - Note 7) For more details about overseas safety standard, contact one of our sales offices listed in the back.

### 3.5 External View

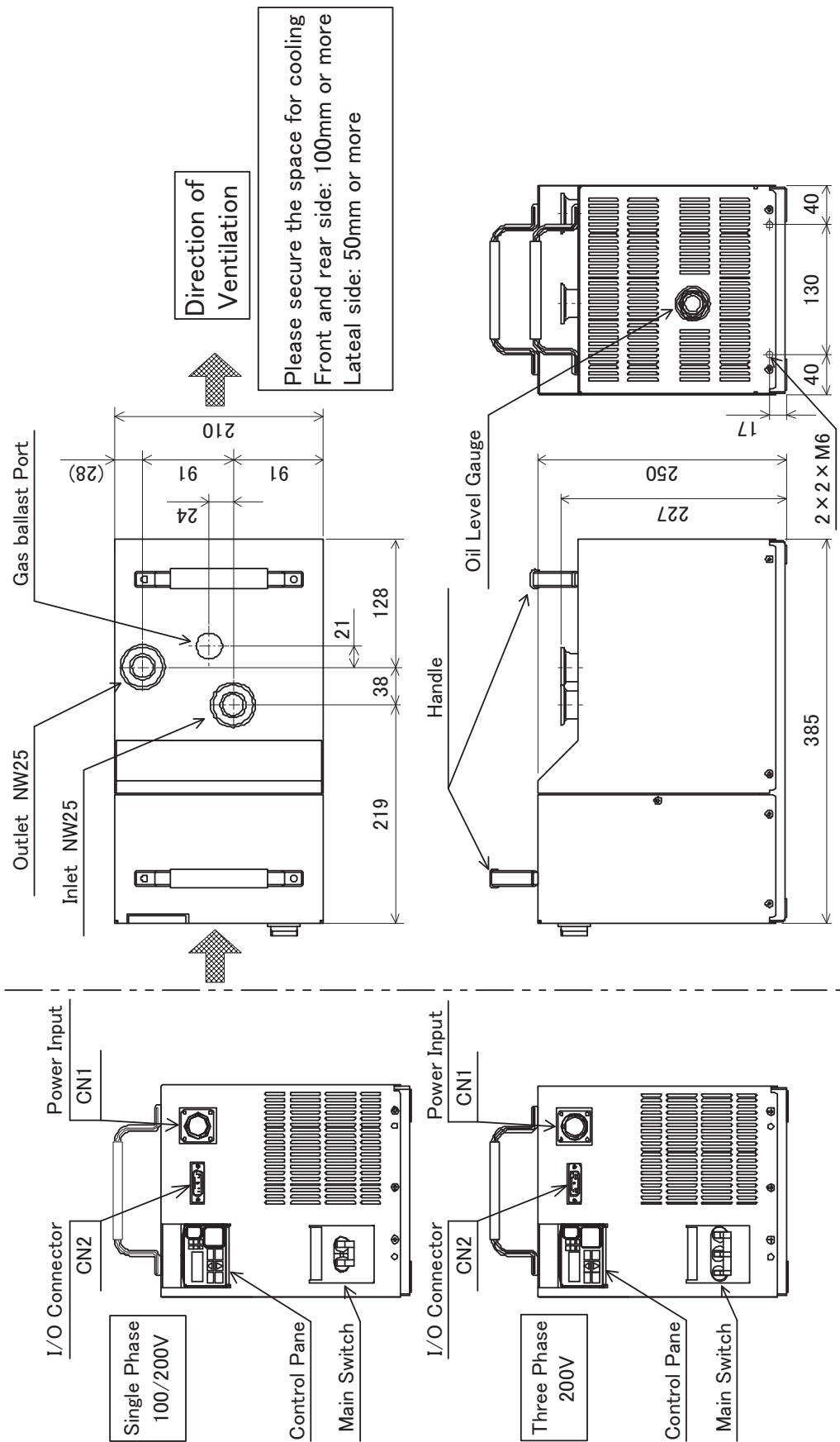

### 3.6 Pumping Performance

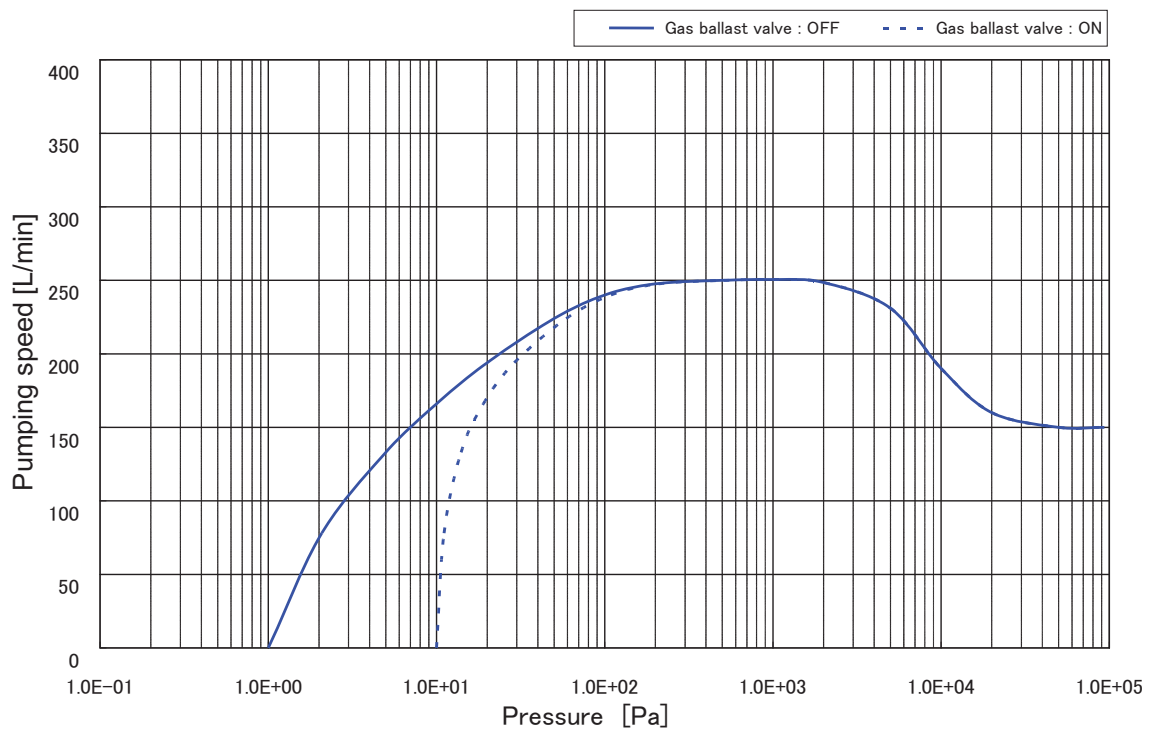

Note) The gas ballast mechanism is an option.

## 4. INSTALLATION OF THE PUMP

The pumping performance of the dry vacuum pump is affected by the opening diameter and length of the inlet / outlet pipe and the performance of the installed peripheral units.

Moreover, when corrosive gas is pumped, proper maintenance is required for each use to operate the pump normally for a long period. When the pump is installed, valves and pipes are recommended to be installed beforehand to secure higher maintenance efficiency.

Adopt pipes and sealing parts in consideration of corrosion resistance.

### 4.1 Installation

#### 4.1.1 Installation

- \* The pump is a heavy material (Approx.23 kg). To facilitate the maintenance work, install the pump on the floor.
- \* When moving pump on the uneven place, please put the pump on the carriage.

### CAUTION

Do not step on the pump, otherwise falling or turnover may be caused. Do not place anything on the pump as it may damage the product.

Do not lift the pump by your self. Lift the pump by hand with two (2) persons. Do not use sling or the like to lift the pump as the handles are not designed to be used with slings.

### CONFIRMATION

Keep space, 100mm or more at front and rear side, 50mm or more at lateral side, to secure good ventilation for cooling. Bad ventilation can cause pump overheat which results in unpredicted pump failure.

Do not place the device which could be heat source at the front of pump, and consider that air ventilation temperature around pump is kept at 15 to 30 degrees C. High-temperature ventilation heats up pump and causes pump failure.

- \* Install the pump indoors.
- \* Install the pump inlet and inlet port facing up on a solid and level surface of the floor or frame.
- \* Install the pump where the base is stable enough to load and vibration.
- \* Allow a proper space around the pump so that the pump may be installed and maintained smoothly.
- \* Be careful to make the temperature from 15 to 30 deg. C and to make the humidity from 20 to 80% (condensation must not exist) around the pump while it is operating, especially in closed place, because that may cause dew condensation inside the pump.
- \* Keep space, 100mm or more at front and rear side, 50mm or more at lateral side, to secure good ventilation for cooling.
- \* Set the pump up in the place of above sea level 2000m or less.
- \* Please use by "Pollution degree 2".

Avoid installing the pump in the following places:

- a) Outdoors, a place that may be splashed with water, and a place of extremely high humidity. (A place of 80% or higher humidity is not proper.)
- b) A place where a toxic gas such as acid and alkali gases exists.
- c) A place where an explosive or combustible gas exists.
- d) A dusty place.
  - \* Do not install the pump in the environment where the pump may be exposed to rain, snow, ice and dust.

- \*Please fix the pump with appropriate bracket. (Fig.4.1, Fig4.2)  
(The bracket is an option.)
- \* Use M8 bolt and nut for pump fixing.

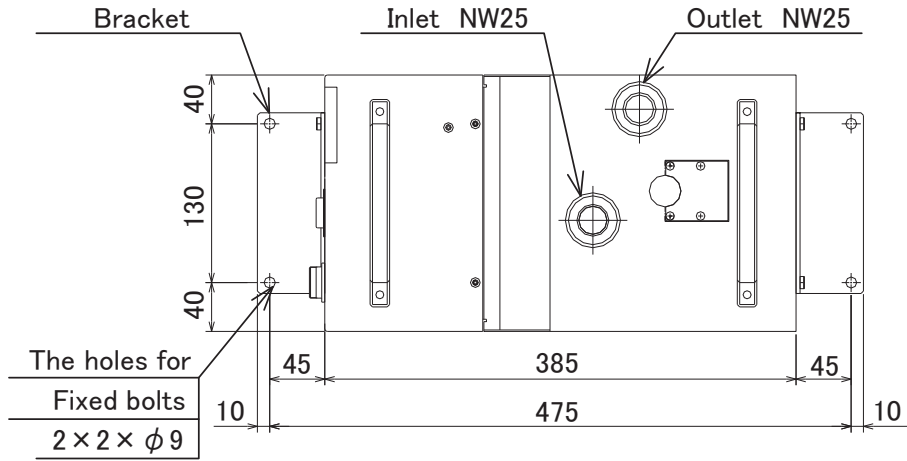

Fig.4.1 Pump fixation position

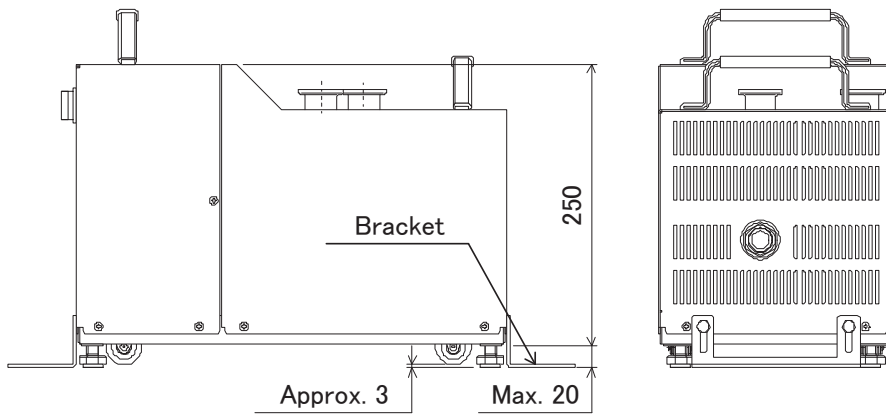

Fig.4.2 How to fix the pump with casters and adjusters

## 4.2 Piping

### 4.2.1 Vacuum and outlet piping

Connect a vacuum pipe and an outlet pipe to the inlet port and the outlet port, respectively. The inlet port of the dry pump is an NW25 quick flange, while the inlet port of this pump is an NW25 quick flange. Perform piping or make connections to different parts by using these flanges.

### WARNING

Because the temperatures of the inlet and outlet pipes of the pump become high, arrange them so that they may not come in contact with the human body and combustible materials.

### CAUTION

Adopt high corrosion-resistant materials for pipes and parts used on both inlet port and outlet port sides.

- \* Use clean pipes without any foreign material for piping.
- \* Don't install a heavy material directly at the inlet port and the outlet port; otherwise a leak or damage will be caused to the connecting portions.
- \* It is recommended to use a stainless flexible joint between the pump and a pipe.
- \* Take care adhering of either any dust or foreign material to the flange seal surface. And take care not to put the scar on the flange face.
- \* To keep the exhausted system in a vacuum condition, install a vacuum shut-off valve between the pump and the exhausted system.
- \* If there is a possibility that dust may be absorbed, install a proper scale trap or filter at the fore line of the pump.
- \* Take it into consideration to allow enough conductance for piping and exhaust gas processing facilities so that the pressure on the outlet port side (back pressure) of this pump may be 3 kPa or less.

### 4.3 Electric Wiring

This product is not equipped with earth leakage breaker (ELB) and emergency off switch (EMO). Follow the local regulations when installing this product. Use adequate earth leakage breaker which corresponds to the specifications below if necessary.

※Use this pump with protective equipment pursuant to “About Safety Standard of The Pump”, in P.7, when operate it according to the oversea safety standard.

Table 4.1 Power supply and capacity of breaker

		EV-A03		
		Single phase		3 phase
Note 1) Type		EV-A03-1	EV-A03-2	EV-A03-3
Power supply [50/60 Hz]		100-120 V	Note 2) 200-240 V	200-240 V
Earth leakage breaker	Rated Voltage	125 V or more	250 V	250 V
	Rated Current	15 A	10 A	5 A
	Rated Sensitivity Current	30 mA		

Note 1) The pump model is different depending on the power supply specification.

Note 2) Use this pump pursuant to the voltage range stated in P.7, “About Safety Standard of The Pump”, when operate it according to the oversea safety standard.

#### **DANGER**

Turn off the main switch on the pump and disconnect power cable before servicing. Do not supply power before completion of service work.

#### **WARNING**

Wiring work must be done by qualified workers.

For US installations, the EV-A03 dry pump should be installed downstream of a UL Listed Branch Rated Circuit Breaker (Listed to UL 489) or a set of UL Listed Branch Rated fuses.

For CE installations, the EV-A03 dry pump should be installed downstream of a CE Approved Circuit Breaker (Approved to IEC 60947-2) or a set of CE Approved Branch Rated fuses (Approved to IEC 60269.)

Connections of the dry pumps to a facility wiring system or host system must be in accordance with all applicable wiring practices described in the National Electric Code (for US Installations only) or all applicable facility wiring practices for the European Union (for EU installations only).

## 4.3.1 Power wiring (Connector symbol: CN1, power supply)

 **WARNING**

Be sure to perform grounding, otherwise an electric shock may be caused by electric leakage.

Use the wiring materials that correspond to the pump power.

Table 4.2 Wiring material

Type	EV-A03-1	EV-A03-2	EV-A03-3
Applicable wire size	AWG#12 (3.5 mm <sup>2</sup> )	AWG#14 (2.0 mm <sup>2</sup> )	
Number of wicks	3		4

A. How to connect wires; Single phase 100V type. [EV-A03-1]

For pin connections of the power connector, refer to Fig.4.3, Table 4.3, and Table 4.4.

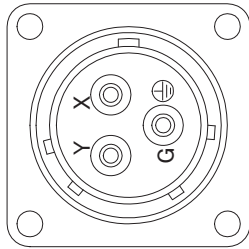

Table 4.3 CN1 Receptacle Pin Assign

Pin No.	Phase
X	L : Load
Y	N : Neutral (Ground side)
G	Grounding

Fig.4.3 CN1 Pump-side Receptacle

Table 4.4 CN1 Receptacle Specification

Receptacle model	NET-243RM
Connector maker	Nanaboshi Electric Mfg. Co.,Ltd.
Applicable plug (Note 1)	NET-243PF
Applicable wire size	AWG #12 (3.5mm <sup>2</sup> )

Note 1) Applicable plug is standard accessory

Note 2) Do not use cord reel for power supply, as it may cause the case where pump dose not start due to voltage drop.

B. How to connect wires; Single phase and three phase 200Vtype. [EV-A03-2,3]

For pin connections of the power connector, refer to Fig.4.4, Table 4.5, and Table 4.6.

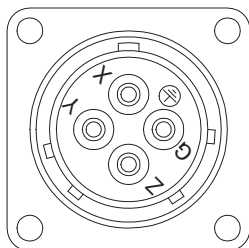

Table 4.5 CN1 Receptacle Pin Assign

Pin No.	Phase	
	Single phase 200V EV-A03-2	Three phase 200V EV-A03-3
X	L : Load	R
Y	N : Neutral (Ground side)	S
Z	(Not connected)	T
G	Grounding	

Fig.4.4 CN1 Pump-side Receptacle

Table 4.6 CN1 Receptacle Specification

Receptacle model	NET-244RM
Connector maker	Nanaboshi Electric Mfg. Co.,Ltd.
Applicable plug (Note)	NET-244PF
Applicable wire size	AWG #14 (2.0mm <sup>2</sup> )

Note) Applicable plug is standard accessory

4.3.2 Control wiring (Connector symbol: I/O connector CN2)

Please install the driving connector in the I/O connector (CN2) when it will operate under “Direct power input”.

To perform remote operation or monitoring, perform wiring to the I/O connector CN2.  
For pin connections, refer to Fig.4.5, 4.6 and Table4.7.

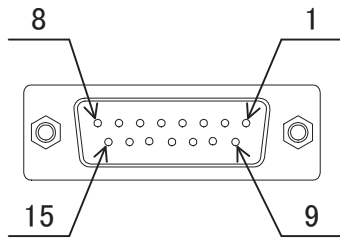

Fig.4.5 CN2 Pump-side Receptacle

Table 4.7 CN2 Receptacle Specification

D-sub model	DA-15SF-N
Fixed screw	(D20418-J3F) M2.6
Connector maker	Japan Aviation Electronics Ind., Ltd.
Applicable plug (Note)	DA-15PF-N
Clamp hood (Note)	DA-C8-J10-F1-1
Applicable wire size	AWG #24-20 (0.2-0.5mm <sup>2</sup> )

Note) Applicable plug and clump hood are not attached.  
Please prepare by the equipment side.

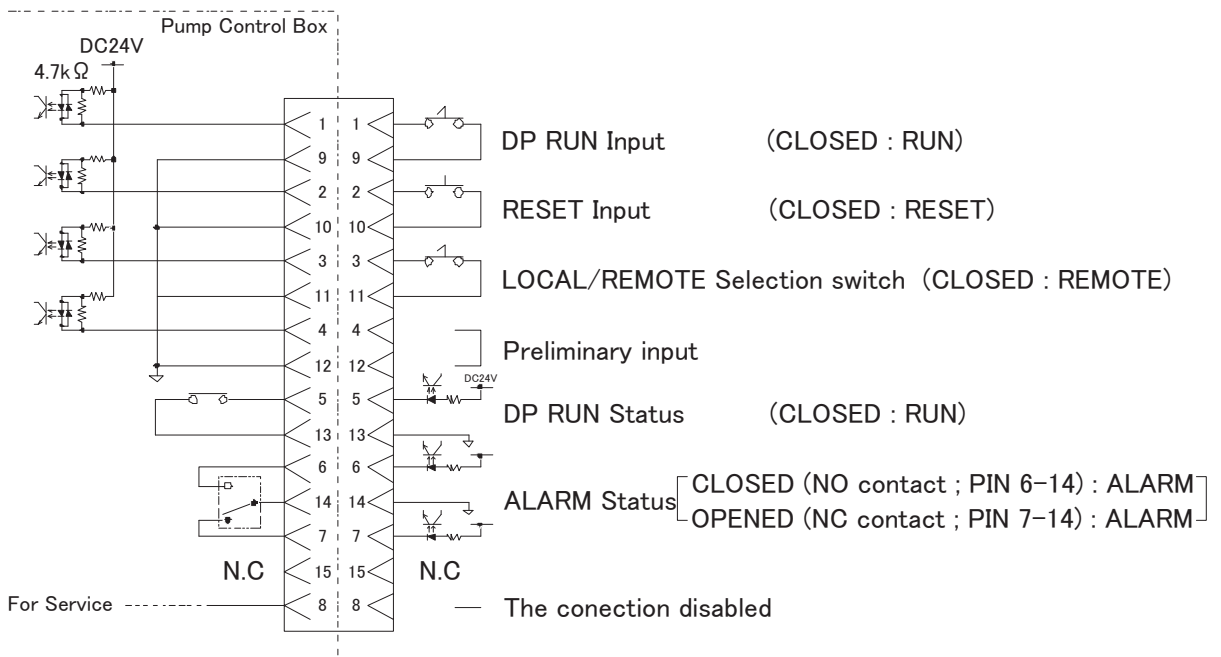

Fig.4.6 I/O connector CN2 D-sub Connector Pin connections

**CONFIRMATION**

For Input signals (Pin No. 1-9, 2-10, 3-11, 4-12), apply a voltage of 24V DC on the pump controller side. Don't apply a voltage on the equipment side; otherwise the controller may go wrong.

The output signal (pin No. 5-13) is no-voltage relay contact outputs. The contact capacity is AC230V/0.2A and DC30V/0.3A.

The output signal (pin No. 6, 7-14) is 1c no-voltage relay contact outputs. The contact capacity is AC230V/0.2A and DC30V/0.3A.

Please make the RESET Input signal (pin No. 2-10) "Closed" for 0.1 seconds or more.

When I/O connector (CN2) is used for remote control and monitoring, use shielded cable to eliminate EMC noise. Connect shield end to connector housing.

## 5. OPERATION PANEL

There are four different modes to run and stop the pump, “Direct power input”, “Operation by operation-panel”, “Operation by external signal” and “Operation by the handheld controller”.

If “Direct power input” is selected, set driving connector, that is standard accessory, onto “I/O connector (CN2)”.

### 5.1 Operation Panel

Running status can be checked by LED display on operation-panel.

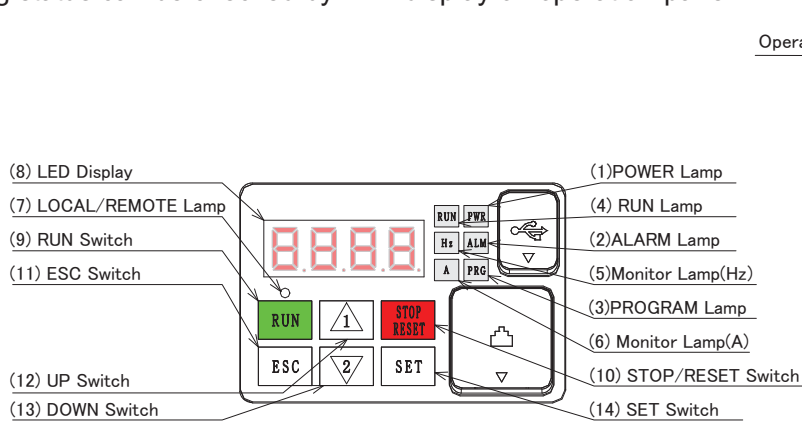

Fig. 5.1 Operation panel

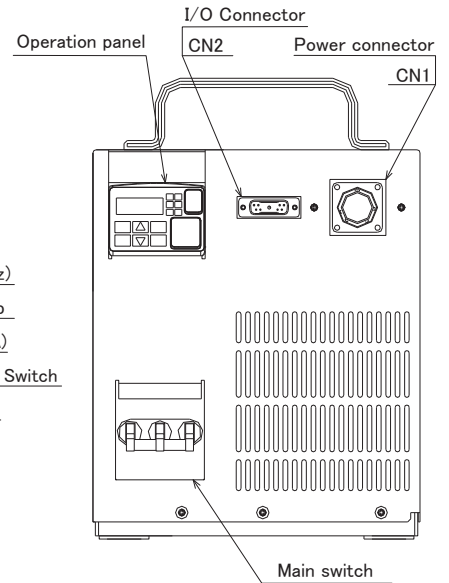

Fig. 5.2 Pump operation side

Table. 5.1 Explanation of operation panel.

No.	Name	Subject
(1)	POWER Lamp	Lights up when power is supplied
(2)	ALARM Lamp	Lights up in red when inverter trips
(3)	PROGRAM Lamp	Does not light up
(4)	RUN Lamp	Lights up when running
(5)	MONITOR Lamp(Hz)	Lights up when LED display indicates frequency
(6)	MONITOR Lamp(A)	Lights up when LED display indicates current
(7)	LOCAL/REMOTE Lamp	Lights up when running in local mode(light out in remote mode)
(8)	LED Indicator	Indicate run time, rotation speed and inverter 2ndary side current
(9)	RUN switch	Starts up the pump (Only in local mode)
(10)	STOP/REST Switch	Stops the pump, and reset
(11)	ESC Switch	Switches between LED indicator and group code
(12)	Up Switch	Operates data indicator
(13)	Down Switch	
(14)	SET Switch	Switches between indicated data and content

## 5.2 How to switch LED display

Pump conditions and control settings can be checked on the LED display. Display shows 4 digits and the first letter from the left is group code.

### 1) How to switch display

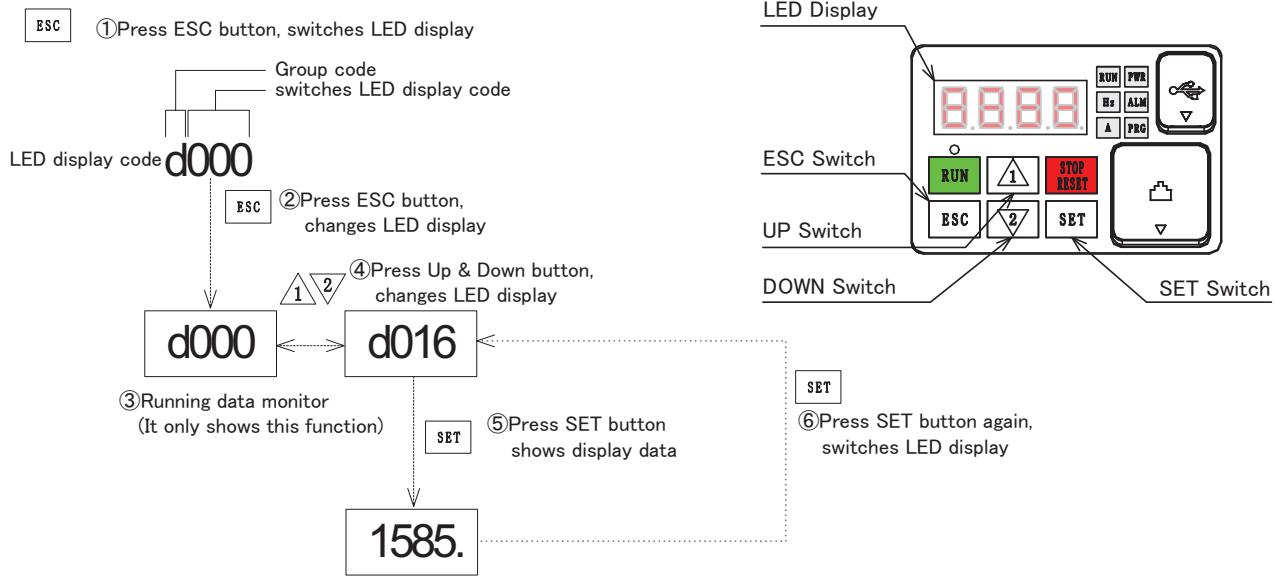

Note) When the pump turns on, LED display shows run hour.

### 2) Group Code

Group Code	LED display	How to control
d000	Monitors run data	Only this group code(d) can be switched
b000	Inverter setting	This group code (b) can not be controlled

### 3) Contents of LED display

LED display code	Display data	Unit	Note
d001	Run frequency	Hz	Monitor lamp (Hz) lights up when it is displayed.
d002	Secondary current	A	Monitor lamp (A) lights up when it is displayed.
d016	Total run hour	hrs	Data range
			Content
d017	Total electrified hour	hrs	*1 0.0 – 9999.
			*2 1000 – 9999
			*3 100 – 999
d080	Error count monitor	Time	*4 0. – 9999.
			*5 1000 - 6553
d081 – d086	Error monitor	-	Last 6 errors available. See P.46 how to use LED monitor section - indicated when there is no error

## &lt;Example of LED indication&gt;

LED Display	Data range	Example	Run hour / time
Total run hour Total electrified hour	*1 0.0 – 9999.	3333.	3,333 hour
	*2 1000 – 9999	3333	33,330 hour
	*3 「100 - 「999	「333	333,000 hour
Error count monitor	*4 0. – 9999.	3333.	3,333 time
	*5 1000 - 6553	3333	33,330 time

## 6. OPERATION AND STOP

### 6.1 Preparations for Operation

- 1) Check if electric wiring is properly performed.
- 2) Check if the inlet pipe and the outlet pipe are securely connected. When a valve is installed on the outlet side, open the valve securely before starting the pump.
- 3) Make sure good ventilation for the pump is secured.

### 6.2 Operation and Stop

#### **WARNING**

Pump remains hot during and/or after operation. Avoid direct skin contact otherwise it may cause burn. Keep combustible materials away from the product. Do not attempt to service the product when it is hot.

Do not remove packaging covers during operation.

#### **CONFIRMATION**

Use gas ballast mechanism and introduce ballast gas into the pump during operation when pumping condensable gases.

- \* Close the cut-off valve on the inlet port side of the pump when needed.  
(To keep the vacuum system in vacuum, it is necessary to install shut-off valve between the system and the pump. Close this valve before the pump stops.)
- \* When condensable gas such as water vapor has been pumped, please keep the pump running opening the inlet port for about one hour after pump operation.  
Corrosion in the pump can be prevented by removing the residual with dry air.  
As the pumped gas quantity is larger, perform the dry air pumping for a longer time.
- \* If there is an open/close valve on the outlet port side of the pump, close this valve.

#### 6.2.1 Pump operation with driving connector (Direct power input : Driving connector is a standard accessory)

<Please install the driving connector at the I/O connector (CN2).>

##### A. Driving by primary side power supply ON/OFF

###### START

- 1) Switch on the MAIN POWER switch (CP) on the pump.
- 2) Supply power to the pump. At the time, the pump will be started.  
(The RUN Lamp on the operation panel will come on.)
- 3) Make sure that abnormality (unusual noise and/or vibration) is not found after the pump starts.

###### STOP

- 1) When the power supply is turned off, the pump will be stopped.

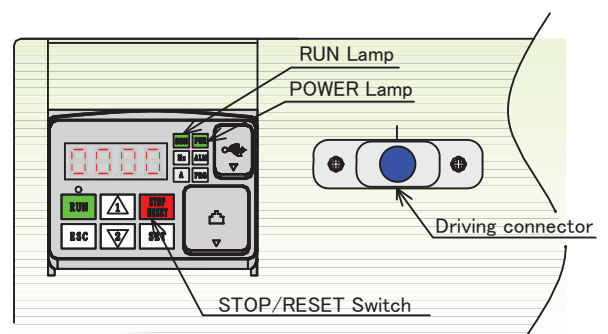

**B. Driving by MAIN POWER Switch ON/OFF****START**

- 1) Supply power to the pump.
- 2) Turn on the MAIN POWER switch on the pump. At the time, the pump will be started.  
(The POWER Lamp, RUN Lamp on the operation panel will come on.)
- 3) Make sure that abnormality (unusual noise and/or vibration) is not found after the pump starts.

**STOP**

- 1) When the MAIN POWER switch (CP) is turned off, the pump will be stopped.

**CONFIRMATION**

Pump starts operation as soon as power is supplied if pump run command is present. Take safety precautions and make sure that the pump inlet and outlet port are plumbed properly before supplying power.

Pump stops in emergency off state if STOP/RESET switch on the controller is pressed during pump operation with driving connector under direct power input. To restart the pump, turn power off (wait until LED light goes off) then turn it back on.

**6.2.2 Operation by operation-panel.**

< Please confirm the driving connector is not placed to I/O connector (CN2) >

**START**

- 1) Supply power to the pump.  
Turn on the MAIN POWER switch on the pump.  
(The POWER, LOCAL/REMOTE lamp on the operation panel will come on.)
- 2) Press the RUN switch on the operation panel.  
At the time the pump will be started.  
(The RUN Lamp, on the operation panel will come on.)
- 3) Make sure that abnormality (unusual noise and/or vibr

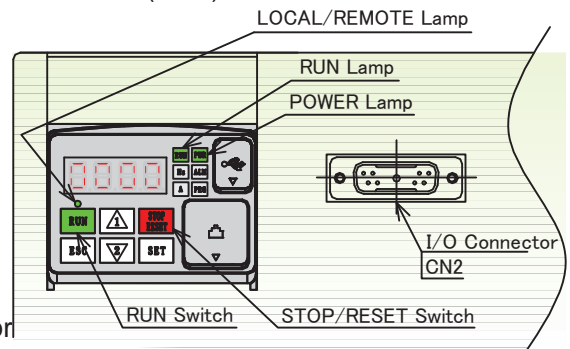
**STOP**

- 1) Press the STOP/RESET switch on the operation panel, the pump will be stopped.  
(The RUN Lamp on the operation panel will go out.)

### 6.2.3 Operation by external signal

<Please perform wiring for the control to I/O connector (CN2) >

Applicable plug and housing are not standard accessory. Prepare them separately.  
(Please refer to the chart of clause 4.3.2 Control wiring in P.28 for details of wiring for the control.)

#### START

- 1) Supply power to the pump.  
Turn on the MAIN POWER switch on the pump.  
(The POWER, LOCAL/REMOTE Lamp on the operation panel will come on.)
- 2) Input the LOCAL/REMOTE Selection signal from the I/O connector (CN2). (Pin No.3-11)  
(The LOCAL/REMOTE Lamp on the operation panel will go out)
- 3) Input the DP RUN Input signal from the I/O connector (CN2). (Pin No.1-9)
- 4) The pump will be started and RUN Lamp on the operation panel will come on.  
At the time, DP RUN Status signal will be put into a make state. (Pin No. 13-6)
- 5) Make sure that abnormality (unusual noise and/or vibration) is not found after the pump starts.

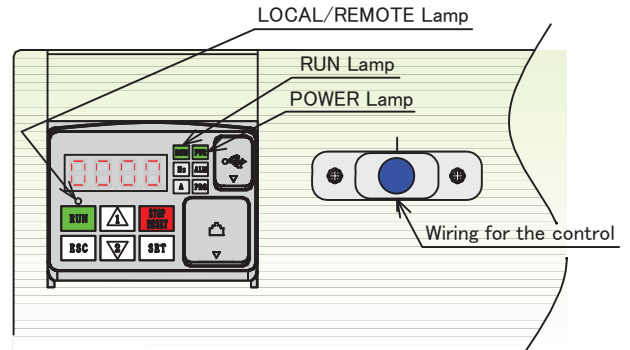

#### STOP

- 1) Put the DP RUN Input signal from the I/O connector (CN2) into an open state.  
(Pin No. 1-9)  
The pump will be stopped and the RUN Lamp on the operation panel will go out.  
At the time, DP RUN Status signal will be put into an open state. (Pin No. 13-6)

## CONFIRMATION

Pump stops in emergency off state if STOP/RESET switch on the controller is pressed during pump operation under remote control. To restart the pump, deactivate pump run command (pin No. 1-9) then apply the command again or press STOP/RESET button.

In the states that "LOCAL/REMOTE Selection Switch" in the I/O connector (CN2) is open – means Pin No.3-11 is open circuit –, external signal mode is not available. In this case, handling by operation-panel is required.

#### 6-2-4. Operation by the handheld controller

Note) The handheld controller is an option.

<Please connect the handheld controller attachment cable with the I/O connector (CN2) >

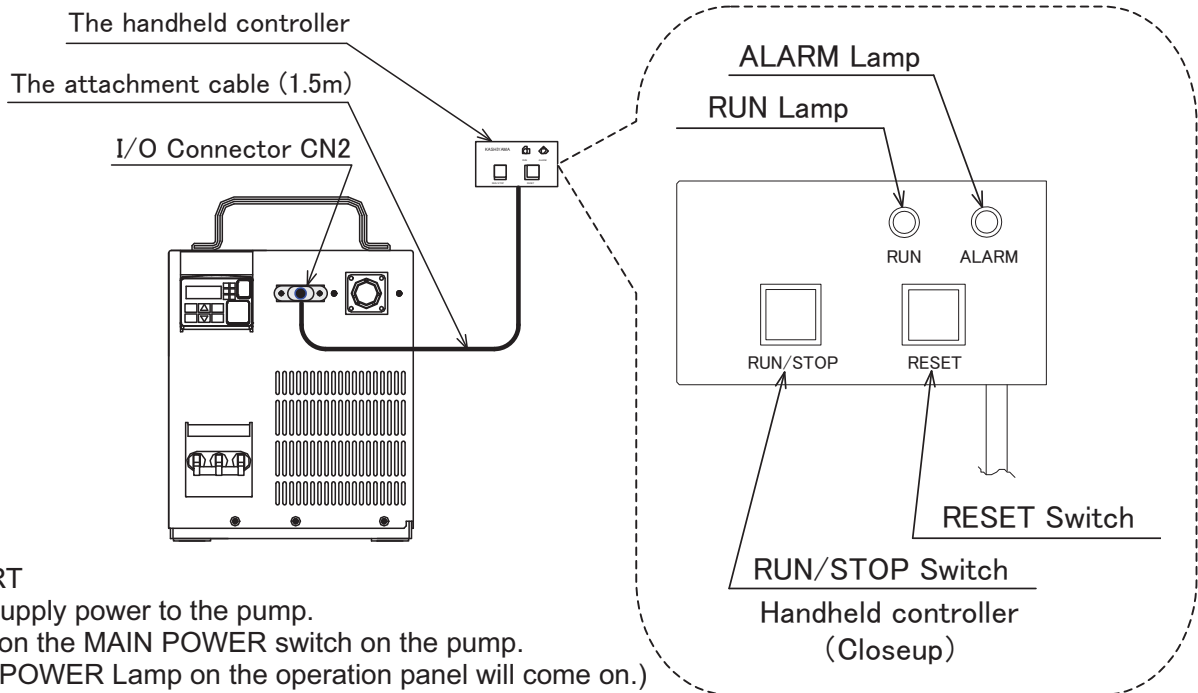

#### START

- 1) Supply power to the pump.  
Turn on the MAIN POWER switch on the pump.  
(The POWER Lamp on the operation panel will come on.)
- 2) Press the RUN/STOP switch on the handheld controller.  
The pump will be started and the RUN Lamp on the handheld controller will come on.  
(The RUN Lamp on the operation panel will come on.)
- 3) Make sure that abnormality (unusual noise and/or vibration) is not found after the pump starts.

#### STOP

- 1) Press the RUN/STOP switch on the handheld controller.  
The pump operation will stop and the RUN Lamp on the handheld controller will go out.

### CONFIRMATION

Do not detach the handheld controller during the operation. The pump stops when the handheld controller is removed.

## 6.3 About the Gas Ballast Mechanism

Note) The gas ballast mechanism is an option

### IMPORTANT

\*Condensable gas (water vapor, solvent mixed gas) can be prevented from being condensed inside the pump by making the gas ballast valve "Open". Use gas ballast valve whenever you use such gas, as it can elongate pump's life.

It is effective to keep the pump running about one hour with the valve open after pumping out condensable gas like water vapor.

(Check appropriate running hours with the valve open as it varies depending on usage and condition)

There are two types of gas ballast system. One is for air introduction and another one is for N<sub>2</sub> introduction. Select either one of the system by the gas you use. If you pump solvent or the like, contact one of our sales offices listed in the back regardless of its kind and amount. When you pump flammable chemical, always introduce N<sub>2</sub> through gas ballast system.

After large amount of condensable gas is pumped, such amount as liquidate even if the gas ballast valve is open, run the pump around one hour with the pump inlet and valve open.

(Check appropriate running hours with the valve open as it varies depending on usage and condition)

\*The performance of gas ballast system will be different depending on the pump operating temperature, the kind of condensable gas and its amount.

\*Turn off the gas ballast valve when you do not use condensable gas.

### CONFIRMATION

Always use gas ballast mechanism (optional) when pumping condensable gases.

When using gas ballast valve, while the beginning operation of which the pump is still cold, "gas ballast capability" cannot be fully performed. If it is necessary to exhaust water vapor and other condensable gases, warm-up the pump enough (more than 1 hour after running) and use gas ballast mechanism. While the pump is still cold, "gas ballast capability" cannot fully perform and condensable gas (eg, solvent gas) condenses inside the pump of which may lead to the pump stop.

When the pump stops and the gas ballast valve still remains "open" state, air is introduced from the gas ballast valve into the pump. This cannot keep vacuum condition of the pump. If it is necessary to keep vacuum of the pump and/or equipment, attach shut off valve at the top of the pump inlet to hold vacuum condition and shut it off before the pump is stopped.

Maximum supply pressure for N<sub>2</sub> gas ballast is 0.05MPa.

Do not over pressurize as it may damage the pump.

Air gas ballast mechanism has a built in filter to protect the pump from foreign materials in the air. When pump is used in dusty environment the filter may get clogged and reduce ballast gas flow into the pump which will cause a failure to prevent condensation in the pump. Install the pump in clean environment.

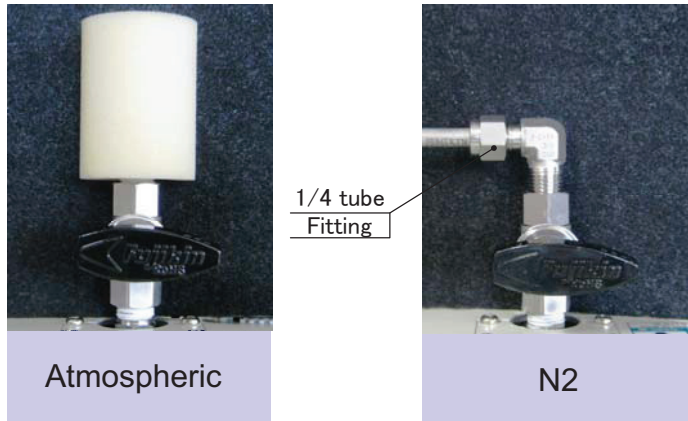

Photo 6.1 Gas ballast specifications

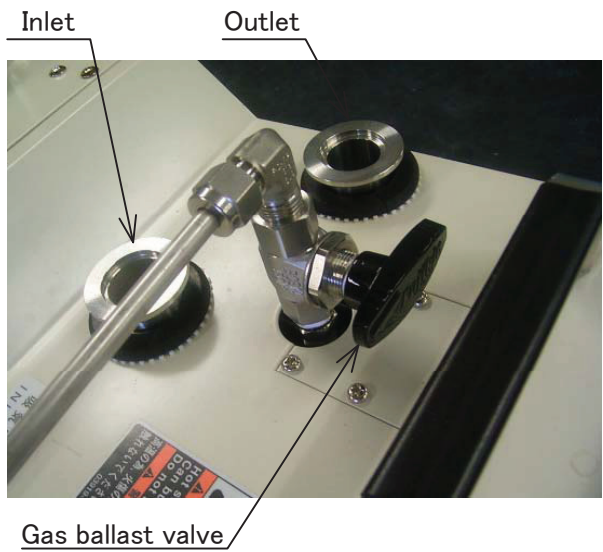

Photo 6.2 The pump of which gas ballast valve is installed

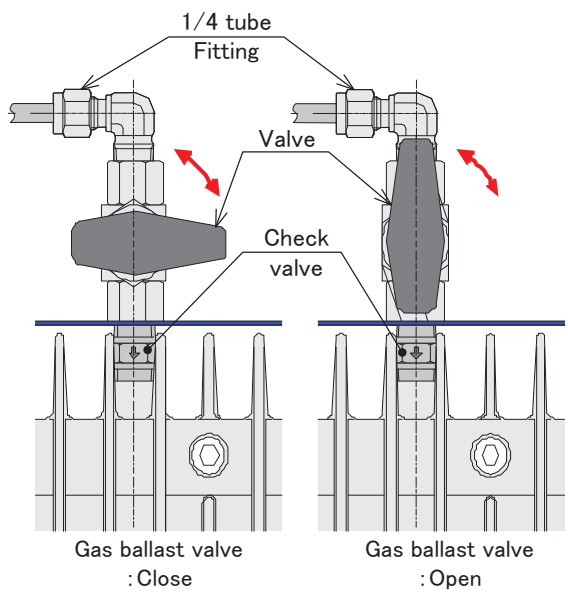

Fig 6.1 How to open-and-close the gas ballast valve

## 7. MAINTENANCE

### 7.1 Routine Maintenance

Check pump condition such as power supply, ultimate pressure and back pressure etc. regularly and verify that the pump is used under normal operating condition. Refer to P.45 (8. Trouble shooting) section for trouble shooting if there is any error message and/or alarm lamp lit on the control panel.

Lubricant oil refill is required if the oil level is below lower limit on level gauge. See P.41 (7.3 Lubricant oil) section for details.

#### DANGER

Turn off the main switch on the pump and disconnect power cable before servicing. Do not supply power before completion of service work.

#### WARNING

Pump remains hot during and/or after operation. Avoid direct skin contact otherwise it may cause burn. Keep combustible materials away from the product. Do not attempt to service the product when it is hot.

Do not remove packaging covers during operation.

When pump error arises, press STOP/RESET switch on the controller or apply reset command at CN2 I/O connector (Pin No.2-10) after solving the problem. The error will be reset.

#### CAUTION

Deactivate pump run command signal before servicing if pump error arises during the operation under remote control.

When pump abnormal condition arises other than error message and/or alarm lamp on the controller, refer to P.45 (8. Trouble shooting) section for trouble shooting.

## 7.2 Inlet and outlet piping

Take the following precautions when performing the piping maintenance.

- (1) Always turn off power supply.
- (2) Dry the piping completely before installation if cleaning performed.

### **WARNING**

Pump remains hot during and/or after operation. Avoid direct skin contact otherwise it may cause burn. Keep combustible materials away from the product. Do not attempt to service the product when it is hot.

Do not remove packaging covers during operation.

Perform leak check after piping maintenance. Apply pressure from exhaust piping and pressurize up to 0.05 MPa for pressure leak check.

## 7.3 Lubricant oil

Check oil level regularly. Oil level gauge is located at rear end of the pump. See diagram 7.1 Oil level gauge position below.

The level may be lower than lower limit during the operation which is normal. Stop the pump and wait until the level becomes stable, then check the level.

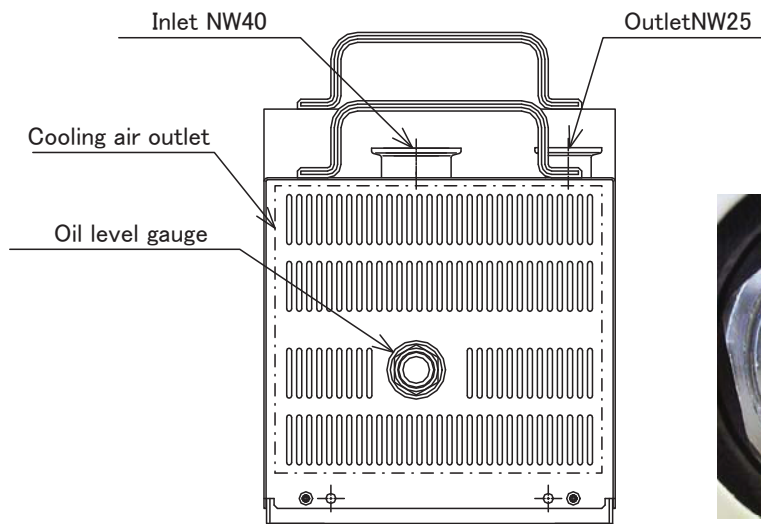

Fig. 7.1 Oil level gauge position

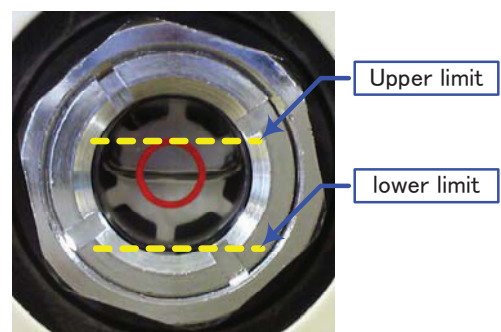

Photo 7.1 Oil level

Oil refill is required when the level is below lower limit. Refill the oil following the procedure below.

- (1) Stop the pump. Remove the packaging covers.
- (2) Wait until pump internal pressure becomes atmospheric and cool enough. Then remove the filler plug.
- (3) Refill oil as checking the level up to the center of red circle on the gauge.
- (4) Clean the o-ring and place it on the plug, then put it back and tighten securely.
- (5) Perform leak check after the oil refill.

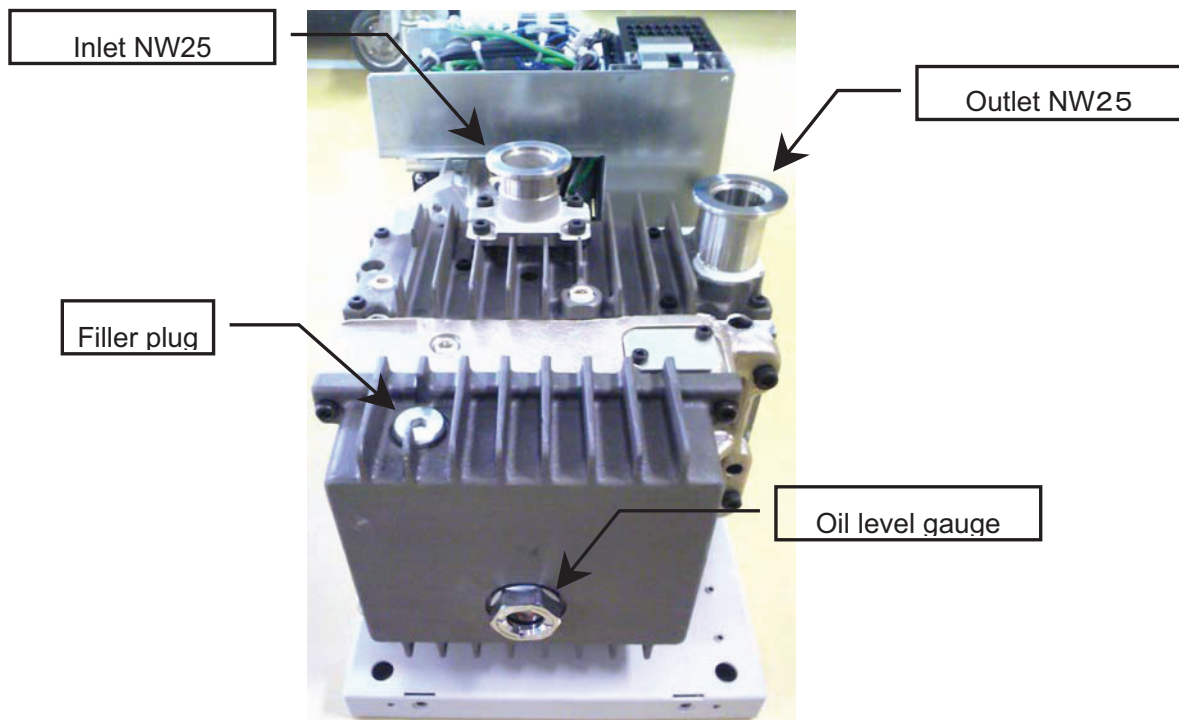

Photo 7.2 Filler plug and oil level gauge position

### CAUTION

Use lubricant oil specified on P.18 (3.4. Product specification) section.

Do not overfill more than upper limit as it may damage the product.

Refill lubricant oil immediately when oil level is low as it may cause severe damages to the product.

Repair service may be necessary if the product requires frequent oil refill.  
Contact one of the office listed in the back of this manual/

## 7.4 Overhaul

Take the following precautions for a safe operation and prolonged pump life.

- (1) Operate the pump within the range described in the catalog and the instruction manual.
- (2) Perform maintenance as specified on P.40 (7. Maintenance) section.
- (3) Product inspection and overhaul service are available at EBARA service factory or one of the authorized service representative
- (4) When returning the pump, please attach Return Notice Sheet with the pump.
- (5) Please consult with our business offices listed in the back beforehand.

See table below for recommended overhaul cycle.

Recommended overhaul cycle	Example of usage/application
Every 1-2 years (with gas ballast)	Pumping condensable gases such as water vapor and solvent mixed gas. (Prior meeting is required when pumping solvent)
Every 3 years	Pumping clean gasses such as dry air and inert gases (N <sub>2</sub> , etc).

Overhaul cycle may change in response to the condition of the usage.

When the gas to be pumped is very reactive or corrosive, it may be necessary to have overhauled more than once a year.

<Notice>

Please fill out Return Notice Form attached end of this manual and provide necessary information prior to returning the product.

Dry out pump inside prior to returning the product if it was used to pump condensable gases.

For safety reasons, replace remaining gases with N<sub>2</sub> (nitrogen) completely and seal inlet and outlet port with blank off caps prior to returning the pump for repair/overhaul service if the pump was used to pump toxic gases.

The product may not be accepted if it was used for pumping arsenic gas or phosphorous gas. Please consult with our business office beforehand.

- (6) Turn around time and service procedure may be different for the product with special specifications. Please consult with our business office beforehand.
- (7) When the pump is unused for a long period of time, purge the pump well with N<sub>2</sub> then seal the inlet and outlet port with blank flanges immediately.

For repair service, contact one of the office listed in the back of this manual.

## 7.5 Removal of the Pump

### **DANGER**

Turn off the main switch on the pump and disconnect power cable before servicing. Do not supply power before completion of service work.

### **WARNING**

Wiring work must be done by qualified workers.

Pump remains hot during and/or after operation. Avoid direct skin contact otherwise it may cause burn. Keep combustible materials away from the product. Do not attempt to service the product when it is hot.

Do not remove packaging covers during operation.

### **CAUTION**

Do not lift the pump by your self. Lift the pump by hand with two (2) persons.

Do not use sling or the like to lift the pump as the handles are not designed to be used with slings.

Follow the procedure below when removing the pump from facility.

- 1) Stop the pump and replace remaining gases completely with N2 gas.
- 2) Turn off power supply and disconnect the power cable.
- 3) Remove the inlet and the outlet pipe, and seal the inlet and the outlet port with blank flanges.
- 4) Packing

## 8. TROUBLESHOOTING

### **DANGER**

Turn off the main switch on the pump and disconnect power cable before servicing. Do not supply power before completion of service work.

### **WARNING**

Wiring work must be done by qualified workers.

Pump remains hot during and/or after operation. Avoid direct skin contact otherwise it may cause burn. Keep combustible materials away from the product. Do not attempt to service the product when it is hot.

Do not remove packaging covers during operation.

### 8.1 Primary Trouble

Symptoms	Probable Causes	Corrective measures
PUMP does not start	The power isn't supplied to the pump.	Check if the power is supplied to the pump.
	Pump error	Pump replacement or overhaul is needed.
	The driving connector doesn't install on the I/O connector (CN2)	When "Direct power input" is selected, set driving connector onto "I/O connector (CN2)".
Abnormal noise. Intense vibration	Some objects on the outside cover.	Take the objects away.
	Vises to fix the outside cover are loosened.	Tighten the vises.
	Resonance of flexible tubes for inlet/exhaust.	Fix the resonant part.
	Pump parts damages.	Pump replacement or overhaul is needed.
	Cooling fan error	Pump maintenance or parts replacement is needed.
Insufficient Vacuum.	Pump error	Pump replacement or overhaul is needed.
	Pipe leakage in the fore line.	Check plumbing.
	The inside of the pump is dirty. (Moisture condensation etc.)	Pump overhaul is needed.
	The gas ballast valve is opened.	Close the gas ballast valve.
Breaker trip	The capacity of the breaker is small	Use recommended breaker.
	Pump error	Pump replacement or overhaul is needed.
	Motor error	Motor replacement or overhaul is needed.
	Incompleteness of power supply or wiring	Repair the power supply and wiring.

※Please contact the business office/branch at the end of the book when the troubles other than listed above occur.

## 8.2 Pump Malfunction

When abnormality occurs in the pump, the following message is displayed in the LED display on the controller. Press STOP/RESET button on the controller after solving the problem. The error will be reset.

LED display	Contents	Cause	Corrective measures
E01.□	During low speed	High voltage protection	<ul style="list-style-type: none"> <li>Needs to overhaul pump. (Foreign object may intrude into pumping room.)</li> <li>Check outlet piping.</li> </ul>
E02.□	During deceleration		
E03.□	During acceleration		
E04.□	Other		
E05.□	Overload protection		
E07.□	Over voltage protection	• Sudden load shift, voltage in power uprising	• Check voltage in power is uprising.
E08.□	EEPROM error	• Internal memory error	• Needs to check and repair of electric parts.
E09.□	Under voltage	• Power voltage abnormality	• Check voltage in power is short.
E10.□	Current detected error	• Inverter error	<ul style="list-style-type: none"> <li>Needs to check and repair electric parts.</li> <li>Needs to overhaul pump.</li> </ul>
E11.□	CPU error	• Pump error	
E14.□	Earth protection	Inverter error	<ul style="list-style-type: none"> <li>There should be source of noise near the pump. Consider plan to decrease its noise</li> <li>Needs to check and repair electric parts.</li> <li>Needs to overhaul pump.</li> </ul>
E15.□	Incoming high voltage protection		
E19.□	Temperature detection error		
E21.□	Fin temperature error		
E22.□	CPU communication error		
E25.□	Main circuit error		
E30.□	Driver error		
E35.□	Thermistor error	Pump temperature uprising	<ul style="list-style-type: none"> <li>Make sure surrounding temperature is proper range.</li> <li>Needs to check and repair electric parts. (air-cooled fan may be stopped)</li> </ul>
E37.□	Thermostat error		
E38.□	Overload protection during low speed	• Overload when the pump starts	<ul style="list-style-type: none"> <li>Make sure outlet piping is not stuffed.</li> <li>Needs to overhaul pump. (Foreign object may intrude into pumping room.)</li> </ul>
E50.□	Shaft lock	• Overload when the pump starts	
E51.□	Low speed	• Number of rotation is decreasing	

Note 1) :Abnormality will not be reset for 10 seconds after alarm occurred.

### How to use LED monitor

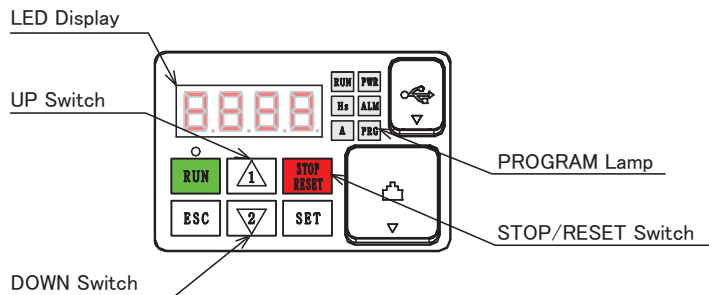
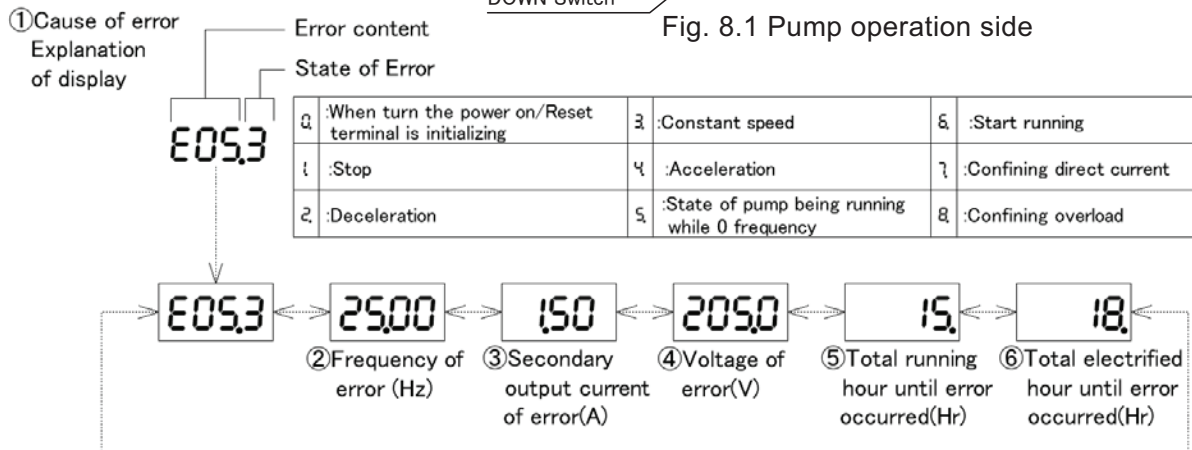

Fig. 8.1 Pump operation side



## 9. SCRAPPING METHOD

The pump main body and peripheral units may have been polluted by hazardous substances depending on each applied process.

Perform scrapping in compliance with the safety control standards of the nation and each local self-governing body.

## 10. PRECAUTIONS ON RETURN OF PRODUCT

### 10.1 Notes

When returning the pump and peripheral units to us for an overhaul, repair, etc. be sure to clarify the applied gas and products. This is duty-bound by the Industrial Safety and Health Law.

Before returning a unit, fill the Return Notice Sheet attached to this manual with necessary contents and submit it by FAX or mail. The user may have to return it to the approved dealer depending on the applied gas. The above request will lead to a smooth repair or overhaul.

If this sheet is not submitted, the returned product may be regarded as a hazardous substance and be rejected.

### 10.2 Returning Procedure

For a return, observe the following procedure.

- 1) Copy the Return Notice Sheet attached at the end of this manual and fill it with necessary contents.
- 2) Operate the pump while charging inert gas such as N<sub>2</sub> gas to remove toxic gas and corrosive gas completely from the pump. For the peripheral unit to be returned, eliminate toxic gas by charging inert gas. When solutions and lubricating oil can be disposed of properly on the user side, bleed them completely.
- 3) Remove all the accessories which are attached to the equipment.
- 4) Seal up the inlet port and outlet port of the pump by using blank flanges.
- 5) Seal up the product to be returned if possible after putting them in a polyethylene case or polyethylene sheet.
- 6) When returning the pump or unit, put the product to be returned on a wood pallet with a size of 510 mm x 915 mm or less and fix it with bands. In case of a large product which cannot be put on such a pallet, please ask us for information.
- 7) If the product to be returned is not so large as being fixed on a pallet, pack it in a solid case.
- 8) If the product to be returned is polluted, observe the law related to the transportation of hazardous substances, and stick a label having an indication to this effect on a pallet or case.
- 9) Submit the Return Notice Sheet filled with necessary contents to us by FAX or mail. This Return Notice Sheet should reach us earlier than the product to be returned.
- 10) Hand over a copy of the Return Notice Sheet to the forwarding agent. If the product to be returned is polluted, be sure to inform the forwarding agent of this effect.
- 11) Put the original of the Return Notice Sheet into an envelope and stick it on the outside of the product to be returned.

## Return Notice Sheet

Date : \_\_\_\_\_.

## I. Product to be returned

i) Model No. of the product be returned \_\_\_\_\_

ii) Serial No. of the product to be returned \_\_\_\_\_

## II. Pollution of the product to be returned

i) Applied process name \_\_\_\_\_

ii) Pollutant table

	Pollutant name	Chemical symbol	Precaution on Handling	Action to be taken for accidental inhalation or touch
1				
2				
3				
4				
5				
6				

## III. Reason for return

i) \*Overhaul      \*Failure      \*Other (                      )

ii) Contents of failure

## IV. Person in charge and where to contact

Name : \_\_\_\_\_ (signature)                      Post : \_\_\_\_\_

Company name / plant name : \_\_\_\_\_

Address : \_\_\_\_\_

Telephone / FAX No. :   TEL                                      FAX

Date of return : \_\_\_\_\_

# Global Network (ENG)

## USA

### EBARA TECHNOLOGIES INCORPORATED

HEADQUARTERS/FSC  
SACRAMENTO (CA)

51 MAIN AVENUE, SACRAMENTO, CA 95838  
PHONE:1-916-920-5451  
FAX:1-916-830-1900

**Service Locations:**

<http://www.ebaratech.com/>

## EUROPEAN UNION

### EBARA PRECISION MACHINERY EUROPRE GMBH

HEADQUARTERS  
HANAU, GERMANY

RODENBACHER CHAUSSEE 6 D-63457 HANAU, GERMANY  
PHONE:49-6181-1876-0  
FAX:49-6181-1876-40

FSC  
LIVINGSTONE, SCOTLAND

3/4 ADAM SQUARE, BRUCEFIELD INDUSTRIAL PARK,  
LIVINGSTONE, WEST LOTHIAN, EH54 9DE, U.K.  
PHONE:44-1506-460232  
FAX:44-1506-460222

**Service Locations:**

<http://www.ebara-pm.eu/about-us/locations.html>

## KOREA

### EBARA PRECISION MACHINERY KOREA INC.

HEADQUARTERS  
20FL, KANGNAM BLDG. 1321  
SEOCHO-DONG, SEOCHO-KU, SEOUL,KOREA  
PHONE:82-2-581- 6901  
FAX:82-2-581-4211

FSC  
MOGOK-DONG

446-4, MOGOK-DONG, SEOCHO-KU, SEOUL KOREA  
PHONE:82-31-665-0001  
FAX:82-31-665-0003

**URL (Korean):**

<http://ebara.co.kr/index.php>

## TAIWAN

### EBARA PRECISION MACHINERY TAIWAN INC.

HEADQUARTERS  
TAIPEI

ROOM 1402 CHIA HSIN BLDG.,NO.96, SECRETARY. 2,  
CHUNG SHAN N. RD.,TAIPEI TAIWAN, R.O.C. 104  
PHONE:886-2-2560-1166  
FAX:886-2-2560-1177

FSC  
HU-KOU

5, TZU-CHIANG RD.,HSIN-CHU LND.PARK. TAIWAN, R.O.C.303  
PHONE:886-3-597-3300  
FAX:886-3-597-7733

**Service Locations (Chinese):**

<http://www.ebara-tp.com.tw/service.htm>

## SINGAPORE

### EBARA ENGINEERING SINGAPORE

NO.1 TUAS LINK 2 SINGAPORE-638550  
PHONE:65-6862-3536  
FAX:65-6861-0589,6862-5937

**URL:**

[http://www.ebara.com.sg/index.php?option=com\\_frontpage&Itemid=1](http://www.ebara.com.sg/index.php?option=com_frontpage&Itemid=1)

## CHINA

### SHANGHAI EBARA PRECISION MACHINERY CO., LTD.

ZHANGJIANG HIGH-TECHNIC PARK, NO.76 LANE 887,  
ZUCHONGZHI ROAD, SHANGHAI, 201203, CHINA  
PHONE:86-21-5131-7008  
FAX:86-21-5131-7048

**URL (Chinese):**

<http://www.sepm-ebara.com/cn/index.php>

## JAPAN

### EBARA FIELD TECH CORPORATION

2-1, HON-FUJISAWA 4-CHOME, FUJISAWA,KANAGAWA,  
251-8502, JAPAN  
PHONE:81-466-83-9171  
FAX:81-0466-83-1100

**Service Locations (Japanese):**

<http://www.eft.ebara.com/company/soffice.html>



### EBARA CORPORATION

PRECISION MACHINERY.FUJISAWA PLANT  
2-1, HON-FUJISAWA 4-CHOME, FUJISAWA,  
KANAGAWA, 251-8502, JAPAN  
PHONE:81-466-83-8111 FAX:81-466-82-0127

URL:<http://www.ebara.co.jp/en/business/precision/>