

DIVAC Program Overview

This range of vacuum pumps was developed especially for laboratory operations and as backing pumps for (wide range) turbomolecular pumps. It satisfies the highest expectations in terms of precision, reliability and ease of use.

The DIVAC line of vacuum pumps is the logical continuation of diaphragm pump technology which has proven its quality in decades of service.

Laboratory Pumps

Through the laboratory pumps and the three different pumping speeds available for the same base pressure and through the modular design, the optimum pump system can be implemented for every application.

DIVAC L diaphragm pumps are suited for almost all requirements in the chemistry lab. They are basically corrosion and solvent resistant since their parts in contact with the pumped medium are made of PTFE (Teflon), FFPM (Kalrez) and PVDF (Solef).

Backing Pumps

The DIVAC T range of diaphragm pumps comprises backing pumps which are used in all applications requiring an especially low base pressure while having to maintain an oil-free vacuum.

The DIVAC T pumps have been specially developed as backing pumps for wide range high vacuum turbomolecular pumps. They meet the requirements for a dry vacuum and a long service life.

DIVAC T pumps may be used both free-standing and integrated in applications or certain devices, and for this reason they are used in the areas of mass spectrometry, analytical and in general applications.

Application Examples

Laboratory Pumps

- Vacuum filtration
- Vacuum distillation
- Vacuum drying
- To extract and transfer gases
- On rotary evaporators
- Gel drying

Backing Pumps

- Backing pump for wide range turbomolecular pumps
- Mass spectrometry
- Medicine technology
- Analytical technology
- General rough and medium vacuum applications

The customized Diaphragm Pump and the Accessories recommended for your Applications

Modular diaphragm pump system	DIVAC 0.6 L	DIVAC 1.2 L	DIVAC 2.2 L	DIVAC 1.4 HV3C	DIVAC 0.8 T	DIVAC 0.8 TL	DIVAC 1.4 HV3	DIVAC 3.8 HV3	DIVAC 4.8 VT
Applications									
Evacuating small devices (e.g. desiccator)	■	■	■	■					
Sublimation	■	■	■	■					
Analysis preparation	■	■	■	■					
Filtration	■	■	■	■					
Distillation	■	■	■	■					
Drying in the drying cabinet			■	■					
Drying cabinets (2 cabinets with 1 pump)			■	■					
Rotary evaporator		■	■	■					
Backing pumps for wide range turbomolecular pumps				■	■	■	■	■	■
Mass spectrometry				■	■	■	■	■	■
Medical technology				■	■	■	■	■	■
Analytical technology				■	■	■	■	■	■
General applications in the rough and medium vacuum range	■	■	■	■	■	■	■	■	■

Dry Compressing
Vacuum Pumps

Modular Diaphragm Pump System for the Chemical Laboratory

Advantages to the User

- Low base vacuum of 8 mbar (6 Torr) for two-stage and 2 mbar (1.5 Torr) for three-stage DIVAC
- All parts of the pump head in contact with the gas are resistant against aggressive media through the use of PTFE (Teflon), FFPM (Kalrez) and PVDF (Solef)
- Dry compressing, oil-free
- Water vapor tolerance
- Low maintenance costs and long service intervals through the use of high-quality components which are well-proven
- Simple maintenance by staff of the customer
- Low noise operation
- Portable, compact, small footprint
- Can be operated in any orientation
- Overheat protection for the vacuum pump by means of a thermal fuse
- Available in four pumping speed categories

Products

Diaphragm Vacuum Pumps for the Chemical Laboratory

Dual-Stage Diaphragm Vacuum Pumps DIVAC 0.6 L, 1.2 L, 2.2 L

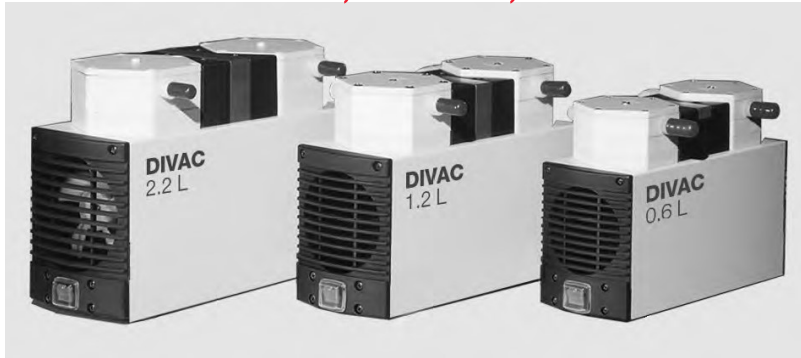

Typical Applications

Vacuum generation for

- Rotary evaporators
- Drying chambers
- Filtration units
- Distillation configurations
- Gel dryers

Dual-stage diaphragm vacuum pumps DIVAC 0.6 L, 1.2 L, 2.2 L

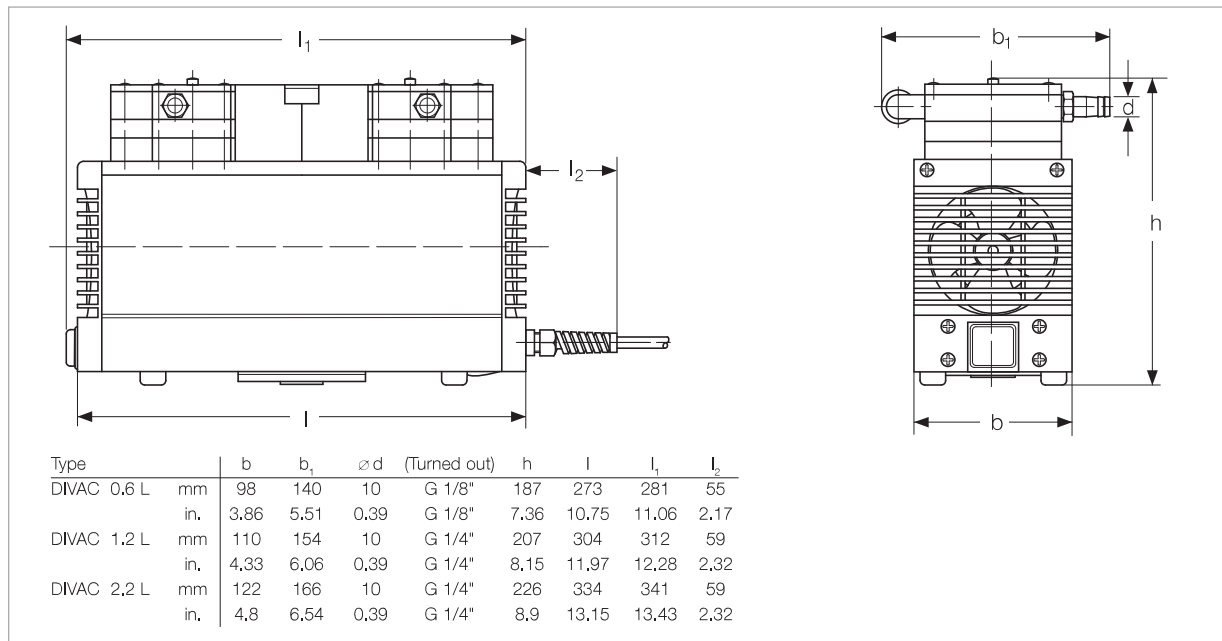

Dimensional drawing for the DIVAC 0.6 L, 1.2 L, 2.2 L

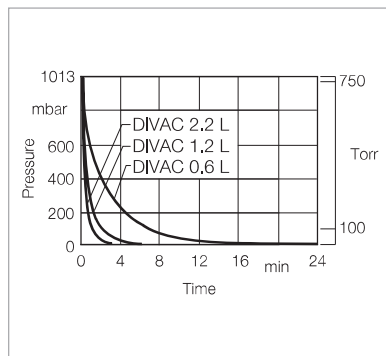

Curves of pump-down time of a 10 l vessel

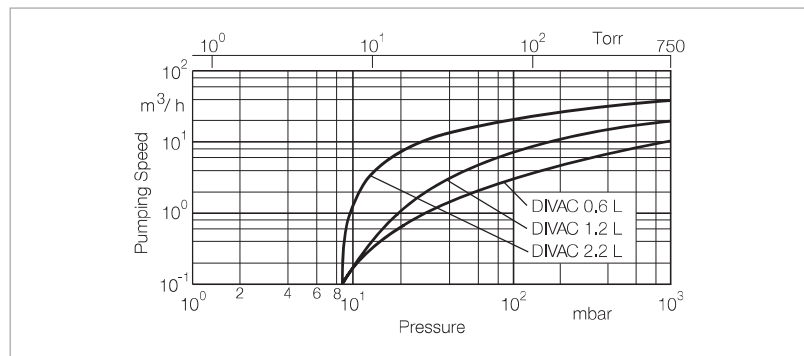

Curves of pumping capacity

Technical Data
DIVAC

		0.6 L	1.2 L	2.2 L
Max. pumping speed (atm.)	m ³ /h ¹ (cfm)	0.6 (0.4)	1.2 (0.7)	2.0 (1.2)
Ultimate pressure	mbar (Torr)	≤ 8 (≤ 6)		
Max. exhaust back pressure (absolute)	mbar (Torr)	2000 (1500)		
Pump heads		2		
Connection				
Inlet (suction side)	DN	Hose nozzle ID 10	Hose nozzle ID 10	Hose nozzle ID 10
Exhaust (delivery side)	DN	Hose nozzle ID 10	Hose nozzle ID 10	Hose nozzle ID 10
Thread (suction and delivery side)	G	G 1/8"	G 1/4"	G 1/4"
Noise level acc. to DIN 45 635 Part 13, approx.	dB(A)	47	50	52
Permissible gas admission temperature, max.	°C (°F)	+5 to +40 (+41 to +104)		
Permissible ambient temperature, max.	°C (°F)	+5 to +40 (+41 to +104)		
Voltage / nominal frequency (1-ph. motor)				
Schuko plug	V / Hz	230 ± 10% / 50		
NEMA plug	V / Hz	115 ± 10% / 60		
NEMA plug	V / Hz	100 ± 10% / 50/60		
Protective class	IP	44		
Motor power ¹⁾	W	90	120	245
Current consumption ¹⁾	A	0,6	0,7	1,8
Motor speed				
50 Hz	min ⁻¹	1500		
60 Hz	min ⁻¹	1800		
Dimensions (W ¹⁾ x H ¹⁾ x D), approx	mm (in.)	281 x 140 x 187 (11.06 x 5.51 x 7.36)	312 x 154 x 207 (12.28 x 6.06 x 8.15)	341 x 166 x 226 (13.43 x 6.54 x 8.9)
Weight, approx.	kg (lbs)	6.9 (15.2)	9.3 (20.5)	12.6 (27.8)
Material				
Pump head		PTFE (Teflon)		
Structured diaphragm		PTFE coated		
Valves		FFPM (Kalrez)		
Nozzles		PVDF (Solef)		

Ordering Information
DIVAC

	0.6 L	1.2 L	2.2 L
	Part No.	Part No.	Part No.
Diaphragm vacuum pump 230 V, 50 Hz, with 2.3 m (8 ft) power cord and Schuko plug	135 00	135 06	135 12
Diaphragm vacuum pump 100 V, 50/60 Hz, with 2.3 m (8 ft) power cord and NEMA plug	-	-	135 14
Spare parts kit consisting of 2 diaphragms, 4 gasket rings, 4 valve plates	EK135 23	EK135 24	EK135 25
Hose nozzle kit consisting of 2 hose nipples, piping	-	200 650 06	200 650 07

¹⁾ For 230 V, 50 Hz version

Three-Stage Diaphragm Vacuum Pumps

DIVAC 1.4 HV3C



The DIVAC 1.4 HV3C is a three-stage diaphragm pump capable of resisting chemicals and offering an improved pumping performance. Its speed is infinitely variable from 700 to 1600 rpm so that the pumping speed of the pump can be easily adapted to differing requirements. The built-in textured diaphragm is PTFE coated. The valves are made of FFKM thereby ensuring excellent resistance also in connection with aggressive gases. Owing to the three-stage design, pressures of 2 mbar can be attained very easily.

Three-stage diaphragm vacuum pump DIVAC 1.4 HV3C

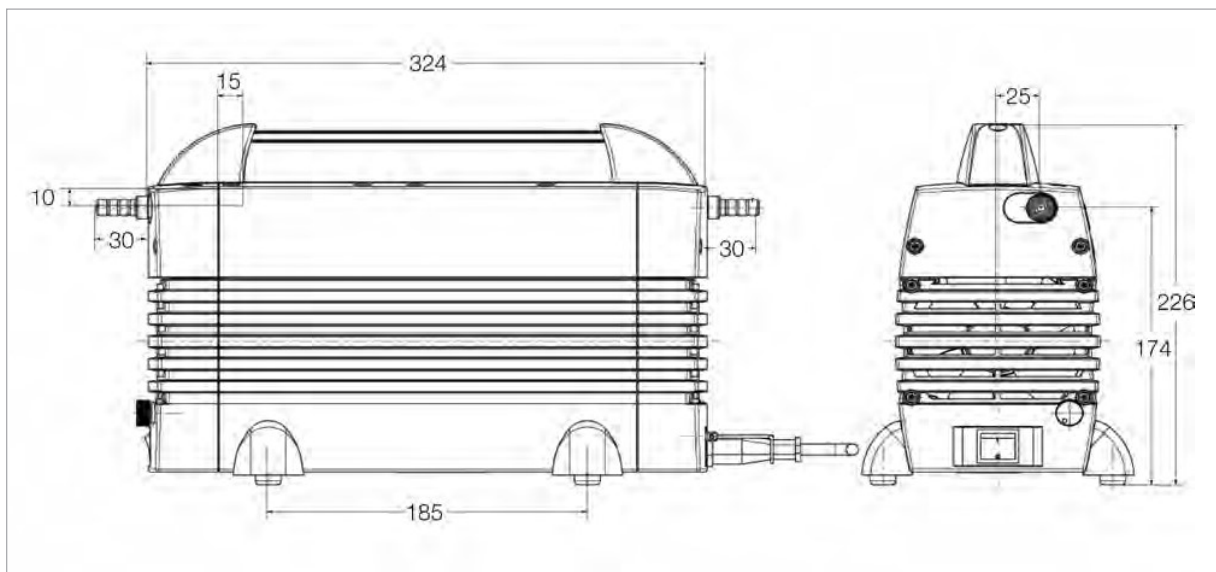

Dimensional drawing for the DIVAC 1.4 HV3C

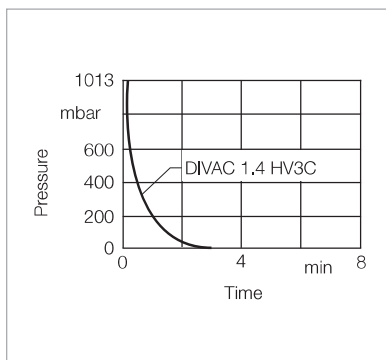

Curves of pump-down time of a 10 l vessel

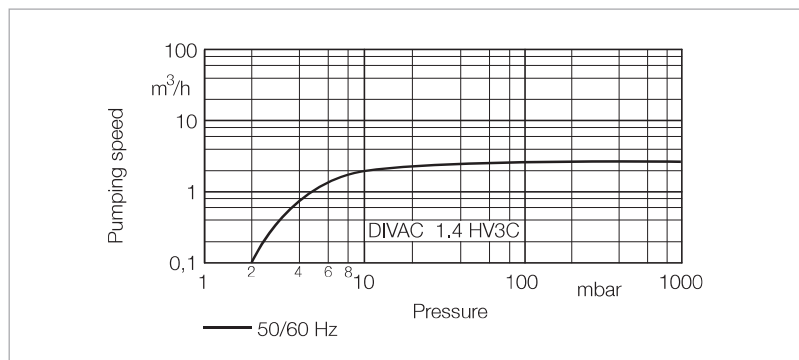

Curves of pumping capacity

Technical Data
DIVAC 1.4 HV3C

Max. pumping speed	m ³ /h ¹ (cfm)	1.3 (0.77)
Ultimate pressure	mbar (Torr)	≤ 2.0 (≤ 1.5)
Max. exhaust back pressure (absolute)	mbar (Torr)	1500 (1125)
Pump heads		3
Connection		
Inlet (suction side)	DN	Hose nozzle ID 10
Exhaust (delivery side)	DN	Hose nozzle ID 10
Thread (suction and delivery side)	G	G 1/8"
Noise level acc. to DIN 45 635 Part 13, approx.	dB(A)	48
Permissible gas admission temperature, max.	°C (°F)	+5 to +40 (+41 to +104)
Permissible ambient temperature, max.	°C (°F)	+5 to +40 (+41 to +104)
Voltage / nominal frequency	V / Hz	90 – 230 / 50 – 60
Protective class	IP	20
Motor power ¹⁾	W	135
at ultimate pressure	W	35
Current consumption ¹⁾	A	1.3
Motor speed	min ⁻¹	700 to 1600
Dimensions (W ¹⁾ x H ¹⁾ x D), approx	mm (in.)	324 x 158 x 226 (12.76 x 6.22 x 8.90)
Weight, approx.	kg (lbs)	8,6 (18,99)
Material		
Pump head		PPS
Structured diaphragm		PTFE coated
Valves		FFPM
Nozzles		PVDF

Ordering Information
DIVAC 1.4 HV3C

	Part No.
Diaphragm vacuum pump 90 – 230 V, 50 – 60 Hz, with 2,3 m (8 ft) power cord and Schuko plug	135 20 V
Accessories Exhaust silencer 1.4 with connection G 1/8"	127 90 A

¹⁾ For 230 V, 50 Hz version

Dry Compressing Backing Pumps for Turbomolecular Pumps

DIVAC 0.8 T to 4.8 VT



Our dry compressing backing pumps from the DIVAC T series are now supplemented by the three-stage DIVAC 1.4 HV3 and the DIVAC 3.8 HV3. Like the proven DIVAC T series, these new models also ensure a forevacuum free of hydrocarbons. Owing to their three-stage design, they provide especially within the lower pressure ranges a higher pumping speed and are therefore even better suited as backing pumps for turbomolecular pumps. But they are also used as backing pumps operating in the rough and medium vacuum range to pump clean media.

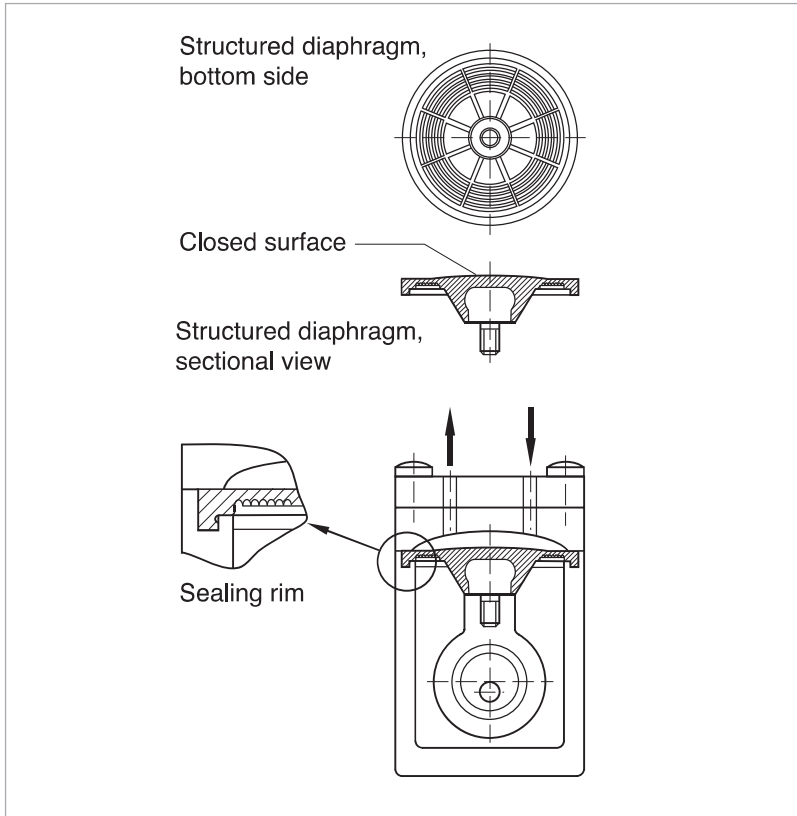

Diaphragm pump with structured diaphragm

The structured diaphragm with its sealed surface provides the basis for a long service life and a low base pressure.

Advantages to the User

- Dry compressing, free of oil and hydro-carbons
- Matched to the turbomolecular pumps from Leybold (SL 80 to TURBOVAC 450i)
- Low ultimate pressure
- ISO-KF flange at the intake port
- Fully equipped with cable, switch (ON/OFF) and plug
- Better performance and smaller size through the use of structured diaphragms
- Low vibration levels through dynamic mass balancing (in VT pumps)
- Lower maintenance costs and long maintenance intervals through the use of high-quality and well-proven components
- Simple maintenance
- Favourable price-to-performance ratio
- Can be operated in any position

Typical Applications

- Backing pump for wide pressure range turbomolecular pumps
- Mass spectrometers
- Medical equipment
- Analyzes
- For laboratory applications also with corrosive media
- General use for rough and fine vacuum applications

DIVAC 0.8 T and 0.8 LT



DIVAC 0.8 T



DIVAC 0.8 LT

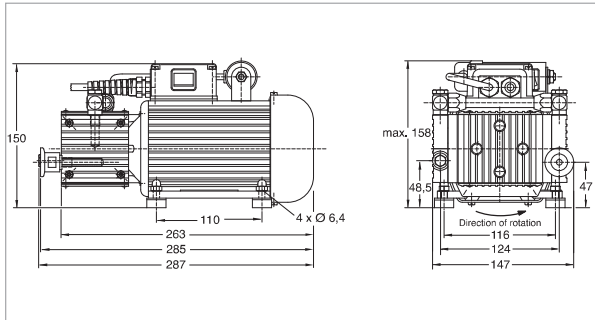

Dimensional drawing for the DIVAC 0.8 T

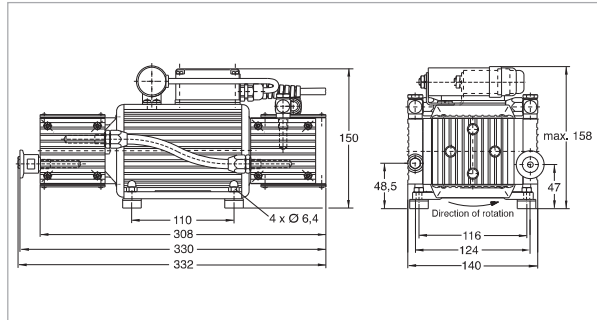

Dimensional drawing for the DIVAC 0.8 LT

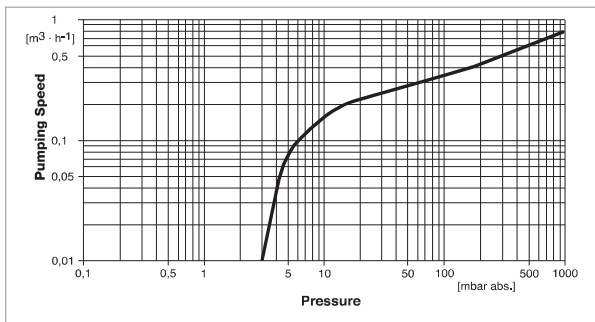

Pumping speed curve of the DIVAC 0.8 T

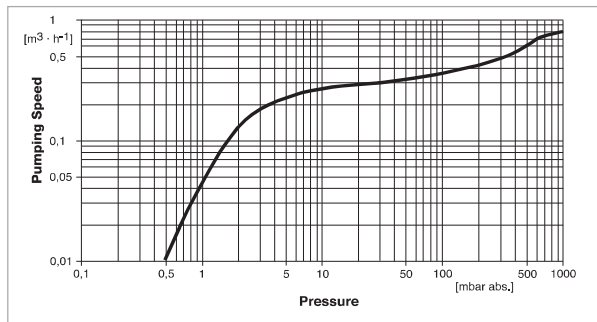

Pumping speed curve of the DIVAC 0.8 LT

Technical Data
DIVAC

		0.8 T	0.8 LT
Max. pumping speed (atm.)	m ³ /h ¹ (cfm)	0.77 (0.45)	
Ultimate pressure	mbar (Torr)	≤ 3.0 (≤ 2.25)	≤ 0.5 (≤ 0.38)
Max. exhaust back pressure (absolute)	mbar (Torr)	2000 (1500)	
Pump heads		2	4
Connection			
Inlet (suction side)	DN	16 KF	
Exhaust (delivery side)	DN	Silencer	
Thread (suction and delivery side)	G	G 1/8"	
Noise level acc. to DIN 45 635 Part 13, approx.	dB(A)	49	53
Permissible gas admission temperature, max.	°C (°F)	+5 to +40 (+41 to +104)	
Permissible ambient temperature, max.	°C (°F)	+5 to +40 (+41 to +104)	
Voltage / nominal frequency (1-ph. motor)			
Schuko plug	V / Hz	198 – 264 / 50/60	230 / 50 ± 10%
NEMA plug	V / Hz	90 – 127 / 50/60	115 / 60 ± 10%
Protective class	IP	44	
Motor power ¹⁾	W	50	80
Current consumption ¹⁾	A	0.4	0.5
Nominal speed, approx. (50/60 Hz)	min ⁻¹	1500/1800	
Dimensions (W ¹⁾ x H ¹⁾ x D), approx	mm (in.)	285 x 150 x 150 (11.22 x 5.9 x 5.9)	332 x 150 x 150 (13.07 x 5.9 x 5.9)
Weight, approx.	kg (lbs)	5.9 (13.02)	7.5 (16.56)
Material			
Pump head		Aluminum	
Diaphragm		Neoprene	
Valves		EPDM	

Ordering Information
DIVAC

	0.8 T	0.8 LT
	Part No.	Part No.
Diaphragm vacuum backing pumps for turbomolecular pumps including 1 m (3.5 ft) long mains cord, country-specific plug, silencer, rubber feet, as well as ON/OFF switch 198 – 264 V / 50/60 Hz 230 V ± 10% / 50 Hz 90 – 127 V / 50/60 Hz	127 80 - 127 81	- 127 83 -
Spare parts kit consisting of 2 diaphragms, 4 valves, 4 valve gaskets, 4 piping gaskets	EK 127 95	EK 127 95 (2x)
Exhaust silencer	127 98	127 98

T = For use in connection with Turbomolecular pumps

L = Very low ultimate pressure (Low pressure)

V = Low vibration levels (Low Vibration)

DIVAC 1.4 HV3 and 3.8 HV3



DIVAC 1.4 HV3



DIVAC 3.8 HV3

The three-stage DIVAC 1.4 HV3 and the DIVAC 3.8 HV3 provide especially in the lower pressure range a higher pumping speed compared to conventional diaphragm pumps. At the same time they are capable of attaining ultimate pressures below 2 mbar (1.5 Torr) and are thus very well suited as backing pumps for turbomolecular pumps. Owing to their compact design they are also suited for installation within pump systems.

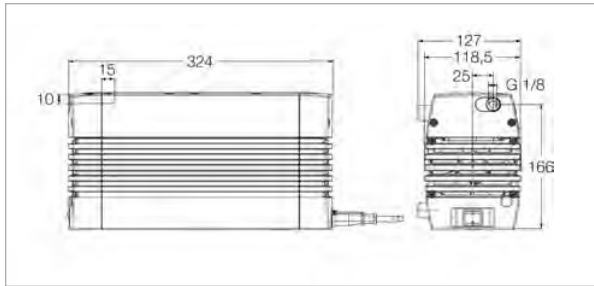

Dimensional drawing for the DIVAC 1.4 HV3

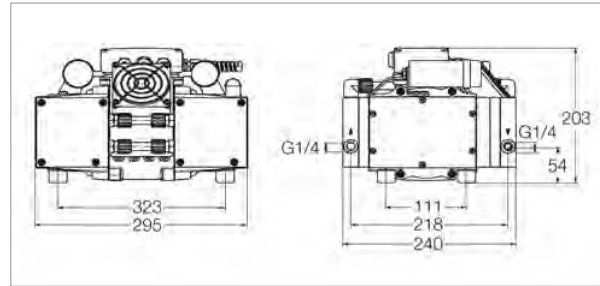

Dimensional drawing for the DIVAC 3.8 HV3

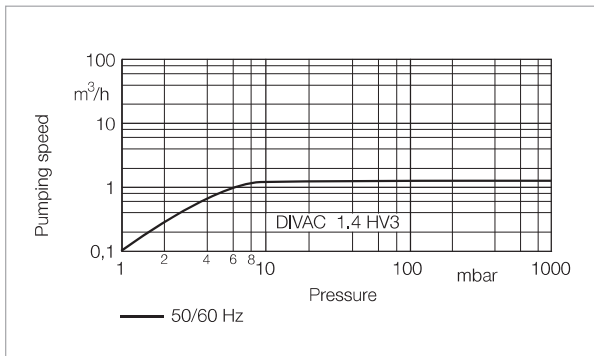

Pumping speed curve of the DIVAC 1.4 HV3

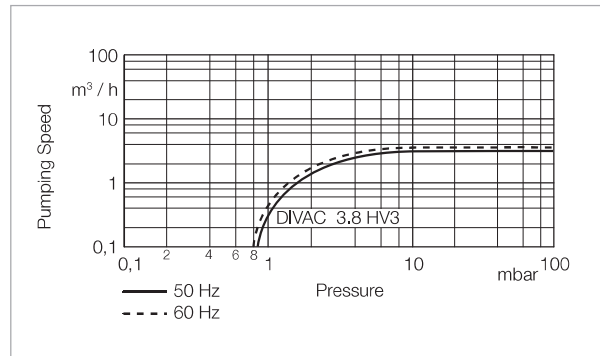

Pumping speed curve of the DIVAC 3.8 HV3

Technical Data
DIVAC

		1.4 HV3	3.8 HV3
Max. pumping speed			
50 Hz	m ³ /h ¹ (cfm)	1.3 (0.77)	3.4 (2.00)
60 Hz	m ³ /h ¹ (cfm)	–	3.8 (2.24)
Ultimate pressure	mbar (Torr)	≤ 1.5 (≤ 1.13)	≤ 1.0 (≤ 0.75)
Max. exhaust back pressure (absolute)	mbar (Torr)	1500 (1125)	
Pump heads		3	
Connection			
Inlet (suction side)	DN	Hose nozzle ID 9	Hose nozzle ID 9
Exhaust (delivery side)	DN	Hose nozzle ID 9	Hose nozzle ID 9
Thread (suction and delivery side)	G	G 1/8"	G 1/4"
Noise level acc. to DIN 45 635 Part 13, approx.	dB(A)	48	54
Permissible gas admission temperature, max.	°C (°F)	+5 to +40 (+41 to +104)	
Permissible ambient temperature, max.	°C (°F)	+5 to +40 (+41 to +104)	
Voltage / nominal frequency (1-ph. motor)			
Schuko plug	V / Hz	90 – 230 / 50-60	90 – 230 / 50-60
NEMA plug	V / Hz	–	115 / 50-60
Protective class	IP	20	
Motor power ¹⁾	W	120	250
at ultimate pressure	W	35	190
Current consumption ¹⁾	A	1.3	1.7
Nominal speed, approx. (50/60 Hz)	min ⁻¹	1500	1500/1800
Dimensions (W ¹⁾ x H ¹⁾ x D), approx	mm (in.)	324 x 158 x 226 (12.76 x 6.22 x 8.90)	295 x 240 x 203 (11.61 x 9.45 x 7.99)
Weight, approx.	kg (lbs)	10.5 (23.18)	18.9 (41.72)
Material			
Pump head		Aluminum	
Structured diaphragm		EPDM	
Valves		EPDM	
Nozzles		PA	

Ordering Information
DIVAC

	1.4 HV3	3.8 HV3
	Part No.	Part No.
Diaphragm vacuum backing pumps for turbomolecular pumps including 1 m (3,5 ft) long mains cord, country-specific plug, silencer, rubber feet, as well as ON/OFF switch		
90 – 230 V / 50 – 60 Hz	127 90 V	–
230 V / 50 – 60 Hz	–	127 95 V
115 V / 50 – 60 Hz	–	127 96 V
Exhaust silencer		
1,4 with connection G 1/8"	127 90 A	–
3,8 with connection G 1/4"	–	127 95 A
Spare parts kit	EK057456	EK12768

DIVAC 4.8 VT

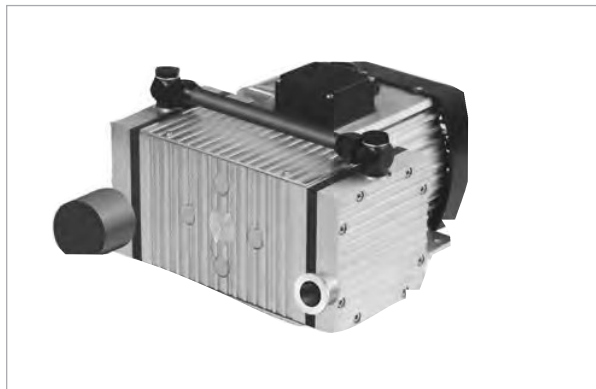

DIVAC 4.8 VT

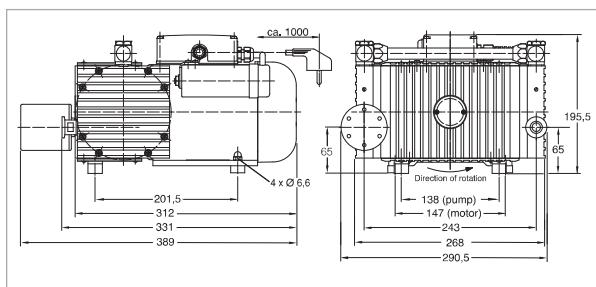

Dimensional drawing for the DIVAC 4,8 VT

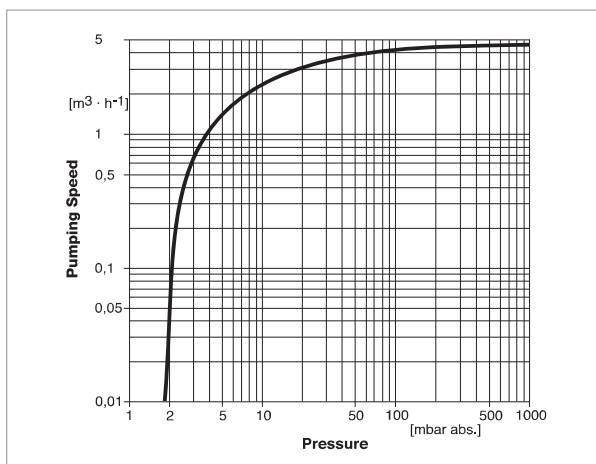

Pumping speed curve of the DIVAC 4.8 VT

Technical Data
DIVAC 4.8 VT

Max. pumping speed (atm.)	m ³ /h ¹ (cfm)	4.8 (2.83)
Ultimate pressure	mbar (Torr)	≤ 2.0 (≤ 1.5)
Max. exhaust back pressure (absolute)	mbar (Torr)	2000 (1500)
Pump heads		2
Connection		
Inlet (suction side)	DN	16 KF
Exhaust (delivery side)	DN	Silencer
Thread (suction and delivery side)	G	G 3/8"
Noise level acc. to DIN 45 635 Part 13, approx.	dB(A)	55
Permissible gas admission temperature, max.	°C (°F)	+5 to +40 (+41 to +104)
Permissible ambient temperature, max.	°C (°F)	+5 to +40 (+41 to +104)
Voltage / nominal frequency (1-ph. motor)		
Schuko plug	V / Hz	230 / 50 ± 10%
NEMA plug	V / Hz	115 / 60 ± 10%
Protective class	IP	54
Motor power ¹⁾	W	350
Current consumption ¹⁾	A	2.6
Nominal speed, approx. (50 Hz)	min ⁻¹	1500
Dimensions (W ¹⁾ x H ¹⁾ x D), approx	mm (in.)	324 x 273 x 220 (12.76 x 10.75 x 8.66)
Weight, approx.	kg (lbs)	18.0 (39.74)
Material		
Pump head		Aluminum
Diaphragm		EPDM
Valves		Viton

Ordering Information
DIVAC 4.8 VT

	Part No.
Diaphragm vacuum backing pumps for turbomolecular pumps including 1 m (3.5 ft) long mains cord, country-specific plug, silencer, rubber feet, as well as ON/OFF switch 230 V ± 10% / 50 Hz	127 92
Spare parts kit consisting of 2 diaphragms, 4 valves, 4 valve gaskets, 4 piping gaskets	EK 127 97
Exhaust silencer	127 94

T = For use in connection with Turbomolecular pumps

L = Very low ultimate pressure (Low pressure)

V = Low vibration levels (Low Vibration)