



OPERATING INSTRUCTIONS

EN

Translation of the Original

HISCROLL 12 | 18

Scroll pump

PFEIFFER  **VACUUM**

Dear Customer,

Thank you for choosing a Pfeiffer Vacuum product. Your new scroll pump is designed to support you with its performance, perfect operation and without impacting your individual application. The name Pfeiffer Vacuum stands for high-quality vacuum technology, a comprehensive and complete range of top-quality products and first-class service. From this extensive, practical experience we have gained a large volume of information that can contribute to efficient deployment and to your personal safety.

In the knowledge that our product must avoid consuming work output, we trust that our product can offer you a solution that supports you in the effective and trouble-free implementation of your individual application.

Please read these operating instructions before putting your product into operation for the first time. If you have any questions or suggestions, please feel free to contact info@pfeiffer-vacuum.de.

Further operating instructions from Pfeiffer Vacuum can be found in the [Download Center](#) on our website.

Disclaimer of liability

These operating instructions describe all models and variants of your product. Note that your product may not be equipped with all features described in this document. Pfeiffer Vacuum constantly adapts its products to the latest state of the art without prior notice. Please take into account that online operating instructions can deviate from the printed operating instructions supplied with your product.

Furthermore, Pfeiffer Vacuum assumes no responsibility or liability for damage resulting from the use of the product that contradicts its proper use or is explicitly defined as foreseeable misuse.

Copyright

This document is the intellectual property of Pfeiffer Vacuum and all contents of this document are protected by copyright. They may not be copied, altered, reproduced or published without the prior written permission of Pfeiffer Vacuum.

We reserve the right to make changes to the technical data and information in this document.

Table of contents

1	About this manual	8
1.1	Validity	8
	1.1.1 Applicable documents	8
	1.1.2 Variants	8
1.2	Target group	8
1.3	Conventions	8
	1.3.1 Pictographs	8
	1.3.2 Instructions in the text	8
	1.3.3 Stickers on the product	9
	1.3.4 Abbreviations	10
2	Safety	11
2.1	General safety information	11
2.2	Safety instructions	11
2.3	Safety precautions	15
2.4	Limits of use of the product	16
2.5	Proper use	16
2.6	Foreseeable improper use	16
2.7	Personnel qualification	17
	2.7.1 Ensuring personnel qualification	17
	2.7.2 Personnel qualification for maintenance and repair	17
	2.7.3 Advanced training with Pfeiffer Vacuum	18
3	Product description	19
3.1	Function	19
	3.1.1 Drive	20
	3.1.2 Cooling	20
	3.1.3 Shaft bearing	20
	3.1.4 Gas ballast	20
	3.1.5 Pressure sensor	20
3.2	Connections	21
3.3	Identifying the product	21
3.4	Product features	21
3.5	Scope of delivery	21
4	Transportation and Storage	22
4.1	Transporting the vacuum pump	22
4.2	Storing the vacuum pump	23
5	Installation	24
5.1	Set up the vacuum pump	24
5.2	Connecting the vacuum side	24
5.3	Connecting the exhaust side	25
5.4	Connecting the gas ballast external supply	26
5.5	Establishing the mains connection	27
6	Interfaces	29
6.1	Interface overview	29
6.2	"Remote" interface	29
	6.2.1 Inputs	30
	6.2.2 Outputs	30
	6.2.3 RS-485	31
6.3	Connection options	31
6.4	Interface RS-485	31
6.5	Pfeiffer Vacuum protocol for RS-485 interface	32
	6.5.1 Telegram frame	32
	6.5.2 Telegram description	33

6.5.3	Telegram example 1	33
6.5.4	Telegram example 2	33
6.5.5	Data types	33
7	Parameter set	35
7.1	General	35
7.2	Control commands	35
7.3	Status requests	36
7.4	Reference value inputs	37
7.5	Additional parameter for the DCU	37
8	Operation	39
8.1	Putting the vacuum pump into operation	39
8.2	Switch vacuum pump on	39
8.3	Configuring the connections with the Pfeiffer Vacuum parameter set	39
8.3.1	Configuring the digital outputs	39
8.3.2	Configure digital inputs	40
8.3.3	Selecting the interfaces	40
8.4	Operating modes	40
8.5	Speed modes	41
8.5.1	Normal operation	41
8.5.2	Standby mode	41
8.5.3	Speed actuator operation	42
8.5.4	Auto boost	42
8.5.5	Auto standby	42
8.6	Pressure regulation operation	43
8.7	Determining the effective pressure with calibration factors	43
8.8	Operation with gas ballast	44
8.9	Operating mode display via LED	45
8.10	Switching off the vacuum pump	46
9	Maintenance	47
9.1	Maintenance information	47
9.2	Checklist for inspection and maintenance	47
9.3	Calibrating the pressure sensor	48
9.4	Changing the tip seal	49
9.4.1	Disassembling the spiral housing	49
9.4.2	Replacing the tip seal	50
9.4.3	Assembling the pump housing	52
9.5	Final inspection	53
10	Decommissioning	54
10.1	Shutting down for longer periods	54
10.2	Recommissioning	54
11	Recycling and disposal	55
11.1	General disposal information	55
11.2	Disposing of the scroll pump	55
12	Malfunctions	56
12.1	General	56
12.2	Error codes	57
12.3	Warning and error messages when operating with DCU	58
13	Service solutions by Pfeiffer Vacuum	60
14	Accessories	62
14.1	Accessory information	62
14.2	Order accessories	62
15	Technical data and dimensions	63

15.1	General	63
15.2	Technical data	63
15.3	Substances in contact with the media	65
15.4	Dimensions	65
	Declaration of conformity	67

List of tables

Tbl. 1:	Stickers on the product	9
Tbl. 2:	Abbreviations used	10
Tbl. 3:	Permissible ambient conditions	16
Tbl. 4:	Interfaces of the electronic drive unit	21
Tbl. 5:	Features of scroll pumps	21
Tbl. 6:	Terminal lay-out of 15-pin "remote" connection	30
Tbl. 7:	Features of the RS-485 interface	31
Tbl. 8:	Explanation and meaning of the parameters	35
Tbl. 9:	Control commands	36
Tbl. 10:	Status requests	37
Tbl. 11:	Reference value inputs	37
Tbl. 12:	Parameter for DCU functions	38
Tbl. 13:	Configure parameters [P:019] and [P:024]	40
Tbl. 14:	Configure parameter [P:063]	40
Tbl. 15:	Parameter [P:060]	40
Tbl. 16:	Calibration factors for the pressure range < 1 hPa	44
Tbl. 17:	HiScroll gas ballast valve switch settings	45
Tbl. 18:	Behavior and meaning of the LEDS of the electronic drive unit	46
Tbl. 19:	Behavior and meaning of the LED standby	46
Tbl. 20:	Maintenance intervals	48
Tbl. 21:	Troubleshooting with scroll pumps	57
Tbl. 22:	Error messages of the electronic drive unit	58
Tbl. 23:	Warning messages of the electronic drive unit	58
Tbl. 24:	Warning and error messages when using a DCU	59
Tbl. 25:	Accessories for HiScroll	62
Tbl. 26:	Conversion table: Pressure units	63
Tbl. 27:	Conversion table: Units for gas throughput	63
Tbl. 28:	Technical data for HiScroll 12	64
Tbl. 29:	Technical data for HiScroll 18	65
Tbl. 30:	Materials that make contact with the process media	65

List of figures

Fig. 1:	Position of the stickers on the product	10
Fig. 2:	Schematic compression cycle of scroll pumps	19
Fig. 3:	HiScroll design	20
Fig. 4:	Slingshot points for transport of the scroll pump	22
Fig. 5:	Minimum clearances and permissible inclination	24
Fig. 6:	Example of vacuum connection	25
Fig. 7:	Example of exhaust connection	26
Fig. 8:	Connecting the gas ballast external supply	27
Fig. 9:	Establishing mains connection	28
Fig. 10:	Interfaces of the electronic drive unit	29
Fig. 11:	Connection diagram of 15-pin "remote" connection	29
Fig. 12:	Connecting a display and control unit via "remote"	31
Fig. 13:	Cross-link via connection RS-485 using connection cables and accessories	32
Fig. 14:	Speed modes	41
Fig. 15:	Displayed pressure	43
Fig. 16:	Loosening the fan cover on the scroll pump	49
Fig. 17:	Removing the fan cover on the scroll pump	49
Fig. 18:	Removing the scroll pump spiral housing	50
Fig. 19:	Replacing the tip seal on the scroll pump	51
Fig. 20:	Tip seal nut in the spiral housing	51
Fig. 21:	Assembling the housing parts	52
Fig. 22:	HiScroll 12 HiScroll 18	66

1 About this manual



IMPORTANT

Read carefully before use.
Keep the manual for future consultation.

1.1 Validity

This operating instructions is a customer document of Pfeiffer Vacuum. The operating instructions describe the functions of the named product and provide the most important information for the safe use of the device. The description is written in accordance with the valid directives. The information in this operating instructions refers to the product's current development status. The document shall remain valid provided that the customer does not make any changes to the product.

1.1.1 Applicable documents

Document	Number
Declaration of conformity	A component of these instructions

You can find this document in the [Pfeiffer Vacuum Download Center](#).

1.1.2 Variants

- HiScroll 12, Scroll Pump, Standard
- HiScroll 12, Scroll Pump, Standard, incl. pressure sensor
- HiScroll 18, Scroll Pump, Standard
- HiScroll 18, Scroll Pump, Standard, incl. pressure sensor

1.2 Target group

These operating instructions are aimed at all persons performing the following activities on the product:

- Transportation
- Setup (Installation)
- Usage and operation
- Decommissioning
- Maintenance and cleaning
- Storage or disposal

The work described in this document is only permitted to be performed by persons with the appropriate technical qualifications (expert personnel) or who have received the relevant training from Pfeiffer Vacuum.

1.3 Conventions

1.3.1 Pictographs

Pictographs used in the document indicate useful information.



Note



Tip

1.3.2 Instructions in the text

Usage instructions in the document follow a general structure that is complete in itself. The required action is indicated by an individual step or multi-part action steps.

Individual action step

A horizontal, solid triangle indicates the only step in an action.

- ▶ This is an individual action step.





Sequence of multi-part action steps

The numerical list indicates an action with multiple necessary steps.

1. Step 1
2. Step 2
3. ...

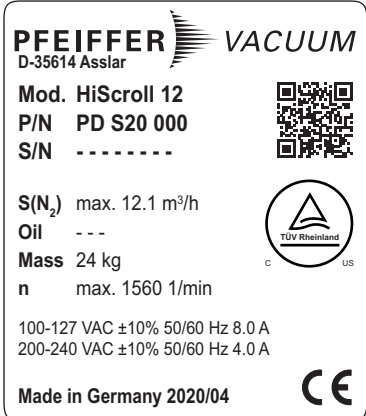
1.3.3 Stickers on the product

This section describes all the stickers on the product along with their meaning.

	<p>Rating plate</p> <p>The rating plate is located clearly visible on a longitudinal side of the vacuum pump.</p>
	<p>Warning hot surface</p> <p>This sticker warns of injuries caused by high temperatures in case of touching without protection during operation.</p>
	<p>Operating instructions note</p> <p>This sticker indicates that this operating instructions must be read before performing any tasks.</p>
	<p>Closure seal</p> <p>The product is sealed ex-factory. Damaging or removing a closure seal results in loss of the warranty.</p>

Tbl. 1: Stickers on the product

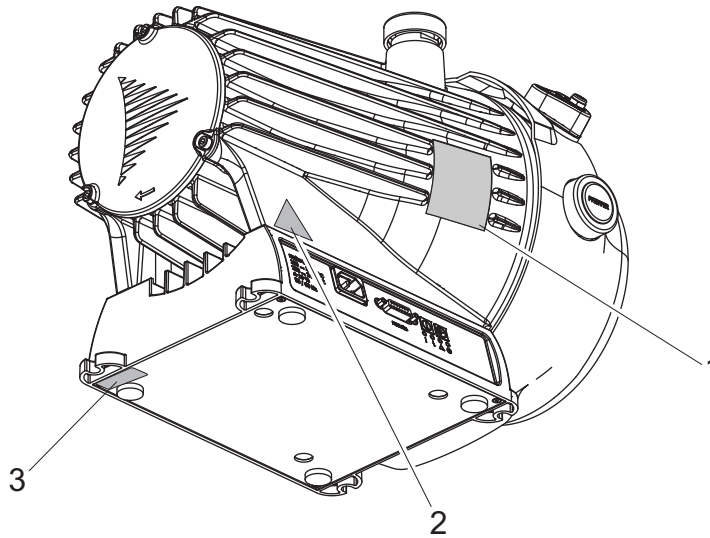

Fig. 1: Position of the stickers on the product

- 1 Rating plate
- 2 Hot surface warning sign
- 3 Closure seal

1.3.4 Abbreviations

Abbreviation	Explanation
ATM	Atmospheric pressure
OI	Operating instructions
DCU	Display Control Unit
f	Rotation speed value of a vacuum pump (frequency, in rpm or Hz)
FCR	Fluorinated rubber
HPU	Handheld Programming Unit
HV	High vacuum
[P:xxx]	Parameters are printed in bold as three-digit numbers in square brackets. Example: [P:xxx] Software version
PC	Personal computer
PTFE	Polytetrafluoroethylene
RCD	Residual Current Device
RPT	Digital pressure sensor (RPT 010)
RS-485	Standard for a physical interface for asynchronous serial data transmission (Recommended Standard)
SI	Service instructions
USB	Universal Serial Bus

Tbl. 2: Abbreviations used

2 Safety

2.1 General safety information

The following 4 risk levels and 1 information level are taken into account in this document.

DANGER

Immediately pending danger

Indicates an immediately pending danger that will result in death or serious injury if not observed.

- ▶ Instructions to avoid the danger situation

WARNING

Potential pending danger

Indicates a pending danger that could result in death or serious injury if not observed.

- ▶ Instructions to avoid the danger situation

CAUTION

Potential pending danger

Indicates a pending danger that could result in minor injuries if not observed.

- ▶ Instructions to avoid the danger situation

NOTICE

Danger of damage to property

Is used to highlight actions that are not associated with personal injury.

- ▶ Instructions to avoid damage to property



Notes, tips or examples indicate important information about the product or about this document.

2.2 Safety instructions

All safety instructions in this document are based on the results of the risk assessment carried out in accordance with Machinery Directive 2006/42/EC Annex I and EN ISO 12100 Section 5. Where applicable, all life cycle phases of the product were taken into account.

Risks during transport

WARNING

Risk of serious injury from swinging, toppling or falling objects

During transport, there is a risk of crushing and impact on swinging, toppling or falling objects. There is a risk of injuries to limbs, up to and including bone fractures and head injuries.

- ▶ Secure the danger zone if necessary.
- ▶ Pay attention to the center of gravity of the load during transport.
- ▶ Ensure even movements and moderate speeds.
- ▶ Observe safe handling of the transport devices.
- ▶ Avoid sloping attachment aids.
- ▶ Never stack products.
- ▶ Wear protective equipment, e.g. safety shoes.

Risks during installation

⚠ DANGER

Danger to life from electric shock

Inadequate or incorrect grounding of the unit leads to contact-sensitive voltage on the housing. When making contact, increased leakage currents will cause a life-threatening electric shock.

- ▶ Before the installation, check that the connection leads are voltage-free.
- ▶ Conduct the electrical connection in accordance with locally applicable regulations.
- ▶ Make sure that the local mains voltage and frequency match rating plate specifications.
- ▶ Make sure that the mains cable and extension cable meet the requirements for double isolation between input voltage and output voltage, in accordance with IEC 61010 and IEC 60950.
- ▶ Use only a 3-pin mains cable and extension cable with properly connected protective earthing (earthed conductor).
- ▶ Plug the mains plug into a socket with earthing contact only.
- ▶ Always connect the mains cable prior to all other cables, to ensure continuous protective earthing.

⚠ DANGER

Danger to life from electric shock

When establishing the voltages that exceed the specified safety extra-low voltage (according to IEC 60449 and VDE 0100), the insulating measures will be destroyed. There is a danger to life from electric shock at the communication interfaces.

- ▶ Connect only suitable devices to the bus system.

⚠ WARNING

Risk of fatal injury due to electric shock on account of incorrect installation

The device's power supply uses life-threatening voltages. Unsafe or improper installation can lead to life-threatening situations from electric shocks obtained from working with or on the unit.

- ▶ Ensure safe integration into an emergency off safety circuit.
- ▶ Do not carry out your own conversions or modifications on the unit.

⚠ WARNING

Risk of fatal injury due to electric shock caused by water damage

The device meets protection degree IP 20 according to EN 60529: 2014 and is not protected against water ingress. Vacuum pumps operated on the floor lead to leakage current in penetrating and surrounding water. There is a danger to life from electric shock when making contact with live water.

- ▶ In case of water damage, disconnect the complete power supply from the area affected.
- ▶ Provide an on-site electrical fuse protection (e.g. RCD) in hazardous areas.
- ▶ When selecting the installation location, observe potential damage from water.

⚠ WARNING

Danger to life from poisoning where toxic process gases leak with no exhaust line

During normal operation, the vacuum pump expels exhaust gases and vapors freely into the air. In processes involving toxic media, there is a risk of injury and danger to life due to poisoning.

- ▶ Observe the relevant regulations for handling toxic substances.
- ▶ Safely purge toxic process gases via an exhaust line.

⚠ CAUTION**Danger of injury from bursting as a result of high pressure in the exhaust line**

Faulty or inadequate exhaust pipes lead to dangerous situations, e.g., increased exhaust pressure. There is a danger of bursting. Injuries caused by flying fragments, the escaping of high pressure, and damage to the unit cannot be excluded.

- ▶ Open shut-off units immediately before or at the same time as starting the pump.
- ▶ Observe the maximum permissible pressure of 1,500 hPa (absolute).
- ▶ Observe the permissible pressures and pressure differentials for the product.
- ▶ Check the function of the exhaust line on a regular basis.

Risks during operation**⚠ WARNING****Danger of poisoning due to toxic process media escaping from the exhaust pipe**

During operation with no exhaust line, the vacuum pump allows exhaust gases and vapors to escape freely into the air. There is a risk of injury and fatality due to poisoning in processes with toxic process media.

- ▶ Observe the pertinent regulations for handling toxic process media.
- ▶ Safely purge toxic process media via an exhaust line.
- ▶ Use appropriate filter equipment to separate toxic process media.

⚠ WARNING**Risk of poisoning from incorrect use of the gas ballast system**

The gas ballast system of the scroll pump is vacuum sealed only when used in valid, snapped positions "0", "1" and "2". When operating the valves in intermediate stages, there is a risk that process media can escape to the environment uncontrolled. When using toxic process media, there is a risk of poisoning.

- ▶ Change the positions of the valve only for setting the gas ballast stages.
- ▶ Operate the gas ballast valve only in the snap positions.

⚠ WARNING**Mortal danger from electric shock during operation caused by transport damage**

Damage to the transport packaging may favor the ingress of moisture or electrically conductive media into the vacuum pump. Devices connected to the mains may still be live. There is a danger to life from electric shock when making contact with live components.

- ▶ Before commissioning, convince yourself of the trouble-free state of your vacuum pump.
- ▶ Pay attention to residues of fluids or condensate.
- ▶ Do not put the vacuum pump into operation if there is obvious external damage.

⚠ WARNING**Risk of fatal injury due to electric shock caused by water damage**

The device meets protection degree IP 20 according to EN 60529: 2014 and is not protected against water ingress. Vacuum pumps operated on the floor lead to leakage current in penetrating and surrounding water. There is a danger to life from electric shock when making contact with live water.

- ▶ In case of water damage, disconnect the complete power supply from the area affected.
- ▶ Provide an on-site electrical fuse protection (e.g. RCD) in hazardous areas.
- ▶ When selecting the installation location, observe potential damage from water.

⚠ CAUTION

Danger of injury from bursting as a result of high pressure in the exhaust line

Faulty or inadequate exhaust pipes lead to dangerous situations, e.g., increased exhaust pressure. There is a danger of bursting. Injuries caused by flying fragments, the escaping of high pressure, and damage to the unit cannot be excluded.

- ▶ Open shut-off units immediately before or at the same time as starting the pump.
- ▶ Observe the maximum permissible pressure of 1,500 hPa (absolute).
- ▶ Observe the permissible pressures and pressure differentials for the product.
- ▶ Check the function of the exhaust line on a regular basis.

⚠ CAUTION

Danger of cut injuries from access to rotating parts

Transport damage on the air guide hood of the vacuum pump allows access to rotating and sharp edged parts of the fan. Cut injuries from accidental contact are the result.

- ▶ Before commissioning, convince yourself of the trouble-free state of your vacuum pump.
- ▶ Do not put the vacuum pump into operation if there is obvious external damage.

⚠ CAUTION

Risk of injury from burns where hot process gases leak with no exhaust line

During operation with no exhaust line, the vacuum pump allows exhaust gases and vapors to escape freely into the air. For processes with high temperatures, there is a risk of burns on hot exhaust gases.

- ▶ If necessary, safely purge hot process gases via an exhaust line.
- ▶ Wear personal protective equipment if necessary.

Risks during maintenance

⚠ WARNING

Danger to life from electric shock during maintenance and service work

There is a danger to life from electric shock when making contact with live components that still exist after the vacuum pump has been switched off.

- ▶ Disconnect the vacuum pump safely from the mains.
- ▶ Wait until the vacuum pump comes to a standstill (rotation speed = 0).
- ▶ After switching off the vacuum pump, wait another 5 minutes until the capacitors have discharged.

⚠ WARNING

Health hazard through poisoning from toxic contaminated components or devices

Toxic process media result in contamination of devices or parts of them. During maintenance work, there is a risk to health from contact with these poisonous substances. Illegal disposal of toxic substances causes environmental damage.

- ▶ Take suitable safety precautions and prevent health hazards or environmental pollution by toxic process media.
- ▶ Decontaminate affected parts before carrying out maintenance work.
- ▶ Wear protective equipment.

⚠ WARNING**Crushing and cutting danger on unprotected parts from unforeseeable automatic run-up during maintenance.**

During activities on exposed mechanical components, there is a risk of crushing or cut injuries from sudden run-up.

- ▶ Switch off the vacuum pump before any maintenance work and work.
- ▶ Vent the vacuum pump to atmospheric pressure.
- ▶ Disconnect the vacuum pump safely from the mains.
- ▶ Secure the vacuum pump against re-start.
- ▶ Disconnect the mains cable from the vacuum pump.

Risks in the event of malfunctions**⚠ WARNING****Danger to life from electric shock in the event of a fault**

In the event of a fault, devices connected to the mains may be live. There is a danger to life from electric shock when making contact with live components.

- ▶ Always keep the mains connection freely accessible so you can disconnect it at any time.

⚠ CAUTION**Danger of burns on hot surfaces in case of malfunctions**

Failure of the ventilation due to transport damage or disregarded previous damage lead to impermissibly high temperatures. There is a danger of burns by accidental contact. There is a risk of property damage to, and even destruction of the vacuum pump.

- ▶ Disconnect the vacuum pump from the mains.
- ▶ Allow the vacuum pump to cool down before carrying out any maintenance work.
- ▶ Wear personal protective equipment if necessary.

2.3 Safety precautions

**Duty to provide information on potential dangers**

The product holder or user is obliged to make all operating personnel aware of dangers posed by this product.

Every person who is involved in the installation, operation or maintenance of the product must read, understand and adhere to the safety-related parts of this document.

**Infringement of conformity due to modifications to the product**

The Declaration of Conformity from the manufacturer is no longer valid if the operator changes the original product or installs additional equipment.

- Following the installation into a system, the operator is required to check and re-evaluate the conformity of the overall system in the context of the relevant European Directives, before commissioning that system.

General safety precautions when handling the product

- ▶ Observe all applicable safety and accident prevention regulations.
- ▶ Check that all safety measures are observed at regular intervals.
- ▶ Do not expose body parts to the vacuum.
- ▶ Always ensure a secure connection to the earthed conductor (PE).
- ▶ Never disconnect plug connections during operation.
- ▶ Observe the above shutdown procedures.
- ▶ Before working on the vacuum pump, wait until complete standstill (rotation speed $f = 0$).
- ▶ Never put the device into operation with the vacuum connection open.
- ▶ Keep lines and cables away from hot surfaces ($> 70^{\circ}\text{C}$).
- ▶ Never fill or operate the unit with cleaning agents or cleaning agent residues.

- ▶ Do not carry out your own conversions or modifications on the unit.
- ▶ Observe the unit's protection degree prior to installation or operation in other environments.

2.4 Limits of use of the product

Installation location	<ul style="list-style-type: none"> • Indoors, protected against: <ul style="list-style-type: none"> – dust deposits – falling objects – fire-fighting water • Outdoors, protected against: <ul style="list-style-type: none"> – falling objects – direct influence of weather such as rain, splash water, strong drafts and sunlight – fire-fighting water – lightning strike
Air pressure	750 hPa to 1060 hPa
Installation altitude	max. 2500 m
Recommended constant intake pressure	200 hPa ¹⁾
Recommended tank size for pumping out atmospheric pressure	<ul style="list-style-type: none"> • HiScroll 6: 30 l • HiScroll 12: 60 l • HiScroll 18: 80 l
Installation surface flatness	±10 %
Rel. air humidity	max. 90 %, non-condensing
Ambient temperature	5 °C to 40 °C
Transport temperature	-25 °C to 55 °C
Storage temperature	-10 °C to 50 °C
Protection class	I
Excess voltage category	II
Permissible protection degree	IP20 Housing type: NEMA Type 1 (according to UL 50E)
Degree of contamination	2

Tbl. 3: Permissible ambient conditions

2.5 Proper use

- ▶ Use the scroll pump only for generating vacuum.
- ▶ Use the scroll pump only in closed indoor areas.
- ▶ Use the scroll pump for the evacuation of dry and inert gases.
- ▶ Use the scroll pump with gas ballast to evacuate moist gases.

2.6 Foreseeable improper use

Improper use of the product invalidates all warranty and liability claims. Any use that is counter to the purpose of the product, whether intentional or unintentional, is regarded as misuse.

- Transport, installation or operation of the vacuum pump in an impermissible spatial position
- Establishing the voltage supply without correct installation
- Connection of the vacuum pump to suitable operating voltages
- Pumping of explosive media
- Pumping of corrosive media
- Pumping of dust
- Pumping of fluids
- Operation with impermissible high gas throughput
- Operation with impermissible gas ballast quantities
- Operation with impermissibly set stages of the gas ballast valve
- Operation with excessive irradiated heat output

1) Higher permanent intake pressures can lead to increased wear

- Operation with impermissibly high exhaust pressure
- Operation in impermissible high magnetic fields
- Use for pressure generation
- Use in areas with ionizing radiation
- Use in potentially explosive areas
- Use in systems in which sporadic loads and vibrations or periodic forces act on the device
- Use of accessories or spare parts that are not listed in these instructions
- Separation, replacement or reuse of the electronic drive unit.

2.7 Personnel qualification

The work described in this document may only be carried out by persons who have appropriate professional qualifications and the necessary experience or who have completed the necessary training as provided by Pfeiffer Vacuum.

Training people

1. Train the technical personnel on the product.
2. Only let personnel to be trained work with and on the product when under the supervision of trained personnel.
3. Only allow trained technical personnel to work with the product.
4. Before starting work, make sure that the commissioned personnel have read and understood these operating instructions and all applicable documents, in particular the safety, maintenance and repair information.

2.7.1 Ensuring personnel qualification

Specialist for mechanical work

Only a trained specialist may carry out mechanical work. Within the meaning of this document, specialists are people responsible for construction, mechanical installation, troubleshooting and maintenance of the product, and who have the following qualifications:

- Qualification in the mechanical field in accordance with nationally applicable regulations
- Knowledge of this documentation

Specialist for electrotechnical work

Only a trained electrician may carry out electrical engineering work. Within the meaning of this document, electricians are people responsible for electrical installation, commissioning, troubleshooting, and maintenance of the product, and who have the following qualifications:

- Qualification in the electrical engineering field in accordance with nationally applicable regulations
- Knowledge of this documentation

In addition, these individuals must be familiar with applicable safety regulations and laws, as well as the other standards, guidelines, and laws referred to in this documentation. The above individuals must have an explicitly granted operational authorization to commission, program, configure, mark, and earth devices, systems, and circuits in accordance with safety technology standards.

Trained individuals

Only adequately trained individuals may carry out all works in other transport, storage, operation and disposal fields. Such training must ensure that individuals are capable of carrying out the required activities and work steps safely and properly.

2.7.2 Personnel qualification for maintenance and repair



Advanced training courses

Pfeiffer Vacuum offers advanced training courses to maintenance levels 2 and 3.

Adequately trained individuals are:

- **Maintenance level 1**
 - Customer (trained specialist)
- **Maintenance level 2**
 - Customer with technical education
 - Pfeiffer Vacuum service technician
- **Maintenance level 3**
 - Customer with Pfeiffer Vacuum service training
 - Pfeiffer Vacuum service technician

2.7.3 Advanced training with Pfeiffer Vacuum

For optimal and trouble-free use of this product, Pfeiffer Vacuum offers a comprehensive range of courses and technical trainings.

For more information, please contact [Pfeiffer Vacuum technical training](#).

3 Product description

3.1 Function

The Pfeiffer Vacuum scroll pump is a vacuum pump operating dry in a suction chamber for generating a coarse or medium vacuum according to the physical pumping principle of a spiral vacuum pump. The pump is equipped with an integrated drive and control unit. A three-stage gas ballast system supports the prevention of condensation accumulating in the vacuum pump.

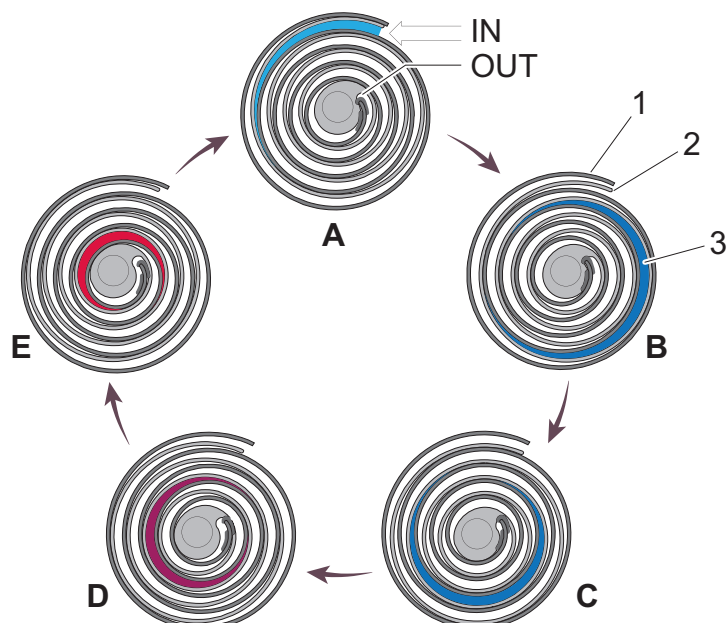

Fig. 2: Schematic compression cycle of scroll pumps

IN	Gas inlet	2	Orbiting spiral
OUT	Gas outlet	3	Gas compression
1	Stationary spiral	A bis E	Sections of increasing compression in the pumping cycle

Spiral vacuum pumps comprise a stationary and orbiting spiral. Varying cavities are generated at the pump inlet by the movements of the orbiting spiral, which suck in the gas. The movement of the rotor compresses the gas continuously until being expelled into the atmosphere at the pump outlet. The suction chamber is completely free from lubricants.

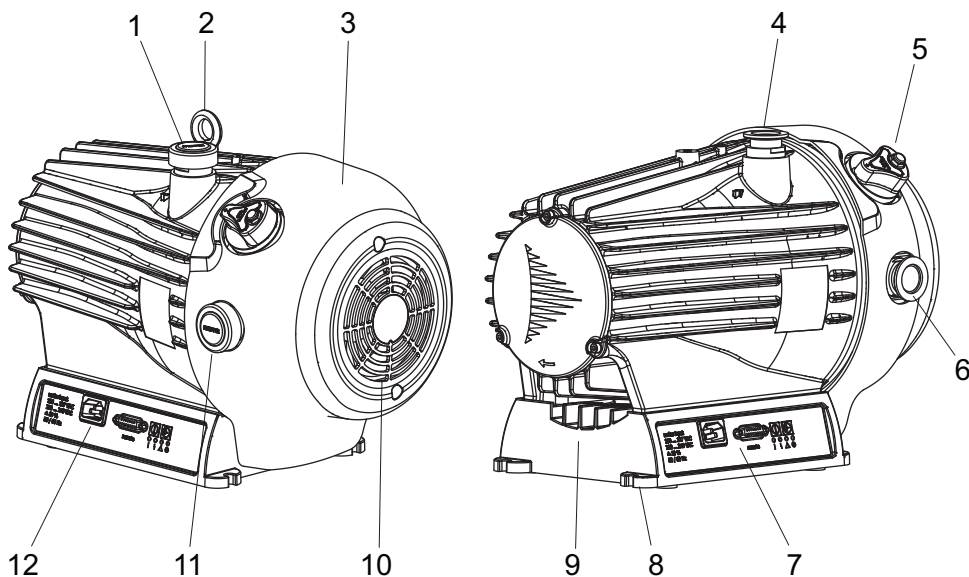

Fig. 3: HiScroll design

- | | |
|--|---|
| 1 Protective cover for DN 25 vacuum connection | 7 Interfaces of the electronic drive unit |
| 2 Eye bolt | 8 Mounting hole |
| 3 Air guide hood | 9 Base |
| 4 Vacuum connection | 10 Fan |
| 5 Gas ballast valve | 11 Protective cover for DN 25 exhaust |
| 6 Exhaust connection | 12 Mains supply plug |

3.1.1 Drive

The vacuum pump is equipped with a highly efficient synchronous motor with sensor-free control, in accordance with the patented INFORM procedure according to Prof. Schrödl.

The integrated electronic drive unit permits the control and monitoring of pumping functions via the "remote" interface using a display and control panel.

3.1.2 Cooling

- Air cooling

The electronic drive unit regulates the cooling capacity of the integrated fan depending on the cooling requirement.

3.1.3 Shaft bearing

Ball bearing-mounted eccentric shaft. The dry running working chamber of the vacuum pump is separated hermetically from the shaft bearing.

- 2 x deep groove ball bearings, maintenance-free





3.1.4 Gas ballast

An integrated gas ballast system serves the controlled supply of ambient air or inert gas into the suction chamber. Gas ballast supports the reduction of condensate accumulating in the pumping system.

3.1.5 Pressure sensor

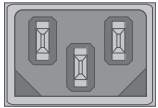
The vacuum pump is equipped with a pressure sensor in the pumping system, either directly or by way of installation (optional accessory). The digital Piezo/Pirani sensor RPT 010 measures the intake pressure of the vacuum pump. Certain functions described for the vacuum pump are only available with a pressure sensor installed.

3.2 Connections

Connection	Description
	mains input Housing connector C13 for the voltage supply
	remote D-sub socket with 15 pins for configuration and connection of a remote control.
	Stand-by button Pressing this button activates or deactivates the stand-by mode of the vacuum pump. Corresponds with parameter [P:002] . ²⁾
	On/Off button Switches the vacuum pump and all components connected on or off, depending on their configuration. Corresponds with parameter [P:010] . ³⁾

Tbl. 4: Interfaces of the electronic drive unit

3.3 Identifying the product

- ▶ To ensure clear identification of the product when communicating with Pfeiffer Vacuum, always keep all of the information on the rating plate to hand.
- ▶ Learn about certifications through test seals on the product or at www.certipedia.com with company ID no. 000021320.

3.4 Product features

Version	Nominal pumping speed
HiScroll 12, Scroll Pump, Standard	12.1 m ³ /h
HiScroll 12, Scroll Pump, Standard, incl. pressure sensor	12.1 m ³ /h
HiScroll 18, Scroll Pump, Standard	18.1 m ³ /h
HiScroll 18, Scroll Pump, Standard, incl. pressure sensor	18.1 m ³ /h

Tbl. 5: Features of scroll pumps

3.5 Scope of delivery

- Scroll pump with electronic drive unit
- Protective cap for vacuum connection
- Protective cover for the exhaust connection
- Operating instructions

2) Additional functions: (see chapter "Speed modes", page 41)

3) Additional functions: (see chapter "Operating modes", page 40)

4 Transportation and Storage

4.1 Transporting the vacuum pump

⚠ WARNING

Risk of serious injury from swinging, toppling or falling objects

During transport, there is a risk of crushing and impact on swinging, toppling or falling objects. There is a risk of injuries to limbs, up to and including bone fractures and head injuries.

- ▶ Secure the danger zone if necessary.
- ▶ Pay attention to the center of gravity of the load during transport.
- ▶ Ensure even movements and moderate speeds.
- ▶ Observe safe handling of the transport devices.
- ▶ Avoid sloping attachment aids.
- ▶ Never stack products.
- ▶ Wear protective equipment, e.g. safety shoes.



Packing

We recommend keeping the transport packaging and original protective cover.

General information regarding safe transport

1. Observe weight specified on the rating plate.
2. Wherever possible, always transport or ship the vacuum pump in its original packaging.
3. Remove the protective cover only immediately prior to installation.

Information regarding transport of the vacuum pump in its packaging

1. Use a pallet truck to transport the vacuum pump in its packaging.
2. Note the center of gravity of the load.
3. Observe safe handling of manually operated transport devices.
4. Ensure harmonious movements and moderate speeds.
5. Pay attention to level ground.
6. Wear protective equipment, e.g. safety shoes.

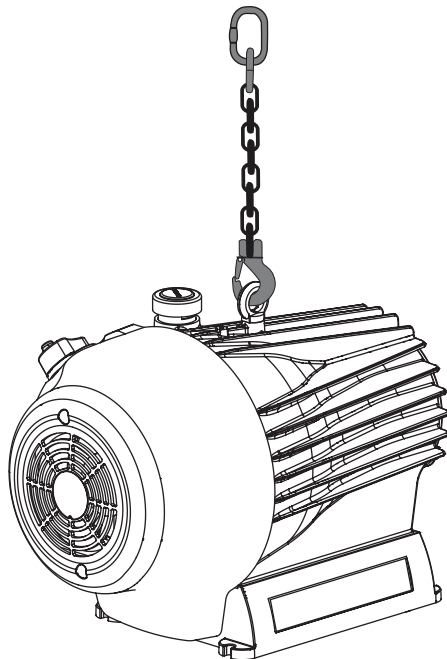

Fig. 4: Slinging points for transport of the scroll pump

Information for transport of the vacuum pump without packaging

1 eye bolt is included in the scope of delivery. It is securely bolted to the vacuum pump at the factory.

1. Attach suitable lifting tools to the eye bolt.
2. Pay attention to the correct use and fastening of the lifting equipment.
3. Lift the vacuum pump vertically (e.g. out of the packaging).
4. Remove the eye bolt following transport and installation as required.
 - Keep the eye bolt for future use.

4.2 Storing the vacuum pump

**Packing**

We recommend storing the product in its original packaging.

Storing the scroll pump

1. Close all flange openings with the original protective caps.
2. Close the gas ballast valve (position "0").
3. Store the vacuum pump only indoors within the permissible temperature limits.
4. In rooms with humid or aggressive atmospheres: Hermetically seal the vacuum pump together with a drying agent in a plastic bag.

5 Installation

5.1 Set up the vacuum pump

⚠ WARNING

Risk of fatal injury due to electric shock caused by water damage

The device meets protection degree IP 20 according to EN 60529: 2014 and is not protected against water ingress. Vacuum pumps operated on the floor lead to leakage current in penetrating and surrounding water. There is a danger to life from electric shock when making contact with live water.

- ▶ In case of water damage, disconnect the complete power supply from the area affected.
- ▶ Provide an on-site electrical fuse protection (e.g. RCD) in hazardous areas.
- ▶ When selecting the installation location, observe potential damage from water.

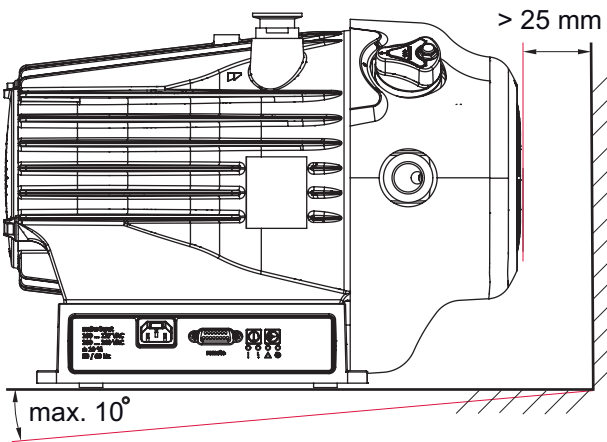

Fig. 5: Minimum clearances and permissible inclination

Procedure

- ▶ Place the vacuum pump on a flat, horizontal surface.
- ▶ Always keep the connections and manual control elements freely accessible.
- ▶ Keep the specifications on the motor rating plate visible and freely accessible.
- ▶ With stationary installation, if necessary, secure the vacuum pump on the standing area with all 4 fixing holes (M8).
- ▶ When installing the pump in a closed housing, ensure adequate air circulation.

5.2 Connecting the vacuum side



Preventing throttling losses

Using short vacuum connection lines with greater nominal diameter prevents throttling losses.



Condensate separator

Pfeiffer Vacuum recommends the installation of a condensate separator in case vapors are formed from moisture during evacuation.

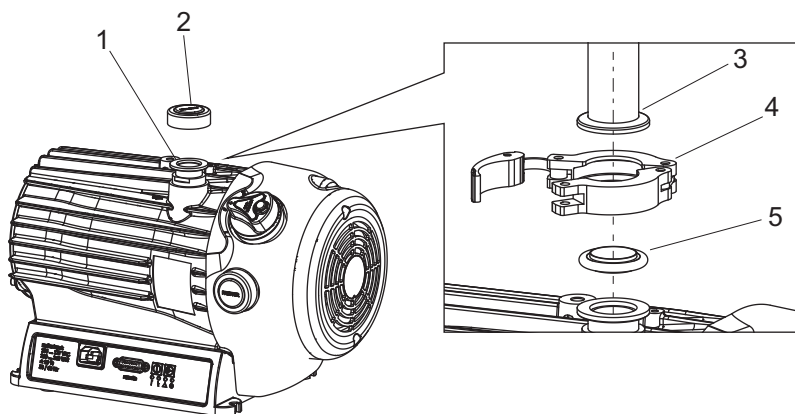

Fig. 6: Example of vacuum connection

- | | |
|--|------------------|
| 1 Vacuum connection of the scroll pump | 4 Circlip |
| 2 Protective cover | 5 Centering ring |
| 3 Vacuum components DN 25 ISO-KF | |

Procedure

1. Take the protective cover off the scroll pump vacuum connection.
2. Install the connection between vacuum pump and vacuum system so that it is as short as possible.
3. Install a vacuum connection with small flange components, e.g. fasteners and pipe components DN 25 ISO-KF from the [Pfeiffer Vacuum Components Shop](#).
4. Connect the vacuum pump to the vacuum system using the vacuum connection.

5.3 Connecting the exhaust side

⚠ WARNING

Danger to life from poisoning where toxic process gases leak with no exhaust line

During normal operation, the vacuum pump expels exhaust gases and vapors freely into the air. In processes involving toxic media, there is a risk of injury and danger to life due to poisoning.

- ▶ Observe the relevant regulations for handling toxic substances.
- ▶ Safely purge toxic process gases via an exhaust line.

⚠ CAUTION

Danger of injury from bursting as a result of high pressure in the exhaust line

Faulty or inadequate exhaust pipes lead to dangerous situations, e.g., increased exhaust pressure. There is a danger of bursting. Injuries caused by flying fragments, the escaping of high pressure, and damage to the unit cannot be excluded.

- ▶ Open shut-off units immediately before or at the same time as starting the pump.
- ▶ Observe the maximum permissible pressure of 1,500 hPa (absolute).
- ▶ Observe the permissible pressures and pressure differentials for the product.
- ▶ Check the function of the exhaust line on a regular basis.



Condensate separator

Pfeiffer Vacuum recommends installing a condensate separator, with condensate drain at the lowest point of the exhaust line.

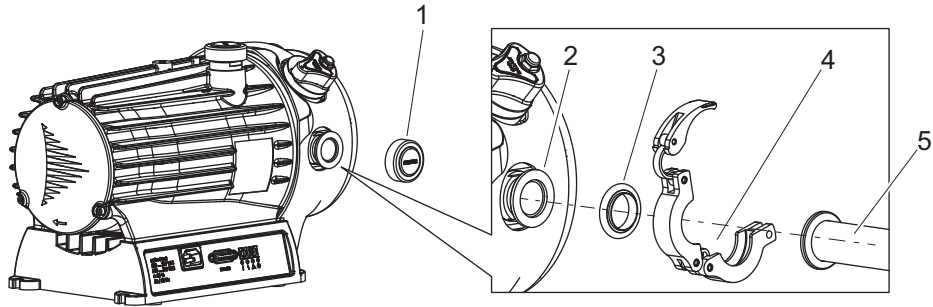

Fig. 7: Example of exhaust connection

- | | |
|---|----------------------------------|
| 1 Protective cover | 4 Circlip |
| 2 Exhaust connection of the scroll pump | 5 Vacuum components DN 25 ISO-KF |
| 3 Centering ring | |

Procedure

1. Remove the protective cover from the exhaust connection.
2. Choose a minimum exhaust line cross section equal to the connection nominal diameter.
3. Install a vacuum connection with small flange components, e.g. fasteners and pipe components DN 25 ISO-KF from the [Pfeiffer Vacuum Components Shop](#).
4. Route the piping downwards from the vacuum pump, to prevent condensate return.
5. Support or suspend the piping to the vacuum pump so that no piping system forces act on the vacuum pump.

5.4 Connecting the gas ballast external supply

NOTICE

Risk of damage from condensation in vacuum pump

Exceeding the saturation vapor pressure of process media during the compression phase leads to condensation in the suction chamber. This results in an increase of the achievable ultimate pressure and to a general deterioration of the performance data of the vacuum pump as a whole. Corrosion and contamination impair service life.

- ▶ Use the gas ballast.
- ▶ Supply dry room air or inert gas in order to increase the vapor capacity of the process medium.
- ▶ Pump condensable vapors only when the vacuum pump is warm and the gas ballast valve open.
- ▶ Operate the vacuum pump with gas ballast a further approx. 30 minutes after finishing the process in order to dissipate any residual moisture.

The gas ballast system of the scroll pump is suitable for being connected to a gas external supply. Couplings for the G 1/8" connection from the Pfeiffer Vacuum accessories range are available for this purpose.

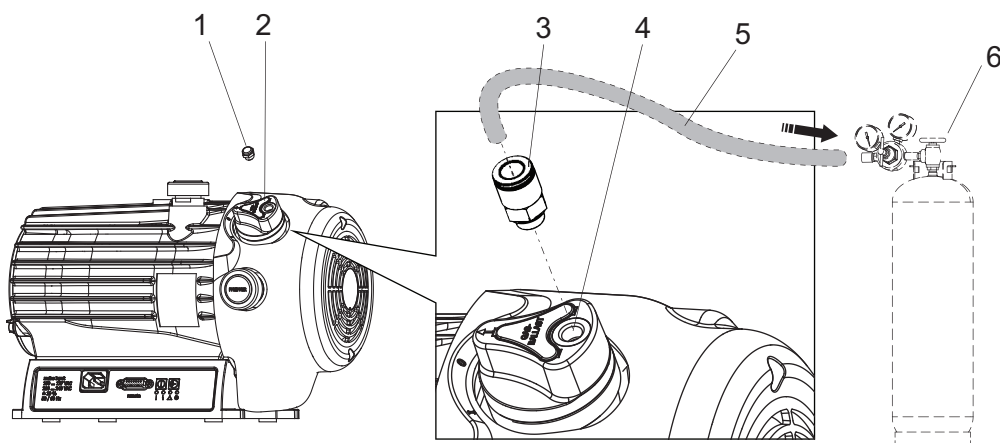

Fig. 8: Connecting the gas ballast external supply

- | | |
|----------------------------------|----------------------------------|
| 1 Sinter filter | 4 Gas ballast connection opening |
| 2 Gas ballast valve | 5 External gas supply line |
| 3 Example of connecting coupling | 6 External gas supply |

Required tools

- Wrench, **WAF 13**
- Calibrated torque wrench (tightening factor ≤ 1.6)

Connecting the gas supply

1. Turn the gas ballast valve to position "0".
2. Unscrew the sinter filter the from valve housing.
3. Screw a connecting coupling with sealing ring into the G 1/8" filter bore.
 - Tightening torque: **2.5 Nm**
4. Connect an external supply with nitrogen (N_2) or another dry, inert gas to the coupling.
5. With the gas supply, observe the maximum permissible inlet pressure.

5.5 Establishing the mains connection

⚠ DANGER

Danger to life from electric shock

Inadequate or incorrect grounding of the unit leads to contact-sensitive voltage on the housing. When making contact, increased leakage currents will cause a life-threatening electric shock.

- ▶ Before the installation, check that the connection leads are voltage-free.
- ▶ Conduct the electrical connection in accordance with locally applicable regulations.
- ▶ Make sure that the local mains voltage and frequency match rating plate specifications.
- ▶ Make sure that the mains cable and extension cable meet the requirements for double isolation between input voltage and output voltage, in accordance with IEC 61010 and IEC 60950.
- ▶ Use only a 3-pin mains cable and extension cable with properly connected protective earthing (earthed conductor).
- ▶ Plug the mains plug into a socket with earthing contact only.
- ▶ Always connect the mains cable prior to all other cables, to ensure continuous protective earthing.

⚠ WARNING

Risk of fatal injury due to electric shock on account of incorrect installation

The device's power supply uses life-threatening voltages. Unsafe or improper installation can lead to life-threatening situations from electric shocks obtained from working with or on the unit.

- ▶ Ensure safe integration into an emergency off safety circuit.
- ▶ Do not carry out your own conversions or modifications on the unit.

⚠ WARNING

Risk of fatal injury due to electric shock caused by water damage

The device meets protection degree IP 20 according to EN 60529: 2014 and is not protected against water ingress. Vacuum pumps operated on the floor lead to leakage current in penetrating and surrounding water. There is a danger to life from electric shock when making contact with live water.

- ▶ In case of water damage, disconnect the complete power supply from the area affected.
- ▶ Provide an on-site electrical fuse protection (e.g. RCD) in hazardous areas.
- ▶ When selecting the installation location, observe potential damage from water.

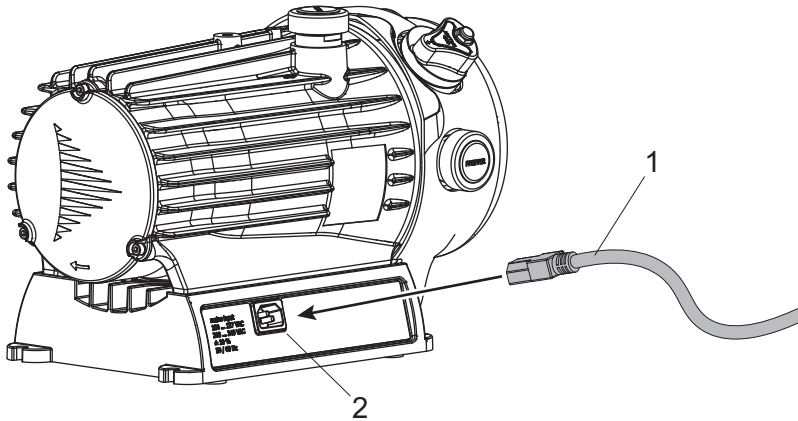

Fig. 9: Establishing mains connection

- 1 Country-specific power supply cable (not included in scope of delivery)
- 2 Mains plug of the electronic drive unit ACin

i **Mains supply**
 The electronic drive unit starts together with the connection of the voltage supply.

Establishing the mains supply

1. Order a corresponding mains connection cable from the Pfeiffer Vacuum accessories range.
2. Always ensure a secure connection to the earthed conductor (PE).
3. Plug the mains cable into the connecting plug of the electronic drive unit.

6 Interfaces

6.1 Interface overview

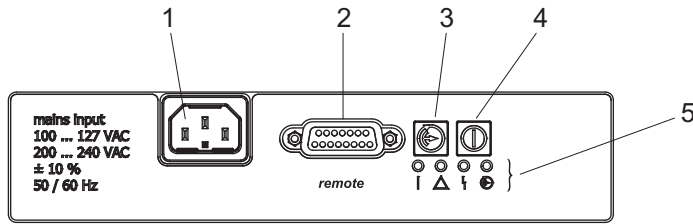

Fig. 10: Interfaces of the electronic drive unit

- | | |
|-------------------------|------------------------------|
| 1 Mains connection ACIn | 4 On/Off button |
| 2 Remote connection | 5 LED operating mode display |
| 3 Stand-by button | |

6.2 "Remote" interface

The 15-pin sub-D connection with the "remote" designation offers the possibility to operate the electronic drive unit via remote control. The following specifications are the factory settings for the electronic drive unit. They can be configured with the Pfeiffer Vacuum parameter set.

► Utilize the screened plug and cable.

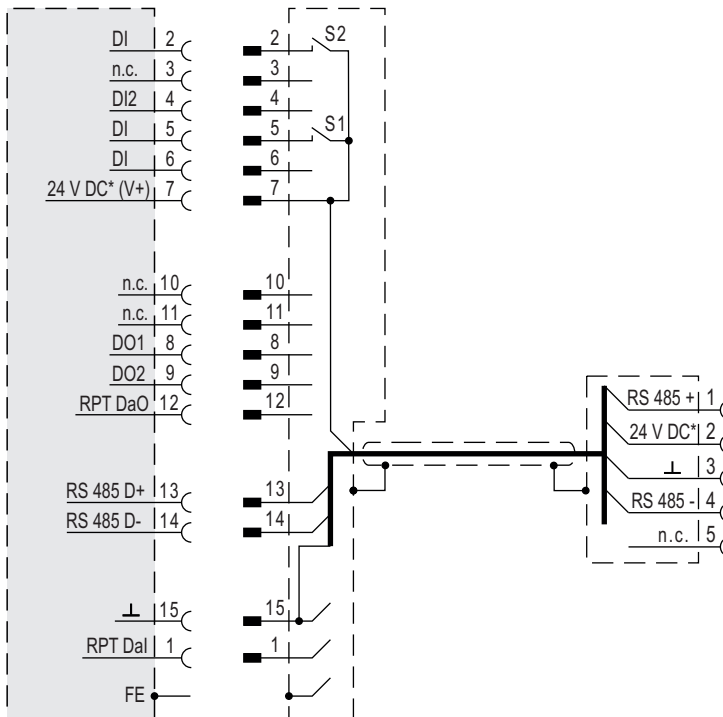

Fig. 11: Connection diagram of 15-pin "remote" connection

Pin	Assignment	Description, factory setting
1		RPT 010 com in For internal use only
2	DI remote priority	Operation via "remote" interface
3	unassigned	
4	DI2	open: off; V+: on
5	DI Pumping station	open: off; V+: on and malfunction acknowledgment
6	DI Standby	open: Standby off, V+: Standby on
7	+24 V DC* output (V+)	Reference voltage for all digital inputs (5 W max.)
8	DO1	GND: no, V+: yes ($I_{max} = 50 \text{ mA}/24 \text{ V}$), function can be selected via parameters
9	DO2	GND: no, V+: yes ($I_{max} = 50 \text{ mA}/24 \text{ V}$), function can be selected via parameters
10	unassigned	
11	unassigned	
12		RPT 010 com out For internal use only
13	RS-485	D+
14	RS-485	D-
15	Ground (GND)	Reference earth for all digital inputs and outputs

Tbl. 6: Terminal lay-out of 15-pin "remote" connection

6.2.1 Inputs

The digital inputs at the "remote" connection are used to switch various electronic drive unit functions. Inputs are assigned with functions ex-factory. You can configure them via the RS-485 interface and the Pfeiffer Vacuum parameter set.

DI remote priority/pin 2

V+: The "remote" connection has control priority over all other control sources.

open: Remote priority inactive

DI/Pin 4

V+: On

open: Off

DI pumping station/pin 5

V+: Pumping station on and malfunction acknowledgment.
Reset pending error messages after eliminating the cause.

open: Pumping station off

DI standby/pin 6

V+: Standby on

open: Operation at nominal rotation speed or selected rotation speed in rotation speed setting mode

6.2.2 Outputs

The digital outputs at the "remote" connection have a maximum load limit of 24 V/50 mA per output. You can configure all listed outputs with the Pfeiffer Vacuum parameter set via the RS-485 interface (description relates to factory settings).

DO1/Pin 8

Active high yes

GND no

DO2/Pin 9

Active high yes

GND no

6.2.3 RS-485

Pin 13 and pin 14

You can connect a Pfeiffer Vacuum display and control unit (DCU or HPU) or an external PC via pin 13 and pin 14 on the D-sub connection of the electronic drive unit.

6.3 Connection options

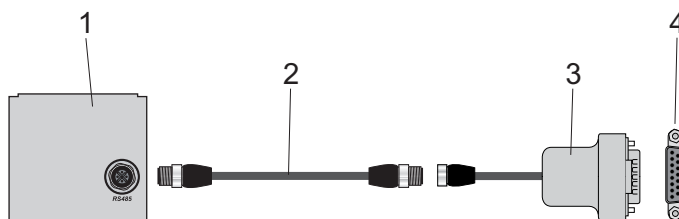

Fig. 12: Connecting a display and control unit via “remote”

- 1 DCU 002 display and control unit
- 2 M12 to M12 extension cable
- 3 RS-485 to M12 connection cable
- 4 "remote" connection

Connecting display and control units

- ▶ Use the connection cable from the control unit scope of delivery or from the accessories program.
- ▶ Install the connection cable between the “remote” connection of the vacuum pump and the “RS-485” connection of the display and control unit.
 - Tightening torque: **0.4 Nm**
- ▶ Always connect the RS-485 interface to one external operating device only.

6.4 Interface RS-485

⚠ DANGER

Danger to life from electric shock

When establishing the voltages that exceed the specified safety extra-low voltage (according to IEC 60449 and VDE 0100), the insulating measures will be destroyed. There is a danger to life from electric shock at the communication interfaces.

- ▶ Connect only suitable devices to the bus system.

The interface with the designation “RS-485” is intended for the connection of a Pfeiffer Vacuum display and control unit (DCU or HPU) or an external computer. The connections are galvanically safe and are isolated from the maximum supply voltage for the electronic drive unit.

Designation	Value
Serial interface	RS-485
Baudrate	9600 Baud
Data word length	8 bit
Parity	none (no parity)
Start bits	1
Stop bits	1

Tbl. 7: Features of the RS-485 interface

Connecting a Pfeiffer Vacuum display and control units or PC

- ▶ Use the connection cable from the control unit scope of delivery or from the accessories program.
- ▶ You can connect one external control unit to the RS-485 interface.
- ▶ You can connect a USB interface (PC) via the USB/RS-485 converter.

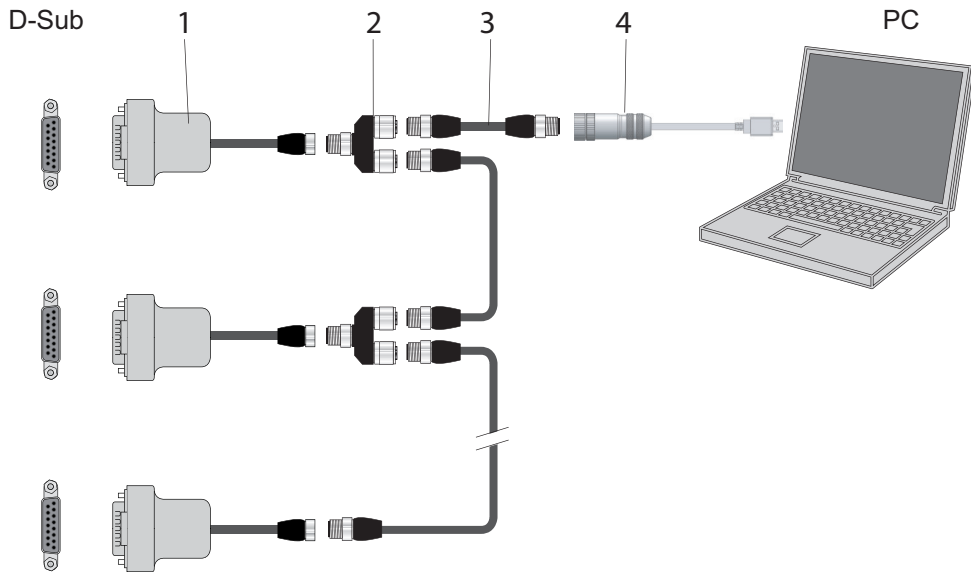

Fig. 13: Cross-link via connection RS-485 using connection cables and accessories

- | | |
|--------------------------------|------------------------------|
| 1 Connection cable with RS-485 | 3 M12 to M12 extension cable |
| 2 Y-connector for RS-485 | 4 USB RS-485 converter |



Networking as RS-485 bus

The group address of the electronic drive unit is 902.

1. Install the devices according to the specification for RS-485 interfaces.
2. Make sure that all devices connected to the bus have different RS-485 device addresses [P:797].
3. Connect all devices to the bus with RS-485 D+ and RS-485 D-.

6.5 Pfeiffer Vacuum protocol for RS-485 interface

6.5.1 Telegram frame

The telegram frame of the Pfeiffer Vacuum protocol contains only ASCII code characters [32; 127], the exception being the end character of the telegram C_R . Basically, a master  (e.g. a PC) sends a telegram, which a slave  (e.g. electronic drive unit or gauge) responds to.

a2	a1	a0	*	0	n2	n1	n0	l1	l0	dn	...	d0	c2	c1	c0	C_R
a2 – a0				Unit address for slave 												
				<ul style="list-style-type: none"> • Individual address of the unit ["001";"255"] • Group address "9xx" for all identical units (no response) • Global address "000" for all units on the bus (no response) 												
*				Action according to telegram description												
n2 – n0				Pfeiffer Vacuum parameter numbers												
l1 – l0				Data length dn to d0												
dn – d0				Data in the respective data type (see chapter "Data types", page 33).												
c2 – c0				Checksum (sum of ASCII values of cells a2 to d0) modulo 256												
C_R				carriage return (ASCII 13)												

6.5.2 Telegram description

Data query  -->  ?

a2	a1	a0	0	0	n2	n1	n0	0	2	=	?	c2	c1	c0	c _R
----	----	----	---	---	----	----	----	---	---	---	---	----	----	----	----------------

Control command  -->  !

a2	a1	a0	1	0	n2	n1	n0	l1	l0	dn	...	d0	c2	c1	c0	c _R
----	----	----	---	---	----	----	----	----	----	----	-----	----	----	----	----	----------------

Data response / Control command understood  --> 

a2	a1	a0	1	0	n2	n1	n0	l1	l0	dn	...	d0	c2	c1	c0	c _R
----	----	----	---	---	----	----	----	----	----	----	-----	----	----	----	----	----------------

Error message  --> 



a2	a1	a0	1	0	n2	n1	n0	0	6	N	O	_	D	E	F	c2	c1	c0	c _R
										_	R	A	N	G	E				
										_	L	O	G	I	C				

- NO_DEF Parameter number n2–n0 no longer exists
- _RANGE Data dn–d0 outside the permissible range
- _LOGIC Logical access error

6.5.3 Telegram example 1



Data query

Current rotation speed (parameter [P:309], device address slave: "123")

 -->  ?	1	2	3	0	0	3	0	9	0	2	=	?	1	1	2	c _R
ASCII	49	50	51	48	48	51	48	57	48	50	61	63	49	49	50	13

Data response: 633 Hz



Current rotation speed (parameter [P:309], device address Slave: "123")

 --> 	1	2	3	1	0	3	0	9	0	6	0	0	0	6	3	3	0	3	7	c _R
ASCII	49	50	51	49	48	51	48	57	48	54	48	48	48	54	51	51	48	51	55	13

6.5.4 Telegram example 2



Control command

Switch on the pumping station (parameter [P:010], device address Slave: "042")

 -->  !	0	4	2	1	0	0	1	0	0	6	1	1	1	1	1	1	0	2	0	c _R
ASCII	48	52	50	49	48	48	49	48	48	54	49	49	49	49	49	49	48	50	48	13

Control command understood

Switch on the pumping station (parameter [P:010], device address Slave: "042")

 --> 	0	4	2	1	0	0	1	0	0	6	1	1	1	1	1	1	0	2	0	c _R
ASCII	48	52	50	49	48	48	49	48	48	54	49	49	49	49	49	49	48	50	48	13

6.5.5 Data types

No.	Data type	Description	Length l1 – l0	Example
0	boolean_old	Logical value (false/true)	06	000000 is equivalent to false 111111 is equivalent to true
1	u_integer	Positive whole number	06	000000 to 999999

No.	Data type	Description	Length I1 – I0	Example
2	u_real	Positive fixed point number	06	001571 corresponds with 15.71
3	u_expo	Positive exponential number	06	1.2E-2 is equivalent to $1,2 \cdot 10^{-2}$ 005E8 is equivalent to $5 \cdot 10^8$
4	string	Any character string with 6 characters. ASCII codes between 32 and 127	06	TC_110, TM_700
6	boolean_new	Logical value (false/true)	01	0 is equivalent to false 1 is equivalent to true
7	u_short_int	Positive whole number	03	000 to 999
10	u_expo_new	Positive exponential number. The last of both digits are the exponent with a deduction of 20.	06	100023 is equivalent to $1,0 \cdot 10^3$ 100000 is equivalent to $1,0 \cdot 10^{-20}$
11	string16	Any character string with 16 characters. ASCII codes between 32 and 127	16	this-is-an-example
12	string8	Any character string with 8 characters. ASCII codes between 32 and 127	08	Example

7 Parameter set

7.1 General

Important settings and function-related characteristics are factory-programmed into the electronic drive unit as parameters. Each parameter has a three-digit number and a description. The use of the parameter is possible via Pfeiffer Vacuum displays and control panels, or externally via RS-485 using Pfeiffer Vacuum protocol.

The vacuum pump starts in standard mode with factory default pre-set parameters.



Non-volatile data storage











When switching off or in the event of unintentional voltage drop, the **parameters** and the operating hours stay saved in the electronics.

#	Three digit number of the parameter
Display	Display of parameter description
Description	Brief description of the parameters
Functions	Function description of the parameters
Data type	Type of formatting of the parameter for the use with the Pfeiffer Vacuum protocol
Access type	R (read): Read access; W (write): Write access
Unit	Physical unit of the described variable
min. / max.	Permissible limit values for the entry of a value
default	Factory default pre-setting (partially pump-specific)
	The parameter can be saved persistently in the electronic drive unit

Tbl. 8: Explanation and meaning of the parameters



7.2 Control commands

#	Display	Designations	Functions	Data type	Access type	Unit	min.	max.	de-fault	
002	Standby	Standby	0 = off 1 = on	0	RW		0	1	0	✓
006	Auto stdby	automatic standby	0 = off 1 = on	0	RW		0	1	0	✓
009	ErrorAckn	Malfunction acknowledgement	1 = Malfunction acknowledgement	0	W		1	1		
010	PumpgStatn	Pumping station	0 = off 1 = on and malfunction acknowledgement	0	RW		0	1	0	✓
011	Auto boost	automatic boost operation	0 = off 1 = on	0	RW		0	1	0	✓
019	Cfg DO2	Output DO2 configuration	1 = No error 2 = Error 5 = Set rotation speed reached 6 = Pump on 9 = Always "0" 10 = Always "1" 11 = Remote priority active 21 = Gas ballast	7	RW		0	21	5	✓

#	Display	Designations	Functions	Data type	Access type	Unit	min.	max.	de-fault	
020	PressMode	Pressure regulation	0 = off 1 = on	0	RW		0	1	0	
024	Cfg DO1	Output DO1 configuration	0 = Switch-point reached 1 = No error 2 = Error 5 = Set rotation speed reached 6 = Pump on 9 = Always "0" 10 = Always "1" 11 = Remote priority active 21 = Gas ballast	7	RW		0	21	21	
026	SpdSet-Mode	Speed actuator operation	0 = off 1 = on	7	RW		0	1	0	
034	Auto start	automatic start after power failure	0 = off 1 = on	0	RW		0	1	0	
052	BalGasValv	Gas ballast valve control	0 = off 1 = on	0	RW		0	1	0	
060	CtrlVialnt	Operate via interface	1 = remote 2 = RS-485 255 = Unlock interface selection	7	RW		1	255	1	
061	IntSelLckd	Interface selection locked	0 = off 1 = on	0	RW		0	1	0	
063	Cfg DI2	Configuration input DI2	0 - 4 = Deactivated 5 = Speed actuator operation On	7	RW		0	5	0	
095	FactorySet	Factory settings	1 = Reset to factory configuration	0	RW		0	1	0	

Tbl. 9: Control commands

7.3 Status requests

#	Display	Designations	Functions	Data type	Access type	Unit	min.	max.	de-fault	
300	RemotePrio	Remote priority	0 = no 1 = yes	0	R		0	1		
303	Error code	Error code		4	R					
304	OvTempElec	Excess temperature drive electronics	0 = no 1 = yes	0	R		0	1		
305	OvTempPump	Excess temperature pump	0 = no 1 = yes	0	R		0	1		
308	SetRotSpd	Set rotation speed (Hz)		1	R	Hz	0	999999		
309	ActualSpd	Actual rotational speed (Hz)		1	R	Hz	0	999999		
310	DrvCurrent	Drive current		2	R	A	0	9999.99		
311	OpHrsPump	Pump operating hours		1	R	h	0	999999		
312	Fw version	Drive electronics software version		4	R					
313	DrvVoltage	Drive voltage		2	R	V	0	9999.99		

#	Display	Designations	Func-tions	Data type	Access type	Unit	min.	max.	de-fault	
314	OpHrsElec	Drive electronics operating hours		1	R	h	0	999999		✓
315	Nominal Spd	Nominal rotation speed (Hz)		1	R	Hz	0	999999		
316	DrvPower	Drive power		1	R	W	0	999999		
324	TempPwrStg	Final stage temperature		1	R	°C	0	999999		
326	TempElec	Electronics temperature		1	R	°C	0	999999		
346	TempMotor	Motor temperature		1	R	°C	0	999999		
349	ElecName	Electronic drive unit designation		4	R					
360	ErrHist1	Error code history, item 1		4	R					✓
361	ErrHist2	Error code history, item 2		4	R					✓
362	ErrHist3	Error code history, item 3		4	R					✓
397	SetRotSpd	Set rotation speed (rpm)		1	R	rpm	0	999999		
398	ActualSpd	Actual speed (rpm)		1	R	rpm	0	999999		
399	NominalSpd	Nominal rotation speed (rpm)		1	R	rpm	0	999999		

Tbl. 10: Status requests

7.4 Reference value inputs

#	Display	Designations	Func-tions	Data type	Access type	Unit	min.	max.	de-fault	
707	SpdSVal	Setpoint in speed-control operation		2	RW	%	40	100	83	✓
717	StdbySVal	Rotational speed setpoint in standby operation		2	RW	%	40	100	50	✓
730	Press. Set	Switch-on threshold with auto standby / target pressure with pressure regulation		10	RW	hPa	0.01	30.0	10.0	✓
732	Press. Rel	Switch-off threshold with auto standby		10	RW	hPa	1.0	100.0	20.0	✓
739	PrsSn1Name	Name sensor 1		4	R					
740	Pressure 1	Pressure value 1		10	RW	hPa	$1 \cdot 10^{-5}$	1200.0		✓
742	PrsCorrPi 1	Correction factor 1		2	RW		0.1	8.0	-	✓
797	RS485Adr	RS-485 Interface address		1	RW		1	255	2	✓

Tbl. 11: Reference value inputs

7.5 Additional parameter for the DCU



Additional parameter in the control panel

The basic parameter set is set in the electronic drive unit ex-factory. For controlling connected external components (e.g. vacuum measuring instruments), additional parameters (extended parameter set) are available in the corresponding Pfeiffer Vacuum display and control panels.

- Refer to the corresponding operating instructions of the respective components.
- Select the extended parameter set with parameter **[P:794] = 1**.

Parameter set

#	Display	Description	Functions	Data type	Access type	Unit	min.	max.	de-fault	
340	Pressure	Actual pressure value (ActiveLine)		7	R	hPa	$1 \cdot 10^{-10}$	$1 \cdot 10^3$		
350	Ctr Name	Display and control panel: type		4	R					
351	Ctr Software	Display and control panel: software version		4	R					
738	Gauge type	Type of pressure gauge		4	RW					
794	Param set	Parameter set	0 = Basic parameter set 1 = Extended parameter set	7	RW		0	1	0	
795	Servicelin	Insert service line		7	RW				795	

Tbl. 12: Parameter for DCU functions

8 Operation

8.1 Putting the vacuum pump into operation

⚠ WARNING

Danger of poisoning due to toxic process media escaping from the exhaust pipe

During operation with no exhaust line, the vacuum pump allows exhaust gases and vapors to escape freely into the air. There is a risk of injury and fatality due to poisoning in processes with toxic process media.

- ▶ Observe the pertinent regulations for handling toxic process media.
- ▶ Safely purge toxic process media via an exhaust line.
- ▶ Use appropriate filter equipment to separate toxic process media.

⚠ CAUTION

Danger of burns on hot surfaces

Depending on the operating and ambient conditions, the surface temperature of the vacuum pump can increase to above 70 °C.

- ▶ Provide suitable touch protection.

Important settings and function-related variables are programmed ex factory as parameters in the vacuum pump electronic drive unit. Each parameter has a three-digit number and a description. Parameter-driven operation and control is supported via Pfeiffer Vacuum displays and control units, or externally via RS-485 using Pfeiffer Vacuum protocol.

8.2 Switch vacuum pump on

The "Pumping station" parameter **[P:010]** comprises operation of the vacuum pump with control of all connected interfaces and configurations.

Switch on via electronic drive unit

After successfully completing the self-test, the electronic drive unit resets pending and corrected error messages.

1. Switch voltage supply on.
2. Switch the vacuum pump on by pressing the  button once.

Alternative: Switch on via Pfeiffer Vacuum parameters

- ▶ Set parameter **[P:010]** to value of "1".

Alternative: Switch on via "remote" interface

- ▶ Bridge pins 7, 2 and 5.

8.3 Configuring the connections with the Pfeiffer Vacuum parameter set

The electronic drive unit is pre-configured with the factory default basic functions and is ready for operation. For individual requirements, you can configure most connections for the electronic drive unit with the parameter set.

8.3.1 Configuring the digital outputs

Option	Description
0 = Rotation speed switchpoint reached	active, once the switch-point is reached
1 = No error	active, with trouble-free operation
2 = Error	active, if the error message is active
5 = Set rotation speed reached	active, once the set rotation speed switch-point is reached
6 = Pump on	active, if pumping station on, motor on and no error
9 = Always "0"	GND for the control of an external device

Option	Description
10 = Always "1"	+24 V DC for the control of an external device
11 = Remote priority active	active, if the remote priority is active
21 = Fore-vacuum valve, delayed	+24 V DC time-delayed after pumping station on

Tbl. 13: Configure parameters [P:019] and [P:024]

8.3.2 Configure digital inputs

Option	Description
0 - 4 = Deactivated	Connection not operational
5 = Rotation speed mode	Control corresponds to parameter [P:026]

Tbl. 14: Configure parameter [P:063]

8.3.3 Selecting the interfaces

The parameter [P:060] indicates the current selected interface with operating priority. The electronic drive unit only accepts control commands via the interface with operating priority. If the actual setting is not locked by the parameter [P061] = 1, if another interface issues a control command, operating priority is automatically transferred to the other interface.

Option	Description
1 = remote	Operation via connection "remote"
2 = RS-485	Operation via connection "RS-485"
255 = Unlock interface selection	-

Tbl. 15: Parameter [P:060]

8.4 Operating modes

After applying the operating voltage, the electronic drive unit carries out a self-test to check the supply voltage.

The following operating modes are possible:

- Operation without control unit
- Operation via an external control unit
- Operation via RS-485 and Pfeiffer Vacuum display and control unit or PC
- Operation with automatic start

Operation without control unit

1. Provide the current supply.
2. Operate the vacuum pump with the on/off and standby buttons.

Operation via the external control

- ▶ Connect the remote control via the "remote" 15-pin D-Sub socket.



The control is carried out by means of "PLC level".

Operation with peripheral devices DCU, HPU or PC

1. When handling the Pfeiffer Vacuum display and control unit, observe the associated operating instructions:
 - "DCU" operating instructions available from the [Download Center](#).
 - "HPU" operating instructions available from the [Download Center](#).
2. Connect the respective peripheral device to the 15-pin D-Sub socket.
3. Make the desired settings via the RS-485 using the peripheral device.

Operation with auto start function

- ▶ Hold the  button pressed for longer than 5 s.
 - This will edit the parameter [P:034].
 - To confirm the command, the yellow LED flashes for 1 second after releasing the button.

- Parameter **[P:010] = 1**: You press the  button for 5 s and switch off the auto start. **[P:034] = 0**. The vacuum pump itself remains activated. In the event of a return to the mains following a power failure, the vacuum pump remains deactivated.
- Parameter **[P:010] = 0**: You press the  button for 5 s and switch on the auto start. **[P:034] = 1**. The vacuum pump itself remains deactivated. In the event of a return to the mains, the vacuum pump restores the operating status which was established prior to the power failure.

8.5 Speed modes

The vacuum pump has 6 different speed modes.

- General speed modes
 - Normal operation
 - Standby mode
 - Speed actuator operation
- Automatic speed modes
 - Auto boost
 - Auto standby
 - Pressure regulation



Pressure regulation has absolute priority
When pressure regulation is activated, all other speed modes are inactive.

Standby mode has priority over rotation speed setting mode, auto boost and normal operation.

The automatic speed modes are only possible in combination with the connected pressure sensor. Auto boost and auto standby can be combined.

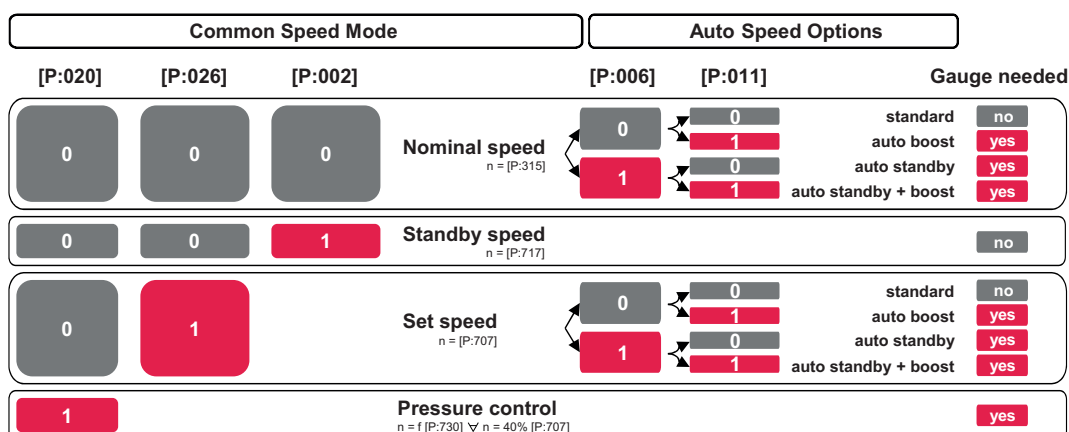

Fig. 14: Speed modes

8.5.1 Normal operation

The vacuum pump starts and operates at nominal rotation speed.

Setting the related parameters

1. Set the parameter **[P:002]** to "0".
2. Set the parameter **[P:026]** to "0".
3. Check the set rotation speed (parameter **[P:308]** or **[P:397]**).

8.5.2 Standby mode

Pfeiffer Vacuum recommends standby mode for during process and production stops. When standby mode is active, the electronic drive unit reduces the rotation speed of the vacuum pump. The factory setting is 50 % of the nominal rotation speed. Stand-by mode has priority over rotation speed setting mode.

Switching on standby mode

- ▶ Press the  button.

Alternative: Standby via Pfeiffer Vacuum parameter

- ▶ Set parameter **[P:002]** to value of "1".

Alternative: Standby via "remote" interface

- ▶ Bridge pins 7 and 6 for DI standby.

Setting the stand-by rotation speed

The vacuum pump has a variable working range from 40 to 100% of the nominal rotation speed.

1. Set the parameter **[P:717]** to the required value in %.
2. Set the parameter **[P:002]** to "1".
3. Check the set rotation speed (parameter **[P:308]** or **[P:397]**).

8.5.3 Speed actuator operation

Rotation speed setting mode reduces the speed and hence the throughput of the vacuum pump. The pumping speed changes proportionally to the rotation speed. Standby has priority over rotation speed setting mode. The specification in rotation speed setting mode **[P:707]** sets the set rotation speed. The rotation speed switch point varies with the set rotation speed.



Permissible rotation speed range

Settings in the rotation speed mode or stand-by mode are subject to the permissible rotation speed range of the respective vacuum pump (technical data). The electronic drive unit adjusts the set rotation speed automatically to the next valid value.

Set the rotation speed setting mode

1. Set the parameter **[P:707]** to the required value in %.
2. Set the parameter **[P:026]** to "1".
3. Check the set rotation speed (parameter **[P:308]** or **[P:397]**).

8.5.4 Auto boost

If a threshold value set at the factory is exceeded, the vacuum pump runs for max. 30 s with 120 % of the current selected set rotation speed and the green LED flickers. The boost mode is then deactivated by the software for 5 mins (recovery time).

Setting the related parameters

1. Set the parameter **[P:011]** to "1".
2. Check the set rotation speed (parameter **[P:308]** or **[P:397]**).
3. Check the actual rotation speed (parameter **[P:309]** or **[P:398]**).

8.5.5 Auto standby

If a specific intake pressure is not reached **[P:730]**, the electronic drive unit automatically reduces the rotation speed. If the intake pressure is exceeded **[P:732]**, the electronic drive unit increases the rotation speed again to the original value. If operating priority is 1 = "remote", auto standby cannot be executed and warning Wrm037 is displayed.

Setting the related parameters

1. Set the parameter **[P:002]** to "0".
2. Set the parameter **[P:006]** to "1".
3. Check the set rotation speed (parameter **[P:308]** or **[P:397]**).

Setting the auto standby rotation speed

1. Set the parameter **[P:717]** to the required value in %.
2. Set the switch-on threshold with parameter **[P:730]**.
3. Set the switch-off threshold with parameter **[P:732]**.
4. Check the set rotation speed (parameter **[P:308]** or **[P:397]**).

Operation with auto standby function

- ▶ Hold the  button pressed for longer than 5 s.
 - This will change the parameter **[P:006]**.
 - To confirm the command, the yellow LED flashes for 1 second after releasing the button.

- Parameter **[P:002] = 1**: You press the \rightarrow button for 5 s and switch off the auto standby. **[P:006] = 0**. The standby pre-selection remains activated.
- Parameter **[P:002] = 0**: You press the \rightarrow button for 5 s and switch off the auto standby. **[P:006] = 1**. The standby pre-selection remains deactivated.

8.6 Pressure regulation operation

Pressure regulation operation is only possible with the pressure sensor connected. The pressure sensor measures the intake pressure. The electronic drive unit varies the rotation speed of the vacuum pump so that the target pressure is adjusted. If the target pressure cannot be reached under the specified conditions (e.g. through higher gas throughput), warning Wrn038 is displayed. The pressure regulation operation is effective in the range between final pressure and 30 hPa.

Setting the related parameters

1. Set the parameter **[P:020]** to "1".
2. Adjust the target pressure using parameter **[P:730]**.

8.7 Determining the effective pressure with calibration factors

The measurement signal of the pressure sensor depends on the type of gas in the Pirani area. The pre-set correction factor = 1 applies for nitrogen (N_2), oxygen (O_2), dry air, and carbon monoxide (CO).

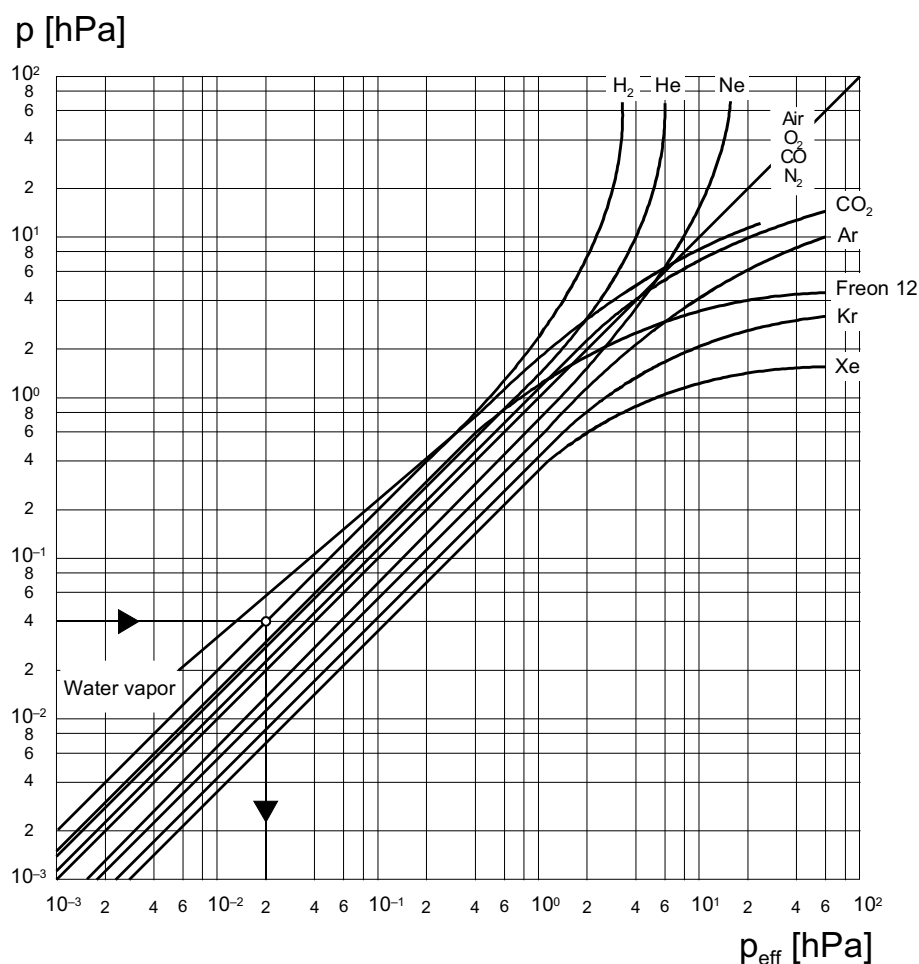

Fig. 15: Displayed pressure

Within the pressure range < 1 hPa, the display is linear.



Gas and vapor mixtures

Process gases are mostly mixtures of gas and vapor. Precise measuring of gas and vapor mixtures is only possible using partial pressure measurement instruments, for example a quadrupole mass spectrometer.

Gas type	Calibration factor (C)
Air, oxygen (O ₂), carbon monoxide (CO), nitrogen (N ₂)	1.0
Hydrogen (H ₂)	0.5
Carbon dioxide (CO ₂)	0.9
Water vapor	0.5
Helium (He)	0.8
Neon (Ne)	1.4
Argon (Ar)	1.7
Krypton (Kr)	2.4
Xenon (Xe)	3.0
Freon 12	0.7

The calibration factors provided are mean values.

Tbl. 16: Calibration factors for the pressure range < 1 hPa

Set calibration factor at electronic drive unit

- ▶ Use [P:742] to enter calibration factor and correct displayed measured value.

Alternatively: Calculate pressure for gases other than air

1. Set the calibration factor in the electronic drive unit to 1.
2. Calculate the effective pressure using the following formula:

$$P_{\text{eff}} = C \times p$$

- P_{eff} = Effective pressure
- C = Calibration factor of the gas to be measured
- p = Displayed pressure (gauge calibrated for air)

8.8 Operation with gas ballast

⚠ WARNING

Risk of poisoning from incorrect use of the gas ballast system

The gas ballast system of the scroll pump is vacuum sealed only when used in valid, snapped positions "0", "1" and "2". When operating the valves in intermediate stages, there is a risk that process media can escape to the environment uncontrolled. When using toxic process media, there is a risk of poisoning.

- ▶ Change the positions of the valve only for setting the gas ballast stages.
- ▶ Operate the gas ballast valve only in the snap positions.

NOTICE

Risk of damage from condensation in vacuum pump

Exceeding the saturation vapor pressure of process media during the compression phase leads to condensation in the suction chamber. This results in an increase of the achievable ultimate pressure and to a general deterioration of the performance data of the vacuum pump as a whole. Corrosion and contamination impair service life.

- ▶ Use the gas ballast.
- ▶ Supply dry room air or inert gas in order to increase the vapor capacity of the process medium.
- ▶ Pump condensable vapors only when the vacuum pump is warm and the gas ballast valve open.
- ▶ Operate the vacuum pump with gas ballast a further approx. 30 minutes after finishing the process in order to dissipate any residual moisture.



Gas flow

The flow rate (gas flow) increases according to inlet pressure.

Vacuum pumps of the HiScroll series are equipped with an integrated mechanically operated two-stage gas ballast valve.

Prerequisites

- Vacuum pump is warm.
- If necessary, an external gas supply is closed.

Procedure

1. If necessary, connect an existing shut-off unit to the vacuum side.
2. Turn the selector switch of the gas ballast valve to the desired position.
 - Allow the selector switch to completely engage in position.
3. In case an external gas supply is used, open the supply.
 - Observe the permissible inlet pressure.











	<p>Position "0":</p> <ul style="list-style-type: none"> • Switch setting for media without condensation • The gas ballast valve is closed • No gas flow into the suction chamber
	<p>Position "1":</p> <ul style="list-style-type: none"> • Switch setting for slight to medium condensation • The gas ballast valve is opened • The gas flow depends on the type
	<p>Position "2":</p> <ul style="list-style-type: none"> • Switch setting for medium to severe condensation • The gas ballast valve is opened • The gas flow depends on the type

Tbl. 17: HiScroll gas ballast valve switch settings





8.9 Operating mode display via LED

LEDs on the electronic drive unit show the basic operating states of the vacuum pump. A differentiated error and warning display is only possible for operation with the Pfeiffer Vacuum display and control unit or a PC.

LED	Symbol	LED status	Display	Meaning
Green 		Off	—	without current Standby off
		On, flashing		"Pumping station OFF", rotation speed ≤ 60 rpm
		On, flashing		"Pumping station OFF", rotation speed > 60 rpm
		On, inverse flashing		"Pumping station ON", set rotation speed not reached
		On, constant		"Pumping station ON", set rotation speed reached Standby on
		On, inverse flashes twice		Automatic speed canceled Auto-standby on

LED	Symbol	LED status	Display	Meaning
Yellow 		Off		no warning
		On, flashes quickly		Note ⁴⁾
		On, constant		Warning
		On, flickering 1 sec		Confirmation, command acceptance
Red 		Off		No error
		On, constant		Error

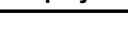
Tbl. 18: Behavior and meaning of the LEDs of the electronic drive unit

LED	Symbol	LED status	Display	Meaning
Green 		Off		Normal operation Standby operation inactive
		On, constant		Standby ON Operation with set standby speed
		On, flickering		Boost mode active

Tbl. 19: Behavior and meaning of the LED standby

8.10 Switching off the vacuum pump

The "Pumping station" parameter [P:010] comprises operation of the vacuum pump with control of all connected interfaces and configurations.

Procedure

1. Switch the running vacuum pump off by pressing the  button once.
2. Switch the voltage supply off.

Alternative: Switching off via the Pfeiffer Vacuum parameter

- ▶ Set the parameter [P:010] to the value "0".

Alternative: Switching off via "remote" interface

- ▶ Remove the bridge between pins 7 and 5.

4) Regularly check the performance data of the vacuum pump.

9 Maintenance

9.1 Maintenance information

WARNING

Danger to life from electric shock during maintenance and service work

There is a danger to life from electric shock when making contact with live components that still exist after the vacuum pump has been switched off.

- ▶ Disconnect the vacuum pump safely from the mains.
- ▶ Wait until the vacuum pump comes to a standstill (rotation speed = 0).
- ▶ After switching off the vacuum pump, wait another 5 minutes until the capacitors have discharged.

WARNING

Health hazard through poisoning from toxic contaminated components or devices

Toxic process media result in contamination of devices or parts of them. During maintenance work, there is a risk to health from contact with these poisonous substances. Illegal disposal of toxic substances causes environmental damage.

- ▶ Take suitable safety precautions and prevent health hazards or environmental pollution by toxic process media.
- ▶ Decontaminate affected parts before carrying out maintenance work.
- ▶ Wear protective equipment.

WARNING

Crushing and cutting danger on unprotected parts from unforeseeable automatic run-up during maintenance.

During activities on exposed mechanical components, there is a risk of crushing or cut injuries from sudden run-up.

- ▶ Switch off the vacuum pump before any maintenance work and work.
- ▶ Vent the vacuum pump to atmospheric pressure.
- ▶ Disconnect the vacuum pump safely from the mains.
- ▶ Secure the vacuum pump against re-start.
- ▶ Disconnect the mains cable from the vacuum pump.

NOTICE

Danger of property damage from improper maintenance

Unprofessional work on the vacuum pump will lead to damage for which Pfeiffer Vacuum accepts no liability.

- ▶ We recommend taking advantage of our service training offering.
- ▶ When ordering spare parts, specify the information on the nameplate.

General cleaning and maintenance work

- Clean the ventilation grille
- Clean the outside of the vacuum pump

9.2 Checklist for inspection and maintenance



Notes on maintenance intervals

Depending on the process, the required maintenance intervals may be shorter than the reference values specified in the table.

- Consult with Pfeiffer Vacuum Service about shorter maintenance intervals for extreme loads or for specific processes.



Yellow LED flashing: Checking performance data

The flashing yellow LED indicates that maintenance may be required. The wear and service life of the tip seals basically depend on the application. The HiScroll remains fully functional, even if there is a high level of wear to the tip seals. If the pumping capacity is no longer adequate, we recommend carrying out maintenance level 1.

- Regularly observe the performance data of the scroll pump.
- To reset the message, press and for 5 s at the same time

After replacing the tip seals, they need to be run in for a certain period of time. Operate the scroll pump for a while without a load in order to restore the performance data.



Maintenance level

We recommend that Pfeiffer Vacuum Service (PV) carry out maintenance work at level 3. Pfeiffer Vacuum will be released from all warranty and liability claims if maintenance work is not carried out properly. This also applies wherever parts other than original spare parts are used.

You can carry out maintenance work at **Level 1** yourself.

Action	Inspection	Maintenance level 1	Maintenance level 3	Required material
described in	OI	OI	SI	
Interval	daily	as required	5 years or 40,000 operating hours	
Inspection <ul style="list-style-type: none"> • Visual and acoustic test • Vacuum pump performance test • Equipment check for abrasion, discoloration and other anomalies • Creation of an action plan 	■			
Maintenance level 1 <ul style="list-style-type: none"> • Replacement of tip seal 		■		Tip seal maintenance set
Maintenance level 3 <ul style="list-style-type: none"> • Replacement of all wear parts • Complete cleaning 			■ (PV)	Maintenance set level 3

Tbl. 20: Maintenance intervals

9.3 Calibrating the pressure sensor

Pfeiffer Vacuum calibrated the pressure sensor at the factory.

Required aids

- Vacuum gauge for reference measurement on the vacuum system
- Pfeiffer Vacuum display and control unit or PC

Perform HV calibration

1. Operate vacuum system at final pressure.
2. Wait for stabilization period of at least 10 minutes.
3. Read off actual pressure value of reference measurement.
4. Use **[P:740]** to set actual pressure value to reference value.

Perform ATM calibration

1. Vent vacuum system to atmospheric pressure.
2. Wait for stabilization period of at least 10 minutes.
3. Use **[P:740]** to precisely set actual pressure value to daily pressure.

9.4 Changing the tip seal

Prerequisites

- Vacuum pump switched off
- Vacuum system vented to atmospheric pressure
- Electrical supply disconnected
- Mains cable disconnected
- Vacuum inlet sealed with the original protective cover

9.4.1 Disassembling the spiral housing

Required tool

- Allen key, WAF 5

Required consumables

- Laboratory gloves

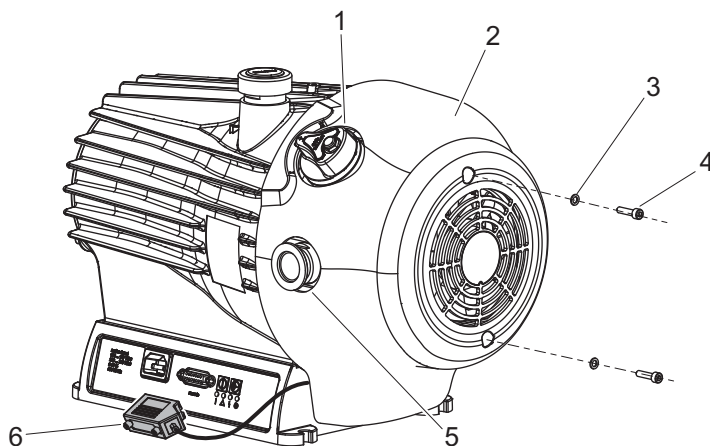

Fig. 16: Loosening the fan cover on the scroll pump

- | | |
|---------------------|---|
| 1 Gas ballast valve | 4 Interior hexagon socket screw |
| 2 Fan cover | 5 Exhaust connection without protective cap |
| 3 Washer | 6 Remote plug (optional) |

Loosening the fan cover

1. Undo an existing mating plug (e.g. for accessories) on the “remote” connection of the electronic drive unit.
2. Unscrew the 2 interior hexagon socket screws with washers from the fan cover.
3. Remove the protective cover from the exhaust connection if necessary.

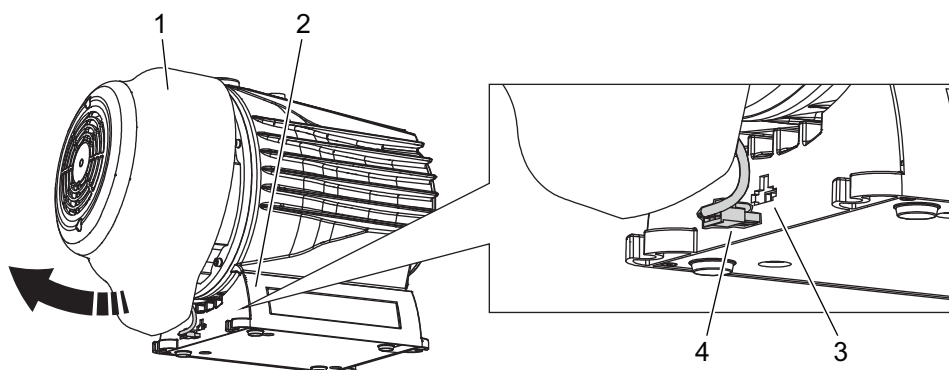

Fig. 17: Removing the fan cover on the scroll pump

- | | |
|-------------------------|-------------------------------------|
| 1 Fan cover | 3 Connecting socket for air cooling |
| 2 Electronic drive unit | 4 Fan cable |

Removing the fan cover

1. Pull the fan cover at the bottom slightly to the front.
2. Undo the plug of the fan cable on the electronic drive unit.
 - Be careful with the circlip.
3. Lift the fan cover over the gas ballast valve and the exhaust connection.
4. If necessary, close the exhaust connection with the original protective cover.

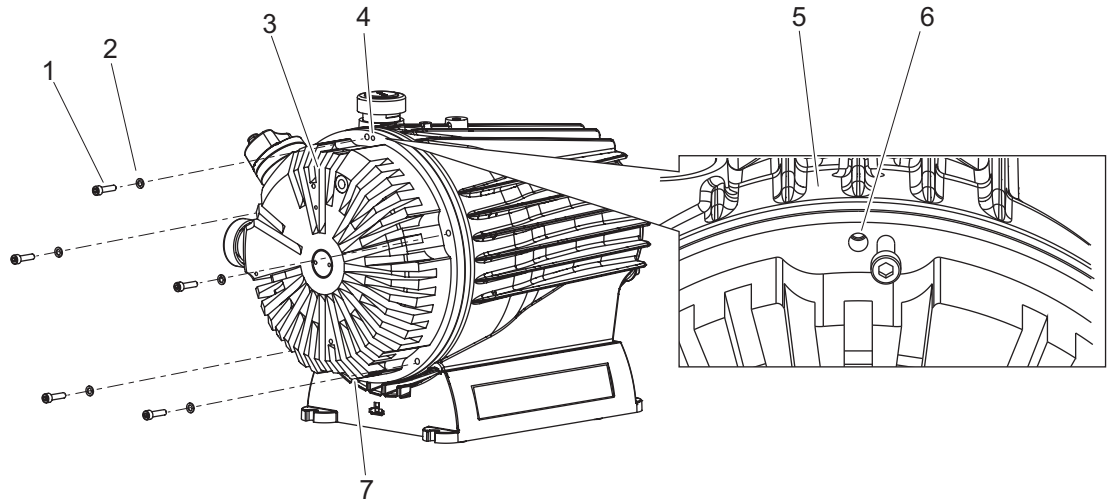

Fig. 18: Removing the scroll pump spiral housing

- | | |
|--------------------------------------|--|
| 1 Interior hexagon socket screw (5×) | 5 Pump housing |
| 2 Washer (5×) | 6 Interior hexagon socket screw as an auxiliary hole |
| 3 Spiral housing | 7 Bottom auxiliary hole |
| 4 Top auxiliary hole | |

Removing the spiral housing

1. Unscrew all 5 interior hexagon socket screws from the spiral housing.
 - Pay attention to the washers.
2. Screw the 2 interior hexagon socket screws evenly and alternately into the top and bottom auxiliary holes.
3. Push the spiral housing off the pump housing, ensuring that it does not tilt.
4. Unscrew the auxiliary screws from the spiral housing.

9.4.2 Replacing the tip seal

Required tools

- O-ring picker
- Side cutter

Required consumables

- Laboratory gloves
- Clean, lint-free cloth
- Isopropanol
- Spare part package 1

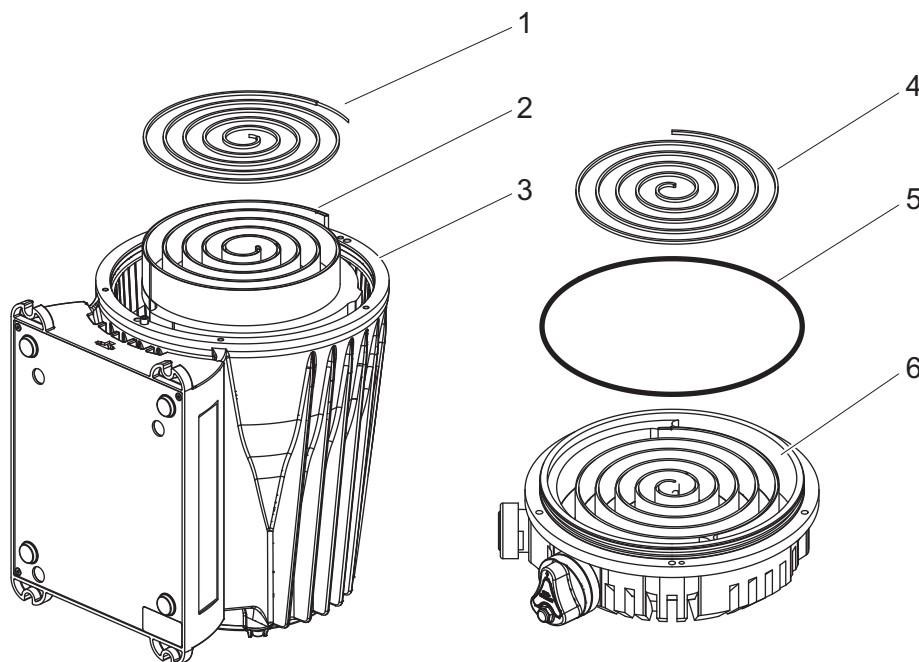

Fig. 19: Replacing the tip seal on the scroll pump

- | | |
|----------------|------------------|
| 1 Tip seal | 4 Tip seal |
| 2 Orbiter | 5 O-ring |
| 3 Pump housing | 6 Spiral housing |

Removing the tip seal

1. Place the pump housing in an upright position.
2. Use the o-ring picker and remove the o-ring from the spiral housing.
3. Use the o-ring picker and remove the tip seal from the orbiter.
4. Use the o-ring picker and remove the tip seal from the spiral housing.
5. Clean the working area of the orbiter and spiral housing as well as the spiral groove on both sides using a clean, lint-free cloth and a little isopropanol.
6. Clean the cooling fin on the spiral housing to remove any soiling that might impact the cooling performance.

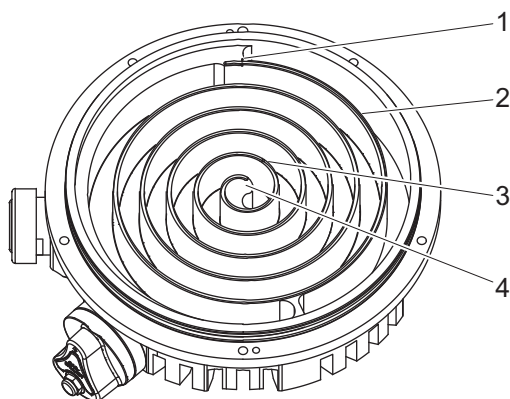

Fig. 20: Tip seal nut in the spiral housing

- | | |
|-----------------|-------------------|
| 1 Cut mark | 3 Clamping point |
| 2 Spiral groove | 4 Start of spiral |

Inserting the tip seal

The described steps apply equally to the spiral housing and the orbiter in the pump housing.

1. Press a new tip seal, starting from the inside, into the spiral groove.
 - The clamping points in the groove help you to fix the tip seal in place.
2. Carefully cut the tip seal at the outer cut mark using a side cutter.

3. Moisten the groove of the spiral housing with a little isopropanol as an assembly aid for the o-ring.
4. Carefully insert the o-ring into the spiral housing.

9.4.3 Assembling the pump housing

Required tool

- Allen key, **WAF 5**
- Calibrated torque wrench

Required consumables

- Laboratory gloves
- Isopropanol

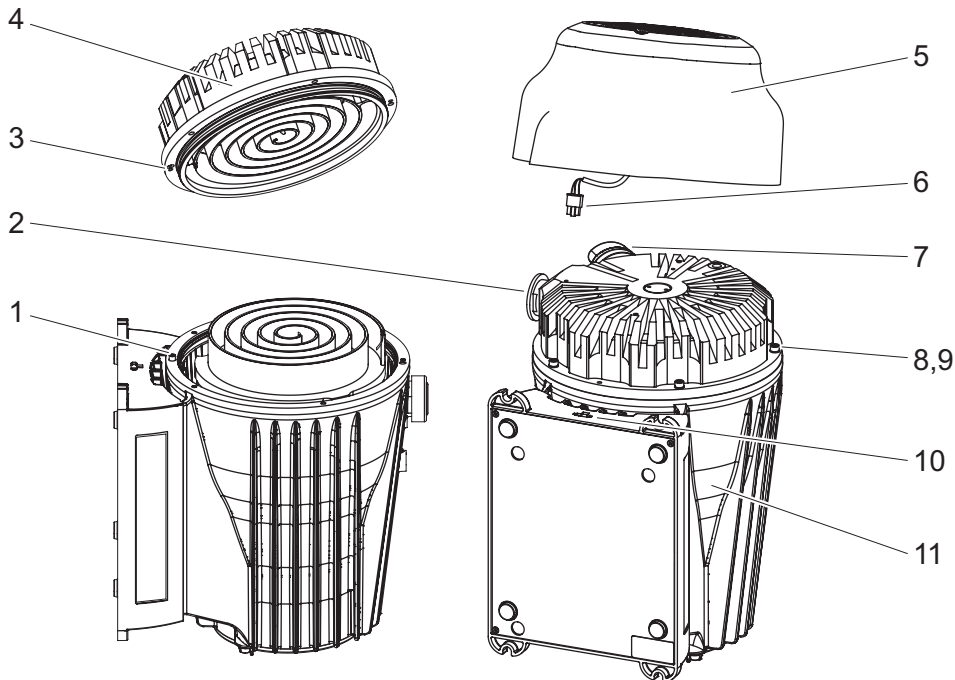

Fig. 21: Assembling the housing parts

- | | |
|---|--------------------------------------|
| 1 Guide pin | 7 Gas ballast valve |
| 2 Exhaust connection without protective cap | 8 Interior hexagon socket screw |
| 3 Guide hole | 9 Washer |
| 4 Spiral housing | 10 Connecting socket for air cooling |
| 5 Fan cover | 11 Pump housing |
| 6 Fan cable | |

Assembling the spiral housing

1. Remove the protective cover from the exhaust connection if necessary.
2. Moisten the o-ring in the spiral housing with a little isopropanol as an assembly aid for the o-ring.
3. Fit the spiral housing with the guide hole exactly on the guide pin of the pump housing.
 - Make sure that the tip seals remain in the grooves.
4. Screw the spiral housing with interior hexagon socket screws (5×) and washers firmly onto the pump housing.
5. Tighten the screws evenly and crosswise in steps.
 - Tightening torque: **5 Nm**

Assembling the fan cover

1. Fix the fan cable in place in the groove provided on the fan cover.
2. Place the fan cover over the gas ballast valve and exhaust connection on the spiral housing, ensuring that it is not tilted.
 - Pay attention to the existing cabling and the distance pin within the fan cover.
3. Plug the fan cable into the connecting socket of the electronic drive unit.

4. Secure the fan housing with both interior hexagon socket screws and washers.
 - Tightening torque: **3.5 Nm**
5. **Optional:** Fasten an existing mating plug on the “remote” connection of the electronic drive unit.
 - Tightening torque: **0.4 Nm**

9.5 Final inspection

Prerequisite

- Maintenance work carried out on opening the housing

Carry out final inspection

- ▶ Perform a functional test.
- ▶ Check to make sure the fan is working.

Recommended final check

1. Carry out a leak test.

10 Decommissioning

10.1 Shutting down for longer periods

WARNING

Health hazard through poisoning from toxic contaminated components or devices

Toxic process media result in contamination of devices or parts of them. During maintenance work, there is a risk to health from contact with these poisonous substances. Illegal disposal of toxic substances causes environmental damage.

- ▶ Take suitable safety precautions and prevent health hazards or environmental pollution by toxic process media.
- ▶ Decontaminate affected parts before carrying out maintenance work.
- ▶ Wear protective equipment.

Procedure for longer vacuum pump shutdowns

1. Switch off the vacuum pump.
2. Vent the vacuum pump.
3. Allow the vacuum pump to cool down.
4. Close the vacuum connection.
5. Evacuate the vacuum pump via the exhaust connection.
6. Evacuate the pump interior to $p < 1$ hPa.
7. Vent the vacuum pump with dry, oil-free air or inert gas.
8. Seal all connections with the original protective caps.
9. Store the vacuum pump in dry, dust-free rooms, within the specified ambient conditions.
10. In rooms with humid or aggressive atmospheres: Hermetically seal the vacuum pump together with a drying agent in a plastic bag.
11. Do not store the vacuum pump in the vicinity of machines, traffic routes, etc., as strong vibrations may damage the bearing.

10.2 Recommissioning

Checking the state

- ▶ Check the vacuum pump for visible damage.
- ▶ Check the vacuum pump for contamination and moisture.
- ▶ Put the vacuum pump into operation only if it is in a correct state.
- ▶ If necessary, consult Pfeiffer Vacuum Service

Procedure for recommissioning the vacuum pump

1. Clean the vacuum pump exterior with a lint-free cloth and a little isopropanol.
2. If necessary, arrange for Pfeiffer Vacuum Service to completely clean the vacuum pump.
3. Observe the total running time of the vacuum pump and if necessary, use support services of Pfeiffer Vacuum.
4. Install the vacuum pump according to these instructions ([see chapter "Installation", page 24](#)).
5. Recommission the vacuum pump according to these instructions ([see chapter "Operation", page 39](#)).

11 Recycling and disposal

⚠ WARNING

Health hazard through poisoning from toxic contaminated components or devices

Toxic process media result in contamination of devices or parts of them. During maintenance work, there is a risk to health from contact with these poisonous substances. Illegal disposal of toxic substances causes environmental damage.

- ▶ Take suitable safety precautions and prevent health hazards or environmental pollution by toxic process media.
- ▶ Decontaminate affected parts before carrying out maintenance work.
- ▶ Wear protective equipment.



Environmental protection

You **must** dispose of the product and its components in accordance with all applicable regulations for protecting people, the environment and nature.

- Help to reduce the wastage of natural resources.
- Prevent contamination.



Environmental protection

The product and its components **must be disposed of in accordance with the applicable regulations relating to environmental protection and human health**, with a view to reducing natural resource wastage and preventing pollution.

11.1 General disposal information

Pfeiffer Vacuum products contain materials that you must recycle.

- ▶ Dispose of our products according to the following:
 - Iron
 - Aluminium
 - Copper
 - Synthetic
 - Electronic components
 - Oil and fat, solvent-free
- ▶ Observe the special precautionary measures when disposing of:
 - Fluoroelastomers (FKM)
 - Potentially contaminated components that come into contact with media

11.2 Disposing of the scroll pump

Pfeiffer Vacuum scroll pumps contain materials which must be recycled.

1. Disconnect the electronic drive unit.
2. Dismantle the motor.
3. Decontaminate the components that come into contact with process gases.
4. Separate the components into recyclable materials.
5. Recycle the non-contaminated components.
6. Dispose of the product or components in a safe manner according to locally applicable regulations.

12 Malfunctions

12.1 General

WARNING

Danger to life from electric shock in the event of a fault

In the event of a fault, devices connected to the mains may be live. There is a danger to life from electric shock when making contact with live components.

- ▶ Always keep the mains connection freely accessible so you can disconnect it at any time.

Vacuum pump and electronic drive unit malfunctions always result in a warning or error message. In both cases, you will receive an error code that you can read out via the interfaces of the electronic drive unit. Generally, the LED on the electronic drive unit displays the operating messages. If an error occurs, the vacuum pump and connected devices will be switched off.

Problem	Possible causes	Remedy
The vacuum pump will not start up; none of the built-in LEDs on the electronic drive unit light up	<ul style="list-style-type: none"> • Current supply interrupted 	<ul style="list-style-type: none"> • Check the current supply lines.
	<ul style="list-style-type: none"> • Incorrect operating voltage 	<ul style="list-style-type: none"> • Supply the correct operating voltage.
	<ul style="list-style-type: none"> • Electronic drive unit defective 	<ul style="list-style-type: none"> • Contact Pfeiffer Vacuum Service.
The vacuum pump fails to reach the nominal rotation speed within the run-up time	<ul style="list-style-type: none"> • Leakage on the vacuum pump 	<ol style="list-style-type: none"> 1. Carry out leak detection. 2. Check seals and flange connections. 3. Eliminate leaks.
	<ul style="list-style-type: none"> • Gas throughput too high 	<ul style="list-style-type: none"> • Reduce the process gas load.
	<ul style="list-style-type: none"> • Rotor not running smoothly, defective bearing 	<ol style="list-style-type: none"> 1. Check the vacuum pump for noise development 2. Contact Pfeiffer Vacuum Service.
	<p>Thermal load due to:</p> <ul style="list-style-type: none"> • lack of ventilation • ambient temperature too high 	<ol style="list-style-type: none"> 1. Check to make sure the fan is working. <ul style="list-style-type: none"> – Check the fan connecting cable for a correct fit and damage. 2. Reduce the thermal load. <ul style="list-style-type: none"> – Ensure adequate air supply. – Adapt the ambient conditions.
Vacuum pump does not reach ultimate pressure	<ul style="list-style-type: none"> • The vacuum pump is contaminated 	<ol style="list-style-type: none"> 1. Contact Pfeiffer Vacuum Service. 2. Have it cleaned.
	<ul style="list-style-type: none"> • Vacuum chamber, pipes or vacuum pump are leaking 	<ol style="list-style-type: none"> 1. Carry out leak detection starting from the vacuum chamber. 2. Check seals and flange connections. 3. Eliminate leaks in the vacuum system.
	<ul style="list-style-type: none"> • Pressure measurement incorrect or not calibrated 	<ul style="list-style-type: none"> • Check the pressure measurement settings. • Calibrate the integrated pressure sensor. <ul style="list-style-type: none"> – Use a vacuum gauge for the reference measurement.
	<ul style="list-style-type: none"> • Condensate in the suction chamber 	<ol style="list-style-type: none"> 1. Check the process medium. 2. Operate the scroll pump with gas ballast.
	<ul style="list-style-type: none"> • Seal the tip seal 	<ul style="list-style-type: none"> • Contact Pfeiffer Vacuum Service. • Replace the tip seal.
	<ul style="list-style-type: none"> • Tip seal insufficiently run in (e.g., after tip seal replacement) 	<ul style="list-style-type: none"> • Operate the vacuum pump with no load for a while

Unusual noises during operation	<ul style="list-style-type: none"> • Bearing is damaged 	<ul style="list-style-type: none"> • Contact Pfeiffer Vacuum Service.
	<ul style="list-style-type: none"> • Rotor damaged 	<ul style="list-style-type: none"> • Contact Pfeiffer Vacuum Service.
	<ul style="list-style-type: none"> • Spiral element contaminated or damaged 	<ul style="list-style-type: none"> • Contact Pfeiffer Vacuum Service.
Red LED on the electronic drive unit illuminates	<ul style="list-style-type: none"> • Group error 	<ol style="list-style-type: none"> 1. Reset the error by pressing the OFF/ON  button. 2. Set the parameter [P: 010] via the interface RS-485 to 0 = off and then 1 = On and Malfunction acknowledgment. 3. Reset the malfunction with V+ on pin 13 on the “remote” connection. 4. Set the parameter [P: 009] via the interface RS-485 to 1 = Malfunction acknowledgment. 5. Reset the malfunction by switching the current supply off and on. 6. Carry out a differentiated malfunction analysis with a display and control unit. 7. Contact Pfeiffer Vacuum Service.

Tbl. 21: Troubleshooting with scroll pumps

12.2 Error codes

Errors (** Error E—— **) always cause the connected peripheral devices to be switched off.

Warnings (* Warning F —— *) are only displayed and do not cause components to be switched off.



Handle malfunction messages

1. Read out error codes via Pfeiffer display and control units or a PC.
2. Remove the cause of the malfunction.
3. Reset the malfunction message with parameter **[P:009]**.
 - Use preconfigured quick keys with the symbol  or display tiles on Pfeiffer Vacuum display and control units.

Error code	Problem	Possible causes	Remedy
Err001	Excess rotation speed	–	<ul style="list-style-type: none"> • Contact Pfeiffer Vacuum Service • Only acknowledge for rotational speed f = 0
Err002	Excess voltage	<ul style="list-style-type: none"> • Incorrect mains input voltage 	<ul style="list-style-type: none"> • Check the mains input voltage • Only acknowledge for rotational speed f = 0 • Contact Pfeiffer Vacuum Service
Err006	Overload	<ul style="list-style-type: none"> • Load too high • Rotation speed cannot be maintained 	<ul style="list-style-type: none"> • Reduce the load (poss. limited power due to excess temperature)
Err021	Pump not recognized		<ul style="list-style-type: none"> • Contact Pfeiffer Vacuum Service
Err037	Overflow motor end stage		<ul style="list-style-type: none"> • Contact Pfeiffer Vacuum Service
Err041	Overflow motor end stage		<ul style="list-style-type: none"> • Contact Pfeiffer Vacuum Service
Err044	Excess temperature, electronics	<ul style="list-style-type: none"> • Insufficient cooling 	<ul style="list-style-type: none"> • Check to make sure the fan is working. • Check the fan connecting cable for a correct fit and damage. • Improve the cooling • Check the operating conditions
Err045	Excess temperature, motor	<ul style="list-style-type: none"> • Insufficient cooling 	<ul style="list-style-type: none"> • Check to make sure the fan is working. • Check the fan connecting cable for a correct fit and damage. • Improve the cooling • Check the operating conditions
Err093	Motor temperature evaluation faulty	–	<ul style="list-style-type: none"> • Contact Pfeiffer Vacuum Service
Err094	Electronics temperature evaluation faulty		<ul style="list-style-type: none"> • Contact Pfeiffer Vacuum Service

Error code	Problem	Possible causes	Remedy
Err098	Internal communication error	–	<ul style="list-style-type: none"> • Contact Pfeiffer Vacuum Service
Err114	Final stage temperature evaluation faulty	–	<ul style="list-style-type: none"> • Contact Pfeiffer Vacuum Service
Err118	Excess temperature, final stage	<ul style="list-style-type: none"> • Insufficient cooling 	<ul style="list-style-type: none"> • Check to make sure the fan is working. • Check the fan connecting cable for a correct fit and damage. • Improve the cooling • Check the operating conditions
Err175	PFC excess current		<ul style="list-style-type: none"> • Contact Pfeiffer Vacuum Service
Err176	Flash Program Error		<ul style="list-style-type: none"> • Contact Pfeiffer Vacuum Service
Err825	Internal communication error		<ul style="list-style-type: none"> • Contact Pfeiffer Vacuum Service
Err913	Direction of rotation	Incorrect direction of rotation	<ul style="list-style-type: none"> • Contact Pfeiffer Vacuum Service

Tbl. 22: Error messages of the electronic drive unit

Error code	Problem	Possible causes	Remedy
Wrn007	Undervoltage or power failure	<ul style="list-style-type: none"> • Mains failure 	<ul style="list-style-type: none"> • Check the mains input voltage
Wrn037	Auto standby inactive	<ul style="list-style-type: none"> • Control set to remote 	<ul style="list-style-type: none"> • Deactivate the remote priority
Wrn038	Pressure regulation error	<ul style="list-style-type: none"> • Target pressure cannot be reached 	<ul style="list-style-type: none"> • Increase or decrease the gas load
Wrn040	Note	Maintenance level 1 recommended	<ul style="list-style-type: none"> • Regularly check the performance data of the vacuum pump • If necessary, perform maintenance • To reset the message, press  and  for 5 s at the same time
Wrn042	Maintenance required	Have maintenance performed	<ul style="list-style-type: none"> • Contact Pfeiffer Vacuum Service
Wrn044	Electronics high temperature	<ul style="list-style-type: none"> • Insufficient cooling 	<ul style="list-style-type: none"> • Check to make sure the fan is working. • Check the fan connecting cable for a correct fit and damage. • Improve the cooling • Check the operating conditions
Wrn045	Motor high temperature	<ul style="list-style-type: none"> • Insufficient cooling 	<ul style="list-style-type: none"> • Check to make sure the fan is working. • Check the fan connecting cable for a correct fit and damage. • Improve the cooling • Check the operating conditions
Wrn118	High power electronics temperature	<ul style="list-style-type: none"> • Insufficient cooling 	<ul style="list-style-type: none"> • Check to make sure the fan is working. • Check the fan connecting cable for a correct fit and damage. • Improve the cooling • Check the operating conditions

Tbl. 23: Warning messages of the electronic drive unit

12.3 Warning and error messages when operating with DCU

Besides the device-specific warning and error messages on the electronic drive unit, additional messages are displayed with the connected display and control panel.

Display in DCU	Problem	Possible causes	Remedy
* Warning F110 *	Pressure gauge	<ul style="list-style-type: none"> Pressure gauge faulty Connection to the pressure gauge disconnected during operation 	<ul style="list-style-type: none"> Check the cable connection Carry out a restart with pressure gauge connected Replace the pressure gauge completely
** Error E040 **	Hardware error	<ul style="list-style-type: none"> external RAM faulty 	<ul style="list-style-type: none"> Contact Pfeiffer Vacuum Service.
** Error E042 **	Hardware error	<ul style="list-style-type: none"> EPROM checksum incorrect 	<ul style="list-style-type: none"> Contact Pfeiffer Vacuum Service.
** Error E043 **	Hardware error	<ul style="list-style-type: none"> E²PROM write error 	<ul style="list-style-type: none"> Contact Pfeiffer Vacuum Service.
** Error E090 **	Internal device error	<ul style="list-style-type: none"> RAM not large enough DCU is connected to incorrect electronic drive unit 	<ul style="list-style-type: none"> Contact Pfeiffer Vacuum Service. Connect the DCU to the correct electronic drive unit
** Error E698 **	Communication error	<ul style="list-style-type: none"> Electronic drive unit is not responding 	<ul style="list-style-type: none"> Contact Pfeiffer Vacuum Service.

Tbl. 24: Warning and error messages when using a DCU

13 Service solutions by Pfeiffer Vacuum

We offer first-class service

High vacuum component service life, in combination with low downtime, are clear expectations that you place on us. We meet your needs with efficient products and outstanding service.

We are always focused on perfecting our core competence – servicing of vacuum components. Once you have purchased a product from Pfeiffer Vacuum, our service is far from over. This is often exactly where service begins. Obviously, in proven Pfeiffer Vacuum quality.

Our professional sales and service employees are available to provide you with reliable assistance, worldwide. Pfeiffer Vacuum offers an entire range of services, from original replacement parts to service contracts.

Make use of Pfeiffer Vacuum service

Whether preventive, on-site service carried out by our field service, fast replacement with mint condition replacement products, or repair carried out in a Service Center near you – you have various options for maintaining your equipment availability. You can find more detailed information and addresses on our homepage, in the Pfeiffer Vacuum Service section.

You can obtain advice on the optimal solution for you, from your Pfeiffer Vacuum representative.

For fast and smooth service process handling, we recommend the following:

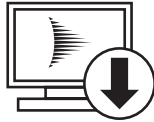

1. Download the up-to-date form templates.
 - Explanations of service requests
 - Service requests
 - Contamination declaration



- a) Remove and store all accessories (all external parts, such as valves, protective screens, etc.).
 - b) If necessary, drain operating fluid/lubricant.
 - c) If necessary, drain coolant.
2. Complete the service request and contamination declaration.



3. Send the forms by email, fax, or post to your local Service Center.



4. You will receive an acknowledgment from Pfeiffer Vacuum.

PFEIFFER VACUUM

Submission of contaminated products

No microbiological, explosive, or radiologically contaminated products will be accepted. Where products are contaminated, or the contamination declaration is missing, Pfeiffer Vacuum will contact you before starting service work. Depending on the product and degree of pollution, **additional decontamination costs** may be incurred.

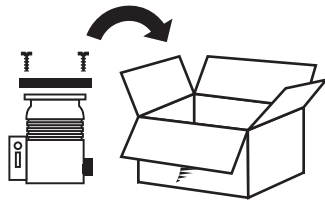

5. Prepare the product for transport in accordance with the provisions in the contamination declaration.
 - a) Neutralize the product with nitrogen or dry air.
 - b) Seal all openings with blind flanges, so that they are airtight.
 - c) Shrink-wrap the product in suitable protective foil.
 - d) Package the product in suitable, stable transport containers only.
 - e) Maintain applicable transport conditions.

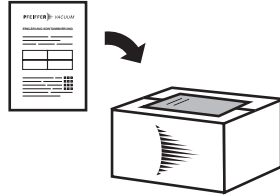

6. Attach the contamination declaration to the **outside** of the packaging.

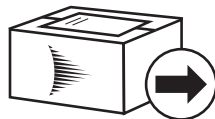

7. Now send your product to your local Service Center.

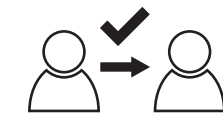

8. You will receive an acknowledgment/quotation, from Pfeiffer Vacuum.

PFEIFFER VACUUM

Our sales and delivery conditions and repair and maintenance conditions for vacuum devices and components apply to all service orders.

14 Accessories

14.1 Accessory information

Display units

Display and operating units are used to check and adjust operating parameters.

Cable and adapter

Mains, interface, connection, and extension cables provide a secure and suitable connection. Different lengths on request

Integrated pressure measurement

Evaluation and control by the integrated electronic drive unit, independently of an additional power supply

Condensate separator

Protect the vacuum pump against fluids from the intake line and from the condensate return from the exhaust line

Dust separators

Protect the vacuum pump from particles out of the process

14.2 Order accessories

Article	Order number
Mains cable 230 V AC, CEE 7/7 to C13, 3 m	P 4564 309 ZA
Mains cable 115 V AC, NEMA 5-15 to C13, 3 m	P 4564 309 ZL
DCU 002, Display Control Unit	PM 061 348 AT
HPU 001, Handheld Programming Unit	PM 051 510 -T
SAS 25 S, DN 25 ISO-KF, polyester filter	PK Z60 507
Push-in fitting G 1/8" including seal for hose connection (8/6 mm)	P 4131 029
Screw cap for gas ballast valve	PD 100 067 -T
RPT 010, digital Piezo/Pirani sensor	PD 100 100 -T
Connection cable HiScroll - HiPace - TC110 - TPS, 3m	PM 071 733 -T
Connection cable HiScroll - HiPace - TC400, 3m	PM 071 732 -T
Adapter RS485 M12	PE 100 150 -X
Interface cable, M12 m straight/M12 m straight, 3 m	PM 061 283 -T
Y-connector M12 for RS-485	P 4723 010
USB RS-485 converter	PM 061 207 -T

Tbl. 25: Accessories for HiScroll

15 Technical data and dimensions

15.1 General

Basis for the technical data of Pfeiffer Vacuum spiral vacuum pumps:

- Specifications according to PNEUROP committee PN5
- ISO 21360-1 2016: "Vacuum technology - Standard methods for measuring vacuum-pump performance - Part 1: General description"
- Integral leakage rate with 100 % helium concentration, 10 s measurement duration

	mbar	bar	Pa	hPa	kPa	Torr mm Hg
mbar	1	$1 \cdot 10^{-3}$	100	1	0.1	0.75
bar	1000	1	$1 \cdot 10^5$	1000	100	750
Pa	0.01	$1 \cdot 10^{-5}$	1	0.01	$1 \cdot 10^{-3}$	$7.5 \cdot 10^{-3}$
hPa	1	$1 \cdot 10^{-3}$	100	1	0.1	0.75
kPa	10	0.01	1000	10	1	7.5
Torr mm Hg	1.33	$1.33 \cdot 10^{-3}$	133.32	1.33	0.133	1

1 Pa = 1 N/m²

Tbl. 26: Conversion table: Pressure units

	mbar l/s	Pa m ³ /s	sccm	Torr l/s	atm cm ³ /s
mbar l/s	1	0.1	59.2	0.75	0.987
Pa m ³ /s	10	1	592	7.5	9.87
sccm	$1.69 \cdot 10^{-2}$	$1.69 \cdot 10^{-3}$	1	$1.27 \cdot 10^{-2}$	$1.67 \cdot 10^{-2}$
Torr l/s	1.33	0.133	78.9	1	1.32
atm cm ³ /s	1.01	0.101	59.8	0.76	1

Tbl. 27: Conversion table: Units for gas throughput

15.2 Technical data



Performance data

The vacuum pump usually reaches its typical ultimate pressure after a certain running time.

Selection field	HiScroll 12, Scroll Pump, Standard	HiScroll 12, Scroll Pump, Standard, incl. pressure sensor
Connection flange (in)	DN 25 ISO-KF	DN 25 ISO-KF
Connection flange (out)	DN 25 ISO-KF	DN 25 ISO-KF
Part number	PD S20 000	PD S20 010
Cooling method	Air, Forced convection	Air, Forced convection
Typical ultimate pressure	$9 \cdot 10^{-3}$ hPa	$9 \cdot 10^{-3}$ hPa
Typical ultimate pressure at gas ballast stage 1	$5 \cdot 10^{-2}$ hPa	$5 \cdot 10^{-2}$ hPa
Typical ultimate pressure at gas ballast stage 2	$4 \cdot 10^{-1}$ hPa	$4 \cdot 10^{-1}$ hPa
Intake pressure max.	1100 hPa	1100 hPa
Recommended continuous inlet pressure, max.	200 hPa	200 hPa
Exhaust pressure, max.	1500 hPa	1500 hPa
Pumping speed	12.1 m ³ /h	12.1 m ³ /h
Gas ballast	Yes	Yes

Selection field	HiScroll 12, Scroll Pump, Standard	HiScroll 12, Scroll Pump, Standard, incl. pressure sensor
Gas ballast pressure	≤ 1500 hPa	≤ 1500 hPa
Gas ballast flow stage 1	18 l/min	18 l/min
Gas ballast flow stage 2	30 l/min	30 l/min
Rotation speed	624 – 1 870 rpm	624 – 1 870 rpm
Nominal rotation speed	1560 rpm	1560 rpm
Mains connection	100 — 127/200 — 240 V AC (±10 %), 50/60 Hz	100 — 127/200 — 240 V AC (±10 %), 50/60 Hz
Rated current consumption	100 V – 127 V: 8 A 200 V – 240 V: 4 A	100 V – 127 V: 8 A 200 V – 240 V: 4 A
Motor protection	Internal	Internal
Mains cable included	No	No
I/O interfaces	RS-485	RS-485
Emission sound pressure level (EN ISO 2151)	47 dB(A)	47 dB(A)
Operating altitude, max.	2500 m	2500 m
Protection degree	IP20	IP20
Ambient temperature	5 – 40 °C	5 – 40 °C
Temperature: Storage	-10 – 50 °C	-10 – 50 °C
Temperature: Shipping	-25 – 55 °C	-25 – 55 °C
Leakage rate	$5 \cdot 10^{-7}$ Pa m ³ /s	$5 \cdot 10^{-7}$ Pa m ³ /s
Weight	24 kg	24 kg

Tbl. 28: Technical data for HiScroll 12

Selection field	HiScroll 18, Scroll Pump, Standard	HiScroll 18, Scroll Pump, Standard, incl. pressure sensor
Connection flange (in)	DN 25 ISO-KF	DN 25 ISO-KF
Connection flange (out)	DN 25 ISO-KF	DN 25 ISO-KF
Part number	PD S30 000	PD S30 010
Cooling method	Air, Forced convection	Air, Forced convection
Typical ultimate pressure	$7 \cdot 10^{-3}$ hPa	$7 \cdot 10^{-3}$ hPa
Typical ultimate pressure at gas ballast stage 1	$3 \cdot 10^{-2}$ hPa	$3 \cdot 10^{-2}$ hPa
Typical ultimate pressure at gas ballast stage 2	$2 \cdot 10^{-1}$ hPa	$2 \cdot 10^{-1}$ hPa
Intake pressure max.	1100 hPa	1100 hPa
Recommended continuous inlet pressure, max.	200 hPa	200 hPa
Exhaust pressure, max.	1500 hPa	1500 hPa
Pumping speed	18.1 m ³ /h	18.1 m ³ /h
Gas ballast	Yes	Yes
Gas ballast pressure	≤ 1500 hPa	≤ 1500 hPa
Gas ballast flow stage 1	23 l/min	23 l/min
Gas ballast flow stage 2	30 l/min	30 l/min
Rotation speed	624 – 1 870 rpm	624 – 1 870 rpm
Nominal rotation speed	1560 rpm	1560 rpm
Mains connection	100 — 127/200 — 240 V AC (±10 %), 50/60 Hz	100 — 127/200 — 240 V AC (±10 %), 50/60 Hz
Rated current consumption	100 V – 127 V: 10 A 200 V – 240 V: 6 A	100 V – 127 V: 10 A 200 V – 240 V: 6 A
Motor protection	Internal	Internal

Selection field	HiScroll 18, Scroll Pump, Standard	HiScroll 18, Scroll Pump, Standard, incl. pressure sensor
Mains cable included	No	No
I/O interfaces	RS-485	RS-485
Emission sound pressure level (EN ISO 2151)	47 dB(A)	47 dB(A)
Operating altitude, max.	2500 m	2500 m
Protection degree	IP20	IP20
Ambient temperature	5 – 40 °C	5 – 40 °C
Temperature: Storage	-10 – 50 °C	-10 – 50 °C
Temperature: Shipping	-25 – 55 °C	-25 – 55 °C
Leakage rate	$5 \cdot 10^{-7}$ Pa m ³ /s	$5 \cdot 10^{-7}$ Pa m ³ /s
Weight	23 kg	23 kg

Tbl. 29: Technical data for HiScroll 18

15.3 Substances in contact with the media

Pump parts	Substances in contact with the media	Standard	With pressure sensor
Housing	Aluminium	X	X
Inlet flange	Stainless steel	X	X
Outlet flange	Stainless steel	X	X
Corrugated bellows	Stainless steel	X	X
Pumping system	Anodized aluminum, PTFE compound	X	X
Non-return valve	Stainless steel, FKM	X	X
Gas ballast valve	Nickel-plated aluminum, stainless steel, FKM, PTFE	X	X
Screw-in filter gas ballast valve	Bronze/brass	X	X
Pressure sensor RPT	Ceramic, nickel, stainless steel, tungsten, silicon dioxide, araldite, solder	-	X
Screws	Stainless steel	X	X
Seals	FKM	X	X

Tbl. 30: Materials that make contact with the process media

15.4 Dimensions

Dimensions in mm

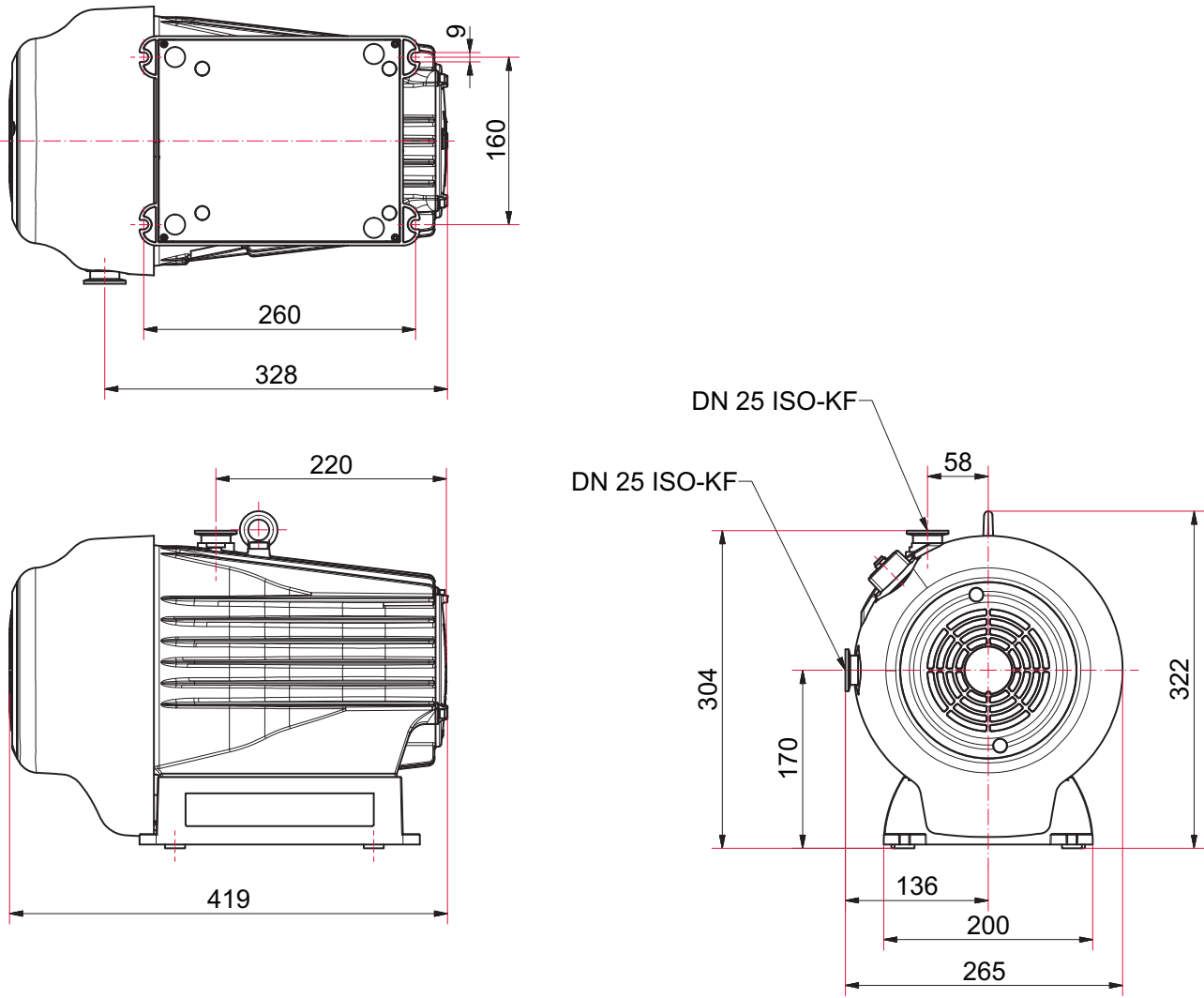

Fig. 22: HiScroll 12 | HiScroll 18

Declaration of conformity

Declaration for product(s) of the type:

Scroll Pumps

HiScroll 12

HiScroll 18

We hereby declare that the listed product satisfies all relevant provisions of the following **European Directives**.

- **Machinery 2006/42/EC (Annex II, no. 1 A)**
- **Electromagnetic compatibility 2014/30/EU**
- **Restriction of the use of certain hazardous substances 2011/65/EU**
- **Restriction of the use of certain hazardous substances, delegated directive 2015/863/EU**

Harmonized standards and applied national standards and specifications

EN ISO 12100: 2011

EN 61000-3-2: 2015

EN 1012-2: 2011-12

EN 61000-3-3: 2014

EN ISO 13857: 2008

EN 61326-1: 2012

ISO 21360-1: 2016

DIN EN 50581: 2013

ISO 21360-2: 2012

The authorized representative for the compilation of technical documents is Mr. Wolfgang Bremer, Pfeiffer Vacuum GmbH, Berliner Straße 43, 35614 Asslar, Germany.

Signature:



(Daniel Sälzer)
Managing Director

Pfeiffer Vacuum GmbH
Berliner Straße 43
35614 Asslar
Germany

Asslar, 2020-03-31

VACUUM SOLUTIONS FROM A SINGLE SOURCE

Pfeiffer Vacuum stands for innovative and custom vacuum solutions worldwide, technological perfection, competent advice and reliable service.

COMPLETE RANGE OF PRODUCTS

From a single component to complex systems:

We are the only supplier of vacuum technology that provides a complete product portfolio.

COMPETENCE IN THEORY AND PRACTICE

Benefit from our know-how and our portfolio of training opportunities!

We support you with your plant layout and provide first-class on-site service worldwide.

ed. D - Date 2011 - P/N:PU0081BEN



Are you looking for a
perfect vacuum solution?
Please contact us

Pfeiffer Vacuum GmbH
Headquarters • Germany
T +49 6441 802-0
info@pfeiffer-vacuum.de

www.pfeiffer-vacuum.com

PFEIFFER  **VACUUM**