

Scroll Pumps

XDS35i, XDS35iC, XDS35iE and XDS35iCE

INSTRUCTION MANUAL

edwardsvacuum.com



DESCRIPTION	ELECTRICAL SUPPLY	ITEM NUMBER
XDS35i Scroll Pump (set to high volts)	100-120 V, 200-230 V, 50/60 Hz - Set to 200 - 230 V	A730YY983
XDS35i Scroll Pump (set to low volts)	100-120 V, 200-230 V, 50/60 Hz - Set to 100 - 120 V	A730YY986
XDS35i Scroll Pump	100-120 V, 200-230 V, 50/60 Hz - Set to 200 - 230 V	A7300983
XDS35iC Scroll Pump Chemical	100-120 V, 200-230 V, 50/60 Hz - Set to 200 - 230 V	A73006938
XDS35i Scroll Pump (No Gas Ballast)	100-120 V, 200-230 V, 50/60 Hz - Set to 200 - 230 V	A73005983
XDS35iE Scroll Pump Enhanced	100-120 V, 200-230 V, 50/60 Hz - Set to 200 - 230 V	A73003983
XDS35iCE Scroll Pump Enhanced Chemical	100-120 V, 200-230 V, 50/60 Hz - Set to 200 - 230 V	A730983
XDS35iE Scroll Pump Enhanced (No Gas Ballast)	100-120 V, 200-230 V, 50/60 Hz - Set to 200 - 230 V	A73007983

Copyright notice

©Edwards Limited 2020. All rights reserved.

Trademark credit

Edwards and the Edwards logo are trademarks of Edwards Limited, Innovation Drive, Burgess Hill, West Sussex RH15 9TW.

Associated publications

Publication title	Publication number
Vacuum Pump and Vacuum System Safety	P40040100
Tip Seal Replacement Kit Manual	A73001840
By-pass Valves Exchange Manual	A73001860

Disclaimer

The content of this manual may change from time to time without notice. We accept no liability for any errors that may appear in this manual nor do we make any expressed or implied warranties regarding the content. As far as practical we have ensured that the products have been designed and constructed to be safe and without risks when properly installed and used in accordance with their operating instructions.

We accept no liability for loss of profit, loss of market or any other indirect or consequential loss whatsoever.

Product warranty and limit of liability are dealt with in our standard terms and conditions of sale or negotiated contract under which this document is supplied.

You must use this product as described in this manual. Read the manual before you install, operate, or maintain the product.

CE Declaration of Conformity

Edwards Ltd
Innovation Drive
Burgess Hill
West Sussex
RH15 9TW
UK

The following product

XDS35i scroll pump, set to High volts	100-120 V, 200-230 V, 1 ph, 50/60 Hz	A730-YY-983
XDS35i scroll pump, set to Low volts	100-120 V, 200-230 V, 1 ph, 50/60 Hz	A730-YY-986
XDS35i scroll pump, no gas ballast	100-120 V, 200-230 V, 1 ph, 50/60 Hz	A730-05-983
XDS35iC scroll pump	100-120 V, 200-230 V, 1 ph, 50/60 Hz	A730-06-983
XDS35iE scroll pump, enhanced	100-120 V, 200-230 V, 1 ph, 50/60 Hz	A730-03-983
XDS35iE scroll pump, enhanced, no gas ballast	100-120 V, 200-230 V, 1 ph, 50/60 Hz	A730-07-983
XDS35iCE scroll pump, enhanced	100-120 V, 200-230 V, 1 ph, 50/60 Hz	A730-08-983
XDS46i scroll pump	100-120 V, 200-230 V, 1 ph, 50/60 Hz	A731-01-983
XDS46iC scroll pump	100-120 V, 200-230 V, 1 ph, 50/60 Hz	A731-06-983
II Internal 3 G Ex h IIB T4 Gc		YY = 00 to 99
XDS100B scroll pump <i>Note: no ATEX rating</i>	100-120 V, 200-230 V, 1 ph, 50/60Hz	A732-01-983

Is in conformity with the relevant requirements of European CE legislation:

2006/42/EC	Machinery directive
2014/34/EU	ATEX directive on use in potentially explosive atmospheres
2014/30/EU	Electromagnetic compatibility (EMC) directive
2011/65/EU	Restriction of certain hazardous substances (RoHS) directive as amended by Delegated Directive (EU) 2015/863

Based on the relevant requirements of harmonised standards:

EN 1012-2:1996 +A1:2009	Compressors and vacuum pumps. Safety requirements. Vacuum pumps
EN ISO 80079-36:2016	Explosive atmospheres – Part 36: Non-electrical equipment for explosive atmospheres. Basic method and requirements
EN ISO 80079-37:2016	Explosive atmospheres - Part 37: Non-electrical equipment for explosive atmospheres -- Non-electrical type of protection constructional safety "c", control of ignition sources "b", liquid immersion "k"
EN 61326-1:2013	Electrical equipment for measurement, control and laboratory use. EMC requirements. General requirements Class A Emissions, Industrial Immunity

Documentation Officer: Jelena Havelkova, Spielberg Office Centre, Holandska 10, Brno, 63900 Czech Republic,
☎: +42(0) 734 418 896, ✉: documentation@edwardsvacuum.com

This declaration, based on the requirements of the listed Directives and EN ISO/IEC 17050-1, covers all product serial numbers from this date on: 29th October 2019

Petr Smerek – Engineering Manager
Scientific Vacuum Division
Lutin

Ian Keech – General Manager
Product Company
Lutin

Additional Legislation and Compliance Information

EU EMC Directive: Class A/B Industrial equipment

Caution: This equipment is not intended for use in residential environments and may not provide adequate protection to radio reception in such environments.

EU RoHS Directive: Material Exemption Information

This product is compliant with the following Annex III Exemptions:

- 6(b) **Lead** as an alloying element in aluminium containing up to 0.4% by weight
- 6(c) Copper alloy containing up to 4% **lead** by weight

EU REACH Regulation Compliance

This product is a complex article which is not designed for intentional substance release. To the best of our knowledge the materials used comply with the requirements of REACH. The product manual provides information and instruction to ensure the safe storage, use, maintenance and disposal of the product including any substance based requirements.

Article 33.1 Declaration

This product does contain Candidate List Substances of Very High Concern above 0.1%ww by article as clarified under the 2015 European Court of Justice ruling in case C-106/14.

- Lead (Pb) added to the Candidate List June 2018

As indicated by the applied RoHS exemption(s) above this substance is present in aluminium and brass components.

ADDITIONAL INFORMATION

The products listed are also in scope for and comply with the requirements of the following:

2012/19/EU	Directive on waste electrical and electronic equipment (WEEE)
Product is certified to CSA-C22.2 No.61010-1-12	Safety requirements for electrical equipment for measurement, control and laboratory use – Part 1: General requirements
Product conforms to UL61010-1 3 rd Edition	Safety requirements for electrical equipment for measurement, control and laboratory use – Part 1: General requirements

材料成分声明

China Material Content Declaration

部件名称 Part name	有害物质 Hazardous Substances					
	铅 Lead (Pb)	汞 Mercury (Hg)	镉 Cadmium (Cd)	六价铬 Hexavalent Chromium (Cr VI)	多溴联苯 Polybrominated biphenyls (PBB)	多溴二苯醚 Polybrominated diphenyl ethers (PBDE)
铸铝及铝合金制品 Aluminium alloys	X	O	O	O	O	O
铜管管件 Brass pipe fitting	X	O	O	O	O	O
铜接头 Brass connectors	X	O	O	O	O	O

O: 表示该有害物质在该部件的所有均质材料中的含量低于 GB/T 26572 标准规定的限量要求。

O: Indicates that the hazardous substance contained in all of the homogeneous materials for this part is below the limit requirement in GB/T 26572.

X: 表示该有害物质在该部件的至少一种均质材料中的含量超出 GB/T26572 标准规定的限量要求。

X: Indicates that the hazardous substance contained in at least one of the homogeneous materials used for this part is above the limit requirement of GB/T26572.

Contents

1. Safety and compliance.	6
1.1 Definition of Warnings and Cautions.	6
1.2 Safety symbols.	6
2. Introduction.	8
2.1 Scope of this manual.	8
2.2 ATEX directive implication.	8
2.3 Description.	9
2.4 Gas ballast control.	10
2.5 Construction.	11
3. Technical data.	12
3.1 Operating and storage conditions.	12
3.2 Performance.	12
3.2.1 Performance characteristics.	13
3.3 Mechanical data.	14
3.4 Electrical data.	14
3.4.1 Electrical cables.	15
4. Installation.	16
4.1 Safety.	16
4.2 System design considerations.	17
4.3 Unpack and inspect.	19
4.4 Locate the pump.	19
4.4.1 Mechanical fixing.	19
4.5 Electrical installation.	20
4.5.1 Check and configure the pump.	20
4.5.2 Connect the pump to the electrical supply.	20
4.6 Inlet and outlet connections.	20
4.7 Leak test the system.	21
5. Operation.	22
5.1 Use of gas ballast control (if fitted).	22
5.1.1 Gas ballast control.	22
5.2 Start up procedure.	22
5.3 To achieve ultimate vacuum (if gas ballast fitted).	23
5.4 To pump condensable vapours (if gas ballast fitted).	23
5.5 Implication of ATEX directive.	23
5.5.1 Flammable/pyrophoric materials.	23
5.5.2 Gas purges.	23

5.6 Remote operation using 15-way D connector.	24
5.7 Shut down.	25
6. Maintenance.	26
6.1 Safety information.	26
6.2 Maintenance plan.	27
6.3 Inspect and clean the inlet strainer.	27
6.4 Inspect and clean the gas ballast control (if fitted).	28
6.5 Clean the external fan cover.	29
6.6 Replace the tip seals.	29
6.7 Test the motor condition.	29
7. Fault finding.	31
7.1 The pump has failed to start or has stopped.	31
7.2 The pump has failed to achieve the required performance.	31
7.3 The pump is noisy.	31
7.4 The pump surface temperature is high.	32
7.5 The pumping speed is poor or if pump down time is too long.	32
8. Storage and disposal.	33
8.1 Storage.	33
8.2 Disposal.	33
9. Service and spares.	34
9.1 Introduction.	34
9.2 Accessories.	34
9.2.1 Electrical cables.	34
9.2.2 Silencer.	34
9.2.3 Gas ballast adaptor.	34
9.2.4 Solenoid operated pipeline valves.	34
9.3 Service.	35
9.3.1 Return the equipment or components for service.	35
9.4 Service kits.	36
9.4.1 Tip seal and exhaust service kit.	36
9.4.2 Bypass valve kit.	36
9.4.3 Gas ballast kit.	36

List of Figures

Figure 1: General view.	9
Figure 2: Performance characteristics of XDS35i.	13
Figure 3: Performance characteristics of XDS35iE.	14
Figure 4: Installation drawing (dimensions in mm).	18
Figure 5: Logic interface schematic.	25
Figure 6: Inlet strainer assembly.	28
Figure 7: Gas ballast control assembly.	29

1. Safety and compliance

1.1 Definition of Warnings and Cautions

NOTICE:



This manual meets our obligation to provide you with information. For safe operation from the start, read these instructions carefully before you install or commission the equipment.

Read all the safety instructions in this section and the rest of this manual carefully and make sure that you obey these instructions. The equipment must only be operated and maintained by trained personnel in the proper condition and as described in this instruction manual.

Obey local and state requirements and regulations. If you have any questions about safety, operation or maintenance of the device, please contact our nearest subsidiary.

Important safety information is highlighted as warning and caution instructions. Obey these instructions.



WARNING:

If you do not obey a warning, there is a risk of injury or death. Different symbols are used according to the type of hazard.



CAUTION:

If you do not obey a caution, there is a risk of minor injury, damage to equipment, related equipment or process.



NOTICE:

Information about properties or instructions for an action which, if ignored, will cause damage to the pump or the system.





We reserve the right to change the design and the stated data. The illustrations are not binding.

Keep the instructions for future use.

1.2 Safety symbols

The safety symbols on the products shows the areas where care and attention is necessary.

The safety symbols that follow are used on the product or in the product documentation.

	<p>Warning/Caution A safety instruction which must be followed.</p>
	<p>Warning - Heavy object Identifies a possible hazard from a heavy object.</p>
	<p>Warning - Dangerous voltage Identifies possible hazards from dangerous voltages.</p>
	<p>Warning - Hot surfaces Identifies a potential hazard from a hot surface.</p>
	<p>Warning - Use protective equipment Use appropriate protective equipment.</p>

2. Introduction

2.1 Scope of this manual

This manual provides installation, operation and maintenance instructions for the XDS35i, XDS35iC, XDS35iE, and XDS35iCE scroll pumps. The pump must be used as specified in this manual. Read this manual before installing and operating the pump.

2.2 ATEX directive implication

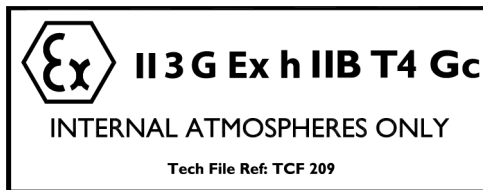

This equipment is designed to meet the requirements of Group II Category 3 equipment in accordance with Directive 2014/34/EU of the European Parliament and the Council of 29th March 2014 on the approximation of the laws of the Member States concerning equipment and protective systems intended for use in potentially explosive atmospheres. (The ATEX Directive)

The ATEX Category 3 applies in respect of potential ignition sources internal to the equipment. An ATEX Category has not been assigned in respect of potential ignition sources on the outside of the equipment as the equipment has not been designed for use where there is an external potentially explosive atmosphere.

There is no potential source of ignition within the pump during normal operation but there may be potential sources of ignition under conditions of foreseeable and rare malfunction as defined in the Directive. Accordingly, although the pump is designed to pump flammable materials and mixtures, operating procedures should ensure that under all normal and reasonably foreseeable conditions, these materials and mixtures are not within explosive limits. Category 3 is considered appropriate for the avoidance of ignition in the case of a rare malfunction which allows flammable materials or mixtures to pass through the pump whilst within their explosive limits.

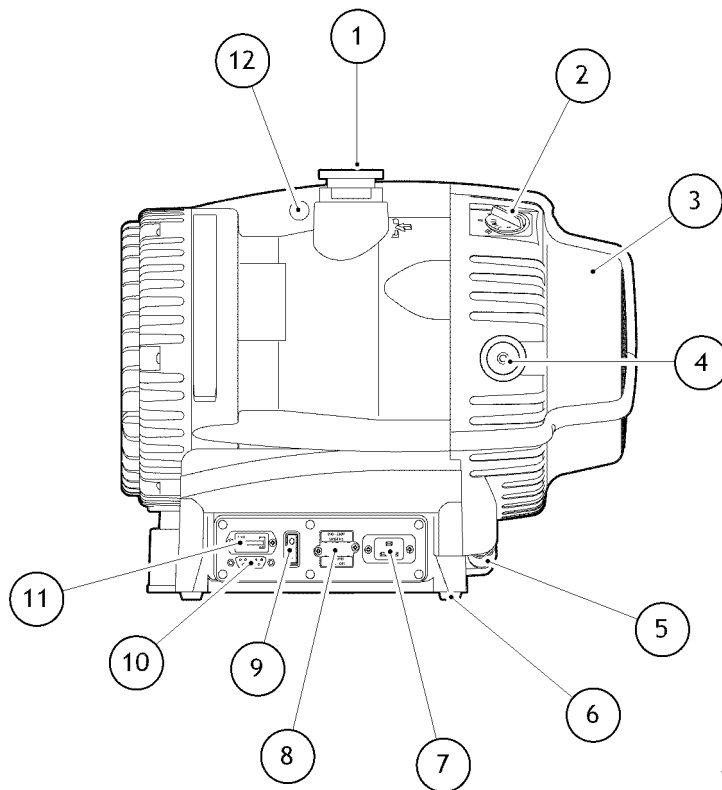
Figure 1 General view

- | | |
|-----------------------|---|
| 1. NW40 inlet port | 2. Gas ballast control (not fitted on No Gas Ballast variant) |
| 3. Cooling fan | 4. NW25 exhaust port |
| 5. Fan connector | 6. Rubber feet |
| 7. Electric connector | 8. Voltage changeover switch cover |
| 9. Run/Standby switch | 10. 15-way connector |
| 11. Hour counter | 12. Lifting eye |

2.3 Description

Refer to [Figure: General view on page 9](#) for item numbers in brackets in the following descriptions.

The XDS pump is a compact, reliable vacuum pump which is suitable for use on vapour handling processes. It may be used for some pumping applications involving corrosive substances and particulates, for information on pumping flammable gases, please refer to [Implication of ATEX directive on page 23](#) and contact us for any further assistance.

The body of the pump includes a fixed scroll and an orbiting scroll. The orbiting scroll is controlled by the electric motor through an eccentric cam on the motor drive shaft. The movement of the orbiting scroll, meshed with the fixed scroll, forms successive crescent shaped volumes in the pump. Gas that enters the pump through the inlet is compressed by the movement of the orbiting scroll and swept towards the centre of the fixed scroll. The compressed gas enters the exhaust port near the centre of the stationary scroll and is exhausted from the pump through the outlet.

The XDS is a dry vacuum pump, as all the bearings, with their hydrocarbon lubricant, are isolated from the vacuum space.

The pump has an NW40 (item 1) inlet and inlet strainer.

The pump mechanism is driven directly by a three-phase electric motor. The motor is controlled by a drive, which manages the supply of current to the motor in accordance with operating conditions and allows the pump to be connected to a single phase supply. The voltage changeover switch beneath the voltage changeover switch cover (item 8) must be set to the correct position in accordance with the power supply being used, refer to [Connect the pump to the electrical supply on page 20](#).

The pump is designed to run from atmospheric pressure however, if the inlet pressure exceeds 100 mbar for an extended period, the inverter may reduce the motor speed. The pump will speed up again after the pressure is reduced. Maximum rated continuous operating pressure at 40 °C ambient is 40 mbar.

The enhanced pump versions (XDS35iE and 35iCE) are equipped with patented technology which prevents over-compression within the scroll mechanism at high operational pressure and large throughput applications. Twin by-pass valves release sufficiently compressed gas directly to the pump exhaust, increasing pump efficiency, lowering power consumption and enhancing pumping speed. Valve operation occurs at inlet pressures greater than 300 mbar, meaning the pump is tailored towards applications which dwell at higher pressure. The elimination of over-compression at high operational pressure, reduces power consumption and diminishes bearing loads, extending bearing life. Consequently, the enhanced versions are capable of operation without limitations to both the size of vacuum chamber, or the frequency of pump down on cyclic duties.

 **Note:**

The pump modifications within the enhanced version have a small adverse effect on the ultimate vacuum achieved however, the pump has a larger tolerance to operating altitude and ambient temperature.

The pump is air-cooled by a fan (item 3) mounted at the opposite end to the motor. The fan will continue to run for one minute after the pump is switched off. The pump incorporates a thermal protection device that will stop the motor in the event of thermal overload, for example, high ambient temperature. The pump will restart after cooling down.

2.4 Gas ballast control

To pump high vapour loads, gas ballast can be delivered into the pump to prevent condensation of the vapour carried by the pumped gases.

Air can be introduced to the low vacuum stages through the gas ballast control (item 2) (not fitted on the No Gas Ballast variant). Alternatively, an inert gas such as nitrogen can be supplied through a suitable external valve and by using the appropriate adaptor, available as an accessory, refer to [Gas ballast adaptor on page 34](#).

The gas ballast control has three positions:

- Closed (position '0')
- Low flow (position 'I')
- High flow (position 'II')

2.5 Construction

The pump scrolls are made of anodised aluminium. The motor housing is aluminium. All surfaces of the pump which are exposed to the pumped gases are free from copper, zinc and cadmium.

Other materials of construction include fluorocarbon elastomer, nitrile, chemically resistant polymers, nickel, stainless steel and a PTFE composite material.

3. Technical data



WARNING:

If the pump is operated outside the specific limits, the pump housing may become hot.

3.1 Operating and storage conditions

Table 1 Operating and storage conditions

Ambient temperature range (operation)	+ 10 °C to + 40 °C
Maximum surface temperature of pump body under normal operating conditions and maximum ambient temperature	+ 40 °C to + 65 °C
Maximum humidity (operation)	90% RH
Ambient temperature range (storage)	- 30 °C to + 70 °C
Pollution	Pollution degree 2
Installation	Installation category II
Altitude restriction	UL/CSA approved maximum 2000 m (3000 m for E variant self certified)
Area of use	Indoor use

3.2 Performance

Table 2 General characteristics

Maximum pumping speed	35 m ³ /h
Maximum permitted continuous inlet pressure	40 mbar (1000 mbar for E variant)*
Maximum permitted continuous exhaust pressure	0.2 bar (g)
Maximum permitted gas ballast inlet pressure	0.5 bar (g)
Maximum chamber volume to pump down from atmospheric pressure	100 litres†
Maximum chamber volume for cyclic duty-maximum 6 cycles per hour	50 litres†
Maximum initial pressure rise with no gas ballast flow	5 mbar l
Suck-back protection	By exhaust valve
Leak tightness	< 1 x 10 ⁻⁶ mbar l s ⁻¹
Maximum displacement	44 m ³ /hr

Sound pressure, measured at ultimate vacuum 1 metre from the end of the pump to ISO 3744 and ISO 4871	57 dB (A)
Vibration: measured at the inlet port (ISO 3744)	Class 1C...< 4.5 mm s ⁻¹ (rms radial)

**Use at higher inlet pressure speeds up the tip seal wear.*

†Enhanced version is not limited for maximum chamber volume or number of cycles per hour.

3.2.1 Performance characteristics

The position of the gas ballast control defines the performance characteristics of the pump.

Note:

Does not apply to No Gas Ballast variants

Table 3 Performance characteristics

Gas ballast control position	XDS35i Ultimate total pressure (mbar)	XDS35iE Ultimate total pressure (mbar)	Gas ballast flow (l min ⁻¹)
0	< 0.01	< 0.03	-
1	< 0.02	< 0.04	3
2	< 10.0	< 10.0	12

Figure 2 Performance characteristics of XDS35i

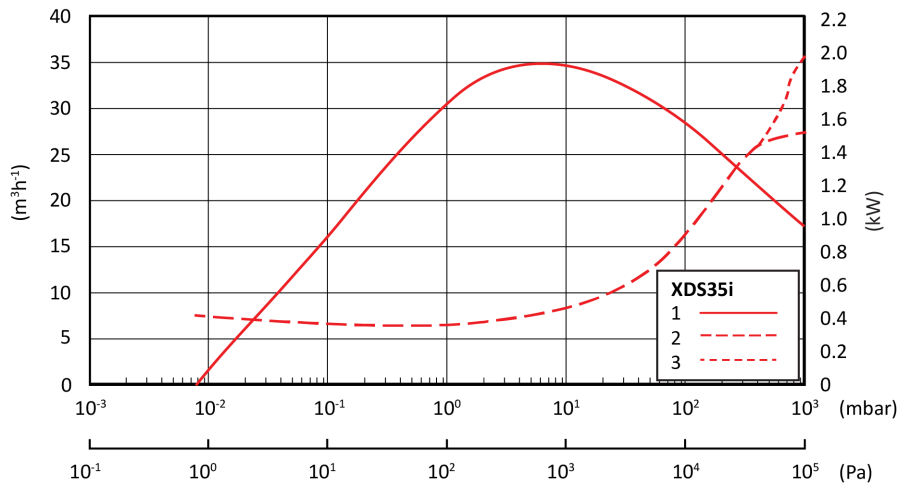

Note:

XDS35i can operate with high peak power for 90 seconds before activation of a thermal protection algorithm which reduces rotational and pumping speed.

Figure 3 Performance characteristics of XDS35iE

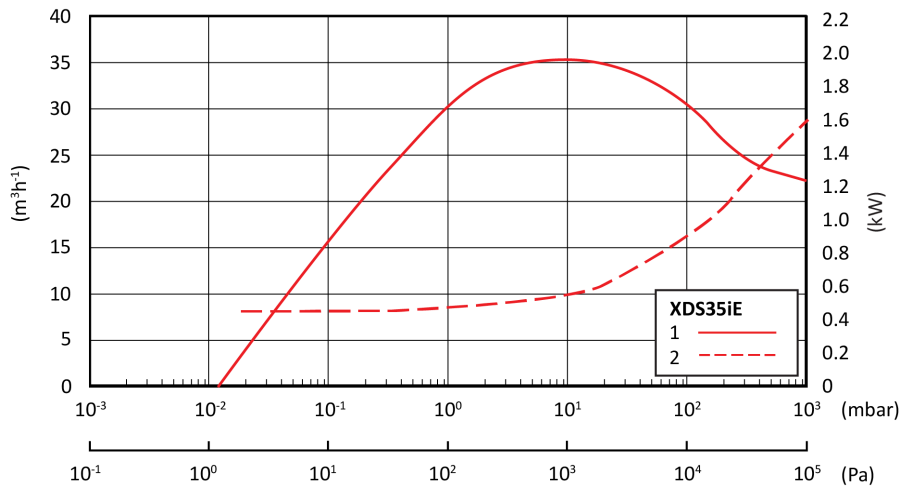

The power consumption of the enhanced version at high inlet pressure can be lowered by a further 100 W more with the installation of a second exhaust silencer by an NW25 T-piece.

Table 4 Typical pump down times of XDS35iE

Chamber size [m ³]	Pump down time [minutes]
1	14.5
3	43.3
10	144.3
30	432.7

The XDS35iE is suitable for regular, rapid pumping of small chambers or for evacuation of large volumes with no maximum chamber limit.

3.3 Mechanical data

Table 5 General mechanical data

Overall dimensions (L x W x H)	476 x 333 x 396 mm
Maximum tilt angle	10 degrees
Nominal rotational speed	1750 rpm
Mass	48 kg
Inlet connection	NW40
Outlet connection	NW25
Degree of protection (IEC60529)	IP44

3.4 Electrical data

Pumps are supplied set to 200 - 230 V.

Table 6 Electrical data

Supply (V)	Phase	Frequency (Hz)	Current (A)
200 - 230	Single	50 - 60	6.6
100 - 120	Single	50 - 60	10.6

Table 7 Recommended regional supply protection

Area	Voltage	Rating
UK	230 V	13 A
Europe	230 V	16 A
US	120 V	15 A
Japan	100 V	15 A

3.4.1 Electrical cables

Recommended cordsets and fuses for regional requirements.

Table 8 Recommended cordsets

Description	Rating	Coupler type	Item number
Cord set assembly, UK	Cable Style = H05VV-F, 3 x 1.5 mm ² , 300 V, 70 °C, maximum length of 2.5 metres Plug Type = BS1363 UK plug	Straight entry	A50505003
	Appliance coupler = IEC60320 style C19 Fuse Type = BS1362 13 amp fuse, to an IEC60320 style	Right angled entry	A50505006
Cord set assembly, Europe	Cable Style = H05VV-F, 3 x 1.5 mm ² , 300 V, 70 °C, maximum length of 2.5 metres Plug Type = European Schuko VDE approved, 16 A 250 V rated with dual earthing contact	Straight entry	A50506003
	Appliance coupler = IEC60320 style C19	Right angled entry	A50506006
Cord set assembly, USA/Canada (200 - 230 V)	Cable style = SJT, 3 x 14 AWG, 300 V, 90 °C, VW-1 maximum length of 3 metres Plug Type = NEMA, 6-15P plug Appliance coupler = IEC 60320 style C19		N/A

4. Installation

4.1 Safety

**WARNING:**

Obey the safety instructions in this section and take note of appropriate precautions. Failure to observe these instructions may result in injury to people and damage to equipment.

**WARNING:**

Do not expose any part of the human body to vacuum as it can cause injury.

**WARNING:**

The pump is not recommended for pumping explosive gases or hazardous substances.

**WARNING:**

Use suitable lifting equipment to move the pump. The mass is approximately 48 kg.

**WARNING:**

Take care when moving the pump into position. The pump's weight makes it difficult to slide and movement should only be attempted by two people.

- A suitably trained and supervised technician must install the pump.
- Ensure that the installation technician is familiar with the safety procedures that relate to the products processed by the pump.
- Wear the appropriate safety clothing when coming into contact with contaminated components.
- Dismantle and clean contaminated components inside a fume cupboard.
- Vent and purge the vacuum system before starting installation work.
- Disconnect other components in the pump from the electrical supply so that they cannot be operated accidentally.
- Refer to the Vacuum Pump and Vacuum System Safety manual (publication number P40040100) before installing and using the pump to process hazardous or flammable materials.
- Safely route any electrical cables and pipes to prevent a trip hazard.
- Check all required components are available and are of the correct type before starting work.
- Do not reuse O-rings or seals.

- Leak test the system after installation is complete and seal any leaks found to prevent leakage of hazardous substances out of the system and leakage of air into the system.
- Mechanical lifting equipment should be attached to the lifting eye on the pump.
- Loose slings should not be used to lift the pump.

4.2 System design considerations



WARNING:

Ensure the exhaust pipeline cannot become blocked. If an exhaust isolation valve is fitted, ensure the pump cannot be operated with the valve closed.

Consider the following points when designing the pumping system:

We recommend the use of a foreline vacuum isolation valve to allow the pump to warm up before pumping condensable vapours or if the vacuum needs to be maintained when the pump is not running.

Avoid high levels of heat input into the pump from the process gases, otherwise the pump may overheat and cause the thermal overload device to open.

If the pump is used in a high ambient temperature with high gas throughput, the pump body temperature may approach 65 °C. We recommend the use of additional guarding to prevent contact with hot surfaces under these conditions.

Dilute flammable mixtures to safe concentrations by providing an inert gas dilution purge. Contact our applications team for further advice on dilution requirements if required.

Figure 4 Installation drawing (dimensions in mm)

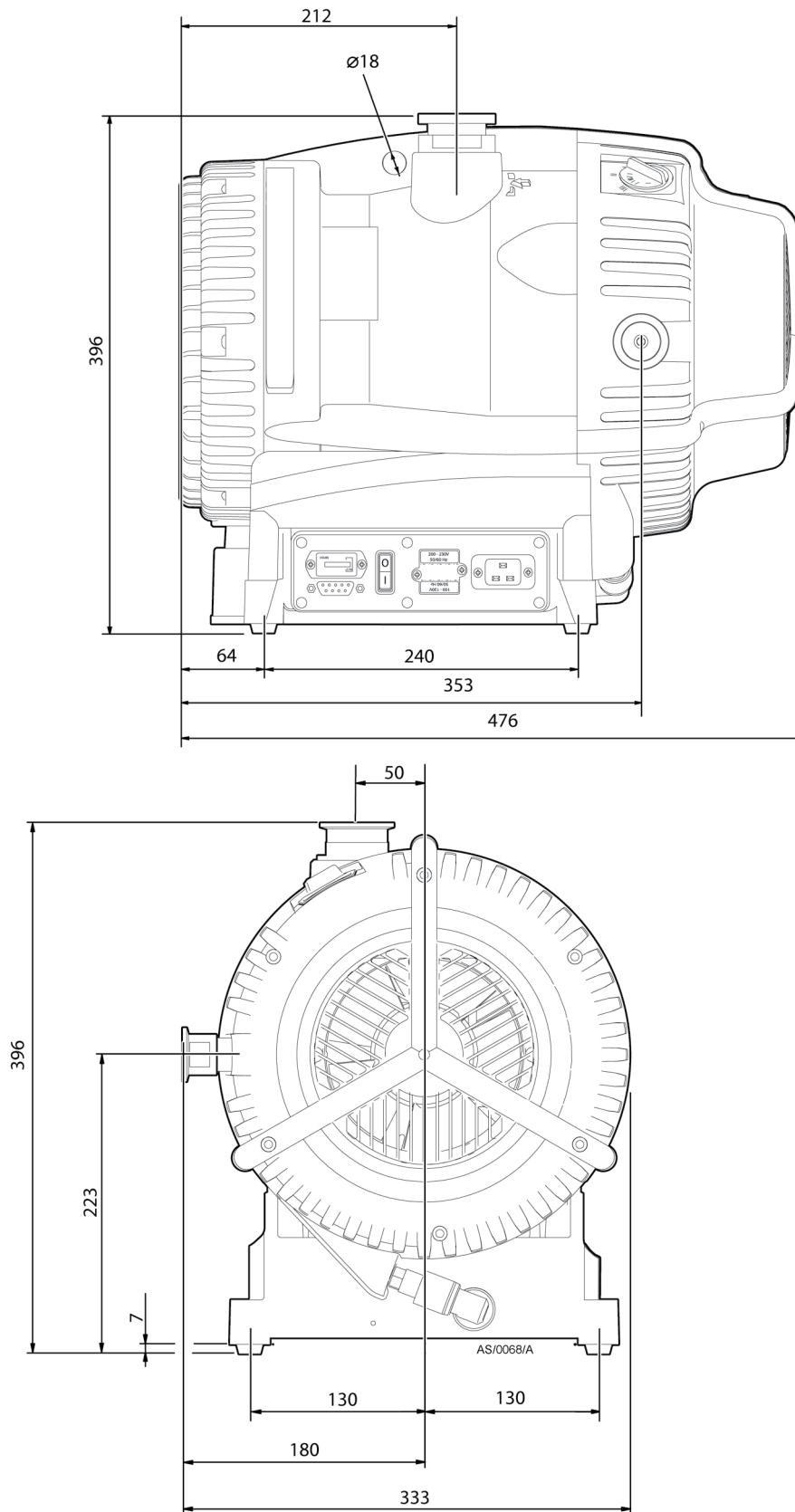

4.3 Unpack and inspect



WARNING:

Use suitable lifting equipment to move the pump. Mechanical equipment should be attached to the lifting eyes, loose slings should not be used. Failure to do so can cause injury to people and damage to the equipment. Refer to [Table: General mechanical data on page 14](#) for the mass of the pump.

Remove all packing materials, remove the pump from its packing box, remove the protective covers from the inlet and outlet ports and inspect the pump.

If the pump is damaged, notify the supplier and carrier in writing within three days, state the Item Number of the pump together with the order number and supplier's invoice number. Retain all packing materials for inspection. Do not use the pump if it is damaged.

If the pump is not to be used immediately, replace the protective covers. Store the pump in suitable conditions, as described in [Storage on page 33](#). Refer to [Disposal on page 33](#) for disposal of materials.

4.4 Locate the pump



WARNING:

Route and secure cables, hoses and pipework during installation to avoid possible risk of trips.



CAUTION:

If the pump will be located inside an enclosure, ensure there is adequate ventilation at both ends of the pump, so that the ambient temperature of the pump does not exceed 40 °C. A minimum space of 25 mm between the pump and the enclosure walls is required.

Provide a firm, level platform for the pump. Locate the pump so that the gas ballast control (if fitted) and the Run/Standby switch is accessible.

4.4.1 Mechanical fixing



CAUTION:

Use the four holes located on each corner of the pump base to secure the pump, if required. We recommend you to use of M8 bolts.

4.5 Electrical installation

4.5.1 Check and configure the pump

**CAUTION:**

Isolate the power supply before changing the voltage. Failure to configure the pump electrical supply correctly can result in damage to the pump.

Ensure that the voltage shown on the voltage indicator (refer to [Figure: General view on page 9](#)) on the motor cover corresponds with the electrical supply voltage. If not, change the configuration of the pump motor to match the supply voltage using the following procedure.

1. Undo the two screws and lift off the voltage indicator moulding.
2. Rotate the voltage indicator moulding so that the correct voltage is uppermost.
3. Replace the two screws.

4.5.2 Connect the pump to the electrical supply

**WARNING:**

Ensure that the XDS pump electrical installation conforms to local and national safety requirements. It must be connected to a suitably fused and protected electrical supply with a suitable earth (ground) point.

**WARNING:**

If using an earth leakage device, for example, an RCD, use a 30 mA rated unit at minimum to avoid tripping during start up.

**WARNING:**

The pump will automatically restart after restoration of the power supply following power failure.

For recommended regional supply protection and cordsets, refer to [Electrical data on page 14](#).

4.6 Inlet and outlet connections

**WARNING:**

If pumping dangerous gases or vapours, connect the exhaust to a suitable treatment plant to prevent the discharge of dangerous gases and vapours to the surrounding atmosphere.

**WARNING:**

If pumping for a prolonged period above 100 mbar inlet pressure, use an exhaust silencer (refer to [Silencer on page 34](#)) or connect to an appropriate exhaust line.

Before connecting the pump to the vacuum system, remove the plastic cap from the inlet and exhaust and ensure the inlet strainer is fitted to the pump inlet port. Use appropriate NW40 vacuum fittings for connection to the system.

Take note of the following information when connecting the pump to the vacuum system.

- To minimise noise and exhaust emissions, it is recommended that the pump is connected to an exhaust line or a silencer (refer to [Silencer on page 34](#)).
- For optimum pumping speeds, ensure that the pipeline connected to the pump inlet is as short as possible and has a suitable internal diameter.
- Support the vacuum pipeline to prevent loading of the coupling joints.
- If the pump is operated with the exhaust line blocked, a pressure of 5.5 bar(a) may be generated in the exhaust pipework. Connect the pump using appropriate pipework and fittings.
- If necessary, incorporate flexible bellows in the system pipelines to reduce the transmission of vibration and prevent loading of the coupling joints. If using flexible bellows, ensure the use of bellows that have a maximum pressure rating which is greater than the highest pressure that can be generated in the system. The use of manufacturer's bellows is recommended.
- Incorporate an inlet isolation valve in the pipeline between the vacuum system and pump. This will isolate the vacuum system from the pump when it is switched off and prevent the suck-back of process gases and debris into the vacuum system.
- Ensure that the sealing surfaces are clean and scratch-free.

We recommend the use of an exhaust extraction system suitable for use with all process gases being pumped. Ensure that the exhaust extraction system cannot become blocked or obstructed when the pump is operating.

A small amount of tip seal wear dust may collect in the exhaust duct of the pump. The dust may be blown out with the initial burst of air after the pump has been vented. This is quite common and the amount of dust seen will reduce over time.

4.7 Leak test the system

Leak test the system and seal any leaks found after installing the pump.

5. Operation

5.1 Use of gas ballast control (if fitted)

The gas ballast control can be used to optimise the performance of the scroll pump for the application. The performance characteristics of the pump with the different ballast settings are shown in [Table: Performance characteristics on page 13](#). The position of the gas ballast control can be changed when the pump is off or operating.

5.1.1 Gas ballast control

Use the gas ballast control to change the amount of air introduced into the final stage of the pump. Use of gas ballast will reduce the condensation of vapours in the pump, the condensates would contaminate the pump. The gas ballast control can be set to select one of three options:

To select no gas ballast, turn the control position to '0'. Use this setting:

- to achieve ultimate vacuum
- to pump dry gases.

To select low flow gas ballast, turn the control to position 'I'. Use this setting:

- to pump low concentrations of condensable vapours
- to decontaminate the pump.

To select high flow gas ballast, turn the control to position 'II'. Use this setting:

- to pump high concentrations of condensable vapours
- to clear excess vapours after processing.

High flow gas ballast 'II' is not intended for long term use as tip seal wear is accelerated. For continuous operation, to dilute condensable vapours for example, gas ballast position 'I' is recommended.

5.2 Start up procedure



WARNING:

Ensure that the system design does not allow the exhaust pipeline to become blocked.



CAUTION:

A fine dust may be emitted from the exhaust of the scroll pump during start up, particularly when the pump is new or if new tip seals are fitted.

Use the procedure below to start up the pump:

1. Ensure that any vacuum system isolation valve is closed (if fitted).
2. Connect a suitable lead from the power supply to the appliance inlet at the side of the pump.

3. Switch on the electrical supply to the pump, using the Run/Standby switch *Figure: General view on page 9*, item 9.
4. With manual operation always use the Run/Standby switch to start/stop the pump. If remote operation is used to control the pump, refer to *Remote operation using 15-way D connector on page 24*.
5. Open the vacuum system isolation valve (if fitted).

5.3 To achieve ultimate vacuum (if gas ballast fitted)

In order to achieve the best possible vacuum, the pump should be operated with the gas ballast control on position '0'. However, if the pump, or elements of the vacuum system it is attached to, are new or have been newly fitted, some atmospheric moisture may be present. If atmospheric moisture is present, run the pump with the gas ballast control in position 'I' or 'II' for 20 minutes before switching to position '0'. If moisture is allowed to remain, the performance of the pump will be impaired.

5.4 To pump condensable vapours (if gas ballast fitted)

Select a suitable gas ballast setting (gas ballast control in position 'I' or 'II') when there is a high proportion of condensable vapours in the process gases. This will assist the vapours to pass through the pump without condensing and keep the pump performance from degrading.

5.5 Implication of ATEX directive

5.5.1 Flammable/pyrophoric materials

When flammable or pyrophoric materials are present within the equipment:

- Do not allow air to enter the equipment.
- Ensure the system is leak tight.
- Dilute any flammable gases or vapours by using an inert purge, for example nitrogen, to the pump inlet and gas ballast (if fitted) to reduce the concentration of flammable gases or vapours in the pump and exhaust line to less than one quarter of the published Lower Explosive Limits (LEL).
- Prevent the condensation of flammable vapours within the pump mechanism and exhaust line by using an inert gas purge to the pump gas ballast connection. Note that this option is not available on the No Gas Ballast versions. In these pumps only inlet purge can be used.

5.5.2 Gas purges



WARNING:

If nitrogen purges are used to dilute dangerous gases to safe levels, ensure that the system shuts down if the nitrogen supply to the pump fails.

The following actions must be taken to ensure that the gas being pumped stays out of the flammable range:

- The inert gas purge should be switched on to remove air from the pump and exhaust before the process starts. The purge flow can be switched off at the end of the process only after any remaining flammable gases or vapours have been purged from the pump and exhaust line.
- If liquids that produce flammable vapours could be present in the pump foreline then the inert gas purge to the pump should be left on all the time this liquid is present. Flammable liquids could be present in the foreline as a result of condensation or may be carried over from the process.
- When calculating the flow rate of inert gas required for dilution, consider the maximum flow rate for the flammable gases or vapours that could occur. For example, if a mass flow controller is being used to supply flammable gases to the process, assume that a flow rate for flammable gases that could arise if the mass flow controller is fully open. The inert gas purge flow rate should be continually measured and if the flow rate falls below that required, then the flow of flammable gases or vapours to the pump must be stopped.

The Vacuum Pump and Vacuum System Safety publication P40040100 is available from us or the supplier.

5.6 Remote operation using 15-way D connector

It is possible to operate the pump remotely using the 15-way D type connector fitted on the panel at the side of the pump.

The 15-way D connector is insulated to ensure that it remains protected in the event of a single fault condition.

The controls available are as follows:

- Run/Standby
- Run - (Runs pump at standard speed 100%).
- Standby - (Pump is not running but is ready and awaiting a remote signal for operation).
- Idle - (Runs pump at 67% speed).
- Boost - (Runs pump at 116%) intermittent use only (not for continuous operation). See note below for further information on this mode of operation.
- OK Signal

Figure: Logic interface schematic on page 25 shows which connections to make to enable these functions.

The Run/Standby switch (*Figure: General view on page 9*, item 9) should be in the Standby position for remote operation. The idle and boost modes are only available with remote operation.

To completely remove electrical power from the pump, the plug should be removed from the electrical connector (*Figure: General view on page 9*, item 7).

Note:

Boost operation is not recommended for the pump as a permanent operation mode, as increased bearing loads will reduce the life of the pump bearings. Please consult us if the boost mode is intended to be used as the limits of operation are application dependent.

5.7 Shut down



WARNING:

When the pump has been switched off the fan will continue to run for 1 minute.

Use the procedure below to shut down the pump:

1. If shutting the pump down prior to a period of storage, remove any process gases by running on high flow gas ballast for at least one hour.
2. Close any vacuum system isolation valve to prevent suck-back into the vacuum system (where fitted).
3. Switch off the pump. (When the pump is switched off the fan will continue to run for 1 minute).
4. Vent the pump by the gas ballast control (if fitted) or valve on the inlet.

Figure 5 Logic interface schematic

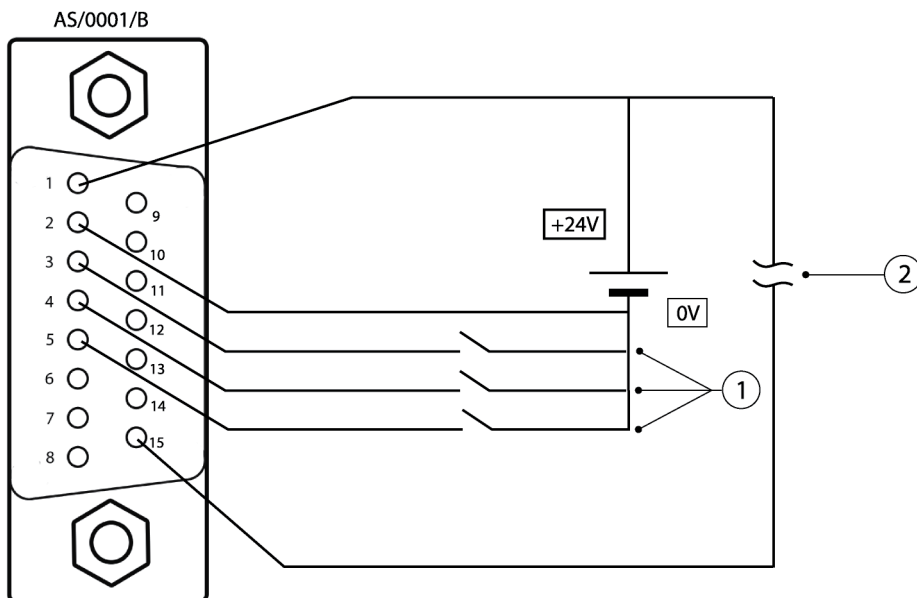

1. Speed control pins 3, 4 and 5
Maximum current per pin = 7 mA when linked to pin 1 (24 V)

2. Pump healthy signal
Signal high = normal (maximum permissible current = 100 mA)

Table 9 Pin status on the logic interface connector

Mode	Speed percentage	Pumping speed (m ³ h ⁻¹)	Pin 1	Pin 3	Pin 4	Pin 5
Normal	100%	35	24 V	Link	open	open
Boost	116%	41	24 V	Link	Link	Link
Idle	67%	23	24 V	Link	Link	open

The tolerance of the power supply can be $\pm 10\%$. Make sure all the unused pins are not connected.

6. Maintenance

6.1 Safety information



WARNING:

Obey the safety instructions in this section and take note of appropriate precautions. Failure to observe these instructions may result in injury to people and damage to equipment.



WARNING:

Wait one minute for capacitor discharge after disconnecting the power supply before working on the pump.



WARNING:

The pump may be contaminated with the process chemicals that have been pumped during operation. If so, ensure that the pump is decontaminated before maintenance and that adequate precautions are taken to protect people from the effects of dangerous substances if contamination has occurred.



WARNING:

Allow the pump to cool to ambient temperature before starting any maintenance work.

The pump is designed to require little user maintenance. Observe the following guidelines when carrying out maintenance on the pump:

- A suitably trained and supervised technician must maintain the pump.
- Ensure that the maintenance technician is familiar with the safety procedures that relate to the products processed by the pumping system.
- Wear the appropriate safety clothing when coming into contact with contaminated components.
- Dismantle and clean contaminated components inside a fume cupboard.
- Do not reuse O-rings or seals.
- Isolate the pump and other components from the electrical supply so that they cannot be operated accidentally.
- After maintenance has been completed, re-check the direction of pump rotation if the electrical supply has been disconnected.
- Check all required components are available and are of the correct type before starting work.
- Leak test the system after installation is complete and seal any leaks found to prevent leakage of hazardous substances out of the system and leakage of air into the system.
- Protect sealing faces from damage.

- Do not touch or inhale the thermal breakdown products of fluorinated materials which may be present in the pump if the pump has been heated to 260 °C and above. Fluorinated materials are safe in normal use but can decompose into very dangerous substances (which may include hydrofluoric acid) if they are heated to 260 °C and above. The pump may have overheated if misused or in a fire. Safety Data Sheets for fluorinated materials used in the pump are available on request, contact us or the supplier.

6.2 Maintenance plan

The plan shown in [Table: Maintenance plan on page 27](#) details the routine maintenance operations necessary to maintain the pump in normal use. Instructions for each operation are given in the section shown.

More frequent maintenance may be required if the pump is used to pump corrosive or abrasive gases and vapours.

Table 10 Maintenance plan

Operation	Frequency	Refer to Section
Inspect and clean inlet strainer	Annually	Inspect and clean the inlet strainer on page 27
Inspect and clean the gas ballast control (if fitted)	Annually	Inspect and clean the gas ballast control (if fitted) on page 28
Clean the external fan cover	Annually	Clean the external fan cover on page 29
Replace the tip seal and exhaust valve	Annually or as required	Replace the tip seals on page 29
Test the motor/drive condition	15000 hours	Test the motor condition on page 29
Replace the bearings	35000 hours	Contact us

6.3 Inspect and clean the inlet strainer

Whenever disconnecting the pump from the vacuum system:

- Remove any debris trapped by the inlet strainer (in the inlet port).
 - Inspect the inlet strainer and if necessary, clean with a cleaning solution suitable for the substances pumped. Refit the inlet strainer before reconnecting the pump to the vacuum system.
- Refer to [Figure: Inlet strainer assembly on page 28](#). Disconnect the vacuum system from the pump inlet port (item 3) and remove the centring ring and strainer assembly (item 1) and the O-ring (item 2). Inspect the centring ring and the O-ring. If clean, continue at Step 5. If not clean, continue at Step 2.
 - Remove the O-ring (item 2) from the centring ring and strainer assembly (item 1). Do not allow the O-ring to come into contact with the cleaning solution.
 - Wash the centring ring and strainer assembly in a suitable cleaning solution and allow it to dry.
 - If necessary, wipe the O-ring with a clean, dry, lint-free cloth.

- Refit the centring ring and strainer assembly and the O-ring to the inlet port. Refit the vacuum system to the pump inlet port.

Figure 6 Inlet strainer assembly

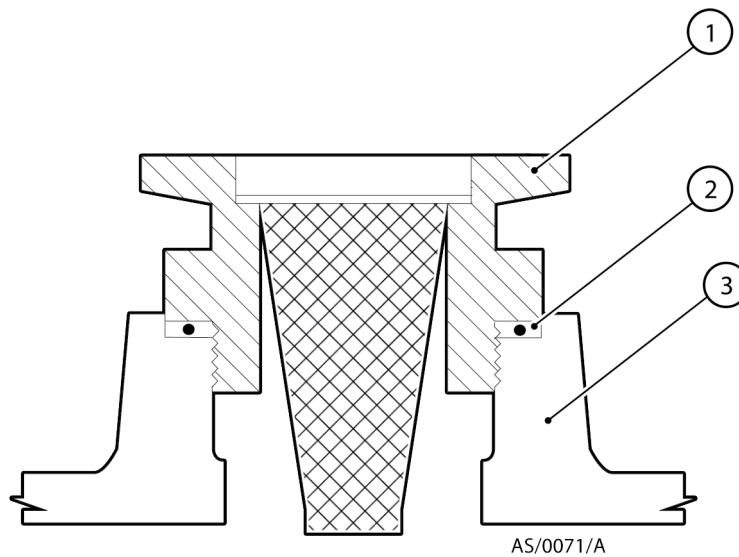

- | | |
|---|--|
| <ol style="list-style-type: none"> Centring ring and strainer O-ring Pump inlet port | <ol style="list-style-type: none"> |
|---|--|

6.4 Inspect and clean the gas ballast control (if fitted)

 **Note:**

The gas ballast filter element (*Figure: Gas ballast control assembly on page 29, item 7*) is retained in its seating with adhesive, do not try to remove it.

- Refer to *Figure: Gas ballast control assembly on page 29*. Turn the gas ballast control to the high flow position (II).
- Push the control down against the compression spring (item 6) as far as it will go, then turn the control anti-clockwise slightly to release the bayonet lugs (item 5) and remove the control (item 1).
- If necessary, wipe the control with a clean, dry, lint-free cloth and check that the air hole (item 3) is not blocked.
- Refit the control into the gas ballast inlet and ensure that the compression spring locates correctly between the bayonet lugs.
- Push the control down as far as it will go and then turn the control clockwise slightly until the bayonet lugs engage correctly.
- Reset the gas ballast control to the required position.

Figure 7 Gas ballast control assembly

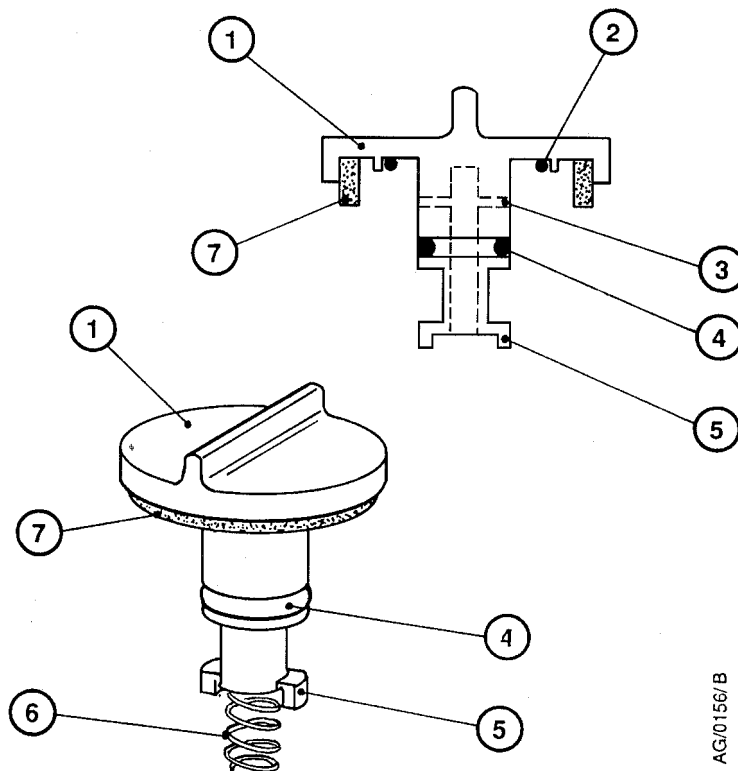

- | | |
|------------------------|-----------------------|
| 1. Gas ballast control | 2. O-ring |
| 3. Air hole | 4. O-ring |
| 5. Bayonet lugs | 6. Compression spring |
| 7. Filter element | |

6.5 Clean the external fan cover

If the fan cover is not kept clean, the air flow over the pump can be restricted and the pump may overheat.

1. Switch off the pump and disconnect it from the electrical supply.
2. Use a dry cloth and a soft brush to remove dirt and deposits from the fan cover.

6.6 Replace the tip seals

This instruction is applicable to the replacement tip seal kit (contained in minor service kit, refer to [Service kits on page 36](#)) that must be fitted.

6.7 Test the motor condition



CAUTION:

Do not flash test the pump or damage to the inverter may result.

Test the earth continuity and the insulation resistance of the pump motor, in accordance with local regulations for the periodic testing of electrical equipment.

We recommend that the earth continuity is less than 0.1 Ω and the insulation resistance is greater than 2 M Ω . (Reference EN61010-1).

If the pump fails these tests, contact us.

7. Fault finding

7.1 The pump has failed to start or has stopped

- The electrical supply fuse has blown.
- The electrical supply voltage does not match that for which the inverter input has been configured.
- The inverter drive has not reset after an over temperature event. Disconnect the mains supply and wait for at least one minute and attempt to restart.
- The motor is faulty.
- Fan not working or not connected.
- The ambient temperature is too high.
- The cooling air supply is insufficient or is too hot.
- The process gas is too hot or the throughput is too high.

7.2 The pump has failed to achieve the required performance

- The pump gas ballast may be selected. To close the gas ballast (if fitted), turn the control to position '0'. Use this setting in order to achieve the best possible vacuum. If the pump has been used to pump condensable vapours or is to pump a large chamber that has been exposed to atmospheric air (water vapour), it may be necessary to run for at least an hour on high flow gas ballast 'II'.
- If the electrical supply voltage is more than 10% below the lowest voltage specified on the voltage indicator, the pump may operate yielding a degraded vacuum performance.
- There is a leak in the vacuum system.
- The pressure measurement technique or gauge head is unsuitable or gives an incorrect indication of pressure.
- The vacuum fittings are dirty or damaged.
- The inlet strainer is blocked.
- There is a blockage or high pressure in the exhaust line.
- The pump contains traces of process vapours.
- The pump is outside the specified range of operating conditions.
- The gas ballast control (if fitted) is not properly closed.
- The tip seals need replacing.
- The inverter is current limiting the supply.
- The pump is in idle mode.

7.3 The pump is noisy

- The pump is contaminated with solid particles.
- The bearings are worn.
- Following tip seal replacement, the pump has not been vented and a build-up of eroded tip seal dust is reducing running clearances. Refer to [Replace the tip seals on page 29](#) for further information.

7.4 The pump surface temperature is high

- The ambient temperature is too high.
- The cooling air supply is insufficient or is too hot.
- The process gas is too hot or the maximum continuous operating pressure has been exceeded.

7.5 The pumping speed is poor or if pump down time is too long

- The connecting pipelines are too small in diameter.
- The connecting pipelines are too long.
- The inlet strainer is blocked.
- There is a leak in the system.
- The inverter is current limiting the supply.
- The pump is in idle mode.

8. Storage and disposal

8.1 Storage

Use the following procedure to store the pump:

1. Shut down the pump as described in [Shut down on page 25](#).
2. Disconnect the pump from the electrical supply.
3. Place and secure protective covers over the inlet and outlet ports.
4. Store the pump in cool, dry conditions until required for use. When required, prepare and install the pump as described in [Installation on page 16](#).

8.2 Disposal



WARNING:

Do not incinerate fluoroelastomer or perfluoroelastomer seals, tip seal material or O-rings.

Dispose the pump and any components removed from it safely in accordance with all local and national safety and environmental requirements.

Take particular care with components and waste oil which have been contaminated with dangerous process substances.

9. Service and spares

9.1 Introduction

Our products, spares and accessories are available from our companies in Belgium, Brazil, China, France, Germany, Israel, Italy, Japan, Korea, Singapore, United Kingdom, U.S.A and a world-wide network of distributors. The majority of these centres employ service engineers who have undergone our comprehensive training courses.

Order spare parts and accessories from our company or distributor. When ordering, state for each part required:

- Model and Item Number of the equipment.
- Serial number.
- Item number and description of part.

9.2 Accessories

 **Note:**

Accessories could affect the safety of the product. It is recommended that our standard accessories are used.

9.2.1 Electrical cables

Electrical cables are available as accessories and should be used to connect the pump to the electrical supply:

See [Electrical data on page 14](#) for details.

9.2.2 Silencer

A silencer is available for the pump. The code number for the silencer is A50597001. A silencer spares kit, code number A50597801 is also available.

The power consumption during large chamber pump down can be reduced by up to 100 W at high inlet pressures by installation of a second silencer by an NW25 T-piece to the exhaust port.

9.2.3 Gas ballast adaptor

Fit the gas ballast adaptor in place of the gas ballast control on the pump. The adaptor allows for connection a controlled supply of inert gas to the pump. Gas ballast adaptor A50502000.

9.2.4 Solenoid operated pipeline valves

Fit the pipeline valve between the vacuum system and the pump inlet to provide additional system protection when the pump is switched off. The following valves are available as an accessory and are recommended.

Table 11 Solenoid operated pipeline valves

Product description	Ordering information
PV40EK Valve, 220-240 V 50-60 Hz, Aluminium	C41401000
PV40EK Valve, 220-240 V 50-60 Hz, Steel	C41402000
PV40EK Valve, 110-127 V 50-60 Hz, Aluminium	C41403000
PV40EK Valve, 110-127 V 50-60 Hz, Steel	C41404000

9.3 Service

Our products are supported by a worldwide network of our service centres. Each service centre offers a wide range of options including equipment decontamination, service exchange, repair, rebuild and testing to factory specifications. Equipment which has been serviced, repaired or rebuilt is returned with a full warranty.

The local service centre can also provide our engineers to support on-site maintenance, service or repair of the equipment.

For more information about service options, contact the nearest service centre or our company.

9.3.1 Return the equipment or components for service

Before you send your equipment to us for service or for any other reason, you must send us a completed Declaration of Contamination of Vacuum Equipment and Components – Form HS2. The HS2 form tells us if any substances found in the equipment are hazardous, which is important for the safety of our employees and all other people involved in the service of your equipment. The hazard information also lets us select the correct procedures to service your equipment.

We provide instructions for completing the form in the Declaration of Contamination of Vacuum equipment and Components – Procedure HS1.

If you are returning a vacuum pump, note the following:

- If a pump is configured to suit the application, make a record of the configuration before returning the pump. All replacement pumps will be supplied with default factory settings.
- Do not return a pump with accessories fitted. Remove all accessories and retain them for future use.
- The instruction in the returns procedure to drain all fluids does not apply to the lubricant in pump oil reservoirs.

Download the latest documents from www.edwardsvacuum.com/HSForms/, follow the procedure in HS1, fill in the electronic HS2 form, print it, sign it, and return the signed copy to us.



NOTICE:

If we do not receive a completed HS2 form, your equipment cannot be serviced.

9.4 Service kits

9.4.1 Tip seal and exhaust service kit

The kit, part number is A73001801, contains all the necessary components to replace the tip seal and exhaust valve. Tip seals should be replaced as a pair and only simple tools are required. This kit is suitable for XDS35i and XDS35iE.

Same kit is available for chemical resistance version of pumps XDS35iC and XDS35iCE under part number A73008801.

A chemical resistance exhaust valve kit can be purchased separately under part number A73001814.

9.4.2 Bypass valve kit

The kit, part number A73003804, contains 3 sets of valve pad, spring and O-ring for replacement the by-pass valves. This kit is suitable for XDS35iE

Same kit is available for chemical resistance version of pumps XDS35iC and XDS35iCE under part number A73008804.

9.4.3 Gas ballast kit

The kit, part number A73001803, contains all the necessary components for exchanging gas ballast valve. This kit is suitable for XDS35i (Gas Ballast version)

Same kit is available for chemical resistance version of pumps XDS35iC and XDS35iCE under part number A73001815.

