

E1M18 and E2M18 Rotary Vacuum Pumps

INSTRUCTION MANUAL



edwardsvacuum.com



DESCRIPTION	ITEM NUMBER
E1M18, 100/200 V, 50 Hz or 100-105/200-210 V, 60 Hz, single-phase	A34315904
E1M18, 115/230 V, 60 Hz, single-phase	A34315981
E1M18, 220-240 V, 50 Hz, or 230-240 V, 60 Hz, single-phase	A34315903
E1M18, 200-230/380-460 V, 50/60 Hz, three-phase	A34310940
E1M18, 220-240 V, 50 Hz, or 230-240 V, 60 Hz, single-phase (Amphenol)	A34316903
E1M18, 110/200-240 V, 50 Hz, or 115-120/200-230 V, 60 Hz, single-phase	A34317984
E1M18, 110/200-240 V, 50 Hz, or 115-120/200-230 V, 60 Hz, single-phase, fomblin filled	A34325984
E2M18, 100/200 V, 50 Hz or 100-105/200-210 V, 60 Hz, single-phase	A36315904
E2M18, 115/230 V, 60 Hz, single-phase	A36315981
E2M18, 220-240 V, 50 Hz, or 230-240 V, 60 Hz, single-phase	A36315903
E2M18, 200-230/380-460 V, 50/60 Hz, three-phase	A36310940
E2M18, 110/200-240 V, 50 Hz, or 115-120/200-230 V, 60 Hz, single-phase	A36317984
E2M18-FF, 200-230/380-460 V, 50/60 Hz, three-phase	A36321940
E2M18-FF, 100/200 V, 50/60 Hz, single-phase	A36325904
E2M18, 220-240 V, 50 Hz, single-phase	A36325912
E2M18, 110/200-240 V, 50 Hz, or 115-120/200-230 V, 60 Hz, single-phase, fomblin filled	A36325984

Copyright notice

©Edwards Limited 2020. All rights reserved.

Associated publications

Publication title	Publication number
Vacuum pump and vacuum system safety	P40040100
Vibration isolators	A24801880
EMF3, EMF10 and EMF20 oil mist filters	A46226880

Trademark credit

Edwards and the Edwards logo are trademarks of Edwards Limited, Innovation Drive, Burgess Hill, West Sussex RH15 9TW.

Disclaimer

The content of this manual may change from time to time without notice. We accept no liability for any errors that may appear in this manual nor do we make any expressed or implied warranties regarding the content. As far as practical we have ensured that the products have been designed and constructed to be safe and without risks when properly installed and used in accordance with their operating instructions.

We accept no liability for loss of profit, loss of market or any other indirect or consequential loss whatsoever.

Product warranty and limit of liability are dealt with in our standard terms and conditions of sale or negotiated contract under which this document is supplied.

You must use this product as described in this manual. Read the manual before you install, operate, or maintain the product.

CE Declaration of Conformity

Edwards Ltd
 Innovation Drive
 Burgess Hill
 West Sussex
 RH15 9TW
 UK

The following product

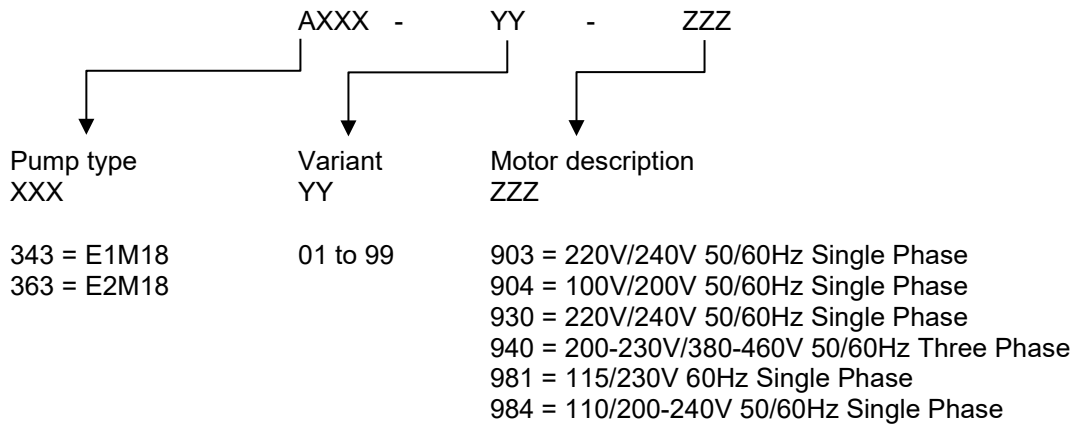

Is in conformity with the relevant requirements of European CE legislation:

2006/42/EC	Machinery directive
2014/34/EU	ATEX directive on use in potentially explosive atmospheres. Intertek Testing and Certification Limited, 0359 Intertek House, Cleeve Road, Leatherhead, Surrey, KT22 7SB
ATEX marking:	 II 3 G Ex h IIB T4 Gc INTERNAL ATMOSPHERES ONLY TCF 218
2011/65/EU	Restriction of certain hazardous substances (RoHS) directive as amended by Delegated Directive (EU) 2015/863

Based on the relevant requirements of harmonised standards:

EN 1012-2:1996 +A1:2009	Compressors and vacuum pumps. Safety requirements. Vacuum pumps
EN 61010-1:2010 *	Safety requirements for electrical equipment for measurement, control and laboratory use. General requirements
* 1-phase pumps only	<i>The pumps comply with EN 61010-1 when installed in accordance with the instruction manual supplied with the pumps.</i>
EN ISO 80079-36:2016	Explosive atmospheres – Part 36: Non-electrical equipment for explosive atmospheres. Basic method and requirements
EN ISO 80079-37:2016	Explosive atmospheres - Part 37: Non-electrical equipment for explosive atmospheres -- Non-electrical type of protection constructional safety "c", control of ignition sources "b", liquid immersion "k"

Documentation Officer: Jelena Havelkova, Spielberg Office Centre, Holandska 10, Brno, 63900 Czech Republic,
☎: +42(0) 734 418 896, ✉: documentation@edwardsvacuum.com

This declaration, based on the requirements of the listed Directives and EN ISO/IEC 17050-1, covers all product serial numbers from this date on: *21st May 2020*.



*Petr Smerek – Engineering Manager
Scientific Vacuum Division
Lutin, CZ*



*Nina Buta – General Manager
Lutin, CZ*

Additional Legislation and Compliance Information

EU RoHS Directive: Material Exemption Information

This product is compliant with the following Annex III Exemptions

- 6(b) **Lead** as an alloying element in aluminium containing up to 0.4% by weight
- 6(c) Copper alloy containing up to 4% **lead** by weight

EU REACH Regulation Compliance

This product is a complex article which is not designed for intentional substance release. To the best of our knowledge the materials used comply with the requirements of REACH. The product manual provides information and instruction to ensure the safe storage, use, maintenance and disposal of the product including any substance based requirements.

Article 33.1 Declaration

This product does contain Candidate List Substances of Very High Concern above 0.1%ww by article as clarified under the 2015 European Court of Justice ruling in case C-106/14.

- Lead (Pb) added to the Candidate List June 2018

As indicated by the applied RoHS exemption(s) above this substance is present in certain aluminium and brass components.

ADDITIONAL INFORMATION

The products listed are also in scope for and comply with the requirements of the following:

2012/19/EU	Directive on waste electrical and electronic equipment (WEEE)
CSA-C22.2 No.77-2014 #	Motors with inherent overheating protection
CSA-C22.2 No.100-2014 #	Motors and generators
Product is certified to CSA-C22.2 No.61010-1-12	Safety requirements for electrical equipment for measurement, control and laboratory use – Part 1: General requirements
Product conforms to UL61010-1 3 rd Edition	Safety requirements for electrical equipment for measurement, control and laboratory use – Part 1: General requirements
# 1- phase pumps only	Canadian Standards Authority and Underwriters Laboratory

材料成分声明

China Material Content Declaration

部件名称 Part name	有害物质 Hazardous Substances					
	铅 Lead (Pb)	汞 Mercury (Hg)	镉 Cadmium (Cd)	六价铬 Hexavalent Chromium (Cr VI)	多溴联苯 Polybrominated biphenyls (PBB)	多溴二苯醚 Polybrominated diphenyl ethers (PBDE)
铸铝及铝合金制品 Aluminium alloys	X	O	O	O	O	O
铜接头 Brass connectors	X	O	O	O	O	O

O: 表示该有害物质在该部件的所有均质材料中的含量低于 GB/T 26572 标准规定的限量要求。

O: Indicates that the hazardous substance contained in all of the homogeneous materials for this part is below the limit requirement in GB/T 26572.

X: 表示该有害物质在该部件的至少一种均质材料中的含量超出 GB/T26572 标准规定的限量要求。

X: Indicates that the hazardous substance contained in at least one of the homogeneous materials used for this part is above the limit requirement of GB/T26572.

This page has been intentionally left blank.

Contents

1. Safety and compliance.	7
1.1 Definition of Warnings and Cautions.	7
1.2 Safety symbols.	7
2. Introduction.	9
2.1 Scope and definitions.	9
2.2 ATEX directive implications.	9
2.3 Description.	9
2.4 Gas-ballast.	11
3. Technical data.	13
3.1 Operating and storage conditions.	13
3.2 Performance.	13
3.3 Mechanical data.	14
3.4 Lubrication data.	16
3.5 Electrical data.	17
4. Installation.	19
4.1 Safety.	19
4.2 System design.	19
4.3 Unpack and inspect.	20
4.4 Locate the pump.	20
4.5 Fill the pump with oil.	21
4.6 Electrical installation: single-phase motors.	21
4.6.1 Standard single-phase motors.	22
4.6.2 Amphenol version single-phase motors.	23
4.6.3 110/200-240 V 50 Hz or 115-120/200-230 V 60 Hz single-phase motors.	23
4.7 Electrical installation: three-phase motors.	26
4.7.1 Connect the electrical supply to the motor.	26
4.7.2 Check the direction of rotation.	27
4.8 Connect the pump inlet.	28
4.9 Connect the pump outlet.	29
4.10 Gas-ballast inlet connection.	29
4.11 Leak-test the system.	30
5. Operation.	31
5.1 ATEX directive implications.	31
5.1.1 Flammable/pyrophoric materials.	31
5.1.2 Gas purges.	32

5.2 Gas-ballast control.	32
5.3 Start-up.	33
5.4 To achieve ultimate vacuum.	33
5.5 To pump condensable vapours.	34
5.6 To decontaminate the oil.	34
5.7 Unattended operation.	34
5.8 Shut-down.	35
6. Maintenance.	36
6.1 Safety information.	36
6.2 Maintenance plan.	37
6.3 Check the oil level.	37
6.4 Replace the oil.	38
6.5 Inspect and clean the inlet-filter.	38
6.6 Clean the gas-ballast filter.	39
6.7 Clean the motor fan-cover and enclosure.	40
6.8 Clean and overhaul the pump.	40
6.9 Replace the run capacitor and test the motor.	40
6.10 Fit new blades.	40
7. Fault finding.	41
7.1 The pump has failed to start.	41
7.2 The pump fails to achieve specified performance (failure to reach ultimate vacuum).	41
7.3 The pump is noisy.	41
7.4 The pump surface temperature is above 100 °C.	42
7.5 The vacuum is not maintained after the pump is switched off.	42
7.6 The pumping speed is poor.	42
7.7 There is an external oil leak.	42
8. Storage.	43
9. Disposal.	44
10. Spares and accessories.	45
10.1 Spares.	45
10.2 Accessories.	46
10.2.1 Inlet catchpot.	47
10.2.2 Inlet dust filter.	47
10.2.3 Inlet desiccant trap.	47
10.2.4 Inlet chemical trap.	47
10.2.5 Outlet mist filter.	47
10.2.6 Solenoid operated pipeline valve.	48
10.2.7 Foreline trap.	48

10.2.8	Vibration isolators.	48
10.2.9	Oil drain extension.	48
10.2.10	Pump inlet adaptor.	48
10.2.11	Flexible bellows.	48
10.2.12	Pump outlet adaptor.	48
10.2.13	Gas ballast banjo/elbow assembly.	48
10.2.14	Gas ballast valve.	48
11.	PFPE-prepared EM pumps.	49
11.1	Installation.	49
11.2	Operation.	49
11.3	Maintenance.	49
12.	Service.	51
12.1	Return the equipment or components for service	51

List of Figures

Figure 1: General view of the pump.	11
Figure 2: Single-phase motors: Dimensions mm (inches).	15
Figure 3: Three-phase motors: Dimensions mm (inches).	16
Figure 4: Single-phase motors: 220-240 V 50 Hz and 230-240 V 60 Hz.	24
Figure 5: Single-phase motors: 100 V 50 Hz, 100-105 V 60 Hz and 115 V 60 Hz.	24
Figure 6: Single-phase motors: 200 V 50 Hz, 200-210 V 60 Hz and 230 V 60 Hz.	25
Figure 7: Single-phase motors with Amphenol connector: 220-240 V 50 Hz and 230-240 V 60 Hz.	25
Figure 8: Motor voltage selection: single-phase motors, 110/200-240 V 50 Hz and 115-120/200-240 V 60 Hz.	26
Figure 9: Electrical supply connection, three-phase motors: 200-220 V 50 Hz and 200-230 V 60 Hz.	28
Figure 10: Electrical supply connection, three-phase motors: 380-415 V 50 Hz and 460 V 60 Hz.	29
Figure 11: Remove/replace the inlet filter.	39
Figure 12: Remove/replace the gas-ballast filter.	40
Figure 13: Accessories.	46

1. Safety and compliance

1.1 Definition of Warnings and Cautions

NOTICE:



This manual meets our obligation to provide you with information. For safe operation from the start, read these instructions carefully before you install or commission the equipment.

Read all the safety instructions in this section and the rest of this manual carefully and make sure that you obey these instructions. The equipment must only be operated and maintained by trained personnel in the proper condition and as described in this instruction manual.

Obey local and state requirements and regulations. If you have any questions about safety, operation or maintenance of the device, please contact our nearest subsidiary.

Important safety information is highlighted as warning and caution instructions. Obey these instructions.



WARNING:

If you do not obey a warning, there is a risk of injury or death. Different symbols are used according to the type of hazard.



CAUTION:

If you do not obey a caution, there is a risk of minor injury, damage to equipment, related equipment or process.



NOTICE:

Information about properties or instructions for an action which, if ignored, will cause damage to the pump or the system.





We reserve the right to change the design and the stated data. The illustrations are not binding.

Keep the instructions for future use.

1.2 Safety symbols

The units used throughout this manual conform to the SI international system of units of measurement.

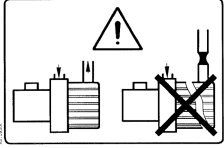
The following warning labels may be present on the pump and used throughout the product documentation:

	Warning - refer to accompanying documentation.
	Warning - risk of electric shock.
	Warning - hot surfaces.
	Warning - do not block the pump outlet
	Warning - use protective equipment. Indicates that protective equipment must be used.

2. Introduction

2.1 Scope and definitions

This manual provides installation, operation and maintenance instructions for our rotary vacuum pumps. The pump must be used as specified in this manual.

Read this manual before installing and operating the pump.

2.2 ATEX directive implications



This equipment is designed to meet the requirements of Group II Category 3 equipment in accordance with Directive 2014/34/EU of the European Parliament and the Council of 26th February 2014 on the approximation of the laws of the Member States concerning equipment and protective systems intended for use in potentially explosive atmospheres. (The ATEX Directive).

The ATEX Category 3 applies in respect of potential ignition sources internal to the equipment. An ATEX Category has not been assigned in respect of potential ignition sources on the outside of the equipment as the equipment has not been designed for use where there is an external potentially explosive atmosphere. There is no potential source of ignition within the pump during normal operation but there may be potential sources of ignition under conditions of predictable and rare malfunction as defined in the Directive.

There is no potential source of ignition within the pump during normal operation but there may be potential sources of ignition under conditions of predictable and rare malfunction as defined in the Directive. Accordingly, although the pump is designed to pump flammable materials and mixtures, operating procedures should ensure that under all normal and reasonably predictable conditions, these materials and mixtures are not within explosive limits. Category 3 is considered appropriate for the avoidance of ignition in the case of a rare malfunction which allows flammable materials or mixtures to pass through the pump while within their explosive limits.

When flammable or pyrophoric materials are present within the equipment:

- Do not allow air to enter the equipment.
- Ensure that the system is leak tight.

For further information, please contact us: refer to our website www.edwardsvacuum.com for details of your nearest company.

2.3 Description

Refer to *Figure: General view of the pump on page 11* for item numbers in brackets in the following descriptions.

The E1M18 and E2M18 pumps are direct drive, sliding vane pumps. The E1M18 is a single-stage pump and the E2M18 is a two-stage pump. The pump is oil-sealed and designed for reliable, long-term operation in both laboratory and industrial environments. The pump is a free-standing unit. The drive is provided through a flexible coupling by a single-phase or three-phase (four pole) motor. The motors are totally enclosed and are cooled by the motor-cooling fan which directs air along the motor fins.

The single-phase motors have a thermal overload device. When the motor is too hot, the thermal overload device switches off the pump. The thermal overload device has an automatic reset; when the motor cools down, the device resets and the motor will restart. The single phase motors have an on/off switch.

An oil pressure system lubricates the pump shaft bearing surfaces and rotor sealing faces. The pump has an oil distribution valve which prevents discharge of oil to the pump interior (suckback) after the pump stops. The pumping chambers are air-tight, so this arrangement prevents air suckback unless the gas-ballast valve is open. For protection in this case, refer to [Gas-ballast on page 11](#).

The level and condition of oil in the oil box reservoir can be inspected through the oil sight-glass. An oil filler-plug is fitted to the top of the oil box. The pump has an oil drain-plug to allow gravity oil drain.

The pump has an inlet-port, outlet nozzle and gas-ballast control. The pump is mounted on two mild steel box section skids on rubber pads. Details of suitable vibration isolators and other recommended accessories are given in [Accessories on page 46](#).

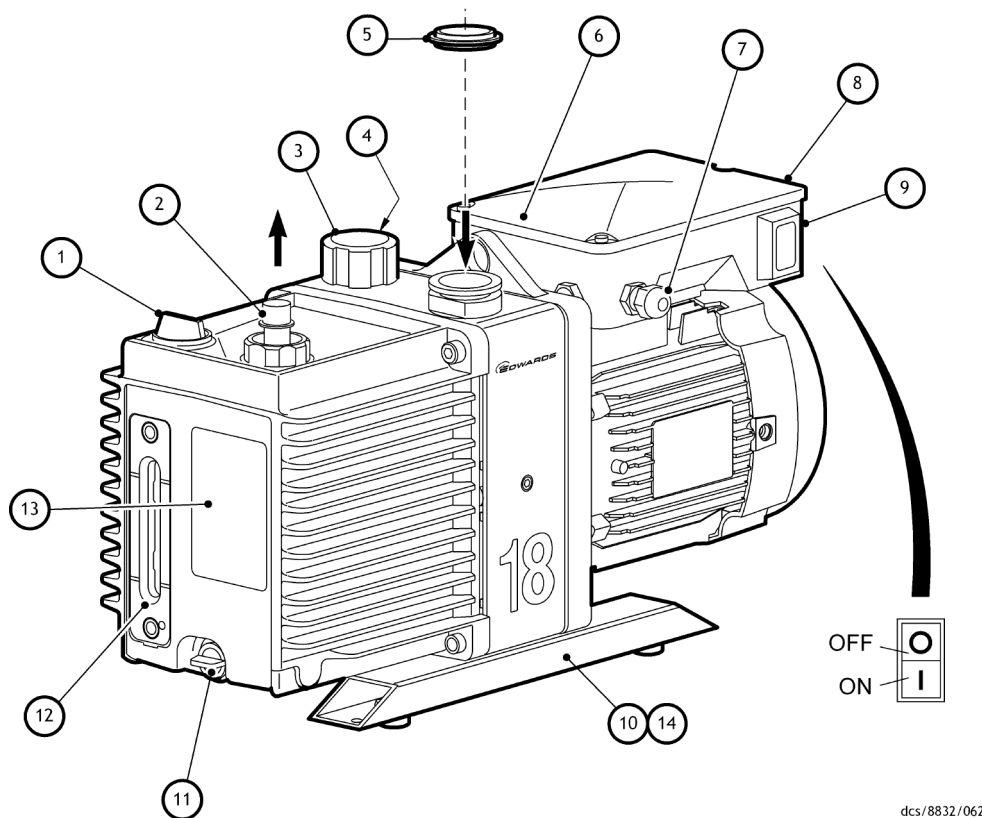
Figure 1 General view of the pump

dcs/8832/062

- | | |
|--|--------------------------------|
| 1. Oil filler | 2. Outlet nozzle |
| 3. Gas-ballast control | 4. Gas-ballast inlet |
| 5. Centring-ring and O-ring (supplied) | 6. Inlet-port (adaptor flange) |
| 7. Cable-gland/Amphenol connector position | 8. Motor terminal box |
| 9. On/Off switch | 10. Box section skids |
| 11. Oil drain-plug (gravity drain) | 12. Oil sight-glass |
| 13. Pump identification label | 14. Oil drip tray |

Note:

A pump with a single-phase motor is shown in this figure. The motor shown in this figure is not representative of the motor used on the E1/E2M18 pumps with Item Numbers A34317984 and A36317984. On these pumps, Cable-gland/Amphenol connector position and On/Off switch are transposed, with Cable-gland/Amphenol connector position being an IEC60320 16-20 Amp socket.

2.4 Gas-ballast

When using the pump with high vapour throughputs, the gas-ballast facility should be used to prevent condensation of the vapours inside the pump. The condensates will contaminate the oil, will cause performance to deteriorate and may cause corrosion of the pump mechanism.

Air (or an inert gas) can be introduced into the pump mechanism through the gas-ballast control (*Figure: General view of the pump on page 11*).

The gas-ballast control is a multi-turn valve:

- From the closed position, the first two turns of the gas-ballast control provide an additional oil-feed to the pump mechanism, but do not introduce gas-ballast into the pump. The additional oil-feed improves the lubrication and sealing of the pump mechanism.
- With further turns of the gas-ballast control, the gas-ballast flow into the pump increases from zero flow, until the valve is fully open.

3. Technical data

3.1 Operating and storage conditions

 **Note:**

To comply with EN 61010 and CSA standards, the pump must be installed and used indoors and within the operating conditions specified in [Table: Operating and storage conditions on page 13](#).

Table 1 Operating and storage conditions

Parameter	Reference data
Ambient temperature range (operation)	13 to 40 °C
Ambient temperature range (storage)	- 30 to 70 °C
Normal surface temperature of the pump-body*	45 to 65 °C
Maximum humidity (operation)	90% RH
Maximum altitude (operation)	2000 m
Pollution degree	2
Installation category	II
Noise level at 1 metre	57 dB(A) (at 50 Hz)
Vibration severity†	Class 1C

* At ultimate vacuum, with ambient temperature of 20 °C.

† Measured at the inlet port to ISO 2372 (1974).

3.2 Performance

 **Note:**

Where total pressures are shown in [Figure: Dimensions \(mm\) on page 15](#) below, measurements were taken using an untrapped total pressure capacitance diaphragm gauge on a header, as specified by Pneurop standards.

Table 2 Performance data

Parameter	Data	
	E1M18	E2M18
Maximum displacement		
50 Hz electrical supply	20.5 m ³ h ⁻¹	20.5 m ³ h ⁻¹
60 Hz electrical supply	25.0 m ³ h ⁻¹	25.0 m ³ h ⁻¹
Maximum pumping speed - Pneurop		
50 Hz electrical supply	17.0 m ³ h ⁻¹	17.0 m ³ h ⁻¹
60 Hz electrical supply	20.4 m ³ h ⁻¹	20.4 m ³ h ⁻¹

Parameter	Data	
	E1M18	E2M18
Motor rotational speed		
50 Hz electrical supply	1440 r min ⁻¹	1440 r min ⁻¹
60 Hz electrical supply	1720 r min ⁻¹	1720 r min ⁻¹
Ultimate vacuum		
without gas-ballast (partial pressure)	2 x 10 ⁻² mbar 2 Pa	1 x 10 ⁻⁴ mbar 1 x 10 ⁻² Pa
without gas-ballast (total pressure)	3 x 10 ⁻² mbar 3 Pa	1 x 10 ⁻³ mbar 1 x 10 ⁻¹ Pa
with full gas-ballast (partial pressure)	6.5 x 10 ⁻¹ mbar 6.5 x 10 ¹ Pa	5 x 10 ⁻³ mbar 5 x 10 ⁻¹ Pa
Maximum water vapour inlet pressure	50 mbar 5 x 10 ³ Pa	20 mbar 2 x 10 ³ Pa
Maximum water vapour pumping rate	0.65 kg h ⁻¹	0.3 kg h ⁻¹
Maximum permitted outlet pressure (for full pump throughout)	0.5 bar gauge 1.5 bar absolute 1.5 x 10 ⁵ Pa	0.5 bar gauge 1.5 bar absolute 1.5 x 10 ⁵ Pa

3.3 Mechanical data

Table 3 Mechanical data

Approximate pump mass	38 kg (E1M18), 41 kg (E2M18)
Dimensions	Refer to Figure: Dimensions (mm) on page 15
Degree of protection	
Single-phase motors	IP44
Three-phase motors	IP54
Pump inlet port	NW25 (the flange can be removed from the 1 inch BSP threaded hole)
Pump outlet port	15 mm external diameter nozzle (the nozzle can be removed from the 3/4 inch BSP threaded hole)

Figure 2 Single-phase motors: Dimensions mm (inches)

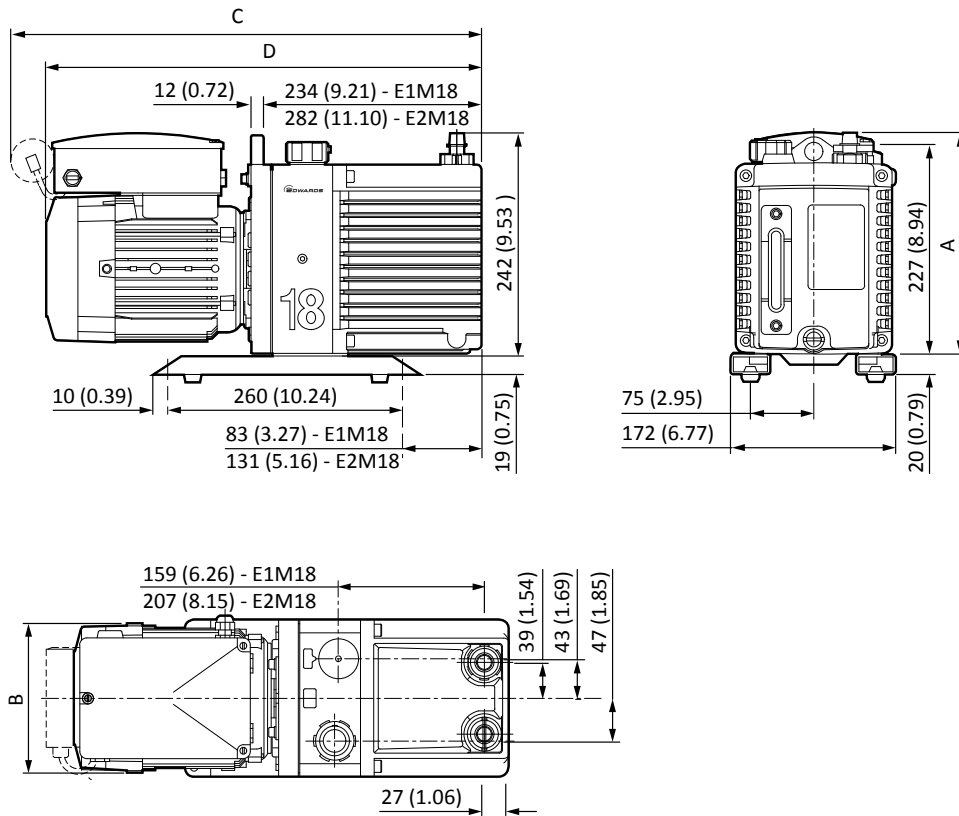

Pump item number	Hz	Dimensions (mm)			
		A	B	C	D
Single-phase motors					
A34315981	60	474	518	241	162
A36315981	60	520	564	241	162
A34315904	50/60	474	518	241	162
A36315904	50/60	520	564	241	162
A36315903, A36317984	50/60	550	-	251	183
A34316903, A34315903, A34317984	50/60	504	-	251	183
A34317984, A36317984	50/60	504	-	251	183

Figure 3 Three-phase motors: Dimensions mm (inches)

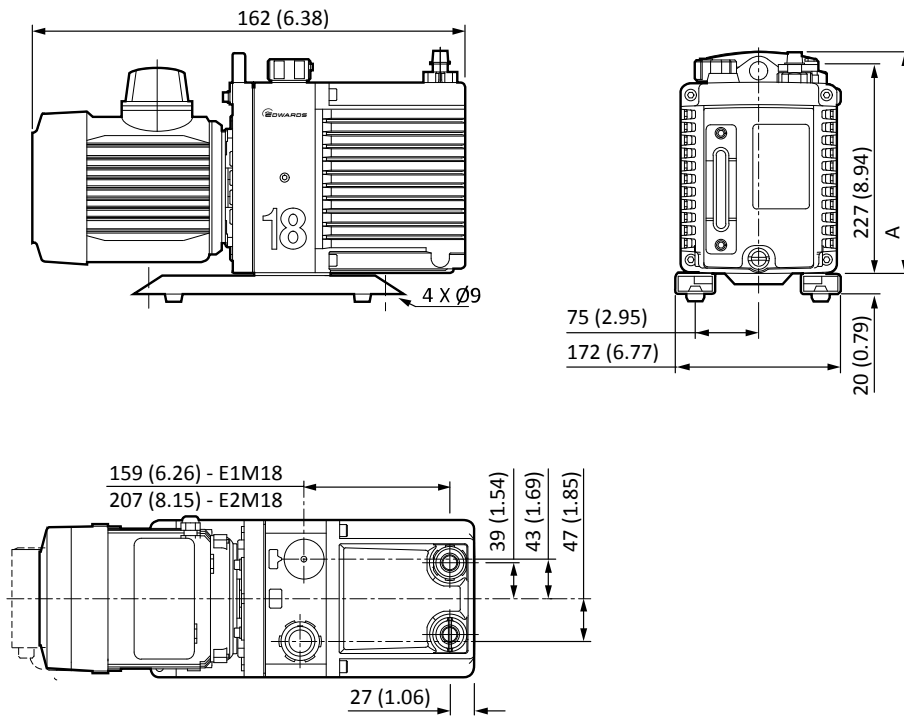

Pump item number	Hz	Dimensions (mm)			
		A	B	C	D
Three-phase motors					
A34310940	50/60	474	-	-	-
A36310940	50/60	520	-	-	-

3.4 Lubrication data

Note:

Manufacturers Material Safety Data Sheets for the oils specified below are available upon request.

Table 4 Lubrication data

Hydrocarbon pumps:	
Recommended oil*	Ultragrade 19
Maximum oil capacity	
E1M18	1.4 litres
E2M18	1.05 litres
PFPE-prepared EM pumps:	
Recommended oil	Krytox 1506 or Fomblin 06/6
Maximum oil capacity	
E1M18	1.4 litres

E2M18	1.05 litres
-------	-------------

* To operate the pump when the ambient temperature is outside the range specified in [Operating and storage conditions on page 13](#) or to optimise pump performance when processing condensable vapours, a different oil may be required.

3.5 Electrical data

Refer to [Table: Electrical data: three-phase motors on page 17](#) and [Table: Electrical data: single-phase motors on page 17](#). For motor current information please refer to the motor rating plate. The motor start-up current is drawn for less than one second, so time-lag fuses must be used to prevent unnecessary fuse failure when the pump starts. Fuses should be to EN60269 [Performance on page 13](#). If using the pump at temperatures lower than 13 °C, the start-up current will be drawn for longer; this may cause the motor thermal overload device to open.

Table 5 Electrical data: three-phase motors

Pump item number	Voltage (V)	Frequency (Hz)	Full load current (A)	Recommended supply protection (A)
A34310940	200 - 220	50	3.3	10
	380 - 415	50	1.9	6
	200 - 230	60	2.3	10
	460	60	1.6	6
A36310940	200 - 220	50	3.3	10
	380 - 415	50	1.9	6
	200 - 230	60	3.4	10
	460	60	1.6	6
Motor output rating (continuous)				
50 Hz operation		0.65 kW		
60 Hz operation		0.75 kW		

Table 6 Electrical data: single-phase motors

Pump item number	Voltage (V)	Frequency (Hz)	Full load current (A)
A36315903, A34316903, A34315903	220 - 240	50	4.6
	230 - 240	60	5.0
A34315981, A36315981	115	60	11.0
	230	60	5.5
A34315904, A36315904	100	50	12.0
	100 - 105	60	11.0
	200	50	6.0
	200 - 210	60	5.5

Pump item number	Voltage (V)	Frequency (Hz)	Full load current (A)
A34317984, A36317984, A34325984, A36325984	110	50	11.0
	115 - 120	60	10.0
	200 - 240	50	5.5
	200 - 230	60	5.0
A34315912, A36315912	220 - 240	50	5.0
A34315920, A36315920	220	50	5.5
	220	60	5.0
Motor output rating (continuous)			
50 Hz operation		0.55 kW or 0.65 kW	
60 Hz operation		0.75 kW	

Table 7 Recommended regional supply protection

Area	Voltage (V)	Rating (A)
UK	230	15
Europe	230	15
USA	110	30
Japan	100	30

Table 8 Recommended cord sets for -984 pump variants and cable specifications

Description	Rating	Coupler type	Item number
Cord set assembly, UK	Cable style = H05VV-F, 3 x 1.5 mm ² , 300 V, 70 °C, maximum length of 2.5 metres Plug type = BS1363 UK plug Appliance coupler = IEC60320 style C14 Fuse type = BS1363 10 Amp fuse, to an IEC60320 style	Straight entry	A50505003
		Right angled entry	A50505006
Cord set assembly, Europe	Cable style = H05VV-F, 3 x 1.5 mm ² , 300 V, 70 °C, maximum length of 2.5 metres Plug type = European Schuko VDE approved, 16 A 250 V rated with dual earthing contact Appliance coupler = IEC60320 style C19	Straight entry	A50506000
		Right angled entry	A50506006
Cord set assembly, USA/Canada (200 - 230 V)	Cable style = SJT, 3 x 14 AWG, 300 V, 90 °C, VW-1 maximum length of 3.0 metres Plug type = NEMA, 6-15P plug Appliance coupler = IEC60320 style C19	-	N/A

4. Installation

4.1 Safety



WARNING:

Ensure that the installation technician is familiar with the safety procedures which relate to the pump oil and the products handled by the pumping system.



WARNING:

If a hydrocarbon oil is used in this pump, do not use the pump to process oxygen in concentrations greater than 25% in volume. If the oxygen concentration is greater than 25%, There is a risk of fire or explosion in the oil-box of the pump.



WARNING:

Do not use the pumps to pump hazardous substances.



WARNING:

Obey the safety instructions listed below and take note of appropriate precautions. Failure to do so can cause injury to people and damage to equipment. Prevent any part of the human body from coming into contact with the vacuum.

- Wear the appropriate safety clothing when coming into contact with contaminated components is anticipated. Dismantle and clean contaminated components inside a fume cupboard.
- Vent and purge the vacuum system before installation work is started.
- Take suitable precautions to avoid the inhalation of oil mist and excessive skin contact with pump oil, as prolonged exposure can be harmful.
- Disconnect the other components in the pumping system from the electrical supply so that they cannot be operated accidentally.
- Safely route any electrical supply cables so that they cannot accidentally trip people.
- Ensure that the pump is suitable for the application. If in doubt as to the suitability of the pump for the application, refer to our guidelines on vacuum pump and vacuum system safety (refer to the Associated Publication at the end of the contents list at the front of this manual) or contact us for advice.

4.2 System design

Consider the following points when designing the pumping system:

- We recommend the use of a foreline vacuum isolation valve to allow the pump to warm up before pumping condensable vapours or if a vacuum needs to be maintained when the pump is not running.

- Avoid high levels of heat input to the pump from the process gases, otherwise the pump may overheat and seize, and cause the motor thermal overload device to open.
- If using the pump in a high ambient temperature with a high gas throughput, the temperature of the pump body may exceed 70 °C. We recommend the use of additional guarding to prevent contact with hot surfaces under these conditions.
- Make sure that the exhaust pipeline cannot become blocked. If an outlet-isolation valve is fitted, make sure the pump cannot be operated with the valve closed.
- Provide for a purge of inert gas when the pumping system is shut down, to dilute dangerous gases to safe concentrations. A suitable gas-ballast control valve for introduction of purge gas into the pump is available as an accessory (refer to [Gas ballast valve on page 48](#)).

Contact our application team for further advice on dilution requirements if required.

4.3 Unpack and inspect

1. Remove all packing materials and protective covers and check the pump. If the pump is damaged, notify the supplier and the carrier in writing within three days; state the item number of the pump together with the order number and the supplier's invoice number. Retain all packing materials for inspection. Do not use the pump if it is damaged.
2. Check that the package contains the items listed. If any of these items are missing, notify the supplier within three days.

If the pump is not to be used immediately, replace the protective covers. Store the pump in suitable conditions, as described in [Storage on page 43](#).

Table 9 Checklist of items

Quantity	Description	Check (✓)
1	E1M18 or E2M18 rotary vacuum pump	<input type="checkbox"/>
(1)	Fitting pack containing the following:	
1	NW25 centring-ring	<input type="checkbox"/>
1	O-ring for centring-ring	<input type="checkbox"/>
1	Receptacle connectors*	<input type="checkbox"/>

* Various sizes: supplied with single-phase motors except for pumps with Item numbers A34316903, A34317984, A36317984, A34325984 and A36325984.

4.4 Locate the pump



WARNING:

Attach mechanical lifting equipment to the eye on the pump. Failure to do so can result in injury to people or damage to the pump. Refer to [Mechanical data on page 14](#) for the mass of the pump.

The pump can be either free-standing on its box section skids, or be fixed by bolts through the four fixing holes in the box section skids, or be used with vibration isolators.

For the locations of the fixing holes in the box section skids refer to [Figure: Dimensions \(mm\) on page 15](#).

Provide a firm, level platform for the pump. Locate the pump so that the oil-level sight-glass is visible and the oil filler-plug, oil drain-plugs and gas -ballast control are accessible.

If the pump will be located inside an enclosure, make sure that there is adequate ventilation at both ends of the pump, so that the ambient temperature around the pump does not exceed 40 °C. There must be a minimum space of 25 mm between the pump and the enclosure walls.

4.5 Fill the pump with oil

Fill the pump with oil as described below. Refer to [Figure: General view of the pump on page 11](#) for the item numbers.

1. Remove the oil filler-plug.
2. Pour oil into the pump until the oil-level reaches the MAX mark on the bezel at the top of the oil sight-glass. If the oil-level goes above the MAX mark, remove the oil drain-plug and drain the excess oil from the pump.
3. After a few minutes, recheck the oil-level. If the oil-level is now below the MAX mark, pour more oil into the pump.
4. Refit the oil filler-plug. Tighten the plug firmly by hand. Do not overtighten.

4.6 Electrical installation: single-phase motors

WARNING:



Ensure that the electrical installation of the pump conforms with the local and national safety requirements. The pump must be connected to a suitably fused and protected electrical supply with a suitable earth (ground) point, for recommended cord sets refer to [Table: Recommended cord sets for -984 pump variants and cable specifications on page 18](#).



CAUTION:

Ensure that the motor is correctly configured for the electrical supply voltage and frequency. If not, damage to the motor can occur.

Note:

The pump will restart automatically when the electrical supply is restored after an interruption and when the pump cools after it has overheated. If the pump is not required to restart automatically, use electrical control equipment which must be reset manually.

Ensure that the electrical supply voltage corresponds with the voltage specified on the motor data plate.

[Table: Electrical data: three-phase motors on page 17](#) gives the recommended fuse rating and [Table: Motor connection details on page 22](#) specifies the correct electrical supply connection details.

The diameter of the outer sheath of the electrical supply cable must be within the range 7 mm to 10.5 mm. The cable must conform in size and colour coding with the local and national electrical installation regulations. The temperature rating of the cable must be 70 °C or greater.

Table 10 Motor connection details

Pump item number	Voltage (V)	Frequency (Hz)	Connection details: refer to Figure
A36315903, A34315903	(all)	50/60	<i>Figure: Three-phase motors: 200-220 V 50 Hz and 200-230 V 60 Hz on page 28</i>
A34315981, A36315981	115	60	<i>Figure: Single-phase motors: 100 V 50 Hz, 100-105 V 60 Hz and 115 V 60 Hz on page 24</i>
	230	60	<i>Figure: Single-phase motors: 200 V 50 Hz, 200-210 V 60 Hz and 230 V 60 Hz on page 25</i>
A34315904, A36315904	100 100 - 105	50 60	<i>Figure: Single-phase motors: 100 V 50 Hz, 100-105 V 60 Hz and 115 V 60 Hz on page 24</i>
	200 200 - 210	50 60	<i>Figure: Single-phase motors: 200 V 50 Hz, 200-210 V 60 Hz and 230 V 60 Hz on page 25</i>
A34316903	(all)	50/60	<i>Figure: Single-phase motors with Amphenol connector: 220-240 V 50 Hz and 230-240 V 60 Hz on page 25</i>
A34317984, A36317984, A34317984, A36317984	(all)	50/60	<i>Figure: Motor voltage selection: single-phase motors, 110/200-240 V 50 Hz and 115-120/200-240 V 60 Hz on page 26</i>

4.6.1 Standard single-phase motors

1. Remove the cover from the motor terminal box (*Figure: General view of the pump on page 11*).
2. Remove the cable-gland from the inside of the terminal-box and fit the cable-gland to the cable lead-through hole in the side of the terminal-box. Using a tool this should be tightened to a torque of 3.75 Nm.
3. Pass the electrical supply cable through the gland.
4. Remove the receptacle connectors from the fitting pack.
5. Fit a ring connector to the earth (ground) wire.
6. Select the correct size of receptacle connectors for the cable wires:
 - Use the red connectors for wire sizes 0.75 mm² to 1.5 mm².
 - Use the blue connectors for wire sizes 1.5 mm² to 2.5 mm².
7. Attach the appropriate connector to the live and neutral wires.
8. Connect the electrical supply cable to the appropriate terminals as shown in:
 - *Figure: Three-phase motors: 200-220 V 50 Hz and 200-230 V 60 Hz on page 28*

- [Figure: Single-phase motors: 100 V 50 Hz, 100-105 V 60 Hz and 115 V 60 Hz on page 24](#)
 - [Figure: Single-phase motors: 200 V 50 Hz, 200-210 V 60 Hz and 230 V 60 Hz on page 25.](#)
9. Tighten the earth (ground) terminal connection to a torque of 2.13 Nm to 2.8 Nm.
 10. Tighten the dome shaped nut on the cable-gland until the outer sheath of the cable is firmly gripped. Using a tool this should be tightened to a torque of 2.5 Nm, do not overtighten.
 11. Check that the cable connections are correct, then refit the cover on the motor terminal-box.

4.6.2 Amphenol version single-phase motors

When selecting the mating half of the amphenol connector, please ensure that it is compatible.

The protective earth (ground) connection is required to make first and break last with respect to the other connections.

Connect the electrical supply cable to the appropriate pins as shown in [Figure: Single-phase motors with Amphenol connector: 220-240 V 50 Hz and 230-240 V 60 Hz on page 25.](#)

4.6.3 110/200-240 V 50 Hz or 115-120/200-230 V 60 Hz single-phase motors

The motor is designed for a single-phase electrical supply and is suitable for 50 Hz and 60 Hz operation. The motor can be manually switched between nominal supply voltages of 110-120 V and 200-240 V.

Use the following procedure to check that the voltage selector switch is correctly positioned for the electrical supply voltage:

1. Refer to [Figure: Motor voltage selection: single-phase motors, 110/200-240 V 50 Hz and 115-120/200-240 V 60 Hz on page 26.](#) Undo the three screws securing the terminal box cover and remove the cover.
2. Check the position of the voltage selector switch. If the switch is in the correct position, continue at step 3. If the voltage selector switch is in the wrong position, press the switch to select the alternative position.
3. Refit the terminal box cover and secure with the three screws.

When selecting the mating half of the connector, please ensure that it is compatible (IEC60320 C19 female).

Figure 4 Single-phase motors: 220-240 V 50 Hz and 230-240 V 60 Hz

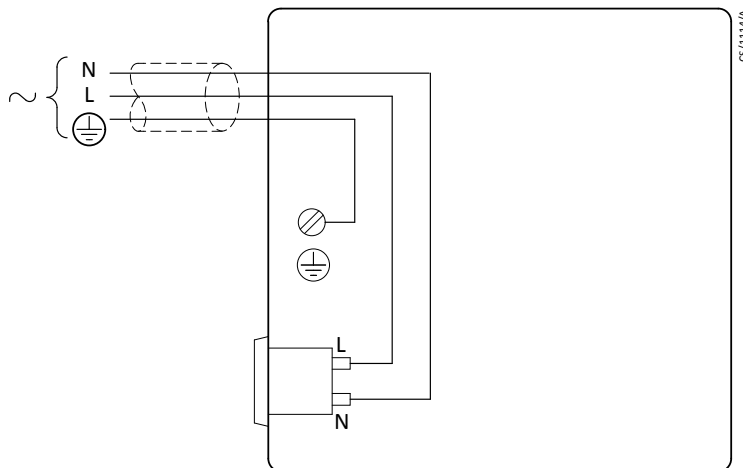
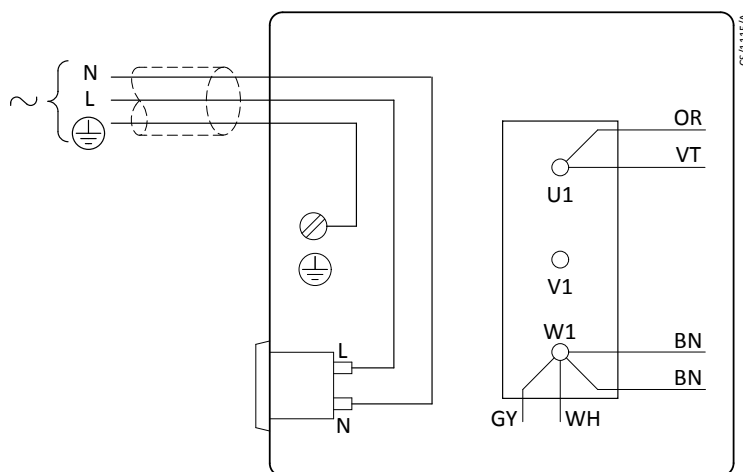
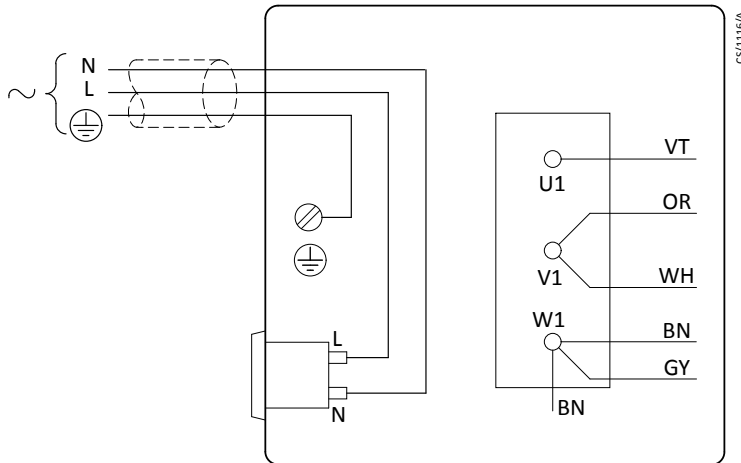

Figure 5 Single-phase motors: 100 V 50 Hz, 100-105 V 60 Hz and 115 V 60 Hz



Wire colour codes:			
BN	Brown	VT	Violet
GY	Grey	WH	White
OR	Orange		

Figure 6 Single-phase motors: 200 V 50 Hz, 200-210 V 60 Hz and 230 V 60 Hz



Wire colour codes:			
BN	Brown	VT	Violet
GY	Grey	WH	White
OR	Orange		

Figure 7 Single-phase motors with Amphenol connector: 220-240 V 50 Hz and 230-240 V 60 Hz

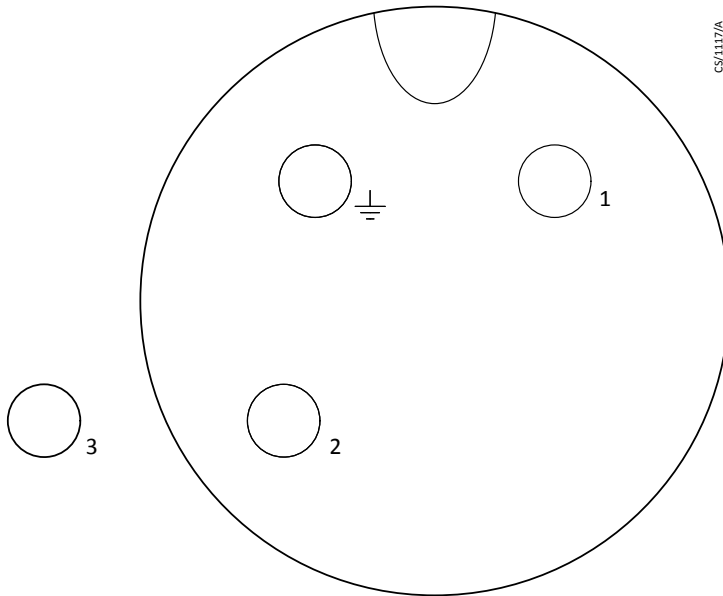

Pin codes:	
1	Live
2	Neutral
3	Not used
	Earth (ground)

Figure 8 Motor voltage selection: single-phase motors, 110/200-240 V 50 Hz and 115-120/200-240 V 60 Hz

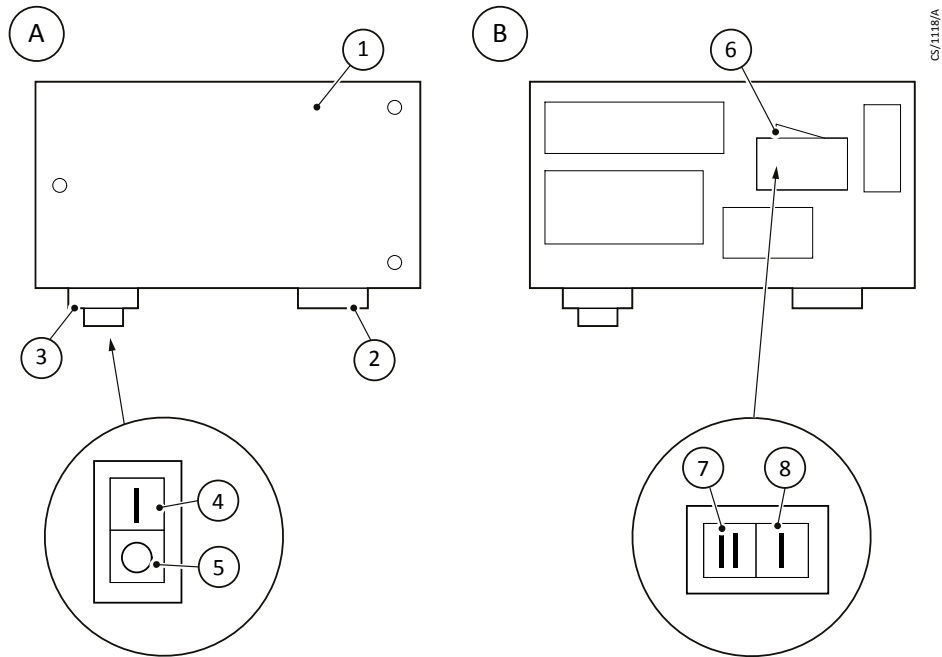

A. Top view of motor
C. On/Off switch

- 1. Terminal box cover
- 3. On/Off switch
- 5. Position 'O' (off)
- 7. Position 'II' (high voltage setting 200-240 V)

B. Internal view of top of motor

- 2. Electrical inlet socket
- 4. Position 'I' (on)
- 6. Voltage selector switch
- 8. Position 'I' (low voltage setting 110-120 V)

4.7 Electrical installation: three-phase motors

4.7.1 Connect the electrical supply to the motor



WARNING:

Ensure that the electrical installation of your pump-motor conforms with your local and national safety requirements. It must be connected to a suitably fused and protected electrical supply and a suitable earth point.



CAUTION:

If your pump-motor can be used with more than one voltage range, you must ensure that the motor is configured for your electrical supply voltage. If you do not, you may damage the motor.

Note:

The pump will restart automatically when the electrical supply is restored after an interruption. If you do not want the pump to restart automatically, use electrical control equipment which must be reset manually.

We recommend that you connect the electrical supply to the motor through a starter or circuit breaker which has thermal over-current protection which can be adjusted to suit the full load current ratings shown in [Table: Electrical data: three-phase motors on page 17](#). The fuse ratings in [Table: Electrical data: three-phase motors on page 17](#) are provided for guidance only. The supplier of the thermal over-current protection device may specify different values to ensure correct operation of the fuse and the over-current protection device. Ensure that the fuse used is suitable for the starting currents given in [Table: Electrical data: three-phase motors on page 17](#).

Refer to [Figure: Three-phase motors: 200-220 V 50 Hz and 200-230 V 60 Hz on page 28](#) or [Figure: Three-phase motors: 380-415 V 50 Hz and 460 V 60 Hz on page 29](#) as appropriate for the correct electrical supply connection diagram for the motor.

The diameter of the outer sheath of the electrical cable must be in the range 10-14 mm. The cable must conform in size and colour coding with the local and national electrical installation regulations. The temperature rating of the cable must be 70 °C or greater.

1. Remove the cover from the motor terminal-box.
2. Remove the cable-gland from the inside of the terminal-box and fit the cable-gland to the cable lead-through hole in the side of the terminal-box. Using a tool this should be tightened to a torque of 3.75 Nm.
3. Refer to the electrical supply connection diagram for the pump. Make sure that the metal links are connected as shown; if they are not, move the links to the positions shown.
4. Pass the electrical supply cable through the cable-gland and connect to the appropriate terminals. Tighten the earth (ground) terminal connection to a torque of 2.13 to 2.87 Nm.
5. Tighten the dome shaped nut on the cable gland until the outer sheath of the cable is firmly gripped. Using a tool this should be tightened to a torque of 2.5 Nm, do not overtighten.
6. Ensure that the gasket seal for the terminal box cover is correctly positioned, then refit the cover to the terminal-box and secure with the screws.

4.7.2 Check the direction of rotation



CAUTION:

Ensure that the pump-motor rotates in the correct direction. If it does not, the pump and your vacuum system can become pressurised.

1. With the pump inlet still unconnected, watch the motor cooling-fan through the motor fan-cover.
2. Switch-on the electrical supply to the motor for a few seconds and switch off.
3. Check that the motor cooling-fan rotates in the direction shown by the arrow on the motor mounting-plate. If the direction of rotation is incorrect:
 - Isolate the pump from the electrical supply
 - Remove the terminal-box cover and swap wires L1 and L3. Refer to the wiring diagram supplied in the motor terminal box
 - Refit the cover to the terminal-box
 - Connect the pump to the electrical supply

- Check the direction of rotation again.

4.8 Connect the pump inlet

Take note of the following information when connecting the pump to the vacuum system. Refer to [Accessories on page 46](#) for details of the accessories mentioned below.

- For optimum pumping speeds, ensure that the pipeline connected to the inlet-port is as short as possible and has an internal diameter not less than the inlet-port diameter.
- Support the vacuum pipelines to prevent loading of the coupling-joints.
- If necessary, incorporate flexible bellows in the system pipelines to reduce the transmission of vibration and to prevent loading of coupling-joints. If you are using flexible bellows, ensure that bellows are used which have a maximum pressure rating which is greater than the highest pressure that can be generated in the system. It is recommended that manufacturers flexible bellows are used.
- Use a suitable inlet catchpot if pumping condensable vapours or if using the pump for very dusty applications.
- Ensure that sealing surfaces are clean and scratch-free.

Connect the vacuum system to the inlet-port ([Figure: General view of the pump on page 11](#)). To make this connection:

- Connect to the NW25 flange supplied: use the NW25 centring-ring and O-ring supplied.
- Remove the NW25 flange and connect to the 1 inch BSP threaded hole.
- Use an NW25 to 28 mm bore tube adaptor available as an optional accessory, refer to [Pump inlet adaptor on page 48](#).

Figure 9 Electrical supply connection, three-phase motors: 200-220 V 50 Hz and 200-230 V 60 Hz

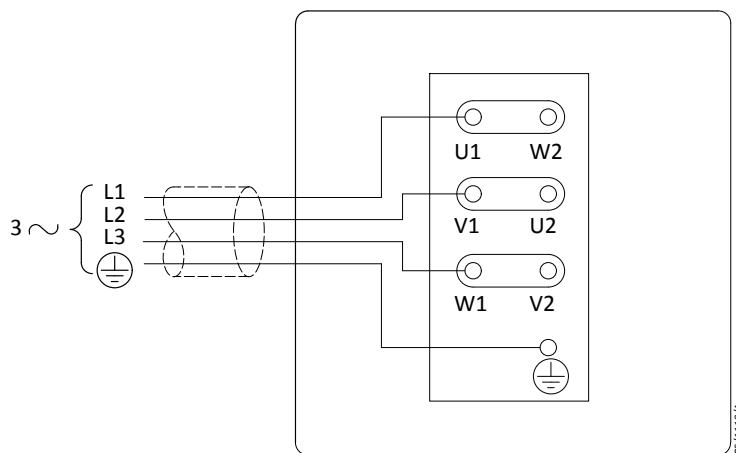
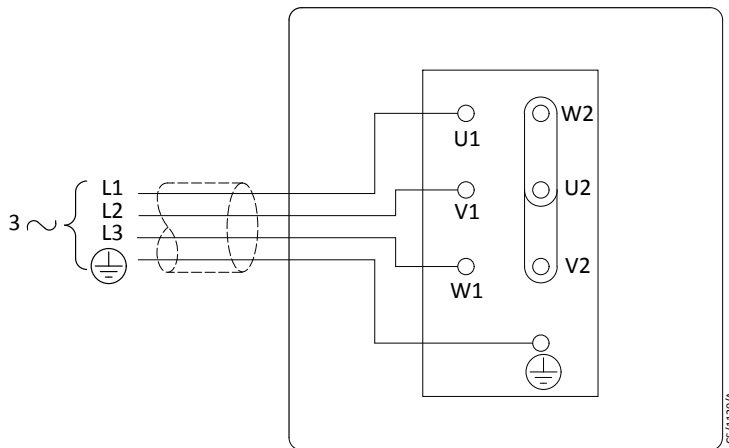

Figure 10 Electrical supply connection, three-phase motors: 380-415 V 50 Hz and 460 V 60 Hz

4.9 Connect the pump outlet



WARNING:

Connect the pump outlet to a suitable treatment plant to prevent the discharge of dangerous gases and vapours to the surrounding atmosphere. Use a catchpot to prevent the drainage of contaminated condensate back into the pump.

The exhaust system must be configured so that the maximum pressure at the pump outlet does not exceed 0.5 bar gauge (1.5 bar absolute, 1.5×10^5 Pa) at full pump throughput.

We recommend fitting an oil mist filter to the pump outlet in the following circumstances:

- When using the pump with the gas-ballast control open.
- When operating the pump with an inlet pressure greater than 10 mbar for extended periods.
- When frequently pumping down from atmospheric pressure.

The mist filter will trap the oil exhausted from the pump: the oil can be reused if it is not contaminated.

To connect the pump to the outlet accessories or to the exhaust treatment plant:

- Connect 15 mm internal diameter vacuum or plastic hose to the outlet nozzle (*Figure: General view of the pump on page 11*).
- Remove the outlet nozzle and connect to the 3/4 inch BSP threaded hole.
- Remove the outlet nozzle and replace it with an NW25 flange adaptor (available as an optional accessory, refer to *Pump outlet adaptor on page 48*) and then connect to the NW25 flange.

4.10 Gas-ballast inlet connection

The position of the gas-ballast inlet is shown in *Figure: General view of the pump on page 11*. The gas-ballast inlet has several filters (shown in *Figure: Remove/replace the*

[gas-ballast filter on page 40](#)) to trap any dust and debris if air is used as the gas-ballast supply.

If using a different gas for the gas-ballast supply or to connect a valve to the gas-ballast inlet:

1. Remove the filters (as described in [Clean the gas-ballast filter on page 39](#)).
2. Connect the gas supply or valve to the 1/4 inch BSP threaded hole.

4.11 Leak-test the system

Leak-test the system and seal any leaks found after you have installed the pump, to prevent leakage of substances out of the system and leakage of air into the system.

5. Operation



WARNING:

Do not expose any part of the human body to vacuum. Failure to obey this warning could result in injury.

Note:

If the pump is PFPE-prepared, refer to [PFPE-prepared EM pumps on page 49](#).

5.1 ATEX directive implications

This equipment is designed to meet the requirements of Group II Category 3 equipment in accordance with Directive 2014/34/EU of the European Parliament and the Council of 26th February 2014 on the approximation of the laws of the Member States concerning equipment and protective systems intended for use in potentially explosive atmospheres. (The ATEX Directive)

The ATEX Category 3 applies in respect of potential ignition sources internal to the equipment. An ATEX Category has not been assigned in respect of potential ignition sources on the outside of the equipment as the equipment has not been designed for use where there is an external potentially explosive atmosphere.

There is no potential source of ignition within the pump during normal operation but there may be potential sources of ignition under conditions of predictable and rare malfunction as defined in the Directive. Accordingly, although the pump is designed to pump flammable materials and mixtures, operating procedures should ensure that under all normal and reasonably predictable conditions, these materials and mixtures are not within explosive limits. Category 3 is considered appropriate for the avoidance of ignition in the case of a rare malfunction which allows flammable materials or mixtures to pass through the pump whilst within their explosive limits.

5.1.1 Flammable/pyrophoric materials



WARNING:

Obey the instructions and take note of the precautions given below to ensure that pumped gases do not enter their flammable ranges

When flammable or pyrophoric materials are present within the equipment:

- Do not allow air to enter the equipment.
- Ensure that the system is leak tight.
- Use an inert gas purge (for example, a nitrogen purge) to dilute any flammable gases or vapours entering the pump inlet, and/or use an inert gas purge to reduce the concentration of flammable gases or vapours in the pump and in the exhaust pipeline to less than one quarter of the gases' published Lower Explosive Limits (LEL).

- Use an inert gas purge into the pump gas ballast connection to prevent the condensation of flammable vapours within the pump mechanism and exhaust pipeline.

5.1.2 Gas purges



WARNING:

If using inert gas purges to dilute dangerous gases to a safe level, ensure that the pump is shut down if an inert gas supply fails.



WARNING:

Obey the instructions and take note of the precautions given below to ensure that pumped gases do not enter their flammable ranges.

Switch on the inert gas purge to remove air from the pump and the exhaust pipeline before the process starts. Switch off the purge flow at the end of the process only after any remaining flammable gases or vapours have been purged from the pump and exhaust pipeline.

If liquids that produce flammable vapours could be present in the pump foreline, then the inert gas purge to the pump should be left on all the time this liquid is present. Flammable liquids could be present in the foreline as a result of condensation or may be carried over from the process.

When calculating the flow rate of inert gas required for dilution, consider the maximum flow rate for the flammable gases/vapours that could occur. For example, if a mass flow controller is used to supply flammable gases to the process, assume a flow rate for flammable gases that could arise if the mass flow controller is fully open.

Continually measure the inert gas purge flow rate: if the flow rate falls below that required, stop the flow of flammable gases or vapours into the pump.

Note:

We recommend obtaining and reading the Vacuum Pump and Vacuum System Safety manual (publication number P40040100), available from us or the supplier.

5.2 Gas-ballast control

Use the gas-ballast control ([Figure: General view of the pump on page 11](#)) to change the flow of gas-ballast into the low vacuum stage of the pump and to provide an additional oil-feed to the pump mechanism.

Use the gas-ballast control closed:

- To achieve ultimate vacuum.
- To pump dry gases.

Turn the gas-ballast control by up to two turns anti-clockwise to introduce an additional oil-feed to the pump mechanism. We recommend doing this when pumping high throughputs of dry gases.

Turn the gas-ballast control from two to six turns anti-clockwise to increase the gas-ballast from zero flow. Use gas-ballast flow:

- To pump high concentrations of condensable vapour.
- To decontaminate the oil.

When operating the pump with the gas-ballast control open there will be an increased rate of oil loss from the pump. Ideally, a mist filter and oil return kit should be used on clean applications.

5.3 Start-up



WARNING:

Do not block the pump outlet or allow the outlet pressure to rise above 1.5 bar absolute. The oil box may fracture and may cause injury to people nearby.

If the oil is contaminated, or if the pump temperature is below 13 °C, or if the electrical supply voltage is more than 10% below the lowest voltage specified for the pump, the pump may operate at a reduced speed for a few minutes. On single-phase pumps, if the pump continues to operate at reduced speed, the motor thermal overload device will open and stop the pump. When the motor has cooled, the thermal overload device will reset automatically and the pump will restart.

1. Check that the pump oil-level is between the MAX and MIN marks on the bezel of the oil-level sight-glass; if it is not, refer to [Check the oil level on page 37](#).
2. Turn the gas-ballast control to the required position (refer to [Gas-ballast control on page 32](#)).
3. Switch on the electrical supply to the pump.
4. Check that the oil-level in the sight-glass drops slightly (by 3 to 5 mm) after start-up. This shows that the pump has primed with oil.
5. If the pump fails to prime, operate the pump with the inlet open to atmosphere for approximately 30 seconds. Then isolate the inlet and check that the oil-level drops by 3 to 5 mm.
6. To achieve ultimate vacuum, pump condensable vapours or decontaminate the pump oil, refer to the procedures in [To achieve ultimate vacuum on page 33](#), [To pump condensable vapours on page 34](#) and [To decontaminate the oil on page 34](#) respectively. Otherwise, open the vacuum system isolation-valve.

5.4 To achieve ultimate vacuum

If the pump does not achieve the performance specified in Performance, make sure that this is not due to the system design before you contact supplier or us for advice, In particular, the vapour pressure of all materials used in the vacuum system (including pump oil) must be much lower than the specified ultimate vacuum of the pump.

Refer to [The pump fails to achieve specified performance \(failure to reach ultimate vacuum\) on page 41](#) for a list of possible causes for failure to achieve the specified performance, note however that the most common causes are:

- Pressure measurement technique or gauge head is unsuitable or the gauge head is faulty.

- Use of an oil other than the recommended oil and the vapour pressure of the oil is higher than the specified ultimate vacuum of the pump.

Use the following procedure to achieve ultimate vacuum:

1. Isolate the pump from the vacuum system.
2. Turn the gas-ballast control fully anti-clockwise (fully open) and operate the pump for at least 1 hour (or overnight) to thoroughly purge the oil of contaminants.
3. Close the gas-ballast control.
4. Open the vacuum system isolation-valve and pump down to ultimate vacuum.

5.5 To pump condensable vapours

Use gas-ballast (open the gas-ballast control) when there is a high proportion of condensable vapours in the process gases:

1. Close the vacuum system isolation-valve.
2. Turn the gas-ballast control anti-clockwise to fully open and operate the pump for 30 minutes to warm the oil, this will help to prevent vapour condensation in the pump.
3. Open the vacuum system isolation-valve and continue to operate the pump with the gas-ballast control open.

After pumping condensable vapours, decontaminate the oil (if necessary), use the procedure in [To decontaminate the oil on page 34](#).

5.6 To decontaminate the oil

The oil in the pump should be clear. If the oil is cloudy or discoloured, it is contaminated with process vapours.

1. Look at the condition of the oil in the oil sight-glass ([Figure: General view of the pump on page 11](#)). If the oil is cloudy or discoloured, continue with the procedure at step 2 below.
2. Close the vacuum system isolation-valve.
3. Turn the gas-ballast control fully anti-clockwise.
4. Operate the pump until the oil is clear.

5.7 Unattended operation

The pump is designed for unattended operation under the normal operating conditions specified in [Operating and storage conditions on page 13](#). However, we recommend checking the pump at a regular interval of not more than 14 days; check the pump more frequently if pumping high volumes of gas or if operating the pump with the gas-ballast control open.

Single-phase motors are cooled by internal fans. These motors have a thermal overload device. When the motor is too hot, the thermal overload device switches off the pump. The thermal overload device has an automatic reset; when the motor cools down, the device resets and the motor will restart.

When checking the pump, make sure that the pump is not going through a repetitive cycle of thermal overload failures and automatic resets. If necessary, reduce the thermal load from the pumped gases to prevent overheating of the pump.

5.8 Shut-down

 **Note:**

If the gas-ballast control is open and the motor is switched off for any reason, the pump drive shaft may rotate in the reverse direction, causing a system pressure rise. To prevent this, use a gas-ballast control valve (refer to [Gas ballast valve on page 48](#)).

We recommend, as described in the procedure below, decontaminating the oil before shutting down the pump; this will prevent damage to the pump by the contaminants in the oil.

1. Refer to [To decontaminate the oil on page 34](#) and decontaminate the oil, as required.
2. Close the vacuum system isolation-valve (if not already closed).
3. Close gas-ballast (that is, turn the gas-ballast control clockwise).
4. Switch off the electrical supply to the pump.

6. Maintenance

6.1 Safety information



WARNING:

Allow the pump to cool (so that it is at a safe temperature for skin contact) before starting maintenance work. Make sure the pump is switched off in case the thermal overload device restarts the pump.



WARNING:

Obey the safety instructions given below and take note of appropriate precautions. Failure to do so can cause injury to people and damage to equipment.



CAUTION:

Never use hydrocarbon lubricants in a PFPE-prepared pump.

 **Note:**

If the pump is PFPE-prepared, refer to [PFPE-prepared EM pumps on page 49](#).

- A suitably trained and supervised technician must maintain the pump.
- Ensure that the maintenance technician is familiar with the safety procedures which relate to the pump-oil and the products processed by the pumping-system.
- Isolate the pump and other components in the pumping system from the electrical supply so that they cannot be operated accidentally.
- After maintenance is completed, recheck the pump rotation direction if the electrical supply has been disconnected.
- Do not reuse O-rings and seals if they are damaged.
- The pump and its oil will be contaminated with the process chemicals that have been pumped during operation. Ensure that the pump is decontaminated before maintenance and that adequate precautions are taken to protect people from the effects of dangerous substances if contamination has occurred.
- Leak-test the system after maintenance work is complete if connecting or disconnecting any vacuum or exhaust joints; seal any leaks found.
- Do not touch or inhale the thermal breakdown products of fluorinated materials which may be present if the pump has been heated to 260 °C and above. These breakdown products are very dangerous. Fluorinated materials in the pump may include oils, greases and seals. The pump may have overheated if it was misused, if it malfunctioned or if it was in a fire. Manufacturers Material Safety Data sheets for fluorinated materials used in the pump are available on request: contact supplier or us.

6.2 Maintenance plan

The plan shown in [Table: Maintenance plan on page 37](#) details the routine maintenance operations necessary to maintain the pump in normal use. Instructions for each operation are given in the section shown.

More frequent maintenance may be required if the pump is used to process corrosive or abrasive gases and vapours, in these circumstances, we recommend you to replace the pump seals every year. If necessary, adjust the maintenance plan according to experience.

When carrying out maintenance on the pump, use our spares and maintenance kits, these contain all the components necessary to complete maintenance operations successfully. The item numbers of the spares and kits are given in Spares.

Examine the condition of any external accessory, filters or traps (if fitted) when carrying out maintenance on the pump. Refer to the instructions supplied with these accessories for the necessary maintenance procedures.

Maintenance plan

Operation	Frequency	Refer to section
Check the oil level	As required; at least monthly	Check the oil level on page 37
Replace the oil	Every 3000 hours of operation	Replace the oil on page 38
Inspect and clean the inlet filter	Every oil change	Inspect and clean the inlet-filter on page 38
Clean or replace the gas-ballast filter	Yearly	Clean the gas-ballast filter on page 39
Clean the motor fan-cover and enclosure	Yearly	Clean the motor fan-cover and enclosure on page 40
Clean and overhaul the pump	Every 15000 hours of operation	Clean and overhaul the pump on page 40
Replace the run capacitor	Every 4 years	Replace the run capacitor and test the motor on page 40
Test the motor condition	Every 15000 hours of operation	Replace the run capacitor and test the motor on page 40
Fit new blades	Every 30000 hours of operation	Fit new blades on page 40

6.3 Check the oil level

Note:

1. If required, it is possible to check the oil-level while the pump is operating, however the pump must be switched off. Isolate the pump and other components in the pumping system from the electrical supply before pouring oil into the pump.

2. Do not mix hydrocarbon lubricants with PFPE or vice versa. If the oil is mixed, drain and refill with clean oil as described in [Replace the oil on page 38](#).

Refer to [Figure: General view of the pump on page 11](#) for the items in brackets.

1. Check that the oil-level in the oil sight-glass is between the MAX and MIN level marks on the bezel of the oil sight-glass.
2. If the oil-level is near to or below the MIN level mark, remove the oil filler-plug and pour more oil into the reservoir until the oil reaches the MAX level mark. If the oil-level goes above the MAX mark, remove the oil drain-plug and drain the excess oil from the pump. Refit the oil drain-plug. Refit the oil filler-plug.
3. If the oil is contaminated, drain and refill the pump with clean oil as described in [Replace the oil on page 38](#).

6.4 Replace the oil

Refer to [Figure: General view of the pump on page 11](#) for the items in brackets.

1. Operate the pump for approximately ten minutes to warm the oil, then switch off the pump. (This lowers the viscosity of the oil and allows the oil to be drained from the pump more easily).
2. Isolate the pump from the electrical supply and disconnect it from the vacuum system.
3. Remove the oil filler-plug.
4. Place a suitable block under the pump-motor to tilt the pump and place a suitable container under the oil drain-plug (gravity drain). Remove the oil drain-plug and allow the oil to drain into the container.
5. If the oil is dirty or contaminated:
 - Refit the oil drain-plug and pour clean oil into the pump.
 - Reconnect the pump to the electrical supply and operate the pump for about 5 to 10 minutes.
 - Disconnect the pump from the electrical supply, remove the oil drain-plug and allow the oil to drain out of the pump.
 - Repeat this step until the oil reservoir is clean.
6. Refit the oil drain-plug, remove the block and reconnect the pump to the vacuum system.
7. Fill a suitable container with clean oil and pour the oil into the filler hole until the oil-level reaches the MAX level mark on the bezel of the oil sight-glass.
8. Allow a few minutes for the oil to drain into the pump. If necessary, add more oil. Refit the oil filler-plug.

6.5 Inspect and clean the inlet-filter

Refer to [Figure: Remove/replace the inlet filter on page 39](#).

1. Unscrew the inlet adaptor and remove the O-ring, circlip and inlet-filter.
2. Wash the filter in a suitable cleaning solution. Allow the filter to dry.
3. Refit the inlet-filter, circlip, O-ring and inlet adaptor.

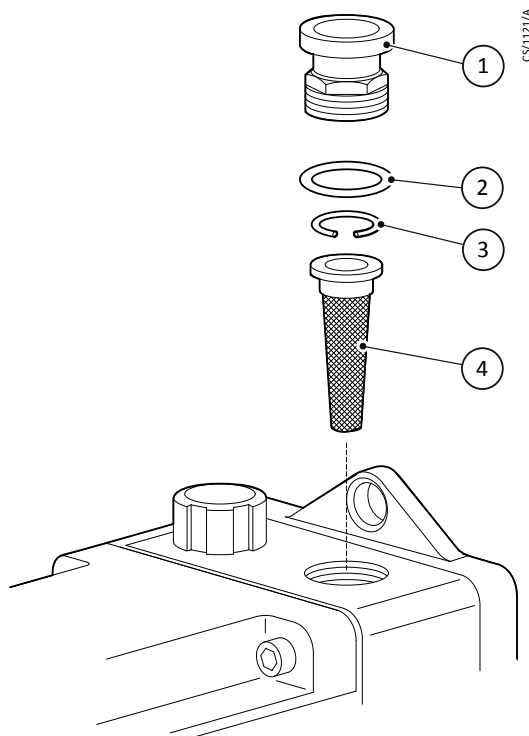
Figure 11 Remove/replace the inlet filter

1. Inlet adaptor
3. Circlip

2. O-ring
4. Inlet-filter

6.6 Clean the gas-ballast filter

Note:

The gas-ballast filter may have been removed to connect a gas supply or valve to the gas-ballast inlet.

Refer to [Figure: Remove/replace the gas-ballast filter on page 40](#).

1. Remove the retainer circlip.
2. Remove the protective wire mesh and filter elements.
3. Wash the wire mesh and filter in a suitable cleaning solution. Allow the wire mesh and filter to dry before replacing them in the pump.
4. Refit the wire mesh and filter element in the adaptor plate housing and retain with the retainer circlip.

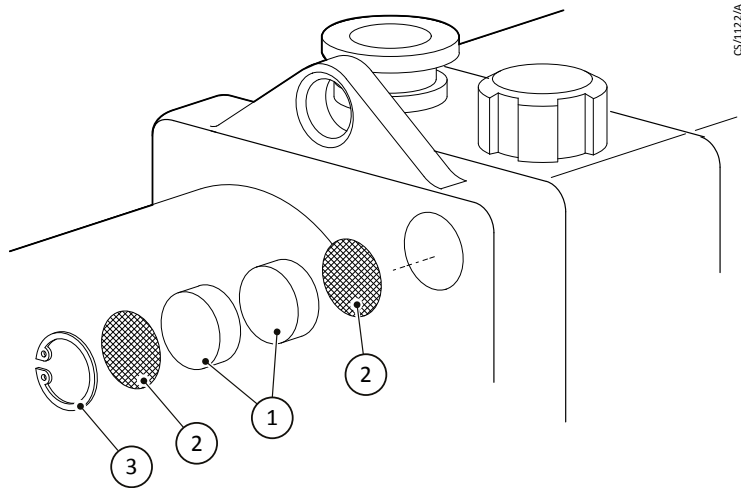
Figure 12 Remove/replace the gas-ballast filter

1. Filter element
3. Retainer circlip

2. Wire mesh

6.7 Clean the motor fan-cover and enclosure

If the motor fan-cover and enclosure are not kept clean, the air flow over the motor can be restricted and the pump may overheat.

1. Switch off the pump and disconnect it from the electrical supply.
2. Use a dry cloth and a brush to remove dirt and deposits from the fan-cover and enclosure.

6.8 Clean and overhaul the pump

Clean and overhaul the pump as described in the instructions supplied with the clean and overhaul kit (see [Spares and accessories on page 45](#)).

6.9 Replace the run capacitor and test the motor

Replace the run capacitor as described in the instructions supplied with the capacitor kit.

Test the earth (ground) continuity and the insulation resistance of the pump-motor, in accordance with local regulations for periodic testing of electrical equipment. We recommend that:

- The earth (ground) continuity is less than 0.1 Ω .
- Insulation resistance is greater than 10 M Ω .

If the motor fails these tests, the motor must be replaced.

6.10 Fit new blades

Fit new blades to the pump as described in the instructions supplied with the blade kit (see [Spares and accessories on page 45](#)).

7. Fault finding

A list of fault conditions and their possible causes is provided in the following sections to assist in basic fault-finding. If unable to rectify a fault when using this guide, call the supplier or our nearest service centre for advice.

7.1 The pump has failed to start

- The electrical supply fuse has failed.
- The motor is incorrectly wired.
- The operating voltage does not match that of the motor.
- The exhaust filter or exhaust line is blocked.
- The oil temperature is below 13 °C.
- The oil is too viscous.
- The oil is contaminated.
- The pump is seized after long storage or has been left to stand after pumping contaminants.
- The motor is faulty.

7.2 The pump fails to achieve specified performance (failure to reach ultimate vacuum)

- The measuring technique or gauge is unsuitable.
- There is a leak in the external vacuum system.
- The gas-ballast control is open.
- The oil level is too low.
- The pump has been filled with the wrong type of oil.
- The oil is contaminated.
- The pump has not primed.
- The vacuum fittings are dirty.
- The inlet-filter is blocked.
- The pump has not warmed up.
- The motor shaft rotates in the wrong direction.

7.3 The pump is noisy

- The motor fan-cover is damaged.
- The coupling and fan assembly are poorly adjusted.
- The motor coupling is loose.
- The motor bearings are worn.
- The oil is contaminated with solid particles.
- One of the pump blades is sticking.

7.4 The pump surface temperature is above 100 °C

- The ambient temperature is too high.
- The cooling-air supply is insufficient or is too hot.
- The cooling-air supply is blocked.
- The electrical supply voltage is too high.
- The exhaust filter or exhaust line is blocked.
- The oil level is too low.
- The pump is filled with the wrong type of oil.
- The oil is contaminated.
- The process gas is too hot or the throughput is too high.

7.5 The vacuum is not maintained after the pump is switched off

- The gas-ballast control is open.
- O-ring(s) are damaged or missing.
- The shaft seals have deteriorated.

7.6 The pumping speed is poor

- The connecting pipelines are too small in diameter.
- The connecting pipelines are too long.
- The inlet-filter is blocked.

7.7 There is an external oil leak

- The oil pump shaft seal is worn or damaged.
- The oil box gasket has deteriorated.
- There is an oil leak from gas-ballast control.
- There is an oil-leak from the drain-plug.

8. Storage



CAUTION:

Observe the storage temperature limits stated in [Technical data on page 13](#). Storage below - 30 °C will permanently damage the pump seals.

Note:

If you will store a new pump in conditions of high humidity, remove the pump from its cardboard packaging box, dispose of the box (refer to [Disposal on page 44](#)).

Use the following procedure to store the pump:

1. Ensure that the pump has been shut-down as described in Operation.
2. Isolate the pump from the electrical supply.
3. Purge your vacuum system and the pump with dry nitrogen and disconnect the pump from your vacuum system.
4. Replace the oil as described in [Replace the oil on page 38](#).
5. Place and secure protective covers over the inlet and outlet-ports.
6. Store the pump in cool, dry conditions until required for use.
7. When required, prepare and install the pump as described in Installation. If the pump has been stored for more than a year, before you install the pump you must clean and overhaul it as described in the instruction supplied with the clean and overhaul kit.

9. Disposal

Dispose of the pump, the oil and any components removed from the pump safely in accordance with all local and national safety and environmental requirements.

Particular care must be taken with components and waste oil which have been contaminated with dangerous process substances.

Do not incinerate fluoroelastomer seals and O-rings.

10. Spares and accessories

Our products, spares and accessories are available from our companies in Belgium, Brazil, China, France, Germany, Israel, Italy, Japan, Korea, Singapore, United Kingdom, U.S.A and a world-wide network of distributors. The majority of these centres employ service engineers who have undergone comprehensive our training courses.

Order spare parts and accessories from our nearest company or distributor. When ordering, state for each part required:

- Model and item number of the equipment
- Serial number
- Item number and description of part.

10.1 Spares

The maintenance kits listed in [Table: Spares item numbers on page 45](#) contains all the parts required to maintain the pump. The maintenance kits also include instructions for the use of the kits.

Use the clean and overhaul kit for routine maintenance operations. Use the blade kit together with the clean and overhaul kit when renewing the blade assembly in the rotary pump.

Table 11 Spares item numbers

Spare	Item Number
Clean and Overhaul kit (Hydrocarbon filled)	A36301131
Clean and Overhaul kit (PFPE filled)	A36301136
E1M18 Blade kit	A34301041
E2M18 Blade kit	A36301020
Ultragrade 19 Oil (4 litres)	H11025013
Fomblin Grade 06/6-500 ml	H11301016
Capacitor kit for pump part number A34315903	A50591813
Capacitor kit for pump part number A34316903	A50591813
Capacitor kit for pump part number A36315903	A50591813
Capacitor kit for pump part number A34315904	A50591800
Capacitor kit for pump part number A36315904	A50591800
Capacitor kit for pump part number A36325904	A50591800
Capacitor kit for pump part number A34315912	A50591811
Capacitor kit for pump part number A36315912	A50591811
Capacitor kit for pump part number A36325912	A50591811
Capacitor kit for pump part number A34315920	A50591812
Capacitor kit for pump part number A36315920	A50591812
Capacitor kit for pump part number A34315981	A50591800
Capacitor kit for pump part number A36315981	A50591800

Spare	Item Number
Capacitor kit for pump part number A34317984	A50591814
Capacitor kit for pump part number A34325984	A50591814
Capacitor kit for pump part number A36317984	A50591814
Capacitor kit for pump part number A36325984	A50591814

10.2 Accessories

A range of accessories is available for the pumps, as shown in [Figure: Accessories on page 46](#).

The accessories are briefly described in the following sections. Refer to [Table: Accessory item numbers on page 47](#) for the item numbers of these accessories.

Figure 13 Accessories

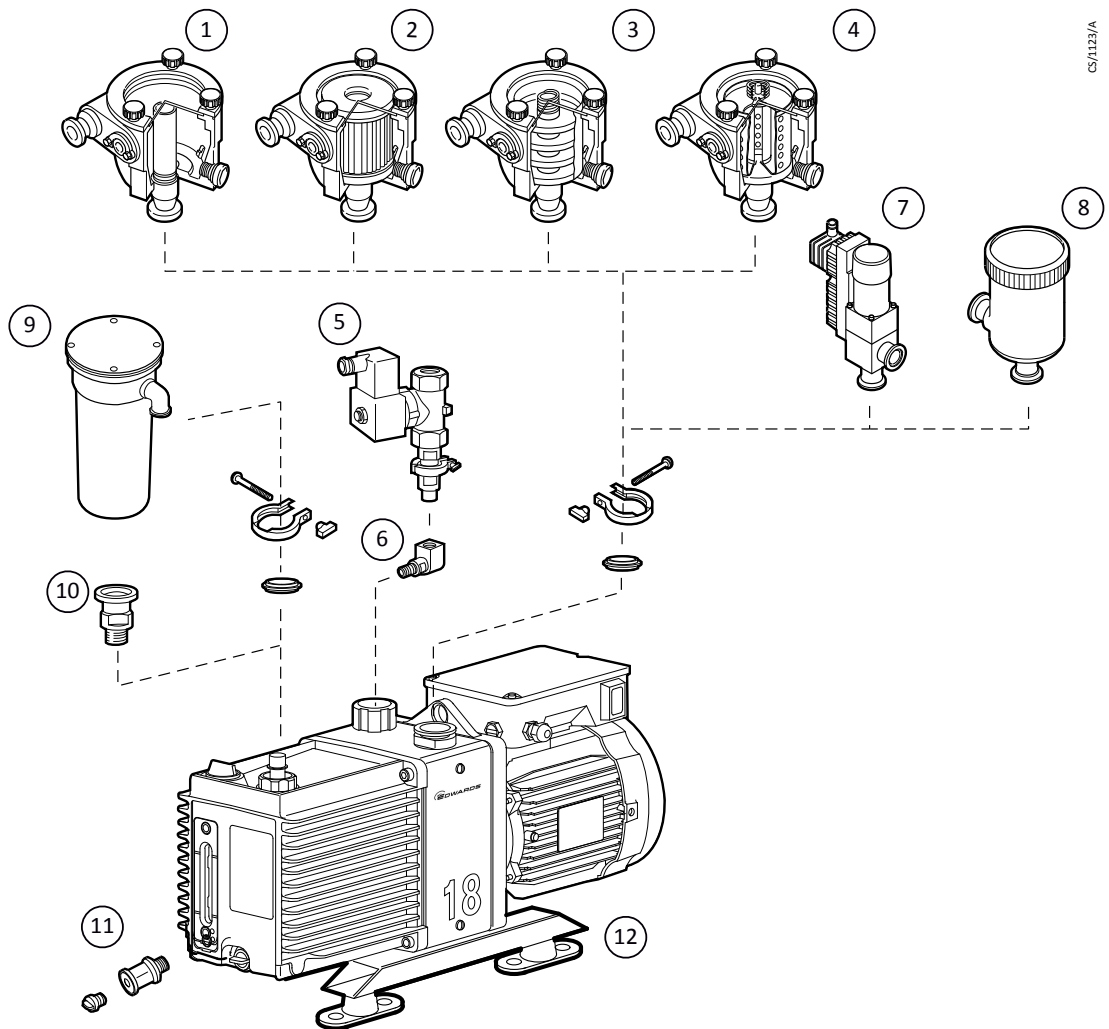

- | | |
|-------------------------------------|-------------------------|
| 1. Inlet catchpot | 2. Inlet dust filter |
| 3. Inlet desiccant trap | 4. Inlet chemical trap |
| 5. Gas ballast valve | 6. Banjo/elbow assembly |
| 7. Solenoid operated pipeline valve | 8. Foreline trap |
| 9. Outlet mist filter | 10. NW25 adaptor |
| 11. Vibration isolators | 12. Oil drain extension |

Table 12 Accessory item numbers

Accessory	Item number
ITO20K Inlet catchpot	A44110000
ITF20K Inlet dust filter	A44215000
ITD20K Inlet desiccant trap	A44510000
ITC20K Inlet chemical trap	A44410000
EMF20 Outlet mist filter	A46229000
PV25EK Valve: 200/240 V, 1-phase, 50/60 Hz	C41301000
PV25EK Valve: 110/127 V, 1-phase, 50/60 Hz	C41303000
FL20K Foreline Trap	A13305000
Vibration isolators (pack of four)	A24801412
ODE 1/4 Oil drain extension	A50503000
Pump inlet adaptor	C10520201
Flexible bellows	C10514670
Pump outlet adaptor	C10501414
Gas ballast banjo/elbow Assembly	A50006003
Gas ballast valve: 110 V, 50/60 Hz	A50006984
Gas ballast valve: 240 V, 50/60 Hz	A50006930

10.2.1 Inlet catchpot

The inlet catchpot traps any liquid droplets and prevents their entry into the pump.

10.2.2 Inlet dust filter

The inlet dust filter protects the pump against abrasive dust.

10.2.3 Inlet desiccant trap

Use a desiccant trap when pumping limited quantities of water vapour at high pumping speeds to a low vapour pressure.

10.2.4 Inlet chemical trap

The inlet chemical trap protects the pump against chemically active gases.

10.2.5 Outlet mist filter

The outlet mist filter separates and traps oil droplets in the pump outlet to prevent oil mist discharge. The mist filter is supplied with an adaptor to connect it to the pump outlet.

10.2.6 Solenoid operated pipeline valve

Fit the pipeline valve between the vacuum system and the pump inlet to provide additional system protection when the pump is switched off.

10.2.7 Foreline trap

Use a foreline trap on a clean pumping system to prevent back-migration of rotary pump oil vapour into the vacuum system.

10.2.8 Vibration isolators

The vibration isolators reduce transmission vibration and noise when the pump is floor or frame mounted and help to reduce strain when the mounting area is uneven.

10.2.9 Oil drain extension

Fit the oil drain extension between the oil drain port on the pump and the oil drain-plug to make the drainage of oil from the pump easier.

10.2.10 Pump inlet adaptor

This is a NW25 to 28 mm bore tube adaptor, supplied with connection hardware. Attach this adaptor to the NW25 pump-inlet to connect 28 mm bore plastic or rubber tube.

10.2.11 Flexible bellows

Use flexible bellows to connect the pump-inlet to the vacuum system. We recommend the use of bellows when using vibration isolators.

10.2.12 Pump outlet adaptor

This is a 3/4 inch BSP to NW25 adaptor. Use this adaptor when removing the hose adaptor supplied fitted to the pump outlet to adapt the 3/4 inch BSP thread to NW25 pump inlet.

10.2.13 Gas ballast banjo/elbow assembly

Use this 3/4 inch BSP assembly when a remote ballast supply or gas ballast valve is fitted.

10.2.14 Gas ballast valve

Use this to control the gas-ballast remotely. The gas ballast banjo/elbow assembly will also be required (refer to [Gas ballast banjo/elbow assembly on page 48](#)) when fitting this accessory.

11. PFPE-prepared EM pumps

If a PFPE-prepared EM pump has been ordered, the pump will be supplied prepared for use with the manufacturers PFPE mechanical pump oils, such as Fomblin YVAC 06/6 and Krytox 1506.

PFPE-prepared EM pumps are suitable for pumping high concentrations of oxygen.

We recommend referring to publication P40040100 (Vacuum pump and Vacuum System Safety) before installing and using a PFPE-prepared EM pump.

11.1 Installation



CAUTION:

Never use hydrocarbon lubricants in a PFPE-prepared pump.

Installation of a PFPE-prepared EM pump is as specified in [Installation on page 19](#), but take note of the caution above.

11.2 Operation



WARNING:

PFPE-prepared EM pumps are suitable for pumping high concentrations of oxygen, but We recommend that a PFPE-prepared EM pump is not used for the pumping of hazardous materials.

Operation of a PFPE-prepared EM pump is as specified in [Operation on page 31](#), but take note of the warning above.

11.3 Maintenance



WARNING:

Obey the safety instructions given below and take note of appropriate precautions. Failure to do so can cause injury to people.

- Take additional care if it is suspected that the pump (and hence the PFPE oil) has overheated.
- Do not touch or inhale the thermal breakdown products of PFPE oil, which may be present, if the pump has been heated to 260 °C and above. PFPE oils are safe in normal use but can decompose into very dangerous substances if they are heated to 260 °C and above. The pump may have overheated if it was misused, if it malfunctioned or if it was in a fire. Safety Data Sheets for PFPE oils used in the pump are available on request: contact us or the supplier.

Fomblin oil has different properties from other pump oils, therefore:

A34310880_T - PFPE-prepared EM pumps

- When filling the PFPE-prepared EM pump with Fomblin oil, we recommend regular checks for oil leaks, particularly around the shaft seals.
- If an oil leak is detected, contact us or the supplier for advice.

12. Service

Our products are supported by a world-wide network of our service centres. Each service centre offers a wide range of options including equipment decontamination, service exchange, repair, rebuild and testing to factory specifications. Equipment which has been serviced, repaired or rebuilt is returned with a full warranty.

The local service centre can also provide our engineers to support on-site maintenance, service or repair of the equipment.

For more information about service options, contact the nearest service centre or our other company.

12.1 Return the equipment or components for service

Before you send your equipment to us for service or for any other reason, you must send us a completed Declaration of Contamination of Vacuum Equipment and Components – Form HS2. The HS2 form tells us if any substances found in the equipment are hazardous, which is important for the safety of our employees and all other people involved in the service of your equipment. The hazard information also lets us select the correct procedures to service your equipment.

We provide instructions for completing the form in the Declaration of Contamination of Vacuum equipment and Components – Procedure HS1.

If you are returning a vacuum pump, note the following:

- If a pump is configured to suit the application, make a record of the configuration before returning the pump. All replacement pumps will be supplied with default factory settings.
- Do not return a pump with accessories fitted. Remove all accessories and retain them for future use.
- The instruction in the returns procedure to drain all fluids does not apply to the lubricant in pump oil reservoirs.

Download the latest documents from www.edwardsvacuum.com/HSForms/, follow the procedure in HS1, fill in the electronic HS2 form, print it, sign it, and return the signed copy to us.



NOTICE:

If we do not receive a completed HS2 form, your equipment cannot be serviced.

