

MX2A Active Thermocouple Vacuum Gauge Part Number: 2-8910-1XX



Operating Specifications ¹	
Operating Range	1 x 10 ⁻⁴ Torr to 1000 Torr
Communications	RS-485
Analog Output	7 selectable 0 V DC to 10 V DC
Programmable Set Points	2
Set Point 1	Open collector
Set Point 2	Relay
Supply Voltage	+22 V DC to +26 V DC
Maximum Power	8 W
Calibration Medium	Dry air or nitrogen
Overpressure	150 psi
Digital Output Resolution	2 significant digits with exponent
Analog Output Resolution	16 bits
Operating Temperature	0 °C to 50 °C
Storage Temperature	-20 °C to 60 °C
Bakeout Temperature	
Brass (P/N: 2-8910-110)	100 °C (electronics removed)
Stainless (P/N: All Others)	200 °C (electronics removed)
Response Time	≤ 2 s
Accuracy	
0.1 mTorr to 1 mTorr	0.1 mTorr resolution
1 mTorr to 10 mTorr	±1 mTorr
10 mTorr to 1 Torr	±10% of reading
1 Torr to 100 Torr	±30% of reading (vertical mount)
100 Torr to 1000 Torr	±10% of reading (vertical mount)
Analog Output	±10 mV
Display Readable Distance	3 m (10 ft)

Physical Characteristics	
Housing	Aluminum
Electrical Connections	D-Sub 15-pin male
Weight with Sensor (typical)	345 g (0.76 lbs)
Weight without Sensor	186 g (0.41 lbs)
Dimensions	See dimensional drawings

Sample RS-485 Commands (assume address 0) ²	
*OR1<CR>	Read units
*OR2<CR>	Read SP1L and SP1H
*OW10001<CR>	Set units to Pascal
*OW10002<CR>	Set units to Torr
*OW10003<CR>	Set units to Millibar
*OW2XXXXXXX<CR>	Set SP1 low and high values
*OS1<CR>	Read vacuum

- ### Benefits
- Simple sensor replacement - no screws to remove
 - Competitively priced
 - Compact design with an easy to read color OLED display
 - Excellent resolution and accuracy of measurements
 - Superior unit to unit performance
 - Excellent customer support
 - Designed and manufactured in the United States of America

Description

The MX2A Active Gauge utilizes an easily replaceable (no screws) Televac 2A thermocouple vacuum sensor. It has a variety of features including a wide range of measurement from 1 x 10⁻⁴ Torr up to 1000 Torr, RS-485 communications, two programmable set points, and a selectable analog output. The bright OLED display makes it easy to read from a distance.

Options can be set from four capacitive touch controls located on the top of the unit or through RS-485 communications. The extensive selection of fittings, simplicity of use, ease of sensor replacement, and competitive cost make this unit an excellent choice for a variety of vacuum applications.

- ### Applications
- Heat treatment and vacuum furnaces
 - Thin film deposition and coating processes
 - Cryogenics
 - Pharmaceutical product processes

Visit the Televac website at www.frederickscompany.com for a full list of applications.

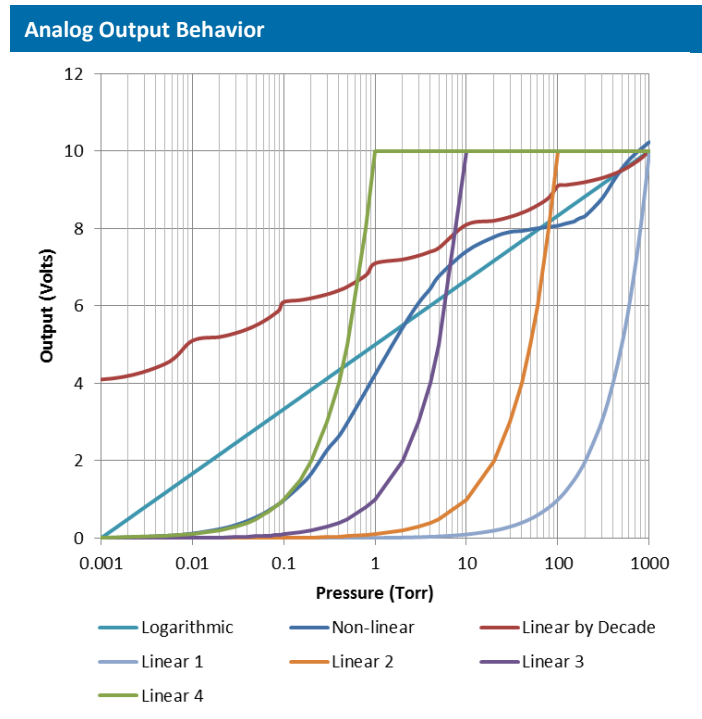

- ### Ratings and Compliance
- Certified to CAN/CSA C22.2 No. 61010-1-12
 - CE certified to EN 61010-1, EN 61236-1, EN 55011
 - RoHS
 - IP40
 - EAC certified

¹ See the Televac website at www.frederickscompany.com for a list of definitions for terms. All test data was acquired at 23 °C.

² See the MX2A Instruction Manual for RS-485 command descriptions and setup instructions.

MX2A Active Thermocouple Vacuum Gauge Part Number: 2-8910-1XX



Electrical Connections

Pin	Description
1	Analog Out (Ground)
2	RS-485 A (-)
3	SP2 NC
4	SP2 NO
5	SP1 Open Drain
6	Floating
7	Floating
8	Supply Voltage (+)
9	Analog Out (0 to 10) V
10	RS-485 B (+)
11	SP2 Com
12	SP1 Source
13	Floating
14	Floating
15	Supply Voltage (-)

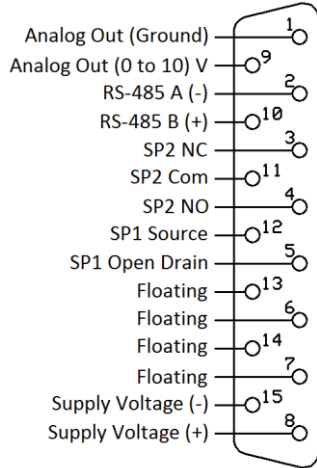

Materials Exposed to Vacuum

MX2A PN: 2-8910-110, -116, -125	MX2A P/N: All Others
Nickel	Nickel
Glass	Glass
Gold	Gold
Tophet	Tophet
Cupron	Cupron
Solder	Stainless Steel

Set Points

The MX2A has two set points. Set point 1 is an N-Channel 60 V MOSFET open collector. It has a maximum current rating of 1 A. The data sheet can be found at www.vishay.com/docs/69958/si2308bd.pdf. Set point 2 is a relay with a maximum switching voltage of 220 V DC (250 V AC) and a maximum switching current of 2A. The data sheet can be found at www.te.com/catalog/pn/en/1393788-3.

Related Products and Replacement Sensors

2A Nickel Plated Brass Sensor	Part Number
1/8" NPT	2-2100-10
NW16 (DN16 ISO-KF)	2-2100-016
NW25 (DN25 ISO-KF)	2-2100-025

2A Stainless Steel Sensor	Part Number
1/8" NPT	2-2126-01
1/2" Straight	2-2126-11
NW16 (DN16 ISO-KF)	2-2126-30
NW25 (DN25 ISO-KF)	2-2126-31
NW40 (DN40 ISO-KF)	2-2126-32
1.33" CF (DN16 ISO-CF-F)	2-2126-50
2.75" CF (DN40 ISO-CF-F)	2-2126-52

MP7ER Active Gauge - This gauge measures high vacuum from 1×10^{-8} Torr up to 1×10^{-2} Torr. Combining it with the MX2A provides a full range (ATM to UHV) active gauge measurement solution.

Visit the Televac website at www.frederickscompany.com for a full list of products.

Dimensional Drawings

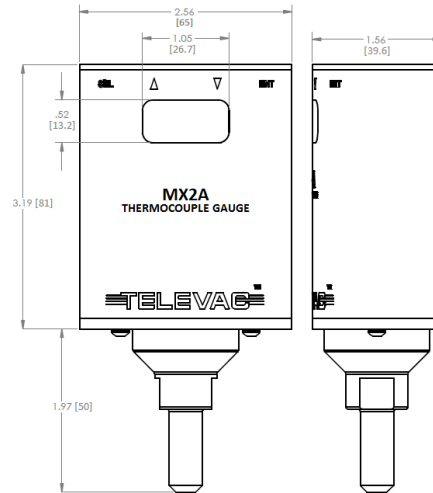

*Dimensions are drawn with 1/8" NPT fitting installed

Ordering Information

MX2A	Part Number
1/8" NPT Stainless Steel	2-8910-101
1/8" NPT Nickel Plated Brass	2-8910-110
1/2" Straight Stainless Steel	2-8910-111
NW16 (DN16 ISO-KF) Nickel Plated Brass	2-8910-116
NW16 (DN16 ISO-KF) Stainless Steel	2-8910-130
NW25 (DN25 ISO-KF) Nickel Plated Brass	2-8910-125
NW25 (DN25 ISO-KF) Stainless Steel	2-8910-131
NW40 (DN40 ISO-KF) Stainless Steel	2-8910-132
1.33" CF (DN16 ISO-CF-F) Stainless Steel	2-8910-150
2.75" CF (DN40 ISO-CF-F) Stainless Steel	2-8910-152

VCR and VCO available upon request

D-Sub 6 Conductor Cable (flying leads)	Part Number
20 ft (6 m)	2-9857-020
50 ft (15 m)	2-9857-050
100 ft (30 m)	2-9857-100

D-Sub 15 Conductor Cable (flying leads)	Part Number
20 ft (6 m)	2-9858-020
50 ft (15 m)	2-9858-050
100 ft (30 m)	2-9858-100

Wall Power Supply	Part Number
100-240 V AC/47-63 Hz, plug types A, C, G, I	2-7900-097

Contact Us

Televac - The Fredericks Company
 2400 Philmont Avenue
 Huntingdon Valley, PA 19006

tel: +1 215 947 2500

email: sales@frederickscompany.com

web: www.frederickscompany.com

Disclaimer: Specifications subject to change without notice. The Fredericks Company assumes no responsibility for inaccuracies in product specifications or any liability arising from product use.
 © 2016 The Fredericks Company