



**MX200 Vacuum Controller  
Instruction Manual  
Rev C**



© 2018 Televac® - The Fredericks Company  
2400 Philmont Avenue  
Huntingdon Valley, PA 19006  
web: [www.frederickscompany.com](http://www.frederickscompany.com)  
email: [sales@frederickscompany.com](mailto:sales@frederickscompany.com)  
tel: +1 215-947-2500  
fax: +1 215-947-7464

# Table of Contents

<b>1. Description, Specifications, and Part Numbers</b>	<b>5</b>
1.1 Description	5
1.2 Specifications	5
1.3 MX200 Part Numbers	6
<b>2. Safety Information</b>	<b>7</b>
2.1 General Safety Information	7
<b>3. Quick Start Guide</b>	<b>8</b>
3.1 Check what you've received	8
3.2 Safety Instructions	8
3.3 Check the MX200 Power Supply Switch	8
3.4 Connect Power	8
3.5 Turn on the MX200!	8
3.6 Check the Measurement Screen	8
3.7 Power Down the MX200 and Connect Peripherals	8
3.8 Enjoy Your MX200	8
<b>4. Physical Characteristics</b>	<b>9</b>
4.1 Enclosure	9
4.2 Mounting	10
4.3 Labeling	10
<b>5. Electrical Requirements</b>	<b>11</b>
5.1 Power	11
5.2 Selecting the Supply Voltage	11
5.3 Electrostatic Discharge Sensitivity	11
<b>6. Environmental Specifications</b>	<b>12</b>
6.1 Temperature	12
6.2 Humidity	12
6.3 Altitude	12
<b>7. User Interface</b>	<b>13</b>
7.1 Display	13
7.2 Touch Controls	13
7.3 Menu Structure	14
<b>8. Measurement Screen</b>	<b>15</b>
8.1 Description	15
8.2 Selecting Channels to Display	15
8.3 Zero Channel Display	16
8.4 Units of Measurement	16
8.5 Resolution of Measurements	16
8.6 Sampling Rate	17
8.7 Leak Rate	17
<b>9. Digital Communications</b>	<b>18</b>
9.1 READ THIS FIRST - Important Note on Establishing Communication	18
9.2 Communication Modules	18
9.3 Switching Communication Modes or Viewing the Current Mode	18
9.4 RS-232 Interface Description	18
9.5 RS-485 Interface Description	19
9.6 USB Interface Description	19
9.7 Connecting to a PC and Establishing Communication	19
9.8 Full List of Commands	20
9.9 Notes on Commands	21
9.10 Detailed Command Descriptions	21
9.11 Error Codes	37
<b>10. Analog Outputs</b>	<b>38</b>
10.1 Description	38

10.2	Changing the Analog Output Function .....	38
10.3	Notes on Logarithmic Analog Output Mode .....	38
10.4	Notes on Linear Analog Output Mode .....	38
10.5	Notes on Linear-by-Decade Analog Output Mode .....	38
10.6	Refresh Rate .....	39
10.7	Analog Output Functions .....	39
<b>11.</b>	<b>Set Points .....</b>	<b>45</b>
11.1	Description .....	45
11.2	Set Point Channel Association .....	45
11.3	Set Point On and Off Values .....	45
<b>12.</b>	<b>Calibration .....</b>	<b>46</b>
12.1	READ THIS FIRST - WARNING .....	46
12.2	Description .....	46
12.3	NIST and Standard Calibration .....	46
12.4	Calibration Points .....	46
12.5	Calibration Frequency .....	46
12.6	Gases .....	47
12.7	Gas Selection .....	47
<b>13.</b>	<b>Modules, Sensors, and Cables .....</b>	<b>48</b>
13.1	Module Description .....	48
13.2	Removing and Replacing Modules .....	48
13.3	Sensor Description .....	48
13.4	1E .....	48
13.5	1F .....	49
13.6	2A .....	50
13.7	4A .....	50
13.8	7B .....	51
13.9	7E .....	52
13.10	7F .....	53
13.11	7FC .....	53
13.12	7FCS .....	54
13.13	5A .....	55
13.14	5B .....	55
13.15	5C .....	55
13.16	5D .....	56
13.17	5E .....	56
13.18	5F .....	56
13.19	Set Point Relay Module .....	57
13.20	Power Supply Module .....	57
13.21	RS-232/RS-485/USB Communications Module and Lockout Switch .....	58
13.22	Additional Notes on Modules, Sensors, and Cables .....	58
<b>14.</b>	<b>High Vacuum Measurement .....</b>	<b>59</b>
14.1	Description .....	59
14.2	Changing Between Auto and Manual Modes .....	59
14.3	Manual High Vacuum Switching .....	59
14.4	Automatic High Vacuum Switching .....	59
14.5	Additional Notes .....	59
<b>15.</b>	<b>Cleaning Sensors .....</b>	<b>60</b>
15.1	Description .....	60
15.2	2A and 4A Thermocouple and Convection Cleaning .....	60
15.3	General Information on Cold Cathode Cleaning .....	60
15.4	7B Cold Cathode Cleaning .....	61
15.5	7E Cold Cathode Cleaning .....	63
15.6	7FC and 7FCS Cold Cathode Cleaning .....	65
<b>16.</b>	<b>Understanding Cold Cathodes .....</b>	<b>67</b>
16.1	Description .....	67

<b>17. Capacitance Diaphragm Gauges (CDGs)</b> .....	<b>68</b>
17.1 Description .....	68
<b>18. Firmware Upgrades and the Bootloader</b> .....	<b>69</b>
18.1 Description .....	69
18.2 Upgrading the Firmware .....	69
18.3 Hardware Bootloader .....	70
<b>19. Software Versioning</b> .....	<b>71</b>
19.1 Description .....	71
<b>20. Certifications</b> .....	<b>72</b>
20.1 CE .....	72
20.2 UL .....	72
20.3 RoHS .....	72
20.4 REACH .....	72
<b>21. Troubleshooting</b> .....	<b>73</b>
21.1 Cold Cathode Switching .....	73
<b>22. Vacuum Measurement Unit Conversions</b> .....	<b>74</b>
22.1 Converting Between Torr Scientific, Torr Decimal, mTorr, and Microns .....	74
<b>23. Revision History</b> .....	<b>75</b>

# 1. Description, Specifications, and Part Numbers

## 1.1 Description

- 1.1.1 The MX200 is a modular, rack-mountable vacuum controller which controls up to ten vacuum sensors including cold cathode, convection, diaphragm, and thermocouple sensors. It also controls select capacitance diaphragm gauges (CDGs) from other manufacturers making it an extremely versatile solution for any vacuum measurement application. The capability of controlling a wide range of sensors allows the MX200 to provide a maximum vacuum measurement range of  $1 \times 10^{-11}$  Torr to 10,000 Torr.

The MX200 includes standard communications of USB, RS-232, and RS-485 standard. The user interface includes six capacitive touch controls and a high contrast green OLED display with a 180° viewing angle. All features are accessible through the front panel or through the digital communications. The digital communications also allow the MX200's operating system to be upgraded in the field.

The Televac brand of The Fredericks Company was created in 1935 and is an industry leader in vacuum measurement technology. Our team of engineers and application specialists deliver broad practical knowledge and experience across a wide range of markets and application areas. In keeping with the company's history of outstanding customer support, Televac provides the insight and guidance needed to take design concepts to reality in a cost-effective manner. For more information, visit our website at [www.frederickscompany.com](http://www.frederickscompany.com).

## 1.2 Specifications

<b>Operating Range</b>	1*10 <sup>-11</sup> Torr to 10,000 Torr maximum
<b>Communications</b>	RS-232/RS-485/USB (standard)
<b>Analog Output</b>	0 V DC to 10 V DC (1 per sensor)
<b>Analog Output Resolution</b>	16 bits
<b>Programmable Set Points</b>	4 per module, 8 maximum
<b>Set Point Type</b>	Relay
<b>Supply Voltage</b>	115/230 V AC (2/1 A), 50/60 Hz
<b>Maximum Power</b>	230 W
<b>Calibration Medium</b>	Dry air or nitrogen
<b>Operating Temperature</b>	0 °C to 50 °C
<b>Storage Temperature</b>	-20 °C to 70 °C
<b>Display Readable Distance</b>	Up to 5 m (16 ft)
<b>Maximum Sensors Controlled</b>	10
<b>Maximum Sensors Displayed</b>	8

### 1.3 MX200 Part Numbers

Description	Part Number
MX200 Controller Base Unit	2-7900-034
Quad Relay Module	2-6200-211
USB/RS-232/RS-485 Communications Module	2-6200-304
1E Piezo Diaphragm Module	2-6200-220
1F Piezo Diaphragm Module	2-6200-244
2A Dual Thermocouple Module	2-6200-186
4A Dual Convection Module	2-6200-215
7B Penning Magnetron Cold Cathode Module	2-6200-227
7E/F/FC/FCS Double Inverted Magnetron Cold Cathode Module	2-6200-285
Dual Capacitance Diaphragm Module	2-6200-252

## 2. Safety Information

### 2.1 General Safety Information



2.1.1 All maintenance and repairs must be completed by a trained technician. There are no user serviceable parts inside the unit and no parts should be substituted or modified without approval from the factory. Refer to the factory for all information related to maintenance and repairs.



2.1.2 Always power down and disconnect power from the unit before attempting to perform service. Use the power cord as the main disconnect to remove all power from the unit.



2.1.3 This unit can be used with 110 V AC or 220 V AC power. There is a switch on the back of the unit to change between the two settings. Failure to use a correct power source may cause damage to the unit. See Section 5 for more information.



2.1.4 Hazardous high voltages (2 kV to 4 kV) are present when any cold cathode modules are installed. This includes the 7B/E/F/FC/FCS modules.



2.1.5 Strong magnetic fields are present near cold cathode sensors.



2.1.6 Take proper precautions to avoid hazardous overpressure conditions.



2.1.7 Televac and The Fredericks Company are not liable for any direct or indirect damages that result from the use of the MX200 or its peripherals.

## 3. Quick Start Guide

### 3.1 Check what you've received

- 3.1.1 Compare what you've received to your purchase order. Note that while listed as separate items, the modules for the MX200 are shipped pre-installed in the MX200 base unit from the factory for your convenience.

### 3.2 Safety Instructions

- 3.2.1 Review all safety instructions outlined in Section 2.

### 3.3 Check the MX200 Power Supply Switch

- 3.3.1 Ensure that the MX200 power supply switch is set to the correct voltage. The options are 110 V AC and 220 V AC. Selecting the incorrect voltage will cause damage to the unit. See Section 5 for more information.

### 3.4 Connect Power

- 3.4.1 Connect the power cord provided with the MX200 to a suitable power supply.

### 3.5 Turn on the MX200!

- 3.5.1 This is the moment you've been waiting for. Flip the power switch on the power supply on the back of the MM200 (beneath where the power cord is connected). The loading screen should now be displayed and appear as follows:

```
TELEVAC MX200  
OS XXXXXX  
LOADING XX/100
```

### 3.6 Check the Measurement Screen

- 3.6.1 After a few seconds, the MX200 will complete its startup sequence and load the measurement screen. With no cables or sensors connected, all displayed channels should read **OVER**, **READY**, or **OFF**.

### 3.7 Power Down the MX200 and Connect Peripherals

- 3.7.1 Once you've confirmed that the MX200 is functional, power it down. Connect all sensors using sensor cables, and connect any analog output, set point, or digital communications cables as necessary. Be sure to follow all safety precautions associated with these items and your system.

### 3.8 Enjoy Your MX200

- 3.8.1 We love the MX200 and we know you will too. Please don't hesitate to contact us with any questions or comments!

## 4. Physical Characteristics

### 4.1 Enclosure

4.1.1 The MX200 has an aluminum enclosure. The dimensions are the same as the existing MM200 and are shown below:

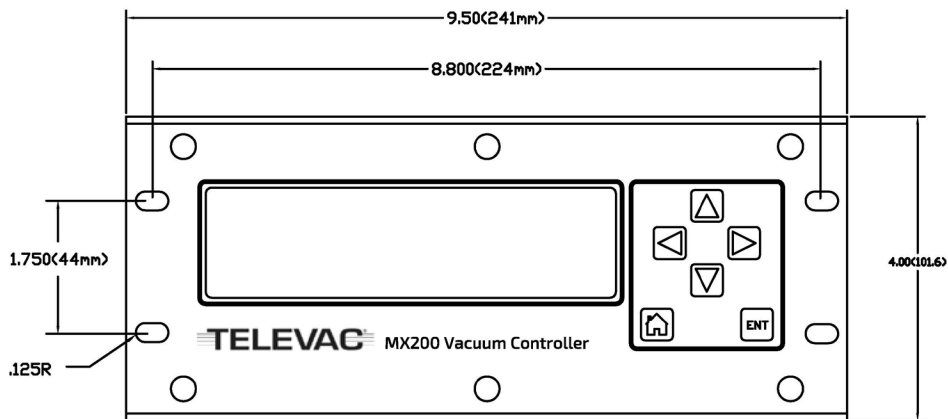
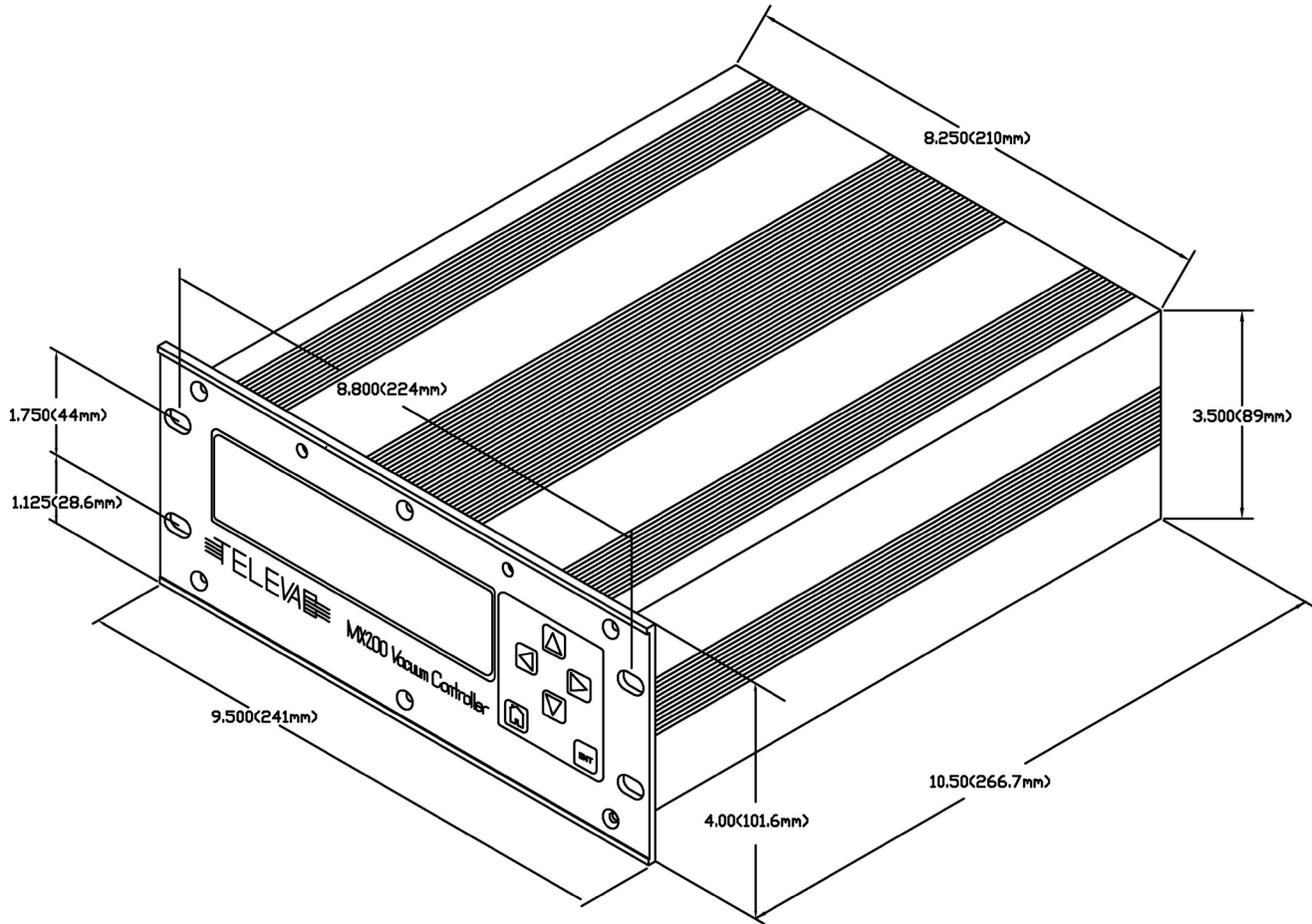

## 4.2 Mounting

### 4.2.1 Free Standing

4.2.1.1 The MX200 can be used as a free standing unit, four rubber feet are shipped with each unit. When used as a free standing unit it must be secured to the mounting surface.

### 4.2.2 Panel Mounted

4.2.2.1 A panel cutout of 89 mm x 210 mm (3.50" x 8.25") is required for the unit.

### 4.2.3 Rack Mounted

4.2.3.1 The mounting hole vertical spacing is 44 mm (1.175").

## 4.3 Labeling

4.3.1 The MX200 is labeled with a CE/UL compliance label, a calibration label, and a serial number label. All units are given a unique serial number before being shipped by Televac.

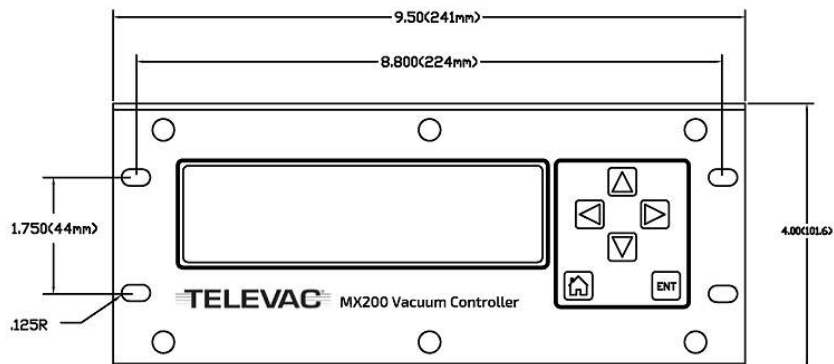
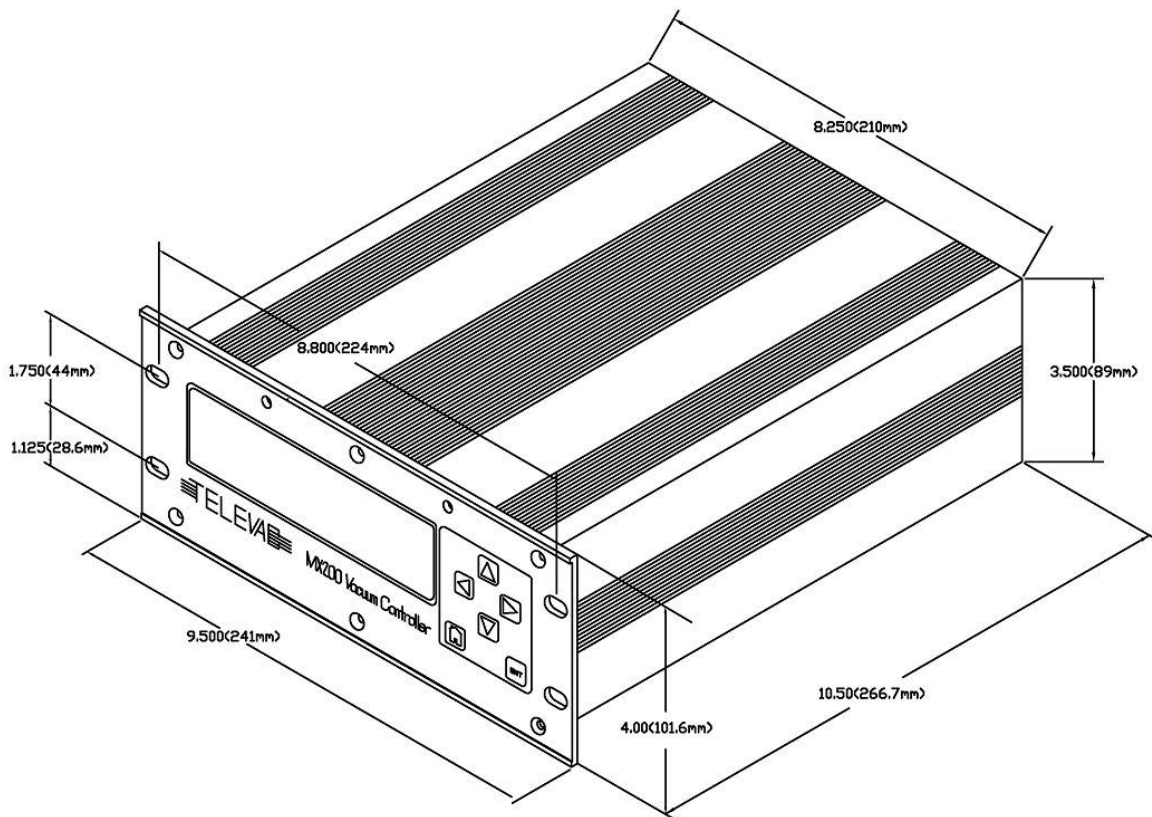

## 5. Electrical Requirements

### 5.1 Power

<b>Supply Voltage</b>	110/220 V AC $\pm$ 10%, 50/60 Hz
<b>Supply Current</b>	2A @ 115 V AC, 1A @ 230 V AC
<b>Power</b>	230 W maximum
<b>Power Connection</b>	Power cord (IEC 60320 C-13)

### 5.2 Selecting the Supply Voltage

- 5.2.1 There is a switch located above the power supply connection on the back of the unit. Verify that this switch is in the correct position before connecting power to the unit.

### 5.3 Electrostatic Discharge Sensitivity

- 5.3.1 The MX200 contains ESD-sensitive components but is designed to withstand  $\pm$ 2 kV discharges using the human body model.

## 6. Environmental Specifications

### 6.1 Temperature

<b>Operating Temperature</b>	0° to +50° C
<b>Storage Temperature</b>	-20° to +70° C

### 6.2 Humidity

<b>Operating Humidity</b>	10% to 90% non-condensing relative humidity
<b>Storage Humidity</b>	10% to 90% non-condensing relative humidity

### 6.3 Altitude

<b>Operating Altitude</b>	Sea level to 2,000 m (6,500 feet)
<b>Storage Altitude</b>	Sea level to 2,000 m (6,500 feet)

## 7. User Interface

### 7.1 Display

<b>Type</b>	Green OLED
<b>Resolution</b>	256 x 64 pixels
<b>Viewing Area</b>	35 mm x 136 mm (1.38" x 5.35")
<b>Viewing Distance</b>	Up to 5 m (16 ft), dependent on number of channels displayed

### 7.2 Touch Controls

<b>Type</b>	Capacitive switch
<b>↑ Button</b>	Move the cursor up or adjust a value up
<b>→ Button</b>	Move into menu at cursor or move right one digit
<b>← Button</b>	Go back one menu or move left one digit
<b>↓ Button</b>	Move the cursor down or adjust a value down
<b>ENT Button</b>	Save a new setting or value
<b>⏠ (Home) Button</b>	Return to the main menu

- 7.2.1 Capacitive touch controls do not provide any tactile feedback, so audible feedback is generated when a control is pressed.

## 7.3 Menu Structure

- 7.3.1 Measurements
  - 7.3.1.1 Measurement Screen
- 7.3.2 Channel Setup
  - 7.3.2.1 Channel 1 ... Channel 10
    - 7.3.2.1.1 Display
    - 7.3.2.1.2 Gas
    - 7.3.2.1.3 Resolution
    - 7.3.2.1.4 Analog Out
    - 7.3.2.1.5 Restore Defaults
- 7.3.3 Calibration
  - 7.3.3.1 Channel 1 ... Channel 10
    - 7.3.3.1.1 Sensor dependent
- 7.3.4 Global Setup
  - 7.3.4.1 Measurement Screen
    - 7.3.4.1.1 Channel 1 ... Channel 10
  - 7.3.4.2 Units
    - 7.3.4.2.1 Pascal
    - 7.3.4.2.2 Torr
    - 7.3.4.2.3 mbar
    - 7.3.4.2.4 Torr Dec
    - 7.3.4.2.5 mT|Torr
  - 7.3.4.3 Gas
    - 7.3.4.3.1 Channel 1 ... Channel 10
  - 7.3.4.4 Communications
    - 7.3.4.4.1 RS-232
      - 7.3.4.4.1.1 Baud Rate
    - 7.3.4.4.2 RS-485
      - 7.3.4.4.2.1 Address
      - 7.3.4.4.2.2 Baud Rate
    - 7.3.4.4.3 USB
      - 7.3.4.4.3.1 Baud Rate
  - 7.3.4.5 Cold Cathode
    - 7.3.4.5.1 Mode
    - 7.3.4.5.2 Even Status
    - 7.3.4.5.3 Odd Status
    - 7.3.4.5.4 Switch Point
  - 7.3.4.6 Restore All Defaults
- 7.3.5 Set Points
  - 7.3.5.1 Set Point 1 ... Set Point 8
    - 7.3.5.1.1 On
    - 7.3.5.1.2 Off
    - 7.3.5.1.3 Channel
- 7.3.6 Version Information

## 8. Measurement Screen

### 8.1 Description

- 8.1.1 The measurement screen displays the output from 0 channels up to 8 channels and scales the text size accordingly. In addition to measurements, it also simultaneously displays the units of measurement (Torr, mbar, Pascal, Torr decimal, or mTorr/Torr, note that mTorr is equivalent to microns) and the active set points. The measurement screen comes up automatically when the unit is powered. To exit the measurement screen and enter other menus, press the left or home button.
- 8.1.2 Auto-scaling measurement screen examples:



### 8.2 Selecting Channels to Display

- 8.2.1 To select which channels to display, press the home button then navigate to:

Global Setup>Measurement Screen

This will show a list of all channels. The display status of all connected channels is shown as “yes” or “no”. To switch a channel between yes and no, move the cursor to the desired channel using the up and down buttons, then press the ENT button. If more than 6 channels are connected, continue scrolling down to view additional channels. Turning a channel display on or off can also be accomplished through digital communications. Refer to Section 9.0 for more information.

Another way to select which channels to display is to press the home button then navigate into:

Channel Setup>Channel X

Using the up and down buttons, scroll the cursor to the “Display: Yes/No” row and press the ENT button to change the current setting. Pressing the left or home button without pressing ENT will exit the menu without saving any changes.

## 8.3 Zero Channel Display

- 8.3.1 This feature is designed for applications where the MX200 output is connected to another controller through the 0 to 10 V DC analog outputs of each sensor. In this situation, due to conversion and latency, there can be a mismatch between the measurements on the front panel of the MX200 and the other controller. Turning off the front panel measurements removes any concerns related to this mismatch. When displaying zero channels, the measurement screen will appear as follows:



## 8.4 Units of Measurement

- 8.4.1 The MX200 supports units of Torr, mbar, Pascal, Torr decimal, and mTorr/Torr (mTorr is equivalent to microns). Torr decimal displays the output in decimal notation instead of scientific notation. mTorr/Torr switches the units of measurement to mTorr (microns) between 1 mTorr and 999 mTorr for rough vacuum sensors. Note that Torr decimal and mTorr/Torr notation only apply to rough vacuum sensors such as the Televac 2A and 4A. To change the units of measurement, press the home button then navigate into:

Global Setup>Units

The currently selected units of measurement are displayed at the top of the list. Scroll to a different option and press ENT to change the units. Press the left or home button to exit the menu. Pressing the left or home button without first pressing ENT will exit the menu without saving a new setting.

## 8.5 Resolution of Measurements

- 8.5.1 Channel measurements can be set to high or standard resolution. More details about these options are described below for different measurement units. The resolution for a specific channel can be changed by pressing the home button then navigating to:

Channel Setup>Channel X>Resolution Std/High

The currently selected resolution is displayed at the top of the list. Scroll to a different option and press ENT to change the resolution. Press the left or home button to exit the menu. Pressing the left or home button without first pressing ENT will exit the menu without saving a new setting.

8.5.2 Resolution when the units are set to Torr, mbar, or Pascal:

Range (Torr)	High Resolution	Standard Resolution
Full range	3 significant digits	2 significant digits

8.5.3 Resolution when the units are set to Torr decimal:

Range (Torr)	Standard or High Resolution
100 to 1000	1 Torr
10 to 100	0.1 Torr
1 to 10	0.01 Torr
0.001 to 1	0.001 Torr

8.5.1 Resolution when the units are set to mTorr/Torr (mTorr is equivalent to microns):

Range (mTorr)	Standard or High Resolution
1 to 999	1 mTorr

## 8.6 Sampling Rate

8.6.1 The readings for all vacuum sensors connected to the MX200 are sampled at a minimum rate of 100 Hz.

## 8.7 Leak Rate

8.7.1 To enter the leak rate mode, press the up arrow then ENT to start the leak rate calculation and the down arrow then ENT to stop the calculation. This can only be done while in the measurement screen. The leak rate is displayed in mTorr (mTorr is equivalent to microns) regardless of the settings for units of measurement, and is only calculated for channel 1. The channel 1 measurement will rotate between the channel 1 measurement and the leak rate, with the measurement displaying for 2 seconds and the leak rate displaying for 1 second.

After entering the leak rate mode, the unit requires 15 seconds to make the first calculation. During this time the display will show "LR" until the leak rate is calculated. If the leak rate calculation has already been started through digital communications, it must be stopped through the front panel (down arrow then ENT button), or through digital communications before it can be started again. See section 9 for more information.

There is a timeout for the leak rate calculation after 9 hours.

## 9. Digital Communications

### 9.1 READ THIS FIRST - Important Note on Establishing Communication

- 9.1.1 NOTE THAT COMMANDS THAT SAVE OR CHANGE VALUES STORED IN MEMORY CAN ONLY BE USED WHEN THE MX200 IS IN THE MEASUREMENT SCREEN. If the MX200 is not in the measurement screen when a save or change command is used, an error code of 0N0000 will be returned.

All other commands can be accessed from any a screen. ALSO NOTE THAT ONLY THE SELECTED MODE OF COMMUNICATION WILL BE FUNCTIONAL. See Section 9.3 for methods of switching the communication modes or viewing the current mode.

### 9.2 Communication Modules

- 9.2.1 There is one communication module for the MX200. The USB/RS-232/RS-485 module is included with every MX200.

### 9.3 Switching Communication Modes or Viewing the Current Mode

- 9.3.1 The MX200 can be switched between communication modes or the current mode can be viewed by pressing the home button and navigating to:

Global Setup>Communications>Interface

The current mode can then be viewed or a new mode can be selected by pressing ENT on the desired mode. Only one mode of communication can be active at any given time.

### 9.4 RS-232 Interface Description

- 9.4.1 RS-232 Interface Description

<b>Interface</b>	D-sub 9 pin female port on communications module
<b>Baud Rates</b>	9600, 14400, 19200, 38400, 57600, or 115200 (default)
<b>Data Format</b>	8 data bits, 0 parity bits, 1 stop bit
<b>Error Detection</b>	None
<b>Transfer Distance</b>	10 m (30 ft)

- 9.4.2 Pin Diagram

Pin	Signal Description
1	Ground
2	RS-232 TX
3	RS-232 RX
4	No Connection
5	Ground
6	No Connection
7	Ground
8	No Connection
9	Ground

## 9.5 RS-485 Interface Description

### 9.5.1 Description

<b>Interface</b>	3 position screw terminal block on communications module
<b>Addresses</b>	00 to 99 (decimal), default value of 00
<b>Baud Rates</b>	9600, 19200, 38400, 57600, or 115200 (default)
<b>Data Format</b>	8 data bits, 0 parity bits, 1 stop bit
<b>Error Detection</b>	None
<b>Transfer Distance</b>	300 m (1000 ft)
<b>Maximum Nodes on Bus</b>	16

### 9.5.2 3 Position Screw Terminal Block Pin Diagram

Pin	Signal Description
1	RS-485 B
2	RS-485 A
3	Ground

## 9.6 USB Interface Description

### 9.6.1 Description

<b>Interface</b>	USB type B receptacle on communications module
<b>Type</b>	USB 2.0
<b>Class</b>	USB communications device class (USB CDC)
<b>Baud Rates</b>	9600, 19200, 38400, 57600, and 115200

## 9.7 Connecting to a PC and Establishing Communication

- 9.7.1 Televac suggests the use of USB communications when connecting the MX200 to a PC. Televac also suggests the use of the free serial communications software Tera Term to send and receive commands from the unit. Detailed instructions for establishing communication between a PC and any of our products can be found in Televac Application Note 3008, please contact Televac to request this document.

## 9.8 Full List of Commands

Command	Sample Output	Description
R1<cr>	XX<cr><lf>	Outputs units setting XX: PA=Pascal, TR=Torr, MB=mBar, TD=Torr decimal, MT=mTorr/Torr
W1XX<cr>	XX<cr><lf>	Set units to XX: PA=Pascal, TR=Torr, MB=mBar, TD=Torr decimal, MT=mTorr/Torr
S1XX<cr>	ppsee<cr><lf>	Vacuum reading for channel XX is ppsee
S1<cr>	XX=ppsee ... XX=ppsee<cr><lf>	Output ppsee readings for every channel XX
S2<cr>	NNNNNN<cr><lf>	Logic firmware version
S3<cr>	NNNNNN<cr><lf>	Display firmware version
S4<cr>	XX=YY ... XX=YY<cr><lf>	Output channel sensor types: XX = channel number, YY = sensor type
S5<cr>	XX=YY ... XX=YY<cr><lf>	Output set point XX status YY (ON=on, OF=off, 00=no set point connected)
S6<cr>	Televac ... <cr><lf>	Output all setup information
RC1XX<cr>	Baa<cr><lf>	Output first calibration point for channel XX
RC2XX<cr>	Baa<cr><lf>	Output second calibration point for channel XX
RC3XX<cr>	Baa<cr><lf>	Output third calibration point for channel XX, return error if point doesn't exist
RC4XX<cr>	Baa<cr><lf>	Output fourth calibration point for channel XX, return error if point doesn't exist
WC1XXBaa<cr>	PPSEE<cr><lf>	Set first calibration point for channel XX
WC2XXBaa<cr>	PPSEE<cr><lf>	Set second calibration point for channel XX
WC3XXBaa<cr>	PPSEE<cr><lf>	Set third calibration point for channel XX, return error if point doesn't exist
WC4XXBaa<cr>	PPSEE<cr><lf>	Set fourth calibration point for channel XX, return error if point doesn't exist
R2<cr>	01 02 03 04 05 ... <cr><lf>	Outputs channel numbers connected to the MX200
R3XX<cr>	HI<cr> or LO<cr><lf>	Outputs HI/LO resolution for channel XX
W3XX<cr>	HI<cr> or LO<cr><lf>	Toggle HI/LO resolution for channel XX
R4<cr>	01 02 03 04 05 ... <cr><lf>	Outputs channel numbers set to display on measurement screen
W4XX<cr>	ON<cr> or OF<cr><lf>	Adds or removes channel XX from measurement screen
R5XX<cr>	FbaaBAA<cr><lf>	Output analog output format, high and low values
W5XXF<cr>	F<cr><lf>	Set channel XX analog output format to linear-by-decade (lin/dec=3, lin/dec 7E=4)
W5XX1baa<cr>	Fbaa<cr><lf>	Set channel XX analog output format to linear: baa=high value
W5XX2baaBAA<cr>	FbaaBAA<cr><lf>	Set channel XX analog output format to linear: baa=high value, BAA=low value
R6XX<cr>	GG<cr><lf>	Output gas setting for channel XX
W6XXGG<cr>	GG<cr><lf>	Set channel XX to gas type to GG
R7Y<cr>	ppseePPSEEZZ<cr><lf>	Output relay Y on = ppsee, relay Y off = PPSEE, and channel ZZ assigned to relay Y
W7YppseePPSEEZZ<cr>	ppseePPSEE<cr><lf>	Set relay Y on to ppsee, relay Y off to PPSEE, and relay Y to channel ZZ
R8<cr>	A<cr><lf>	Outputs the cold cathode mode, A (auto = 1, self = 2)
W8A<cr>	A<cr><lf>	Sets the cold cathode mode, A (auto = 1, self = 2)
R9<cr>	BB<cr><lf>	Returns the cold cathode switch point value, BB (01 to 50)
W9BB<cr>	BB<cr><lf>	Sets the cold cathode switch point value, BB (01 to 50)
R10<cr>	CD<cr><lf>	Returns the cold cathode status odd and even (on/off) C-odd, D-even (0 = off, 1 = on)
W10CD<cr>	CD<cr><lf>	Sets the cold cathode status odd and even (on/off) C-odd, D-even (0 = off, 1 = on)
C1TTTT<cr>	TTTT<cr><lf>	Set baud rate to TTTT
C2EE<cr>	EE<cr><lf>	Set address to EE (00 to 99), RS-485 only
C4N<cr>	N<cr><lf>	Change I/O to N (RS-232=1, RS-485=2, USB=3)
C1<cr>	TTTT<cr><lf>	Output baud rate setting
C2<cr>	EE<cr><lf>	Output address for RS-485
C4<cr>	N<cr><lf>	Output communications type (RS-232=1, RS-485=2, USB=3)
HM<cr>	M<cr><lf>	Return to the measurement screen
RLR<cr>	SXXX<cr>	Output the leak rate calculation or channel 1 in mTorr (S=sign, XXX=-999 to 999)
WLRX<cr>	X<cr><lf>	Turn on or off leak rate calculation for channel 1 (0=off, 1=on)
WD_1XX<cr>	XX<cr><lf>	Restore channel setup defaults for channel XX
WD_7X<cr>	X<cr><lf>	Restore set point relay defaults for set point X
WD_CXX<cr>	XX<cr><lf>	Restore calibration defaults for channel XX
WD_G<cr>	D<cr><lf>	Restore defaults for global setup
SN<cr>	NNNNNN<cr><lf>	Returns the six digit serial number of the unit, with values from 000000 to 999999
PG_LGC<cr>	Bootloader ... <cr><lf>	Enters the bootloader for the logic firmware
PG_DSP<cr>	Bootloader ... <cr><lf>	Enters the bootloader for the display firmware

## 9.9 Notes on Commands

- 9.9.1 All commands are appended with a carriage return (<cr>, ASCII 0x0D) and all responses are appended with a carriage return and line feed (<cr><lf>, ASCII 0x0D 0x0A).
- 9.9.2 For RS-485 communications, all commands are prepended with \*AA where AA is the address of the unit. For example, the R1<cr> RS-485 command for a unit with address 00 would be \*00R1<cr>.
- 9.9.3 Digital vacuum measurement values output through communications are updated at a rate of 100 Hz or faster.

## 9.10 Detailed Command Descriptions

### 9.10.1 R1<cr>

9.10.1.1 This command is used to read the current setting for the measurement units. The units supported by the MX200 are Torr, millibar, Pascal, Torr decimal, and mTorr/Torr (mTorr is equivalent to microns). After sending this command, the returned value will indicate the current setting for the units of measurement.

Response	Description
PA	Units are set to Pascal (scientific)
TR	Units are set to Torr (scientific)
MB	Units are set to millibar (scientific)
TD	Units are set to Torr decimal (low vacuum sensors only)
MT	Units are set to mTorr/Torr (low vacuum sensors only)

9.10.1.2 Example:

```
[USER TX] R1<cr>  
[USER RX] TR<cr><lf>
```

### 9.10.2 W1XX<cr>

9.10.2.1 This command is used to change the current setting for the units of measurement. The units supported by the MX200 are Torr, millibar, Pascal, Torr decimal, and mTorr/Torr (mTorr is equivalent to microns). After sending this command, the returned value will indicate the new setting for the units of measurement.

Command	Description
W1PA	Set units to Pascal (scientific)
W1TR	Set units to Torr (scientific)
W1MB	Set units to millibar (scientific)
W1TD	Set units to Torr decimal (low vacuum sensors only)
W1MT	Set units to Torr/mTorr (low vacuum sensors only)

Response	Description
PA	Units are now set to Pascal (scientific)
TR	Units are now set to Torr (scientific)
MB	Units are now set to millibar (scientific)
TD	Units are now set to Torr decimal (low vacuum sensors only)
MT	Units are now set to mTorr/Torr (low vacuum sensors only)

9.10.2.1 Example:

```
[USER TX] W1TR<cr>  
[USER RX] TR<cr><lf>
```

### 9.10.3 S1XX<cr>

9.10.3.1 This command is used to read the vacuum reading for a single channel XX. The channel number can be from 01 to 10, and is dependent on the configuration of your MX200. After sending this command the response is the vacuum reading from channel XX in the format of ppsee (p.p \* 10<sup>see</sup>):

Command	Description
W1XX	Read vacuum reading for channel XX (01 to 10)

Response	Description
pp	Mantissa of the reading (1.0 to 9.9)
s	Sign of the exponent (0 = negative, 1 = positive)
ee	Exponent (00 to 11)

9.10.3.2 Example of reading the value from channel 1 which has a reading of  $1.0 \times 10^{-3}$ :

```
[USER TX] S101<cr>
[USER RX] 10003<cr><lf>
```

### 9.10.4 S1<cr>

9.10.4.1 This command outputs the vacuum readings for all channels connected to the MX200 in a string "01=ppsee 02=ppsee ... 10=ppsee<cr>", delimited with spaces. The format of the vacuum readings is ppsee (p.p \* 10<sup>see</sup>).

Response	Description
pp	Mantissa of the reading (1.0 to 9.9)
s	Sign of the exponent (0 = negative, 1 = positive)
ee	Exponent (00 to 11)

9.10.4.2 Example output with an MX200 configuration with channels 1, 2, and 3 connected with readings of  $1.0 \times 10^{-3}$ ,  $7.6 \times 10^2$ , and  $5.1 \times 10^{-5}$  respectively:

```
[USER TX] S1<cr>
[USER RX] 1=10003 2=76102 3=51005<cr><lf>
```

### 9.10.5 S2<cr>

9.10.5.1 This command outputs the logic firmware version. The returned value is 6 digits where each digit is a number from 0 to 9.

9.10.5.2 Example where the logic version is 160322:

```
[USER TX] S2<cr>
[USER RX] 160322<cr><lf>
```

### 9.10.6 S3<cr>

9.10.6.1 This command outputs the display firmware version. The returned value is 6 digits where each digit is a number from 0 to 9.

9.10.6.2 Example where the display version is 160322:

```
[USER TX] S3<cr>
[USER RX] 160322<cr><lf>
```

9.10.7 **S4<cr>**

9.10.7.1 This command outputs the sensor type associated with each channel in a string with the format "01=XX 02=XX ... 10=XX<cr>", delimited with spaces. XX is the sensor type and a table of possible responses is below.

Response	Sensor Type
1E	1E piezo diaphragm
1F	1F piezo diaphragm
2A	2A/Mini/NASA thermocouple
4A	4A convection
7B	7B Penning cold cathode
7EF	7E/7F/7FC/7FCS double inverted magnetron cold cathode
5A	1000 Torr capacitance diaphragm
5B	100 Torr capacitance diaphragm
5C	10 Torr capacitance diaphragm
5D	1 Torr capacitance diaphragm
5E	0.1 Torr capacitance diaphragm

9.10.8 **S5<cr>**

9.10.8.1 This command outputs the set point relay status. The return value is a string with the format "01=XX 02=XX ... 08=XX<cr>", delimited with spaces, where XX is the status of the set point relay. A table of possible responses is below.

Response	Description
ON	Relay is on
OF	Relay is off
00	No set point relay connected

9.10.9 **S6<cr>**

9.10.9.1 This command outputs information on all settings for the MX200. The response is a multi-line string with the format below. Note that this command is not meant for real time data acquisition and you should use at least 1 second delays between sending the command:

Line #	String
Line 1	Televac - The Fredericks Company, www.frederickscompany.com<cr><lf>
Line 2	MX200, Serial Number NNNNNN, Logic NNNNNN, Display NNNNNN<cr><lf>
Line 3	Channel Sensor Type<cr><lf>
Line 4	01=XX 02=XX ... 10=XX<cr><lf>
Line 5	Channels Set to Display<cr><lf>
Line 6	XX YY ... ZZ<cr><lf>
Line 7	Channel Gas Type<cr><lf>
Line 8	01=XX 02=XX ... 10=XX<cr><lf>
Line 9	Channel Resolution<cr><lf>
Line 10	01=XX 02=XX ... 10=XX<cr><lf>
Line 11	Channel Analog Format<cr><lf>
Line 12	01=X 02=X ... 10=X<cr><lf>
Line 13	Channel Analog High<cr><lf>
Line 14	01=baa 02=baa ... 10=baa<cr><lf>
Line 15	Channel Analog Low<cr><lf>
Line 16	01=baa 02=baa ... 10=baa<cr><lf>
Line 17	Set Point Relay Channel Associations<cr><lf>
Line 18	01=XX 02=XX 03=XX<cr><lf>
Line 19	Set Point Relay Low Values<cr><lf>
Line 20	01=ppsee 02=ppsee ... 08=ppsee<cr><lf>
Line 21	Set Point Relay High Values<cr><lf>
Line 22	01=ppsee 02=ppsee ... 08=ppsee<cr><lf>
Line 23	Cold Cathode Mode: YYYY<cr><lf>
Line 24	Cold Cathode Control Channels<cr><lf>
Line 25	01=XX 02=XX ... 10=XX<cr><lf>
Line 26	Calibration Values<cr><lf>
Line 27	01 1=YYY 2=YYY 3=YYY 4=YYY<cr><lf>
Line 28	02 1=YYY 2=YYY 3=YYY 4=YYY<cr><lf>
Line 29	03 1=YYY 2=YYY 3=YYY 4=YYY<cr><lf>
Line 30	04 1=YYY 2=YYY 3=YYY 4=YYY<cr><lf>
Line 31	05 1=YYY 2=YYY 3=YYY 4=YYY<cr><lf>
Line 32	06 1=YYY 2=YYY 3=YYY 4=YYY<cr><lf>
Line 33	07 1=YYY 2=YYY 3=YYY 4=YYY<cr><lf>
Line 34	08 1=YYY 2=YYY 3=YYY 4=YYY<cr><lf>
Line 35	09 1=YYY 2=YYY 3=YYY 4=YYY<cr><lf>
Line 36	10 1=YYY 2=YYY 3=YYY 4=YYY<cr><lf>

9.10.10 **RC1XX<cr>**

9.10.10.1 This command returns the first adjustment point for channel XX (01 to 10). The return value has the format Baa where B is the sign (0 for negative and 1 for positive) and aa is a numeric value for the calibration point from 00 to 99.

9.10.10.2 Example reading a calibration value of -25 from channel 1:

```
[USER TX] RC101<cr>
[USER RX] 025<cr>
```

9.10.11 **RC2XX<cr>**

9.10.11.1 This command returns the second adjustment point for channel XX (01 to 10). The return value has the format Baa where B is the sign (0 for negative and 1 for positive) and aa is a numeric value for the calibration point from 00 to 99.

9.10.11.2 Example reading a calibration value of -25 from channel 1:

```
[USER TX] RC201<cr>
[USER RX] 025<cr><lf>
```

9.10.12 **RC3XX<cr>**

9.10.12.1 This command returns the third adjustment point for channel XX (01 to 10). The return value has the format Baa where B is the sign (0 for negative and 1 for positive) and aa is a numeric value for the calibration point from 00 to 99. Note that if no third adjustment point exists for the sensor connected to the chosen channel, an error will be returned.

9.10.12.2 Example reading a calibration value of -25 from channel 1:

```
[USER TX] RC201<cr>
[USER RX] 025<cr><lf>
```

9.10.13 **RC4XX<cr>**

9.10.13.1 This command returns the fourth adjustment point for channel XX (01 to 10). The return value has the format Baa where B is the sign (0 for negative and 1 for positive) and aa is a numeric value for the calibration point from 00 to 99. Note that if no fourth adjustment point exists for the sensor connected to the chosen channel, an error will be returned.

9.10.13.2 Example reading a calibration value of -25 from channel 1:

```
[USER TX] RC201<cr>
[USER RX] 025<cr><lf>
```

9.10.14 **WC1XXBaa<cr>**

9.10.14.1 WARNING - IF THE USER ADJUSTS THE CALIBRATION VALUES ON A NIST CALIBRATED UNIT, THE NIST CALIBRATION IS VOIDED.

9.10.14.2 This command sets the first calibration point for channel XX (01 to 10) to value Baa where B is the sign (0 for negative, 1 for positive) and aa is a numeric value for the calibration point from 00 to 99. The return value is the new reading after changing the calibration value in the format PPSEE (P.P\*10<sup>see</sup>).

Response	Description
pp	Mantissa of the reading (1.0 to 9.9)
s	Sign of the exponent (0 = negative, 1 = positive)
ee	Exponent (00 to 11)

9.10.14.3 Example writing a calibration value of -25 for channel 1 with a new reading of  $1.0 \times 10^{-3}$ :

```
[USER TX] WC101025<cr>
[USER RX] 10003<cr><lf>
```

9.10.15 **WC2XXBaa<cr>**

9.10.15.1 WARNING - IF THE USER ADJUSTS THE CALIBRATION VALUES ON A NIST CALIBRATED UNIT, THE NIST CALIBRATION IS VOIDED.

9.10.15.2 This command sets the second calibration point for channel XX (01 to 10) to value Baa where B is the sign (0 for negative, 1 for positive) and aa is a numeric value for the calibration point from 00 to 99. The return value is the new reading after changing the calibration value in the format PPSEE (P.P\*10<sup>see</sup>).

Response	Description
pp	Mantissa of the reading (1.0 to 9.9)
s	Sign of the exponent (0 = negative, 1 = positive)
ee	Exponent (00 to 11)

9.10.15.3 Example writing a calibration value of -25 for channel 1 with a new reading of  $1.0 \times 10^{-3}$ :  
[USER TX] WC201025<cr>  
[USER RX] 10003<cr><lf>

9.10.16 **WC3XXBaa<cr>**

9.10.16.1 WARNING - IF THE USER ADJUSTS THE CALIBRATION VALUES ON A NIST CALIBRATED UNIT, THE NIST CALIBRATION IS VOIDED.

9.10.16.2 This command sets the third calibration point for channel XX (01 to 10) to value Baa where B is the sign (0 for negative, 1 for positive) and aa is a numeric value for the calibration point from 00 to 99. The return value is the new reading after changing the calibration value in the format PPSEE (P.P\*10<sup>see</sup>).

Response	Description
pp	Mantissa of the reading (1.0 to 9.9)
s	Sign of the exponent (0 = negative, 1 = positive)
ee	Exponent (00 to 11)

9.10.16.3 Example writing a calibration value of -25 for channel 1 with a new reading of  $1.0 \times 10^{-3}$ :  
[USER TX] WC301025<cr>  
[USER RX] 10003<cr><lf>

9.10.17 **WC4XXBaa<cr>**

9.10.17.1 WARNING - IF THE USER ADJUSTS THE CALIBRATION VALUES ON A NIST CALIBRATED UNIT, THE NIST CALIBRATION IS VOIDED.

9.10.17.2 This command sets the fourth calibration point for channel XX (01 to 10) to value Baa where B is the sign (0 for negative, 1 for positive) and aa is a numeric value for the calibration point from 00 to 99. The return value is the new reading after changing the calibration value in the format PPSEE (P.P\*10<sup>see</sup>).

Response	Description
pp	Mantissa of the reading (1.0 to 9.9)
s	Sign of the exponent (0 = negative, 1 = positive)
ee	Exponent (00 to 11)

9.10.17.3 Example writing a calibration value of -25 for channel 1 with a new reading of 1.0\*10<sup>-3</sup>:  
[USER TX] WC401025<cr>  
[USER RX] 10003<cr><lf>

9.10.18 **R2<cr>**

9.10.18.1 This command returns all channels connected to the MX200 in a string, delimited with spaces. Any channels not connected appear as "00".

9.10.18.2 Example output when channels 1, 2, and 3 are connected to the MX200:  
[USER TX] R2<cr>  
[USER RX] 01 02 03 00 00 00 00 00 00 00<cr><lf>

9.10.19 **R3XX<cr>**

9.10.19.1 This command returns the resolution setting for channel XX (01 to 10). The return value is HI for high resolution and LO for standard resolution.

9.10.19.2 Example when channel 1 is set for high resolution:  
[USER TX] R301<cr>  
[USER RX] HI<cr><lf>

9.10.20 **W3XX<cr>**

9.10.20.1 This command toggles the high/standard resolution setting for channel XX (01 to 10). The return value is the new resolution setting, where HI is high resolution and LO is standard resolution.

9.10.20.2 Example where channel 1 is set for standard resolution  
[USER TX] W301<cr>  
[USER RX] HI<cr><lf>

9.10.21 **R4<cr>**

9.10.21.1 This command returns all channels set to display on the measurement screen in a string, delimited with spaces.

9.10.21.2 Example where channels 1, 2, and 3 are set to display on the measurement screen:  
[USER TX] R4<cr>  
[USER RX] 01 02 03<cr><lf>

9.10.22 **W4XX<cr>**

9.10.22.1 This command toggles the display of channel XX (01 to 10) on the measurement screen. The return value is the new setting for the channel; ON when the channel is displaying on the measurement screen and OF when it is not.

9.10.22.2 Example when channel 1 is not currently displaying on the measurement screen:

```
[USER TX] W401<cr>
[USER RX] ON<cr><lf>
```

9.10.23 **R5XX<cr>**

9.10.23.1 This command displays the analog output format for channel XX (01 to 10). The response is FbaaBAA:

Response	Description
F	Output mode (linear = 1, logarithmic = 2)
b	Sign of the high value exponent (0 = negative, 1 = positive)
aa	High value exponent (00 to 11)
B	Sign of the low value exponent (0 = negative, 1 = positive)
AA	Low value exponent (00 to 11)

9.10.23.2 Example when the analog output for channel 1 is set to logarithmic with high value  $1.0 \times 10^3$  and low value  $1.0 \times 10^{-3}$ :

```
[USER TX] R501<cr>
[USER RX] 2103003<cr><lf>
```

#### 9.10.24 **W5XXFbaaBAA<cr>**

9.10.24.1 This command sets the analog output format and high low values for channel XX (01 to 10). If the analog output mode is set to linear, only the high value is considered and the low value is automatically calculated at 3 decades below the high value. If the analog output mode is set to linear, the response is the high value. If the analog output mode is set to logarithmic, the response is the high and low values.

Command	Description
XX	Channel number (01 to 10)
F	Output mode (linear = 1, logarithmic = 2)
b	Sign of the high value exponent (0 = negative, 1 = positive)
aa	High value exponent (00 to 11)
B	Sign of the low value exponent (0 = negative, 1 = positive)
AA	Low value exponent (00 to 11)

9.10.24.2 Response when analog output mode is set to linear:

Response	Description
F	Output mode (linear = 1, logarithmic = 2)
b	Sign of the high value exponent (0 = negative, 1 = positive)
aa	High value exponent (00 to 11)

9.10.24.3 Response when analog output mode is set to logarithmic:

Response	Description
F	Output mode (linear = 1, logarithmic = 2)
b	Sign of the high value exponent (0 = negative, 1 = positive)
aa	High value exponent (00 to 11)
B	Sign of the low value exponent (0 = negative, 1 = positive)
AA	Low value exponent (00 to 11)

9.10.24.4 Example command setting the channel 1 analog output to logarithmic with a high value of  $1.0 \cdot 10^3$  and a low value  $1.0 \cdot 10^{-3}$ :

```
[USER TX] W5012103003<cr>  
[USER RX] 2103003<cr><lf>
```

#### 9.10.25 **R6XX<cr>**

9.10.25.1 This command returns the gas setting for channel XX (01 to 10). The return value is two alphanumeric characters corresponding to the gas setting:

Response	Description
N2	Air/Nitrogen
AR	Argon
H2	Hydrogen
HE	Helium
NE	Neon
KR	Krypton
CO	Carbon Dioxide

9.10.25.2 Example command where the gas setting for channel 1 is Air/Nitrogen:

```
[USER TX] R601<cr>  
[USER RX] N2<cr><lf>
```

9.10.26 **W6XXGG<cr>**

9.10.26.1 This command changes the gas setting for channel XX (01 to 10) to GG (see table below). The return value is two alphanumeric characters corresponding to the gas setting:

GG/Response	Description
N2	Air/Nitrogen
AR	Argon
H2	Hydrogen
HE	Helium
NE	Neon
KR	Krypton
CO	Carbon Dioxide

9.10.26.2 Example command changing the gas setting for channel 1 to Argon:

```
[USER TX] W601AR<cr>  
[USER RX] AR<cr><lf>
```

9.10.27 **R7Y<cr>**

9.10.27.1 This command returns the low and high values for set point Y (1 to 8). The return value is ppseePPSEE where ppsee is the low value and PPSEE is the high value, with the format p.p\*10<sup>see</sup>.

Response	Description
pp	Mantissa of the reading (1.0 to 9.9)
s	Sign of the exponent (0 = negative, 1 = positive)
ee	Exponent (00 to 11)

9.10.27.2 Example reading set point 1 with low value 1.0\*10<sup>-3</sup> and high value 4.0\*10<sup>2</sup>:

```
[USER TX] R71<cr>  
[USER RX] 1000340102<cr><lf>
```

9.10.28 **W7YppseePPSEEZZ<cr>**

9.10.28.1 This command assigns set point relay Y (1 to 8) to channel ZZ (01 to 10) with low value ppsee and high value PPSEE where the low and high values have the format p.p\*10<sup>see</sup>. The response is ppseePPSEE where ppsee is the new set point low value and PPSEE is the new set point high value.

Response	Description
pp	Mantissa of the reading (1.0 to 9.9)
s	Sign of the exponent (0 = negative, 1 = positive)
ee	Exponent (00 to 11)

9.10.28.2 Example setting set point 1 to channel 2 with low value 1.0\*10<sup>-3</sup> and high value 4.0\*10<sup>2</sup>:

```
[USER TX] W711000340102<cr>  
[USER RX] 1000340102<cr><lf>
```

9.10.29 **R8<cr>**

9.10.29.1 This command returns the current cold cathode control mode where 1 is auto (the cold cathode is controlled by a rough vacuum sensor connected to the MX200) and 2 is manual (the cold cathode is controlled by the user).

Response	Description
1	The cold cathode control mode is set to auto
2	The cold cathode control mode is set to manual

9.10.29.2 Example where the cold cathode control mode is set to auto:  
[USER TX] R8<cr>  
[USER RX] 1<cr><lf>

9.10.30 **W8A<cr>**

9.10.30.1 This command sets the cold cathode control mode A, where 1 is auto (the cold cathode is controlled by a rough vacuum sensor connected to the MX200) and 2 is manual (the cold cathode is controlled by the user). The response is the new setting for the cold cathode control mode.

Command	Description
W81	Set the cold cathode control mode to auto
W82	Set the cold cathode control mode to manual

Response	Description
1	The cold cathode control mode is set to auto
2	The cold cathode control mode is set to manual

9.10.30.2 Example setting the cold cathode control mode to auto:  
[USER TX] W81<cr>  
[USER RX] 1<cr><lf>

9.10.31 **R9<cr>**

9.10.31.1 This command returns the cold cathode switch point which is a value from 01 to 50 mTorr (mTorr is equivalent to microns). The default switch point is 10 mTorr.

9.10.31.2 Example reading the cold cathode switch point when it is set to 10 mTorr:  
[USER TX] R9<cr>  
[USER RX] 10<cr><lf>

9.10.32 **W9BB<cr>**

9.10.32.1 This command sets the cold cathode switch point to BB, where BB is a value between 01 and 50 in mTorr (mTorr is equivalent to microns). The default value is 10 mTorr. The returned value is the new switch point value from 01 to 50.

9.10.32.2 Example changing to cold cathode switch point to 20 mTorr:  
[USER TX] W920<cr>  
[USER RX] 20<cr><lf>

### 9.10.33 R10<cr>

9.10.33.1 This command returns the status of the even and odd cold cathodes in the format CD where C is the odd cold cathodes and D is the even cold cathodes. A value of 0 indicates that the odd or even cold cathodes are off and a value of 1 indicates that the odd or even cold cathodes are on.

Response	Description
00	Odd and even cold cathodes are off
01	Odd cold cathodes are off and even cold cathodes are on
10	Odd cold cathodes are on and even cold cathodes are off
11	Odd and even cold cathodes are on

9.10.33.2 Example when the odd cold cathodes are turned on and even cold cathodes are turned off:

```
[USER TX] R10<cr>
[USER RX] 10<cr><lf>
```

### 9.10.34 W10CD<cr>

9.10.34.1 This command turns on and off cold cathodes when the cold cathode mode is set to manual. The C variable controls the odd channels and the D variable controls the even channels. Sending a 0 will turn off the odd or even channels and sending a 1 will turn on the odd or even channels. The response is the status of the odd and even cold cathodes with 0 meaning they are off and 1 meaning they are on.

Command	Description
W1000	Set the baud rate to 9600
W1001	Set the baud rate to 14400
W1010	Set the baud rate to 38400
W1011	Set the baud rate to 57600

9.10.34.2 Example turning off odd channels and turning on even channels:

```
[USER TX] W1001<cr>
[USER RX] 01<cr><lf>
```

### 9.10.35 C1TTTT<cr>

9.10.35.1 This command is used to change the baud rate of the currently selected communication mode (this applies to RS-232, RS-485, and USB). The default baud rate is 115200, note that when the baud rate is changed, once the response is received, the new baud rate will need to be used for all further communications. There are five options for the baud rate:

Command	Description
0096	Baud rate is 9600
0192	Baud rate is 19200
0384	Baud rate is 38400
0576	Baud rate is 57600 (default)
1152	Baud rate is 115200

9.10.35.2 Example changing the baud rate to 57600:

```
[USER TX] C10576<cr>
[USER RX] 0576<cr><lf>
```

### 9.10.36 C2EE<cr>

9.10.36.1 This command is used to change the RS-485 address to EE which is a decimal value from 00 to 99. Note that when this command is sent, the address of the unit will change so the prepended address on all commands needs to be changed for all further communication.

9.10.36.2 Example changing the address from 01 to 11:

```
[USER TX] *01C211<cr>
```

```
[USER RX] 11<cr><lf>
```

### 9.10.37 C4N<cr>

9.10.37.1 This command is used to change the current setting for the communications mode. After sending this command, the returned value will indicate the new setting for the communications. Note that the available options are dependent on the communications module connected to the MX200. Also note that after the response is received from this command, if the communications were changed, communications will no longer function in the previous mode.

Command	Description
C41	Set communications mode to RS-232
C42	Set communications mode to RS-485
C43	Set communications mode to USB

Response	Description
1	Communications mode is now set to RS-232
2	Communications mode is now set to RS-485
3	Communications mode is now set to USB

9.10.37.2 Example switching the communications mode to USB, note that after this command is sent, the USB connection will need to be used to communicate with the MX200:

```
[USER TX] C43<cr>
```

```
[USER RX] 3<cr><lf>
```

### 9.10.38 C1<cr>

9.10.38.1 This command outputs the baud rate TTTT of the currently selected communication mode (this applies to RS-232, RS-485, and USB). There are five options for the baud rate:

Response	Description
0096	Baud rate is 9600
0192	Baud rate is 19200
0384	Baud rate is 38400
0576	Baud rate is 57600 (default)
1152	Baud rate is 115200

9.10.39 **C2<cr>**

9.10.39.1 This command outputs the RS-485 address EE which is a decimal value from 00 to 99.

9.10.39.2 Example command where the RS-485 address is 31:

[USER TX] C2<cr>  
[USER RX] 31<cr><lf>

9.10.40 **C4<cr>**

9.10.40.1 This command outputs the digital communications setting N. There are 5 options for the communications:

Response	Description
1	Communications mode is now set to RS-232
2	Communications mode is now set to RS-485
3	Communications mode is now set to USB

9.10.41 **HM<cr>**

9.10.41.1 Return to the home screen which is the measurement screen. This is equivalent to pressing the home button from the front panel. When the unit has successfully switched to the home screen, it outputs the character 'M'.

9.10.41.2 Example command:

[USER TX] HM<cr>  
[USER RX] M<cr><lf>

9.10.42 **RLR<cr>**

9.10.42.1 This command outputs the current leak rate SXXX in mTorr/hour (mTorr is equivalent to microns) where S is the sign, and XXX is a number from 0 to 999. Note that this command will only output a valid value if the leak rate functionality is turned on through the front panel or with the WLR command.

9.10.42.2 Example command where the leak rate is 123 mTorr/hour:

[USER TX] RLR<cr>  
[USER RX] 123<cr><lf>

9.10.43 **WLRX<cr>**

9.10.43.1 This command turns the leak rate calculation for channel 1 on or off where X is 0 for off and 1 for on. After the command is sent, the unit will output the new setting, again where 0 is off and 1 is on.

9.10.43.2 Example command where the leak rate is 123 mTorr/hour:

[USER TX] WLR1<cr>  
[USER RX] 1<cr><lf>

9.10.44 **WD\_1XX<cr>**

9.10.44.1 This command restores channel XX (01 to 10) to its factory default settings for all channel settings. Note that once this command is sent the settings cannot be restored to their previous settings. Once the restore is complete, the unit will output the channel number XX (01 to 10) that was restored. The values listed below are affected:

Value	Default Factory Settings
Display	Yes (up to 8)
Gas	Nitrogen/Air (N2)
Resolution	Standard
Analog Output	Linear

9.10.45 **WD\_7XX<cr>**

9.10.45.1 This command restores set point relay XX (01 to 08) to its factory default settings. Note that once this command is sent the settings cannot be restored to their previous settings. Once the restore is complete, the unit will output the set point relay number XX (01 to 08) that was restored. The values listed below are affected:

Value	Default Factory Settings
On	Assign channel (no value)
Off	Assign channel (no value)
Channel	Select to assign channel (no channel assigned)

9.10.46 **WD\_CXX<cr>**

9.10.46.1 WARNING - IF THE USER ADJUSTS THE CALIBRATION VALUES ON A NIST CALIBRATED UNIT, THE NIST CALIBRATION IS VOIDED.

9.10.46.2 This command resets all calibration values for channel XX (01 to 10) to default factory setting values of 0. When the defaults are restored, it outputs the channel XX (01 to 10) which had the calibration values restored to defaults. Note that once this command is sent, the calibration values cannot be restored to their previous setting.

9.10.46.3 Example command resetting the calibration values for channel 1:

```
[USER TX] WD_C01<cr>  
[USER RX] 01<cr><lf>
```

9.10.47 **WD\_G<cr>**

9.10.47.1 This command resets all global setup values to default factory settings. When the defaults are restored, it outputs the character 'D'. Note that once this command is sent, the calibration values cannot be restored to their previous setting. This will also make your current digital communications non-functional if the communications are not set as shown below. The values listed below are affected:

Value	Default Factory Settings
Measurement Screen	Display the maximum number of channels
Units	Torr
Gas	Nitrogen/Air (N2) for all channels
Communications Interface	USB
Communications Baud Rate	57600
RS-485 Address	00
Cold Cathode Mode	Auto
Even Status	Off
Odd Status	Off
Cold Cathode Switch Point	1.0E-02

9.10.48 **SN<cr>**

9.10.48.1 This command outputs the 6 digit serial number of the MX200 which is in the format NNNNNN, which is a value from 000000 to 999999.

9.10.48.2 Example command:

```
[USER TX] SN<cr>  
[USER RX] 123456<cr><lf>
```

9.10.49 **PG\_LGC<cr>**

9.10.49.1 This command is used to put the logic hardware into bootloader mode. More information about the bootloader and firmware upgrades can be found in section 18. If bootloader mode is accidentally entered, power cycle the unit to exit the bootloader.

9.10.50 **PG\_DSP<cr>**

9.10.50.1 This command is used to put the display hardware into bootloader mode. More information about the bootloader and firmware upgrades can be found in section 18. If bootloader mode is accidentally entered, power cycle the unit to exit the bootloader.

## 9.11 Error Codes

### 9.11.1 **0N0000**<cr><lf>

9.11.1.1 The unit is not in the measurement screen so communication cannot be used.

### 9.11.2 **0N0001**<cr><lf>

9.11.2.1 Command error: an invalid character was sent for the command or an invalid number after the character.

### 9.11.3 **0N0002**<cr><lf>

9.11.3.1 Out of range error: an out of range value was received following a command.

### 9.11.4 **0N0003**<cr><lf>

9.11.4.1 Set point value error: an invalid or out of range number was sent after the W7 command.

### 9.11.5 **0N0004**<cr><lf>

9.11.5.1 Calibration value error: an invalid or out of range number was sent after the WC1, WC2, WC3, or WC4 commands.

### 9.11.6 **0N0005**<cr><lf>

9.11.6.1 Gas error: invalid gas characters sent after the \*OW6 command.

### 9.11.7 **0N0006**<cr><lf>

9.11.7.1 Leak rate error: channel 1 pressure is higher than 1 Torr, the leak rate is already on or off, or an unsupported module type is set to channel 1.

## 10. Analog Outputs

### 10.1 Description

- 10.1.1 Each sensor has its own 0 V DC to 10 V DC analog output. Analog outputs are configurable through the front panel or through digital communications and are unique to each sensor. Analog outputs are accessed through a 3 position screw terminal on the sensor module. They are generated by a 16-bit digital to analog converter.

### 10.2 Changing the Analog Output Function

- 10.2.1 Changing the Mode (Linear, Logarithmic, and Linear-by-Decade)

10.2.1.1 To change the analog output mode, press the home button then navigate through the following menus:

Channel Setup>Channel X>Analog Out>Mode

The options are linear, logarithmic, and linear-by-decade (sensor dependent) and the current setting is displayed at the top of the screen. Use the up and down buttons to scroll to the desired mode and press the ENT button to save it. You will see the current setting at the top of the screen change. A more detailed description of these options for each sensor can be found in Section 10.6.

- 10.2.2 Changing the High and Low Values

10.2.2.1 To change the high and low values for the analog output, press the home button then navigate through the following menus:

Channel Setup>Channel X>Analog Out>High/Low Value

The high or low value will then be displayed. Use the up and down arrows to adjust the exponent to the desired value and press the ENT button to save it. To exit without saving, press the left or home button without pressing the ENT button.

### 10.3 Notes on Logarithmic Analog Output Mode

- 10.3.1 When the analog output is set to logarithmic, both the high and low values can be modified, but there must be at least 3 decades between the high and low values. The software will automatically prevent the user from selecting a high and low value with a range less than 3 decades. Note that for sensors with only 3 decades of range, neither value can be modified.

### 10.4 Notes on Linear Analog Output Mode

- 10.4.1 The linear analog output mode is designed so that only the high value is editable. Once a high value is entered, 3 decades below that will be automatically saved as the low value. As an example, if 1.0E-4 is selected as the high value, the low value will be set to 1.0E-7. This is to maintain sufficient output resolution over the range of the 0 to 10 V DC output. Note that when a sensor has only 3 decades of range, the high value cannot be modified. Also note that the user is prevented from picking a high value that is less than 3 decades above the specified lower vacuum measurement range of the sensor.

### 10.5 Notes on Linear-by-Decade Analog Output Mode

- 10.5.1 The linear-by-decade analog output mode is designed so that neither the high or low value are editable.

## 10.6 Refresh Rate

- 10.6.1 The readings for all vacuum sensors connected to an MX200 are updated at a minimum rate of 100 Hz. The analog outputs for all vacuum sensors connected to an MX200 are updated at a minimum rate of 10 Hz.

## 10.7 Analog Output Functions

### 10.7.1 1E Piezo Diaphragm

#### 10.7.1.1 Linear Conversion

The 1E does not have settable values for the linear analog output. Therefore, the linear conversion from voltage output to pressure will always be the same:

$$\text{Voltage Output} * 10^2 = \text{Pressure}$$

Example where the voltage output is 0.500 V DC:

$$0.5 * 10^2 = 5.0 * 10^1 = 50 \text{ Torr}$$

### 10.7.2 1F Piezo Diaphragm

#### 10.7.2.1 Linear Conversion

The 1F does not have settable values for the linear analog output. Therefore, the linear conversion from voltage output to pressure will always be the same:

$$\text{Voltage Output} * 10^3 = \text{Pressure}$$

Example where the voltage output is 0.500 V DC:

$$0.5 * 10^3 = 5.0 * 10^2 = 500 \text{ Torr}$$

### 10.7.3 2A Thermocouple

#### 10.7.3.1 Linear Conversion

The 2A only provides output from  $1 \times 10^{-3}$  Torr to 1 Torr, so it does not have settable values for the linear analog output. Therefore, the linear conversion from voltage output to pressure will always be the same:

$$\text{Voltage Output} * 10^{-1} = \text{Pressure}$$

Example where the voltage output is 0.100 V DC:

$$0.100 * 10^{-1} = 0.100 / 10 = 0.010 \text{ Torr} = 1.0 * 10^{-2} \text{ Torr}$$

#### 10.7.3.2 Logarithmic Conversion

The 2A only provides output from  $1 \times 10^{-3}$  Torr to 1 Torr, so it does not have settable values for the logarithmic analog output. Therefore, the logarithmic conversion from voltage output to pressure will always be the same:

$$1.0 * 10^{0.3 * (\text{Voltage Output} - 10)} = \text{Pressure}$$

Example where the voltage output is 3.333 V DC:

$$1.0 * 10^{0.3 * (3.333 - 10)} = 1.0 * 10^{0.3 * (-6.667)} = 1.0 * 10^{-2} \text{ Torr} = 0.010 \text{ Torr}$$

## 10.7.4 4A Convection Enhanced Thermocouple

### 10.7.4.1 Linear Conversion

For the 4A linear analog output, use the high value ( $1.0 \cdot 10^H$ ) exponent H in the following equation to convert the voltage output to pressure:

$$\text{Voltage Output} * 10^{(H-1)} = \text{Pressure}$$

Example linear output where the voltage output is 0.010 V DC and the high value is  $1.0 \cdot 10^0$ . Take the high value exponent 0 for H and use it in the equation above:

$$0.010 * 10^{(0-1)} = 0.010 * 10^{-1} = 0.010 / 10 = 0.001 \text{ Torr} = 1 * 10^{-3} \text{ Torr}$$

### 10.7.4.2 Logarithmic Conversion

The 4A logarithmic analog output has settable high and low values, so they must be taken into consideration when converting the voltage output to pressure:

$$\text{High Value} = 1.0 * 10^H$$

$$\text{Low Value} = 1.0 * 10^L$$

$$C_1 = (1/(L-H)) * (-10)$$

$$C_2 = (1/(L-H)) * 10 * L$$

$$1.0 * 10^{(1/C_1) * (\text{Voltage Output} - C_2)} = \text{Pressure}$$

Example logarithmic output where the voltage output is 1.666 V DC, the high value is  $1.0 \cdot 10^3$ , and the low value is  $1.0 \cdot 10^{-3}$ :

$$\text{High Value} = 1.0 * 10^3$$

$$\text{Low Value} = 1.0 * 10^{-3}$$

$$C_1 = (1/(-3-3)) * (-10) = 1.667$$

$$C_2 = (1/(-3-3)) * 10 * (-3) = 5$$

$$1.0 * 10^{(1/1.667) * (1.666 - 5)} = 1.0 * 10^{0.6 * (-3.333)} = 1.0 * 10^{-2} \text{ Torr} = 0.010 \text{ Torr}$$

### 10.7.4.3 Linear-by-Decade (L-D) Conversion

The 4A linear-by-decade output has a range of  $1 \cdot 10^{-3}$  Torr to 1000 Torr. Neither the high or low values are settable for this analog output, so the linear-by-decade conversion from voltage output to pressure will always be the same:

$$\text{Voltage Output in V DC} = A.BCD$$

$$\text{Pressure in Torr} = 0.BCD * 10^{(A-6)}$$

Example linear-by-decade voltage output to pressure conversions:

$$\text{Voltage Output in V DC} = 5.900 \text{ V DC}$$

$$\text{Pressure in Torr} = 0.900 * 10^{(5-6)} = 0.900 * 10^{-1} = 9.0 * 10^{-2} \text{ Torr}$$

$$\text{Voltage Output in V DC} = 9.300 \text{ V DC}$$

$$\text{Pressure in Torr} = 0.300 * 10^{(9-6)} = 0.300 * 10^3 = 3.0 * 10^2 \text{ Torr}$$

## 10.7.5 7B Penning Cold Cathode

### 10.7.5.1 Linear Conversion

For the 7B linear analog output, use the high value ( $1.0 \times 10^H$ ) exponent H in the following equation to convert the voltage output to pressure:

$$\text{Voltage Output} * 10^{(H-1)} = \text{Pressure}$$

Example linear output where the voltage output is 0.500 V DC and the high value is  $1.0 \times 10^{-4}$ . Take the high value exponent 0 for H and use it in the equation above:

$$0.500 * 10^{(-4-1)} = 0.5 * 10^{-5} = 5.0 * 10^{-6} \text{ Torr}$$

### 10.7.5.2 Logarithmic Conversion

The 7B logarithmic output has settable high and low values, so they must be taken into consideration when converting the voltage output to pressure:

$$\text{High Value} = 1.0 * 10^H$$

$$\text{Low Value} = 1.0 * 10^L$$

$$C_1 = (1/(L-H)) * (-10)$$

$$C_2 = (1/(L-H)) * 10 * L$$

$$1.0 * 10^{(1/C_1) * (\text{Voltage Output} - C_2)} = \text{Pressure}$$

Example logarithmic output where the voltage output is 7.500 V DC, the high value is  $1.0 \times 10^{-3}$ , and the low value is  $1.0 \times 10^{-7}$ :

$$\text{High Value} = 1.0 * 10^{-3}$$

$$\text{Low Value} = 1.0 * 10^{-7}$$

$$C_1 = (1/(-7-(-3))) * (-10) = 2.5$$

$$C_2 = (1/(-7-(-3))) * 10 * (-7) = 17.5$$

$$1.0 * 10^{(1/2.5) * (7.500 - 17.5)} = 1.0 * 10^{0.4 * (-10)} = 1.0 * 10^{-4} \text{ Torr}$$

### 10.7.5.3 Linear-by-Decade (L-D) Conversion

The 7B linear-by-decade output has a range of  $1 \times 10^{-7}$  Torr to  $1 \times 10^{-3}$  Torr. Neither the high or low values are settable for this analog output, so the linear-by-decade conversion from voltage output to pressure will always be the same:

$$\text{Voltage Output in V DC} = A.BCD$$

$$A.BCD/2 = E.FGH$$

$$\text{Pressure in Torr} = 0.FGH * 10^{(E-7)}$$

Example linear-by-decade voltage output to pressure conversions:

$$\text{Voltage Output in V DC} = 5.800 \text{ V DC}$$

$$5.800/2 = 2.900$$

$$\text{Pressure in Torr} = 0.900 * 10^{(2-7)} = 0.900 * 10^{-5} = 9.0 * 10^{-6} \text{ Torr}$$

$$\text{Voltage Output in V DC} = 9.200 \text{ V DC}$$

$$9.200/2 = 4.600$$

$$\text{Pressure in Torr} = 0.600 * 10^{(4-7)} = 0.600 * 10^{-3} = 6.0 * 10^{-4} \text{ Torr}$$

## 10.7.6 7E, 7F, 7FC, 7FCS Double Inverted Magnetron Cold Cathodes

### 10.7.6.1 Linear Conversion

For the 7E, 7F, 7FC, and 7FCS linear analog outputs, use the high value ( $1.0 \cdot 10^H$ ) exponent H in the following equation to convert the voltage output to pressure:

$$\text{Voltage Output} * 10^{(H-1)} = \text{Pressure}$$

Example linear output where the voltage output is 0.500 V DC and the high value is  $1.0 \cdot 10^{-4}$ . Take the high value exponent 0 for H and use it in the equation above:

$$0.500 * 10^{(-4-1)} = 0.5 * 10^{-5} = 5.0 * 10^{-6} \text{ Torr}$$

### 10.7.6.2 Logarithmic Conversion

The 7E, 7F, 7FC, and 7FCS logarithmic outputs have settable high and low values, so they must be taken into consideration when converting the voltage output to pressure:

$$\text{High Value} = 1.0 * 10^H$$

$$\text{Low Value} = 1.0 * 10^L$$

$$C_1 = (1/(L-H)) * (-10)$$

$$C_2 = (1/(L-H)) * 10 * L$$

$$1.0 * 10^{(1/C_1) * (\text{Voltage Output} - C_2)} = \text{Pressure}$$

Example logarithmic output where the voltage output is 3.333 V DC, the high value is  $1.0 \cdot 10^{-11}$ , and the low value is  $1.0 \cdot 10^{-2}$ :

$$\text{High Value} = 1.0 * 10^{-2}$$

$$\text{Low Value} = 1.0 * 10^{-11}$$

$$C_1 = (1/(-11-(-2))) * (-10) = 1.111$$

$$C_2 = (1/(-11-(-2))) * 10 * (-11) = 12.222$$

$$1.0 * 10^{(1/1.111) * (3.333 - 12.222)} = 1.0 * 10^{0.9 * (-8.888)} = 1.0 * 10^{-8} \text{ Torr}$$

### 10.7.6.3 Linear-by-Decade (L-D) Conversion for the 7F, 7FC, and 7FCS

The linear-by-decade output for the 7F, 7FC, and 7FCS has a range of  $1 \cdot 10^{-11}$  Torr to  $1 \cdot 10^{-2}$  Torr. Neither the high or low values are settable for this analog output, so the linear-by-decade conversion from voltage output to pressure will always be the same:

$$\text{Voltage Output in V DC} = A.BCD$$

$$\text{Pressure in Torr} = 0.BCD * 10^{(A-10)}$$

Example linear-by-decade voltage output to pressure conversions:

$$\text{Voltage Output in V DC} = 5.900 \text{ V DC}$$

$$\text{Pressure in Torr} = 0.900 * 10^{(5-10)} = 0.900 * 10^{-5} = 9.0 * 10^{-6} \text{ Torr}$$

$$\text{Voltage Output in V DC} = 1.300 \text{ V DC}$$

$$\text{Pressure in Torr} = 0.300 * 10^{(1-10)} = 0.300 * 10^{-9} = 3.0 * 10^{-10} \text{ Torr}$$

#### 10.7.6.4 Linear-by-Decade (L-D 7E) Conversion for the 7E

The linear-by-decade output for the 7F, 7FC, and 7FCS has a range of  $1 \times 10^{-8}$  Torr to  $1 \times 10^{-2}$  Torr. Neither the high or low values are settable for this analog output, so the linear-by-decade conversion from voltage output to pressure will always be the same:

$$\begin{aligned} \text{Voltage Output in V DC} &= A.BCD \\ \text{Pressure in Torr} &= 0.BCD * 10^{(A-11)} \end{aligned}$$

Example linear-by-decade outputs where the voltage output is 5.900 V DC:

$$\begin{aligned} \text{Voltage Output in V DC} &= 5.900 \text{ V DC} \\ \text{Pressure in Torr} &= 0.900 * 10^{(5-11)} = 0.900 * 10^{-6} = 9.0 * 10^{-7} \text{ Torr} \end{aligned}$$

$$\begin{aligned} \text{Voltage Output in V DC} &= 9.300 \text{ V DC} \\ \text{Pressure in Torr} &= 0.300 * 10^{(9-11)} = 0.300 * 10^{-2} = 3.0 * 10^{-3} \text{ Torr} \end{aligned}$$

#### 10.7.7 5A, 5B, 5C, 5D Capacitance Diaphragm Gauges

##### 10.7.7.1 Linear Conversion

The 5A, 5B, 5C, and 5D do not have settable values for the linear analog output. Therefore, the linear conversion from voltage output to pressure will always be the same:

$$( \text{Voltage Output} * \text{Full Scale} ) / 10 = \text{Pressure}$$

Example where the voltage output is 0.100 V DC from a 100 Torr full scale CDG:

$$(0.100 * 100) / 10 = 10 / 10 = 1 \text{ Torr}$$

## 11. Set Points

### 11.1 Description

11.1.1 Set points are SPDT Form C dry contact relays rated for 8 A at 250 V AC or 5 A at 30 V DC. There are four set points per module and the MX200 can control up to two set point modules. The relay electrical connections are made through three position screw terminals on the set point relay module. The three relay connections are NC (normally closed), NO (normally open), and C (common). Each set point can be assigned to a channel and multiple set points can be assigned to the same channel.

### 11.2 Set Point Channel Association

11.2.1 To change the set point channel association, press the home button then navigate through the following menus:

Set Points>Set Point X>Channel Association

A list of all assignable channels is then displayed. Press ENT on a channel to assign it to the currently selected set point. Note that when the channel is changed, any previously saved values for low and high are replaced with default values based on the sensor type connected to the newly assigned channel.

### 11.3 Set Point On and Off Values

11.3.1 The set point on pressure must always be a lower pressure than the set point off pressure. As a system pumps down and reaches the set point on pressure value, the relay associated with that set point is energized (switches from NC to NO). As the system leaks up toward atmosphere, the relay will de-energize (switch from NO to NC) once it reaches the set point off vacuum value. To adjust set point values, press the home button then navigate through the following menus:

Set Points>Set Point X>On/Off

You can then adjust the on/off values using the left and right arrow keys to select a digit and then using the up and down arrows to adjust the specific digit. Once the desired set point value is displayed, press the ENT button to save it. To exit without saving, press the home button.

## 12. Calibration

### 12.1 READ THIS FIRST - WARNING

- 12.1.1 IF THE USER ADJUSTS THE CALIBRATION VALUES ON A NIST CALIBRATED UNIT, THE NIST CALIBRATION IS VOIDED.

### 12.2 Description

- 12.2.1 Each sensor includes multiple calibration points which are unique to the sensor type and set to a value between -99 and 99. These calibration values can be set by pressing the home button then navigating through the following menus:

Calibration>Channel X>Select Calibration Point

The output from the selected channel is displayed at the top of the screen with the calibration factor below it. Use the up and down arrows to adjust the calibration factor and observe the change in the output above. Once the desired output value is reached, press ENT to save. To exit the screen without saving the calibration value, press the left or home button.

Many sensors are also gas dependent so a variety of correction factors are implemented in the MX200 software for specific gases. The gas must be selected through the front panel or through digital communications. See Section 12.2 for more information about gases.

### 12.3 NIST and Standard Calibration

- 12.3.1 Standard calibration is performed on all MX200s before they are shipped from our facility. This is an electrical verification test and is not completed under vacuum.
- 12.3.2 Televac provides NIST (National Institute of Standards and Technology) calibration for all of our sensors at an additional cost based on the number of MX200 channels being NIST calibrated. Note that for NIST calibration, the user must provide all sensors and cables with the MX200 (unless new sensors and cables are purchased). When a unit is NIST calibrated, Televac provides all incoming and outgoing readings for NIST calibrated channels with a certificate. The calibration is completed under vacuum.

### 12.4 Calibration Points

Sensor	Calibration Points (Torr)
1E	1, 760
1F	760, 7600
2A	0, 1
4A	0, 1, 70, 760
7B	1E-6, 1E-5, 1E-4, 1E-3
7E, 7F, 7FC, 7FCS	1E-5, 1E-3
5A, 5B, 5C, 5D, 5E, 5F	0, Full Scale

### 12.5 Calibration Frequency

- 12.5.1 Calibration frequency requirements vary significantly depending on the processes to which sensors are exposed and quality requirements for individual users. Televac suggests a minimum interval of 1 year between calibrations.

## 12.6 Gases

- 12.6.1 **WARNING - SELECTING AN INCORRECT GAS CAN LEAD TO DANGEROUS WORKING CONDITIONS.**  
In some situations, selecting an incorrect gas can cause the MX200 to read a lower pressure than the chamber's true pressure. In these cases the inside of the chamber can reach pressures well above atmosphere when the MX200 reads atmosphere.
- 12.6.2 Most sensors operated by the MX200 are gas dependent. To compensate for gases other than Nitrogen/Air, the MX200 is programmed with gas conversion functions for a variety of gases. These conversions are implemented for the 2A (including mini versions), 4A, 7B, and 7E/F/FC/FCS. The gas types are Nitrogen/Air, Argon, Hydrogen, Helium, Neon, Krypton, and Carbon Dioxide.

Gas	Abbreviation
Air/Nitrogen	N2
Argon	AR
Hydrogen	H2
Helium	HE
Neon	NE
Krypton	KR
Carbon Dioxide	CO

## 12.7 Gas Selection

- 12.7.1 To change the gas type for a channel, press the home button then navigate through the following menus:

Global Setup>Gas>Channel X

The current gas setting for the selected channel is displayed at the top of the screen. Use the up and down arrows to select a new gas and press the ENT button to save it. The new gas setting will now be displayed at the top of the screen. Press the left or home button to exit. Press the left or home button without first pressing the ENT button to exit the gas selection menu without saving a new setting.

Another way to select the gas for a particular channel is to press the home button then navigate into:

Channel Setup>Channel X>Gas

Again the current gas setting for the selected channel is displayed at the top of the screen. Use the up and down arrows to select a new gas and press the ENT button to save it. The new gas setting will now be displayed at the top of the screen. Press the left or home button to exit. Press the left or home button without first pressing the ENT button to exit the gas selection menu without saving a new setting.

## 13. Modules, Sensors, and Cables

### 13.1 Module Description

13.1.1 Modules control 1 or 2 vacuum sensors and are connected to the back of the MX200. Modules can be added, removed, and replaced so long as channel assignments between different modules do not conflict. All calibration adjustments are digital and accessed through the front panel or digital communications. See Section 12 on calibration for additional information. Each module has a 0 V DC to 10 V DC analog output for each sensor connected to it. These outputs are accessed through three position screw terminals on the module.

Note: Module designs will remain the same as in the MM200 with the exception of the power supply module and the communications module.

### 13.2 Removing and Replacing Modules

13.2.1 Modules should only be removed or replaced by a trained technician familiar with the MX200. Be sure to power down the MX200 and disconnect power before removing any modules or performing any service.

Modules are secured by two #6-20 Phillips head screws. Once the screws are removed, the module slides out for removal, service, or replacement. After reconnecting the module to the MX200, be sure to replace the two screws to prevent accidental removal of the module.

### 13.3 Sensor Description

13.3.1 Sensors are the element in direct contact with vacuum and they are connected to MX200 modules with a cable. The module generates the signal for the sensor and reads the output from it. The analog outputs from the sensors are converted by a 16-bit analog to digital converter. The MX200 will support all sensor designs listed below.

### 13.4 1E

13.4.1 Description

<b>Module Part Number</b>	2-6200-220
<b>Sensor Description</b>	Piezo Diaphragm
<b>Gas Dependent</b>	No
<b>Module Interface</b>	Amphenol 4 Pin
<b>Sensor Interface</b>	Octal Connector
<b>Sensor Range (Torr)</b>	1 to 1000
<b>Calibration Points (Torr)</b>	1, 760
<b>Sensors Controlled by Module</b>	2
<b>MX200 Slots Used</b>	1
<b>Maximum Modules in Single MX200</b>	5

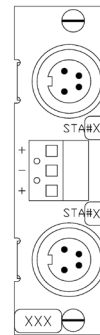

13.4.2 Sensor Part Numbers

Description	Part Number
1/8" NPT Brass	2-2106-001
NW16 (DN16 ISO-KF) Stainless Steel	2-2107-030
NW25 (DN25 ISO-KF) Stainless Steel	2-2107-031
NW40 (DN40 ISO-KF) Stainless Steel	2-2107-032
2.75" CF (DN40 ISO-CF-F) Stainless Steel	2-2107-052

### 13.4.3 Cable Part Numbers

Length	Part Number
3 m (10 feet)	2-9819-010
6 m (20 feet)	2-9819-020
11 m (35 feet)	2-9819-035
15 m (50 feet)	2-9819-050
Non-standard Lengths	6-9800-00

## 13.5 1F

### 13.5.1 Description

<b>Module Part Number</b>	2-6200-244
<b>Sensor Description</b>	Piezo Diaphragm
<b>Gas Dependent</b>	No
<b>Module Interface</b>	Amphenol 4 Pin
<b>Sensor Interface</b>	Octal Connector
<b>Sensor Range (Torr)</b>	760 to 7600
<b>Calibration Points (Torr)</b>	760, 7600
<b>Sensors Controlled by Module</b>	2
<b>MX200 Slots Used</b>	1
<b>Maximum Modules in Single MX200</b>	5

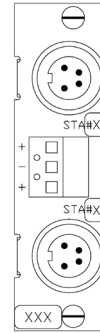

### 13.5.2 Sensor Part Numbers

Description	Part Number
1/8" NPT Brass	2-2108-001
NW16 (DN16 ISO-KF) Stainless Steel	2-2109-030
NW25 (DN25 ISO-KF) Stainless Steel	2-2109-031
NW40 (DN40 ISO-KF) Stainless Steel	2-2109-032
2.75" CF (DN40 ISO-CF-F) Stainless Steel	2-2109-052

### 13.5.3 Cable Part Numbers

Length	Part Number
3 m (10 feet)	2-9819-010
6 m (20 feet)	2-9819-020
11 m (35 feet)	2-9819-035
15 m (50 feet)	2-9819-050
Non-standard Lengths	6-9800-00

## 13.6 2A

### 13.6.1 Description

<b>Module Part Number</b>	2-6200-186
<b>Sensor Description</b>	Thermocouple
<b>Gas Dependent</b>	Yes
<b>Module Interface</b>	Amphenol 4 Pin
<b>Sensor Interface</b>	Octal Connector
<b>Sensor Range (Torr)</b>	1.0E-3 to 1
<b>Calibration Points (Torr)</b>	0, 1
<b>Sensors Controlled by Module</b>	2
<b>MX200 Slots Used</b>	1
<b>Maximum Modules in Single MX200</b>	5

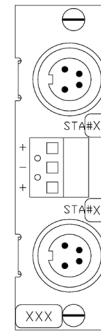

### 13.6.2 Sensor Part Numbers

Description	Part Number
1/8" NPT Nickel-plated Brass	2-2100-10
1/8" NPT Stainless Steel	2-2126-001
NW16 (DN16 ISO-KF) Stainless Steel	2-2126-030
NW25 (DN25 ISO-KF) Stainless Steel	2-2126-031
8-VCO Male Stainless Steel	2-2126-040
8-VCO Female Stainless Steel	2-2126-041
8-VCR Male Stainless Steel	2-2126-042
8-VCR Female Stainless Steel	2-2126-043
4-VCR Male Stainless Steel	2-2126-044
4-VCR Female Stainless Steel	2-2126-045
1.33" CF (DN16 ISO-CF-F) Stainless Steel	2-2126-050
2.75" CF (DN40 ISO-CF-F) Stainless Steel	2-2126-052

### 13.6.3 Cable Part Numbers

Length	Part Number
3 m (10 feet)	2-9800-52
6 m (20 feet)	2-9800-53
11 m (35 feet)	2-9800-55
15 m (50 feet)	2-9800-56
Non-standard Lengths	6-9800-00

## 13.7 4A

### 13.7.1 Description

<b>Module Part Number</b>	2-6200-215
<b>Sensor Description</b>	Convection Enhanced Thermocouple
<b>Gas Dependent</b>	Yes
<b>Module Interface</b>	Amphenol 4 Pin
<b>Sensor Interface</b>	Octal Connector
<b>Sensor Range (Torr)</b>	1.0E-3 to 1000
<b>Calibration Points (Torr)</b>	0, 1, 10, 100, 760
<b>Sensors Controlled by Module</b>	2
<b>MX200 Slots Used</b>	1
<b>Maximum Modules in Single MX200</b>	5

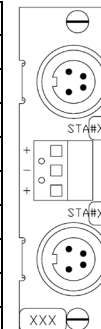

### 13.7.2 Sensor Part Numbers

Description	Part Number
1/8" NPT Nickel-plated Brass	2-2119-001
1/8" NPT Stainless Steel	2-2120-001
NW16 (DN16 ISO-KF) Stainless Steel	2-2120-030
NW25 (DN25 ISO-KF) Stainless Steel	2-2120-031
8-VCO Male Stainless Steel	2-2120-040
8-VCO Female Stainless Steel	2-2120-041
8-VCR Male Stainless Steel	2-2120-042
8-VCR Female Stainless Steel	2-2120-043
4-VCR Male Stainless Steel	2-2120-044
4-VCR Female Stainless Steel	2-2120-045
1.33" CF (DN16 ISO-CF-F) Stainless Steel	2-2120-050
2.75" CF (DN40 ISO-CF-F) Stainless Steel	2-2120-052

### 13.7.3 Cable Part Numbers

Length	Part Number
3 m (10 feet)	2-9819-010
6 m (20 feet)	2-9819-020
11 m (35 feet)	2-9819-035
15 m (50 feet)	2-9819-050
Non-standard Lengths	6-9800-00

## 13.8 7B

### 13.8.1 Description

<b>Module Part Number</b>	2-6200-227
<b>Sensor Description</b>	Penning Magnetron Cold Cathode
<b>Gas Dependent</b>	Yes
<b>Module Interface</b>	MHV
<b>Sensor Interface</b>	MHV
<b>Sensor Range (Torr)</b>	1.0E-7 to 1.0E-3
<b>Calibration Points (Torr)</b>	1E-6, 1E-5, 1E-4, 1E-3
<b>Sensors Controlled by Module</b>	1
<b>MX200 Slots Used</b>	1.5
<b>Maximum Modules in Single MX200</b>	3

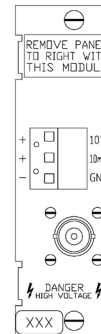

### 13.8.2 Sensor Part Numbers

Description	Part Number
3/4" NPT Brass	2-2100-263
3/4" Straight Brass	2-2100-264
1" Straight Brass	2-2100-265
1 1/4" Straight Brass	2-2100-266
1" Straight Stainless Steel	2-2100-267
NW25 (DN25 ISO-KF) Stainless Steel	2-2100-272

### 13.8.3 Cable Part Numbers

Length	Part Number
3 m (10 feet)	2-9800-09
6 m (20 feet)	2-9800-41
11 m (35 feet)	2-9800-42
15 m (50 feet)	2-9800-43
Non-standard Lengths	6-9800-00

## 13.9 7E

### 13.9.1 Description

<b>Module Part Number</b>	2-6200-285
<b>Sensor Description</b>	Double Inverted Magnetron Cold Cathode
<b>Gas Dependent</b>	Yes
<b>Module Interface</b>	SHV5
<b>Sensor Interface</b>	SHV5
<b>Sensor Range (Torr)</b>	1.0E-8 to 1.0E-2
<b>Calibration Points (Torr)</b>	1E-5, 1E-3
<b>Sensors Controlled by Module</b>	1
<b>MX200 Slots Used</b>	1
<b>Maximum Modules in Single MX200</b>	5

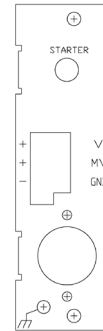

### 13.9.2 Sensor Part Numbers

Description	Part Number
1" Straight Stainless Steel	2-2142-013
NW16 (DN16 ISO-KF)	2-2142-030
NW25 (DN25 ISO-KF)	2-2142-031
NW40 (DN40 ISO-KF)	2-2142-032
2.75" CF (DN40 ISO-CF-F)	2-2142-052

### 13.9.3 Cable Part Numbers

Length	Part Number
3 m (10 feet)	2-9841-010
6 m (20 feet)	2-9841-020
11 m (35 feet)	2-9841-035
15 m (50 feet)	2-9841-050
Non-standard Lengths	6-9800-00

## 13.10 7F

### 13.10.1 Description

<b>Module Part Number</b>	2-6200-285
<b>Sensor Description</b>	Double Inverted Magnetron Cold Cathode
<b>Gas Dependent</b>	Yes
<b>Module Interface</b>	SHV5
<b>Sensor Interface</b>	SHV5
<b>Sensor Range (Torr)</b>	1.0E-11 to 1.0E-2
<b>Calibration Points (Torr)</b>	1E-5, 1E-3
<b>Sensors Controlled by Module</b>	1
<b>MX200 Slots Used</b>	1
<b>Maximum Modules in Single MX200</b>	5

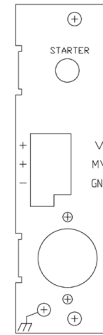

### 13.10.2 Sensor Part Numbers

Description	Part Number
2.75" CF (DN40 ISO-CF-F)	2-2144-052

### 13.10.3 Cable Part Numbers

Length	Part Number
3 m (10 feet)	2-9841-010
6 m (20 feet)	2-9841-020
11 m (35 feet)	2-9841-035
15 m (50 feet)	2-9841-050
Non-standard Lengths	6-9800-00

## 13.11 7FC

### 13.11.1 Description

<b>Module Part Number</b>	2-6200-285
<b>Sensor Description</b>	Double Inverted Magnetron Cold Cathode
<b>Gas Dependent</b>	Yes
<b>Module Interface</b>	SHV5
<b>Sensor Interface</b>	SHV5
<b>Sensor Range (Torr)</b>	1.0E-11 to 1.0E-2
<b>Calibration Points (Torr)</b>	1E-5, 1E-3
<b>Sensors Controlled by Module</b>	1
<b>MX200 Slots Used</b>	1
<b>Maximum Modules in Single MX200</b>	5

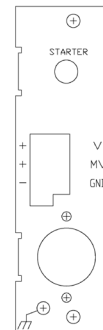

### 13.11.2 Sensor Part Numbers

Description	Part Number
2.75" CF (DN40 ISO-CF-F)	2-2146-052

### 13.11.3 Cable Part Numbers

Length	Part Number
3 m (10 feet)	2-9841-010
6 m (20 feet)	2-9841-020
11 m (35 feet)	2-9841-035
15 m (50 feet)	2-9841-050
Non-standard Lengths	6-9800-00

## 13.12 7FCS

### 13.12.1 Description

<b>Module Part Number</b>	2-6200-285
<b>Sensor Description</b>	Double Inverted Magnetron Cold Cathode Quick Start
<b>Gas Dependent</b>	Yes
<b>Module Interface</b>	SHV5
<b>Sensor Interface</b>	SHV5
<b>Sensor Range (Torr)</b>	1.0E-11 to 1.0E-2
<b>Calibration Points (Torr)</b>	1E-5, 1E-3
<b>Sensors Controlled by Module</b>	1
<b>MX200 Slots Used</b>	1
<b>Maximum Modules in Single MX200</b>	5

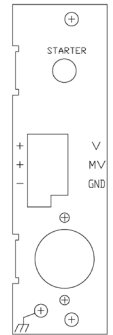

### 13.12.2 Sensor Part Numbers

Description	Part Number
2.75" CF (DN40 ISO-CF-F)	2-2146-053

### 13.12.3 Cable Part Numbers

Length	Part Number
3 m (10 feet)	2-9841-010
6 m (20 feet)	2-9841-020
11 m (35 feet)	2-9841-035
15 m (50 feet)	2-9841-050
Non-standard Lengths	6-9800-00

### 13.12.4 Ignition Cable Part Numbers for Quick Start Capability

Length	Part Number
3 m (10 feet)	2-9837-010
6 m (20 feet)	2-9837-020
11 m (35 feet)	2-9837-035
15 m (50 feet)	2-9837-050
Non-standard Lengths	6-9800-00

### 13.13 5A

<b>Module Part Number</b>	2-6200-252
<b>Sensor Description</b>	Capacitance Diaphragm
<b>Gas Dependent</b>	No
<b>Module Interface</b>	Amphenol 5 Pin
<b>Sensor Interface</b>	Sensor dependent
<b>Sensor Range (Torr)</b>	1E-1 to 1000
<b>Calibration Points (Torr)</b>	0, Full Scale
<b>Sensors Controlled by Module</b>	1
<b>MX200 Slots Used</b>	1
<b>Maximum Modules in Single MX200</b>	5

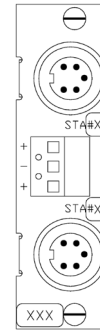

### 13.14 5B

<b>Module Part Number</b>	2-6200-252
<b>Sensor Description</b>	Capacitance Diaphragm
<b>Gas Dependent</b>	No
<b>Module Interface</b>	Amphenol 5 Pin
<b>Sensor Interface</b>	Sensor dependent
<b>Sensor Range (Torr)</b>	1E-2 to 100
<b>Calibration Points (Torr)</b>	0, Full Scale
<b>Sensors Controlled by Module</b>	1
<b>MX200 Slots Used</b>	1
<b>Maximum Modules in Single MX200</b>	5

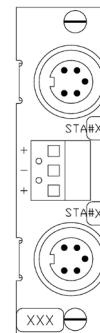

### 13.15 5C

<b>Module Part Number</b>	2-6200-252
<b>Sensor Description</b>	Capacitance Diaphragm
<b>Gas Dependent</b>	No
<b>Module Interface</b>	Amphenol 5 Pin
<b>Sensor Interface</b>	Sensor dependent
<b>Sensor Range (Torr)</b>	1E-3 to 10
<b>Calibration Points (Torr)</b>	0, Full Scale
<b>Sensors Controlled by Module</b>	1
<b>MX200 Slots Used</b>	1
<b>Maximum Modules in Single MX200</b>	5

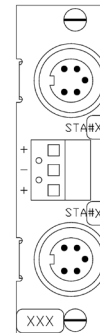

### 13.16 5D

<b>Module Part Number</b>	2-6200-252
<b>Sensor Description</b>	Capacitance Diaphragm
<b>Gas Dependent</b>	No
<b>Module Interface</b>	Amphenol 5 Pin
<b>Sensor Interface</b>	Sensor dependent
<b>Sensor Range (Torr)</b>	1E-4 to 1
<b>Calibration Points (Torr)</b>	0, Full Scale
<b>Sensors Controlled by Module</b>	1
<b>MX200 Slots Used</b>	1
<b>Maximum Modules in Single MX200</b>	5

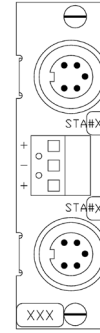

### 13.17 5E

<b>Module Part Number</b>	2-6200-252
<b>Sensor Description</b>	Capacitance Diaphragm
<b>Gas Dependent</b>	No
<b>Module Interface</b>	Amphenol 5 Pin
<b>Sensor Interface</b>	Sensor dependent
<b>Sensor Range (Torr)</b>	1E-5 to 0.1
<b>Calibration Points (Torr)</b>	0, Full Scale
<b>Sensors Controlled by Module</b>	1
<b>MX200 Slots Used</b>	1
<b>Maximum Modules in Single MX200</b>	5



### 13.18 5F

<b>Module Part Number</b>	2-6200-252
<b>Sensor Description</b>	Capacitance Diaphragm
<b>Gas Dependent</b>	No
<b>Module Interface</b>	Amphenol 5 Pin
<b>Sensor Interface</b>	Sensor dependent
<b>Sensor Range (Torr)</b>	Custom
<b>Calibration Points (Torr)</b>	0, Full Scale
<b>Sensors Controlled by Module</b>	1
<b>MX200 Slots Used</b>	1
<b>Maximum Modules in Single MX200</b>	5

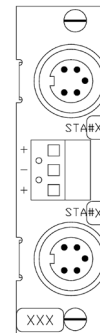

### 13.19 Set Point Relay Module

13.19.1 The set point relay module includes 4 relays for use with set points. The electrical connections to the relays are accessed through (4) 3 position screw terminals on the module. This module uses 1 slot in the MX200 and a maximum of 2 modules can be used in a single MX200, providing up to 8 set point relays. For additional information on set points, see Section 11.0.

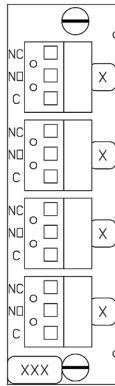

### 13.20 Power Supply Module

13.20.1 The power supply module includes a power switch, a connection for 110 V AC/220 V AC power, and a voltage selection switch. Be sure that the voltage selection switch is in the correct position for your system before turning on the unit.

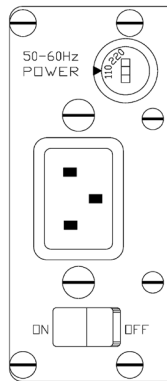

### 13.21 RS-232/RS-485/USB Communications Module and Lockout Switch

13.21.1 The RS-232/RS-485/USB communications module includes a D-sub 9 pin female connection for RS-232, a 3 position screw terminal connection for RS-485, and a USB B type receptacle for USB. There is also a lockout switch which is described in more detail below and a hard reset button described in more detail in Section 16.

The communications module must be connected to slot 7. Additionally, the standard MX200 will include the communications module, it is not an optional component.

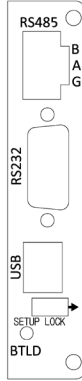

#### 13.21.2 USB Cable

Length	Part Number
1.8 m (6 feet)	1-2400-005

13.21.3 The setup lock switch prevents changes to any of the settings through the front panel when the switch is set in the direction of the arrow. Note that digital communications (such as USB, RS-232, or RS-485) can still be used to change the unit settings.

### 13.22 Additional Notes on Modules, Sensors, and Cables

13.22.1 Radiation resistant and high temperature cables are available for many sensors. Refer to specific sensor data sheets for more information.

13.22.2 The MX200 does not currently control any hot ion sensors.

## 14. High Vacuum Measurement

### 14.1 Description

- 14.1.1 Cold cathodes provide high vacuum measurement and these sensors cannot remain energized at pressures above  $1.0E-2$  Torr. They therefore must be switched on and off manually or by using another Televac low vacuum sensor. If the cold cathode is energized at pressures above  $1.0E-3$  Torr for extended periods of time, particularly in environments where oxygen is present, rapid degradation of the sensor will occur due to contamination from sputtering of the cathode.

### 14.2 Changing Between Auto and Manual Modes

- 14.2.1 To change the cold cathodes between auto and manual modes, press the home button then navigate through the following menus:

Global Setup>Cold Cathode

Scroll to the "Mode: Auto/Manual" line and press the ENT button to switch between the two options. This can also be accomplished through digital communications, see Section 9 for more information.

### 14.3 Manual High Vacuum Switching

- 14.3.1 Manual high vacuum switching is accomplished by pressing the home button then navigating through the following menus:

Global Setup>Cold Cathode

Scroll to the "Even Status: On/Off" or "Odd Status: On/Off" line and press the ENT button to toggle the status of the selected channels. Note that if the cold cathode is transitioning from high vacuum to low vacuum and reaches a pressure above  $1.0E-2$  Torr, it will go into overcurrent and automatically power off to prevent damage to the sensor.

### 14.4 Automatic High Vacuum Switching

- 14.4.1 Cold cathode sensors can be automatically switched on and off by Televac low vacuum sensors. When in automatic mode, the lowest channel with a low vacuum sensor will control the odd or even channel above it. For example, a low vacuum sensor connected to channel 1 will control cold cathode sensors connected to channels 3, 5, 7, and 9. A low vacuum sensor connected to channel 2 will control cold cathode sensors connected to channel 4, 6, and 8.

### 14.5 Additional Notes

- 14.5.1 Cold cathode sensors cannot be connected to channel 10.  
14.5.2 If a cold cathode sensor is connected to channel 1 or 2 it cannot be automatically controlled by a low vacuum sensor.  
14.5.3 The MX200 will not control any hot ion sensors.

## 15. Cleaning Sensors

### 15.1 Description

- 15.1.1 Sensors will become contaminated over time when they are used, leading to decreased accuracy. Contamination is used here as a general term for a variety of conditions including, but not limited to, oxidation and deposited materials on the internal portions of the sensor.

In many situations this contamination can be cleaned from the sensor to restore it to normal operation. Sensors must be removed from your vacuum system before cleaning; be sure to adhere to all safety procedures related to removing the sensors from your system. Note that the 1E and 1F piezo diaphragm sensors cannot be cleaned. CDGs must be returned to their manufacturer for service.

If the sensor is still providing inaccurate readings after cleaning, the anode assembly (for cold cathodes) or the entire sensor may need to be replaced, or the MX200 controller may need to be re-calibrated with the sensor.

### 15.2 2A and 4A Thermocouple and Convection Cleaning

- 15.2.1 2A thermocouple and 4A convection enhanced thermocouple sensors can be rinsed with acetone or methanol. Note that these sensors utilize internal filaments to make vacuum measurements. It is important that the geometry of these filaments is maintained to provide the most accurate readings. Care must therefore be taken during the rinsing process to prevent any changes to the filament geometry.

Ensure that the sensors are dry before re-installing them on your system to prevent the introduction of any unintended substances.

### 15.3 General Information on Cold Cathode Cleaning

- 15.3.1 We suggest bead blasting for all cold cathodes except the 7FC and 7FCS, but a fine grade Scotch-Brite pad can be used in situations where bead blasting is not available. We strongly recommend against using steel wool to clean cold cathodes. Steel wool can create small magnetic particles which can permanently damage the sensor when it is turned on.

## 15.4 7B Cold Cathode Cleaning

15.4.1 Refer to the following cross-sectional diagram while cleaning the 7B sensor:

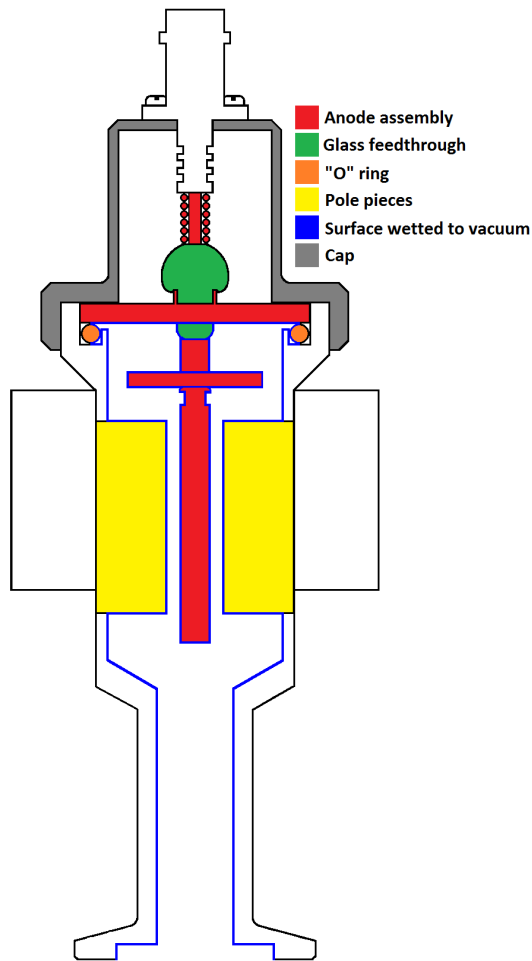

15.4.2 Cleaning steps:

15.4.2.1 Remove the cap by unscrewing it (labeled with gray in the diagram).

15.4.2.2 Pull the anode assembly out of the body (labeled with red in the diagram).

15.4.2.3 Remove the "O" ring from the body of the sensor, taking care not to scratch the "O" ring seat (labeled with orange in the diagram).

15.4.2.4 Wipe off the "O" ring with a lint free wipe.

15.4.2.5 Visually inspect the "O" ring for cracks or tears, it should also be round and not flattened. If any physical defects are found, the "O" ring should be replaced.

15.4.2.6 Blast the vacuum wetted portions of the anode assembly at 30 PSI using 70 to 140 mesh glass beads (labeled with red and blue in the diagram). Be careful not to damage the glass feedthrough at the base of the assembly (labeled with green in the diagram). If a rainbow effect is noticed on the glass feedthrough, a crack may exist and the anode assembly should be replaced. See below for relevant part numbers.

- 15.4.2.7 Blast the vacuum wetted portions of the body with glass beads (labeled with blue in the diagram), concentrating on the pole piece and “O” ring areas, but making sure to clean all surfaces wetted to vacuum. If the threaded end of the tube needs to be cleaned, it can be bead blasted as well.
- 15.4.2.8 After cleaning, use compressed dry air to remove any residual glass beads or dust from the sensor.
- 15.4.2.9 Ensure that there are no loose metal particles around the pole pieces.
- 15.4.2.10 Grease the “O” ring with Apiezon L or M Grease (a vacuum approved grease). The “O” ring should be shiny, be sure not to apply excess grease.
- 15.4.2.11 Install the “O” ring in the body.
- 15.4.2.12 Install the anode assembly in the body; observe the keyway location.
- 15.4.2.13 Replace the cap and hand tighten it.
- 15.4.2.14 Reinstall the sensor on the vacuum chamber.
- 15.4.2.15 Allow several hours for the sensor to degas when your system is pumped down to high vacuum.
- 15.4.2.16 If properly cleaned and assembled, the sensor is ready for use without re-calibration unless NIST traceable calibration is required.

15.4.3 Anode assembly part numbers:

Description	Part Number
7B anode assembly	2-6200-37

## 15.5 7E Cold Cathode Cleaning

15.5.1 Refer to the following cross-sectional diagram while cleaning the 7E sensor:

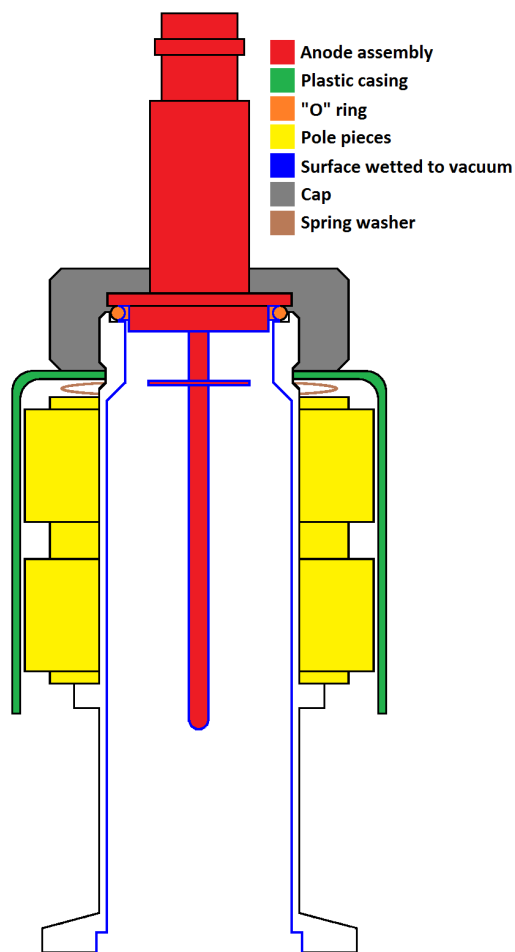

15.5.2 Cleaning steps:

15.5.2.1 Remove the cap by unscrewing it (labeled with gray in the diagram).

15.5.2.2 Remove the plastic casing (labeled with green in the diagram).

15.5.2.3 Remove the spring washer (labeled with brown in the diagram).

15.5.2.4 Pull the anode assembly out of the body (labeled with red in the diagram).

15.5.2.5 Remove the magnet assembly from the body (labeled with yellow in the diagram).

15.5.2.6 Remove the "O" ring from the body of the sensor, taking care not to scratch the "O" ring seat (labeled with orange in the diagram).

15.5.2.7 Wipe off the "O" ring with a lint free wipe.

15.5.2.8 Visually inspect the "O" ring for cracks or tears, it should also be round and not flattened. If any physical defects are found, the "O" ring should be replaced.

- 15.5.2.9 Blast the vacuum wetted portions of the anode assembly at 30 PSI using 70 to 140 mesh glass beads (labeled with red and blue in the diagram). Be careful not to damage the glass feedthrough at the base of the assembly. If a rainbow effect is noticed on the glass feedthrough, a crack may exist and the anode assembly should be replaced. See below for relevant part numbers.
- 15.5.2.10 Blast the vacuum wetted portions of the body with glass beads (labeled with blue in the diagram), concentrating on the areas surrounding the anode assembly, but making sure to clean all surfaces wetted to vacuum. If the threaded end of the tube needs to be cleaned, it can be bead blasted as well.
- 15.5.2.11 After cleaning, use compressed dry air to remove any residual glass beads or dust from the sensor.
- 15.5.2.12 Ensure that there are no loose metal particles around the pole pieces.
- 15.5.2.13 Grease the “O” ring with Apiezon L or M Grease (a vacuum approved grease). The “O” ring should be shiny, be sure not to apply excess grease.
- 15.5.2.14 Install the “O” ring in the body.
- 15.5.2.15 Install the magnet assembly on the body.
- 15.5.2.16 Install the spring washer on the body.
- 15.5.2.17 Install the anode assembly in the body; observe the keyway location.
- 15.5.2.18 Replace the plastic casing.
- 15.5.2.19 Replace the cap and hand tighten it.
- 15.5.2.20 Reinstall the sensor on the vacuum chamber.
- 15.5.2.21 Allow several hours for the sensor to degas when your system is pumped down to high vacuum.
- 15.5.2.22 If properly cleaned and assembled, the sensor is ready for use without re-calibration unless NIST traceable calibration is required.

### 15.5.3 Anode assembly part numbers

Description	Part Number
7E anode assembly	2-7900-51

## 15.6 7FC and 7FCS Cold Cathode Cleaning

15.6.1 Refer to the following cross-sectional diagram while cleaning the 7FC and 7FCS sensors. Note that the thermionic emitter is only included with the 7FCS.

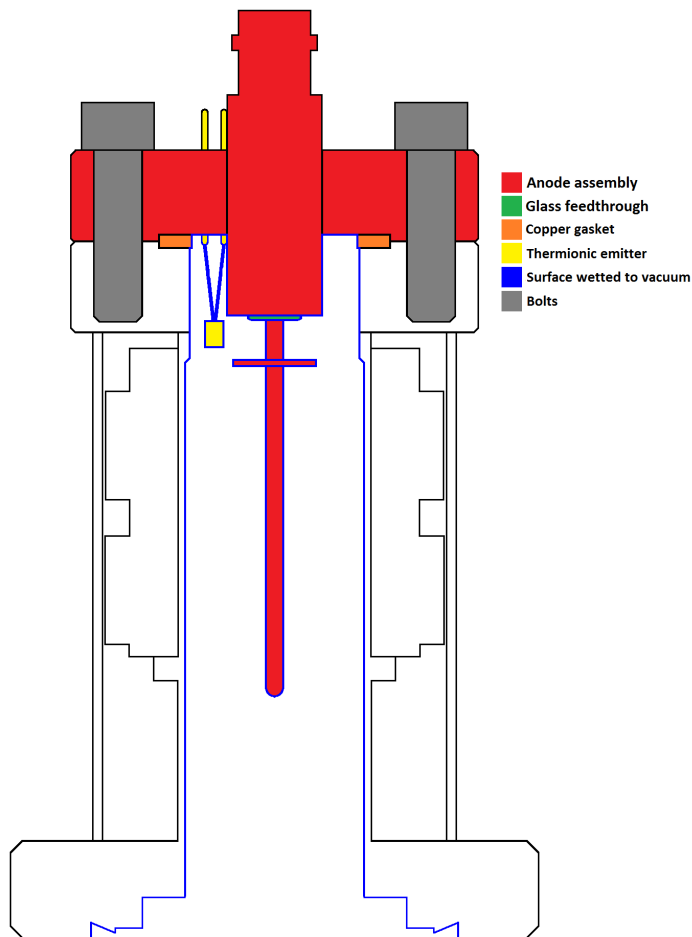

15.6.2 Cleaning steps:

15.6.2.1 Unscrew the 4 bolts from the top of the sensor (labeled with gray in the diagram).

15.6.2.2 Pull the anode assembly out of the body (labeled with red in the diagram).

15.6.2.3 Remove the copper gasket from the body of the sensor. Note that copper gaskets are one time use and should be replaced every time the sensor is disassembled.

15.6.2.4 Use a fine grade Scotch-Brite pad to clean the vacuum wetted portions of the anode assembly (with the exception of the thermionic emitter on the 7FCS). If a rainbow effect is noticed on the glass feedthrough, a crack may exist and the anode assembly should be replaced. See below for relevant part numbers. Take care not to damage the thermionic emitter on the 7FCS while cleaning.

15.6.2.5 Blast the vacuum wetted portions of the body with glass beads (labeled with blue in the diagram), concentrating on the areas surrounding the anode assembly, but making sure to clean all surfaces wetted to vacuum.

- 15.6.2.6 After cleaning, use compressed dry air to remove any residual glass beads or dust from the sensor.
- 15.6.2.7 Ensure that there are no loose metal particles attached to the inner body of the sensor.
- 15.6.2.8 Install a new copper gasket in the body.
- 15.6.2.9 Install the anode assembly in the body; observe the keyway location.
- 15.6.2.10        Replace the bolts and tighten them.
- 15.6.2.11        Reinstall the sensor on the vacuum chamber.
- 15.6.2.12        Allow several hours for the sensor to degas when your system is pumped down to high vacuum.
- 15.6.2.13        If properly cleaned and assembled, the sensor is ready for use without re-calibration unless NIST traceable calibration is required.

## 16. Understanding Cold Cathodes

### 16.1 Description

- 16.1.1 Cold cathodes provide indirect high vacuum measurement by ionizing gas molecules present in the vacuum chamber. Televac offers two types of cold cathodes; Penning (called the 7B) and double inverted magnetron (called the 7E, 7F, 7FC, and 7FCS).

Both types of cold cathodes have similar operating principles with a high voltage of 2 kV to 4 kV present between the anode and cathode, a magnet assembly to create a magnetic field in the ionization chamber, and utilization of current measurement to measure the pressure in the vacuum chamber.

Cold cathodes should not remain energized at pressures above  $1.0\text{E-}2$  Torr, and should not be maintained at pressures above  $1.0\text{E-}3$  for extended periods of time. If the cold cathode is energized at pressures above  $1.0\text{E-}3$  Torr for extended periods of time, particularly in environments where oxygen is present, rapid degradation of the sensor will occur due to contamination from sputtering of the cathode.

## 17. Capacitance Diaphragm Gauges (CDGs)

### 17.1 Description

- 17.1.1 Televac does not manufacture capacitance diaphragm gauges, but we do offer a module for the MX200 to interface with them. This allows the user to display readings from CDGs on the front panel of the MX200 and to output their values through analog 0 to 10 V DC outputs or digital communications. The MX200 can interface with any CDG from MKS Instruments, Inc. provided that it is a supported range (0.1, 1, 10, 100, or 1000 Torr full scale range) and that it draws less than 250 mA of current at 15 V DC.

## 18. Firmware Upgrades and the Bootloader

### 18.1 Description

- 18.1.1 The bootloader allows the user to upgrade the MX200 logic and display software from a computer through a serial communications program. Firmware upgrades must be completed through the USB connection on the communications module of the unit; other communication methods are not currently supported. These instructions assume the use of a Windows PC with Tera Term to upload the new version of the firmware.

### 18.2 Upgrading the Firmware

- 18.2.1 Download the updated version of the logic or display software to your computer.

- 18.2.2 Establish communications with the MX200 by following Televac Application Note 3008 (tfc\_an3008.pdf). Please contact Televac to request this document.

To enter the logic bootloader, send the following command and wait for the MX200 to enter the bootloader:

```
[USER TX] PG_LGC<cr>
[USER RX] Bootloader MX200 Logic VX.X<cr>
[USER RX] Waiting for download...<cr>
```

To enter the display bootloader, send the following command and wait for the MX200 to enter the bootloader:

```
[USER TX] PG_DSP<cr>
[USER RX] Bootloader MX200 Display VX.X<cr>
[USER RX] Waiting for download...<cr>
```

- 18.2.3 Ensure that Tera Term is configured for 57600 baud rate and Xon/Xoff flow control by viewing the settings in Setup>Serial port...
- 18.2.4 In Tera Term, go to File>Send file... then point to the update file that you downloaded in step 16.2.1.
- 18.2.5 Wait for Tera Term to complete the file transfer, note that this can take up to several minutes. Do not disconnect the MX200 from your computer or power down the MX200 or your computer during this process.
- 18.2.6 When the file transfer is complete, power cycle the MX200. If there are any issues, see Section 16.3 or contact Televac.
- 18.2.7 Your MX200 is now updated, enjoy!

## 18.3 Hardware Bootloader

- 18.3.1 If an error ever occurs during a software upgrade or if the bootloader is non-responsive, take the following steps to enter the bootloader with a hard reset:
- 18.3.2 Power down the MX200.
- 18.3.3 Locate the button on the communications module labeled BTLD.
- 18.3.4 Hold down the button and turn on the MX200. Continue holding down the button while the MX200 powers up for at least 3 seconds.
- 18.3.5 Follow the steps in Section 16.2 to restore the MX200 firmware.

## 19. Software Versioning

### 19.1 Description

- 19.1.1 The software version is a 6 digit number displayed during startup. It can be viewed with more detailed information once the unit has started by pressing the home key and selecting the Version Information at the bottom of the screen. Please have this information ready when you contact Televac with any questions about your unit.

## 20. Certifications

### 20.1 CE

20.1.1 EN61326-1:2006

### 20.2 UL

20.2.1 UL61010-1

### 20.3 RoHS

20.3.1 The logic, display, power supply, and communication modules are compliant with the Restriction of Hazardous Substances Directive 2002/95/EC (RoHS). Sensor modules are not RoHS compliant.

### 20.4 REACH

20.4.1 Compliant.

## 21. Troubleshooting

### 21.1 Cold Cathode Switching

21.1.1 **Question:** I'm using a rough vacuum sensor to automatically turn on my cold cathode. When the cold cathode turns on, it immediately jumps to a very low pressure reading that I know is incorrect. Why is this happening?

**Answer:** What's happening is that the cold cathode isn't starting properly, so it's reading zero current and the MX200 translates this to very low pressure. If the system is left for several minutes (up to 30 in extreme situations) the cold cathode will likely start and read a correct pressure. There are several reasons why this can happen, below are several suggestions for resolving the issue.

**Resolution 1:** Over time, rough vacuum sensors become contaminated from use. This typically causes the zero to drift up, which means that the cold cathode is turned on when the system is at a pressure where the cold cathode cannot turn on or "start". Recalibrating the rough vacuum sensor zero (see section 12) or replacing it will resolve the issue. If the sensor is replaced, it should also be recalibrated.

As an example, the standard turn on point for the cold cathode is when the rough vacuum sensor reaches  $1.0E-2$  Torr (10 mTorr, mTorr is equivalent to microns). If the rough sensor zero has drifted up from contamination, it could be reading  $1.0E-2$  Torr when the system is actually at  $1.0E-4$  Torr (0.1 mTorr). If the cold cathode is turned on at this pressure, it most likely will not start properly and will jump to a very low pressure reading.

**Resolution 2:** Contamination of the cold cathode can cause this behavior. Try disassembling and cleaning sensor and re-installing it on your system. Cleaning instructions for cold cathodes can be found in section 15. Remember to power down the MX200 and disconnect power before performing this service.

**Resolution 3:** If you have a new system where this is occurring, it's possible the behavior is caused by the pumping speed. In this situation, the rough vacuum sensor isn't reacting quickly enough and again the cold cathode is turned on at a pressure where it can't start. Try slowing down the pumping speed, changing the cold cathode port diameter, or moving the cold cathode to a location further from the pump.

**Resolution 4:** A damaged cold cathode cable can also cause this behavior. Try replacing the cable or contacting Televac for details about the cable to test its continuity. Remember to power down the MX200 and disconnect power before performing this service.

**Resolution 5:** A problem with the cold cathode module can cause this behavior. You can purchase a new module and replace it yourself (be sure to note the cold cathode model before purchasing a new module) or return the unit to Televac for service. Remember to power down the MX200 and disconnect power if you perform this service yourself.

**Resolution 6:** Contact Televac for an RMA. We are happy to evaluate the MX200 if you would like to return it to us. It's best if you can return the unit with all of the sensors and cables, but we understand this isn't always possible.

## 22. Vacuum Measurement Unit Conversions

### 22.1 Converting Between Torr Scientific, Torr Decimal, mTorr, and Microns

Torr Scientific	Torr Decimal	mTorr/Microns
1.0E-03	0.001	1
2.0E-03	0.002	2
3.0E-03	0.003	3
4.0E-03	0.004	4
5.0E-03	0.005	5
6.0E-03	0.006	6
7.0E-03	0.007	7
8.0E-03	0.008	8
9.0E-03	0.009	9
1.0E-02	0.010	10
2.0E-02	0.020	20
3.0E-02	0.030	30
4.0E-02	0.040	40
5.0E-02	0.050	50
6.0E-02	0.060	60
7.0E-02	0.070	70
8.0E-02	0.080	80
9.0E-02	0.090	90
1.0E-01	0.100	100
2.0E-01	0.200	200
3.0E-01	0.300	300
4.0E-01	0.400	400
5.0E-01	0.500	500
6.0E-01	0.600	600
7.0E-01	0.700	700
8.0E-01	0.800	800
9.0E-01	0.900	900

Torr Scientific	Torr Decimal	mTorr/Microns
1.0E+00	1	1000
2.0E+00	2	2000
3.0E+00	3	3000
4.0E+00	4	4000
5.0E+00	5	5000
6.0E+00	6	6000
7.0E+00	7	7000
8.0E+00	8	8000
9.0E+00	9	9000
1.0E+01	10	10,000
2.0E+01	20	20,000
3.0E+01	30	30,000
4.0E+01	40	40,000
5.0E+01	50	50,000
6.0E+01	60	60,000
7.0E+01	70	70,000
8.0E+01	80	80,000
9.0E+01	90	90,000
1.0E+02	100	100,000
2.0E+02	200	200,000
3.0E+02	300	300,000
4.0E+02	400	400,000
5.0E+02	500	500,000
6.0E+02	600	600,000
7.0E+02	700	700,000
8.0E+02	800	800,000
9.0E+02	900	900,000
1.00E+03	1000	1,000,000

## 23. Revision History

Rev #	Description	Initials	Date	Approval	Date
1.00	General release	SO	04/01/16	AO	04/01/16
1.01	Command updates to section 9	SO	04/07/16	AO	04/07/16
1.02	Updates to communications options	SO	05/13/16	AO	05/13/16
1.03	Addition of leak rate and mTorr	SO	06/21/16	AO	06/21/16
1.04	Added section 8.7	SO	06/23/16	AO	06/23/16
1.05	Modified section 9.11, 13.20.2	SO	06/24/16	AO	06/24/16
1.06	Modified/added sections 8.1.2, 8.3.1, 9.1.1, 13.18	SO	07/26/16	AO	07/26/16
1.07	Modified sections 9.1, 12.4	SO	01/06/17	AO	01/06/17
1.08	Modified section 10.7.6.4	SO	01/19/17	AO	01/19/17
A	Changed from revision numbers to letters	SO	04/20/17	AO	04/20/17
B	Updated logo and section 2.1, and "stations" now "channels"	SO	05/25/17	AO	05/25/17
C	See AR 6018	SO	04/04/18	AO	04/04/18