



OPERATING INSTRUCTIONS

EN

Translation of the Original

PKR 36X | **IKR 36X**
Pirani/cold cathode gauge | Cold cathode gauge

PFEIFFER  **VACUUM**

Dear customer,

Thank you for choosing a Pfeiffer Vacuum product. Your new gauge is designed to support you in your individual application with maximum performance and without malfunctions. The name Pfeiffer Vacuum stands for high-quality vacuum technology, a comprehensive and complete range of top-quality products and first-class service. From this extensive, practical experience we have gained a large volume of information that can contribute to efficient deployment and to your personal safety.

In the knowledge that our product must avoid consuming work output, we trust that our product can offer you a solution that supports you in the effective and trouble-free implementation of your individual application.

Please read these operating instructions before putting your product into operation for the first time. If you have any questions or suggestions, please feel free to contact info@pfeiffer-vacuum.de.

Further operating instructions from Pfeiffer Vacuum can be found in the [Download Center](#) on our website.

Disclaimer of liability

These operating instructions describe all models and variants of your product. Note that your product may not be equipped with all features described in this document. Pfeiffer Vacuum constantly adapts its products to the latest state of the art without prior notice. Please take into account that online operating instructions can deviate from the printed operating instructions supplied with your product.

Furthermore, Pfeiffer Vacuum assumes no responsibility or liability for damage resulting from the use of the product that contradicts its proper use or is explicitly defined as foreseeable misuse.

Copyright

This document is the intellectual property of Pfeiffer Vacuum and all contents of this document are protected by copyright. They may not be copied, altered, reproduced or published without the prior written permission of Pfeiffer Vacuum.

We reserve the right to make changes to the technical data and information in this document.

Table of contents

1	About this manual	7
1.1	Validity	7
	1.1.1 Applicable documents	7
	1.1.2 Variants	7
1.2	Target group	8
1.3	Conventions	8
	1.3.1 Instructions in the text	8
	1.3.2 Pictographs	9
	1.3.3 Stickers on the product	9
	1.3.4 Abbreviations	9
1.4	Trademarks	10
2	Safety	11
2.1	General safety instructions	11
2.2	Safety instructions	11
2.3	Safety precautions	14
2.4	Proper use	15
2.5	Foreseeable improper use	15
2.6	Responsibilities and warranty	15
2.7	Owner requirements	15
2.8	Personnel qualification	15
	2.8.1 Ensuring personnel qualification	16
	2.8.2 Personnel qualification for maintenance and repair	16
	2.8.3 Advanced training with Pfeiffer Vacuum	16
2.9	Operator requirements	17
3	Transportation and storage	18
4	Product description	19
4.1	Identifying the product	19
4.2	Scope of delivery	19
4.3	Function	19
5	Installation	20
5.1	Establishing the vacuum connection	20
5.2	Removing/installing the electronic unit	21
5.3	Establishing the electrical connection	23
6	Operation	25
6.1	Status display	25
6.2	Relation: measuring signal and pressure	26
6.3	Gas type dependence	28
6.4	Ignition delay	31
6.5	Contamination	31
7	Disassembly	33
8	Maintenance	35
8.1	Calibrating the PKR gauge	35
8.2	Maintaining the IKR gauge	36
8.3	Disassembling the gauge	37
8.4	Replacing the ignition aid	38
8.5	Cleaning of components	40
8.6	Identifying errors at the measurement chamber	41
8.7	Assembling the gauge	42
9	Malfunctions	44

10	Shipping	46
11	Disposal	47
12	Service solutions from Pfeiffer Vacuum	48
13	Ordering information	50
	13.1 Ordering parts	50
	13.2 Spare parts	50
	13.3 Accessories	51
14	Technical data and dimensions	52
15	Appendix	56
	15.1 Units of pressure	56
	15.2 Gas throughputs	56
	ETL Listed PKR	57
	ETL Listed IKR	58
	Declaration of Conformity PKR	59
	Declaration of Conformity IKR	60

List of tables

Tbl. 1:	Applicable documents	7
Tbl. 2:	PKR variants low voltage	7
Tbl. 3:	PKR variants high current	7
Tbl. 4:	IKR variants low voltage	8
Tbl. 5:	IKR variants high current	8
Tbl. 6:	Abbreviations used	9
Tbl. 7:	Illuminating diodes PKR	25
Tbl. 8:	Illuminating diodes IKR	26
Tbl. 9:	Operating modes PKR	26
Tbl. 10:	Constants PKR	27
Tbl. 11:	Constants IKR	28
Tbl. 12:	Calibration factors for the pressure range < 10 hPa PKR and IKR	31
Tbl. 13:	Measurement PKR	41
Tbl. 14:	Measurement IKR	41
Tbl. 15:	Malfunctions PKR	44
Tbl. 16:	Malfunctions IKR	45
Tbl. 17:	Spare parts	50
Tbl. 18:	Measuring and pressure values PKR	52
Tbl. 19:	Measuring and pressure values IKR	52
Tbl. 20:	Electrical data PKR	53
Tbl. 21:	Electrical data IKR	54
Tbl. 22:	Internal volume and weight	54
Tbl. 23:	Ambient conditions	54
Tbl. 24:	Temperatures	55
Tbl. 25:	Material against vacuum	55
Tbl. 26:	Units of pressure and their conversion	56
Tbl. 27:	Gas throughputs and their conversion	56

List of figures

Fig. 1:	PKR measuring configuration	19
Fig. 2:	Establishing the vacuum connection	21
Fig. 3:	Removing/installing the electronic unit (recommended for CF-F)	22
Fig. 4:	Connection diagram	23
Fig. 5:	Measurement cable and Hirschmann cable socket	24
Fig. 6:	Status display	25
Fig. 7:	Relation: measuring signal and pressure PKR	26
Fig. 8:	Relation: measuring signal and pressure IKR	27
Fig. 9:	Pressure range > 10 hPa with solely Pirani operation PKR	28
Fig. 10:	Pressure range from 10 to 0.1 hPa PKR	29
Fig. 11:	Displayed pressure IKR	30
Fig. 12:	Disassembling the gauge	33
Fig. 13:	Calibrating the PKR gauge	36
Fig. 14:	Disassembling the gauge	37
Fig. 15:	Removing the ignition aid	38
Fig. 16:	Inserting the ignition aid in the mounting tool	39
Fig. 17:	Inserting the ignition aid	39
Fig. 18:	Contact pins of the measurement chamber	41
Fig. 19:	Switch for calibration value CAL	42
Fig. 20:	Assembling the gauge	43
Fig. 21:	Complete measurement chamber (replacement sensor)	50
Fig. 22:	Dimensions	55

1 About this manual



IMPORTANT

Read carefully before use.
Keep the manual for future consultation.

1.1 Validity

This document describes the function of the products listed in the following and provides the most important information for safe use. The description is written in accordance with the valid directives. The information in this document refers to the current development status of the products. The document retains its validity assuming that the customer does not make any changes to the product.

1.1.1 Applicable documents

Designation	Document
Operating instructions "Total pressure measuring and control unit" TPG 361 TPG 362	BG 5500
Operating instructions "Total pressure measuring and control unit" TPG 366	BG 5501
Declarations of Conformity	(Part of this document)

Tbl. 1: Applicable documents

1.1.2 Variants

This document applies to products with the following part numbers:

Part number	Designation
PT T02 140 010	PKR 360 (DN 25 ISO-KF)
PT T02 140 011	PKR 360 C (DN 25 ISO-KF, ceramic coated)
PT T02 150 010	PKR 360 (DN 40 ISO-KF)
PT T02 150 011	PKR 360 C (DN 40 ISO-KF, ceramic coated)
PT T02 350 010	PKR 360 (DN 40 CF-F)
PT T02 350 011	PKR 360 C (DN 40 CF-F, ceramic coated)

Tbl. 2: PKR variants low voltage

Part number	Designation
PT T03 140 010	PKR 361 (DN 25 ISO-KF)
PT T03 140 011	PKR 361 C (DN 25 ISO-KF, ceramic coated)
PT T03 150 010	PKR 361 (DN 40 ISO-KF)
PT T03 150 011	PKR 361 C (DN 40 ISO-KF, ceramic coated)
PT T03 350 010	PKR 361 (DN 40 CF-F)
PT T03 350 011	PKR 361 C (DN 40 CF-F, ceramic coated)

Tbl. 3: PKR variants high current

Part number	Designation
PT T00 140 010	IKR 360 (DN 25 ISO-KF)
PT T00 140 011	IKR 360 C (DN 25 ISO-KF, ceramic coated)
PT T00 150 010	IKR 360 (DN 40 ISO-KF)
PT T00 150 011	IKR 360 C (DN 40 ISO-KF, ceramic coated)
PT T00 350 010	IKR 360 (DN 40 CF-F)
PT T00 350 011	IKR 360 C (DN 40 CF-F, ceramic coated)

Tbl. 4: IKR variants low voltage

Part number	Designation
PT T01 140 010	IKR 361 (DN 25 ISO-KF)
PT T01 140 011	IKR 361 C (DN 25 ISO-KF, ceramic coated)
PT T01 150 010	IKR 361 (DN 40 ISO-KF)
PT T01 150 011	IKR 361 C (DN 40 ISO-KF, ceramic coated)
PT T01 350 010	IKR 361 (DN 40 CF-F)
PT T01 350 011	IKR 361 C (DN 40 CF-F, ceramic coated)

Tbl. 5: IKR variants high current

Information that relates to only one of the devices is indicated as such. Unless otherwise indicated, the illustrations correspond to the device with DN 25 ISO-KF vacuum connection, however, also apply to the other vacuum connections accordingly.

The part number is found on the rating plate of the product.

Pfeiffer Vacuum reserves the right to make technical changes without prior notification.

The figures in this document are not to scale (dimensions in mm).

1.2 Target group

These operating instructions are aimed at all persons performing the following activities on the product:

- Transportation
- Setup (Installation)
- Usage and operation
- Decommissioning
- Maintenance and cleaning
- Storage or disposal

The work described in this document is only permitted to be performed by persons with the appropriate technical qualifications (expert personnel) or who have received the relevant training from Pfeiffer Vacuum.

1.3 Conventions

1.3.1 Instructions in the text

Usage instructions in the document follow a general structure that is complete in itself. The required action is indicated by an individual step or multi-part action steps.

Individual action step

A horizontal, solid triangle indicates the only step in an action.

- ▶ This is an individual action step.

Sequence of multi-part action steps

The numerical list indicates an action with multiple necessary steps.

1. Step 1
2. Step 2
3. ...

1.3.2 Pictographs

The pictographs used in the document indicate useful information.



Note



Tip



Wear laboratory gloves



Perform a visual inspection

1.3.3 Stickers on the product

This section describes all the stickers on the product along with their meaning.

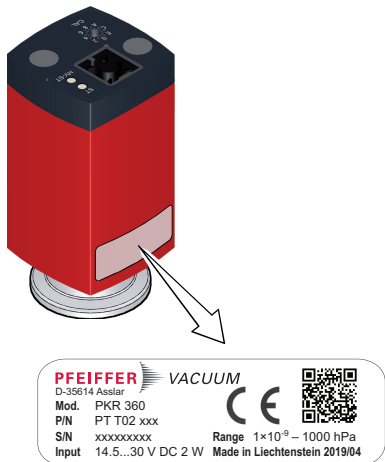
 <p>PFEIFFER VACUUM D-35614 Astlar Mod. PKR 360 P/N PT T02 xxx S/N xxxxxxxxx Input 14.5...30 V DC 2 W Range 1×10^{-9} – 1000 hPa Made in Liechtenstein 2019/04</p>	<p>Rating plate The rating plate is located on the back of the device.</p>
---	--

1.3.4 Abbreviations

Abbreviation	Explanation
ATM	Atmosphere
HV	High vacuum
cpl.	Complete unit
MSL	Mean sea level
s	Seconds
WAF	Width across flats

Tbl. 6: Abbreviations used

1.4 Trademarks

- FullRange® is a trademark of Pfeiffer Vacuum GmbH.

2 Safety

2.1 General safety instructions

This document includes the following four risk levels and one information level.

DANGER

Imminent danger

Indicates a hazardous situation which, if not avoided, will result in death or serious injury.

- ▶ Instructions on avoiding the hazardous situation

WARNING

Possibly imminent danger

Indicates a hazardous situation which, if not avoided, could result in death or serious injury.

- ▶ Instructions on avoiding the hazardous situation

CAUTION

Possibly imminent danger

Indicates a hazardous situation which, if not avoided, could result in minor or moderate injury.

- ▶ Instructions on avoiding the hazardous situation

NOTICE

Danger of property damage

Notice is used to address practices not related to physical injury.

- ▶ Instructions on avoiding property damage



Notes, tips or examples indicate important information on the product or on this document.

2.2 Safety instructions



Safety instructions according to product's life stages

All safety instructions in this document are based on the results of a risk assessment. Pfeiffer Vacuum has taken into account all the relevant life stages of the product.

Risks during transportation

NOTICE

Damage caused by incorrect transportation

Transportation in unsuitable packaging, or failure to install all transport locks, can damage the product.

- ▶ Comply with the instructions for safe transportation.

Risks during storage

NOTICE

Damage caused by improper storage

Improper storage will lead to damage to the product.

Static charging, moisture, etc. lead to defects on the electronic components.

- ▶ Comply with the instructions for safe storage.

Risks during installation

⚠ DANGER

Danger to life due to dangerous contact voltage

Voltages above 30 V (AC) or 60 V (DC) are considered dangerous in accordance with EN 61010. If you come into contact with dangerous contact voltage, this can result in injury through electric shocks or even death.

- ▶ Only connect the product to devices which meet the following criteria:
 - Requirements of the earthed protective extra-low voltage (PELV)
 - Limited power source (LPS) Class 2
- ▶ Secure the line to the product.
 - Pfeiffer Vacuum measuring and control equipment complies with this requirement.

⚠ DANGER

Risk to life due to electric shock

An improperly earthed product is potentially fatal in the event of a fault.

- ▶ Connect the product galvanically with the earthed vacuum chamber.
- ▶ Ensure that the connection complies with the requirements of a protective bonding according to EN 61010. (CF and VCR connections comply with this requirement.)
- ▶ Use electrically conductive centering rings and circlips for KF connections.

NOTICE

Damage sustained as a result of improper connection

Improper connection, incorrect polarity or impermissible supply voltage will damage the gauge.

- ▶ Always connect the supply earth (Pin 5) with the earth for the supply unit.
- ▶ Always connect the shielding (Pin 6) with the earth for the supply unit.

Risks during operation

⚠ WARNING

Risk of injury resulting from overpressure in the vacuum system

Opening tensioning pieces with an overpressure > 1000 hPa in the vacuum system can lead to injuries as a result of flying parts, and escaping process medium could prove harmful to health.

Elastomer seals in KF connections (e.g. O-rings) are not resistant to pressures > 2500 hPa. This could prove harmful to health due to escaping process medium.

- ▶ Do not open any tensioning pieces when overpressure is prevalent in the vacuum system.
- ▶ Use suitable tensioning pieces for overpressure.
- ▶ Use tensioning pieces which can only be opened and closed using a tool (e.g. tightening strap-circlip).
- ▶ Use sealing rings with an outer centering ring.

Risks during maintenance

⚠ DANGER

Risk to life due to electric shock

If no earth connection is established, voltage flows become hazardous to the touch and could lead to electronic components sustaining damage.

- ▶ Always tighten the electronic unit with the grub screw.
- ▶ Ensure that the grub screw of the electronic unit has been tightened correctly.

⚠ DANGER**Electric shocks due to moisture penetrating into the device**

Moisture that has penetrated into the device results in personal injury through electric shocks.

- ▶ Only operate the device in a dry environment.
- ▶ Operate the device away from fluids and humidity sources.
- ▶ Do not switch on the device if fluid has penetrated into it, instead contact Pfeiffer Vacuum Service.
- ▶ Always disconnect the current supply before cleaning the device.

⚠ WARNING**Health hazard through poisoning from toxic contaminated components or devices**

Toxic process media result in contamination of devices or parts of them. During maintenance work, there is a risk to health from contact with these poisonous substances. Illegal disposal of toxic substances causes environmental damage.

- ▶ Take suitable safety precautions and prevent health hazards or environmental pollution by toxic process media.
- ▶ Decontaminate affected parts before carrying out maintenance work.
- ▶ Wear protective equipment.

⚠ WARNING**Health hazards due to cleaning agent**

The cleaning agents used cause health hazards.

- ▶ When handling cleaning agents, observe the applicable regulations.
- ▶ Adhere to safety measures regarding handling and disposal of cleaning agents.
- ▶ Be aware of potential reactions with product materials.

NOTICE**Impairment from contamination and damage**

Touching the devices or components with bare hands increases the desorption rate and leads to incorrect measurements. Dirt (e.g. dust, fingerprints, etc.) and damage impair the function.

- ▶ During assembly and maintenance work on high or ultra high vacuum systems, always wear clean, lint-free and powder-free laboratory gloves.
- ▶ Only use clean tools.
- ▶ During assembly, ensure for connecting flanges free of grease.
- ▶ Remove protective caps and protective covers from flanges and connections only when necessary.
- ▶ Carry out all work in a well lit area.

NOTICE**Electric flashover from helium**

Helium can cause electric flashovers in the unit's electronics which will destroy the electronics.

- ▶ Switch off the unit before carrying out a leak test.
- ▶ Remove the electronic unit before carrying out a leak test.

NOTICE**Damage caused by penetrating moisture**

Penetrating moisture, e.g. through condensation or dripping water, damages the device.

- ▶ Protect the device against moisture penetrating.
- ▶ Only operate the device in a clean and dry environment.
- ▶ Operate the device away from fluids and humidity sources.
- ▶ Take special precautions if there is a risk of dripping water.
- ▶ Do not switch on the device if fluid has penetrated into it, instead contact the Pfeiffer Vacuum Service Center.

NOTICE

Damage caused by unsuitable cleaning agents

Unsuitable cleaning agents damage the product.

- ▶ Do not use solvents as they attack the surface.
- ▶ Do not use any aggressive or abrasive cleaning agents.

Risks when shipping

⚠ WARNING

Risk of poisoning from contaminated products

Where products that contain harmful substances are shipped for maintenance or repair purposes, the safety of service personnel is at risk.

- ▶ Comply with the instructions for safe shipping.

Risks during disposal

⚠ CAUTION

Health hazard caused by environmentally hazardous substances

Products, operating fluid, electric components, calibration gas residues (for example from test leaks) or similar pose health hazards.

- ▶ Dispose of the environmentally hazardous substances in accordance with local regulations.
- ▶ Dispose of calibration gas and test leaks in accordance with local regulations.

2.3 Safety precautions

The product is designed according to the latest technology and recognized safety engineering rules. Nevertheless, improper use can result in danger to operator all third party life and limb, and product damage and additional property damage.



Duty to provide information on potential dangers

The product holder or user is obliged to make all operating personnel aware of dangers posed by this product.

Every person who is involved in the installation, operation or maintenance of the product must read, understand and adhere to the safety-related parts of this document.



Infringement of conformity due to modifications to the product

The Declaration of Conformity from the manufacturer is no longer valid if the operator changes the original product or installs additional equipment.

- Following the installation into a system, the operator is required to check and re-evaluate the conformity of the overall system in the context of the relevant European Directives, before commissioning that system.

Meet fundamental safety measures

1. When handling the gases and contaminated parts used, observe the applicable guidelines.
2. Observe the protective measures.
3. Observe the safety guidelines specified in this document.
 - All work is only permissible when observing the relevant guidelines and adhering to the protective measures.
4. Inform yourself about any contamination before starting work.
5. Pass on safety instructions to all other users.

2.4 Proper use

PKR gauge

The FullRange gauge provides a vacuum measurement of gases within the range of 1×10^{-9} up to **1000 hPa**.

The gauge can **not** be used for the measurement of highly flammable or combustible gases in the mixture with an oxidizing agent (e.g. atmospheric oxygen) within the explosion limits.

IKR gauge

The gauge provides a vacuum measurement of gases within the range of 1×10^{-9} up to 1×10^{-2} hPa.

Both gauges can be operated with a Pfeiffer Vacuum total pressure measuring and control unit or with an evaluation unit provided by the customer.

Using the product according to its intended purpose

1. Install, operate and maintain the product only in accordance with these operating instructions.
2. Comply with the application limits.
3. Observe the technical data.

2.5 Foreseeable improper use

Improper use of the product invalidates all warranty and liability claims. Any use that is counter to the purpose of the product, whether intentional or unintentional, is regarded as misuse, in particular:

- Use outside the mechanical and electrical application limits (technical data)
- Use with corrosive or explosive media, if this is not explicitly permitted
- Use outdoors
- Use after technical changes (on the inside or the outside of the product)
- Use with replacement or accessory parts that are unsuitable or are not approved

2.6 Responsibilities and warranty

Pfeiffer Vacuum shall assume no responsibilities and warranty if the operating company or a third party:

- disregards this document
- does not use the product for its intended purpose
- carries out any modifications to the product (conversions, changes, maintenance work, etc.) that are not listed in the corresponding product documentation
- operates the product with accessories that are not listed in the corresponding product documentation

The operator is responsible for the process media used

2.7 Owner requirements

Safety-conscious working

1. Only operate the product in a technically flawless state.
2. Operate the product in line with its intended purpose, safety and hazard-conscious and only in compliance with these operating instructions.
3. Fulfill the following instructions and monitor the observation of the following instructions:
 - Proper use
 - Generally applicable safety instructions and accident prevention regulations
 - International, national and locally applicable standards and guidelines
 - Additional product-related guidelines and regulations
4. Only use original parts or parts approved by Pfeiffer Vacuum.
5. Keep the operating instructions available at the place of installation.
6. Ensure personnel qualification.

2.8 Personnel qualification

The work described in this document may only be carried out by persons who have appropriate professional qualifications and the necessary experience or who have completed the necessary training as provided by Pfeiffer Vacuum.

Training people

1. Train the technical personnel on the product.
2. Only let personnel to be trained work with and on the product when under the supervision of trained personnel.
3. Only allow trained technical personnel to work with the product.
4. Before starting work, make sure that the commissioned personnel have read and understood these operating instructions and all applicable documents, in particular the safety, maintenance and repair information.

2.8.1 Ensuring personnel qualification

Specialist for mechanical work

Only a trained specialist may carry out mechanical work. Within the meaning of this document, specialists are people responsible for construction, mechanical installation, troubleshooting and maintenance of the product, and who have the following qualifications:

- Qualification in the mechanical field in accordance with nationally applicable regulations
- Knowledge of this documentation

Specialist for electrotechnical work

Only a trained electrician may carry out electrical engineering work. Within the meaning of this document, electricians are people responsible for electrical installation, commissioning, troubleshooting, and maintenance of the product, and who have the following qualifications:

- Qualification in the electrical engineering field in accordance with nationally applicable regulations
- Knowledge of this documentation

In addition, these individuals must be familiar with applicable safety regulations and laws, as well as the other standards, guidelines, and laws referred to in this documentation. The above individuals must have an explicitly granted operational authorization to commission, program, configure, mark, and earth devices, systems, and circuits in accordance with safety technology standards.

Trained individuals

Only adequately trained individuals may carry out all works in other transport, storage, operation and disposal fields. Such training must ensure that individuals are capable of carrying out the required activities and work steps safely and properly.

2.8.2 Personnel qualification for maintenance and repair



Advanced training courses

Pfeiffer Vacuum offers advanced training courses to maintenance levels II and III.

Adequately trained individuals are:

- **Maintenance level I**
 - Customer (trained specialist)
- **Maintenance level II**
 - Customer with technical education
 - Pfeiffer Vacuum service technician
- **Maintenance level III**
 - Customer with Pfeiffer Vacuum service training
 - Pfeiffer Vacuum service technician

2.8.3 Advanced training with Pfeiffer Vacuum

For optimal and trouble-free use of this product, Pfeiffer Vacuum offers a comprehensive range of courses and technical training.

For more information, please contact [Pfeiffer Vacuum technical training](#).

2.9 Operator requirements

Observing relevant documents and data

1. Read, observe and follow this operating instructions and the work instructions prepared by the operating company, in particular the safety and warning instructions.
2. Install, operate and maintain the product only in accordance with these operating instructions.
3. Carry out all work only on the basis of the complete operating instructions and applicable documents.
4. Comply with the application limits.
5. Observe the technical data.
6. Please contact the Pfeiffer Vacuum Service Center if your questions on operation or maintenance of the product are not answered by this operating manual.
 - You can find information in the [Pfeiffer Vacuum service area](#).

3 Transportation and storage

NOTICE

Damage caused by incorrect transportation

Transportation in unsuitable packaging, or failure to install all transport locks, can damage the product.

- ▶ Comply with the instructions for safe transportation.

NOTICE

Damage caused by improper storage

Improper storage will lead to damage to the product.

Static charging, moisture, etc. lead to defects on the electronic components.

- ▶ Comply with the instructions for safe storage.

Transporting the product safely

1. Observe the weight of the product.
2. Where possible, always transport or ship the product in the original packaging.
3. Always use dense and impact-proof packaging for the product.
4. Remove the existing protective cover and transport protections only immediately prior to installation.
5. Reattach transport locks and transport protections prior to each transport.

Storing the product safely

1. Store the product in a cool, dry, dust-free place, where it is protected against impacts and mechanical vibration.
2. Always use dense and impact-proof packaging for the product.
3. Where possible, store the product in the original packaging.
4. Store electronic components in antistatic packaging.
5. Maintain the permissible storage temperature.
6. Avoid extreme fluctuations of the ambient temperature.
7. Avoid high air humidity.
8. Seal connections with the original protective caps.
9. Protect the product with the original transport protections (where available).

4 Product description

4.1 Identifying the product

You will need all the data from the rating plate to safely identify the product when communicating with Pfeiffer Vacuum.

Recording rating plate data

1. Read the data on the product rating plate.
2. Record this data.
3. Always have all rating plate specifications to hand.

4.2 Scope of delivery

The shipment includes the following parts:

- Gauge
- Stylus (\varnothing 1.1 mm, PKR gauge only)
- Operating instructions

Unpacking the product and checking completeness of the shipment

1. Unpack the product.
2. Remove the transport fasteners, transport protection etc.
3. Store the transport fasteners, transport protection etc. in a safe place.
4. Check that the shipment is complete.
5. Ensure that no parts are damaged.

4.3 Function

PKR gauge

The gauge has 2 measuring systems:

- Pirani measuring system
- Cold cathode measuring system functioning to the principle of the inverted magnetron

The Pirani measuring circuit is switched on at all times. The cold cathode measuring circuit controlled by the Pirani measuring circuit is only activated by the gauge when the pressures reach $p < 1 \times 10^{-2}$ hPa. Specific linking of both measuring systems ensures that the measuring systems generally behave as one standardized measuring system for the user. The measuring signal is logarithmically dependent on the pressure across the entire measuring range.

The gauge applies the optimum measuring configuration for the respective pressure range:

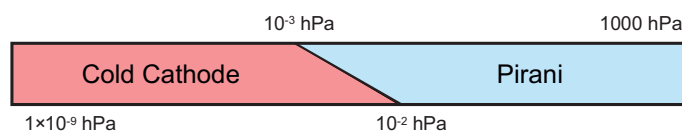

Fig. 1: PKR measuring configuration

IKR gauge

The gauge has a cold cathode measuring system functioning to the principle of the inverted magnetron. The measuring signal is logarithmically dependent on the pressure across the entire measuring range.

5 Installation

5.1 Establishing the vacuum connection

⚠ DANGER

Risk to life due to electric shock

An improperly earthed product is potentially fatal in the event of a fault.

- ▶ Connect the product galvanically with the earthed vacuum chamber.
- ▶ Ensure that the connection complies with the requirements of a protective bonding according to EN 61010. (CF and VCR connections comply with this requirement.)
- ▶ Use electrically conductive centering rings and circlips for KF connections.

⚠ DANGER

Risk to life due to electric shock

If no earth connection is established, voltage flows become hazardous to the touch and could lead to electronic components sustaining damage.

- ▶ Always tighten the electronic unit with the grub screw.
- ▶ Ensure that the grub screw of the electronic unit has been tightened correctly.

⚠ WARNING

Risk of injury resulting from overpressure in the vacuum system

Opening tensioning pieces with an overpressure $> 1000 \text{ hPa}$ in the vacuum system can lead to injuries as a result of flying parts, and escaping process medium could prove harmful to health.

Elastomer seals in KF connections (e.g. O-rings) are not resistant to pressures $> 2500 \text{ hPa}$. This could prove harmful to health due to escaping process medium.

- ▶ Do not open any tensioning pieces when overpressure is prevalent in the vacuum system.
- ▶ Use suitable tensioning pieces for overpressure.
- ▶ Use tensioning pieces which can only be opened and closed using a tool (e.g. tightening strap-circlip).
- ▶ Use sealing rings with an outer centering ring.

NOTICE

Impairment from contamination and damage

Touching the devices or components with bare hands increases the desorption rate and leads to incorrect measurements. Dirt (e.g. dust, fingerprints, etc.) and damage impair the function.

- ▶ During assembly and maintenance work on high or ultra high vacuum systems, always wear clean, lint-free and powder-free laboratory gloves.
- ▶ Only use clean tools.
- ▶ During assembly, ensure for connecting flanges free of grease.
- ▶ Remove protective caps and protective covers from flanges and connections only when necessary.
- ▶ Carry out all work in a well lit area.

NOTICE

Electric flashover from helium

Helium can cause electric flashovers in the unit's electronics which will destroy the electronics.

- ▶ Switch off the unit before carrying out a leak test.
- ▶ Remove the electronic unit before carrying out a leak test.

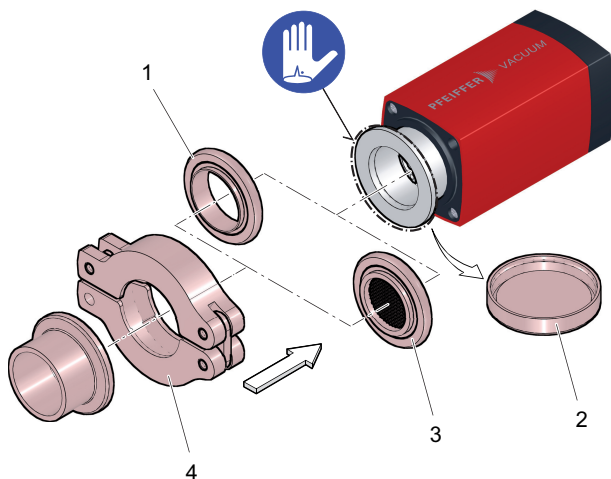

Fig. 2: Establishing the vacuum connection

- | | |
|----------------------------|---------------------------------------|
| 1 Seal with centering ring | 3 Seal with centering ring and filter |
| 2 Protective cap | 4 Tensioning piece |

Procedure

1. Ensure that the permissible operating temperature of the gauge is not exceeded.
2. Observe space required for the electrical connection (e.g. permissible bending radii for the cables).
3. Fit the gauge eliminating any exposure to vibrations where possible.
 - Vibrations at the gauge generally lead to deviations in the measured values.
4. Ensure a suitable mounting orientation.
5. Recommendation: Fit the gauge with horizontal to upright mounting orientation.
 - This will prevent condensate and particles from accumulating in the measurement chamber.
6. If necessary, fit a seal with centering ring and filter in the event of potential contamination during use, as well as to protect the measuring system against contamination.
7. Recommendation: Remove the electronic unit of the gauge temporarily if flange-mounting is only possible with the electronic unit removed.
 - This will facilitate installation of the CF flange connection.
8. Ensure that the button and the switch of the gauge can be easily accessed with the stylus once fitted.
9. Remove the protective cap and store it in a safe place.
10. Connect the gauge to the vacuum system.
11. If it was previously necessary to remove the electronic unit of the gauge, install the electronic unit once again.

5.2 Removing/installing the electronic unit

⚠ DANGER

Risk to life due to electric shock

An improperly earthed product is potentially fatal in the event of a fault.

- ▶ Connect the product galvanically with the earthed vacuum chamber.
- ▶ Ensure that the connection complies with the requirements of a protective bonding according to EN 61010. (CF and VCR connections comply with this requirement.)
- ▶ Use electrically conductive centering rings and circlips for KF connections.

⚠ DANGER

Risk to life due to electric shock

If no earth connection is established, voltage flows become hazardous to the touch and could lead to electronic components sustaining damage.

- ▶ Always tighten the electronic unit with the grub screw.
- ▶ Ensure that the grub screw of the electronic unit has been tightened correctly.

NOTICE

Impairment from contamination and damage

Touching the devices or components with bare hands increases the desorption rate and leads to incorrect measurements. Dirt (e.g. dust, fingerprints, etc.) and damage impair the function.

- ▶ During assembly and maintenance work on high or ultra high vacuum systems, always wear clean, lint-free and powder-free laboratory gloves.
- ▶ Only use clean tools.
- ▶ During assembly, ensure for connecting flanges free of grease.
- ▶ Remove protective caps and protective covers from flanges and connections only when necessary.
- ▶ Carry out all work in a well lit area.

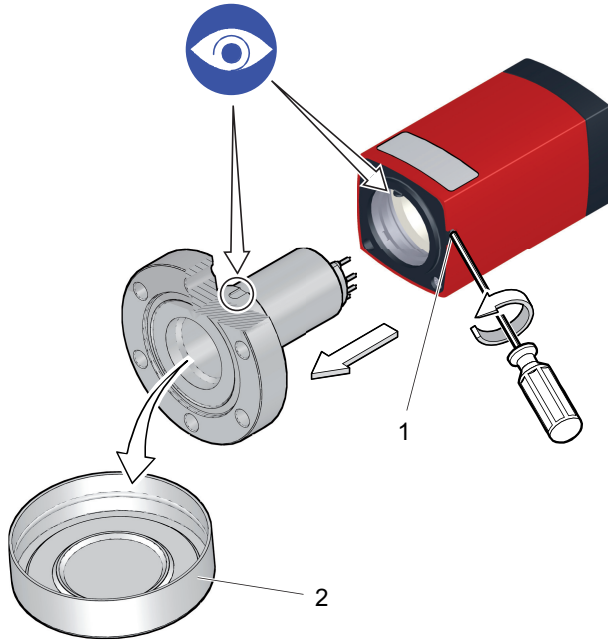

Fig. 3: Removing/installing the electronic unit (recommended for CF-F)

- 1 Allen head 2 WAF 2 Protective cap

Removing the electronic unit

Required tools

- Allen key (2 WAF)

1. Remove the electronic unit
 - to facilitate installation
 - to bake out of gauge
2. Loosen the grub screw on the side of the electronic unit.
3. Remove the electronic unit **without exerting any rotary movement.**

Installing the electronic unit

Required tools

- Allen key (2 WAF)

1. Carefully place the electronic unit.
2. Push the electronic unit as far as the stop.
3. Secure the grub screw on the side of the electronic unit.

5.3 Establishing the electrical connection

⚠ DANGER

Danger to life due to dangerous contact voltage

Voltages above 30 V (AC) or 60 V (DC) are considered dangerous in accordance with EN 61010. If you come into contact with dangerous contact voltage, this can result in injury through electric shocks or even death.

- ▶ Only connect the product to devices which meet the following criteria:
 - Requirements of the earthed protective extra-low voltage (PELV)
 - Limited power source (LPS) Class 2
- ▶ Secure the line to the product.
 - Pfeiffer Vacuum measuring and control equipment complies with this requirement.

NOTICE

Damage sustained as a result of improper connection

Improper connection, incorrect polarity or impermissible supply voltage will damage the gauge.

- ▶ Always connect the supply earth (Pin 5) with the earth for the supply unit.
- ▶ Always connect the shielding (Pin 6) with the earth for the supply unit.

To operate the gauge with a Pfeiffer Vacuum total pressure measuring and control unit, you will require a corresponding measurement cable from the [ActiveLine Accessories](#). Otherwise, you can also manufacture a measurement cable specifically for this purpose.

Establishing the electrical connection

Required tool

- Torque wrench (≤ 0.2 Nm)

Required material

- Measurement cable (as an accessory or manufactured for this purpose)
1. Connect the measurement cable to the gauge.
 2. Tighten the locking screw on the Hirschmann cable socket.
 - Tightening torque: ≤ 0.2 Nm

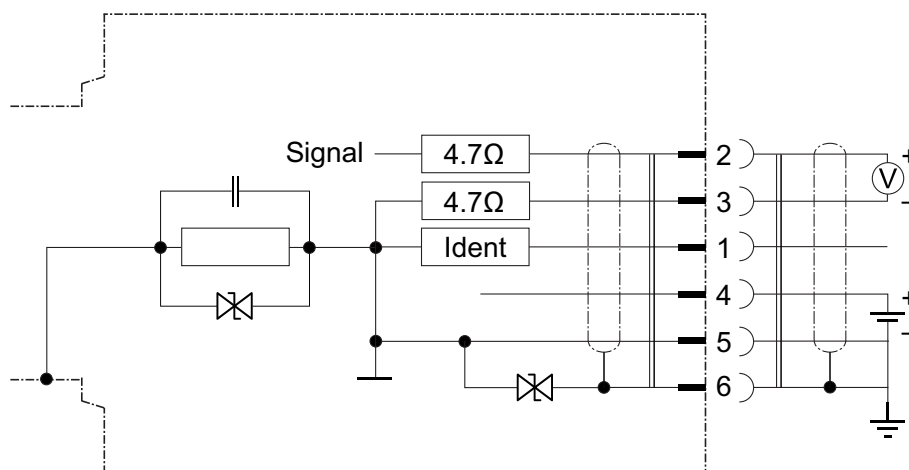

Fig. 4: Connection diagram

- | | |
|--------------------|------------------------|
| 1 Identification | 4 Supply |
| 2 Measuring signal | 5 Supply earth (GND) |
| 3 Signal earth | 6 Screening, shielding |

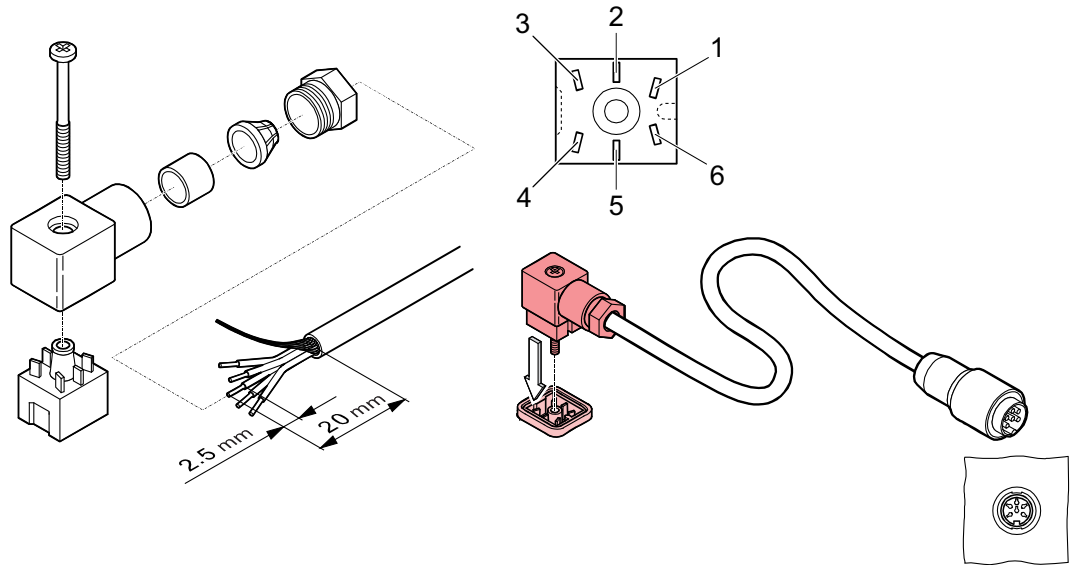

Fig. 5: Measurement cable and Hirschmann cable socket

Manufacturing a measurement cable

1. Observe the following steps to ensure optimum signal quality, whereby ground loops, differences in potential or EMC will influence the measuring signal.
 - Use a cable with braided shield and metallic connector housing.
 - Additional information regarding measurement cable type and conductor cross-sections can be obtained in the technical data.
 - Connect the supply earth directly with the protective earth for power supply pack.
 - Use a differential measuring input (separate signal earth and supply earth).
 - Ensure that the potential difference between supply earth and housing is $\leq 6\text{ V}$ (surge protection).
2. Assemble the Hirschmann cable socket.

Assembling the Hirschmann cable socket

Accessories required

- Hirschmann cable socket
1. Prepare the Hirschmann cable socket as shown in the "Measurement cable and Hirschmann cable socket" diagram.
 2. Solder in the connection cable as prescribed in the connection diagram.
 3. Assemble the Hirschmann cable socket.

6 Operation

Once the supply voltage has been established, the measuring signal is available at the electrical connection (Pins 2 and 3).

Operating the PKR gauge

1. Respect the stabilization period of at least 10 minutes.
2. Respect the relation between measuring signal and pressure.
3. Recommendation: Leave the gauge switched on at all times, regardless of the prevalent pressure.

Operating the IKR gauge

1. Respect the relation between measuring signal and pressure.
2. Only switch on the gauge with pressures $< 10^{-2}$ hPa to avoid excessive contamination.



Controlling the IKR gauge with a Pirani gauge

For Pfeiffer Vacuum total pressure measuring and control units with at least 2 gauge connections, the IKR gauge can be controlled with a Pirani gauge, for example.

6.1 Status display

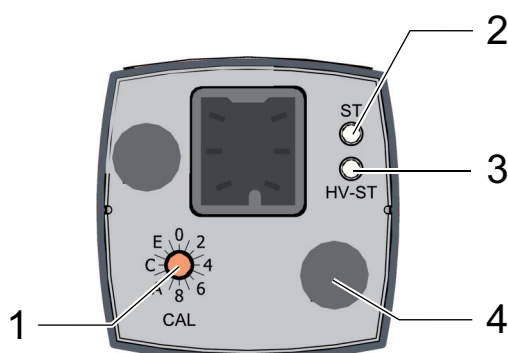

Fig. 6: Status display

- | | |
|--------------------------------------|---|
| 1 Switch for calibration value (CAL) | 3 LED "HV-ST" (high voltage/cold cathode) |
| 2 LED "ST" (supply voltage/error) | 4 (for factory setting only) |

LED		Meaning
"ST"	"HV-ST"	
Off	Off	No power supply
Lights up green	Off	Supply voltage OK, Pirani active, cold cathode off
Lights up yellow	Flashes green	Supply voltage OK, pressure in cold cathode range, cold cathode not ignited
Lights up green	Lights up green	Cold cathode ignited
Lights up red	Off	Measurement system error
Flashes red	Off	EEPROM error
Lights up yellow	Off	Measuring range exceeded
Lights up yellow	Lights up green	Measuring range not reached

Tbl. 7: Illuminating diodes PKR

LED		Meaning
"ST"	"HV-ST"	
Off	Off	No power supply
Lights up yellow	Off	Supply voltage OK, cold cathode off

LED		Meaning
"ST"	"HV-ST"	
Lights up yellow	Flashes green	Supply voltage OK, pressure in cold cathode range, cold cathode not ignited
Lights up green	Lights up green	Cold cathode ignited
Flashes red	Off	EEPROM error
Lights up yellow	Lights up green	Measuring range not reached or exceeded

Tbl. 8: Illuminating diodes IKR

Operating modes PKR

Pressure	LED		Operations mode	Identification
	"ST"	"HV-ST"		
$p > 1 \times 10^{-2}$ hPa	Lights up green	Off	Pirani operation	11.1 k Ω (Pirani)
$p < 1 \times 10^{-2}$ hPa	Lights up yellow	Flashes green	Pirani operation (cold cathode measuring system not ignited)	11.1 k Ω (Pirani)
	Lights up green		Combined operation	9.1 k Ω (combination)

Tbl. 9: Operating modes PKR

The identification output shows the respective operating status set for the PKR gauge. As long as the cold cathode measuring circuit has not ignited, the signal output issues solely the Pirani measured value once again (if $p < 5 \times 10^{-4}$ hPa: display "Pirani underrange").

6.2 Relation: measuring signal and pressure

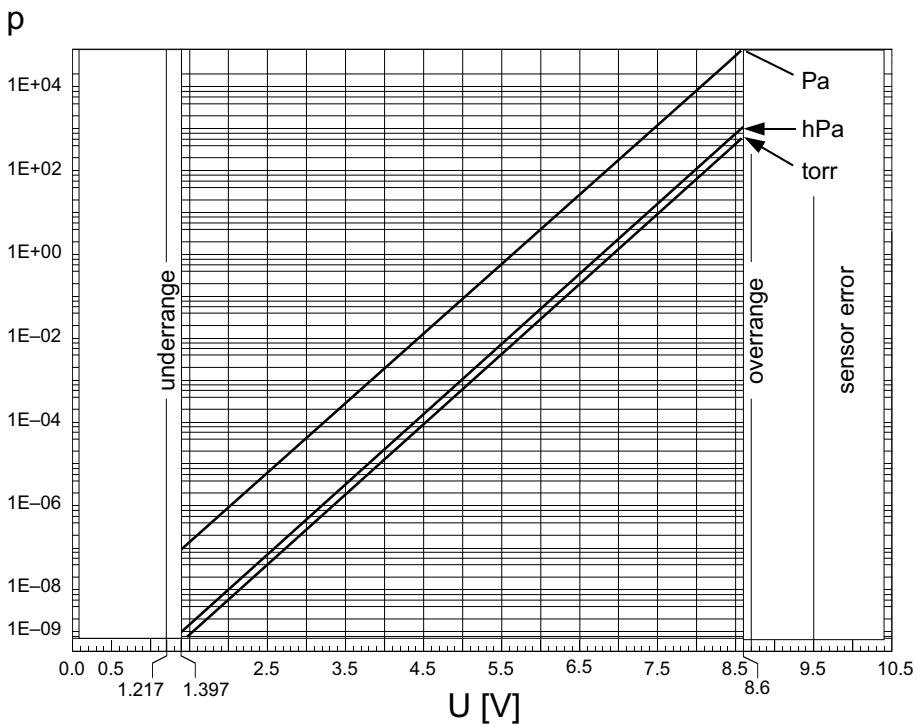

Fig. 7: Relation: measuring signal and pressure PKR

p Pressure U Measuring signal [V]

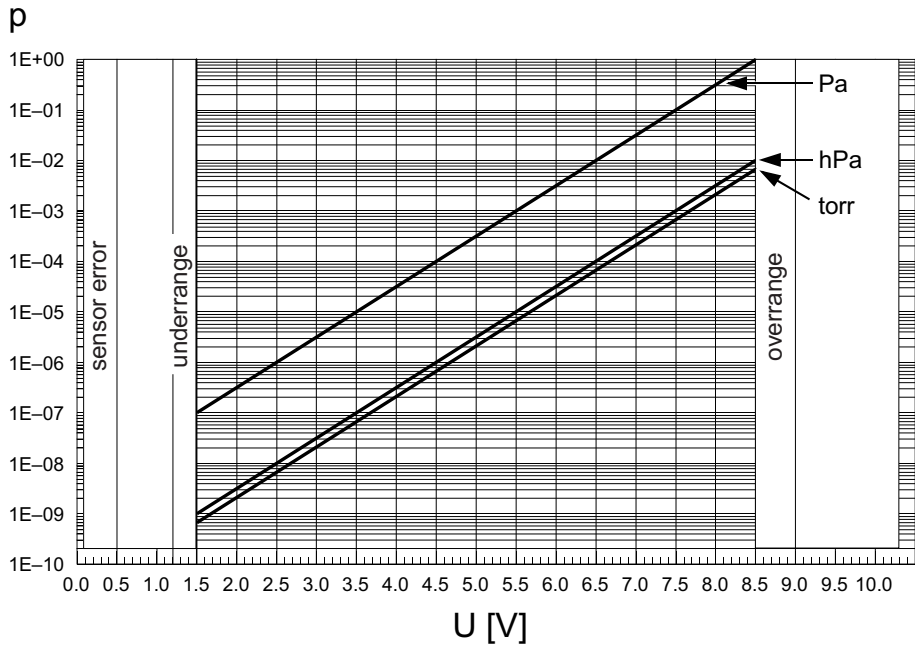

Fig. 8: Relation: measuring signal and pressure IKR

p Pressure U Measuring signal [V]

Calculation PKR

Validity range:

- $1 \times 10^{-9} \text{ hPa} < p < 1000 \text{ hPa}$
- $7.5 \times 10^{-10} \text{ Torr} < p < 750 \text{ Torr}$
- $1 \times 10^{-7} \text{ Pa} < p < 1 \times 10^5 \text{ Pa}$

Formula: $p = 10^{(1.667 \times U - d)} \leftrightarrow U = c + 0.6 \times \log_{10} p$

Measuring signal (U)	Pressure (p)	Constant (c) ¹⁾	Constant (d) ²⁾
[V]	[hPa]	6.8	11.33
	[mbar]		
	[Torr]	6.875	11.46
	[micron]	5.075	8.458
	[Pa]	5.6	9.333

Tbl. 10: Constants PKR

Calculation IKR

Validity range:

- $1 \times 10^{-9} \text{ hPa} < p < 1 \times 10^{-2} \text{ hPa}$
- $7.5 \times 10^{-10} \text{ Torr} < p < 7.5 \times 10^{-3} \text{ Torr}$
- $1 \times 10^{-7} \text{ Pa} < p < 1 \text{ Pa}$

Formula: $p = 10^{(U-c)} \leftrightarrow U = c + \log_{10} p$

1) Dependent upon unit of pressure
 2) Dependent upon unit of pressure

Measuring signal (U)	Pressure (p)	Constant (c) ³⁾
[V]	[hPa]	10.5
	[mbar]	
	[Torr]	10.625
	[micron]	7.625
	[Pa]	8.5

Tbl. 11: Constants IKR

6.3 Gas type dependence

The measuring signal is gas type dependent. The characteristics apply for nitrogen (N₂), oxygen (O₂), dry air and carbon monoxide (CO). When operating the gauge with a Pfeiffer Vacuum total pressure measuring and control unit (TPG), you can enter a calibration factor to adjust the displayed measured value.

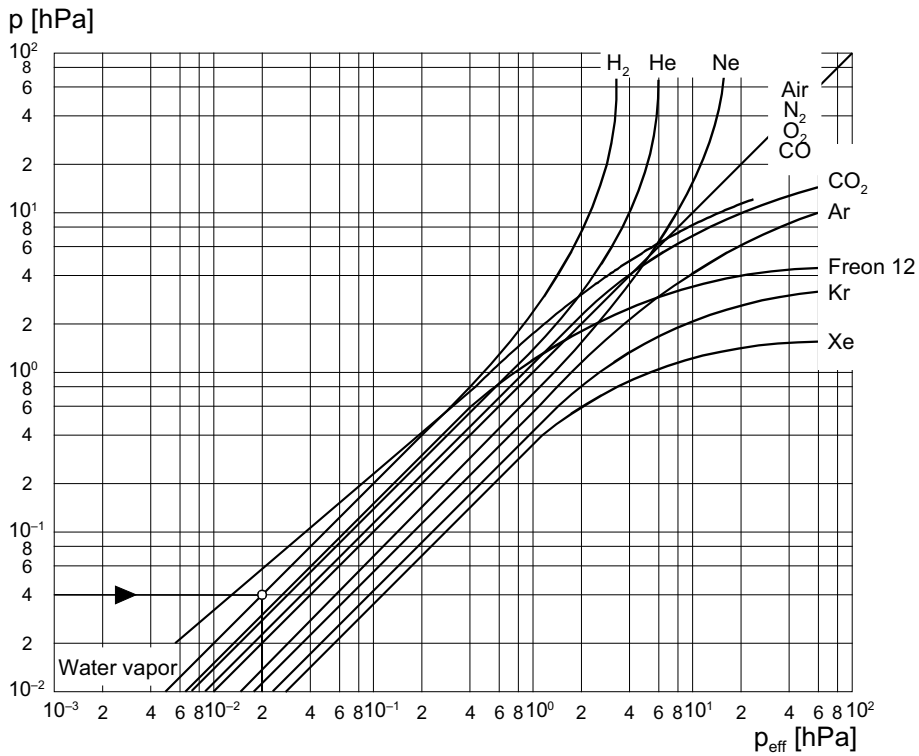

Fig. 9: Pressure range > 10⁻² hPa with solely Pirani operation PKR

3) Dependent upon unit of pressure

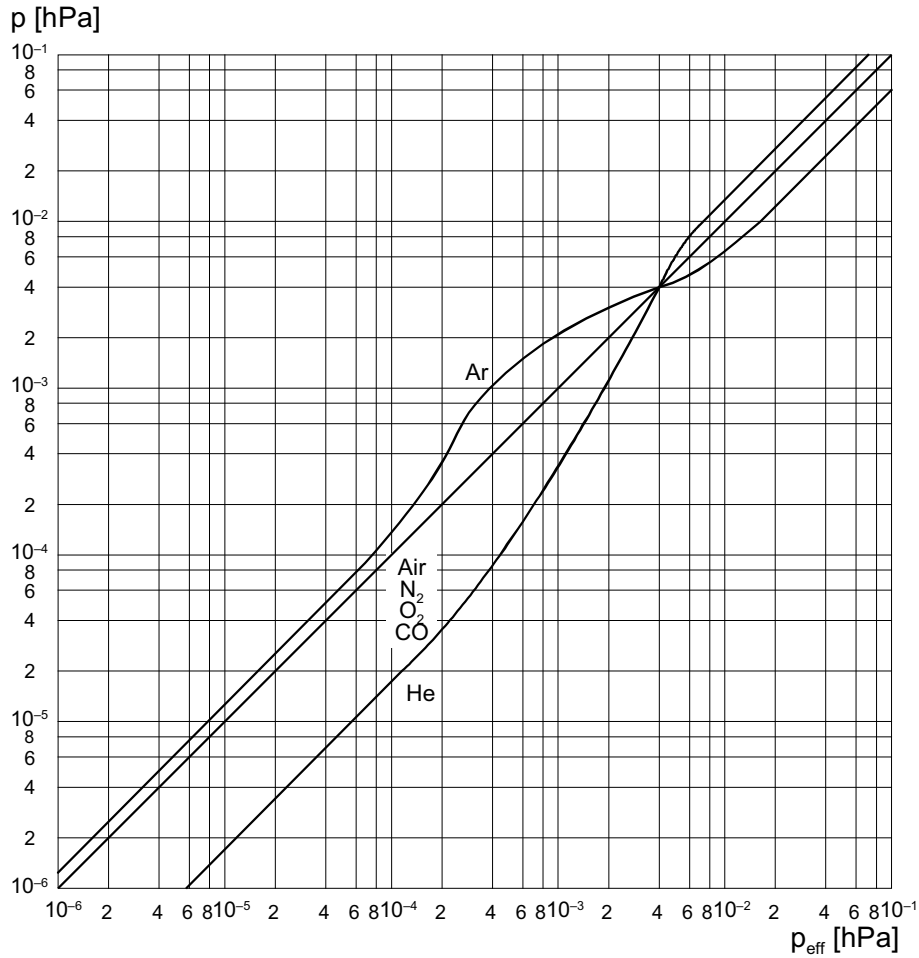

Fig. 10: Pressure range from 10^{-6} to 0.1 hPa PKR

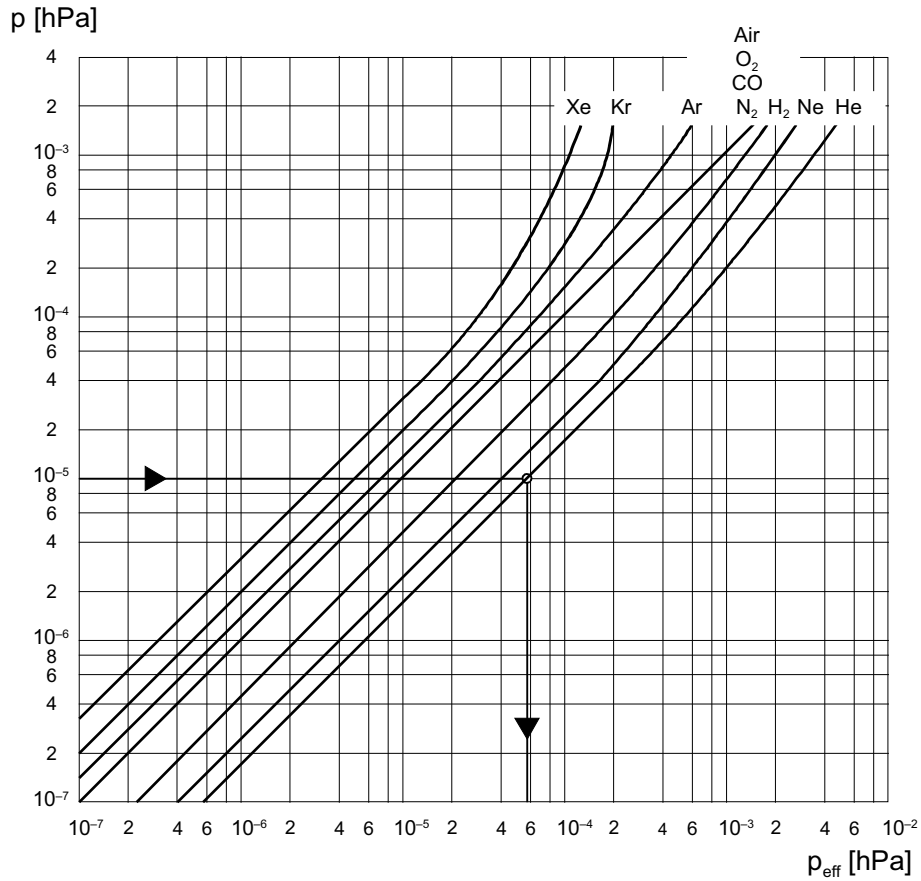

Fig. 11: Displayed pressure IKR

Calibration factors

Within the pressure range < 10⁻⁵ hPa, the display is linear. For other gases as air, you can determine the pressure by applying a simple conversion:

Calculation: $P_{\text{eff}} = C \times p$

- **P_{eff}**
Effective pressure
- **C**
Calibration factor
- **p**
Displayed pressure
(gauge calibrated for air)



Gas mixture

Mixtures of gases and vapors are often involved here. In such cases, precise measuring is only possible using partial pressure measurement instruments, for example a quadrupole mass spectrometer.

Gas type	Calibration factor (C)
Air, oxygen (O ₂), carbon monoxide (CO), nitrogen (N ₂)	1.0
Hydrogen (H ₂)	2.4
Helium (He)	5.9
Neon (Ne)	4.1
Argon (Ar)	0.8

The calibration factors provided are mean values.

Gas type	Calibration factor (C)
Krypton (Kr)	0.5
Xenon (Xe)	0.4

The calibration factors provided are mean values.

Tbl. 12: Calibration factors for the pressure range $< 10^{-5}$ hPa PKR and IKR

6.4 Ignition delay

Cold cathode measuring systems have an ignition delay upon activation. This ignition delay is longer for lower pressures and is typically in clean, degassed units:

- 1×10^{-5} up to 1×10^{-2} hPa < 1 second
- 1×10^{-7} up to 1×10^{-5} hPa < 20 seconds
- 5×10^{-9} up to 1×10^{-7} hPa < 2 minutes
- $< 5 \times 10^{-9}$ hPa < 20 minutes

The ignition is a static process, for which even minimal depositions can have a major influence on the inner surfaces.

PKR gauge



Activation with pressure $p < 3 \times 10^{-9}$ hPa

When activating the gauge with a pressure $p < 3 \times 10^{-9}$ hPa, the gauge will not detect any ignition of the cold cathode system. The gauge displays "Pirani underrange".



Maintaining operation of the gauge

If continuous operation of the flange-mounted gauge is maintained regardless of pressure range, the ignition delay time of the cold cathode measuring circuit is always negligible (< 1 s), with minimal thermal stabilization effects.

As long as the cold cathode measuring circuit has not ignited, the signal output issues solely the Pirani measured value once again (display "Pirani underrange" for pressures $p < 5 \times 10^{-4}$ hPa). The identification output signals solely Pirani operation.

6.5 Contamination



Warranty

Malfunctioning of the equipment as a direct result of wear or wear parts (e.g. ionization chamber) is not covered by the warranty.

Contamination of the gauge is dependent upon

- pressure in the vacuum chamber
- the type of process media
- potentially existing or newly accumulated contamination or its partial pressure (e.g. vapors, process particles etc.)
- the operating time

Continuous operation in the range between 10^{-4} hPa and 10^{-2} hPa can lead to major contamination, and thus reduced service life and shorter maintenance intervals.

Contamination of the gauge generally leads to deviations in the measured values:

- PKR only: Within the range of **high pressures** (1×10^{-3} hPa to 0.1 hPa), the pressure displayed is too high (contamination of the Pirani element). The Pirani measurement system must be recalibrated.
- PKR and IKR: Within the range of **low pressures** ($< 1 \times 10^{-3}$ hPa), the pressure displayed is generally too low (contamination of the cold cathode system). Excessive contamination will cause instabilities (separation of layers in the measurement chamber). This can lead to short circuiting.

Complete quenching of the gas discharge is also possible in the event of contamination resulting from insulating layers (display: "underrange").

Influencing the degree of contamination

It is possible to influence the level of contamination to a certain extent. Particular care should be afforded for vapors which are separated in the plasma (e.g. from the cold cathode measuring system).

1. Implement geometric safety measures (screening sheets, bends) for particles propagated in a straight line.
2. Choose a flange position in which the partial pressure of the contamination is at a minimum.
3. Switch off the gauge during the presence of separating vapors.

or

Seal off the gauge by means of a valve during the presence of separating vapors.

7 Disassembly

⚠ DANGER

Risk to life due to electric shock

An improperly earthed product is potentially fatal in the event of a fault.

- ▶ Connect the product galvanically with the earthed vacuum chamber.
- ▶ Ensure that the connection complies with the requirements of a protective bonding according to EN 61010. (CF and VCR connections comply with this requirement.)
- ▶ Use electrically conductive centering rings and circlips for KF connections.

⚠ WARNING

Risk of injury resulting from overpressure in the vacuum system

Opening tensioning pieces with an overpressure $> 1000 \text{ hPa}$ in the vacuum system can lead to injuries as a result of flying parts, and escaping process medium could prove harmful to health.

Elastomer seals in KF connections (e.g. O-rings) are not resistant to pressures $> 2500 \text{ hPa}$. This could prove harmful to health due to escaping process medium.

- ▶ Do not open any tensioning pieces when overpressure is prevalent in the vacuum system.
- ▶ Use suitable tensioning pieces for overpressure.
- ▶ Use tensioning pieces which can only be opened and closed using a tool (e.g. tightening strap-circlip).
- ▶ Use sealing rings with an outer centering ring.

NOTICE

Impairment from contamination and damage

Touching the devices or components with bare hands increases the desorption rate and leads to incorrect measurements. Dirt (e.g. dust, fingerprints, etc.) and damage impair the function.

- ▶ During assembly and maintenance work on high or ultra high vacuum systems, always wear clean, lint-free and powder-free laboratory gloves.
- ▶ Only use clean tools.
- ▶ During assembly, ensure for connecting flanges free of grease.
- ▶ Remove protective caps and protective covers from flanges and connections only when necessary.
- ▶ Carry out all work in a well lit area.

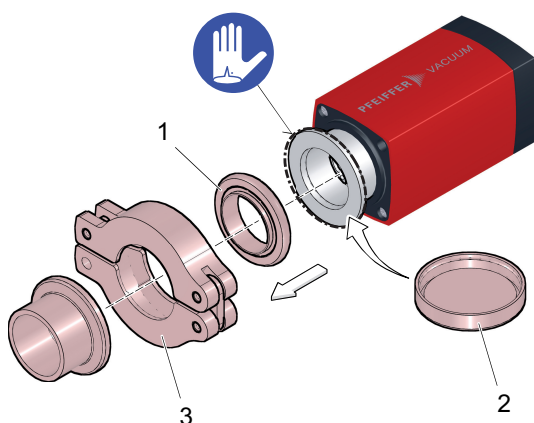

Fig. 12: Disassembling the gauge

- | | |
|----------------------------|--------------------|
| 1 Seal with centering ring | 3 Tensioning piece |
| 2 Protective cap | |

Disassembling the gauge

1. Vent the vacuum system.
2. Switch off the gauge.

3. Loosen the locking screw of the Hirschmann cable socket on the gauge.
4. Disconnect the measurement cable from the gauge.
5. Recommendation: Remove the electronic unit of the gauge temporarily if disassembling is only possible with the electronic unit removed.
 - This will facilitate disassembling the CF flange connection.
6. Disconnect the gauge from the vacuum system.
7. Put the protective cap on the connection flange.

8 Maintenance



Maintenance in the Pfeiffer Vacuum Service Center

Pfeiffer Vacuum offers a complete maintenance service for all products.

Pfeiffer Vacuum recommends: Contact your Pfeiffer Vacuum Service Center to arrange the maintenance of defective products and components.



Cleaning in the Pfeiffer Vacuum Service Center

Pfeiffer Vacuum recommends: Contact your nearest Pfeiffer Vacuum Service Center to arrange the cleaning of heavily-soiled products and components.



Loss of warranty claims

The following will result in the loss of the warranty:

- Damage to or removal of a closure seal
- Opening the device during the warranty period

Contact the Pfeiffer Vacuum Service Center in the event of process-related shorter maintenance intervals.



First read through the sections completely

Read the section with the work instructions through completely first before you commence with work.

8.1 Calibrating the PKR gauge

Pfeiffer Vacuum has calibrated the gauge to standard values at the factory.

The dominant cold cathode measuring circuit for the low pressure range ($< 1 \times 10^{-3}$ hPa) has been calibrated by Pfeiffer Vacuum to a fixed value at the factory. The HV calibration of the Pirani measuring circuit is performed automatically during operation at pressures $< 1 \times 10^{-5}$ hPa. The gauge stores the new zero point value every 15 minutes in the fail-safe memory. Calibration has a negligible influence on the pressure range between approximately 10^{-2} hPa and 10^2 hPa. A manual HV calibration is necessary when the gauge no longer outputs pressures $< 10^{-2}$ hPa.

Preparing for calibration

1. Perform a calibration at regular intervals.
 - Utilization in other climatic conditions, long-term operation, extreme temperatures, a different mounting orientation and aging or contamination can lead to a zero point shift in the Pirani measuring circuit. This will in turn necessitate recalibration or cleaning.
2. Perform the calibration under the same, consistent ambient conditions and with the same mounting orientation as normally used for the gauge.
3. Inspect any fitted seal with centering ring and filter for contamination.
4. Replace any fitted seal with centering ring and filter wherever these parts are contaminated or damaged.
5. Perform commissioning of the gauge.

You may now perform a calibration.

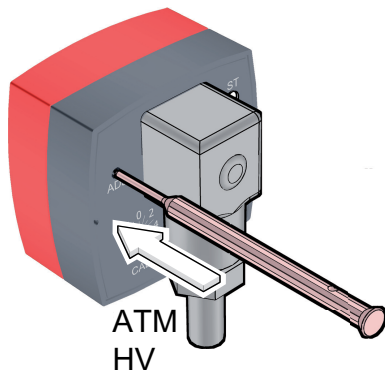

Fig. 13: Calibrating the PKR gauge

Performing an HV calibration

Required tool

- Stylus (max. \varnothing 1.1 mm)

1. Activate the gauge, as near as possible to the subsequent operating position.
2. Evacuate the vacuum system to $p < 10^{-5}$ hPa.
3. Wait for at least 2 minutes.
4. Press the "ADJ" button briefly with a stylus.
 - The Pirani sensor calibrates to 1×10^{-5} hPa (standard).
Calibration will take: approx. 5 seconds.
5. Repeat the calibration if the gauge at the measuring signal output does **not** display a pressure of $< 1 \times 10^{-5}$ hPa.
 - The calibration was not successful this time.

Performing an ATM calibration

Required tool

- Stylus (max. \varnothing 1.1 mm)

1. Activate the gauge, as near as possible to the subsequent operating position.
2. Allow the gauge to run for at least 10 minutes at atmospheric pressure.
3. Press the "ADJ" button briefly with a stylus.
 - The Pirani sensor calibrates to 1000 hPa (standard).
Calibration will take: approx. 5 seconds.
4. Repeat the calibration if a pressure of 1000 hPa is **not** displayed by the gauge at the measuring signal output.
 - The calibration was not successful this time.

8.2 Maintaining the IKR gauge

Pfeiffer Vacuum has calibrated the gauge to standard values at the factory. The gauge is maintenance-free.

Replacing faulty components

- ▶ Replace the ionization chamber and the ignition aid or the complete measurement chamber (replacement sensor) only if the unit is faulty.
- ▶ Replace the complete measurement chamber if heavily contaminated or faulty.

8.3 Disassembling the gauge

NOTICE

Impairment from contamination and damage

Touching the devices or components with bare hands increases the desorption rate and leads to incorrect measurements. Dirt (e.g. dust, fingerprints, etc.) and damage impair the function.

- ▶ During assembly and maintenance work on high or ultra high vacuum systems, always wear clean, lint-free and powder-free laboratory gloves.
- ▶ Only use clean tools.
- ▶ During assembly, ensure for connecting flanges free of grease.
- ▶ Remove protective caps and protective covers from flanges and connections only when necessary.
- ▶ Carry out all work in a well lit area.

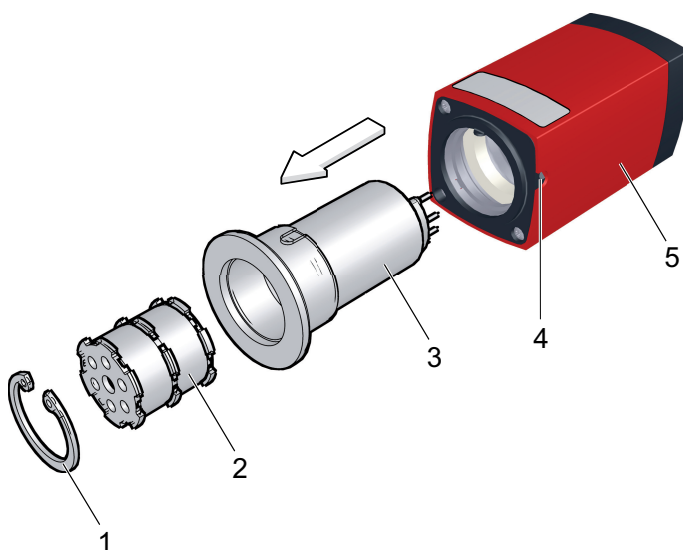

Fig. 14: Disassembling the gauge

- | | |
|-----------------------|-------------------|
| 1 Circlip | 4 Grub screw |
| 2 Ionization chamber | 5 Electronic unit |
| 3 Measurement chamber | |

Disassembling the gauge

Required tools

- Allen key (2 WAF)
- Pincers for circlip
- Tweezers

1. Disconnect the gauge from the vacuum system.
2. Loosen the grub screw on the side of the electronic unit.
3. Remove the complete measurement chamber from the electronic unit.
4. Remove the circlip.
5. Remove the ionization chamber from the measurement chamber.

8.4 Replacing the ignition aid

NOTICE

Impairment from contamination and damage

Touching the devices or components with bare hands increases the desorption rate and leads to incorrect measurements. Dirt (e.g. dust, fingerprints, etc.) and damage impair the function.

- ▶ During assembly and maintenance work on high or ultra high vacuum systems, always wear clean, lint-free and powder-free laboratory gloves.
- ▶ Only use clean tools.
- ▶ During assembly, ensure for connecting flanges free of grease.
- ▶ Remove protective caps and protective covers from flanges and connections only when necessary.
- ▶ Carry out all work in a well lit area.

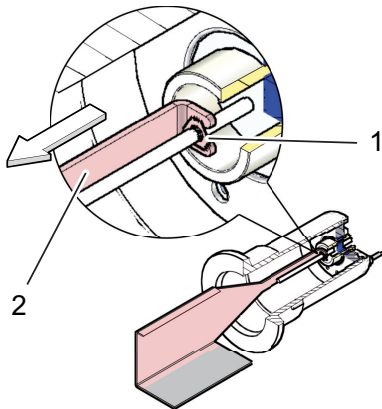

Fig. 15: Removing the ignition aid

1 Ignition aid 2 Mounting tool

Removing the ignition aid

Required tool

- Mounting tool for the ignition aid
or
Tweezers
- ▶ Remove the ignition aid.

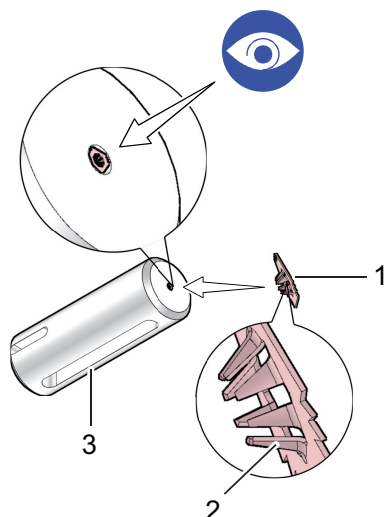

Fig. 16: Inserting the ignition aid in the mounting tool

- | | |
|--------------------------------|-----------------|
| 1 Ignition aid | 3 Mounting tool |
| 2 Serrated end of ignition aid | |

Inserting the ignition aid in the mounting tool

Required tool

- Mounting tool for the ignition aid

Spare part required

- Ignition aid
1. Insert the new ignition aid in the mounting tool.
 2. Ensure correct position of the ignition aid (serrated end at the bottom).

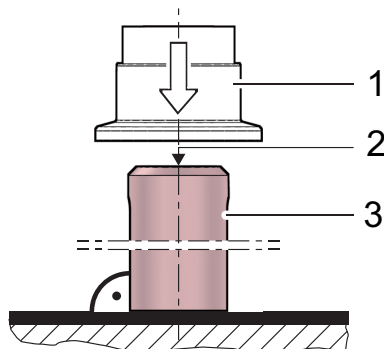

Fig. 17: Inserting the ignition aid

- | | |
|------------------------------------|-----------------|
| 1 Measurement chamber (with anode) | 3 Mounting tool |
| 2 Ignition aid | |

Inserting the ignition aid

Required tool

- Mounting tool for the ignition aid

Spare part required

- Ignition aid
- Carefully push the measurement chamber with anode (either new or cleaned) into the mounting tool, centrally and parallel to the tool axis up to the stop.

8.5 Cleaning of components

⚠ DANGER

Electric shocks due to moisture penetrating into the device

Moisture that has penetrated into the device results in personal injury through electric shocks.

- ▶ Only operate the device in a dry environment.
- ▶ Operate the device away from fluids and humidity sources.
- ▶ Do not switch on the device if fluid has penetrated into it, instead contact Pfeiffer Vacuum Service.
- ▶ Always disconnect the current supply before cleaning the device.

⚠ WARNING

Health hazards due to cleaning agent

The cleaning agents used cause health hazards.

- ▶ When handling cleaning agents, observe the applicable regulations.
- ▶ Adhere to safety measures regarding handling and disposal of cleaning agents.
- ▶ Be aware of potential reactions with product materials.

NOTICE

Damage caused by penetrating moisture

Penetrating moisture, e.g. through condensation or dripping water, damages the device.

- ▶ Protect the device against moisture penetrating.
- ▶ Only operate the device in a clean and dry environment.
- ▶ Operate the device away from fluids and humidity sources.
- ▶ Take special precautions if there is a risk of dripping water.
- ▶ Do not switch on the device if fluid has penetrated into it, instead contact the Pfeiffer Vacuum Service Center.

NOTICE

Damage caused by unsuitable cleaning agents

Unsuitable cleaning agents damage the product.

- ▶ Do not use solvents as they attack the surface.
- ▶ Do not use any aggressive or abrasive cleaning agents.

External cleaning of the device

Required consumables

- Industrial alcohol
- Cloth (soft, lint-free)

1. Always use a cloth soaked in industrial alcohol for external cleaning.
2. Allow the surfaces to dry thoroughly after cleaning.

Check components for contamination

1. Check the ionization chamber for contamination.
2. Check the measurement chamber for contamination.
3. Check the ignition aid for contamination.
4. Replace the ionization chamber if only the ionization chamber is contaminated.
5. Replace the complete measurement chamber if the measurement chamber is heavily contaminated.
6. Replace the ignition aid if the ignition aid is contaminated.

Cleaning of components

Required consumables

- Polishing cloth (400 grade or Scotch-Brite)
1. Disassemble the gauge to the degree required.
 2. Remove the old ignition aid.

3. Ensure that all work on the sealing surfaces is performed concentrically.
4. Do not bend the anode.
5. Rub the inside walls of the measurement chamber up to the groove of the circlip with the polishing cloth until shiny.
6. Insert a new ignition aid.
7. Assemble the gauge again.

8.6 Identifying errors at the measurement chamber

If you are already fairly certain of the cause of a measurement chamber malfunction, an approximate diagnosis can be carried out using an ohmmeter. Venting of the vacuum system is not necessary for this process.

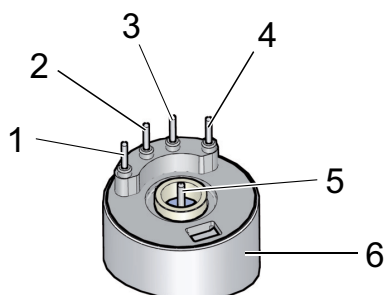

Fig. 18: Contact pins of the measurement chamber

1 – 5

Contact pin

6

Measurement chamber

Performing a resistance test

Prerequisite

- The electronic unit is removed.

Equipment required

- Ohmmeter

1. Perform the measurements at the contact pins of the measurement chamber using an ohmmeter.
2. Replace the complete measurement chamber if the measured value is outside of the setpoint range.

Measurement between	Setpoint range	Reasons for values being outside of setpoint range
1 and 4	39.5 – 40.5 Ω (at 20 °C)	Faulty Pirani filament
1 and 2	1000 – 1100 Ω (at 20 °C)	Faulty Pirani temperature sensor
5 and 6	∞	Value $\ll \infty$: contamination, short circuiting of cold cathode

Tbl. 13: Measurement PKR

Measurement between	Setpoint range	Reasons for values being outside of setpoint range
5 and 6	∞	Value $\ll \infty$: contamination, short circuiting of cold cathode

Tbl. 14: Measurement IKR

8.7 Assembling the gauge

⚠ DANGER

Risk to life due to electric shock

If no earth connection is established, voltage flows become hazardous to the touch and could lead to electronic components sustaining damage.

- ▶ Always tighten the electronic unit with the grub screw.
- ▶ Ensure that the grub screw of the electronic unit has been tightened correctly.

NOTICE

Impairment from contamination and damage

Touching the devices or components with bare hands increases the desorption rate and leads to incorrect measurements. Dirt (e.g. dust, fingerprints, etc.) and damage impair the function.

- ▶ During assembly and maintenance work on high or ultra high vacuum systems, always wear clean, lint-free and powder-free laboratory gloves.
- ▶ Only use clean tools.
- ▶ During assembly, ensure for connecting flanges free of grease.
- ▶ Remove protective caps and protective covers from flanges and connections only when necessary.
- ▶ Carry out all work in a well lit area.

NOTICE

Electric flashover from helium

Helium can cause electric flashovers in the unit's electronics which will destroy the electronics.

- ▶ Switch off the unit before carrying out a leak test.
- ▶ Remove the electronic unit before carrying out a leak test.

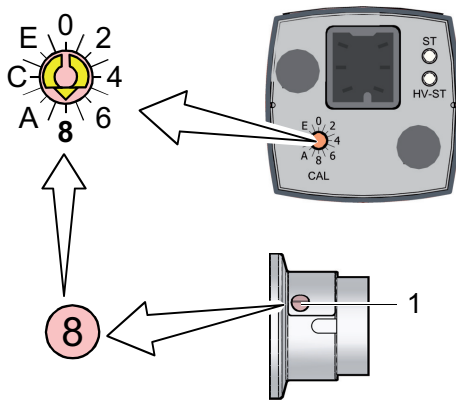

Fig. 19: Switch for calibration value CAL

- 1 Calibration value of replacement sensor (complete measurement chamber)

Setting the calibration value of the replacement sensor

When replacing the complete measurement chamber, the calibration value must be set on the replacement sensor.

- ▶ Set the calibration value for the replacement sensor at the switch for the calibration value (CAL) of the electronic unit.

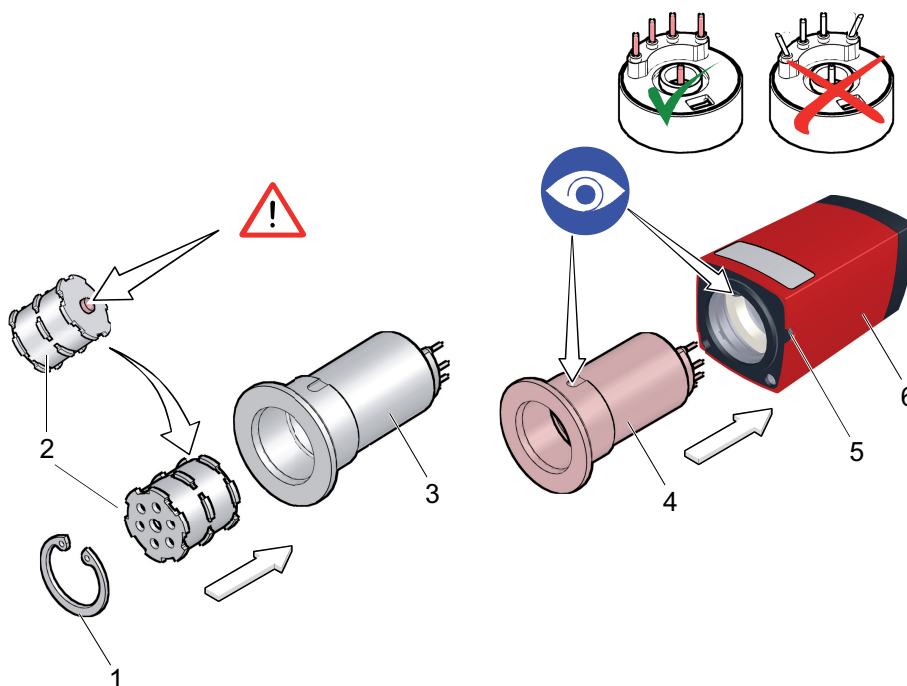

Fig. 20: Assembling the gauge

- | | |
|-----------------------|----------------------------------|
| 1 Circlip | 4 Measurement chamber (complete) |
| 2 Ionization chamber | 5 Grub screw |
| 3 Measurement chamber | 6 Electronic unit |

Assembling the PKR gauge

Required tools

- Allen key (2 WAF)
- Pincers for circlip
- Tweezers

1. Replace the ignition aid as required (see chapter "Replacing the ignition aid", page 38).
2. Observe arrangement of the ionization chamber.
3. Push the ionization chamber into the measurement chamber up to the mechanical stop.
4. Install the circlip.
5. Perform a leak test, if possible.
 - Leakage rate <math> < 10^{-9}</math> hPa l/s
6. Push the complete measurement chamber into the electronic unit up to the mechanical stop.
7. Ensure in this regard that the pins remain straight.
8. Secure the grub screw on the side of the electronic unit.
9. Perform a manual ATM and HV calibration.

Assembling the IKR gauge

Required tools

- Allen key (2 WAF)
- Pincers for circlip
- Tweezers

1. Replace the ignition aid as required (see chapter "Replacing the ignition aid", page 38).
2. Observe arrangement of the ionization chamber.
3. Push the ionization chamber into the measurement chamber up to the mechanical stop.
4. Install the circlip.
5. Perform a leak test, if possible.
 - Leakage rate <math> < 10^{-9}</math> hPa l/s
6. Push the complete measurement chamber into the electronic unit up to the mechanical stop.
7. Ensure in this regard that the pins remain straight.
8. Secure the grub screw on the side of the electronic unit.

9 Malfunctions



Warranty

Malfunctioning of the equipment as a direct result of wear or wear parts (e.g. ionization chamber) is not covered by the warranty.



Rectifying malfunctions (reset)

In the event of a malfunction, Pfeiffer Vacuum recommends disconnecting the supply voltage, and then reconnecting after 5 seconds.

Problem	LED		Possible cause	Remedy
	"ST"	"HV-ST"		
No voltage at signal output	Off	Off	No supply	Switch on supply
Measuring signal unstable	Lights up green	Lights up green	Gauge contaminated	Replace ionization chamber or complete measurement chamber
Voltage at signal output < 4.82 V (< 5×10^{-4} hPa) not possible.	Lights up yellow	Flashes green	Gas discharge has not ignited	Wait until the gas discharge ignites (approx. 5 minutes at a pressure of 10^{-9} hPa).
Voltage at signal output constantly > 5.6 V (> 0.01 hPa)	Lights up green	Off	Pirani zero point shift	Perform a manual HV calibration
Voltage at signal output constantly > 9.5 V (sensor error)	Lights up red	Off	Pirani faulty	Replace complete measurement chamber
	Flashes red	Off	EEPROM error	Switch off the gauge and then switch on again after 5 seconds (reset) Replace gauge
Signal constant with approx. 4.82 V (5×10^{-4} hPa).	Lights up green	Lights up green	Measurement chamber heavily contaminated	Replace complete measurement chamber

Tbl. 15: Malfunctions PKR

Problem	LED		Possible cause	Remedy
	"ST"	"HV-ST"		
No voltage at signal output	Off	Off	No supply	Switch on supply
Measuring signal unstable	Lights up green	Lights up green	Gauge contaminated	Replace ionization chamber or complete measurement chamber
Voltage at signal output 0.15 V (sensor error)	Lights up yellow	Off	Overpressure in the measurement chamber	Pump down to < 1×10^{-2} hPa, switch off the gauge and then switch on again (reset)
Voltage at signal output 1.2 V (underrange)	Lights up yellow	Flashes green	Gas discharge has not ignited	Wait until the gas discharge ignites (approx. 5 minutes at pressure of 10^{-9} hPa).

Problem	LED		Possible cause	Remedy
	"ST"	"HV-ST"		
Voltage at signal output constantly < 0.3 V	Flashes red	Off	EEPROM error	Switch off the gauge and then switch on again after 5 seconds (reset) Replace gauge
Signal constant with approx. 7.2 V ($5 \times 10^{-4} \text{ hPa}$).	Lights up green	Lights up green	Measurement chamber heavily contaminated	Replace complete measurement chamber

Tbl. 16: Malfunctions IKR

10 Shipping

WARNING

Risk of poisoning from contaminated products

Where products that contain harmful substances are shipped for maintenance or repair purposes, the safety of service personnel is at risk.

- ▶ Comply with the instructions for safe shipping.

Shipping the product safely



Decontamination subject to charge

Pfeiffer Vacuum decontaminates products not clearly declared "Free of contamination" at your expense.

1. Do not ship microbiological, explosive or radioactively contaminated products.
2. Observe the shipping guidelines for the participating countries and transport companies.
3. Highlight any potential dangers on the outside of the packaging.
4. Download the declaration of contamination. ([Pfeiffer Vacuum Service](#)).
5. Always enclose a completed declaration of contamination.

11 Disposal

⚠ WARNING

Health hazard through poisoning from toxic contaminated components or devices

Toxic process media result in contamination of devices or parts of them. During maintenance work, there is a risk to health from contact with these poisonous substances. Illegal disposal of toxic substances causes environmental damage.

- ▶ Take suitable safety precautions and prevent health hazards or environmental pollution by toxic process media.
- ▶ Decontaminate affected parts before carrying out maintenance work.
- ▶ Wear protective equipment.

⚠ CAUTION

Health hazard caused by environmentally hazardous substances

Products, operating fluid, electric components, calibration gas residues (for example from test leaks) or similar pose health hazards.

- ▶ Dispose of the environmentally hazardous substances in accordance with local regulations.
- ▶ Dispose of calibration gas and test leaks in accordance with local regulations.

Dividing components

- ▶ After disassembly, divide the components into the following categories with regard to disposal:
 - contaminated components **that have** contact with process gases
 - non-contaminated components **that have no** contact with process gases

Disposal of contaminated components that have contact with process gases

1. Dispose of the substances in a safe manner in accordance with the locally applicable regulations if the process gases used were contaminated, e.g. radioactive, toxic, caustic or a microbiological manner.
2. Observe the environment and safety provisions of the respective country.

Disposal of components that do not have contact with process gases

1. Separate the components according to their type of material:
 - electronic components
 - electrical components
 - battery and rechargeable batteries
 - mechanical components
2. Recycle the components.
3. Dispose of the substances in a safe manner according to locally applicable regulations.
4. Observe the environment and safety provisions of the respective country.

12 Service solutions from Pfeiffer Vacuum

We offer first class service

Long vacuum component service life, coupled with low downtimes, are clear expectations that you have of us. We satisfy your needs with capable products and outstanding service.

We are consistently striving to perfect our core competence, service for vacuum components. And our service is far from over once you've purchased a product from Pfeiffer Vacuum. It often enough really just begins then. In proven Pfeiffer Vacuum quality, of course.

Our professional sales engineers and service technicians stand ready to provide hands-on support to you worldwide. Pfeiffer Vacuum offers a complete portfolio of service offerings, ranging from genuine spare parts right through to service agreements.

Take advantage of Pfeiffer Vacuum Service

Whether for preventative on-site service from our field service, fast replacement with as-new replacement products or repair in a Service Center close to you; you have various options for upholding your equipment availability. Detailed information and addresses can be found on our website in the Pfeiffer Vacuum Service section.

Advice on the optimum solution is available from your Pfeiffer Vacuum contact partner. For quick and smooth handling of the service process, we recommend the following steps:

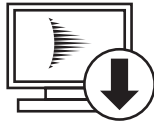

1. Download the current form templates.
 - Declaration of Service Request
 - Service Request
 - Declaration of Contamination



- a. Dismantle all accessories and keep them (all external mounted parts as valve, inlet screen, etc.).
 - b. Drain the operating fluid/lubricant as necessary.
 - c. Drain the cooling medium as necessary.
2. Fill out the service request and the declaration of contamination.



3. Send the forms via email, fax or post to your local Service Center.



4. You will receive a response from Pfeiffer Vacuum.

PFEIFFER VACUUM

Sending of contaminated products

No units will be accepted if they are contaminated with micro-biological, explosive or radioactive substances. If products are contaminated or if the declaration of contamination is missing, Pfeiffer Vacuum will contact the customer before starting maintenance. In addition, depending on the product and the level of contamination **additional decontamination costs** may be required.

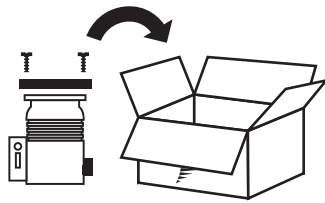

5. Prepare the product for transport in accordance with the details in the declaration of contamination.
 - a) Neutralize the product with nitrogen or dry air.
 - b) Close all openings with airtight blank flanges.
 - c) Seal the product in appropriate protective film.
 - d) Only pack the product in suitable, stable transport containers.
 - e) Observe the applicable transport conditions.

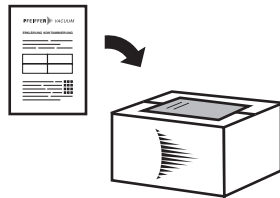

6. Affix the declaration of contamination to the **outside** of the packaging.

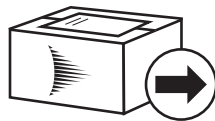

7. Then send your product to your local [Service Center](#).

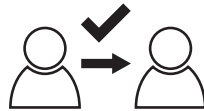

8. You will receive a confirmation message/a quotation from Pfeiffer Vacuum.

PFEIFFER VACUUM

For all service orders, our [General Terms and Conditions of Sales and Supply](#) and [General Terms and Conditions of Repair and Maintenance](#) apply to vacuum equipment and components.

13 Ordering information

13.1 Ordering parts

Ordering spare parts, accessories or optional components

- ▶ Always specify the following details when ordering spare parts, accessories or optional components:
 - all details according to the rating plate
 - description and order number according to the parts list

13.2 Spare parts

The complete measurement chamber (replacement sensor) is preassembled.

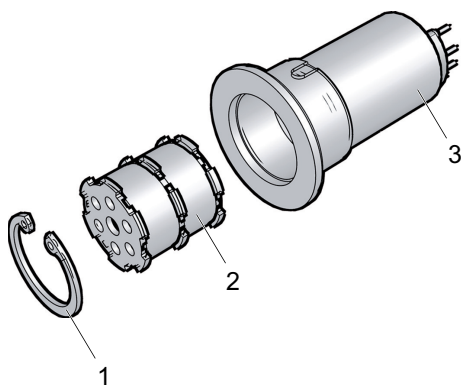

Fig. 21: Complete measurement chamber (replacement sensor)

- 1 Circlip
- 2 Ionization chamber
- 3 Measurement chamber

Description		Order number	
Ignition aid set (10 x)		BN 845 995 -T	
Mounting tool for ignition aid		PT 120 316 -T	
Ionization chamber (stainless steel)		PT 120 312 -T	
Complete measurement chamber	PKR 36x	DN 25 ISO-KF	PT 120 302 -T
		DN 40 ISO-KF	PT 120 306 -T
		DN 40 CF-F	PT 120 310 -T
	PKR 36x C	DN 25 ISO-KF	PT 120 303 -T
		DN 40 ISO-KF	PT 120 307 -T
		DN 40 CF-F	PT 120 311 -T
	IKR 36x	DN 25 ISO-KF	PT 120 300 -T
		DN 40 ISO-KF	PT 120 304 -T
		DN 40 CF-F	PT 120 308 -T
	IKR 36x C	DN 25 ISO-KF	PT 120 301 -T
		DN 40 ISO-KF	PT 120 305 -T
		DN 40 CF-F	PT 120 309 -T

Tbl. 17: Spare parts

13.3 Accessories



Installation and operation of accessories

Pfeiffer Vacuum offers a series of special, compatible accessories for its products.

- Information and ordering options for [ActiveLine accessories](#) can be found online.

Description	Order number
Measurement cable, 3 m	PT 448 250 -T
Measurement cable, 6 m	PT 448 251 -T
Measurement cable, 10 m ⁴⁾	PT 448 252 -T
Mating connector	B 4707 283 MA
Centering ring with protection filter, FPM/stainless steel, DN 25 ISO-KF	PF 117 225 -T
Centering ring, with poral filter, FPM/stainless steel, DN 40 ISO-KF	PF 117 240 -T

4) Further cable lengths are available up to 100 m.

14 Technical data and dimensions

Parameter	Value
Measuring range (air, N ₂)	1 × 10 ⁻⁹ up to 1000 hPa
Maximum pressure (absolute)	10 000 hPa, limited to inert gases and temperatures < 55 °C
Burst pressure (absolute)	> 13 000 hPa
Measuring principle	Pirani/cold cathode
Accuracy (N ₂)	approx. ±30 % within the range 1 × 10 ⁻⁸ up to 100 hPa
	approx. ±50 % within the range 100 to 1000 hPa
Repeatability (N ₂)	approx. ±5 % within the range 1 × 10 ⁻⁸ up to 100 hPa

Tbl. 18: Measuring and pressure values PKR

Parameter	Value
Measuring range (air, N ₂)	1 × 10 ⁻⁹ up to 1 × 10 ⁻² hPa
Maximum pressure (absolute)	10 000 hPa, limited to inert gases and temperatures < 55 °C
Burst pressure (absolute)	> 13 000 hPa
Measuring principle	Cold cathode
Accuracy (N ₂)	approx. ±30 % within the range 1 × 10 ⁻⁸ up to 1 × 10 ⁻² hPa
Repeatability (N ₂)	approx. ±5 % within the range 1 × 10 ⁻⁸ up to 1 × 10 ⁻² hPa

Tbl. 19: Measuring and pressure values IKR

Parameter	Value	
Output signal (measuring signal)	Voltage range	approx. 0 V to approx. +10.5 V
	Measuring range	+1.397 to +8.6 V DC
	Error signal	+9.5 to +10.5 V
	Relation voltage-pressure	logarithmic, rise 0.6 V / decade
Output impedance	2 × 4.7 Ω, short circuit-proof	
Load impedance (minimum load)	≥ 10 kΩ, short circuit-proof	
Response time		pressure-dependent
	p > 10 ⁻⁶ hPa	< 100 ms
	p = 10 ⁻⁶ up to 10 ⁻⁸ hPa	approx. 1 s
Gauge identification	Solely Pirani operation	Resistance 11.1 kΩ against supply earth
	Combined Pirani/cold cathode operation	Resistance 9.1 kΩ against supply earth
	Conditions to be complied with in this regard:	
	<ul style="list-style-type: none"> • The polarity of pin 1 must always be positive against supply earth. • Measurements with constant current: Measurement current within the range 0.2 to 0.3 mA • Measurements with constant voltage: Measurement voltage within the range 2 to 3 V 	

Parameter	Value	
Supply voltage	Class 2 / LPS	
	at gauge ⁵⁾	14.5 to 30.0 V DC
	Ripple	max. 1 V _{pp}
Ignition voltage (in the measurement chamber)	≤ 4.5 kV	
Operating voltage (in the measurement chamber)	≤ 3.3 kV	
Operating current (in the measurement chamber)	PKR 360: low current	
	PKR 361: high current	
Power input	≤ 2 W	
Fuse (to be connected in series) ⁶⁾	≤ 1 AT	
Connection (electrical)	Hirschmann GO 6 (6-pin, pins)	
Measurement cable	5-pin, including shielding	
Cable length	max. 75 m (0.14 mm ² / conductor)	
	max. 100 m (0.34 mm ² / conductor)	
	max. 300 m (1.0 mm ² / conductor)	
Earthing concept	(see chapter "Establishing the electrical connection", page 23)	
	Vacuum connection and signal ground	connected with 10 kΩ (potential difference ≤ 16 V)
	Supply earth and signal earth	arranged separately, differential measurement recommended

Tbl. 20: Electrical data PKR

Parameter	Value	
Output signal (measuring signal)	Voltage range	approx. 0 V to approx. +10.5 V
	Measuring range	+1.5 to +8.5 V DC
	Error signal	< 0.5 V (no supply)
	Relation voltage-pressure	logarithmic, rise 1 V / decade
Output impedance	2 × 4.7 Ω, short circuit-proof	
Load impedance (minimum load)	≥ 10 kΩ, short circuit-proof	
Response time		pressure-dependent
	p > 10 ⁻⁶ hPa	< 100 ms
	p = 10 ⁻⁶ Up to 10 ⁻⁸ hPa	approx. 1 s
Gauge identification	Resistance 5.1 kΩ against supply earth	
	Conditions to be complied with in this regard: <ul style="list-style-type: none"> • The polarity of pin 1 must always be positive against supply earth. • Measurements with constant current: Measurement current within the range 0.2 to 0.3 mA • Measurements with constant voltage: Measurement voltage within the range 2 to 3 V 	

5) The minimum voltage for the supply unit must be increased proportional to the cable length.

6) Pfeiffer Vacuum measuring and control equipment complies with this requirement.

Parameter	Value	
Supply voltage	Class 2 / LPS	
	at gauge ⁷⁾	14.5 to 30.0 V DC
	Ripple	max. 1 V _{pp}
Ignition voltage (in the measurement chamber)	≤ 4.5 kV	
Operating voltage (in the measurement chamber)	≤ 3.3 kV	
Operating current (in the measurement chamber)	IKR 360: low current	
	IKR 361: high current	
Power input	≤ 2 W	
Fuse (to be connected in series) ⁸⁾	≤ 1 AT	
Connection (electrical)	Hirschmann GO 6 (6-pin, pins)	
Measurement cable	5-pin, including shielding	
Cable length	max. 75 m (0.14 mm ² / conductor)	
	max. 100 m (0.34 mm ² / conductor)	
	max. 300 m (1.0 mm ² / conductor)	
Earthing concept	(see chapter “Establishing the electrical connection”, page 23)	
	Vacuum connection and signal ground	connected with 10 kΩ (potential difference ≤ 16 V)
	Supply earth and signal earth	arranged separately, differential measurement recommended

Tbl. 21: Electrical data IKR

Parameter	Value
Internal volume	approx. 19.9 cm ³ (DN 25 ISO-KF)
	approx. 20.9 cm ³ (DN 40 ISO-KF)
	approx. 25.2 cm ³ (DN 40 CF-F)
Weight	< 280 g (DN 25 ISO-KF)
	< 320 g (DN 40 ISO-KF)
	< 570 g (DN 40 CF-F)

Tbl. 22: Internal volume and weight

Parameter	Value	
Relative humidity (for 30 days of the year)	1 × 10 ⁻⁸ up to 1 × 10 ⁻² hPa	≤ 70 % (non-condensing)
	1 × 10 ⁻⁷ up to 1 × 10 ⁻² hPa	≤ 95 % (non-condensing)
Mounting orientation	Arbitrary	
Use	Only in indoor areas	
Installation altitude max.	6000 m MSL	
Protection category	IP40	

Tbl. 23: Ambient conditions

7) The minimum voltage for the supply unit must be increased proportional to the cable length.
 8) Pfeiffer Vacuum measuring and control equipment complies with this requirement.

Parameter	Value
Operation	5 to 55 °C
Pirani filament (PKR only)	120 °C
Storage	-40 to +70 °C
Bake out	≤ 150 °C ⁹⁾

Tbl. 24: Temperatures

Parameter	Value
Flange	Stainless steel (1.4435)
Measurement chamber	Stainless steel (1.4435)
Pirani filament (PKR only)	Tungsten (W)
Feedthrough (insulation)	Ceramic (Al ₂ O ₃), glass
Feedthrough (ring)	Stainless steel (1.4435)
Feedthrough (anode)	Molybdenum (Mo)
Feedthrough (pin)	Nickel alloy (Ni)
Feedthrough (PKR 36x C, IKR 36x C)	Ceramic coated
Ionization chamber	Stainless steel (1.4301, 1.4016)
Ignition aid	Stainless steel (1.4310)

Tbl. 25: Material against vacuum

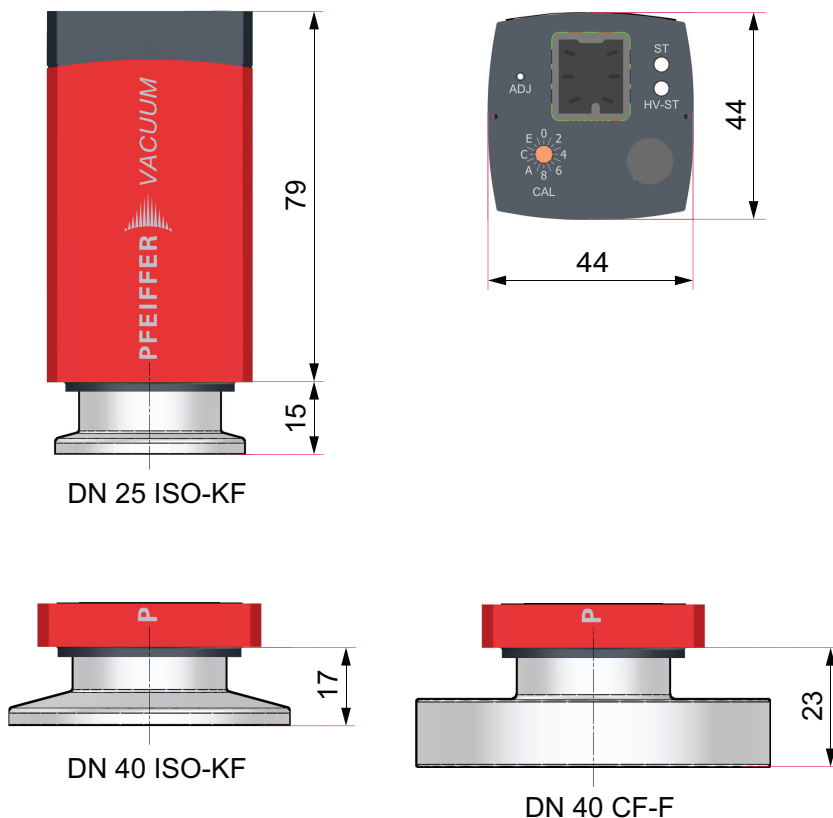

Fig. 22: Dimensions

Dimensions in mm.

9) Without electronic unit

15 Appendix

15.1 Units of pressure

Unit	mbar	bar	Pa	hPa	kPa	Torr / mm Hg
mbar	1	$1 \cdot 10^{-3}$	100	1	0.1	0.75
bar	1000	1	$1 \cdot 10^5$	1000	100	750
Pa	0.01	$1 \cdot 10^{-5}$	1	0.01	$1 \cdot 10^{-3}$	$7.5 \cdot 10^{-3}$
hPa	1	$1 \cdot 10^{-3}$	100	1	0.1	0.75
kPa	10	0.01	1000	10	1	7.5
Torr / mm Hg	1.33	$1.33 \cdot 10^{-3}$	133.32	1.33	0.133	1

1 Pa = 1 N/m²

Tbl. 26: Units of pressure and their conversion

15.2 Gas throughputs

Unit	mbar l/s	Pa m ³ /s	sccm	Torr l/s	atm cm ³ /s
mbar l/s	1	0.1	59.2	0.75	0.987
Pa m ³ /s	10	1	592	7.5	9.87
sccm	$1.69 \cdot 10^{-2}$	$1.69 \cdot 10^{-3}$	1	$1.27 \cdot 10^{-2}$	$1.67 \cdot 10^{-2}$
Torr l/s	1.33	0.133	78.9	1	1.32
atm cm ³ /s	1.01	0.101	59.8	0.76	1

Tbl. 27: Gas throughputs and their conversion



Intertek
3103457

ETL LISTED

The products PKR 360, PKR 360 C, PKR 361 and PKR 361C

- conform to the UL standard
UL 61010-1.

- are certified to the CAN/CSA standard
CAN/CSA C22.2 No. 61010-1-12.



ETL LISTED

The products IKR 360, IKR 360 C, IKR 361 and IKR 361C

- conform to the UL standard
UL 61010-1.

- are certified to the CAN/CSA standard
CAN/CSA C22.2 No. 61010-1-12.

Declaration of Conformity PKR

We hereby declare that the product cited below satisfies all relevant provisions of the following **EU Directives**:

- **Electromagnetic compatibility 2014/30/EU**
- **Restriction of the use of certain hazardous substances 2011/65/EU**

Pirani/cold cathode gauge

PKR 360, PKR 360 C, PKR 361, PKR 361 C

Harmonized standards and applied national standards and specifications:

DIN EN 61000-6-2:2006-03

DIN EN 61000-6-3:2011-09

DIN EN 61010-1:2011-07

DIN EN 61326-1:2013-07

Signature:



Pfeiffer Vacuum GmbH
Berliner Straße 43
35614 Aßlar
Germany

(Dr. Ulrich von Hülsen)
Managing Director

Aßlar, 2018-06-14



Declaration of Conformity IKR

We hereby declare that the product cited below satisfies all relevant provisions of the following **EU Directives**:

- **Electromagnetic compatibility 2014/30/EU**
- **Restriction of the use of certain hazardous substances 2011/65/EU**

Cold cathode gauge

IKR 360, IKR 360 C, IKR 361, IKR 361 C

Harmonized standards and applied national standards and specifications:

DIN EN 61000-6-2:2006-03

DIN EN 61000-6-3:2011-09

DIN EN 61010-1:2011-07

DIN EN 61326-1:2013-07

Signature:



Pfeiffer Vacuum GmbH
Berliner Straße 43
35614 Aßlar
Germany

(Dr. Ulrich von Hülsen)
Managing Director

Aßlar, 2018-06-05





VACUUM SOLUTIONS FROM A SINGLE SOURCE

Pfeiffer Vacuum stands for innovative and custom vacuum solutions worldwide, technological perfection, competent advice and reliable service.

COMPLETE RANGE OF PRODUCTS

From a single component to complex systems:

We are the only supplier of vacuum technology that provides a complete product portfolio.

COMPETENCE IN THEORY AND PRACTICE

Benefit from our know-how and our portfolio of training opportunities!

We support you with your plant layout and provide first-class on-site service worldwide.

ed. B - Date 1905 - P/N:BG5164BEN



Are you looking for a
perfect vacuum solution?
Please contact us

Pfeiffer Vacuum GmbH
Headquarters • Germany
T +49 6441 802-0
info@pfeiffer-vacuum.de

www.pfeiffer-vacuum.com

PFEIFFER  **VACUUM**