

**Duo 65 M, 3-phase motor, 3TF,
230/400 V, 50 Hz | 265/460 V, 60 Hz**

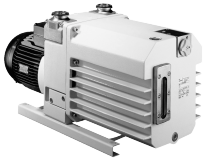

Similar Image

Duo 65 M, 3-phase motor, 3TF, 230/400 V, 50 Hz | 265/460 V, 60 Hz

- Dual-stage, high-performance rotary vane pump with a pumping speed up to 70 m³/h
- With 3-phase motor
- With temperature sensor (3TF) for optimum motor protection
- Integrated gas ballast and HV safety valve
- For all low and medium vacuum applications
- Magnetically coupled
- Special feature: Various motor voltages for worldwide employment

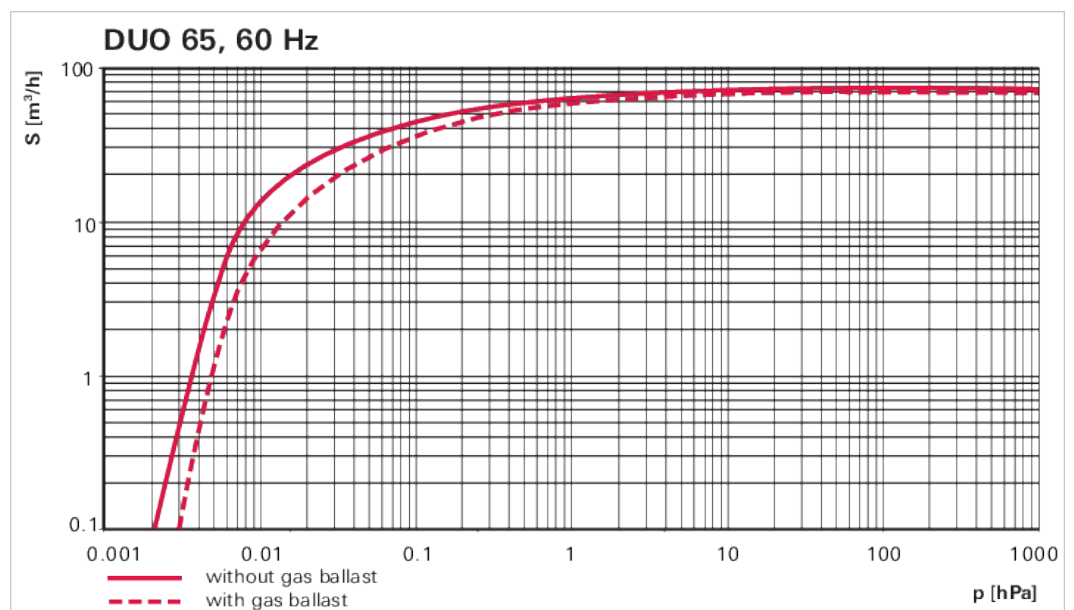
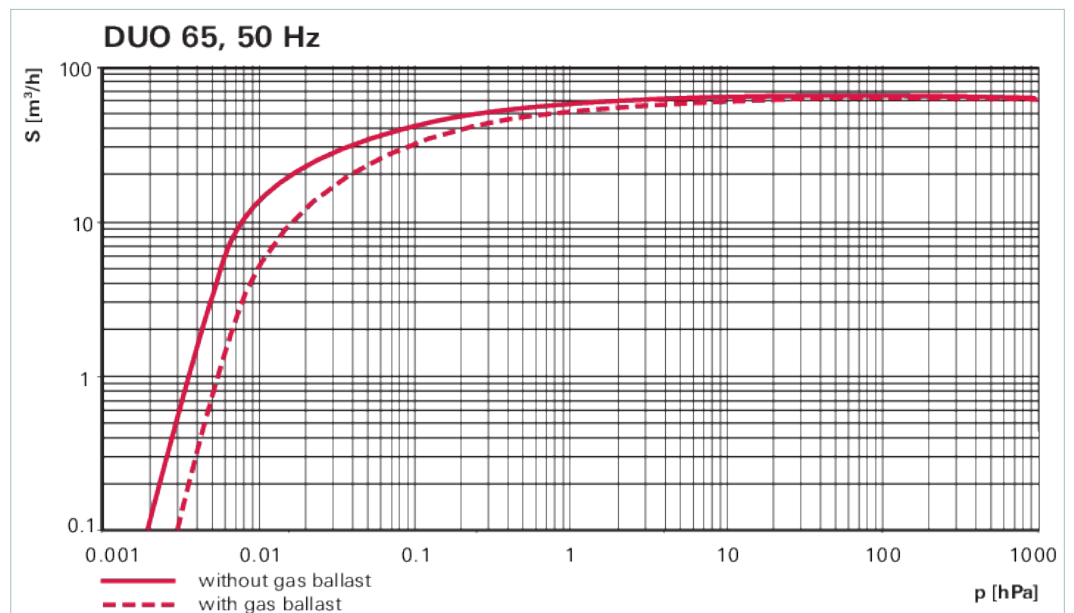

Dimensions

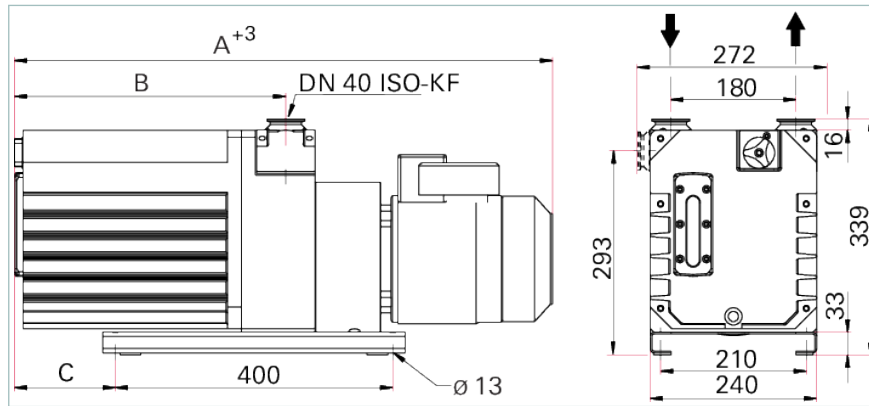

A	771 mm
B	392 mm
C	146 mm

Technical Data	Duo 65 M, 3-phase motor, 3TF, 230/400 V, 50 Hz 265/460 V, 60 Hz
Ambient temperature	12-40 °C 53.6-104 °F 285-313 K
Cooling method, standard	Air
Dimensions (L x W x H)	771 x 240 x 340 mm 30.35 x 9.45 x 13.39 inch
Emission sound pressure level without gas ballast at 50 Hz	61 dB(A)
Exhaust pressure, max.	1,500 hPa 1,125 Torr 1,500 mbar
Exhaust pressure, min.	250 hPa 187.5 Torr 250 mbar
Flange (in)	DN 40 ISO-KF
Flange (out)	DN 40 ISO-KF
Leak rate magnetic coupling	$1 \cdot 10^{-7}$ Pa m ³ /s
Leak rate safety valve	$1 \cdot 10^{-5}$ Pa m ³ /s
Magnetic coupling	Yes
Mains cable	No
Mains requirement: voltage (range)	± 5 %
Mains requirement: voltage 50 Hz	230/400 V
Mains requirement: voltage 60 Hz	265/460 V
Motor protection	3TF
Motor version	3-ph motor
Operating fluid	P3
Operating fluid filling	4.2 l
Protection category	IP55
Pumping speed at 50 Hz	62 m ³ /h
Pumping speed at 60 Hz	70 m ³ /h
Rated power 50 Hz	1.5 kW
Rated power 60 Hz	1.8 kW
Rotation speed at 50 Hz	1,500 rpm 1,500 min ⁻¹
Rotation speed at 60 Hz	1,800 rpm 1,800 min ⁻¹
Sealing gas	false
Switch New	No
Ultimate pressure with gas ballast	$3 \cdot 10^{-3}$ hPa $2.25 \cdot 10^{-3}$ Torr $3 \cdot 10^{-3}$ mbar
Ultimate pressure without gas ballast	$2 \cdot 10^{-3}$ hPa $1.5 \cdot 10^{-3}$ Torr $2 \cdot 10^{-3}$ mbar
Weight: with motor	78 kg 171.96 lb

Order number

Duo 65 M

PK D46 035

Accessories	
Connections Adapters for OktaLine to Rotary Vane Pumps	
Adapter Uno/Duo 35/65 for Okta 250	PK 223 787 -T
Adapter Uno/Duo 35/65 for Okta 300/500/600/800/1000	PK 224 629 -T
Flanges/Ports Blank flanges	
Blank flange gas ballast valve with O-ring and screws	PK 223 797 -T
Heating Heating rods for zeolite traps (ZFO)	
Heating rod for ZFO 040, 220 V, 50/60 Hz	PK Z90 020 A
Monitoring Operations monitoring units	
Operations monitoring unit 1 for Duo 35/65	PK 223 718 AU
Operations monitoring unit 3 for Duo 35/65, Duo 125/255	PK 223 739 AU
Monitoring Pressure switches	
Oil pressure switch for Duo 35/65; Duo 35/65 MC	PK 223 720 -U
Oil pressure switch for Duo 35/65 with OFC/OFM	PK 223 741 -U
Protection Activated carbon filters	
FAK 040, activated carbon filter	PK Z30 008
Protection Catalyzer traps	
URB 040, catalytic trap, 230 V	PT U10 260
URB 040, catalytic trap, 115 V	PT U10 261
Protection Cold traps	
KLF 040, cold trap	PK Z80 008
Protection Condensate separators	
KAS 40, condensate separator for pumping speeds up to 120 m ³ /h	PK Z10 008
Protection Dust separators/Inlet particle filters	
SAS 40, dust separator, DN 40 ISO-KF, polyester filter	PK Z60 510
Protection Flushing devices	
Gas flushing device for Duo 35 and Duo 65	PK 007 300 -T
Protection Motor protection	
PTC-resistor tripping device	P 4768 052 FQ
Protection Oil filters	
OFC 35/65, chemical oil filter	PK Z90 320
OFM 35/65, mechanical oil filter	PK Z90 321
External oil filter DE 1, 230 V, 50 Hz	068990
External oil filter DE 1, 110 V	068991
External oil filter DE 2, 230 V, 50 Hz	104374
External oil filter DE 2, 110 V, 50 Hz/60 Hz	104375
Protection Oil mist eliminators	
OME 40 M, oil mist filter for Duo 35/65, Duo 35/65 M	PK Z40 150
OME 40 MR, oil mist filter with oil return to pump for Duo 35/65, Duo 35/65 M	PK Z40 151
Oil mist eliminator OME 40 S	104887
Protection Oil return units from oil mist eliminators	
Oil return unit ODK from OME 40 M/C to Duo 35/65	PK 005 950 -T
Protection Soft starters	
Soft starter 3.6 A	P 4769 001
Soft starter 6.5 A	P 4769 003
Soft starter 9 A	P 4769 004

Accessories	
Protection Sorption traps, corrosive version	
Sorption trap ST 40, 115 V (without adsorbent charge)	104371
Sorption trap ST 40, 230 V (without adsorbent charge)	053380
Valves Gas ballast conversion kits	
Gas ballast valve-conversion kit corrosive version with Hose nozzle	PK 223 713 -U
Valves Gas ballast valves, magnetic	
Gas ballast valve-conversion kit corrosive version with magnetic valve	PK 223 717 -U
Consumables	
P3, mineral oil, 1 l	PK 001 106 -T
P3, mineral oil, 5 l	PK 001 107 -T
P3, mineral oil, 20 l	PK 001 108 -T
D1, synthetic diester based oil, 1 l	PK 005 875 -T
D1, synthetic diester based oil, 5 l	PK 005 876 -T
D1, synthetic diester based oil, 20 l	PK 005 877 -T

VACUUM SOLUTIONS FROM A SINGLE SOURCE

Pfeiffer Vacuum stands for innovative and custom vacuum solutions worldwide, technological perfection, competent advice and reliable service.

COMPLETE RANGE OF PRODUCTS

From a single component to complex systems:

We are the only supplier of vacuum technology that provides a complete product portfolio.

COMPETENCE IN THEORY AND PRACTICE

Benefit from our know-how and our portfolio of training opportunities!

We support you with your plant layout and provide first-class on-site service worldwide.

Are you looking for a
perfect vacuum solution?
Please contact us:

Pfeiffer Vacuum GmbH
Headquarters · Germany
T +49 6441 802-0
info@pfeiffer-vacuum.de

www.pfeiffer-vacuum.com

All data subject to change without prior notice.

PFEIFFER  **VACUUM**