

Duo 20 M, 1-phase motor, 100–110 V, 50 Hz | 100–120 V, 60 Hz



Similar Image

Duo 20 M, 1-phase motor, 100–110 V, 50 Hz | 100–120 V, 60 Hz

- Dual-stage, high-performance rotary vane pump with a pumping speed up to 24 m³/h
- With Single-phase motor
- Integrated gas ballast and HV safety valve
- For all low and medium vacuum applications
- Magnetically coupled
- Special feature: Various motor voltages for worldwide employment

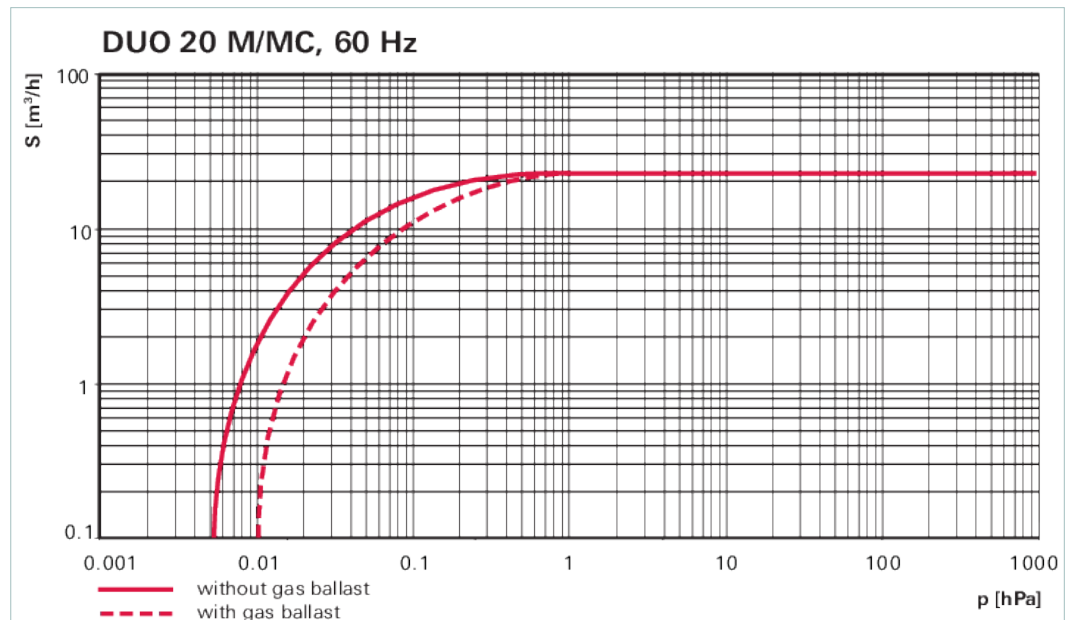
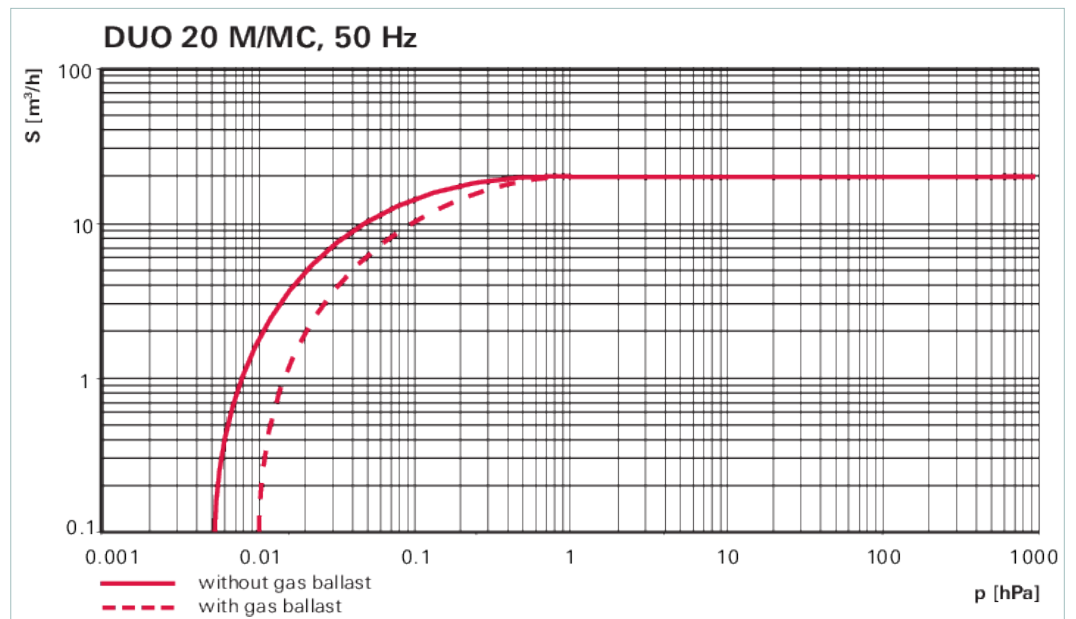

Dimensions

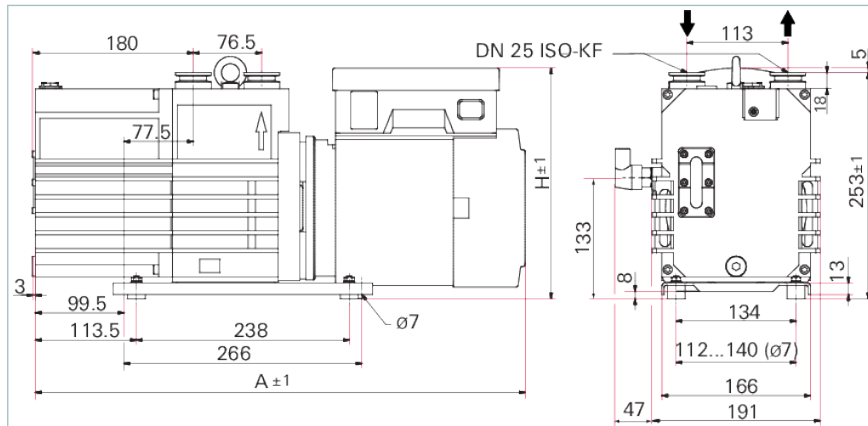

A	551 mm
H	262 mm

Technical Data	Duo 20 M, 1-phase motor, 100–110 V, 50 Hz 100–120 V, 60 Hz
Ambient temperature	12–40 °C 53.6–104 °F 285–313 K
Cooling method, standard	Air
Emission sound pressure level without gas ballast at 50 Hz	57 dB(A)
Exhaust pressure, max.	1,500 hPa 1,125 Torr 1,500 mbar
Exhaust pressure, min.	250 hPa 187.5 Torr 250 mbar
Flange (in)	DN 25 ISO-KF
Flange (out)	DN 25 ISO-KF
Leak rate safety valve	$1 \cdot 10^{-5}$ Pa m ³ /s
Magnetic coupling	Yes
Mains cable	Yes
Mains requirement: voltage (range)	±5 %
Mains requirement: voltage (selectable)	200–230, 50 Hz; 200–240, 60 Hz V
Mains requirement: voltage 50 Hz	100 – 110 V
Mains requirement: voltage 60 Hz	100 – 120 V
Motor version	1-ph motor
Operating fluid	P3
Operating fluid filling	1.1 l
Protection category	IP54
Pumping speed at 50 Hz	20 m ³ /h
Pumping speed at 60 Hz	24 m ³ /h
Rated power 50 Hz	0.75 kW
Rated power 60 Hz	0.9 kW
Rotation speed at 50 Hz	1,500 rpm 1,500 min ⁻¹
Rotation speed at 60 Hz	1,800 rpm 1,800 min ⁻¹
Switch New	Yes
Ultimate pressure with gas ballast	$4 \cdot 10^{-3}$ hPa $3 \cdot 10^{-3}$ Torr $4 \cdot 10^{-3}$ mbar
Ultimate pressure without gas ballast	$2 \cdot 10^{-3}$ hPa $1.5 \cdot 10^{-3}$ Torr $2 \cdot 10^{-3}$ mbar
Weight	44 kg 97 lb

Order number	
Duo 20 M	PK D63 707

Accessories	
Monitoring Pressure switches	
Oil pressure switch for Duo 5/10/20 M and Penta 20/35	PK 196 484 -T
Protection Activated carbon filters	
FAK 025, activated carbon filter	PK Z30 006
Protection Catalyzer traps	
URB 025, catalytic trap, 230 V	PT U10 760
URB 025, catalytic trap, 115 V	PT U10 761
Protection Cold traps	
KLF 025, cold trap	PK Z80 006
Protection Condensate separators	
KAS 25 L, condensate separator for pumping speeds up to 35 m ³ /h	PK Z10 033
Protection Oil mist eliminators	
OME 25 ML, oil mist filter for pumping speeds of up to 30 m ³ /h	PK Z40 158
Oil mist eliminator OME 25 S	104200
Protection Oil return units from oil mist eliminators	
Oil return unit ODK from OME 16 M to Duo 5 M, from OME 25 M to Duo 10 M, from OME 25 ML in Duo 20 M	PK 196 172 -T
Protection Sorption traps	
Sorption trap ST 25 S	104107
Rotary vane pumps - for inlet side	
SAS 25, dust separator, DN 25 ISO-KF, polyester filter	PK Z60 508

VACUUM SOLUTIONS FROM A SINGLE SOURCE

Pfeiffer Vacuum stands for innovative and custom vacuum solutions worldwide, technological perfection, competent advice and reliable service.

COMPLETE RANGE OF PRODUCTS

From a single component to complex systems:

We are the only supplier of vacuum technology that provides a complete product portfolio.

COMPETENCE IN THEORY AND PRACTICE

Benefit from our know-how and our portfolio of training opportunities!

We support you with your plant layout and provide first-class on-site service worldwide.

Are you looking for a
perfect vacuum solution?
Please contact us:

Pfeiffer Vacuum GmbH
Headquarters · Germany
T +49 6441 802-0
info@pfeiffer-vacuum.de

www.pfeiffer-vacuum.com

All data subject to change without prior notice.

PFEIFFER  **VACUUM**