

4

3

2

DWG. NO. 300L-XX-8S SH. 2 REV. A

THIS DRAWING HAS BEEN GENERATED AND IS MAINTAINED BY PRO/ENGINEER CAD SYSTEM.

D

D

C

C

B

B

A

A

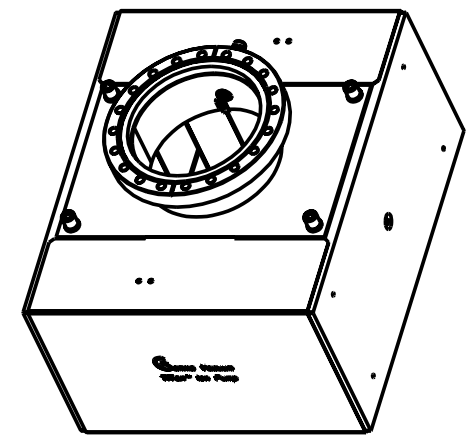
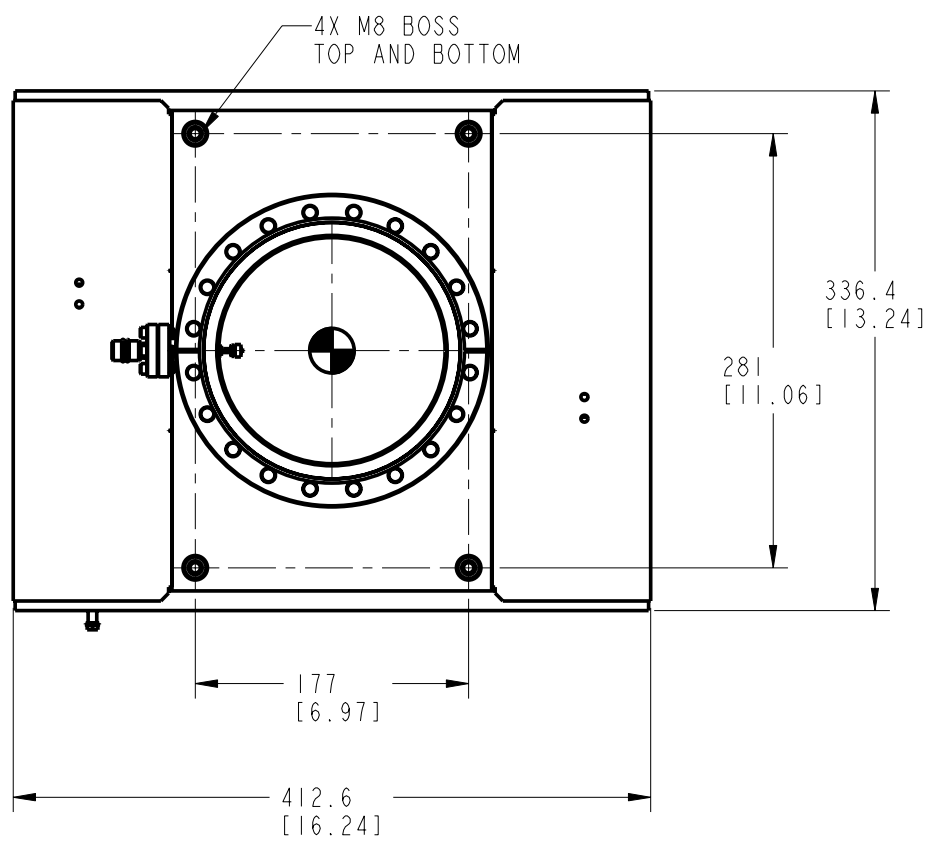

SCALE 0.200

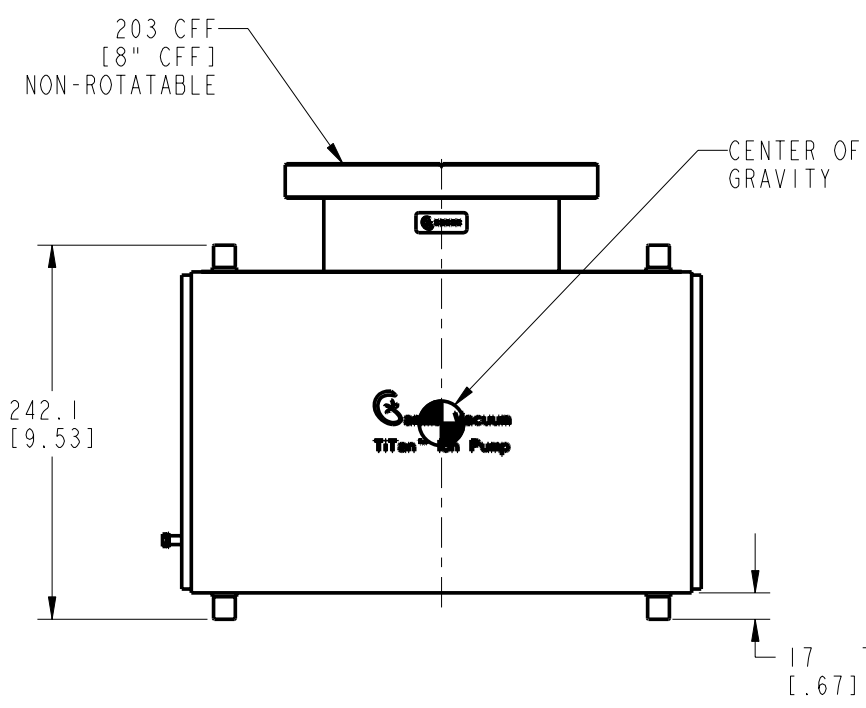
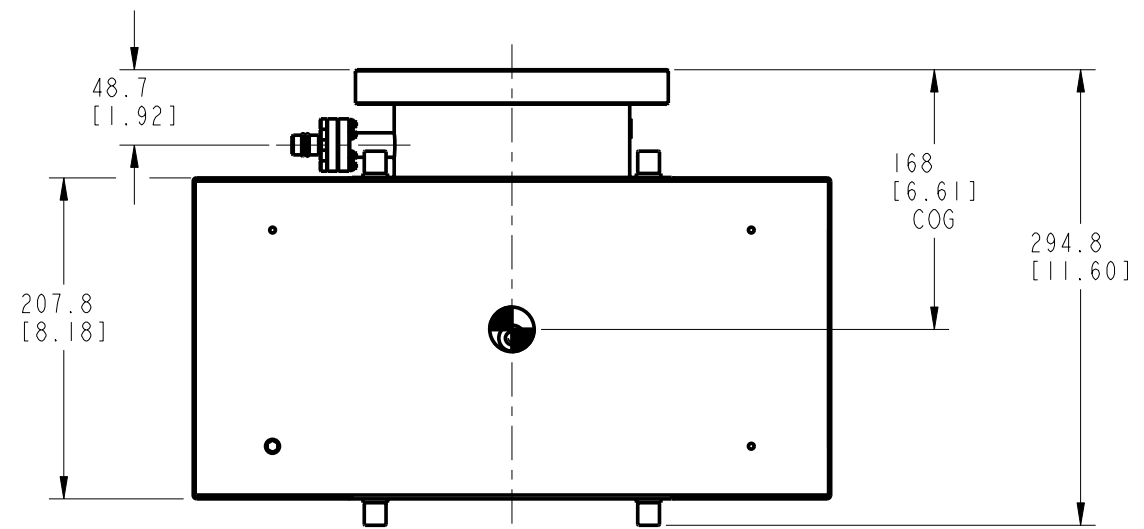

ALL DIMENSIONS ARE FOR REFERENCE ONLY

|   |   |   |  |
|---|---|---|--|
| <b>METRIC</b><br>THIRD ANGLE PROJECTION<br> | UNLESS OTHERWISE SPECIFIED<br>DIMENSIONS ARE IN MILLIMETERS<br>SURFACE ROUGHNESS IN MICROMETERS<br>TOLERANCES:<br>LINEAR ±0.13<br>HOLES ±0.13<br>ANGULAR (±)<br>MACHINED 0.5°<br>FORMED 1°<br>CHAMFER 5° 1.6<br>MACHINED SURFACES<br>BREAK SHARP EDGES:<br>R0.2 OR 45° 0.2 MAX.<br>INTERNAL MACH. CORNER R.4 MAX. | DWN R GOLLA DATE 6-14-06<br>CHR MHC DATE 6-14-06<br>APPV RDG DATE 6-14-06<br>RI R GOLLA<br>TOLERANCING AND DIMENSIONING PER ANSI Y14.5M-1982<br>THIS DRAWING CONTAINS PROPRIETARY INFORMATION AND ANY REPRODUCTION, DISCLOSURE OR USE OF THIS DRAWING IS EXPRESSLY PROHIBITED EXCEPT AS GAMMA VACUUM MAY OTHERWISE AGREE TO IN WRITING. | <b>Gamma Vacuum</b><br>12912 Ventura Court, No. 28 * Shakopee, MN<br>TITLE<br>PUMP-ION, 300 L/S, SE, 8"<br>SIZE C DRAWING NO. 300L-XX-8S REV. A<br>SCALE 0.330 DETACHED <input type="checkbox"/> PLO SPEC SHT 2 OF 2 |
|---|---|---|--|

4

3

2

1

4

3

2

DWG. NO. 300L-XX-8D SH. 2 REV. A

THIS DRAWING HAS BEEN GENERATED AND IS MAINTAINED BY PRO/ENGINEER CAD SYSTEM.

D

D

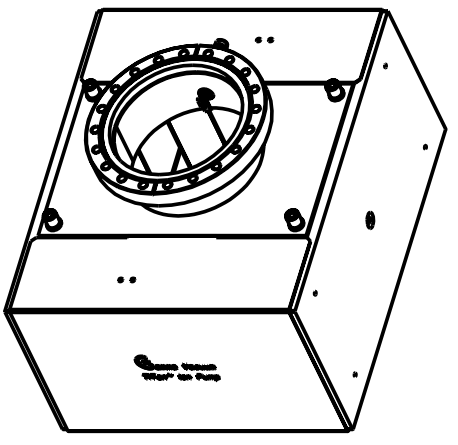
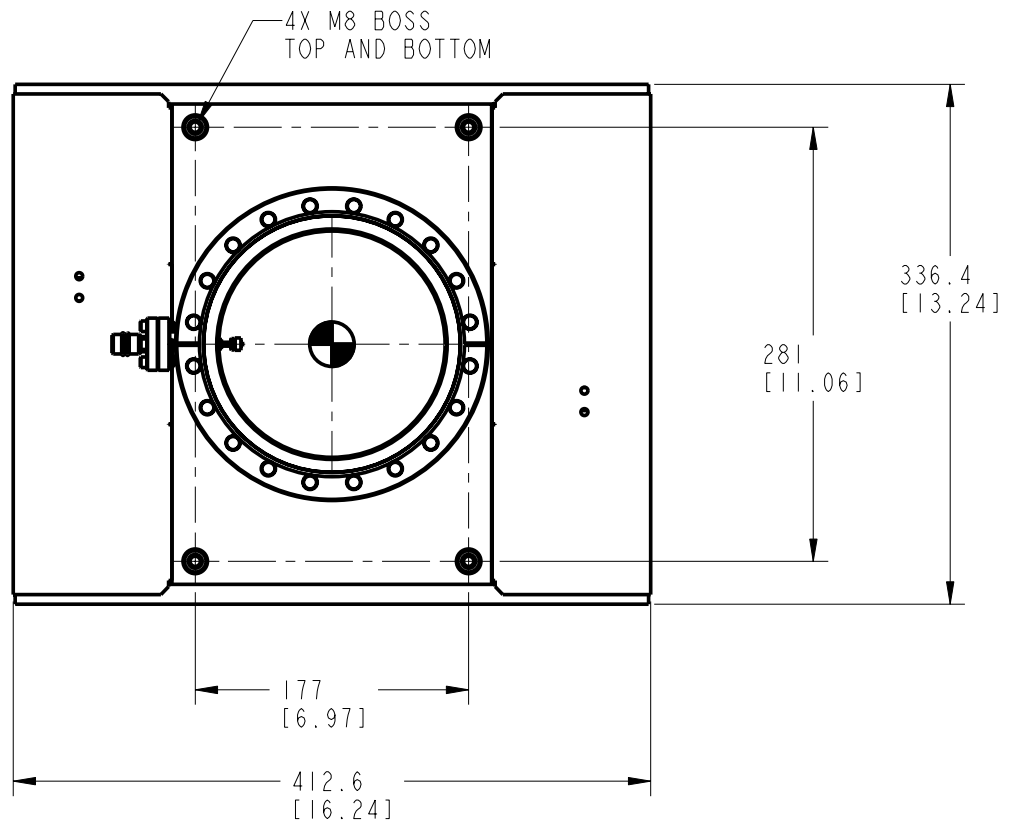

C

C

B

B

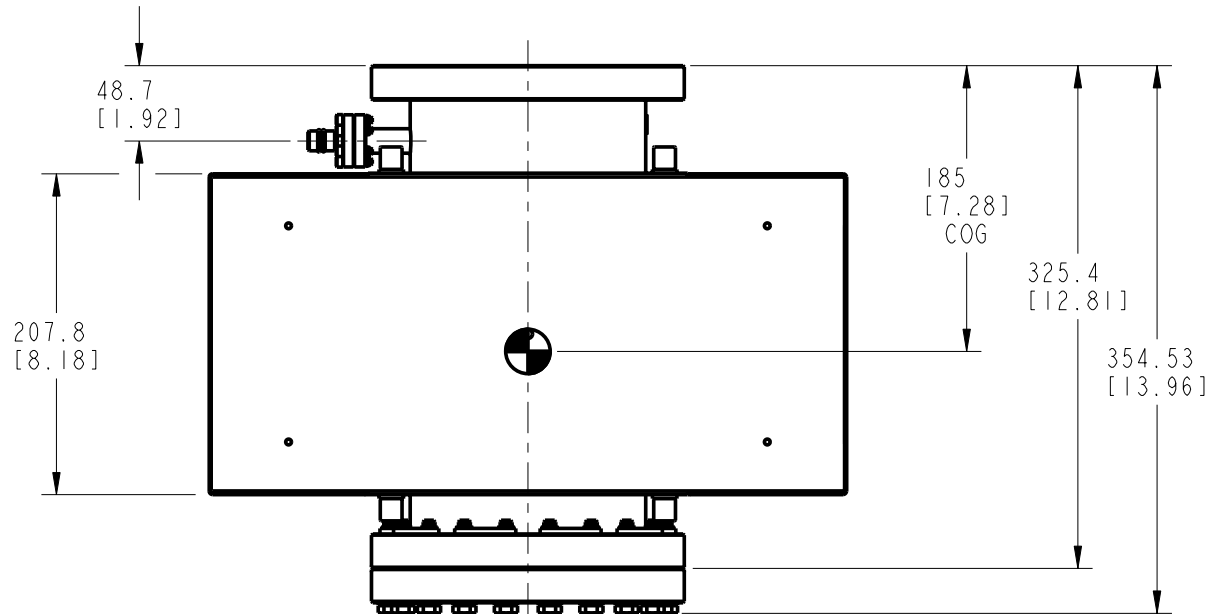

2X 203 CFF  
[8" CFF]  
NON-ROTATABLE

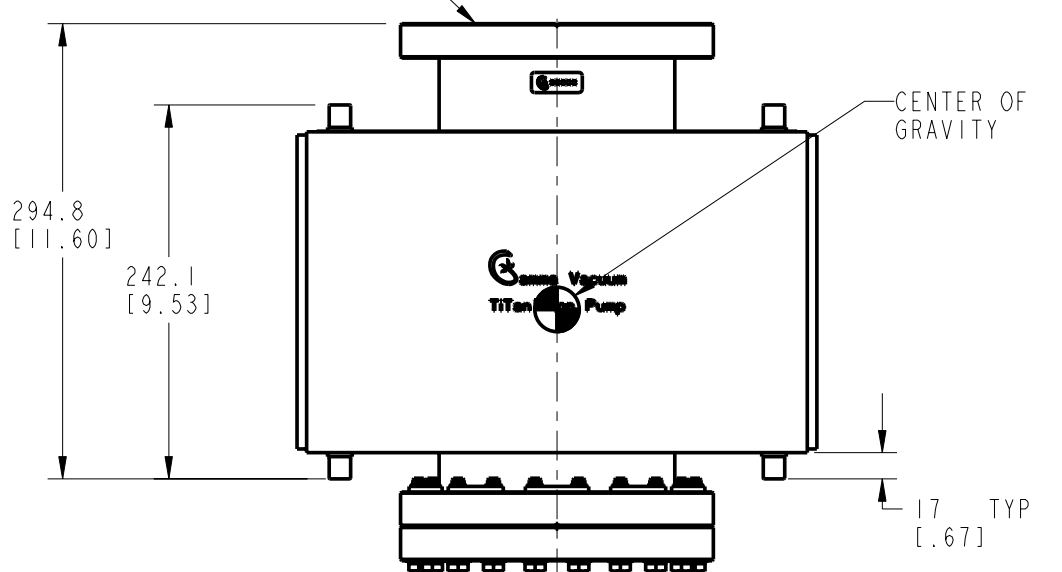

A

A

ALL DIMENSIONS ARE FOR REFERENCE ONLY

|                        |  |   |  |   |
|------------------------|--|---|--|---|
| <b>METRIC</b>          | UNLESS OTHERWISE SPECIFIED<br>DIMENSIONS ARE IN MILLIMETERS<br>SURFACE ROUGHNESS IN MICROMETERS  | DWN R GOLLA   | DATE 17-Nov-97                                       | <b>Gamma Vacuum</b><br>12912 Ventura Court, No. 28 * Shakopee, MN |
|                        | TOLERANCES:<br>LINEAR ±0.13<br>HOLES ±0.13<br>ANGULAR (±)  | CHK   | DATE   |   |
| THIRD ANGLE PROJECTION | MACHINED 0.5°<br>FORMED 1°<br>CHAMFER 5° 1.6   | APPV  | DATE   | TITLE<br>PUMP-ION, 300 L/S, DE, 8"                                |
|                        | MACHINED SURFACES<br>BREAK SHARP EDGES:<br>R0.2 OR 45° 0.2 MAX.<br>INTERNAL MACH CORNER R.4 MAX.   | R1  | TOLERANCING AND DIMENSIONING<br>PER ANSI Y14.5M-1982 | SIZE<br>C   |
|                        | THIS DRAWING CONTAINS PROPRIETARY<br>INFORMATION AND ANY REPRODUCTION,<br>DISCLOSURE OR USE OF THIS DRAWING<br>IS EXPRESSLY PROHIBITED EXCEPT AS<br>GAMMA VACUUM MAY OTHERWISE<br>AGREE TO IN WRITING. | R GOLLA   |  | DRAWING NO. 300L-XX-8D  |
|                        |  | SCALE 0.330 DETACHED <input type="checkbox"/> PLO <input type="checkbox"/> SPEC |  | REV. A  |
|                        |  |   |  | SHT 2 OF 2  |

4

3

2

1